



# NIVOTRACK

M-300, M-300 Ex series  
2-wire compact  
magnetostrictive level transmitter

## INSTALLATION and PROGRAMMING MANUAL

1th Edition



Manufacturer:

**NIVELCO Ipari Elektronika Rt.**

H-1043 Budapest, Dugonics u. 11.

Phone.: -369-7575 ♦ Fax: -369-8585

e-mail:sales@nivelco.com ♦ www.nivelco.com

# BASIC CONCEPT OF MEASUREMENT WITH NIVOTRACK

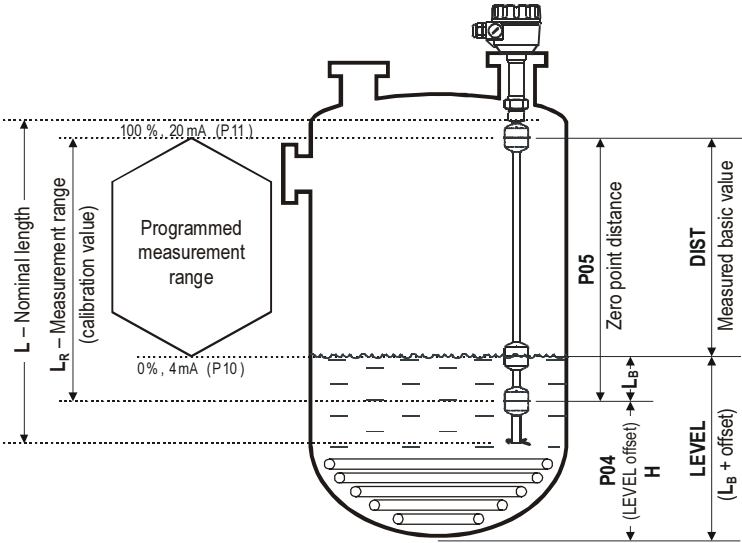

$$L_B = P05 - DIST,$$

$$LEVEL = L_B + P04 = P05 - DIST + P04$$

# CONTENTS

|  |    |
|--|----|
| <b>1. INTRODUCTION</b> .....   | 5  |
| <b>2. ORDER CODE</b> .....   | 6  |
| 2.1 DIMENSIONS .....   | 7  |
| <b>3. TECHNICAL DATA</b> .....                                       | 9  |
| 3.1 ACCESSORIES .....  | 11 |
| 3.2 A CONDITIONS CONDITIONS OF EX APPLICATION .....                  | 11 |
| 3.3 TEMPERATURE CLASSES .....  | 12 |
| 3.4 MAINTENANCE AND REPAIR E .....                                   | 12 |
| <b>4. INSTALLATION</b> .....   | 13 |
| 4.1 MOUNTING .....   | 13 |
| 4.2 WIRING .....   | 14 |
| 4.2.1 <i>wiring of Ex certified units</i> .....                      | 15 |
| 4.3 LOOP CURRENT CHECKING .....                                      | 15 |
| <b>5. PROGRAMMING</b> .....  | 15 |
| 5.1 PROGRAMMING WITHOUT DISPLAY MODULE .....                         | 16 |
| 5.2 PROGRAMMING WITH THE SAP-201 DISPLAY MODULE .....                | 19 |
| 5.2.1 <i>SAP-201 Display Module</i> .....                            | 19 |
| 5.2.2 <i>Steps of programming by the SAP-20 Display Module</i> ..... | 20 |
| 5.2.3 <i>Indications of the SAP-201 and LED Status</i> .....         | 21 |
| 5.2.4 <i>QUICKSET</i> .....  | 22 |
| 5.2.5 <i>Full parameter access</i> .....                             | 24 |
| <b>6. PARAMETERS – DESCRIPTIONS AND PROGRAMMING</b> .....            | 26 |
| 6.1 MEASUREMENT CONFIGURATION .....                                  | 26 |
| 6.2 CURRENT OUTPUT .....   | 30 |
| 6.3 MEASUREMENT OPTIMISATION .....                                   | 31 |
| 6.4 VOLUME MEASUREMENT .....   | 32 |
| 6.5 32-POINT LINEARISATION .....                                     | 33 |
| 6.6 INFORMATIONAL PARAMETERS (READ OUT PARAMETERS) .....             | 34 |
| 6.7 SERVICE PARAMETERS .....   | 35 |
| 6.8 SIMULATION .....   | 35 |
| 6.9 ACCESS LOCK .....  | 36 |
| <b>7. ERROR CODES</b> .....  | 37 |
| <b>8. PARAMETER TABLE</b> .....                                      | 38 |



*Thank you for choosing NIVELCO.  
We are sure that you will be satisfied throughout its use!*

## 1. INTRODUCTION

### Application

NIVOTRACK M-30 series working on the magnetostrictive principle are suitable for high accuracy level measurement of storage tanks. Due to their high temperature and pressure rating these units can also be used for level gauging of technological tanks. The most suitable applications are with liquids free of solid particles and with low viscosity both in ordinary and hazardous locations.

Its high precision renders NIVOTRACK suitable for custody transfer measurement of valuable liquids such as fuels, solvents, alcohol distillates, etc. Plastic version of the series substantially expands the field of application by a wide range of aggressive materials.

### Operating principle

The magnetostrictive transmitter is using the special feature of the magnetostrictive wire spanned in the rigid or flexible probe. An electric excitation signal given to the magnetostrictive wire develops a twist in the wire at the interference point with the magnetic disc placed in the float. The twist travels back to the electronics in the form of an acoustic wave with defined velocity. Measurement is based on measuring the flying time since it is proportional with the distance of the float from the electronics.

The above distance constitutes the basis for all output signals of the NIVOTRACK!

With the help of further mechanical data level and volume (tank content) can be calculated.

# 2. ORDER CODE

NIVOTRACK M   -   -

| TYPE                                 | CODE |
|--------------------------------------|------|
| Transmitter                          | T    |
| Transmitter+display                  | B    |
| Transmitter PFA coated probe         | E    |
| Transmitter+display PFA coated probe | G    |

| PROBE / PROCESS CONNECTION | CODE |
|----------------------------|------|
| Tube 1" BSP                | A    |
| Tube 2" BSP                | C    |
| Tube 1" NPT                | D    |
| Tube 2" NPT                | G    |
| W/O process conn.*         | U*   |
| Flexible 2" BSP            | K    |
| Flexible 2" NPT            | N    |

| HOUSING   | CODE |
|-----------|------|
| Aluminium | 3    |
| Plastic   | 4    |

| CODE | NOMINAL LENGTH | CODE |
|------|----------------|------|
| 0    | 0 m            | 0    |
| 1    | 1 m            | 1    |
| 2    | 2 m            | 2    |
| 3    | 3 m            | 3    |
| 4    | 4 m            | 4    |
| 5    | 5 m            | 5    |
| 6    | 6 m            | 6    |
| 7    | 7 m            | 7    |
| 8    | 8 m            | 8    |
| 9    | 9 m            | 9    |
| A    | 10 m           |      |

| OUTPUT / NUMBER OF FLOATS / EX                 | CODE |
|--|------|
| 4 ... 20 mA / 1x float                         | 2    |
| 4 ... 20 mA, HART / 1x float                   | 4    |
| 4 ... 20 mA / 1x float / EEx ia                | 6    |
| 4 ... 20 mA, HART / 1x float / EEx ia          | 8    |
| 4 ... 20 mA / 1x float / EEx d                 | A    |
| 4 ... 20 mA, HART / 1x float / EEx d           | B    |
| 4 ... 20 mA / 1x float / EEx d + EEx ia        | C    |
| 4 ... 20 mA, HART / 1x float / EEx d + EEx ia  | D    |
| 4 ... 20 mA, HART / 1x float / 5 mm resolution | N    |

\* Process connection to be ordered separately

## ACCESSORIE TO BE ORDERE:

FLANGES M F T -   -

| STANDARDS/MATERIAL        | CODE |
|---------------------------|------|
| DIN / carbon steel        | 1    |
| DIN / 1.4571              | 2    |
| DIN / PP                  | 3    |
| DIN / carbon steel + PTFE | 4    |
| ANSI / carbon steel       | 5    |
| ANSI / 1.4571             | 6    |
| ANSI / PP                 | 7    |
| ANSI / A38 + PTFE         | 8    |

| DIMENSION | CODE |
|-----------|------|
| DIN ANSI  |      |
| DN 65 2½" | 1    |
| DN 80 3"  | 2    |
| DN 100 4" | 3    |
| DN 125 5" | 4    |
| DN 150 6" | 5    |
| DN 200 8" | 6    |

| PRESSURE        | CODE |
|-----------------|------|
| PN 16 / 150 psi | 1    |
| PN 25 / 300 psi | 2    |

| INNER DESIGN | CODE |
|--------------|------|
| Gland        | 1    |
| 1" BSP       | 2    |
| 2" BSP       | 3    |
| 1" NPT       | 5    |
| 2" NPT       | 6    |

## SLIDING SLEEVES:

| TYPE              | CON-NECTION | S (mm) | H (mm) | L (mm) | B (mm) |
|-------------------|-------------|--------|--------|--------|--------|
| MBH-105-2M-300-00 | 1" BSP      | 41     | 36     | 20     |        |
| MBK-105-2M-300-00 | 2" BSP      | 70     | 43     | 24     |        |
| MBL-105-2M-300-00 | 1" NPT      | 41     | 38     |        | ~10    |
| MBN-105-2M-300-00 | 2" NPT      | 70     | 43     |        | ~11    |

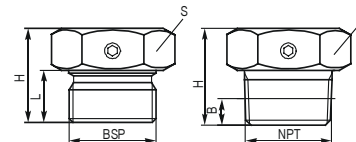

## 2.1 DIMENSIONS

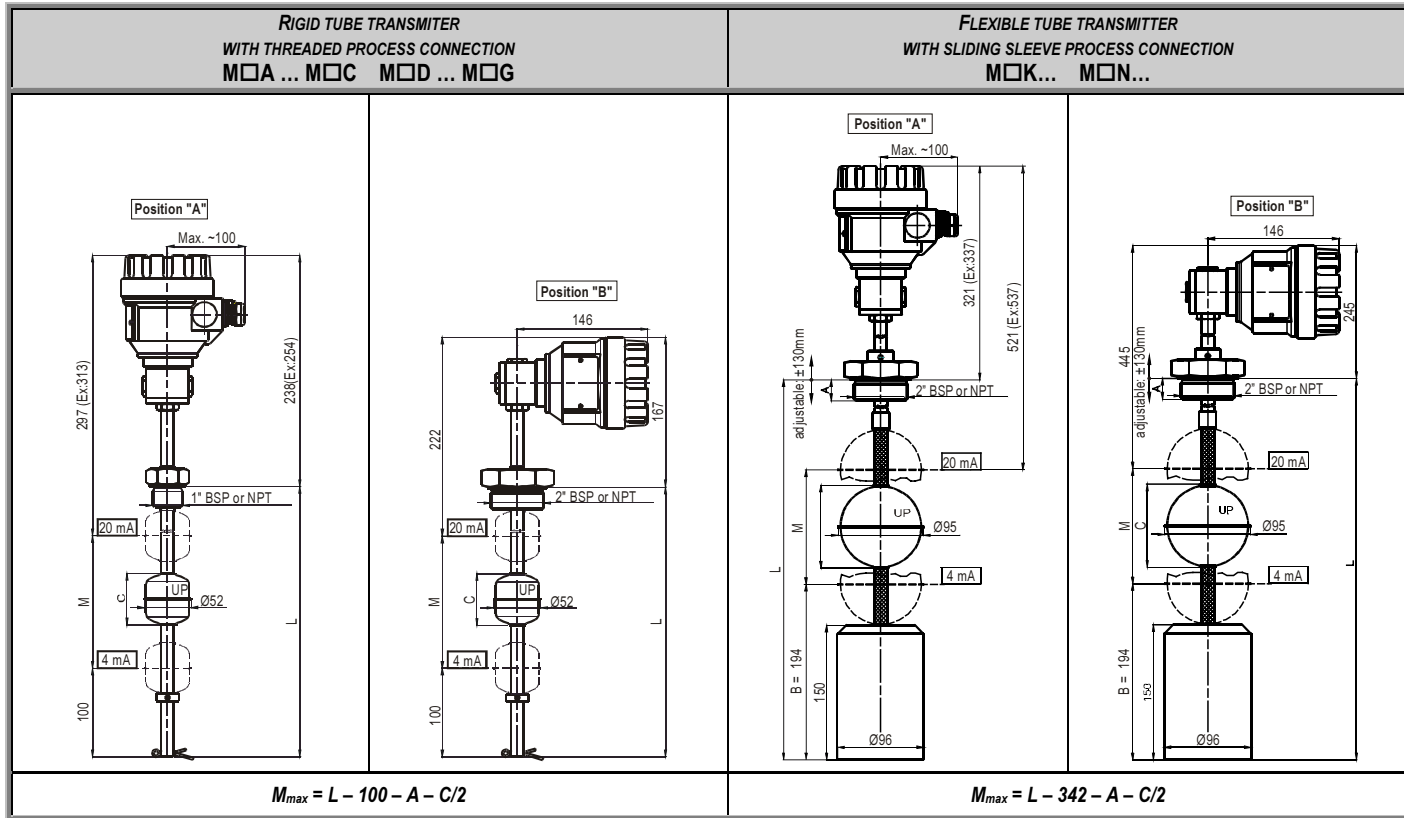

L = Nominal length

M = Measurement range

B = Bottom dead band

C = Ball height

A + C/2 = Top dead band \*See ball dimensions in the Technical Data

**RIGID TUBE TRANSMITTER  
WITHOUT PROCESS CONNECTION  
MTU... MBU...**

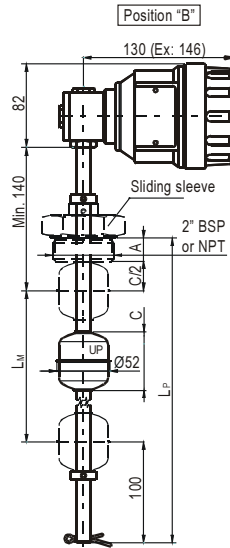
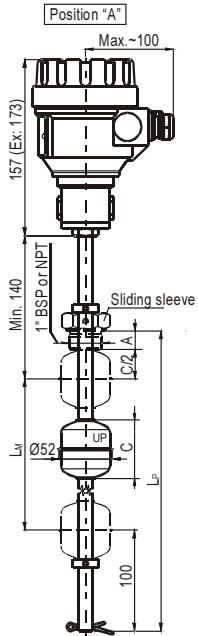

$$L_{Max} = L_p - 100 - A - C/2$$

**FLEXIBLE TUBE TRANSMITTER  
WITHOUT PROCESS CONNECTION  
MEU... MGU...**

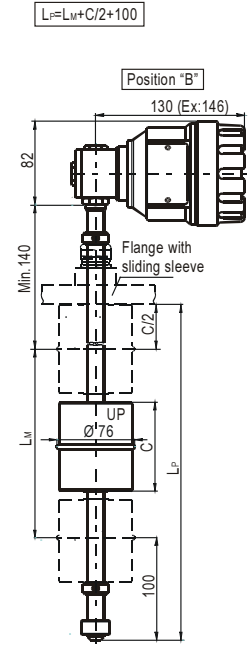
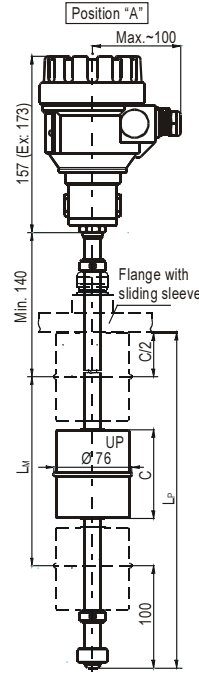

$$L_{Max} = L_p - 100 - C/2$$

$L_{Max}$  = Nominal length



### 3. TECHNICAL DATA

| TYPE                                  | RIGID TUBE VERSION<br>M□A..., M□C..., M□D...,<br>M□G..., MTU..., MBU...   | FLEXIBLE TUBE VERSION<br>M□K...<br>M□N...             | RIGID PLASTIC VERSION<br>MEU...<br>MGU... |
|---------------------------------------|---|---|---|
| Measured process values               | Level; two float version: interface level, level difference   |   |   |
| Nominal length (L)                    | 0.5 m ... 4.5 m   | 2 m ... 10 m  | 0.5 m ... 3 m                             |
| Material of the tube                  | Stainless steel: 1.4571 (DIN)   |   | PFA coated st.st.                         |
| Max. medium pressure                  | 2.5 MPa (25 bar)  | 1.6 MPa (16 bar)                                      | 0.3 MPa (3 bar)                           |
| Medium temperature                    | -40 °C ... +130 °C see temperature chart  |   |   |
| Linearity with dry calibration        | ±1 mm   |   |   |
| Resolution                            | 1mm or 5 mm (depending on order)  |   |   |
| Temperature coefficient               | 0.04 mm/°C  |   |   |
| Range (M)                             | Maximum: see calculating formula under DIMENSIONS   |   | Minimum: 200 mm                           |
| Zero span                             | Anywhere within the range   |   |   |
| Float diameter / material             | ∅ 52 x 59 mm / st.st. or ∅ 95 mm / st.st.*  |   | ∅ 76 x 87 mm / PVDF                       |
| Medium density                        | min. 0.8 g/cm <sup>3</sup> ; with ball float ∅ 95 mm: min. 0.5 g/cm <sup>3</sup>  |   |   |
| Material of wetted parts              | Stainless steel: 1.4571 (DIN)   |   | PFA and PVDF                              |
| Ambient temperature *                 | -40 °C ... +70 °C (see temperature chart)   |   |   |
| Outputs<br>(for any process<br>value) | Analogue  | 4...20 mA (can also be assigned in inverted mode)     |   |
|                                       | Serial comm.  | HART interface (close end resistor 250 Ohm)           |   |
|                                       | Display   | with SAP-201 6 digits (7 mm character) icon, bargraph |   |
| Damping                               | 0 ... 60 s programmable   |   |   |
| Error indication                      | By the current output: 3.8 mA or 22 mA  |   |   |
| Output load                           | Rs = (Us - 12V) / 0.02 A, Us = voltage of the power supply  |   |   |
| Power supply                          | 12 ... 36 V DC  |   |   |
| Intrinsic safety data                 | U <sub>max</sub> = 30 V I <sub>max</sub> = 140 mA P <sub>max</sub> = 1 W C <sub>i</sub> < 15 nF L <sub>i</sub> < 200 μH |   |   |
| Electric protection                   | Class III.  |   |   |
| Ingress protection                    | IP 67   |   |   |
| Process connection                    | According to the order codes  |   |   |
| Electric connection                   | Outer diameter of the cable for M 20 x1.5 conduit: ∅ 6 ... ∅ 12 mm Wire cross section: max. 1.5 mm <sup>2</sup>         |   |   |
| Housing                               | Aluminium (powder paint coated) or plastic (PBT fibre-glass reinforced, flame retardant)                                |   |   |
| Mass                                  | 1.7 kg + tube: 0.6 kg/m   | 1.7 kg + tube: 0.6 kg/m + 12 kg                       | 1.7 kg + tube: 0.6 kg/m                   |

\* Maximum medium pressure for units with float ∅ 95 mm: 1,6 MPa (16 bar)

| Type                  | M □□-3 □□-6Ex<br>M □□-3 □□-8Ex<br>M □□-3 □□-GEx<br>M □□-3 □□-HEx   | M □□-3 □□-AEx<br>M □□-3 □□-BEx<br>M □□-3 □□-JEx<br>M □□-3 □□-KEx | M □□-3 □□-CEx<br>M □□-3 □□-DEx<br>M □□-3 □□-LEx<br>M □□-3 □□-MEx |
|-----------------------|--|--|--|
| Ex marking            | ⊕ II 1 G EEEx i <sub>a</sub> IIB T6...T4<br>0,5...5m   | ⊕ II 2 G EEEx d IIB T6...T4                                      | ⊕ II 1/2 G EEEx d i <sub>a</sub> IIB T6...T4<br>0,5...5m         |
|                       | ⊕ II 1 G EEEx i <sub>a</sub> IIA T6...T4<br>5...10m  |  | ⊕ II 1/2 G EEEx d i <sub>a</sub> IIA T6...T4<br>5...10m          |
| Ex electrical data    | U <sub>max</sub> = 30 V   I <sub>max</sub> = 140 mA   P <sub>max</sub> = 1 W<br>C <sub>i</sub> < 15 nF   L <sub>i</sub> < 200 μH |  |  |
| Electrical protection | Class III  |  |  |
| Ingress protection    | IP 67  |  |  |
| Process connection    | According to the order code  |  |  |
| Cable conduit         | M 20 x1,5 conduit  |  |  |
| Cable diameter        | Ø 7 ...13 mm   | Ø 9 ...11 mm   |  |
| Electric connection   | Wire cross section: 0,5...1,5 mm <sup>2</sup>  |  |  |
| Housing               | Paint coated aluminium (öAISI10Mg)   |  |  |

\* Max. medium pressure 1,6 MPa (16 bar)

Maximum allowed ambient temperature over medium temperature of +70 °C

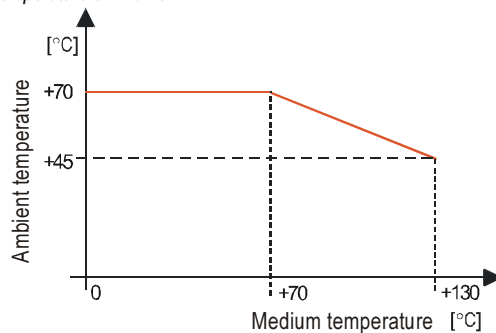

### 3.1 ACCESSORIES

- |  |  |
|--|--|
| <ul style="list-style-type: none"><li>• User's manual,</li><li>• Warranty certificate,</li><li>• Certificate, of conformity</li><li>• Installation and programming manual</li><li>• 2 pcs conduit</li><li>• 1 pc gasket (klingerit oilit) for BSP threads only</li></ul> | <p>Csak az M□K és M□N típushoz</p> <ul style="list-style-type: none"><li>• 1 pc weight</li><li>• 1 pc M 10 nut</li><li>• 1 pc M 10 spring washer</li><li>• 1 pc M 10 washer</li><li>• 1 pc spacer (for float Ø 52 mm only)</li></ul> |
|--|--|

### 3.2 CONDITIONS OF EX APPLICATION

The unit can only be powered by a duly approved and certified EEx ia IIA vagy EEx ia IIB intrinsically safe loop according to the technical data. Device can be mounted to tanks with max working pressure of 3 bar. It is not eligible for flame barrier between the in- and outside space of the tank. After its installation and during its service required pressure tests should be performed in accordance with the relevant regulation. Aluminium hosing of the unit should be connected to the equipotential (grounding) system.

MEU and MGU plastic covered equipment may be electrostatically charged, therefore:

- Medium to measure must be electrically conductive and with specific resistance not exceeding the value of  $10^4 \Omega\text{m}$  even on the most unfavourable places and under the most unfavourable conditions.
- Sped as well as way of filling and emptying should be chosen according to the medium.

### 3.3 TEMPERATURE CLASSES

#### UPPER TEMPERATURE LIMITS

| TYPE                                     | TEMPERATURE CLASS | AMBIENT TEMPERATURE MAX | MEDIUM-TEMPERATURE MAX |
|--|-------------------|-------------------------|------------------------|
| M□A -..., M□C -<br>M□D -..., M□G -...    | T6                | +70 °C                  | +80 °C                 |
| M□K -..., M□N -...                       |                   |                         | +70 °C                 |
| MEU -..., MGU -...                       |                   |                         | +80 °C                 |
| M□A -..., M□C -...<br>M□D -..., M□G -... | T5                | +59 °C                  | +95 °C                 |
| MEU -..., MGU -...                       |                   |                         | +95 °C                 |
| M□A -..., M□C -...<br>M□D -..., M□G -... |                   |                         | T4                     |
| MEU -..., MGU -...                       | +130 °C           |                         |                        |

#### LOWER TEMPERATURE LIMITS

| TYPE               | EX MARKING |         |         |
|--------------------|------------|---------|---------|
|                    | ia         | d       | d+ia    |
| MT□ -..., ME□ -... | - 40 °C    | - 40 °C | - 40 °C |
| MB□ -..., MG□ -... | - 25 °C    | - 20 °C | - 20 °C |

### 3.4 MAINTENANCE AND REPAIR

The unit does not require routine maintenance, however the probe may need occasional cleaning to remove surface deposits. Repairs will be performed at Manufacturer's premises. Units returned for repair should be cleaned or disinfected by the customer.

## 4. INSTALLATION

### 4.1 MOUNTING

- The unit should be located in an area, which allows easy access for service, calibration and monitoring.
- Waving, turbulence and heavy vibration affects accuracy of the measurement. Thus the unit has to be installed far away from devices or places causing such disturbance for instance from openings for filling or emptying. These affects can be attenuated in applications with rigid tube probes by the use of stilling pipe along the whole probe. Kindly consult Nivelco distributor!
- To ensure consistent and durable operation the process fluid should be free of suspended solids or materials, which could stick between the float and the guide tube.
- **The unit should be protected against direct heat radiation.**
- Design dimensions of the unit and the tank as well as calculations should be checked before mounting.
- Before installation a preliminary operational check is suggested.
- Should manufacturer setting be changed it is to perform as per chapter 5.
- The unit is offered with a wide variety of process connections according to the order codes Tank opening exceeding the float diameter is recommended for insertion. Should this not be possible the float has to be removed from the (rigid or flexible) guide inserted through the opening and the float must be reattached from inside of the vessel. The word "UP" etched on the float is to ensure mounting the float in correct position.
- Insertion position of the MEU and MGU types can be adjusted. Free length over the tank however must not be longer than 200 mm.
- **Units with flexible tube of type M□K ... M□N are provided with weight for spanning of the tube and keeping it in position. Weight and fastening nut are part of the unit. When lowering down the flexible tube (with the weight at his end) to the bottom of the tank, special care has to be taken to avoid interlocking or twisting and the coil diameter must not be smaller than 60 cm. Dropping or twitching may damage the unit. Float or floats should be placed next to the weight to avoid its hitting against the weight. Proper spanning can be checked by the analogue signal or on the display. If the float is at the lowest point  $I_{out} < 4 \text{ mA}$  or display should read  $< 0 \text{ mm}$**

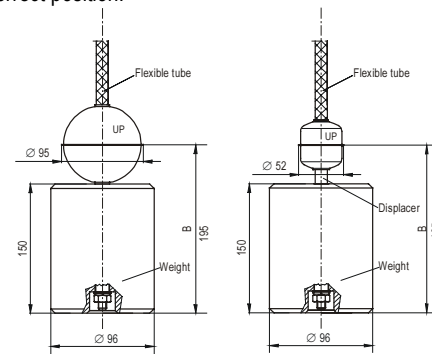

### Attention!

In order to avoid damaging the probe do not put it to torsion when installing or removing the unit. Therefore, special care has to be taken when the process connection is being screwed into or out of the flange. The best is to hold the rigid part of the probe with a suitable tool as long as the process connection is tightened to its place. Sliding sleeve must not be loosened during operation.

## 4.2 WIRING

This transmitter is designed to operate on 12 ... 36 V DC power only. The maximum loop resistance (including barrier resistance) is depending on the voltage of the power supply and can be between 0 and 1200 Ohm. Calculation formula can be seen in the Technical Table under Output Load. Using transmitter with HART a terminal resistance with a minimum value of 250 Ohm should be applied.

The power supply should be interconnected with the unit with twisted, shielded cable that can be pulled through the cable conduit. The cable can be connected to the terminal strip after removing the cover and the display unit.

**CAUTION:** the enclosure of the transmitter should be grounded. Grounding resistance should be < 1 Ohm. Shielding of the interconnecting cable should be grounded at the end of the control room. To avoid disturbing noises the interconnecting cable must not be led near to high voltage cables. Especially critical are inductive couplings of AC harmonics against which the protection of shielding is not effective.

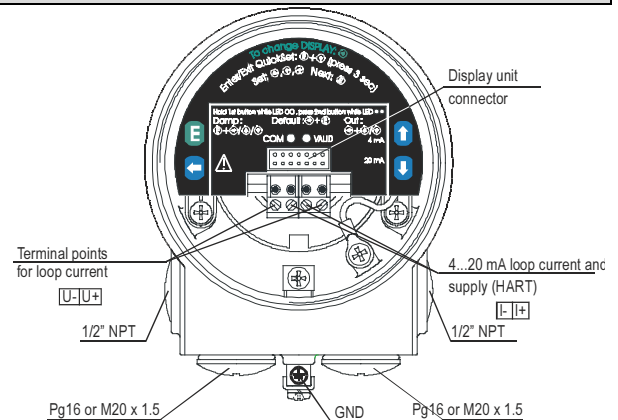

The unit may be damaged by electrostatic discharge (EDS), via its terminal thus used commonly precautions should be applied to avoid electrostatic discharge e.g. touching a properly grounded point before removing the cover of the enclosure.

Possible electrostatic discharge may damage the unit. Does the internal electric connection points must not be touched by hand.

## 4.2.1 WIRING OF EX CERTIFIED UNITS

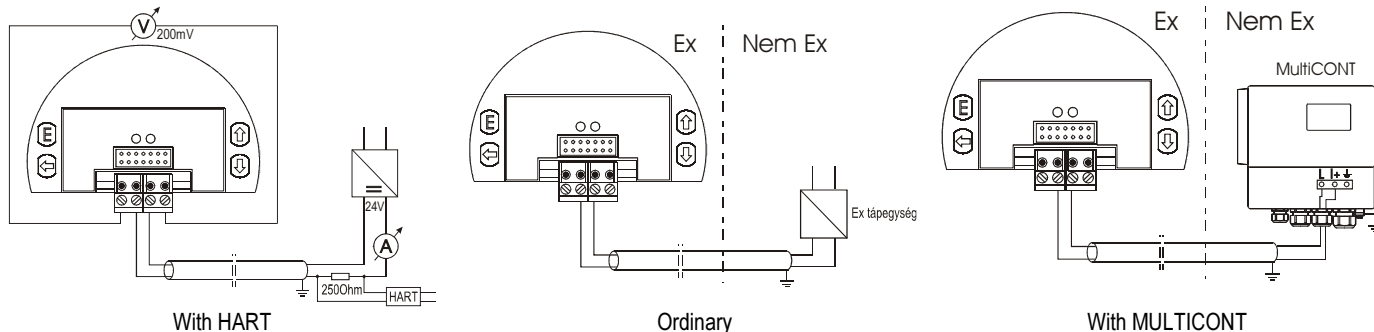

## 4.3 LOOP CURRENT CHECKING

After removing the cover and the display module the actual loop current can be measured with an accuracy of 0,5 % by connecting a voltmeter (in the range of 200 mV) to the points indicated on the drawing above

## 5. PROGRAMMING

The NIVOTRACK can be programmed by the following two ways:

- **Programming without Display Module** see 5.1.  
Assignment of the levels to the 4 and 20 mA current output, error indication by the analogue signal and damping can be set.
- **With the SAP-201 Display Module**, see 5.2.  
All features of the unit can be set, such as measurement configuration, zero offset, , output assignments, measurement optimisation 32-point linearisation, dimensions  
for 11 tanks with different shape.

Devices with the type number **NIVOTRACK MB□-3□□** and **MG□-3□□** are already equipped with the SAP-201.

The NIVOTRACK is fully operational without the SAP-201. The SAP-201 is only needed for programming and/or displaying measurement values.

The unit will measure during programming in accordance with the previous parameters. The new, modified parameters will only be effective after returning to the Measurement Mode

If the transmitter is left in Programming Mode by mistake, it will automatically return to Measurement Mode after 30 minutes and will operate with the parameters entered during the last completed programming.

### FACTORY SETTING (Default)

The NIVOTRACK will be delivered with the following **Factory Default**:

- ⇒ Current output, display and bargraph: LEVEL
- ⇒ Current output and bargraph proportional to the level
- ⇒ 4 mA: assigned to the minimum level 0%
- ⇒ 20 mA: assigned to the maximum level 100%
- ⇒ Error indication by the current output: hold last value
- ⇒ Damping: 60 sec

## 5.1 PROGRAMMING WITHOUT DISPLAY MODULE

Programming is only possible if the NIVOTRACK is in Level Measuring Mode and the “VALID” LED is lit (representing stable medium surface)

The following can be programmed without display module

- Assignment of the 4 mA to the required minimum level
- Assignment of the 20 mA to the required maximum level
- Error indication by the current output (Hold, 3.8 mA or 22 mA)
- Damping (10, 30 or 60 sec)
- Reset to the factory default

*Note: Current output can also be assigned in inverted mode:  
4 mA = 100% (Full), 20 mA = 0% (Empty)*

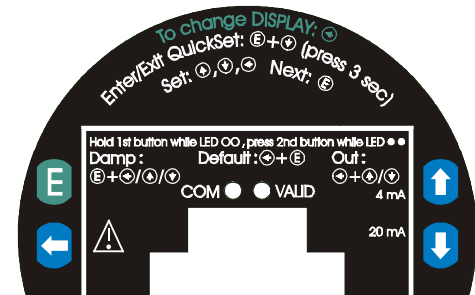

**Procedure of programming:** press button in the relevant sequence and check the state of the LED-s. Symbols for the states of the LED-s:

○ = LED is off, ● (with a dot) = LED is blinking, ● (solid) = LED is on, ● (with a dot) ● (with a dot) = LEDs are blinking alternatively, ⊗ = Don't care



### Assignment of low (0%, minimum) level to 4 mA

| Action                        | LED state following the action                |  |
|-------------------------------|---|--|
| 1) Check for a stable surface | ⊗● = Stable surface, transmitter programmable | Tank should be filled up to the level which is to be assigned to the current output of 4 mA. |
| 2) Press NEXT ◀ keys steadily | ○○ = NIVOTRACK in programming mode            |  |
| 3) Press UP ▲ key steadily    | ●● = Level assigned to 4 mA (see picture)     |  |
| 4) Release keys               | ○○ = Programming completed                    |  |

### A felső szint (tele tartály, 100%) hozzárendelése a 20 mA-hez

| Action                        | LED state following the action                |  |
|-------------------------------|---|--|
| 1) Check for a stable surface | ⊗● = Stable surface, transmitter programmable | Tank should be filled up to the level which is to be assigned to the current output of 4 mA. |
| 2) Press NEXT ▶ key steadily  | ○○ = NIVOTRACK in programming mode            |  |
| 3) Press UP ▲ keys steadily   | ●● = Level assigned to 20 mA (see picture)    |  |
| 4) Release keys               | ○○ = Programming completed                    |  |

### “Error state” indication by the analogue signal (Check for a stable surface as above)

As a result of this setting the value of the analogue output will be 3.8 mA; 22 mA or according last value (hold) until the error is ceased.

| Action  | LED state following the action                              |
|---|---|
| 1) Press $\uparrow$ key steadily  | $\circ\circ$ = NIVOTRACK in programming mode                |
| 2) Press and keep DOWN $\downarrow$ ,<br>so any of the keys ENTER $\text{E}$ ,<br>NEXT $\leftarrow$ | $\bullet\bullet$ = – hold last value<br>– 3.8 mA<br>– 22 mA |
| 3) Release keys   | $\circ\circ$ = Programming completed                        |

#### Damping time setting (Check for a stable surface as above)

| Action   | LED state following the action                      |
|--|---|
| 1) Press ENTER $\text{E}$ key steadily   | $\circ\circ$ = NIVOTRACK in programming mode        |
| 2) Press and keep NEXT $\leftarrow$ ,<br>so any of the keys UP $\uparrow$ ,<br>DOWN $\downarrow$ | $\bullet\bullet$ = – 10 sec<br>– 30 sec<br>– 60 sec |
| 3) Release keys  | $\circ\circ$ = Programming completed                |

#### RESET: Returning to the default (Check for a stable surface as above)

| Action                                  | LED state following the action               |
|---|--|
| 1) Press NEXT $\leftarrow$ key steadily | $\circ\circ$ = NIVOTRACK in programming mode |
| 2) Press ENTER $\text{E}$ key steadily  | $\bullet\bullet$ = Default loaded            |

#### Indication of mistakes (by LEDs) made during programming

| Action                | LED state following the action  | Possible correction             |
|-----------------------|---|---------------------------------|
| Attempted programming | $\bullet\circ$ = blinking twice = probe failure   | Call service                    |
| Attempted programming | $\bullet\bullet\circ$ = blinking three times = no access possible                       | With SAP-201 only See 5.2 (P99) |
| Attempted programming | $\bullet\bullet\bullet$ = blinking four times = NIVOTRACK not in Level Measurement Mode | With SAP-201 only See 5.2 (P01) |

## 5.2 PROGRAMMING WITH THE SAP-201 DISPLAY MODULE

The NIVOTRACK should be adjusted to the process by programming the parameters. The SAP-201 Display Module can be used to display the parameters during programming and measurement values during measurement..

### Gyorsprogramozás (QUICKSET) (5.2.4)

Recommended for fast programming of the following 6 basic parameters

- Selection of the engineering units for the display (Metric or US)
- Zero offset
- Assignment of the analogue output
- Error indication by the current output
- Damping time

### Full Parameter Access (5.2.5)

Highest level of programming for access of all features of the NIVOTRACK such as:

- Settings as with the QUICKSET
- Measurement configuration
- Measurement optimisation
- 11 pre-programmed tank shapes for volume calculation
- 32-point linearisation

### 5.2.1 SAP-201 Display Module

Symbols used on the LCD:

- **DIST** – Distance (measuring) mode
- **LEV** – Level (measuring) mode
- **VOL** – Volume (measuring) mode
- **PROG** - Programming mode (device under programming)
- **FAIL** - Measurement / device error
- **↑ ↓** - Level changing direction
- Bargraph proportional to the current output

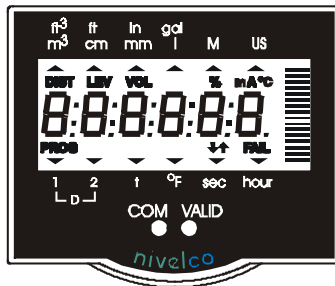

Symbols used on the frame

- **M** – metric (European) system
- **US** – imperial unit system
- **1** – Upper float
- **2** – Lower float
- **Δ** - Difference

Status indication LEDs

- **COM** – indicating HART communication
- **VALID** – indicating stable surface.

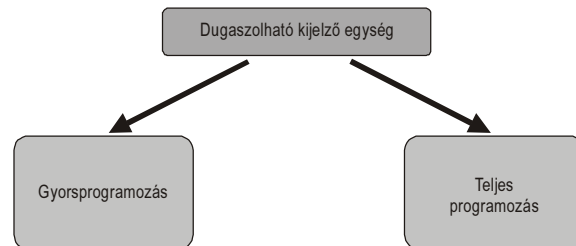

## 5.2.2 Steps of programming by the SAP-20 Display Module

Programming will be performed by pressing and releasing the relevant one or two keys (simultaneously). Programming steps below are for the overview only, detailed description is under 5.2.4 and 5.2.5.

### Single key pressing

- ENTER (E) to select parameter address and go to parameter value  
to save parameter value and return to parameter address
- NEXT (←) to move the blinking (sign of change) of the digit to the left
- UP (↑) to increase value of the blinking digit
- DOWN (↓) to decrease value of the blinking digit

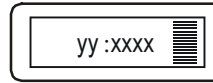

yy parameter address (P01, P02...P99)  
xxxx parameter value (dcba)  
Bargraph

### Double key pressing

Press two keys simultaneously for desired programming step. Simultaneous pressing will be indicated by " + ".

#### Enter into or quit programming modes

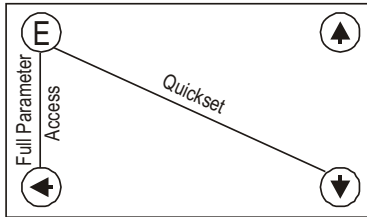

#### Basic steps while parameter address is blinking

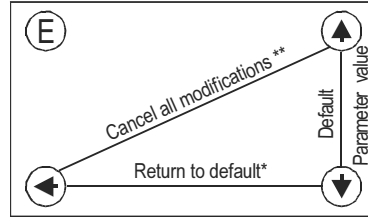

\* LOAD readout \*\* CANCEL readout

#### Basic steps while parameter value is blinking

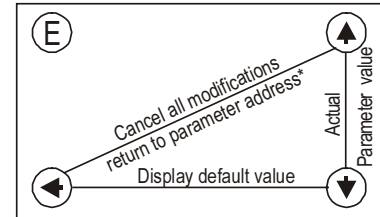

\* cancellation immediately active

### GET LEVEL function

Special function used only in level and distance measurement modes UP (↑) + DOWN (↓)

Notes:

If after pressing ENTER (E) blinking does not spring over from the parameter address to the parameter value this means that

- the parameter is either a read-out type, or
- the secret code prevents the modification (see P99)

If the modification of the parameter value is not accepted i.e. the parameter value keeps blinking after pressing ENTER (E),

- the modified value is either out of the range, or
- the code entered is not a valid code

### 5.2.3 Indications of the SAP-201 and LED Status

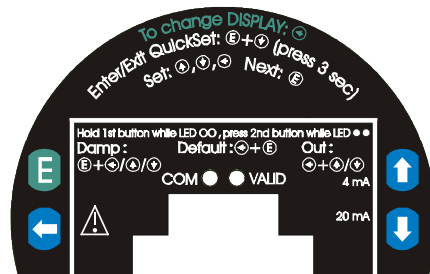
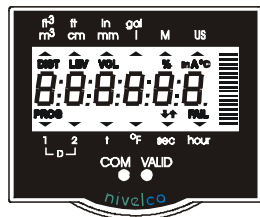

#### LED indication

- **VALID-LED**  
lit in case of stable surface  
blinking with unstable surface
- **COM-LED**  
Indicating HART communication

#### SAP-201 indications

Depending on the measurement one of the below symbols will lit and the process value displayed (see P01 chapter 6.1). Engineering units will be indicated directly (°C, °F and mA) and by the lit arrow showing towards them on the frame

- DIST distance
- LEV level
- VOL volume
- FAIL (blinking) Error code displayed

For paging readouts NEXT (E) key should be pressed.

#### Process values displayed

A kijelzőn a következő mennyiségek jeleníthetők meg:

- Volume – if programmed so
- Level – if programmed so
- Distance – if programmed so
- Warning indications – FAIL blinking

Display screens can be scrolled by pressing key NEXT (E). To return to the screen of the selected measurement mode key ENTER (E) should be pressed (see P01 chapter 6.1)

Current output value can be displayed by pressing key (+).

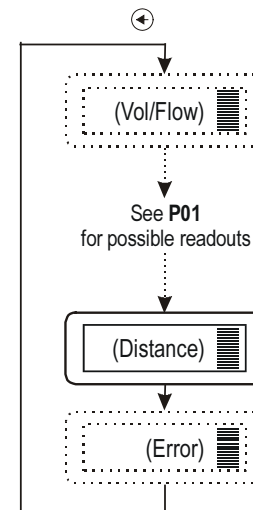
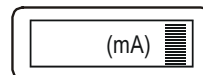

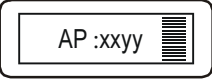
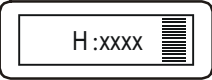
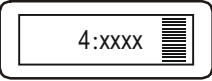

| Screens   | Actions   |
|---|---|
|  <p>AP :xxyy</p> | <p><b>Application</b><br/> <b>xx</b>= select "EU" (European) for metric or "US" for US engineering units (Use UP ▲ /DOWN ▼ keys)<br/> <b>yy</b>= indicating "Li" for liquids<br/>           DEFAULT: EU</p> <div style="border: 1px solid black; padding: 5px; text-align: center;"> <p><b>Warning: Changing of this parameter will result in loading the full parameter set with the values of the factory default with the corresponding engineering units. Thus reprogramming may be necessary!</b></p> </div> |
|  <p>H :xxxx</p>  | <p><b>H = xxxx Zeropoint offset</b> – Distance between lower end position of the float and the tank bottom.<br/>           Manual: set value (Use UP ▲ /DOWN ▼ /NEXT ◀ keys) and save it (by ENTER Ⓔ)</p> <p>DEFAULT: 0</p>   |
|  <p>4 :xxxx</p>  | <p><b>4 mA xxxx – level value</b> assigned to 4 mA current output</p> <p>Manual: set level value (by UP ▲ /DOWN ▼ /NEXT ◀ keys) and save it (by ENTER Ⓔ)<br/>           Automatic: use the "GET LEVEL" function (UP ▲ + DOWN ▼) to display the actual measured value with level in tank or a fixed target, i.e. wall. ("GET LEVEL" functions only if VALID LED is lit) and save it as above.</p> <p>DEFAULT: 0 m (0%, minimum level)</p>  |

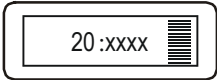
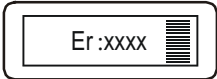
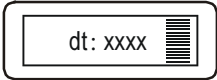
| Screens   | Actions   |
|---|---|
|  | <p><b>20 mA xxxx – level value</b> assigned to 20 mA current output</p> <p>Manual: set level value (Use UP ▲ / DOWN ▼ / NEXT ◀ keys) and save it (by ENTER ⊞)</p> <p>Automatic: use the “GET LEVEL” function (UP ▲ + DOWN ▼) to obtain actual measured value with level in tank or a fixed target, i.e. wall. (“GET LEVEL” functions only if ECHO LED is lit) and save it as above.</p> <p>DEFAULT: maximum measuring range [m]</p> |
|  | <p><b>Error indication</b> by the current output – select “Hold”, 3.6 mA or 22 mA (by UP ▲ / DOWN ▼ key) and save it as above.</p> <p>DEFAULT: hold last value</p>  |
|  | <p><b>damping time:</b> select required damping time (by UP ▲ / DOWN ▼ key) and save it as above.</p> <p>DEFAULT: 60 sec for liquids, 300 sec for solids</p>  |

**Note:** – Current output can also be programmed for inverted operation: 4 mA= 100% (Full), 20 mA= 0% (Empty)  
– Description of failures can be found under the chapter 7 Error codes.

### 5.2.5 Full parameter access

**Full Parameter Access is the highest programming level to access all features provided by the EchoTREK**

Description of all parameters can be found under the chapter “Parameter” (Chapter 6.).

| Keys                                      | Function  |
|---|---|
| ENTER ⊞ + NEXT ◀<br>(press for 3 seconds) | Enter or exit Full Parameter Access programming mode. |

In this programming mode, the display will indicate:

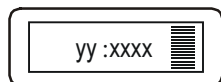

yy      Parameter Address (**P01, P02 ... P99**)  
xxxx    Parameter Value (dcba)  
    bargraph



Measuring is going on during programming in accordance with the old parameter set. New parameter set will be valid after returning to the Measurement to the Programming Mode.

### Steps and indications of the Full Parameter Access programming mode

| pressing <b>Keys</b> | while <b>Parameter Address is blinking</b>  | while <b>Parameter Value is blinking</b>  |
|----------------------|---|---|
| ENTER (E)            | Go to the Parameter Value   | Save the modification of the Parameter Value and return to the Parameter Address                                      |
| NEXT (←) + UP (↑)    | Cancel all modifications of the actual programming phase.<br>Pressing for 3 sec is required while CANCEL will be displayed for warning  | Neglect the modification of the Parameter Value. and return to the Parameter Address without saving the modifications |
| NEXT (←) + DOWN (↓)  | Reset entire device to Factory Default.<br>Since this action will reset all parameters, "LOAD" will appear on the display:<br>- to confirm, press<br>- to escape, press any other key | Display default of the Parameter Values<br>(it can be saved by pressing ENTER (E))                                    |
| NEXT (←)             | Move blinking (changeability) of the digit to the left  |   |
| UP (↑) / DOWN (↓)    | Modify the blinking digit (increase, decrease) or scroll up/down  |   |

## 6. PARAMETERS – DESCRIPTIONS AND PROGRAMMING

### 6.1 MEASUREMENT CONFIGURATION

P00: - cba Application/Engineering Units

Changing of this parameter will result in loading the full parameter set with the values of the factory default with the corresponding engineering units. Thus reprogramming may be necessary!

| a | Operating (measurement) mode |
|---|------------------------------|
| 0 | Liquid level measurement     |

| b | Engineering units<br>(according to "c") |      |
|---|---|------|
|   | Metric                                  | US   |
| 0 | m                                       | ft   |
| 1 | cm                                      | inch |

| c | Calculation system |
|---|--------------------|
| 0 | Metric             |
| 1 | US                 |

**Attention: mind the sequence!**  
When programming this parameter the right value "a" will be blinking first.

FACTORY DEFAULT: 000

**P01: - - ba Measurement Mode – Bargraph**

Parameter value „a” will determine the basic measurement value that will be displayed and proportional with the current output. Depending on the value of “a” process values as listed in the 3d column can also be displayed by pressing NEXT (←). For return to the display of the basic value the ENTER (Ⓔ) key should be pressed.

| Ba | Measurement Mode     | Display symbol | Displayed values                  |
|----|----------------------|----------------|-----------------------------------|
| 00 | Distance             | DIST           | Distance                          |
| 01 | Level                | LEV            | Level, Distance                   |
| 02 | Level in percentage  | LEV%           | Level %, Level, Distance          |
| 03 | Volume               | VOL            | Volume, Level, Distance           |
| 04 | Volume in percentage | VOL%           | Volume %, Volume, Level, Distance |

**Attention: mind the sequence!**  
**When programming this parameter the right value “a” will be blinking first.**

**P02: - - ba Calculation units**

| a | Temperature |
|---|-------------|
| 0 | °C          |
| 1 | °F          |

**Attention: mind the sequence!**  
**When programming this parameter the right value “a” will be blinking first.**

This table is interpreted according to P00(c), P01(a) and P02(c) and is irrelevant in case of percentage measurement ( P01(a)= 2 or 4 )

| b | Volume         |                 | Weight (set also P32) |            |
|---|----------------|-----------------|-----------------------|------------|
|   | Metric         | US              | Metric                | US         |
| 0 | m <sup>3</sup> | ft <sup>3</sup> | tons                  | lb (pound) |
| 1 | litre          | gallons         | tons                  | tons       |

### P03: - - - a Values displayed - Rounding

It is important to keep in mind that the instrument is measuring distance and all other variables will be calculated from this basic measurement.

#### Displayed VOL

| Displayed Value                     | Display Format                     |
|-------------------------------------|------------------------------------|
| 0,000 – 9,999                       | x,xxx                              |
| 10,000 – 99,999                     | xx,xx                              |
| 100,000 – 999,999                   | xxx,x                              |
| 1000,000 – 9999,999                 | xxxx,x                             |
| 10000,000 – 99999,999               | xxxxx,x                            |
| 100000,000 – 999999,999             | xxxxxx,x                           |
| 1 million – 9,99999*10 <sup>9</sup> | x,xxxx : e<br>(exponential format) |
| 1*10 <sup>10</sup> over             | (overflow) Err4                    |

Decimal point will be shifted with increasing value displayed. (See table at the left). Values over one million will be displayed in exponential format whereas the value (e) represents the exponent. Over the value of 1x10<sup>10</sup> Err4 (overflow) will be displayed.

#### Rounding

| Parameter Value "a" | Steps In The Displayed Value |
|---------------------|------------------------------|
| 0                   | 1 (no rounding)              |
| 1                   | 2                            |
| 2                   | 5                            |
| 3                   | 10                           |
| 4                   | 20                           |
| 5                   | 50                           |

A couple of millimetres of fluctuation of the basic DIST value (e.g. due to waves) will be enlarged by the mathematical operations. This enlarged fluctuation in displaying VOL can (if disturbing) be avoided by rounding to be set in P03. Rounding value 2, 5, 10 etc represents the steps by which the calculated value will be changed in its (one or two) last digit(s).

Examples:

P03=1 steps by 2: 1,000; 1,002; 1,004

P03=5 steps by 50: 1,000; 1,050; 1,100 or 10,00; 10,05(0); 10,10(0);  
10,15(0)

(the 0 from the steps 50, 100, 150 etc will not be displayed)

FACTORY DEFAULT: 0

**P04 Zero point distance from the tank bottom (H) (Zero offset of the unit)**

This parameter is for arranging **zero offset which represents virtual expansion of the measurement range**. Obviously measurement will only be performed in the range, therefore in case of zero offset, displayed value will always be over zero and analogue output over 4 mA. Should zero offset not be required this parameter will be unchanged. Zero offset will be performed by setting in this parameter the value of distance between the tank bottom and the low-end position of the float. (See BASIC CONCEPT OF MEASUREMENT WITH NIVOTRACK on page 3)

Programming of the analogue output in **P10** will not be influenced by the zero offset.

FACTORY DEFAULT: 0

**P05: Zero point distance from the high-end position of the float (Zero offset within the range)**

This parameter is for arranging **zero offset within the measurement range**. Obviously this represents the reduction of the measurement range. The value of this parameter will be the distance between the required low (zero point) position and the high-end position of the float. Analogue output in **P10** should be programmed accordingly i.e. if  $P05 \neq 0$  then  $P05 = P10$ .

FACTORY DEFAULT: maximum measurement range i.e. distance between the low- and high-end position of the float

**P08: Fixed value of the analogue output**

This parameter is for setting analogue output for fixed value.

Setting value between 3.8 and 20.5 mA in this parameter this fixed value will appear on the analogue output. This also will overwrite all error indications and in case of  $P19 \neq 0$  the value of the output current will be (instead of 4 mA) the value set here.

If the parameter is 0, the current output will be according to the settings in the other parameters.

FACTORY DEFAULT: 0

## 6.2 CURRENT OUTPUT

**P10:** Value (of distance, level, volume or flow) assigned to 4 mA current output

**P11:** Value (of distance, level, volume or flow) assigned to 20 mA current output

Values are interpreted according to **P01(a)**. Please note that in case of programming for (LEV or VOL) % measurement the min and max value has to be entered in the relevant engineering units of LEV (m, ft) or VOL (m<sup>3</sup>, ft<sup>3</sup>).

Assignment can be made so that the proportion between the change of the (measured or calculated) process value and the change of the current output be either direct or inverse. E.g. level 1 m assigned to 4mA and level 10 m assigned to 20 mA represents direct proportion and level 1 m assigned to 20 mA and level 10 m assigned to 4 mA represents the inverse proportion.

Remember. if P05≠0 then P05 = P10!

FACTORY DEFAULT: P10 = 0 and P11 = measurement range (m)

**P12: - - - a** Error indication by the current output

In case of error the NIVOTRACK will provide one of the current outputs below. (For errors and their interpretation see Chapter 7).

| a | ERROR INDICATION (ACCORDING TO NAMUR) |
|---|---------------------------------------|
| 0 | Hold last value                       |
| 1 | 3.8 mA                                |
| 2 | 22 mA                                 |

FACTORY DEFAULT: 0

**P19:** HART address (applies for models with HART)

The short address of the unit can be selected for 0 to 15. If one unit is involved the address should be 0 (thus P19=0) and the 4-20mA is operational. In Multidrop applications (with more than one unit) the address should be other than 0-tól P19≠0, and the output will be fixed to 4mA provided P08=0.

FACTORY DEFAULT: 0

## 6.3 MEASUREMENT OPTIMISATION

### P20: --- a Damping

This parameter can be used to reduce unwanted fluctuation of the display and output.

| a | Damping time (seconds) | LIQUIDS                     |                                     |
|---|------------------------|-----------------------------|-------------------------------------|
|   |                        | None/moderate fume or waves | Heavy/dense fume or turbulent waves |
| 0 |                        | no filter                   |                                     |
| 1 | 3                      | applicable                  | not recommended                     |
| 2 | 6                      | recommended                 | applicable                          |
| 3 | 10                     | recommended                 | recommended                         |
| 4 | 30                     | recommended                 | recommended                         |
| 5 | 60                     | recommended                 | recommended                         |

FACTORY DEFAULT: 60 sec

### P32: Specific gravity [kg/dm<sup>3</sup>] or [lb/ft<sup>3</sup>] depending on setting in P00 (c)

Entering a value (other than "0") of specific gravity in this parameter, the weight will be displayed (instead of VOL) in tons or lb depending on setting in P00(c) and P02(b).

**Factory default: 0**

## 6.4 VOLUME MEASUREMENT

P40: -- ba Tank shape

| ba | Tank shape  | Also to be set            | <p style="text-align: center;"><b>Attention!</b><br/>The value „a” determining the shape of the tank should be set first.</p> |
|----|---|---------------------------|---|
| b0 | Standing cylindrical tank shape (value of “b” as below) | P40 (b), P41              |   |
| 01 | Standing cylindrical tank with conical bottom           | P41, P43, P44             |   |
| 02 | Standing rectangular tank (with chute)                  | P41, P42, (P43, P44, P45) |   |
| b3 | Lying cylindrical tank shape (value of “b” as below)    | P40 (b), P41, P42         |   |
| 04 | Spherical tank  | P41                       |   |

FACTORY DEFAULT: 00

P41-45: Tank dimensions

Standing cylindrical tank with hemispherical bottom a = 0

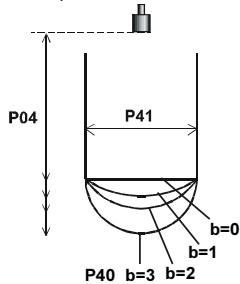

Lying cylindrical tank a = 3

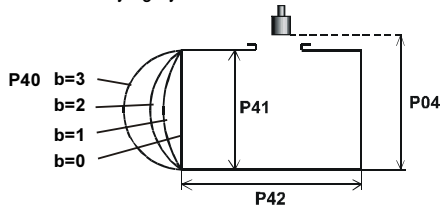

Standing cylindrical tank with conical bottom a = 1 ; b = 0

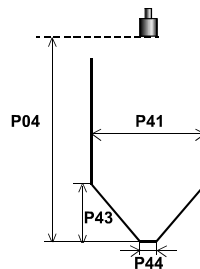

Standing rectangular tank with or without chute a = 2 ; b = 1

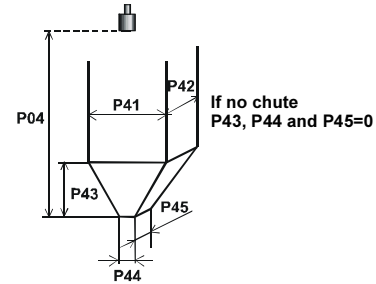

Spherical tank a = 4 ; b = 0

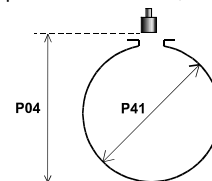



## 6.5 32-POINT LINEARISATION

### P47: --- a Linearisation

Linearisation is the method of assigning requested (calibrated or calculated) values to level values measured by the transmitter, where the assignment will be defined by data pairs. This can be used (as LEVEL  $\Rightarrow$  VOLUME conversion) for instance in case of a horizontal, cylindrical tank

| a | Linearisation         |
|---|-----------------------|
| 0 | OFF (FACTORY DEFAULT) |
| 1 | ON                    |

### P48: Linearisation table

Data-pairs of the linearisation table are handled in a 2x32 matrix, consisting of two columns.

| Left column "L" | Right column "r"  |
|-----------------|---|
| LEVEL measured  | LEVEL or VOLUME or FLOW to be transmitted and displayed |

The left column values (indicated on the display as "L") contain the measured LEVEL values. The right column values (indicated on the display as "r") contain the calibrated values and are interpreted according to the selected measurement value in **P01(a)**.

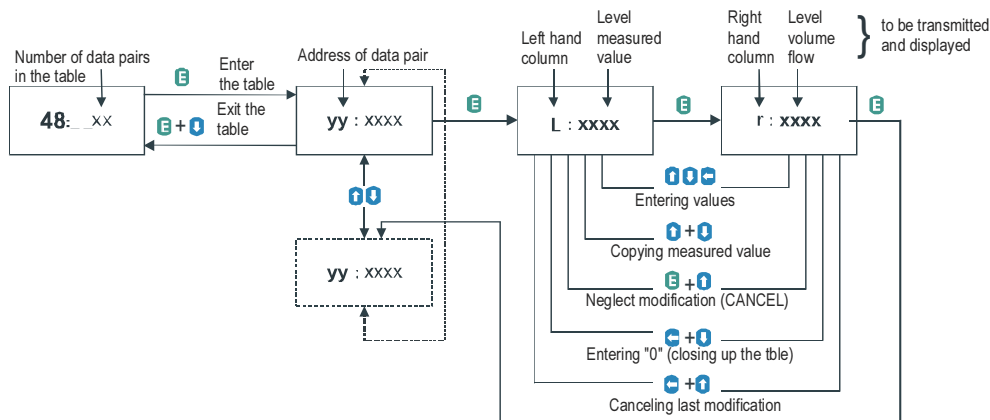

### Conditions of correct programming of the data pairs

| Left column "L" | Right column "r" |
|-----------------|------------------|
| L(1)= 0         | r(1)             |
| L(i)            | r(i)             |
| :               | :                |
| L(j)            | r(j)             |

The table must always start with: L(1)= 0 and r(1)= value (assigned to 0 level)

The table must be ended either with the 32<sup>nd</sup> data pair i.e. j=32 or if the linearisation table contains less than 32 data-pairs j<32, the table must be closed by a level value "0" e.g. L(j<32)= 0.

The NIVOTRACK will ignore data after recognising level value "0" with serial number other than "1".

If the above conditions are not met, error codes will be displayed (see chapter: Error Codes).

## 6.6 INFORMATIONAL PARAMETERS (READ OUT PARAMETERS)

### P60: Overall operating hours of the unit (h)

Indication varies according to the elapsed time:

| Operating hours | Indication form                      |
|-----------------|--------------------------------------|
| 0 to 999.9h     | xxx,X                                |
| 1000 to 9999h   | xxxx                                 |
| Over 9999h      | X,xx: e meaning x,xx 10 <sup>e</sup> |

### P61: Time elapsed after last switch-on (h)

Indication same as in P60.

## 6.7 SERVICE PARAMETERS

### P80: Current output test (mA)

Going to this parameter, the actual current output (corresponding to the measured process value) will be displayed. By pressing ENTER (E) the (now blinking) current value can be set for any value between 3,9 and 20.5 mA. The current output has to show the same value which can be checked by an ampere meter, according to the description under 4.4. Press ENTER (E) to quit test mode and return the parameter address

### P97: b:a.aa Software code

a.aa: Number of the software version

b: Code of the special version

## 6.8 SIMULATION

This function enables the user to test the settings of the outputs. The EchoTREK can simulate the static or continuous change of level according to the simulation cycle time, high level and low level set in P85, P86 and P87. (The simulation levels must be within the programmed measuring range set in P04 and P05.)

After selecting simulation type in P85 and setting simulation values Measurement Mode has to be re-entered. While the EchoTREK is in simulation mode the DIST, LEV or VOL symbol will be blinking. To quit Simulation Mode P84= 0 should be set.

### P84: - - - x Selection of the simulation

| X | Simulation type   |
|---|---|
| 0 | No simulation   |
| 1 | The level changes continuously up and down between the level values set in P86 and P87 with a cycle time set in P85 |

FACTORY DEFAULT: 0

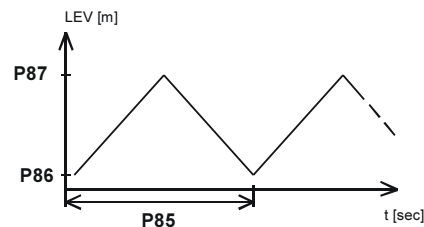

### P85: Cycle time for simulation (s)

### P86: Simulated low level value (m/ft)

### P87: Simulated high level value (m/ft)

## 6.9 ACCESS LOCK

### P99: dcba Access Lock by Secret Code

The purpose of this feature is to provide protection against accidental (or intentional) re-programming of parameters. The Secret Code can be any value other than **0000**. Setting a Secret Code will automatically be activated when the EchoTREK is returned to the Measurement Mode. If the Secret Code is activated, the parameters can only be viewed, this is indicated by the a flashing colon ":" between the parameter address and the parameter value. In order to program the device locked by a secret code, first enter the Secret Code in **P99**. The Secret Code is re-activated each time the EchoTREK is returned to Measurement Mode.

To delete the Secret Code, enter the Secret Code in **P99**. After confirming it with **[E]** re-enter the parameter **P99** and enter **0000**.

**[dcba (Secret Code) ] → [E] → [E] → [0000] → [E] ⇒ Secret Code deleted**

## 7. ERROR CODES

| Error Code | Error description  | Causes and solutions   |
|------------|--|--|
| 1          | Memory error   | Contact local agent  |
| 2          | Probe failure  | Contact local agent  |
| 3          | Hardware (EEPROM communication) error  | Contact local agent  |
| 4          | Display overflow   | Check settings   |
| 5          | Probe or calibration error (level in the dead band)  | Check installation and calibration   |
| 6          | The measurement is at the reliability threshold. No clear signal for evaluation (noise, electromagnetic disturbance) | Eliminate source of disturbance, try better location for the probe.  |
| 12         | Linearisation error: both L(1) and L(2) are zero (no valid data-pairs)   | See the Section "Linearisation"  |
| 13         | Linearisation error: there are two identical L(i) data in the table  | See the Section "Linearisation"  |
| 14         | Linearisation table error: the r(i) values are not monotone increasing   | See the Section "Linearisation"  |
| 15         | Linearisation error: no value assigned to the measured value   | See the Section "Linearisation"  |
| 16         | The check sum of the program in the EEPROM is wrong  | Change any one of the parameters and return to the Measurement Mode. Is this trial unsuccessful contact local agent. |
| 17         | Parameter consistency failure (error corrected automatically)  | Check programming  |
| 18         | Hardware failure (failure of the master PCB)   | Contact local agent  |

## 8. PARAMETER TABLE

| Par. | Page | Description  | Value |   |   |   | Par. | Page | Description             | Value |   |   |   |
|------|------|--|-------|---|---|---|------|------|-------------------------|-------|---|---|---|
|      |      |  | d     | c | b | a |      |      |                         | d     | c | b | a |
| P00  |      | Applied. engineering units   |       |   |   |   | P28  | N.A. |                         |       |   |   |   |
| P01  |      | Measurement Mode   |       |   |   |   | P29  | N.A. |                         |       |   |   |   |
| P02  | 27   | Calculation units  |       |   |   |   | P30  | N.A. |                         |       |   |   |   |
| P03  | 27   | Rounding   |       |   |   |   | P31  | N.A. |                         |       |   |   |   |
| P04  | 29   | Maximum Measuring Distance   |       |   |   |   | P32  | 31   | Specific gravity        |       |   |   |   |
| P05  | 29   | Zero point distance from the high-end position of the float Distance |       |   |   |   | P33  |      | N.A.                    |       |   |   |   |
| P06  |      | N.A.   |       |   |   |   | P34  |      | N.A.                    |       |   |   |   |
| P07  |      | N.A.   |       |   |   |   | P35  |      | N.A.                    |       |   |   |   |
| P08  | 32   | Fixed value of the analogue output                                   |       |   |   |   | P36  |      | N.A.                    |       |   |   |   |
| P09  |      | N.A.   |       |   |   |   | P37  |      | N.A.                    |       |   |   |   |
| P10  | 30   | Value assigned to „4 mA”   |       |   |   |   | P38  |      | N.A.                    |       |   |   |   |
| P11  | 26   | Value assigned to „20 mA”  |       |   |   |   | P39  |      | N.A.                    |       |   |   |   |
| P12  | 30   | “Error” indication by the current output                             |       |   |   |   | P40  | 32   | Selection of tank shape |       |   |   |   |
| P13  |      | N.A.   |       |   |   |   | P41  | 32   | Dimensions of tank      |       |   |   |   |
| P14  |      | N.A.   |       |   |   |   | P42  | 32   | Dimensions of tank      |       |   |   |   |
| P15  |      | N.A.   |       |   |   |   | P43  | 32   | Dimensions of tank      |       |   |   |   |
| P16  |      | N.A.   |       |   |   |   | P44  | 32   | Dimensions of tank      |       |   |   |   |
| P17  |      | N.A.   |       |   |   |   | P45  | 32   | Dimensions of tank      |       |   |   |   |
| P18  |      | N.A.   |       |   |   |   | P46  |      |                         |       |   |   |   |
| P19  |      | HART address   |       |   |   |   | P47  | 33   | Linearisation           |       |   |   |   |
| P20  | 31   | Damping  |       |   |   |   | P48  | 33   | Linearisation table     |       |   |   |   |
| P21  |      | N.A.   |       |   |   |   | P49  |      | N.A.                    |       |   |   |   |
| P22  |      | N.A.   |       |   |   |   | P50  |      | N.A.                    |       |   |   |   |
| P23  |      | N.A.   |       |   |   |   | P51  |      | N.A.                    |       |   |   |   |
| P24  |      | N.A.   |       |   |   |   | P52  |      | N.A.                    |       |   |   |   |
| P25  |      | N.A.   |       |   |   |   | P53  |      | N.A.                    |       |   |   |   |
| P26  |      | N.A.   |       |   |   |   | P54  |      | N.A.                    |       |   |   |   |
| P27  |      | N.A.   |       |   |   |   | P55  |      | N.A.                    |       |   |   |   |

| Par. | Page | Description                         | Value |   |   |   |
|------|------|-------------------------------------|-------|---|---|---|
|      |      |                                     | d     | c | b | a |
| P56  |      | N.A.                                |       |   |   |   |
| P57  |      | N.A.                                |       |   |   |   |
| P58  |      | N.A.                                |       |   |   |   |
| P59  |      | N.A.                                |       |   |   |   |
| P60  | 34   | Overall operating hours of the unit |       |   |   |   |
| P61  | 34   | Time elapsed after last switch-on   |       |   |   |   |
| P62  |      | N.A.                                |       |   |   |   |
| P63  |      | N.A.                                |       |   |   |   |
| P64  |      | N.A.                                |       |   |   |   |
| P65  |      | N.A.                                |       |   |   |   |
| P66  |      | N.A.                                |       |   |   |   |
| P67  |      | N.A.                                |       |   |   |   |
| P68  |      | N.A.                                |       |   |   |   |
| P69  |      | N.A.                                |       |   |   |   |
| P70  |      | N.A.                                |       |   |   |   |
| P71  |      | N.A.                                |       |   |   |   |
| P72  |      | N.A.                                |       |   |   |   |
| P73  |      | N.A.                                |       |   |   |   |
| P74  |      | N.A.                                |       |   |   |   |
| P75  |      | N.A.                                |       |   |   |   |
| P76  |      | N.A.                                |       |   |   |   |
| P77  |      | N.A.                                |       |   |   |   |

| Par. | Page | Description            | Value |   |   |   |
|------|------|------------------------|-------|---|---|---|
|      |      |                        | d     | c | b | a |
| P78  |      | N.A.                   |       |   |   |   |
| P79  |      | N.A.                   |       |   |   |   |
| P80  | 35   | Current generator test |       |   |   |   |
| P81  |      | N.A.                   |       |   |   |   |
| P82  |      | N.A.                   |       |   |   |   |
| P83  |      | N.A.                   |       |   |   |   |
| P84  | 35   | Simulation mode        |       |   |   |   |
| P85  | 35   | Simulation cycle time  |       |   |   |   |
| P86  | 35   | Simulation low level   |       |   |   |   |
| P87  | 35   | Simulation high level  |       |   |   |   |
| P88  |      | N.A.                   |       |   |   |   |
| P89  |      | N.A.                   |       |   |   |   |
| P90  |      | N.A.                   |       |   |   |   |
| P91  |      | N.A.                   |       |   |   |   |
| P92  |      | N.A.                   |       |   |   |   |
| P93  |      | N.A.                   |       |   |   |   |
| P94  |      | N.A.                   |       |   |   |   |
| P95  |      | N.A.                   |       |   |   |   |
| P96  |      | N.A.                   |       |   |   |   |
| P97  | 35   | Software code          |       |   |   |   |
| P98  |      | N.A.                   |       |   |   |   |
| P99  | 36   | Access lock            |       |   |   |   |

mba3052a0600p\_01  
November 2004.

NIVELCO reserves the right to change technical data without notice.