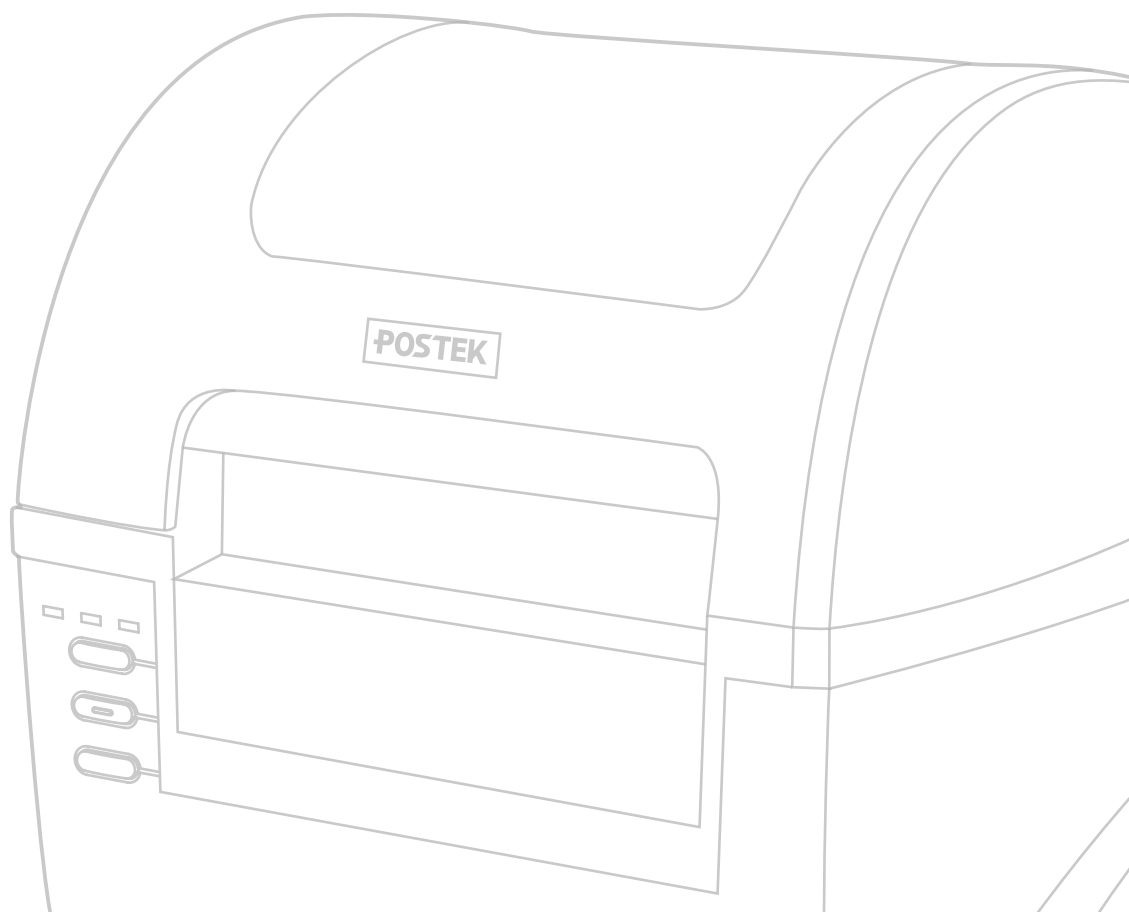




# User's Manual

## **C168 Series**

Barcode Label Printer



**FCC Notice**

This device complies with Part 15 of the FCC Rules. Operation is subject to the following two conditions: (1) this device may not cause harmful interference, and (2) this device must accept any interference received, including interference that may cause undesired operation.

This equipment may generate, use and/or radiate radio frequency energy. If not installed and used in full accordance with this User's Manual, interference to radio communications may occur. This equipment complies with the limits for a Class A Information Technology Equipment pursuant to Part 15 of the FCC Rules, which are designed to provide reasonable protection against such interference when operated in a commercial environment. Operation of this equipment in a residential area may also cause interference. In such case the user, at his/her expense, will be required to correct the interference using whatever means necessary.

**Trademarks**

POSTEK is a registered trademark by POSTEK Electronics Co., Ltd.

ARM is a registered trademark of Advanced RISC Machines Ltd.

Microsoft, Windows are registered trademarks of Microsoft Corporation.

**Copyright**

© 2006-2015 by Postek Electronics Co., Ltd. All rights reserved. Under the copyright laws, this manual cannot be reproduced in any form without the prior written permission of Postek. No patent liability is assumed, with respect to the use of the information contained herein.

POSTEK C168 Series Label Printer User's Manual

9th edition January 2015

**Disclaimer**

This manual has been validated and reviewed for accuracy. The instructions and descriptions it contains are accurate for the Postek C168 Series label printer at the time of this manual's distribution. However, succeeding printers and manuals are subject to change without notice. Postek assumes no liability for damages incurred directly or indirectly from errors, omissions or discrepancies between the printer and this manual.

Although this manual describes and details many issues which could possibly occur, the manufacturer cannot warrant against unpredictable conditions during the printing process. For problems such as the printer not working, lost or unclear print content, etc., the manufacturer and resellers are responsible for correcting these issues (according to Postek Printer Warranty Clauses). In no event shall the manufacturer or the resellers involved be liable for any damages whatsoever (including, without limitation, damages for loss of business profits, business interruption, loss of business information, or other pecuniary loss) arising from the use of, the results of use or inability to use this product, even if the manufacturer has been advised of the possibility of such damages.

## Important Safety Instructions

- ◆ Only qualified and trained service technicians should attempt to repair the printer.
- ◆ Do not place the printer on or near a heat source.
- ◆ Be sure that the output of the power adapter is 24VDC and your power source matches the rating listed on the power adapter. Be certain your power source is grounded.
- ◆ To avoid getting an electric shock, do not use a worn or damaged power cord. If the power cord becomes damaged or frayed, replace it immediately.
- ◆ Do not insert anything into the ventilation slots or openings on the printer.
- ◆ The printer and power adapter should never be operated in a location where either one can get wet. Personal injury may result.
- ◆ The printhead becomes hot while printing. To protect from damaging the printhead and risk of personal injury, avoid touching the printhead.
- ◆ To get increased printhead longevity and higher quality printouts, always use approved labels, tags and thermal transfer ribbons. Approved supplies can be ordered from your Postek authorized reseller.
- ◆ Static electricity that accumulates on the surface of the human body or other surfaces can damage or destroy the printhead or electronic components in this device. **DO NOT** touch the printhead or the electronic components with bare hands.
- ◆ Place the printer on a flat, firm, solid surface.
- ◆ Never operate in a high temperature environment.
- ◆ Turn off the power when not in use for extended periods.
- ◆ Follow all recommendations and setup instructions included in this manual.

### Warnings:

This is a Class A product. In a domestic environment this product may cause radio interference in which case the user may be required to take adequate measures (see FCC Notice).

Static electricity that accumulates on the surface of the human body or other objects can damage the print head or electronic components in the C168 Series printer. Observe proper electrostatic safety precautions when handling.

# Table of Contents

<b>Preface</b> .....	<b>1</b>
<b>Important Notice, Read Me First</b> .....	<b>1</b>
<b>Chapter 1: Introduction</b> .....	<b>2</b>
Printer Specifications .....	2
Specifications for Power Adapter .....	2
Contents of Box .....	3
Packing List .....	3
<b>Chapter 2: Setup and Use</b> .....	<b>5</b>
Setting up the Printer .....	5
Main Parts and Structures .....	5
Connecting the Printer .....	7
Interface Connection .....	8
Loading the Ribbon .....	8
Loading the Media .....	14
Standard Mode .....	14
Peel-off Mode .....	19
Cutting Mode .....	22
Using the External Media Stand .....	23
Install the Media Stand .....	23
Load Media Using External Media Stand .....	24
Adjusting the Position of Media Sensor .....	26
<b>Chapter 3: Operations and Settings</b> .....	<b>28</b>
Basic Operations .....	28
Power Switch .....	28
The Front Panel .....	28
Advanced Functions .....	29
Windows Driver .....	31
Label Software .....	31
<b>Chapter 4: Maintenance</b> .....	<b>32</b>
Cleaning the Printhead .....	32
Cleaning the Platen Roller .....	33
Cleaning the Printer Interior .....	33
<b>Chapter 5: Troubleshooting</b> .....	<b>34</b>
Error Indications .....	34
Miscellaneous .....	35
Vertical Blank Lines Appear .....	35
Printer Timeout Error Message .....	35
Data Sent but Not Printing .....	35
Poor Printing Quality .....	36
Recovery .....	36
<b>Appendix A: Interface Specifications</b> .....	<b>37</b>

**Appendix B: ASCII Table ..... 39**

# Preface

Your POSTEK C168 Series compact barcode label printer features innovative technology and superior quality workmanship. Boasting a rigid structure, a highly reliable motor and transmission system, and a large ribbon capacity of 360M, users enjoy minimal downtime and low service cost. With intuitive operations, the C168 is ideal for a wide range of applications.

This manual explains how to set up and begin using your C168 Series printer. It also provides detailed information on configuring your printer, basic operations, care and troubleshooting.

Please read this manual carefully before using the POSTEK C168 Series printer.

## Important Notice, Read Me First

The thermal printhead can be easily damaged due to its precision construction. A printhead damaged by misuse is not covered under the terms of the warranty. To ensure longevity of the printhead, please note the following:

1. DO NOT scrape or use tools that might damage the printhead surface.
2. To protect from corroding the printhead, DO NOT touch the printhead with bare hands.
3. DO NOT use thermal paper or thermal transfer ribbons which contain Na, K or Cl.
4. Keep printhead from any form of liquid or dampness.
5. Only use a cotton swab dipped in anhydrous isopropyl alcohol to clean the printhead.
6. Always use high-quality consumables:
  - When the printhead module is closed, pressure is placed directly onto the printhead; dirt such as paper scraps, sand, dust and glue can scrape or damage the printhead.
  - The printhead is also easily damaged by static electricity, which may be generated by poor quality ribbons.
7. Always inspect consumables for high quality before purchasing.

***Note: The C168 Series printer functions under Direct Thermal or Thermal Transfer print methods. Thermal Transfer is set as the factory default (requires ribbon for printing). However, if you need to print on Direct Thermal materials (ribbon is not required), please contact your printer supplier or service provider to reduce the printhead pressure. This can protect your printhead from early performance deterioration due to direct contact with the thermal media. Any physical printhead damage caused by direct thermal printing is not covered under warranty.***

# Chapter 1: Introduction

## Printer Specifications

Mode	C168/200s	C168/300s
Printing method	Thermal Transfer	
Printing resolution	203 dpi (8 dots/mm)	300 dpi (11.8 dots/mm)
Max printing speed	4 ips (101.6 mm)	3 ips (76.2 mm/s)
Max printing width	4.25"(108 mm)	4.17"(106 mm)
Max printing length	157" (4000 mm)	79" (2000 mm)
Memory	8 MB FLASH ROM, 16 MB SDRAM	
Media	Roll-feed, die-cut, continuous, fan-fold, tags, tickets in plain paper or thermal paper Width: 4.33" (110 mm) max., 0.98" (25 mm) min. Supply roll: OD 4" (102 mm) max., ID 1" (25.4 mm) min. Thickness: 0.003"~0.007" (0.08~0.18 mm), including liner	
Ribbon	Wax, Wax/Resin, Resin Ribbon roll: OD 3" (76.2 mm) max., ID 1" (25.4 mm) core Max width: 4.33" (110 mm); Max length: 984' (300 M)	
Fonts	Five built-in dot matrix ASCII fonts, user-downloadable TrueType Fonts	
Bar Code Types	1D Barcode: Code 39, Code 93, Code 128/subset A,B,C, Codabar, Interleave 2 of 5, UPC A/E 2 and 5 add-on, EAN-13/8/128, UCC-128. 2D Barcode: MaxiCode, PDF417, Data Matrix, QR Code.	
Media sensor	Reflective (Adjustable)/Transmissive	
Interfaces	RS-232 Serial, USB 2.0	
Power rating*	24 VDC, 2.5 A	
Weight	6.17lbs (2.8 kgs)	
Dimensions	W 9.3 x D 11.4 x H 7.8 inches (W 236 x D 291 x H 199 mm)	
Operation environment	Temperature: 32° F ~ +104° F (0° C ~ 40° C) Relative humidity: 5% - 85% non condensing	
Storage environment	Temperature: -40° F ~ +140° F (-40° C ~ 60° C) Relative humidity: 5% - 85% non condensing	
Optional items	Centronics Parallel Interface, 10/100Mb Ethernet, Rotary Cutter, External Rewinder, and Media Guide Adaptor	

## Specifications for Power Adapter

Input	AC 100~240 V, 50~60 Hz
Output	DC 24 V, 2.5 A
Environment	0° C ~ 40° C

## Contents of Box

Inspect the shipping carton(s) for possible shipping damage, if damage is discovered, notify the shipping company to report the nature and extent of the damage.

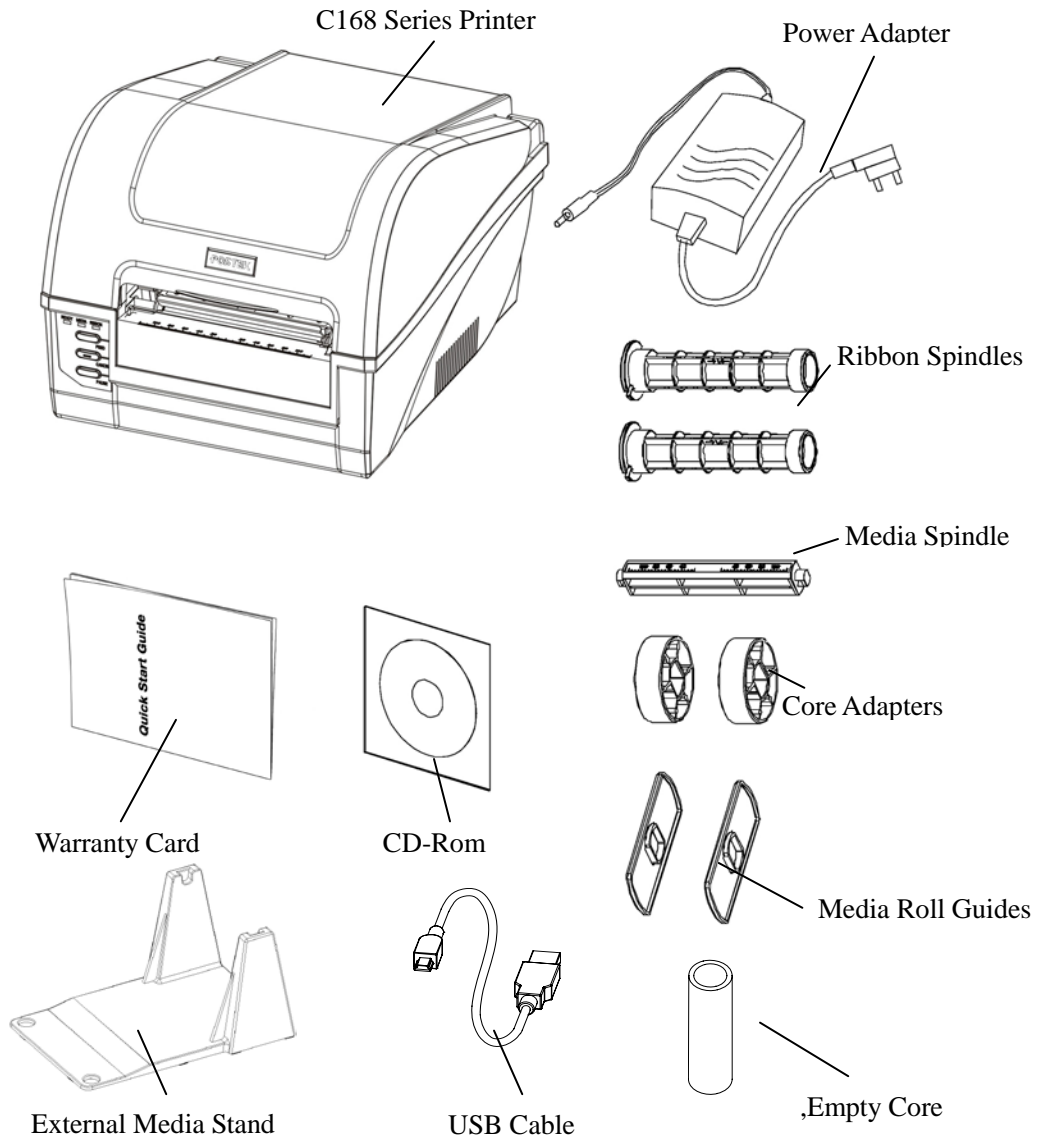
Please check the items according to the Packing List. If there are any items missing, notify your authorized reseller.

## Packing List

C168 Series Printer	1 pc
External Media Stand	1pc
Power Adapter	1 pc
USB interface cable	1 pc
Media Spindle	1 pc
Media Roll Guides	2 pcs
Media Core Adapters	2 pcs
Ribbon Spindles	2 pcs
Empty Core	1 pc
Quick Start Guide	1 pc
*CD-ROM pack	1 pc

**\*Note:** CD-ROM pack includes the printer driver, label software, C168-Series User's Manual, "How to install" video and Programming Manual.





**Figure 1: Printer and Accessories**

# Chapter 2: Setup and Use

## Setting up the Printer

Before setting up the printer consider the following:

1. Make sure there is adequate space around the printer for loading consumables and proper ventilation.
2. Make sure the printer is close to the host so the interface cable is easily accessible at either end.

## Main Parts and Structures

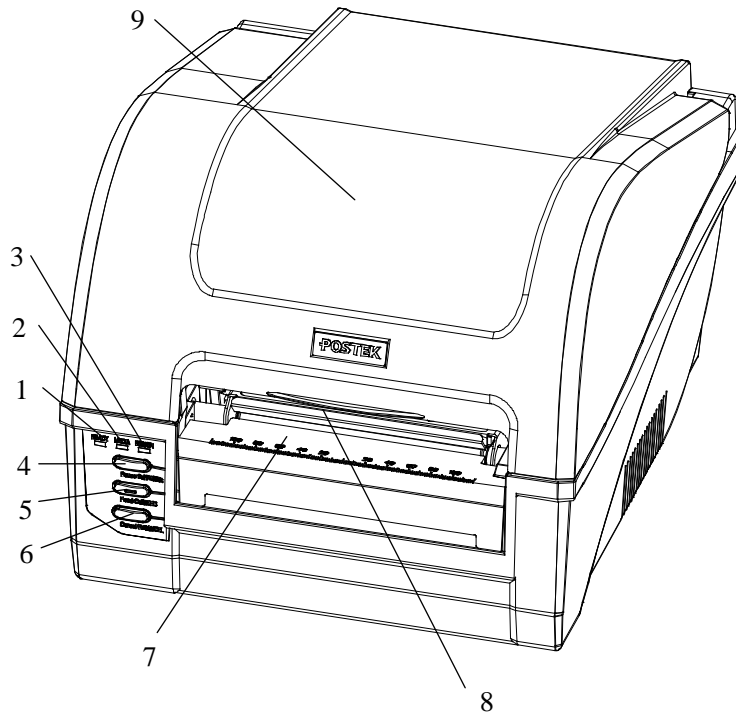
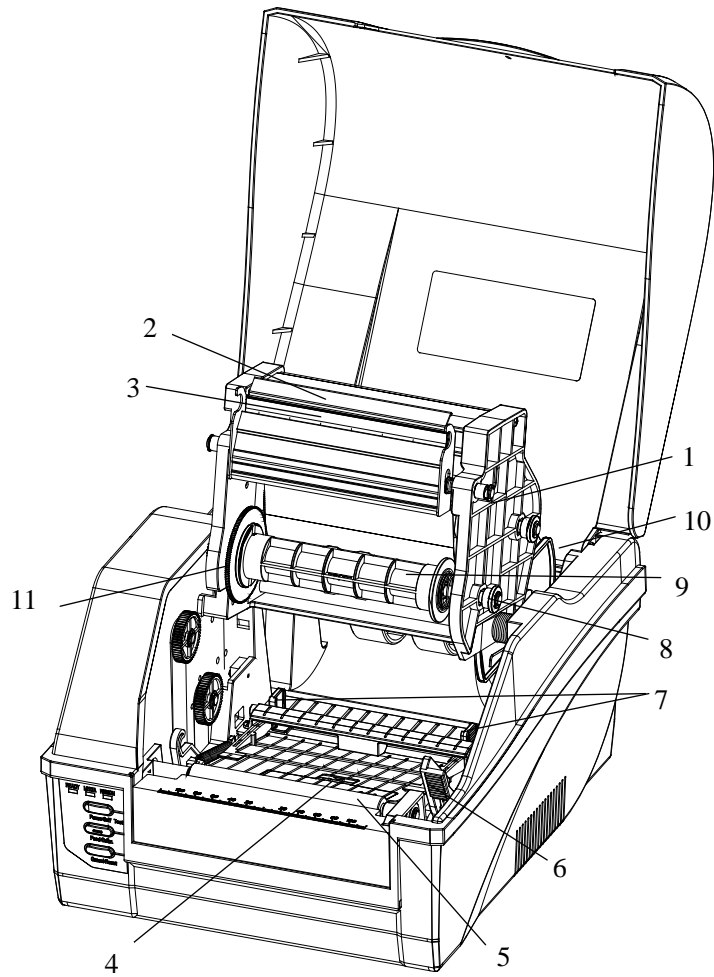
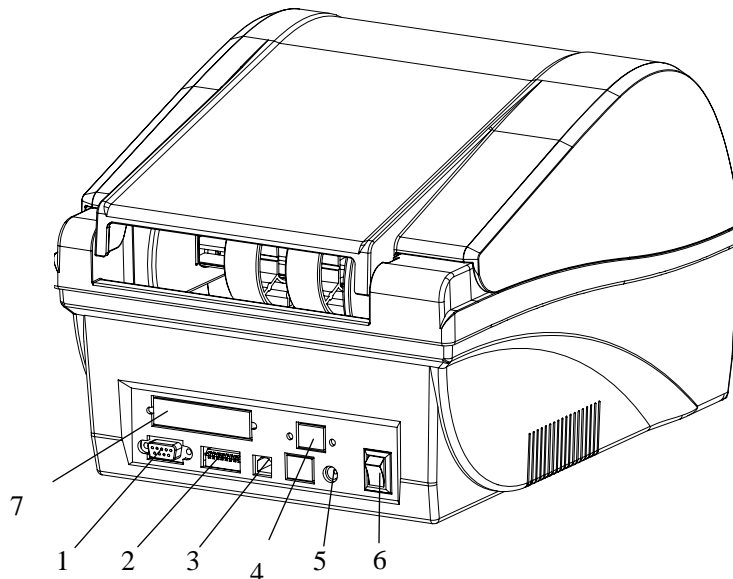


Figure 2

- |                     |                  |                 |
|---------------------|------------------|-----------------|
| 1. READY Indicator  | 4. PAUSE Button  | 7. Media Exit   |
| 2. MEDIA Indicator  | 5. FEED Button   | 8. Cover Handle |
| 3. RIBBON Indicator | 6. CANCEL Button | 9. Top Cover    |

**Figure 3**

- |                      |                            |                          |
|----------------------|----------------------------|--------------------------|
| 1. Printhead Module  | 5. Platen Roller           | 9. Ribbon Supply Spindle |
| 2. Printhead Bracket | 6. Printhead Release Lever | 10. Media Compartment    |
| 3. Printhead         | 7. Media Guide             | 11. Guide Wheel          |
| 4. Media Sensor      | 8. Ribbon Loading Knob     |                          |



**Figure 4**

- |                      |             |                 |
|----------------------|-------------|-----------------|
| 1. RS232 Serial Port | 3. USB Port | 5. DC IN Port   |
| 2. DIP Switches      | 4. Ethernet | 6. Power Switch |
| 7. Parallel Port     |             |                 |

## Connecting the Printer

### Warnings:

- (1) Do not use the printer near liquids or corrosive chemicals.
  - (2) Using the wrong power adapter may cause damage to your printer. POSTEK assumes no liability for any damage in such cases. The rating for the printer is 24VDC.
- 
1. Make sure the printer is switched OFF.
  2. Connect the power cord to the Power Adapter
  3. Connect the Power Adapter's DC output plug to the DC IN port on the back of the printer.
  4. Plug the power cord into a live wall outlet.

## Interface Connection

The C168 supports RS-232 Serial and USB interface connections.

**Note:** When connecting the C168 Series printer to a computer via the USB interface cable, make sure to utilize the same USB port used during the driver installation process, which enables the printer to retrieve needed commands or data from the PC. If the same USB port is not available or not known, then in the printer's Properties Dialogue Box, under the Ports tab, ensure the current port location is checked.

To connect:

1. Make sure the printer is powered OFF.
2. The printer will identify the communication port automatically.
3. The default values of printer port can be obtained from the self-test report. (See Chapter 2: Operation Basics/ Advanced Functions/ Self Test)
4. Cable configurations for Serial (RS-232C) interface is found in Appendix A of this guide.
5. Please take the following measures to reduce cable noise.
  - Restrict the length of the interface cable to less than 6' (1.83 M) if possible.
  - Keep the interface cable separate from power cords.

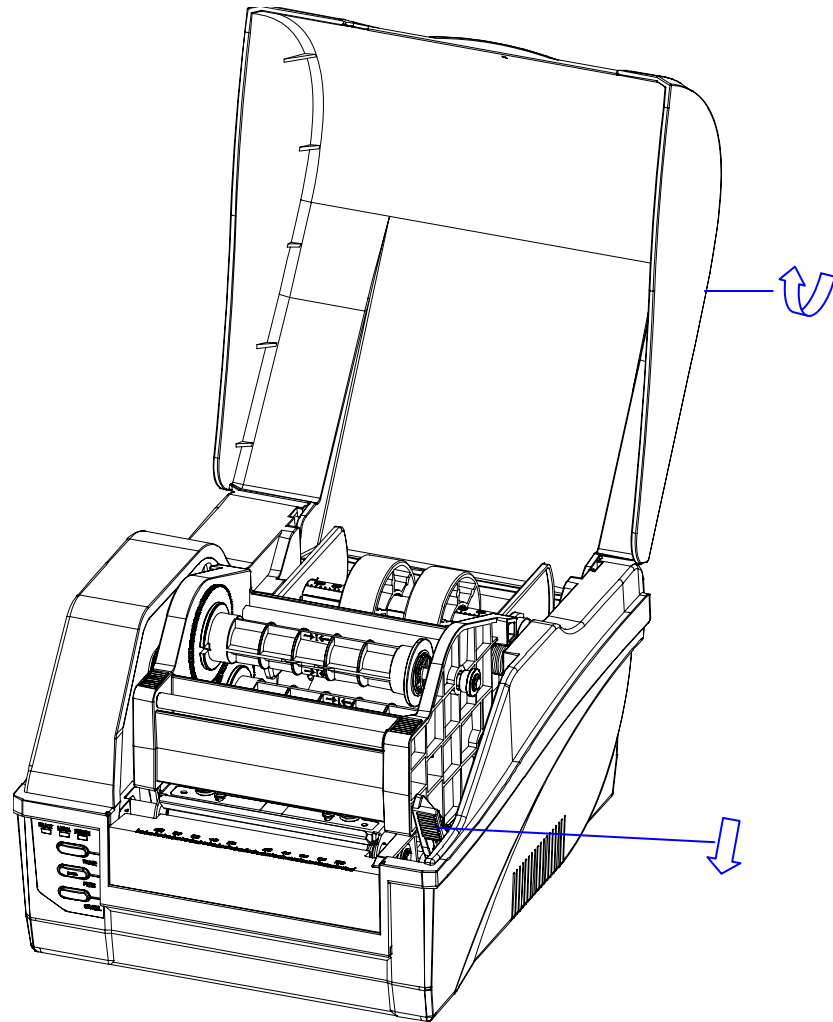
## Loading the Ribbon

### Warnings:

- (1) Load ribbon only when using the thermal transfer printing method. Remove any ribbon that may be loaded when using the direct thermal printing method.
- (2) When using a ribbon roll with a width less than 110m, please place the ribbon roll in the middle of the Ribbon Spindle corresponding to the symmetry symbol (→|←).
- (3) No need to load the ribbon when printing direct thermal media.

To install the ribbon:

1. Lift the top cover and push down the Printhead Release Lever to release the Printhead Module (see Figure 5-1).
2. Lift the Printhead Module to expose the ribbon supply spindle (see Figure 5-2).
3. Unwrap the ribbon pack and separate the ribbon roll and the core.
4. Slide the ribbon onto one of the Ribbon Spindles and place the core onto the other spindle (see Figure 5-3).
5. Load the Ribbon Spindle into the printer and route the ribbon through the Printhead Module (see Figure 5-4).
6. Wrap the end of the ribbon around the core (see Figure 5-5).
7. Load the core into the Ribbon rewinder (see Figure 5-6).
8. Turn the guide wheel on the left of the core to take up the loose ribbon and tighten the ribbon.
9. Close the Printhead Module and press down until it locks into place.



**Figure 5-1**

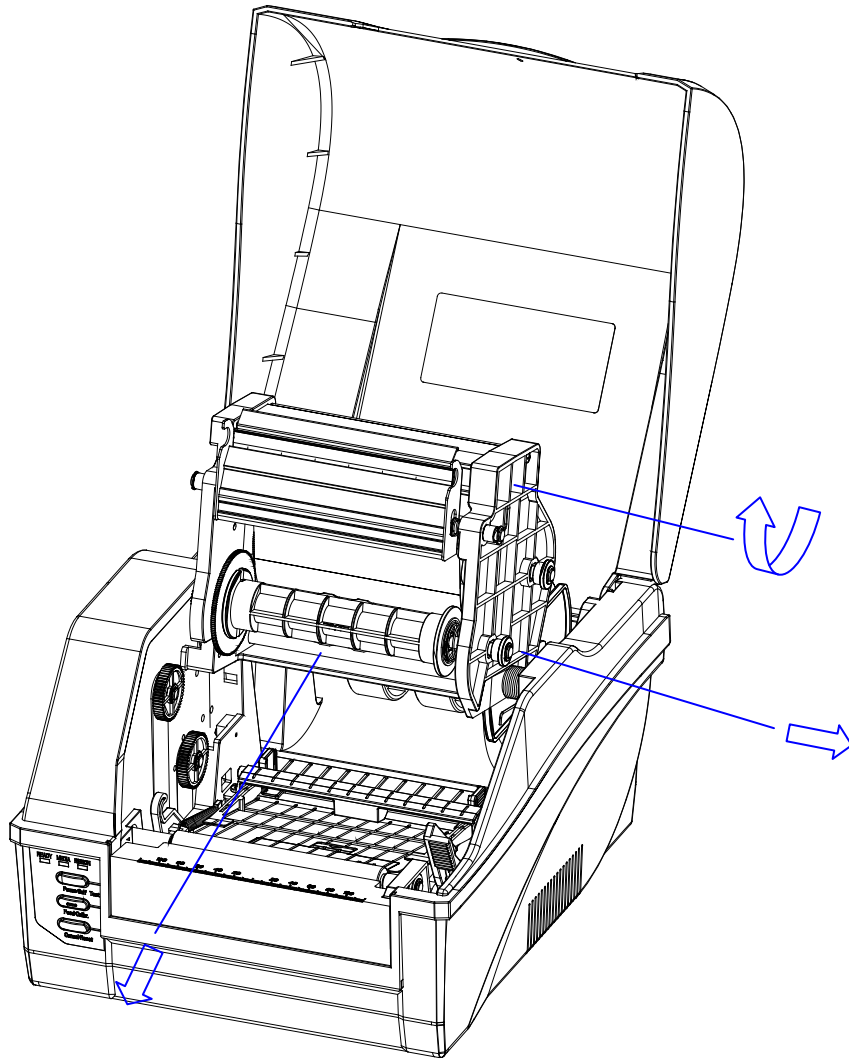


Figure 5-2

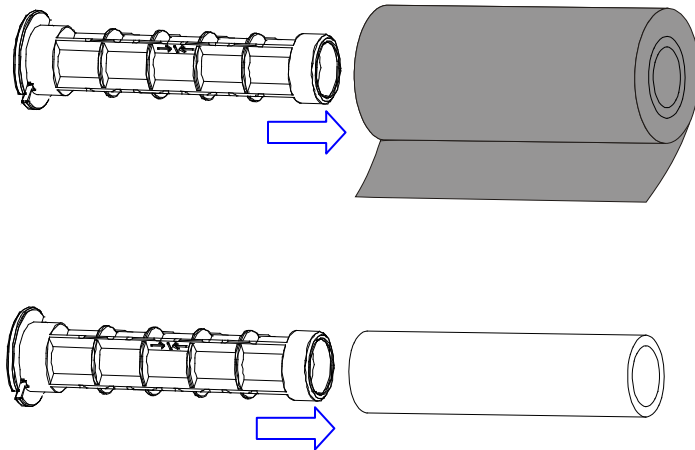
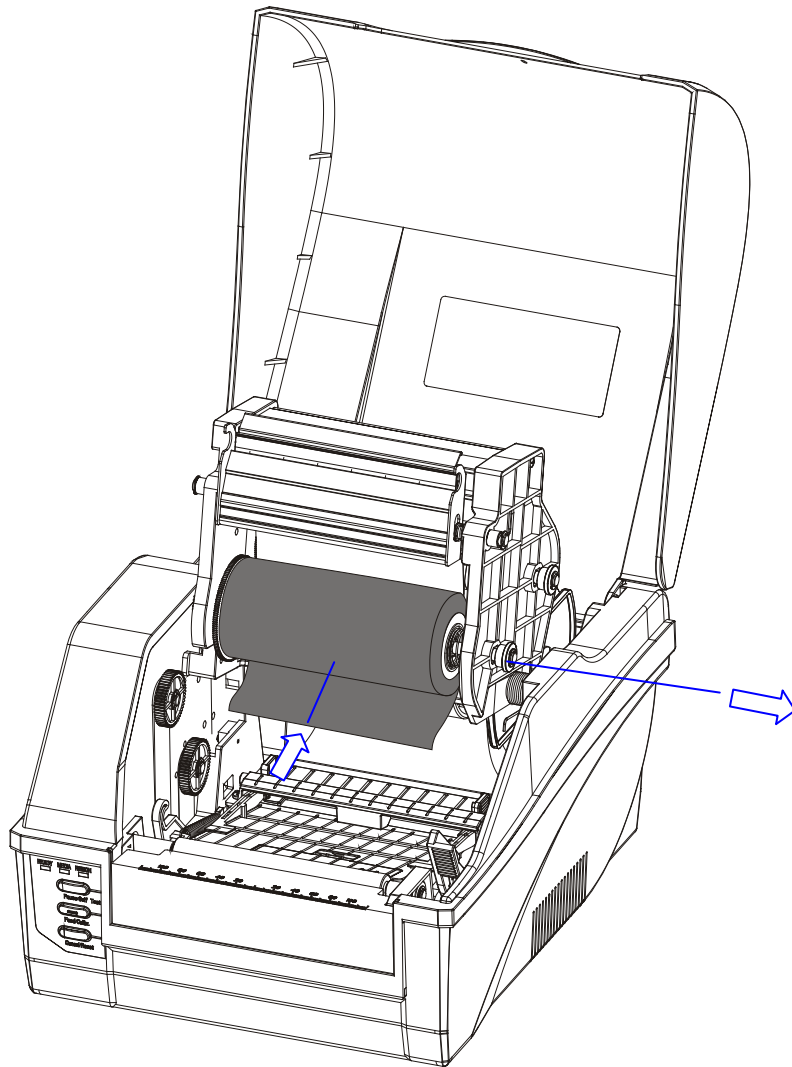
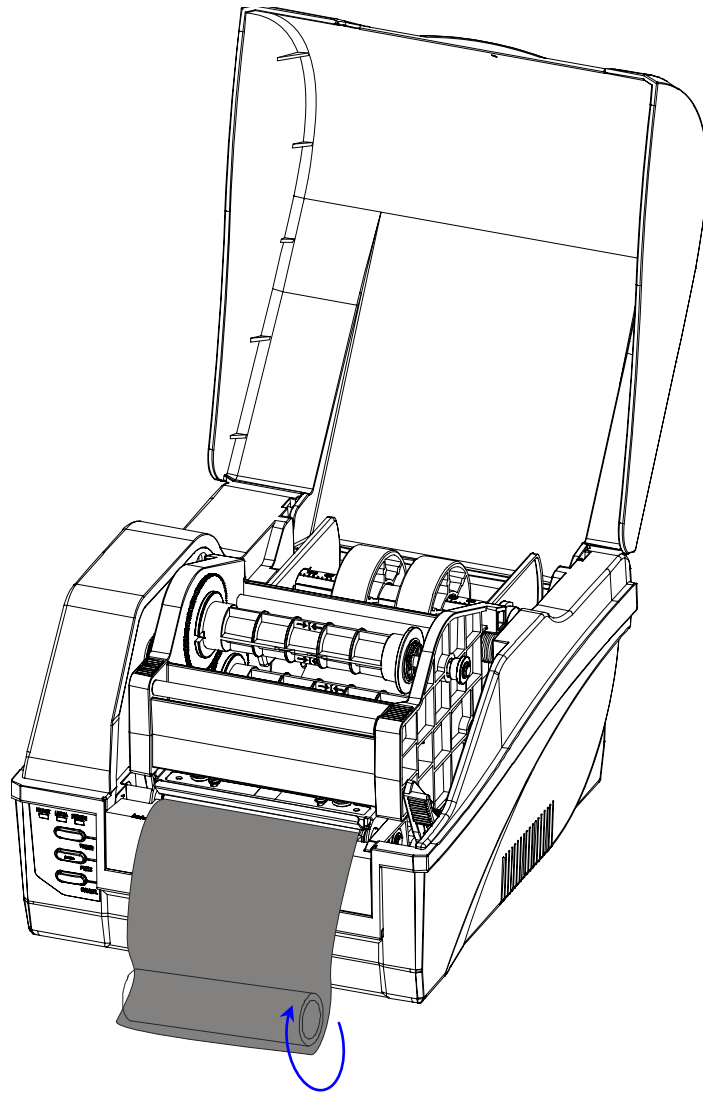


Figure 5-3

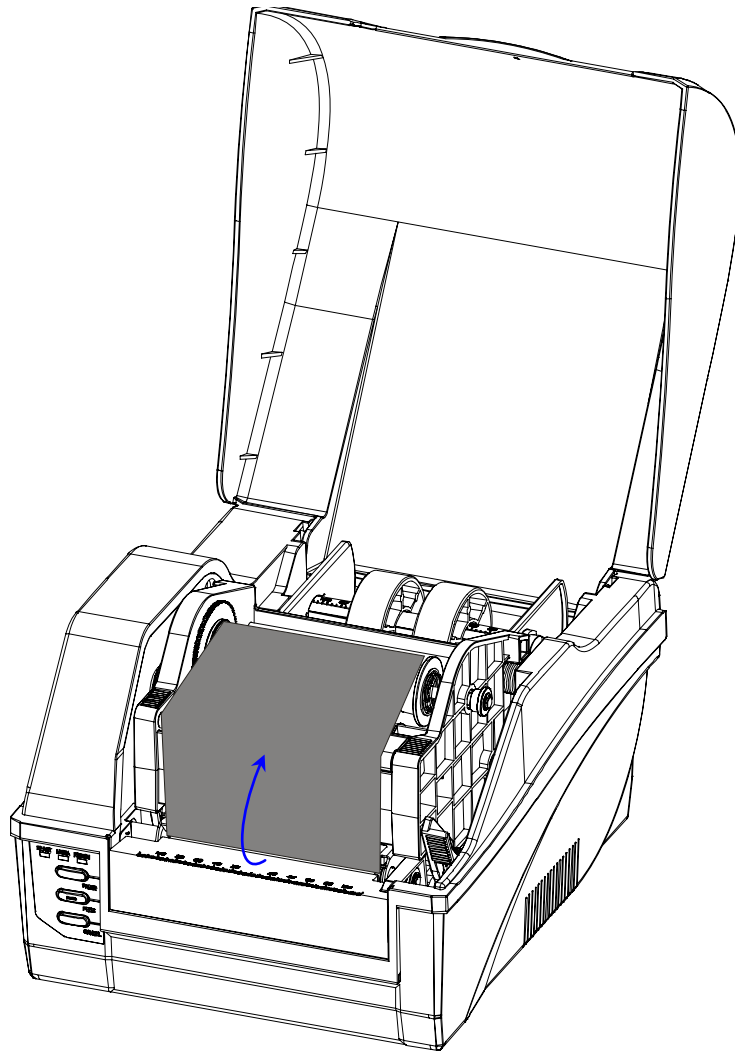


**Figure 5-4**





**Figure 5-5**



**Figure 5-6**

## Loading the Media

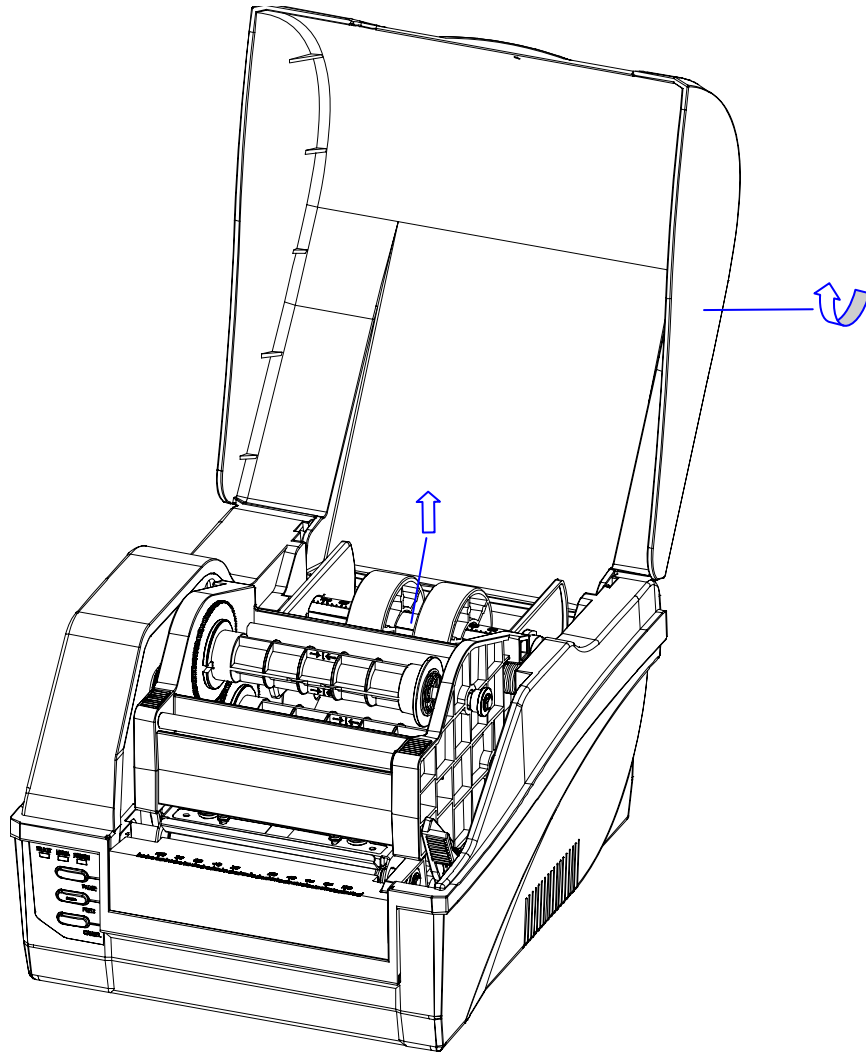
C168 printers can be operated in three different modes: Standard mode, Peel-off mode, or Cutting mode.

- In Standard mode, each printed label remains on the backing liner.
- In Peel-off mode, each printed label is peeled away from the backing liner automatically.
- In Cutting mode, the printer automatically cuts the label after it is printed.

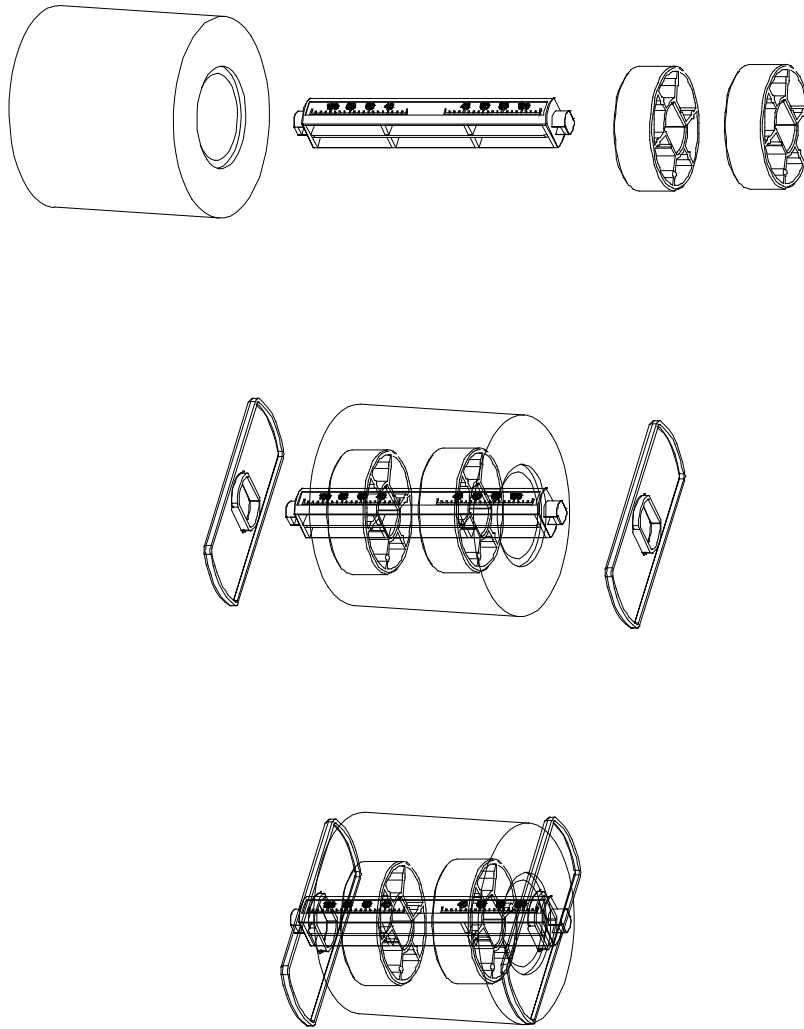
### Standard Mode

To load media into the C168 while using Standard Mode:

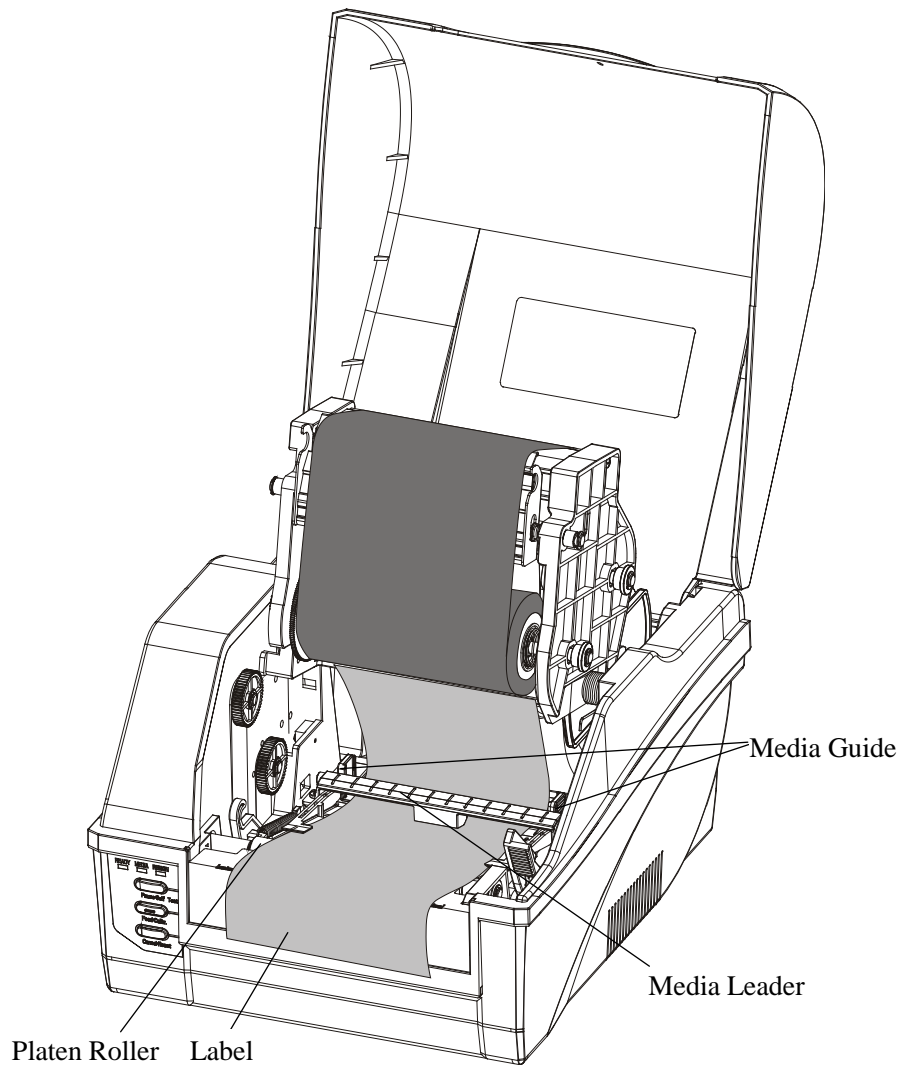
1. Lift up the top cover to expose the media compartment (see Figure 6-1).
2. Load a roll of media (labels facing up) on the Media Spindle, then slide the two Media Roll Guides, with smooth sides facing toward the media, onto the Media Spindle from each end until snug against the media. When placing a roll of media with a 3" ID core, please slide the two Core Adapters onto the Media Spindle first (see Figure 6-2).
3. Insert the entire unit into the media compartment in the printer.
4. Position the media roll in the middle of the Spindle, using the scale for guidance.
5. Release and lift the Printhead Module.
6. Route the media as shown in Figure 6-3.
7. Slide the Media Guide to the edge of the media.
8. Close the Printhead Module and press down until it locks into place (see Figure 6-4).
9. Close the cover and press the "Feed" button to feed the media and ensure proper tracking. If the printer does not correctly sense each label, it may be necessary to perform the Media Calibration procedure (found in the Operation Basics section.)



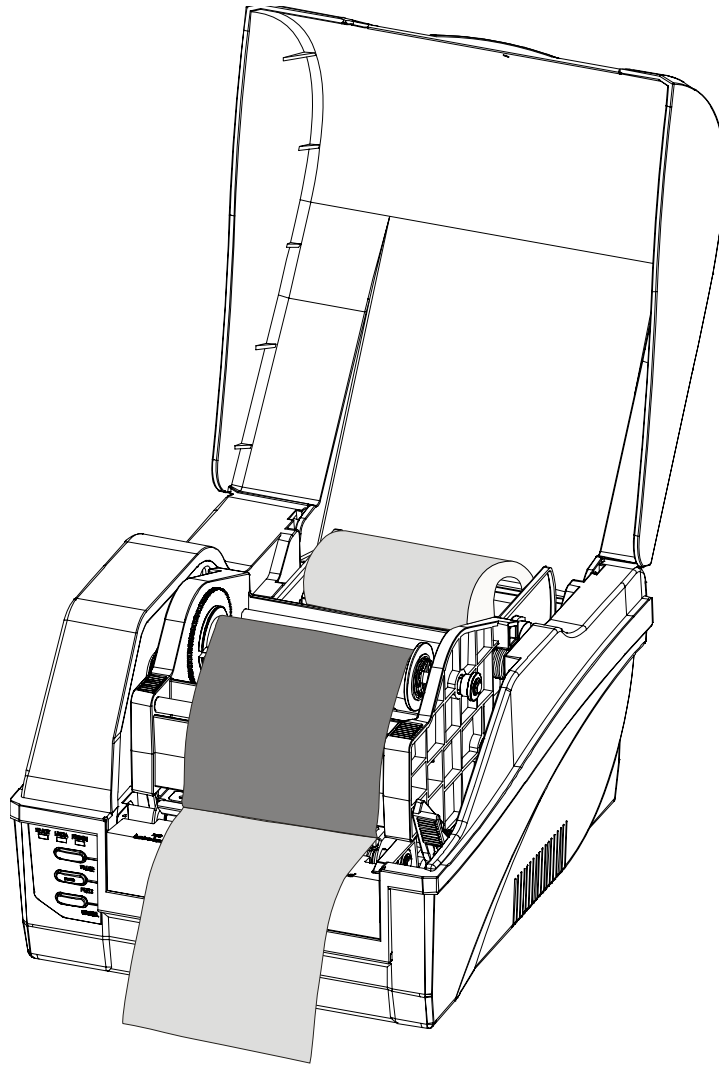
**Figure 6-1**



**Figure 6-2**



**Figure 6-3**



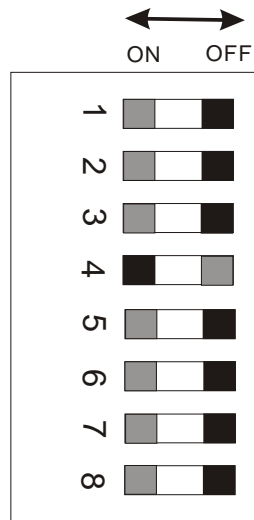
**Figure 6-4**

## Peel-off Mode

**Note:** Operating the printer in Peel-off mode requires the optional Peeler Kit.

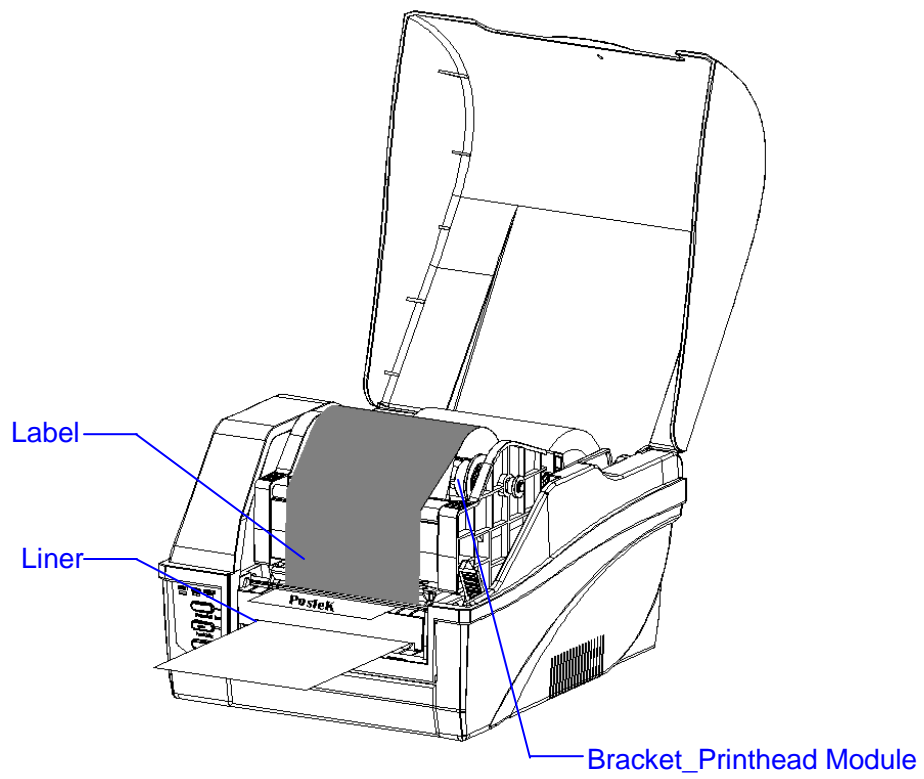
To load media into the C168 while using Peel-off Mode:

1. Set the 4<sup>th</sup> DIP Switch to the ON position to enable the peeler function (see Figure 6-5).
2. Turn on the printer.
3. Reset the Peeler Module: Press and hold the “Cancel” button for 4 seconds, until the 3 indicator lamps begin to blink simultaneously. Release the “Cancel” button and press it again one more time. Reset is complete.
4. Load a roll of ribbon. Push the Peeler Module to the “Open” state. Route the media as shown, pull the liner to make sure it is tight, and then turn the Peeler Module to the “Close” state. Peeler Module installation is complete (see Figure 6-6 and 6-7).

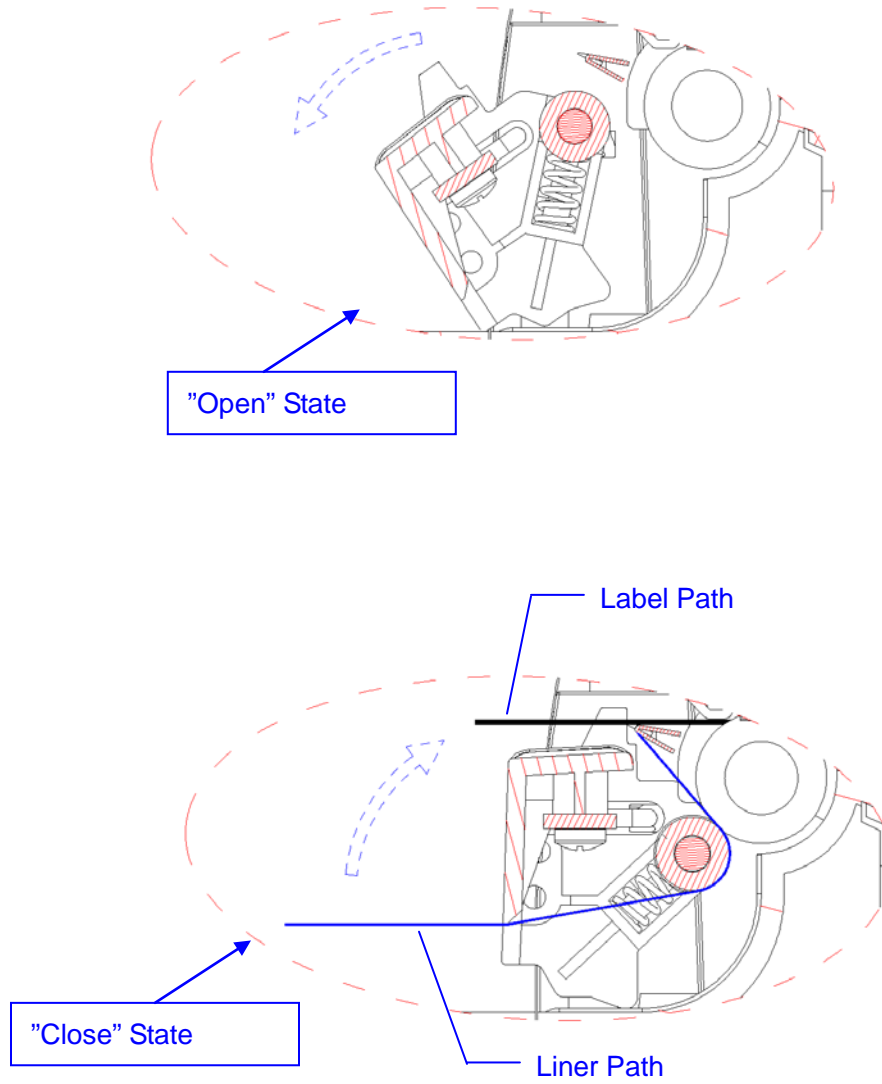


**Figure 6-5**





**Figure 6-6**

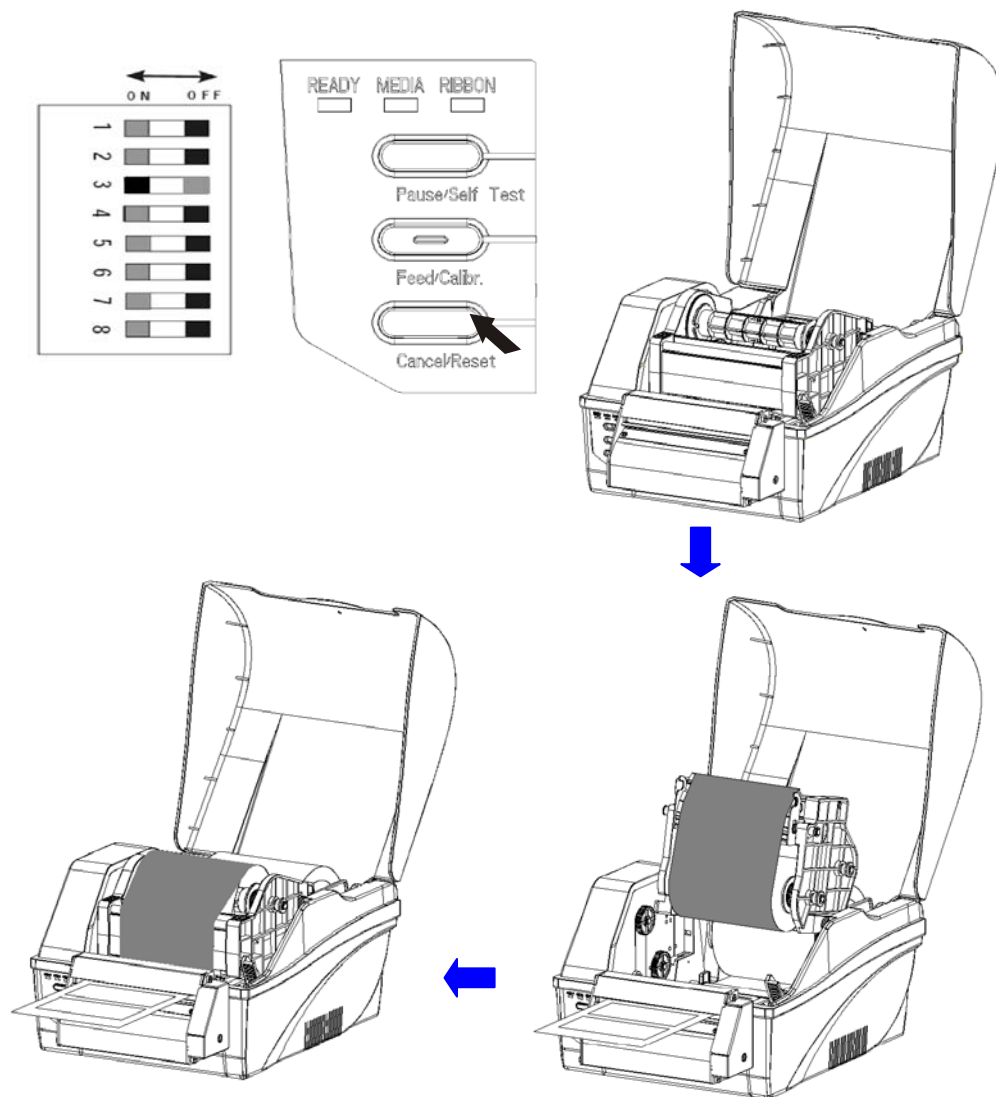


**Figure 6-7**

## Cutting Mode

**Note:** Operating the printer in Cutting mode requires the optional Rotary Cutter.

1. Set the 3<sup>rd</sup> DIP Switch to the ON position to enable the cutter function.
2. Turn on the printer.
3. Reset the printer: Press and hold the “Cancel” button for 4 seconds, until the 3 indicator lamps begin to blink simultaneously. Release the “Cancel” button and press it again one more time. The 3 indicator lamps stop blinking and remain lit. Reset is complete.
4. Load media as shown in Figure 6-8. The Rotary Cutter is now ready to use.



**Figure 6-8**

## Using the External Media Stand

If an External Media Stand is equipped with your C168 printer (stands may be an optional accessory), by utilizing the stand, the printer can accommodate media up to an 8" OD (204 mm) media roll.

### Install the Media Stand

Position the Media Stand under the printer, making sure the 2 positioning holes are lined up with the two rear printer feet, see Figure 6-9.

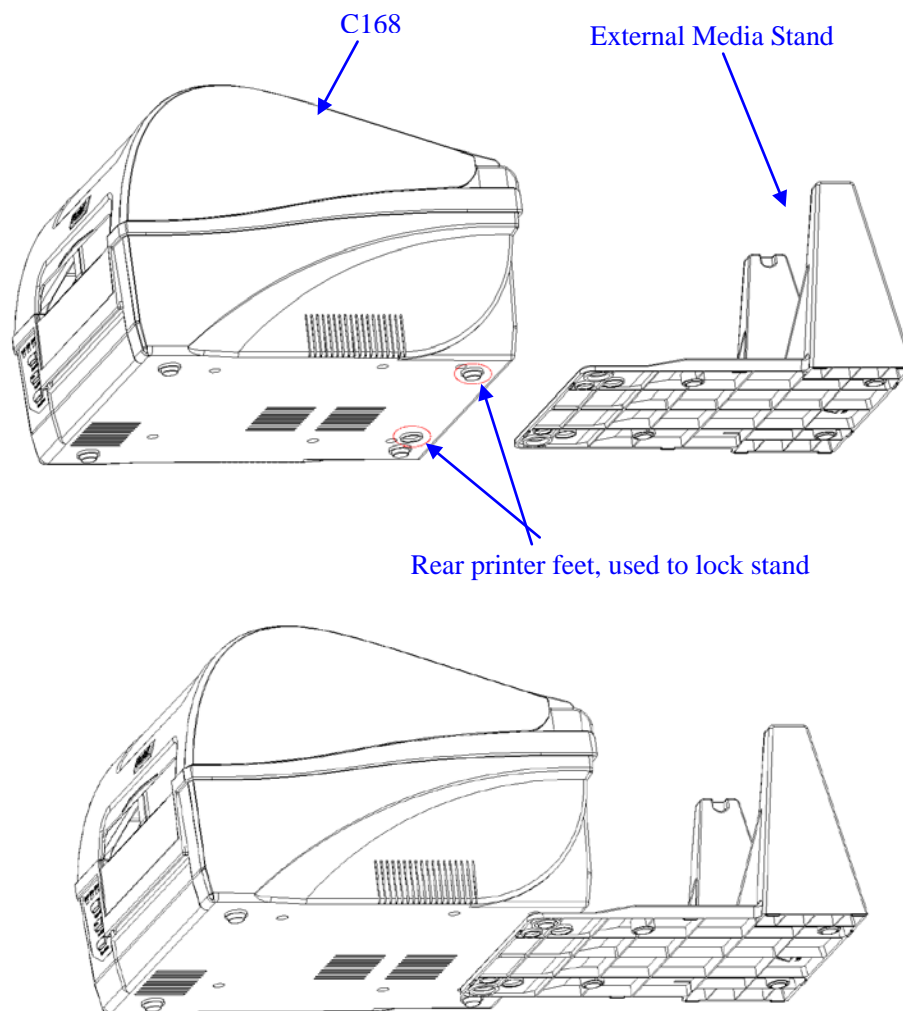
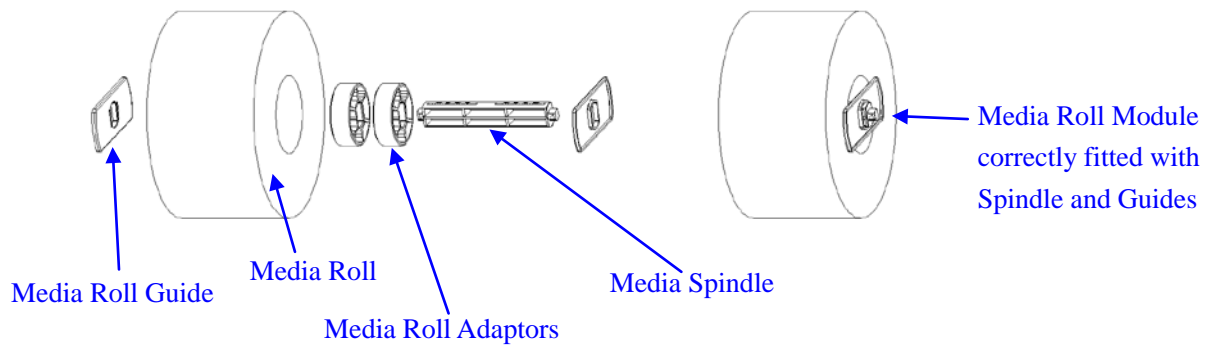


Figure 6-9

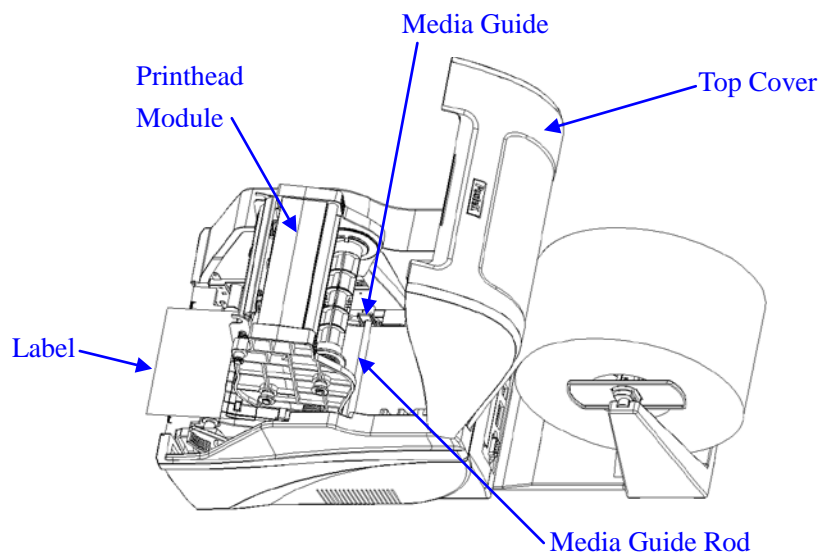
## Load Media Using External Media Stand

1. Insert a Media Spindle into the Media Roll core. For Media Rolls with extra large cores, use the Media Roll Adaptors first to create a snug fit.
2. Secure each end of the Media Roll core by placing a Media Roll Guide onto the Spindle, and slide each Guide to the edge of the Media Roll. Ensure the Media Roll is centered onto the Spindle. See Figure 6-10.



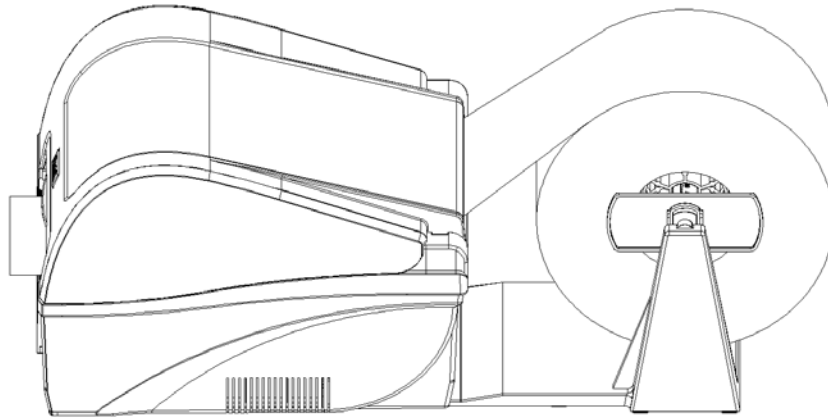
**Figure 6-10**

3. Open the top cover of C168. Release the printhead module, and place the entire Media Roll Module onto the External Media Stand.
4. Lead the media through the gap found between the top cover and the printer. Then, continue to lead the media under the media guide rod and above the platen roller. Adjust the 2 media guides to the edge of the media. See Figure 6-11.



**Figure 6-11**

5. Close the Printhead Module and the top cover. See Figure 6-12.



**Figure 6-12**

## Adjusting the Position of Media Sensor

1. Lift the top cover.
2. Push the Printhead Release Lever to release the Printhead Module.
3. Lift the Printhead Module to expose the Media Sensor cover (see Figure 7-1).
4. Remove the Media Sensor cover and slide the Media Sensor to the appropriate position (see Figure 7-3, 7-4 and 7-5).
5. Replace the media sensor cover.

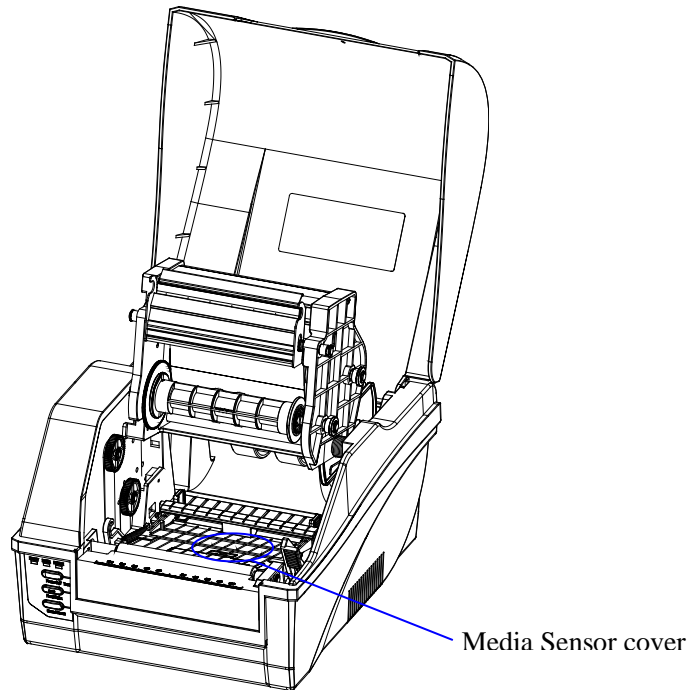


Figure 7-1

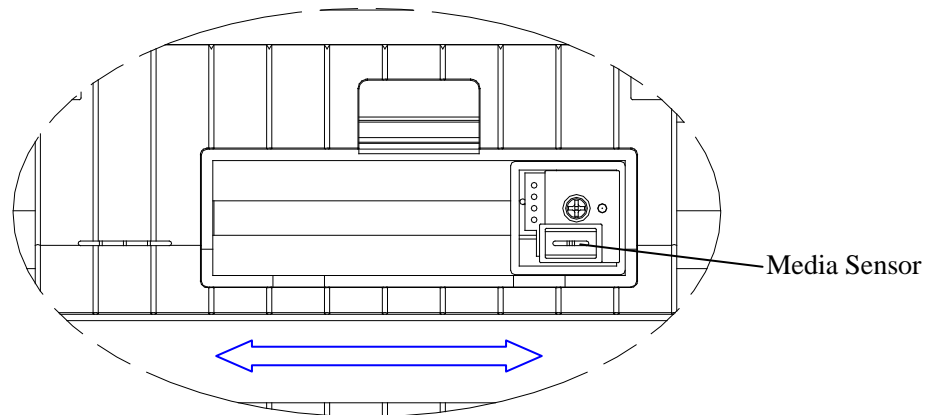
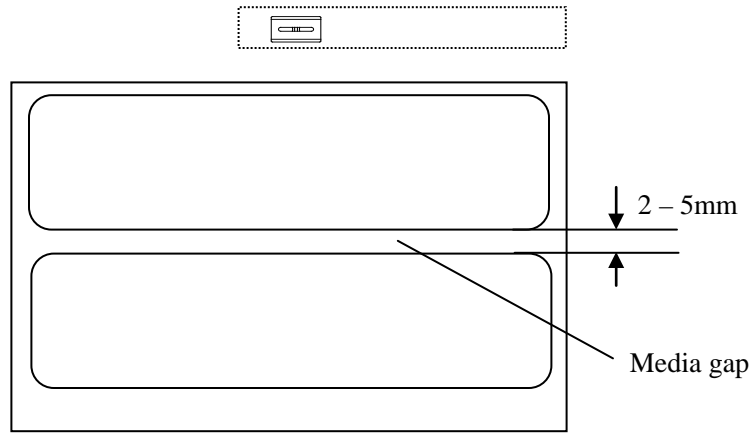
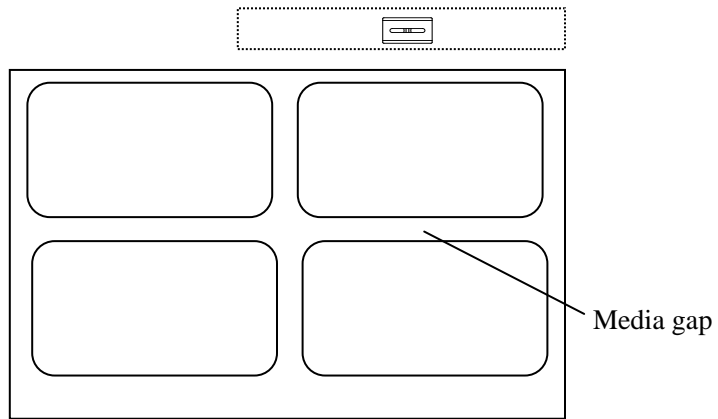


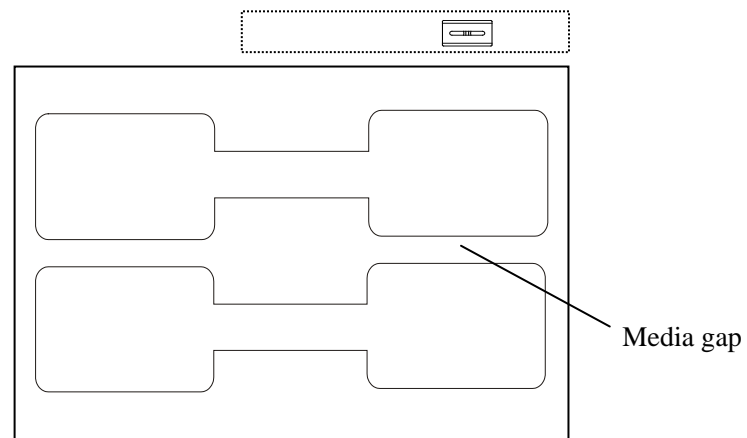
Figure 7-2



**Figure 7-3**



**Figure 7-4**



**Figure 7-5**



# Chapter 3: Operations and Settings

## Basic Operations

### Power Switch

The power switch is on the back panel of the printer. The symbols on the switch are defined as follows:

— — ON

○ — OFF

### The Front Panel

The Front Panel of the C168 Series printer consists of:

- Three Indicator Lamps: MEDIA, READY and RIBBON
- Three multi function buttons: PAUSE, FEED and CANCEL

### Indicator Lamps

The three lamps indicate the status of the printer (please refer to Chapter 4: Troubleshooting, for error indicators).

READY

- **Solid:** Indicates the printer is in the normal state.
- **Blinking:** Indicates the printer is in the 'PAUSE' state.

MEDIA

- **Solid:** Indicates the printer is in the normal state.
- **Blinking simultaneously with READY:** Running out of media.

RIBBON

- **Solid:** Indicates thermal transfer printing.
- **Off:** Direct thermal printing (no ribbon installed).
- **Blinking simultaneously with READY:** Running out of ribbon.

## Panel Buttons

The three buttons have different functions based on the mode of the operation is performed.

Mode	Basic Functions	Advanced Functions (see Advanced Functions below)
Feed/Calibration	Feed one label	Media Sensor Calibration
Pause/Self Test	<ul style="list-style-type: none"> <li>- Press once to pause current print job</li> <li>- Press a second time to resume printing</li> </ul>	Self-test: The printer performs a self-test and prints out a configuration report
Cancel/▶Reset	<ul style="list-style-type: none"> <li>- Cancel current batch of labels</li> <li>- Forces the printer to continue working after an error has been corrected</li> </ul>	Reset: Resets the printer to factory default settings

## Advanced Functions

### Media Sensor Calibration

It is necessary to accomplish Media Sensor Calibration after a new roll of media has been loaded.

1. Press and hold the Feed/Calibration button for about 4 seconds.
2. The printer will feed approximately 200mm of media.
3. The three indicators stop blinking and remain lit; the printer is back to a normal state.

### Self Test

1. Press and hold the Pause/Self Test button for about 4 seconds.
2. The printer will print out a configuration report and the 3 indicators will stop blinking and remain lit. The printer is back to a normal state.

The following information will be printed on the self-test report:

- Font list
- Hardware configuration and status
- DIP switch settings
- Label parameters
- Firmware version

## Reset – Reset the Printer to the Factory Default Settings

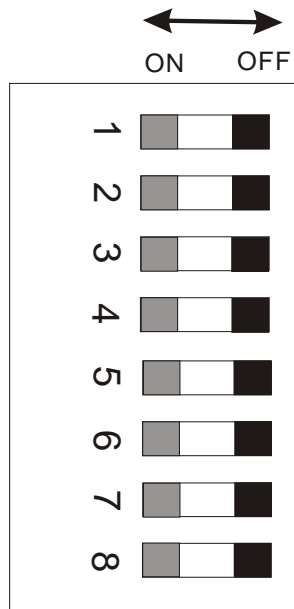
1. Press and hold the Cancel/▶Reset button for 4 seconds, the three lamps will blink simultaneously (the printer will return to normal state automatically if no operations are performed within 4 seconds).
2. Release and press the Cancel/▶Reset button again.
3. The three indicators stop blinking and remain lit. The printer is now in its normal state.

The following parameters have automatically been reset:

- Label
- Print darkness
- Speed
- Others

**Note:** The printed label count and printed length may not be reset.

## DIP Switch Panel



**Note:** Turn off printer before setting DIP switches.

DIP Bit	Functions	Remarks
1	ON: Direct thermal print OFF: Thermal transfer print	Printing type setting Default: OFF
2	ON: Tear off position OFF: Edge of next label	Stop position setting Default: OFF
3	ON: Cutter installed OFF: Cutter not installed	Cutter setting Default: OFF
4	ON: Peeler installed OFF: Peeler not installed	Peeler settings Default: OFF
5	Reserved and not available	/
6	ON: Enable IP setting OFF: Disable IP setting	IP address setup Default: OFF
7	$\overline{8} \quad \overline{7}$ 0   0 – 9600,n,8,1 0   1 – 19200,n,8,1	RS232 Serial Port baud rate setting 0: OFF, 1: ON Default: 00
8	1   0 – 38400,n,8,1 1   1 – 57600,n,8,1	

\* Please read the content in “[Important Notice](#)” section before setting your printer to direct thermal mode.

## Windows Driver

The C168 Series printer driver is packaged with the C168 in the CD-ROM pack, and is compatible with the following operating systems:

- Windows 8
- Windows Vista
- Windows XP
- Windows 7
- Windows NT
- Windows 2003
- Windows 2000
- Windows 98
- Windows ME

Drivers can also be downloaded from [www.postek.com.cn](http://www.postek.com.cn) and [www.postektechnologies.com](http://www.postektechnologies.com)

**Note:** Before updating a driver, always first remove the old version(s) that may be loaded on your computer.

## Label Software

Each C168 Series printer is packaged with powerful barcode label editing software.

**Note:** Before downloading the software, always first remove any old version that may be loaded on your computer.

# Chapter 4: Maintenance

## Warnings:

- (1) Make sure the printer is powered off before performing maintenance operations.
- (2) The Printhead may be hot due to recent printing. Wait until the Printhead cools before performing maintenance.
- (3) Use only anhydrous isopropyl alcohol to clean the print head.

## Cleaning the Printhead

The Printhead is the mechanism that enables the ink to impact the label. Due to the Printhead's precision construction and necessary location in the printer, it comes into contact with consumables and therefore is susceptible to dirt accumulation. If dirt is not removed, the Printhead may be damaged. To ensure longevity of the Printhead, follow the recommended maintenance guidelines below:

**Note:** A Printhead damaged by misuse is not covered under warranty.

1. Clean the Printhead
2. Clean the Printhead after every (1) roll of ribbon use or every (3) rolls of label media use. To clean the Printhead:
3. Turn printer power off
4. Open the top cover of C168 Series printer
5. Turn the handle to open.
6. Remove the ribbon (if applicable) and media
7. Use a cotton swab dipped in anhydrous isopropyl alcohol. Rub the swab along the Printhead until the swab no longer accumulates ink
8. Let the Printhead dry before using the printer again

## Cleaning the Platen Roller

The Platen Roller, located at the exit point and underneath labels, supports the labels as they feed out of the printer. The roller can accumulate debris from consumables, such as dirt, sand, dust or glue. To ensure longevity of the Platen Roller, follow the recommended maintenance guidelines below:

Clean the Platen Roller after every (3) rolls of label media used. To clean the Platen Roller:

1. Turn off the printer.
2. Open the top cover.
3. Release and lift the Printhead Module
4. Remove the ribbon (if applicable) and media.
5. Use a cotton swab dipped in anhydrous isopropyl alcohol. Rub the swab along the Platen Roller while rotating the roller until the swab no longer accumulates ink or debris.

## Cleaning the Printer Interior

Over time, the printer's interior may collect dust or debris from the consumables. It is advised to periodically clean the printer's interior in order to prevent the accumulated debris from damaging internal parts.

To clean the printer interior, use a cotton swabs dipped into anhydrous isopropyl alcohol and remove any debris.

# Chapter 5: Troubleshooting

Occasionally situations occur that require some troubleshooting. Possible issues and potential solutions are listed in this section. While not every situation is addressed, you may find some of these tips useful.

## Error Indications

Typically, when the printer is not functioning, one or two of the three indicator lamps will begin blinking. The possible situations addressed by the status of the three indicator lamps are listed below.

### READY and MEDIA Lamps blink simultaneously:

Possible Cause	Recommended Solutions
Media sensor cannot detect labels	a) Check and confirm the media has been loaded correctly b) Check the position of the media sensor and confirm it could detect the media gap or black line c) Calibrate the media sensor <b>Note:</b> If using continuous media, ensure correct Media Type settings in chosen in the label software
Media ran out	Load a roll of media
Media jammed	Clear the jam
The Media Roll Guides are not firmly positioned against the Media or have not been installed.	Install the Media Roll Guides correctly and press them firmly against the media.
Media sensor is broken	Contact an authorized POSTEK service provider for technical support.

### READY and RIBBON Lamps blink simultaneously:

Possible Cause	Recommend Solutions
Ribbon ran out	Load a new roll of ribbon
Ribbon jammed	Clear the jam
Ribbon Sensor error	Contact an authorized POSTEK service provider for technical support.

### Only READY Lamp blinks:

Possible Cause	Recommend Solutions
Serial I/O error	Check DIP switches for the baud rate settings
Memory overflow	a) Restart the printer b) Reset the printer

## Miscellaneous

### Vertical Blank Lines Appear

If the printer prints vertical blank lines as shown in the below picture, it may be due to a dirty or defective Printhead. See the table below for possible causes and solutions.



Cause	Corrective Action
The Printhead is dirty.	Clean the Printhead. Follow the recommended maintenance guidelines for cleaning the Printhead.
Vertical lines still appear after cleaning the Printhead.	Contact an authorized POSTEK service provider for technical support.

### Printer Timeout Error Message

Execute following corrective actions:

1. Check the interface cable for proper connection.
2. Ensure the printer is powered on.

If the trouble still exists, please contact an authorized POSTEK service provider for technical support.

### Data Sent but Not Printing

1. Ensure the correct driver is chosen in the label software.
2. Reset the printer.

If the trouble still exists, please contact an authorized POSTEK service provider for technical support.



## Poor Printing Quality

When experiencing poor print quality, check the following:

1. Adjust print darkness setting value.
2. Adjust print speed setting value.
3. Clean the Printhead and the platen roller.
4. Poor quality printing may be caused from using a low quality ribbon. Change to higher quality ribbon.
5. Poor quality printing may be caused from using low quality media. Change to higher quality media.

## Recovery

After the miscellaneous has been cleared, press the CANCEL button to clear the alarm or restart the printer to resume the printing automatically.

**Note:** For errors not listed here, please contact an authorized POSTEK Service Provider for further assistance.

# Appendix A: Interface Specifications

The RS232 connector on the printer is a DB9F:

Pin	Direction	Definition
1	/	/
2	Out	TX
3	In	RX
4	In	CTS
5	-	Ground
6	Out	RTS
7	In	DSR
8	Out	DTR
9	/	/

**Connection with host:**

Host 25S	Printer 9P	Host 9S	Printer 9P
TX 2	..... 3 RX	RX 2	..... 2 TX
RX 3	..... 2 TX	TX 3	..... 3 RX
DSR 6	..... 8 DTR	DTR 4	..... 7 DSR
DTR 20	..... 7 DSR	DSR 6	..... 8 DTR
RTS 4	..... 4 CTS	RTS 7	..... 4 CTS
CTS 5	..... 6 RTS	CTS 8	..... 6 RTS
GND 7	..... 5 GND	GND 5	..... 5 GND

Alternately you can just connect the 3 wires as follows:

Host 25S	Printer 9P	Host 9S	Printer 9P
TX 2	..... 3 RX	RX 2	..... 2 TX
RX 3	..... 2 TX	TX 3	..... 3 RX
GND 7	..... 5 GND	GND 5	..... 5 GND
pin 4	□	pin 4	□
pin 5	□	pin 6	□
pin 6	□	pin 7	□
pin 20	□	pin 8	□

- Baud rate: 9600, 19200, 38400, 57600
- Data format: always 8 data bits, 1 start bit and 1 stop bit.
- Parity: always non parity.
- Flow control: RTS/CTS (Hardware flow control).  
If you are using software or drivers under the Windows environment, the flow control must be set to “hardware.”
- Any communications port can transmit data from the host (RS232, Ethernet, or USB). Preliminary communications settings are not required since the printer will automatically detect which port is active.

**Note:** Never send data from 2 ports at the same time. Data cannot be sent to more than one port simultaneously or data corruption and print errors may occur.

## Appendix B: ASCII Table

	0	1	2	3	4	5	6	7
0	NUL			0	@	P	`	p
1	SOH	XON	!	1	A	Q	a	q
2	STX		“	2	B	R	b	r
3		XOFF	#	3	C	S	c	s
4			\$	4	D	T	d	t
5		NAK	%	5	E	U	e	u
6	ACK		&	6	F	V	f	v
7	BEL		‘	7	G	W	g	w
8	BS		(	8	H	X	h	x
9			)	9	I	Y	i	y
A	LF		*	:	J	Z	j	z
B		ESC	+	;	K	[	k	{
C	FF		,	<	L	\	l	
D	CR		-	=	M	]	m	}
E	SO	RS	.	>	N	^	n	~
F	SI	US	/	?	O	_	o	DEL

**Note:** The €sign is included in the embedded table at DEC128 or HEX 80

