

User's Guide
Model 32 & 32B
Cryogenic Temperature Controller

CRYOGENIC CONTROL SYSTEMS, INC.

P.O. Box 7012
Rancho Santa Fe, CA 92067
Tel: (858) 756-3900
Fax: (858) 759-3515
www.cryocon.com

© Copyright 2008 - 2011
Cryogenic Control Systems, Inc.
All Rights Reserved.

Printing History

Edition 6f, April 1, 2011

Certification

Cryogenic Control Systems, Inc. (Cryo-con) certifies that this product met its published specifications at the time of shipment. Cryo-con further certifies that its calibration measurements are traceable to the United States National Institute of Standards and Technology (NIST).

Warranty

This product is warranted against defects in materials and workmanship for a period of one year from date of shipment. During this period Cryo-con will, at its option, either repair or replace products which prove to be defective.

For products returned to Cryo-con for warranty service, the Buyer shall prepay shipping charges and Cryo-con shall pay shipping charges to return the product to the Buyer.

However, the Buyer shall pay all shipping charges, duties, and taxes for products returned to Cryo-con from another country.

Warranty Service

For warranty service or repair, this product must be returned to a service facility designated by Cryo-con.

Limitation of Warranty

The foregoing warranty shall not apply to defects resulting from improper or inadequate maintenance by the Buyer, Buyer supplied products or interfacing, unauthorized modification or misuse, operation outside of the environmental specifications for the product, or improper site preparation or maintenance.

The design and implementation of any circuit on this product is the sole responsibility of the Buyer. Cryo-con does not warrant the Buyer's circuitry or malfunctions of this product that result from the Buyer's circuitry.

In addition Cryo-con does not warrant any damage that occurs as a result of the Buyer's circuit or any defects that result from Buyer-supplied products.

Notice

Information contained in this document is subject to change without notice.

Cryo-con makes no warranty of any kind with regard to this material, including, but not limited to, the implied warranties of merchantability and fitness for a particular purpose.

Cryo-con shall not be liable for errors contained herein or for incidental or consequential damages in connection with the furnishing, performance, or use of this material. No part of this document may be photocopied, reproduced, electronically transferred, or translated to another language without prior written consent.

Trademark Acknowledgement

CalGen® and Cryo-Con® are registered trademarks of Cryogenic Control Systems, Inc. All other product and company names are trademarks or trade names of their respective companies.

Safety

The Model 32 does not contain any user serviceable parts. Do not open the enclosure. Do not install substitute parts or perform any unauthorized modification to the product. For service or repair, return the product to Cryo-con or an authorized service center.

Table of Contents

Preparing the controller for use.....	1
Supplied Items.....	1
Verify the AC Power Line Voltage Selection.....	1
Apply Power to the Controller.....	1
Installation.....	3
Initial Setup and Configuration.....	4
Options and Accessories.....	7
Returning Equipment.....	9
A Quick Start Guide.....	11
A Quick Start Guide to the User Interface.....	11
Front Panel Operation.....	17
The Keypad.....	17
The VFD Display.....	22
Front Panel Menu Operation.....	27
Instrument Setup Menus.....	27
Specifications, Features and Functions.....	51
Specification Summary.....	51
Input Channels.....	55
Control Outputs.....	64
Remote Interfaces.....	67
Rear Panel Connections.....	68
Mechanical, Form Factors and Environmental.....	74
Basic Setup and Operating Procedures.....	77
Configuring a sensor.....	77
Adding a New Sensor Type.....	77
Autotuning.....	80
Temperature Ramping.....	85
Cryocooler Signature Subtraction.....	87
Using an external power booster.....	90
Using Thermocouple Sensors.....	92
CalGen™ Calibration Curve Generator.....	96
System Shielding and Grounding Issues.....	101
Grounding Scheme.....	101

Cryo-con Utility Software.....	103
Installing the Utility Software.....	103
Connecting to an Instrument.....	104
Using the Interactive Terminal.....	105
Downloading or Uploading a Sensor Calibration Curve.....	106
Using the Real-Time Strip Charts.....	110
Data Logging.....	111
Remote I/O command HELP.....	113
CalGen Calibration Curve Generator.....	114
The Vapor Pressure Calculator.....	117
Downloading Instrument Firmware	118
Instrument Calibration.....	123
Cryo-con Calibration Services.....	123
Calibration Interval.....	123
Minimum Required Equipment.....	124
The Basic Calibration Sequence.....	124
Calibration of Silicon Diodes.....	129
Calibration of DC resistors.....	130
Calibration of AC resistors.....	130
Remote Operation.....	131
Remote Interface Configuration.....	131
Introduction to Remote Programming.....	133
SCPI Status Registers.....	134
Remote Commands.....	137
Remote Command Summary.....	203
EU Declaration of Conformity.....	211
Appendix A: Installed Curves.....	213
Factory Installed Curves.....	213
Sensor Curves on CD.....	215
Appendix B: Troubleshooting Guide.....	217
Error Displays.....	217
Control Loop and Heater Problems.....	218
Temperature Measurement Errors.....	220
Remote I/O problems.....	221
General problems.....	222
Appendix C: Application Note on Signal Dither.....	223
Using Dither in Digital Control Loops.....	223
Appendix D: Tuning Control Loops.....	227
Introduction.....	227
Various methods for obtaining PID coefficients.....	227
Manual Tuning Procedures.....	228
Appendix E: Sensor Calibration Curve Tables.....	231
Cryocon S700 Silicon Diode.....	231

Index of Tables

Table 1: Model 32 Instrument Accessories.....	7
Table 2: Cryogenic Accessories.....	8
Table 3: Input Sensor Selections.....	12
Table 4: Loop #1 Output Summary.....	13
Table 5: Control Type Summary.....	14
Table 6: Keypad key functions.....	21
Table 7: Temperature Units.....	24
Table 8: Display Configurations.....	29
Table 9: Input Channel Setup Menus.....	31
Table 10: Control Loop Setup Menus.....	34
Table 11: User Configurations Menu.....	39
Table 12: System Functions Menu.....	41
Table 13: PID table Menu.....	45
Table 14: PID Table Edit Menu.....	46
Table 15: Sensor Setup Menu.....	47
Table 16: Calibration Curve Menu.....	49
Table 17: Voltage Bias Selections.....	56
Table 18: NTC Resistor Measurement Accuracy.....	56
Table 19: Supported Sensor Configurations.....	57
Table 20: PTC Resistor Sensor Configuration.....	58
Table 21: NTC Resistor Sensor Configuration.....	58
Table 22: Sensor Performance for Diodes and Pt Sensors.....	60
Table 23: Sensor Performance for NTC sensors.....	61
Table 24: Sensor Performance for Thermocouple Sensors.....	62
Table 25: Loop 1 Heater output ranges.....	64
Table 26: AC Power Line Fuses.....	69
Table 27: Input Connector Pin-out.....	70
Table 28: Dual Sensor Cable Color Codes.....	71
Table 29: Thermocouple Types.....	73
Table 30: RS-232 DB-9 Connector Pinout.....	73
Table 31: Sensor Setup Menu.....	78
Table 32: Autotune Menu.....	83
Table 33: First CalGen™ Menu, Diode Sensor.....	97
Table 34: CalGen™ Menu, 2-point Diode Sensor.....	98
Table 35: CalGen™ New Curve Menu.....	99
Table 36: Recommended GPIB Host Setup Parameters.....	131
Table 37: Remote Command Summary.....	209
Table 38: Factory Installed Sensors.....	213
Table 39: S700 Cable Color Codes.....	232

Index of Figures

Figure 1: Rack Mount Kit.....	3
Figure 2: Model 32 Front Panel Layout.....	17
Figure 3: Model 32 Rear Panel Layout.....	68
Figure 4: Proper Assembly of the Input Connector	70
Figure 5: Diode and Resistor Sensor Connections.....	71
Figure 6: Thermocouple Input Connector.....	72
Figure 7: RS-232 Null Modem Cable.....	74
Figure 8: Instrument Calibration Screen.....	125

Preparing the controller for use.

The following steps help you verify that the controller is ready for use.

Supplied Items.

Verify that you have received the following items with your controller. If anything is missing, contact Cryogenic Control Systems, Inc. directly.

- Model 32/32B Cryogenic Temperature Controller.
- User's Manual (PN 3038-029).
- Cryo-con software CD (PN 4034-029).
- Connector kit (PN 4038-015) consisting of:
 - Two DIN-5 input connectors (PN 04-0436)
 - A Dual banana plug heater connector (PN 04-0433)
 - A Terminal block plug Loop 2 connector (PN 04-0301).
- Detachable 120VAC Line Cord (04-0310).
- Certificate of Calibration.

Verify the AC Power Line Voltage Selection.

The AC power line voltage is set to the proper value for your country when the controller is shipped from the factory. Change the voltage setting if it is not correct. The settings are: 100, 120 220, or 240 VAC. For 230 VAC operation, use the 220 VAC setting.

On the rear panel of the instrument, the AC voltage selection can be seen on the power entry module. If the setting is incorrect, please refer to section [Fuse Replacement and Voltage Selection](#) to change it.

Apply Power to the Controller

Connect the power cord and turn the controller on by pressing the **Power** key for a minimum of 0.5 Seconds. The front panel will show a Power Up display with the model number and firmware revision.

While the Power Up display is shown, the controller is performing a self-test procedure that verifies the proper function of internal data

and program memories, remote interfaces and input/output channels. If an error is detected during this process, the controller will freeze operation with an error message display. In this case, turn the unit off and refer to [Appendix B: Troubleshooting Guide](#).

**Cryo-con Model 32B
Firmware Rev. 6.04H**



Caution: Do not remove the instrument's cover or attempt to repair the controller. There are no user serviceable parts, jumpers or switches inside the unit. Further, there are no software ROM chips, trim pots, batteries or battery-backed memories. All firmware installation and instrument calibration functions are performed externally via the remote interfaces.

After about five seconds, the self-test will complete and the controller will begin normal operation.

Installation

General

The Model 32 can be used as a bench top instrument, or mounted in an equipment rack. In either case, it is important to ensure that adequate ventilation is provided.

Cooling airflow enters through the side holes and exhausts out the fan on the rear panel. It is important to allow at least $\frac{1}{2}$ " of clearance on the left and right sides and to ensure that the exhaust path of the fan is not blocked.

Rack Mounting

You can rack mount the controller in a standard 19-inch rack cabinet using the optional rack mount kit. Instructions and mounting hardware are included with the kit.

4034-032 Single instrument shelf rack mount kit.

4034-031 Dual instrument shelf rack mount kit.

Since the controller is an industry standard size, you can mount any similar size instrument next to it in the rack.

Note that the rack mount extends the height of the controller from 2U ($3\frac{1}{2}$ "") to 3U ($5\frac{1}{4}$ "").

To mount the controller, first remove the plastic feet and instrument bail on the bottom of the unit.

Next, lay the controller on the shelf and slide forward to line up with the front cutout.

Use four #6- $\frac{1}{4}$ " screws to secure the controller using the same threaded holes as the plastic feet used.

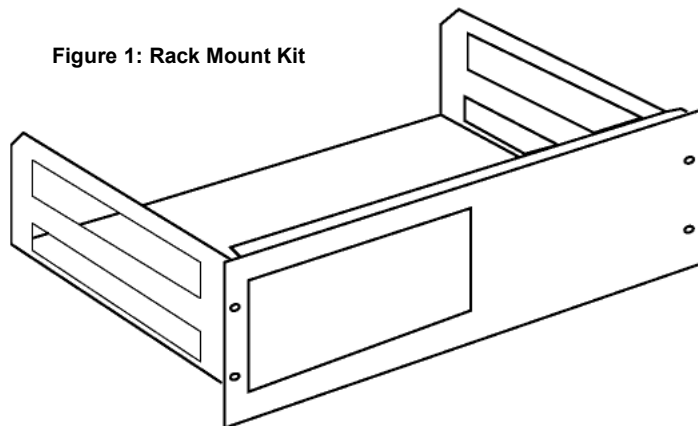

Figure 1: Rack Mount Kit



Warning: When rack mounting, do not use screws that protrude into the bottom of instrument more than $\frac{1}{4}$ ". Otherwise, they can touch internal circuitry and damage it.

Initial Setup and Configuration

Before attempting to control temperature, the following instrument parameters should be checked:

1. The Loop #1 Heater resistance setting should match the actual heater resistance that you are going to use. Choices are 50 Ω and 25 Ω . A heater resistance of less than 25 Ω should use the 25 Ω setting. Using the 50 Ω setting with a heater resistance much less than 50 Ω may cause the instrument to overheat and disengage the control loops.

Set the heater resistance by pressing the **Loop 1** key and refer to the [Control Loop Setup menu](#) section.

2. The Loop #1 heater range should be set to a range where the maximum output power will not damage your equipment. To set this parameter, press the **Loop 1** key and refer to the [Control Loop Setup menu](#) section.
3. The controller has an over-temperature disconnect feature that monitors a selected input and will disconnect both control loops if the specified temperature is exceeded. This feature should be enabled in order to protect your equipment from being over heated. To enable, press the **Sys** key and refer to the [System Functions Menu](#) section.

Factory Default Setup

A controller with factory default settings will have an operational display like the one shown here. The dash (-) or dot (.) characters indicate that there is no sensor connected.

<p>A - - - - - K E K 1 - Off - Hi 2 - Off - 10W</p>
--

Note that, in some cases, there will be an erratic temperature display when no sensor is connected. This is not an error condition. The high input impedance of the controller's input preamplifier causes erratic voltage values when unconnected.

Input Channel factory defaults are:

- Sensor Units: Kelvin.
- Sensor Type: LS DT-670 (Lakeshore DT-670 Curve 11 Silicon Diode)
- Bias Type: DC
- Alarm Enables: Off

To change these, press the **ChA** or **ChB** key and refer to the [Input Channel Setup Menu](#) section.

Control Loop factory defaults are:

- Setpoint: 100K
- P gain: 5.0, I gain: 28.0 Seconds, D gain: 8.0, Manual output power, Pman: 5%
- Control input channel: A for Loop 1, B for Loop 2
- Loop 1 Range: Low
- Control Type: Manual
- Heater Resistance: 25Ω

To change these, press the **Loop 1** or **Loop 2** key and refer to the [Control Loop Setup menu](#) section.

Instrument setup factory defaults are:

- Display Filter Time Constant: 2.0 Seconds. Display Resolution: 3 digits.
- Over Temperature Disconnect: Off
- Remote Interface: RS-232, RS-232 Baud Rate: 9600.
- IEEE-488 (GPIB) Address: 12
- AC Power Line Frequency: 60Hz
- Cryocooler Filter: Off
- Control on power-up: OFF

To change these, press the **Sys** key and refer to the [System Functions Menu](#) section.

<p> NOTE: Factory defaults may be restored at any time by use of the following sequence: 1) Turn power to the Model 32 OFF. 2) Press and hold the Enter key while turning power back ON.</p>

Model Identification

The model number of all Cryo-con controllers is identified on the front and rear panel of the instrument as well as in various instrument displays.

Model 32 – Basic controller with two standard input channels. Outputs are Loop #1: 50Watt 3-range linear heater and Loop 2: 0-5Volt analog output.

Model 32B – Controller with two standard input channels. Outputs are Loop 1: 50Watt 3-range linear heater and Loop 2: Ten Watt linear heater.

The only option that can be ordered with a Model 32 or 32B is a single thermocouple input for sensor 'B'. These variations are:

Model 32B-T Model 32B with one standard input plus one universal thermocouple input.

Model 32-T Model 32 with one standard input plus one universal thermocouple input.

Ordering Information

Standard	Model 32B	Description
Model 32	Model 32B	Controller with two standard multi-function sensor input channels.
Model 32-T	Model 32B-T	Controller with one standard input and one universal thermocouple input.

Technical Assistance.

Trouble shooting guides and user's manuals are available on our web page at <http://www.cryocon.com>.

Technical assistance may be also be obtained by contacting Cryo-con as follows:

Cryogenic Control Systems, Inc.
PO Box 7012
Rancho Santa Fe, CA 92067

Telephone: (858) 756-3900x100 FAX: (858) 759-3515
e-mail: techsupport@cryocon.com

For updates to LabVIEW™ drivers, Cryo-con utility software and product documentation, go to our web site and select the Download area.

Current Firmware Revision Level

As of December, 2006 the current firmware revision level for the Model 32 series is 6.10.

Current Hardware Revision Level

As of December, 2006, the current hardware revision level for the Model 32 series is H. Hardware cannot be upgraded in the field.

Options and Accessories**Instrument Accessories**

Cryo-con Part #	Description
4034-031	Two instrument shelf rack mount kit
4034-032	One instrument shelf rack mount kit
04-0420	RS-232 Null Modem Cable, 6'. (Required for downloading firmware to the instrument products)
4034-035	Shielded IEEE-488.2 Interface Bus Cable, 6'6"
4039-010	Cable Assembly, 10 Pin to Modular Test Dewar
4039-009	Cable Assembly, 19 Pin to Modular Test Dewar
04-0310	AC Power Cord
4038-036	Loop 1 / Loop 2 connector kit
4038-033	Din-5 Sensor Input Connector
3038-029	Additional User's Manual/CD

Table 1: Model 32 Instrument Accessories

Cryogenic Accessories

Cryo-con Part #	Description
S700	S700 series Silicon Diode Temperature Sensors. Temperature range: 1.4 to 495K
CP-100	CP-100 series Ceramic Wound RTD, 100Ω
GP-100	GP-100 series Glass Wound RTD, 100Ω
CPX-100	CPX-100 series Thin Film Platinum RTD, 100Ω
CPX-1K	CPX-1K series Thin Film Platinum RTD, 1,000Ω
3039-015	Cartridge Heater, Silicon free, 25Ω / 25 Watt, 1/4" x 1 1/8". Temperature range to 1,600K
3039-016	Cartridge Heater, Silicon free, 50Ω / 50 Watt, 1/4" x 1 1/8". Temperature range to 1,600K
4039-011	Pre-cut Nichrome wire heater w/connectors, 25Ω
4039-012	Pre-cut Nichrome wire heater w/connectors, 50Ω
4039-013	Pre-cut Nichrome wire heater w/connectors, Custom. Specify length or resistance.
3039-006	Bulk Nichrome Heater Wire, 32AWG, Polyamide insulation, 100'

Table 2: Cryogenic Accessories

Returning Equipment

If an instrument must be returned to Cryo-con for repair or recalibration, a Return Material Authorization (RMA) number must first be obtained from the factory. This may be done by Telephone, FAX or e-mail.

When requesting an RMA, please provide the following information:

1. Instrument model and serial number.
2. User contact information.
3. Return shipping address.
4. If the return is for service, please provide a description of the malfunction.

If possible, the original packing material should be retained for reshipment. If not available, consult factory for packing assistance.

Cryo-con's shipping address is:

Cryogenic Control Systems, Inc.
17279 La Brisa Street
Rancho Santa Fe, CA 92067

A Quick Start Guide

A Quick Start Guide to the User Interface.

Pressing the **Power** key will toggle the controller's AC power on and off. This key must be pressed and held for two seconds before power will toggle.

Pressing the **Stop** key will immediately disengage both control loops. Pressing the **Control** key will engage them.

The Home Status Display

Pressing the **Home** key will return the screen to the Home Display from anywhere in the sub-menus. The Home Display is the primary display for instrument status information.

Several Home Displays are available so that the user can see desired information without additional clutter. To scroll through the available displays, press the ▲ or ▼ key.

Accessing the heater setpoint

To instantly access the setpoint for either control loop, press the **Set Pt** key.

Configuring a temperature sensor

Configuring an input sensor from the front panel is performed by using the Input Channel Setup Menu. To access this menu for input A, press the **ChA** key, or for input B, the **ChB** key.

The first line of this menu is used to change the sensor units. It shows the selected input channel, the current temperature (in real time) and the current units. An example is shown here.



To change the sensor units, use the right and left arrow keys (▶ or ◀) to scroll through the available options. When the desired units are shown, press the **Enter** key to make the selection. The display will now show the current temperature with the new units.

Next, go to the sensor selection field by pressing the down arrow (▼) key. This field is used to select the actual sensor type. In the



example shown here, the input channel is currently configured for a standard Platinum 100 sensor. Use the right and left arrow keys (▶ or ◀) to scroll through the available options. When the desired sensor is shown, press the **Enter** key to make the selection. A summary of sensor selections is shown here:

Sensor	Description
None	Input disabled
Cryocon S700	Cryo-con S700 series Silicon Diode. Range: 1.4 to 495K.
LS DT-670	Lakeshore Silicon Diode Curve 11 for DT-670 series diodes. Range: 1.4 to 500K.
LS DT-470	Lakeshore Silicon Diode Curve 10 for DT470 series diodes. Range: 1.4 to 495K.
CD-12A Diode	Cryo Industries CD-12A Silicon Diode. Range: 1.4 to 325K.
SI 410 Diode	Scientific Instruments, Inc. 410 Diode Curve. Range: 1.5 to 450K..
Pt100 385	DIN43760 standard 100Ω Platinum RTD. Range: 23 to 1023K, 1mA excitation.
Pt1K 385	1000Ω at 0°C Platinum RTD using DIN43760 standard calibration curve. Range: 23 to 1023K.
Pt10K 385	10KΩ at 0°C Platinum RTD. Temperature coefficient 0.00385, Range: 23 to 475K.
RhFe 27, 1mA	Rhodium-Iron resistor, 27 Ohms at 0°C. 1mA DC excitation.
RO-105 AC	Scientific Instruments Inc. RO-105 Ruthenium Oxide sensor with constant-voltage AC excitation.
RO-105 DC 10μA	Scientific Instruments Inc. RO-105 Ruthenium Oxide sensor with constant-current 10μA DC excitation.
RO-600 AC	Scientific Instruments Inc. RO-600 Ruthenium Oxide sensor with constant-voltage AC excitation. .
User Sensor 1	User supplied sensor #1.
User Sensor 2	User supplied sensor #2.
User Sensor 3	User supplied sensor #3.
User Sensor 4	User supplied sensor #4.

Table 3: Input Sensor Selections.

Before one of the user-supplied sensors can be used, the sensor’s calibration curve and configuration data must be installed. This is best done by using Cryo-con’s utility software.

This completes the process of configuring an input channel. Press the **Home** key to return to the Home Status display.

Configuring the Loop #1 Output

Before using the Loop #1 (main heater) control output, it is essential that the proper load resistance and output range be selected. This is done using the Control Loop Setup menu as follows:

- ❑ Press the **Loop 1** key to go to the Control Loop Setup menu for Loop #1.
- ❑ Use the up arrow and down arrow keys (▲ and ▼) to scroll to the Htr Resistance field. An example is shown here:



- Use the left and right arrow keys (**▶** or **◀**) to select between a 50 Ohm and a 25 Ohm heater and then press the **Enter** key.
- Use the up arrow and down arrow keys (**▲** and **▼**) to scroll to the Range field and then select Hi, Mid or Low. Be sure to select a range that does not exceed the ratings of your cryostat. A summary of full-scale output power for the various ranges is given here:

1 Range : HI ▶

Range	Max. Output Power	
	25Ω	50Ω
Hi	25 Watts	50 Watts
Mid	2.5 Watts	5.0 Watts
Low	0.25 Watts	0.50 Watts

Table 4: Loop #1 Output Summary

Next, the control type should be set by scrolling to the Type field and selecting the desired loop operating mode.

1 Type : PID ▶

A summary of control types is given here:

Type	Description
Off	Control loop is disabled.
Man	Manual control mode. Here, a constant heater output power is applied. The Pman field selects the output power as a percentage of full-scale.
Table	PID control mode where the PID coefficients are generated from a stored, user supplied PID table.
PID	Standard PID control.
RampP	Temperature ramp control. Uses PID control to perform a temperature ramp.

Table 5: Control Type Summary



Caution: The Model 32 has an automatic control-on-power-up feature. If enabled, the controller will automatically begin controlling temperature whenever AC power is applied. For a complete description of this function, please see the SYS-Auto Ctl function in the [System Functions menu](#) section.

Configuring the Loop #2 Output

The second control loop of a Model 32B controller is a fixed 10 Watt output that is matched to a 50 Ω resistive load. Therefore, there are no load resistance or range settings to configure.

On the standard Model 32, the second control loop is a zero to 10 Volt output that is intended to drive a booster supply or other voltage controlled device. It is not a heater output.

All other configuration settings are identical for both Loop #1 and Loop #2.



Caution: The Model 32 has an automatic control-on-power-up feature. If enabled, the controller will automatically begin controlling temperature whenever AC power is applied. For a complete description of this function, please see the SYS-Auto Ctl function in the **System Functions menu** section.

Restoring Factory Defaults

Factory default settings may be restored with the following simple procedure:

1. Turn AC power OFF.
2. Press and hold the Enter key while turning AC power back ON. Keep the key pressed until you see the power-up display indicating that defaults have been restored.

 **NOTE:** Factory defaults may be restored at any time by use of the following sequence: 1) Turn power to the Model 32 OFF. 2) Press and hold the **Enter** key while turning power back ON.

Forcing a Firmware Download

The Model 32 may be powered up in a mode where it will wait for a firmware update via the serial port. This is not normally necessary because the Cryo-con utility software will set this mode when a firmware update is being processed. However, if the instrument has crashed during a firmware download or has otherwise become corrupted, following this procedure will set the firmware download mode:

1. Turn AC power OFF.
2. Press and hold the STOP key while turning the AC power back ON. Keep the key pressed until the firmware download display is seen. The initial firmware download screen is shown here.
3. Use the Utility Software package to download new firmware over the RS-232 port. Instructions are detailed in the section: "[Downloading Instrument Firmware](#)"

Record 000 of 502 Errors: 000
--

Front Panel Operation

The user interface of the Model 32 Cryogenic Temperature Controller consists of a two line by 20 character Vacuum Florescent display and a keypad. All features and functions of the instrument are accessed via this simple and intuitive menu-driven interface.

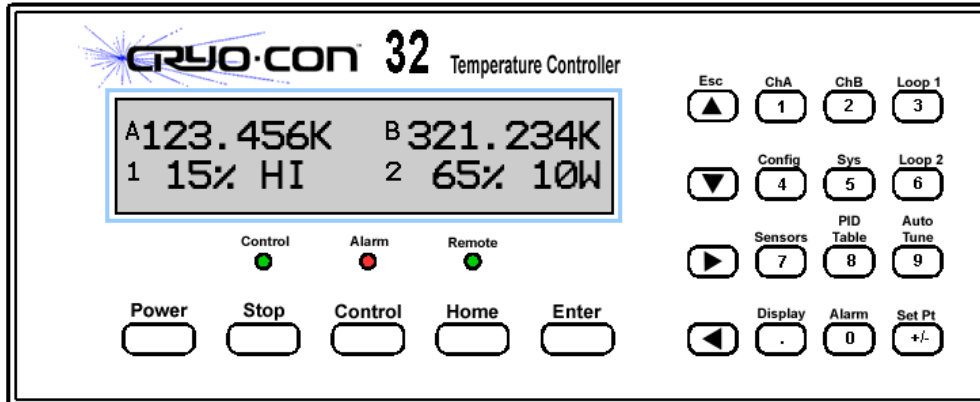

Figure 2: Model 32 Front Panel Layout

The Keypad

Function Keys

The Function Keys on the Model 32 are **Power** , **Stop** , **Control** , **Home** , and **Enter** as shown here:



The **Power** key is used to turn AC power to the controller on or off. Note that this key must be pressed and held for one second in order to toggle AC power.

Note: The Model 32 uses a smart power on/off scheme. When the power button on the front panel is pressed to turn the unit off, the instrument's configuration is copied to flash memory and restored on the next power up. If the front panel button is not used to toggle power to the instrument, the user should configure the controller and cycle power from the front panel button one time. This will ensure that the proper setup is restored when AC power is applied.

The **Stop** and **Control** keys are used to disengage or engage the instrument's output control loops. Pressing **Control** will immediately turn on all enabled heater outputs and pressing **Stop** will turn them both off. To enable or disable an individual loop, go to the [Control Loop Setup](#) menu and select the desired 'Type'.

The **Home** key is used to take the display to one of the Home Status displays. These displays show the full status of the instrument.

Generally, pressing the **Home** will take the display up one level in the Setup Menu tree and the Home Status displays are at the root level.

The **Enter** key is functional only in the Setup Menus and is used to enter numeric data or make a selection.

Navigation Keys



Navigation through the displays and menus of the Model 32 is accomplished with the cursor keys ▲ and ▼.

The ▲ and ▼ keys are used to scroll the display up or down through all of the lines available on a given menu.

When the display is showing one of the Home Status displays, the ▲ and ▼ keys are used to scroll through the four available display formats. When the display is in any of the Setup menus, these keys are used to scroll through the various lines of the menu.

The Keypad and Setup Menu Keys

The keypad keys on the far right side of the instrument serve a dual function. When numeric data is required, these keys are used as a standard keypad where the numbers are printed on the keys. Otherwise, they are used to go directly to the Setup Menu printed over the top of the key.

When used as Setup Menu keys, their function is identified by a label printed just above the key and is as follows:

ChA -Go to the Input [Channel A setup menu](#).

ChB -Go to the Input [Channel B setup menu](#).

Loop 1 -Go to the Loop 1, or primary heater output, setup menu.

Loop 2 - Go to the Loop 2, or secondary heater output, setup menu.

Auto Tune - Go to the [auto-tuning menu](#) for either loop.

Config -Go to the [User Configurations menu](#).

Sensors - Go to the [Sensors configuration menu](#), including sensor calibration curves.

PID Table - Go to the [PID tables setup menu](#).

Sys - Go to the [System Functions menu](#). This includes fields for Remote Input / Output, Display filters and the Over Temperature Disconnect feature.

Display - Go to the Display setup menu. This allows configuration of the front panel display from a list of options

Alarm - Go to the Alarm Status menu.

Set Pt - Set the setpoint values for both control loops.

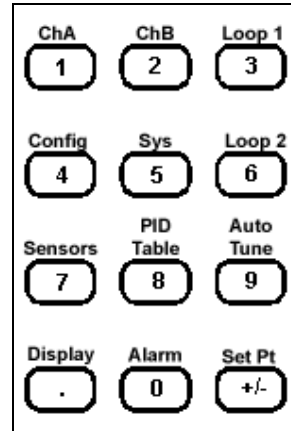





The Selection Keys and Enumeration Fields

Enumeration fields are display fields where the value is one of several specific choices. For example, the Heater Range field in the Loop 1 setup menu may contain one of only three possible values: HIGH, MID and LOW. There are many enumeration fields that contain only the values ON and OFF.

An enumeration field is always indicated by the \blacktriangleleft character in the last column of the display.

To edit an enumeration field, place the cursor at the desired field by using the Navigation keys. Then, use the \blacktriangleright or \blacktriangleleft key to scroll through all of the possible choices in sequence.

When a field has been changed, a block cursor will flash over the  symbol. Each time the  or  key is pressed, the field value will scroll forward or backward through all of the available choices.

To select the displayed value, press the **Enter** key. To cancel selection without updating the field, press the **Esc** key. The cursor will then return to the  symbol.

The Keypad Keys and Numeric Data Fields

A numeric data field is indicated by a pound-sign (#) in the last column of the display.

The Keypad Keys are used to enter data into numeric fields. These keys are: the numerals **0** through **9**, the period key (.) and the **+/-** key.

When the cursor is positioned to a field that requires numeric data, the Keypad Keys become hot and pressing one of them will result in the field being selected and numeric entry initiated. This is indicated by a flashing cursor.

When the **Enter** key is pressed, numeric data in the selected field will be checked for range and the instrument's database will be correspondingly updated.

If the numeric entry is outside of the required range, an error is indicated by the display of the previous value of the field.

Once the entry of numeric data has started, it can be aborted by pressing the **Esc** or **Home** key. This will cause the field to be de-selected and its value will be unchanged.

 **Note:** Up to 20 digits may be entered in a numeric field. When digit entry has exceeded the display field width, additional characters will cause the display to scroll from right to left. When entry is complete, the updated display field may not show all of the digits entered because of limited field width, however, the digits are retained to the full precision of the controller's internal 32 bit floating point format.

Summary of keypad functions

Key	Function	Description
	Power	Toggle power. Must be held in for two seconds in order to toggle AC power.
	Stop	Disengage all control loops.
	Control	Engage all control loops.
	Home	Go to the Home Status Display.
	Enter	Enter data / make a selection.
▲	Esc	Scroll Display UP. If in a selection mode, abort entry and return to the Home Status Display.
▼		Scroll Display DOWN.
▶		Scroll to NEXT selection.
◀		Scroll to PREVIOUS selection.
.	Display	Go to the Display Setup menu.
±	Set Pt	Change the setpoint value for either control loop.
o	Alarm	Go to the Alarm Status menu.
1	ChA	Sensor input A setup menu.
2	ChB	Sensor input B setup menu.
3	LOOP 1	Primary control loop setup, Loop 1.
4	Config	User configuration save and restore.
5	Sys	System functions menu.
6	Loop 2	Loop 2 setup menu.
7	Sensors	Sensor data and calibration curve menu.
8	PID Table	PID table menu.
9	Auto Tune	Autotune menu.

Table 6: Keypad key functions.

The LED indicators and Audible Alarm

There are three LED indicators located just below the main display as shown here:

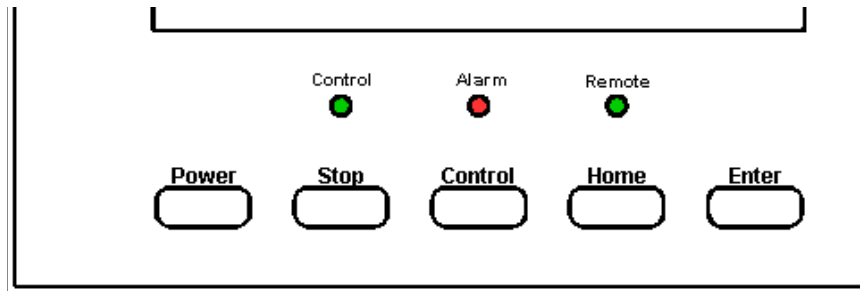

The Green **Control** LED is illuminated whenever either of the control loops are engaged and actively controlling temperature. To disengage the loops, press the **Stop** key.

The Red **Alarm** LED is illuminated whenever a user programmed has been triggered. To clear the alarm, the enabled event that is asserting the alarm must be disabled.

The Green **Remote** LED can be turned on or off under program control by the remote interface. Use of this LED by a computer connected to the instrument is optional.

The VFD Display

Home Status Displays

At the top of the instrument's menu tree are the home status displays. They can be selected from anywhere in the instrument's menu tree by pressing the **Home** key.

The list of display configurations is accessed by pressing the **Display** key:

1. Dual Input Status (default)
2. Loop 1 Status
3. Loop 2 Status
4. Dual Loop Status
5. Ch A Statistics
6. Ch B Statistics

Select the desired configuration and press the **Enter** to return to the Home display.

Dual Input Status Display

This is the factory default display. It shows the status and current input temperature for both control loops.

Input channel A is shown on the left and channel B on the right.

A87.4567K	B104.932K
1 15% Hi	2 28% 10W

The second line of the display shows the Loop Status Display. Directly above each Loop Status is a temperature for the controlling input channel. In the example here, Loop 1 is being controlled by input channel A and Loop 2 is being controlled by input channel B. Please note that either loop may be controlled by either input. The display will be adjusted to show the control loop directly below the controlling input channel.

The next example shows the control inputs reversed, Loop 1 controlling in the low power range and Loop 2 off.

Loop 1 and Loop 2 Status Displays

These displays show the current status of a selected single control loop. Information includes the controlling input channel, temperature, setpoint, heater status and heater bar chart.



In the example shown here for Loop 2, the loop is controlling from input B with 30% output power and the setpoint is 17.0000K.



Dual Loop Status

The Dual Loop Status display is similar to the Dual Input Status display described above. However, on this display, control loop #1 is always on the left side and loop #2 is always on the right.

Channel A and B Statistics Display

The Channel A and B statistics displays show the selected input channel temperature, the slope of the temperature history, the minimum and maximum temperatures.

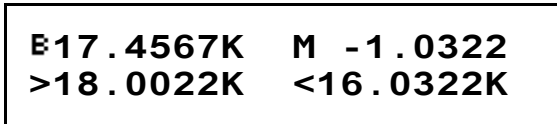

The slope of the temperature history (M) is given in Display Units per Minute. In this example, Display Units are Kelvin.

Temperature Displays

A typical Input Channel Temperature Display is shown here. It consists of the input channel designator, a Temperature reading and the current temperature units.

The input channel designator is a superscripted A or B.

The temperature is a seven-character field and is affected by the Display Resolution setting in the **Sys** menu. This setting may be 1, 2, 3 or Full. Settings of 1, 2, or 3 indicate the number of digits to the right of the decimal point to display whereas the Full setting causes the display to be left justified in order to display the maximum number of significant digits possible.

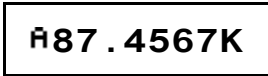

The Display Resolution setting does not affect the internal accuracy of arithmetic operations. It is generally used to eliminate the display of unnecessary digits that are beyond the sensor's actual resolution.

If the Input Channel has been disabled, a blank display is shown.

Temperature units are selected in the individual input channel setup menus, **ChA** or **ChB**. Temperature Units may be K, C or F. When Sensor Units (S) is selected, the raw input readings are displayed. These will be in Volts or Ohms.

K	Kelvin
C	Celsius
F	Fahrenheit
Ω	Ohms
V	Volts

Table 7: Temperature Units

Sensor Fault Display

A sensor fault condition is identified by a temperature display of seven dash (-) characters as shown here. The sensor is open, disconnected or shorted.

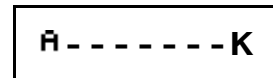

Temperature Out of Range Display

If a temperature reading is within the measurement range of the instrument but is not within the specified Sensor Calibration Curve, a display of seven dot (.) characters is shown.



Note: In some cases, there will be an erratic temperature display when no sensor is connected. This is not an error condition. The high input impedance of the controller's input preamplifier causes erratic voltage values when left unconnected.

Loop Status Displays

When the Model 32 is not controlling temperature, the status of the Loop output is shown.

The first character of the Loop Status Display is always the loop number, which will be either a superscripted 1 or 2 corresponding to Loop 1 or Loop 2.

The Loop number will be followed by the heater status as follows:

1. **-OFF-** Indicates that heater output is functional and the control loop is off or disabled.

¹ - OFF - Low

For the primary heater, Loop 1, the range is also shown. Range settings may be either **Hi**, **Mid** or **Low**. The range is set in the **Loop 1** menu.

For the secondary output, or Loop 2, the range will be shown as **10W** for a Model 32B, or **10V** for a Model 32.

2. **Overtemp** indicates that the controller's Internal Temperature Monitor circuit shut off the heater. This fault is usually the result of a shorted heater, or use of a heater with significantly less resistance than the selected load resistance.

¹Overtemp

3. **Readback** indicates that the Current Readback Monitor circuit has shut down the heater. This monitor compares the actual heater output Current with the indicated output Current and asserts a fault condition if there is a difference. This fault is usually the result of a broken heater cable or an open heater.

¹Readback

4. **SensorFLT** indicates that the heater was shut down by a fault condition on the on the controlling input channel. This is usually caused by an error in the sensor or sensor cables. None: A sensor fault will not shut down the heaters if the loop is in Manual output mode.

¹SensorFlt

5. **OTDisconn** indicates that the heater output was disconnected by the Over Temperature Disconnect Monitor. This monitor is configured by the user and functions to disable the heater if a specified over temperature condition is exists on a selected input channel. See the **Sys** menu for information on how to configure and use this important feature.

¹OTDisconn

If the Model 32 is controlling temperature (loop ON), the heater status display shows the loop output as a percentage of full scale.

This example shows the Heater Status for Loop 2 in a Model 32B controller. The unit is in control mode and is outputting 30% of full scale output current. This means that the output power is $(30\%)^2$, or 9% of 10 Watts.

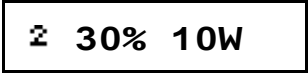

2 30% 10W

The Loop Bar Chart Display

The Loop Bar Chart is a 50-segment bar chart that shows the measured output of a selected loop output.

The bar is composed of ten blocks with five segments. Therefore, output current can be read to an accuracy of 2%.

Note that the bar chart does not have a loop number indicator.

Some examples are:

Loop ON, zero output:

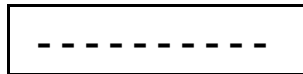

Loop OFF:

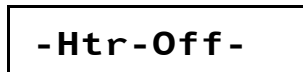

Loop ON, 50% output:



Note: The Model 32 uses an independent circuit to read current actually flowing through the load. The heater bar graph shows this measured current. If the unit is controlling temperature, but the bar graph indicates zero current flow, an error condition exists, possibly an open heater.

Front Panel Menu Operation

Instrument Setup Menus

The various instrument setup menus are accessed by pressing one of the Setup Menu keys. The display must be in 'Home Status' in order for these keys to be active.

The user may exit a Setup Menu and return to the Home Status display at any time by pressing the **Home** key.

The first one, or more characters on a line identify the specific menu. For example, the first character of every line in the Loop 1 setup menu is the loop identifier, which is a superscripted 1.

Menus contain several lines, so the display must be scrolled by using the ▲ and ▼ keys.

The last character of each line in a setup menu is the format indicator. The indicator will be blank until the cursor is moved to the line.

Format indicators are:

- # - Numeric entry is required
- - Enumeration entry using the ▸ and ◀ keys.
- - The line is selected by pressing the **Enter** key.

The Setpoint Menu

The setpoint menu is accessed by pressing the **Set Pt** key. This gives one-key access to the setpoints for both control loops. The following 2-line menu will be shown.

<pre> 1Setpoint = 320.000K# 2Setpoint = 100.000K </pre>

The pound sign (#) character at the end of the top line is the cursor. Use the ▲ and ▼ keys. to move the cursor between control loop 1 and 2. The location of the cursor is remembered so that it will point to the same loop each time.

To enter a new setpoint, use the numeric keys and then press the **Enter** key. This will update the setpoint on the selected control loop and return the display to the Home display.

Press the **Home** key to exit the menu without update.

The Alarm Status Display Menu

The current status of the temperature alarms may be viewed by pressing the **Alarm** key. A display like this one will be shown:

Alarms are set for each input channel using the Input Channel Setup menu described below.

```
Alarm LO -- L
Alarm -- HI
```

When an alarm is asserted, the Alarm LED on the front panel will light. Pressing the **Alarm** key will display all of the alarms. Status is shown as follows:

—	No alarm
LO	Low temperature alarm
HI	High temperature alarm

The letter L at the end of the line indicates that the alarm is latched. A latched alarm is asserted when the alarm condition is set. It stays asserted until it is manually cleared by the user.

 **Note:** To clear a latched alarm, first press the **Alarm** key to view the alarms and then press the Home key to clear the latch and return to the **Home** display.

The Display Configuration Menu

The display configuration menu is accessed by pressing the **Display** key. When accessed, the menu will appear as a list of possible configurations. The cursor, indicated by a **■** character, will be located at the current configuration. Use the **▲** and **▼** keys to move up and down the list.

Display configurations are:

Dual Input Status	(Default). Input channel status. Displays temperature of both input channels and the status of any control loop assigned to the inputs.
Loop 1 Status	Detailed status of control loop #1. Temperature of controlling input channel, set point, heater status and bar graph.
Loop 2 Status	Detailed status of control loop #2. Temperature of controlling input channel, set point, heater status and bar graph.
Dual Loop Status	Control loop status. Displays the status of both control loops on the second line of the display. On the first line the temperature of the controlling input is shown.
Ch A Statistics	Temperature statistics for input channel A. Shows current temperature, maximum, minimum and accumulation time. For additional statistical information, refer to the Input Channel Setup Menu . Note: Pressing the Enter key will reset the statistics.
Ch B Statistics	Temperature statistics for input channel A. Shows current temperature, maximum, minimum and accumulation time. For additional statistical information, refer to the Input Channel Setup Menu . Note: Pressing the Enter key will reset the statistics.

Table 8: Display Configurations

Select the desired configuration and press the **Enter** to return to the Home display. Refer to the section "[Home Status Displays](#)" for more information.

Input Channel Setup Menu

The Input Channel Setup menus are selected by pressing the **ChA** or **ChB** keys from a Home Status Display. These menus contain all of the user-configurable parameters for a selected sensor input channel.

The first character on each line of these menus is always the input identifier, which is a superscripted A or B for Input A or Input B.

Use the **▲** and **▼** keys to move up and down the list.

ChA, ChB Setup Menu		
1	Ḃ 77.123 K ↔	Input channel units. Temperature is displayed on the left and is in the selected units. Selections are K, C, F or S. Here, S selects primitive sensor units. When S is selected, the actual sensor units of Volts or Ohms will be displayed.
2	ḂSen:I20 Pt100 385 ↔	Sensor type selection. Allows selection of any user or factory installed sensor. The I20 shown indicates that the current sensor is factory installed sensor #20.
3	ḂCalGen ■	Selecting this field by pressing the Enter key will take the display to the CalGen™ screen.
4	ḂHigh Alarm:200.000#	Setpoint for the High Temperature alarm. Use the keypad for numeric entry and then press the Enter key.
5	ḂHigh Enable: No ↔	High temperature alarm enable. Selections are Yes or No.
6	ḂLow Alarm: 200.000#	Setpoint for the Low Temperature alarm.
7	ḂLow Enable: Yes ↔	Enables latching alarms on the selected input channel.
8	ḂAudible Ena: Yes ↔	Enables the internal audio alarm to sound on any enabled alarm condition.
9	ḂLatch Enable: Yes ↔	Enables or disables latching alarm conditions. A latched alarm is cleared by pressing the Alarm key followed by Home key.
10	ḂMax: 77.5232K ■	Continuously displays the Maximum temperature on this input channel. Pressing the Enter key resets.
11	ḂMin: 77.0232K ■	Continuously displays the Minimum temperature on this input channel. Pressing the Enter key resets.
12	ḂAccum: 1.25 Min ■	Displays the accumulation time for the input channel statistics. Pressing the Enter key resets.

ChA, ChB Setup Menu (cont)		
13	RS2: 1.0543 K <input type="checkbox"/>	Displays the variance of the input channel temperature over the accumulation time. Pressing the Enter key resets the accumulation time.
14	RM: 1.115 K/Min <input type="checkbox"/>	Displays the slope, or rate of change, of the input temperature over the accumulation time. Pressing the Enter key resets the accumulation time.
15	Rb: 76.02 K <input type="checkbox"/>	Displays the offset of the input temperature over the accumulation time. The M and b statistics are the slope and offset of a straight-line fit to the input channel temperature. Pressing the Enter key resets the accumulation time.
16	RBias Voltage: 10mV <input type="checkbox"/>	Selects sensor bias type. Applies only to resistor sensors that use constant-voltage excitation. All others show N/A. Choices are: 10mV, 3mV and 1.0mV

Table 9: Input Channel Setup Menus.

Temperature Units

Enumeration, Default: K

The Temperature Units field (line 1) assigns the units that are used to display temperature for the input channel. Options are K for Kelvin, C for Celsius, F for Fahrenheit and S for sensor units. Note that if the S option is selected, the actual sensor units will be displayed when the field is deselected. Available sensor units are V for Volts and Ω for Ohms.

Use the **▶** or **◀** key to scroll through all of the options. When the desired units are displayed, press the **Enter** key to make the selection. The display will now show the current temperature with the new units.

Sensor Type Selection

Enumeration

Line 2 selects the Sensor type for the input channel. When this field is selected, the scroll keys are used to scroll through all of the available sensor types. Factory installed sensors appear first and then user sensors. For a list of both factory and user sensors, refer to [Appendix A](#).

New user sensor types and calibration curves are added using the **Sensors** menu.

CalGen™

Selection of the CalGen™ field initiates the calibration curve generator feature. This feature is described in the section [“CalGen Calibration Curve Generator”](#).

Setting a Temperature Alarm

The Alarm lines are used to setup alarm conditions. The Model 32 allows alarm conditions to be assigned independently to any of the input channels.

High temperature and low temperature alarms may be entered and enabled. Note that there is a 0.25K hysteresis in the assertion of high and low temperature alarms.

Alarm conditions are indicated on the front panel by the Alarm LED and various display fields. They are also reported via the remote interfaces.

When the audible alarm is enabled, a high-pitched buzzer will sound when an alarm condition is asserted.

The Model 32 supports latched alarms. These are alarms that remain asserted even after the condition that caused the alarm has been cleared. To clear a latched alarm, first press **Alarm** to view the Alarm Status Display and then press the **Home** key to clear.

Input Channel Statistics

The Model 32 continuously tracks temperature history on each input channel. The Input Statistics shown in this menu provides a summary of that history.

The channel history is reset whenever the channel is initialized and can also be reset by pressing the **Enter** key while the cursor is on any of the statistics lines.

The **Accum** line shows the length of time that the channel history has been accumulating. It is in units of Minutes.

The **Minimum** and **Maximum** temperature lines show the temperatures from during the accumulation time. Values are shown in the currently selected display units.

S2 is the temperature variance, which is computed as standard deviation squared.

The **M** and **b** fields display the slope and the offset of the LMS best-fit straight line to the temperature history data.

Bias Voltage Selection

Enumeration, Default: 10mV

The Model 32 supports constant-voltage AC excitation for resistor sensors. Other sensors, including diodes, are supported by DC constant-current excitation.

Sensor type ACR indicates an AC resistor sensor that uses constant-voltage bias. Here, the Bias Voltage field will show selections of 10.0mV, 3.3mV and 1.0mV to indicate the voltage that is held on the sensor. The Model 32 has an autoranging current source that will maintain the selected voltage.

For sensor types other than ACR, the Bias Voltage field will show N/A for not applicable.

Additional information on excitation voltages and currents is given in the section "[Input Channels](#)".

The Control Loop Setup Menu

The control loop setup menus are selected by pressing the **Loop 1** or **Loop 2** key from a Home Status Display. These menus contain all of the user-configurable parameters for the selected control loop.

The **Loop 1** menu is used to perform the setup of the primary 25/50 Watt heater output. This display was designed to provide all of the information required to tune heater parameters and is, therefore rather complex.

The **Loop 2** menu is used to perform the setup of the secondary output. For a standard Model 32, this is a zero to 10 Volt output. For a Model 32B this is a 10 Watt current source.

The first character on each line of the control loop setup menu is always the loop identifier, which is a superscripted 1 or 2 for Loop 1 or Loop 2.

Loop #1, Loop #2 Setup Menu		
1	1 77.123K 5 79.000K#	Numeric setpoint entry. The temperature of the controlling input is shown on the left and is continuously updated. Use the keypad to enter a new setpoint and then press the Enter key. Control loop setpoints may also be accessed from the Set Pt key.
2	1Pgain: 25.0000 #	Proportional gain, or P term for PID control.
3	1Igain: 71.0000S #	Integrator gain term, in Seconds, for PID control.
4	1Dgain: 71.0000/S #	Derivative gain term, in inverse-Seconds, for PID control.
5	1Pman: 25.00% #	Output power, as a percent of full scale, when controlling in the Manual mode.
6	1Input: ChA ↵	Control input channel, ChA or ChB
7	1Range: HI ↵	Output power range. For loop 1, this will be HI, Mid or Low. For loop 2 on a Model 32, it will be 10V and for a Model 32B, it will be 10W.
8	1Type: PID ↵	Control Type. Selections are: Off, Man, PID, RampT, RampP and Table.
9	1Power Limit: 100% #	Power limit as a percent of full scale. On loop 1, this limit only applies to the HI range.
10	1Max Setpt: 1000.00K#	Maximum value allowed for the setpoint on this loop.
11	1PID Table index: 0#	Table number for control in Table mode. The Model 32 has six PID tables numbered from zero through five.
12	1Htr Resistance: 50Ω ↵	Sets the heater load resistance. Selections are 25 and 50.
13	1Ramp: 0.10 /min #	Ramp rate in temperature units per minute.

Table 10: Control Loop Setup Menus.

Setpoint

Numeric Entry

The first line of this menu the user can change the setpoint, while still viewing the temperature of the controlling source channel. This allows the user to view the temperature without leaving the setup menu.

 **Note:** Entry of a setpoint can be overridden by the Maximum Setpoint field described below. The instrument will not accept an entry that exceeds the maximum.

Control loop setpoints may also be entered by using the **Set Pt** key.

Control Loop PID values

Numeric Entry

The Pgain, Igain and Dgain lines correspond to the Proportional, Integral and Derivative coefficients of the control loop. Pman is the output power that will be applied to the load if the manual control mode is selected.

Values for the Proportional, or P, gain term range from zero to 1000. This is a unit-less gain term that is applied to the control loop. Gain is scaled to reflect the actual heater range and the load resistance.

Integrator gain values range from zero to 10,000. The units of this term are Seconds. A value of zero turns the integration function off.

Derivative gain values have units of inverse Seconds and may have values from zero to 1000. A value of zero turns the Derivative control function off.

The Pman field is only used when the heater output is in manual control mode. The value is in percent of full-scale output power (Watts) and may have values from zero to 100%.

 **Note:** The Model 32 expresses heater output values in terms of percent of full-scale output power. The actual power, in Watts, applied to the load is proportional to the square-root of output current.

Control Source Input Channel Enumeration, Default: Loop #1- ChA Loop #2- ChB

The input field selects the control loop source input. Any input channel may be selected.

Control Loop Range

Enumeration, Default: Loop #1- Low

The Range field selects the full-scale output for the selected control loop.

For Loop #1, settings are HI, MID and LOW. The actual full-scale output power is determined by this setting along with the load resistance. See the [Heater Output Ranges Table](#) for more information.

The full-scale output range for Loop #2 is fixed and cannot be changed by using the Range field. For a Model 32, the output is a 0 to 10Volt voltage source. For the Model 32B, the output is a 10 Watt linear current source.

Control Types

Enumeration

The Type field selects the actual control algorithm used for the selected loop. Selections are: Off, PID, Man, Table and RampP.

Loop control modes are:

1. **Man** for Manual control mode. Here, a constant heater output power is applied when the unit is controlling temperature. The Pman field selects the output as a percentage of full-scale.
2. **Table**. This is a PID control mode where the PID coefficients are generated from a stored PID table based on setpoint.
3. **PID** for standard PID control.
4. **Off**. In this mode, the controller will not apply power on this output channel. Note that the Model 32 is a dual-loop controller. The Off control mode is used if regulation is desired only on the other channel.
5. **RampP**. This is a temperature ramp mode. When a ramp operation is complete, the controller will revert to standard PID mode control at the final setpoint.

For more information on control algorithms, refer to the [Heater Control Types](#) table above.

For more information on temperature ramps, refer to the section on [Temperature Ramping](#) below.

Output Power Limit

Numeric entry, Default: 100%

The Power Limit field defines the maximum output power that the controller is allowed to output. It is a percent of the maximum allowed output. Maximum value is 100% and minimum is 15%.

For Loop #1, the Power Limit is applied to the HI range only. For lower power levels on this loop, select either the MID or LOW range.

For Loop #2, the Power Limit is always applied.

 **Note:** Output Power Limit is an important cryostat protection feature. The user is encouraged to apply it.

Maximum Setpoint

Numeric Entry, Default: 1000K

The Maximum Setpoint field is used to prevent the casual user from inadvertently entering a temperature that might damage the cryostat.

Maximum value is 10,000K and minimum is 0K.

Setpoint values use the temperature units selected for the controlling input channel. See the section on [Temperature Displays](#).

 **Note:** The Maximum Setpoint selection is an important cryostat protection feature. The user is encouraged to apply it.

PID Table Index

Numeric entry, Default: 0

The PID Table index line is used to identify the number of the user supplied PID Table that will be used when the Table control mode is selected. The Model 32 will store up to six PID Tables. They are numbered zero through five.

Heater ResistanceEnumeration, Default: 25 Ω

The heater resistance field is an enumeration that sets the value of the heater load resistance. Choices are 50 Ω and 25 Ω . When 50 Ω is selected, the heater will output a maximum of 50 Volts at 1.0 Ampere or 50 Watts. When 25 Ohms is selected, the maximum heater voltage is 25 Volts and the output power is 25 Watts.

For additional information, please refer to the [Heater Ranges](#) table above.



Warning: It is necessary to set the Load resistance field to the actual value of the heater load resistance being used. If an incorrect value is selected, output power indications will be incorrect and non-linear heater operation may result. If the actual heater resistance is less than selected, the heater may overheat resulting in an automatic over temperature shutdown.

Ramping Rate

Numeric entry, Default: 0.10/min

When performing a temperature ramp, the Ramp field defines the ramp rate. Units are display units per minute. In the default case, this means Kelvin per minute.

For more information on temperature ramps, refer to the section on [Temperature Ramping](#) below.

User Configurations Menu

The User Configurations Menu is displayed by pressing the **Config** key. It is used to save or restore up to four instrument setups. Each setup saves the entire state of the Model 32 including setpoints, heater configurations, input channel data etc.



User Configurations Menu		
1	Config-UserConfig0 	Selects the user configuration. The Model 32 has four configurations available.
2	Config-Save 	Pressing the Enter key saves the instrument setup to the selected configuration number.
3	Config-Restore 	Pressing the Enter key restores a saved configuration.

Table 11: User Configurations Menu

To save or restore a setup, select the desired configuration number on line 1. Then, move the cursor to either Save or Restore and press the **Enter** key.

When a configuration has been saved, the menu shown here will be displayed indicating that the current instrument setup has been written to the controller's FLASH memory and may be retrieved by using the Restore function.

**Configuration saved
Press Home to exit**

If the user attempts to restore an invalid configuration, an error display is shown. This is usually caused by attempting to restore a configuration that was never saved.

Config. restored

When a configuration is successfully restored, the display shown here is shown. After a one or two seconds, the controller will automatically perform a power-up reset with the restored data.

The System Functions Menu

This menu is accessed by pressing the **Sys** key from the Home Status Display. It is used to set many of the instrument's parameters including display resolution, I/O port settings etc.

System Functions Menu		
1	SYS-Display TC=2.0S	Sets the display time constant in seconds. Selections range from 0.5S to 64S
2	SYS-Display RS=Full	Sets the resolution. Selections are: 1, 2, 3 or Full.
3	SYS-CJ Comp Ena: ON	Enables or disables Cold Junction Compensation for Thermocouple sensors. Only shown when the thermocouple option is present.
4	SYS-CJoffset: 0.00#	Offset, in °C, applied to thermocouple Cold Junction Compensation. Only shown when the thermocouple option is present.
5	SYS-Brightness= 0	Display brightness. Selections are 0,1,2 and 3
6	OTD-Enable: Off	Sets the Over Temperature Disconnect enable. Selections are On or Off.
7	OTD-Source: ChA	Sets the Over Temperature Disconnect source input channel. Selections are ChA or ChB.

System Functions Menu (cont.)		
8	OTD-T: 300.000 #	Sets the Over Temperature Disconnect setpoint temperature.
9	RIO-Port: RS232↵	Selects the port for remote I/O. Selections are RS232 or GPIB.
10	RIO-Address: 12 #	Sets GPIB I/O address. It is a numeric entry with a range of 1 to 31. Default is 12.
11	RIO-RS232: 19K ↵	Sets RS-232 port baud rate. Selections range from 300 to 38K baud.
12	Sync Filt. Taps: 07#	Advanced configuration: Number of taps in the synchronous filter. Normally set to a value of 7.
13	SYS-AC Line: 60 ↵	AC line frequency. Select 50 or 60Hz.
14	SYS-Auto Ct1: Off↵	Power Up Mode. Off for normal operation. On to engage the control loops 10 seconds after power has been turned on.
15	>	Remote I/O: Last command received.
16	<	Remote I/O: Last response.

Table 12: System Functions Menu

Display Time Constant

Enumeration, Default: 2 Seconds

The SYS-Display TC field is used to set the display time-constant. This is an enumeration field that sets the time constant used for all temperature displays. Choices are 0.5, 1.0, 2.0, 4.0, 8.0, 16.0, 32.0 and 64 Seconds.

The time-constant selected is applied to all channels and is used to smooth data in noisy environments. The filtering only applies to displayed data; it is not used by the control loops.

Display Resolution

Enumeration, Default: 3

The Display Resolution line (SYS-Display RS) is used to set the temperature resolution of the front panel display. Settings of 1, 2 or 3 will fix the number of digits to the right of the decimal point to the specified value. A setting of FULL will left-justify the display to show maximum resolution possible.

Note that the Display Resolution setting only formats the display as a user convenience. The internal resolution of the Model 32 is not affected by this setting.

Display Brightness

Enumeration, Default: 2

The SYS-Brightness field is used to control the brightness of the display. Selections are 0, 1, 2 and 3 with 0 being the brightest. This control does not take effect until the next power-up.

Over Temperature Disconnect

The Over Temperature Disconnect (OTD) feature is configured using the OTD- lines. This feature allows the user to specify an over temperature condition on any of the input channels.

Whenever an over temperature condition exists on the selected channel, the heaters outputs are disconnected and the Loop Status indicator is set to "OTDisconn".

Both loops are disconnected when an over temperature condition exists. A mechanical relay is used so that the load is protected, even if the condition was caused by a fault in the controller's output circuitry.

The OTD must first be configured to monitor one of the input channels. Note that the OTD feature is completely independent of control loop function and may monitor any input.

Next, an OTD Setpoint must be specified. This is the temperature at which an over temperature shut down will be asserted. Temperature units are taken from the source input channel.

Finally, the OTD function must be enabled.



Important: The Over Temperature Disconnect is an important cryostat protection feature. The user is encouraged to apply it.

Remote I/O Port Configuration

The RIO- lines are used to configure the Remote I/O interfaces including the GPIB and RS-232.

Note that 'GPIB' is used to indicate the controller's IEEE-488.2 interface.

Port Select (RIO-Port) is an enumeration field that sets the active remote port. The controller can only have one active port at a given time. Inactive ports are disabled. Choices are RS-232 and GPIB. The factory default is RS-232.

The address line (RIO-Address) is a numeric field that may have a value between 1 and 31. The factory default is address 12. This field is used by the GPIB interface to select individual instruments. It is the user's responsibility to configure the bus structure with unique addresses for each connected instrument.

RS232 Rate is an enumeration of the RS-232 baud rate. Choices are 300, 1200, 2400, 4800, 9600, 19k for 19,200 and 38K for 38,400.

Synchronous Filter Configuration

Numeric Entry Default: 7

The Synchronous Filter is used to subtract synchronous noise from the input channel. An example of synchronous noise is the thermal signature of a cryocooler.

The default value of 7 taps is used for a line-frequency synchronous cryocooler. Values go from 1 (off) to 25 taps with 25 corresponding to 2.5 seconds of filtering.

This is an advanced setup function. Unless you are familiar with the synchronous noise source that you are trying to remove, leave this field at its default value of 7.

When the number of taps is changed, the control loops will have to be re-tuned because this filter affects the PID values.

AC Line Frequency Selection

Enumeration, Default: 60Hz

Select the AC power line frequency. Choices are 50 or 60 Hz. This function only affects the operation of the Synchronous Filter described above.

Power-up in Control Mode.

Default: Off

The SYS-Auto Ctl: field sets the power up mode of the controller's loops. Choose 'Off' for normal operation where the control loops are engaged by pressing the **Control** key and disengaged by pressing the **Stop** key. When SYS-Auto Ctl is ON, the controller will power up, then after ten seconds, will automatically engage the control loops.

Remote I/O transactions

The last two lines of the SYS menu are the Remote I/O input and output lines. These are used to assist in debugging programs that use the controller over one of its remote interfaces. The remote input line (>) shows the last complete command received and parsed by the controller. The remote output line (<) shows the response that the command generated.

PID Tables Menu

The Model 32 can store four user generated PID tables. Each table may have up to sixteen setpoint zones.

Each setpoint zone in a table requires the entry of a setpoint along with corresponding values for P, I, D and full scale heater range.

When controlling in the Table mode, the Model 32 will derive control loop PID coefficients and heater range by interpolation of the PID Table zones based on that zone's setpoint.

PID Tables can be used with both control loops.

Building a table from the front panel requires the entry of several numeric values. For this reason, the user may want to consider using one of the remote interfaces.

The start, and top level, of this process is the PID Tables menu. Two menu screens below this are used to enter numeric data. Here is an overview of the process:

1. The PID Tables menu is used to select the PID Table number (zero through three).
2. Once the table is identified, selecting the EDIT PID TABLE line will take the menu used to edit individual lines of the selected table.
3. To enter or edit an entry, set the desired entry index and enter the zone data on the following lines.
4. The last line of this menu is used to save the table when line entry is complete.

When a table is saved, it is automatically conditioned so that it can be used directly by the control loop software. The conditioning deletes all entries with setpoint values of zero or less and sorts the table based on setpoint. Therefore, an entry may be deleted by setting the setpoint to any negative number.

The PID Table Menu

The PID Table Menu is accessed by pressing the **PID Table** key from the Home Display.

The first three characters of each line on the initial PID Table menu are a two-digit index followed by a single vertical bar. The index identifies the currently selected table and will change whenever the table number is updated.

PID Table Menu			
1	01 PID Table 1	↩	Sets the PID table number for editing. Selections are 0 to 3.
2	01 N	5 #	Displays the number of zones in the selected PID table. Note. This number is generated from the selected table and cannot be changed in this menu.
3	01 Edit PID Table	■	Pressing the Enter key on this line will take the display to the second level menu where the selected table is entered.

Table 13: PID table Menu

The first line (01) is the table index. This field is used to select a table for editing.

Below this is N, the number of valid entries in the table. This number was generated when the user entered table and cannot be changed using this menu.

Sensor Setup

The Sensor Setup menu is used to view and edit user temperature sensor data.

The Sensor Setup Menu

Pressing the **Sensor** key from the Home Status Display accesses the Sensor Setup Menu.

Definition of a sensor requires entering configuration data on this screen followed by entering a calibration curve.

The first three lines of the Sensor Setup Menu show the Sensor Index followed by a 'greater than' (>) character. This > character indicates the first level of the Sensor Setup menu.

Sensor Setup Menu		
1	18>User Sensor 4 ▶	Sets the Sensor Index. Scroll through choices until the desired sensor is displayed and press Enter .
2	18>Type: Diode ▶	Sets the Sensor Type, which includes voltage range and excitation. Selections are described in the Sensor Type table above.
3	18>Mult: -1.0 #	Sets the sensor Temperature Coefficient and Calibration Curve Multiplier.
4	18>Units: Volts ▶	Sets Units of the sensor's Calibration Curve. Choices are: Ohms, Volts and LogOhm.
5	18>Edit Cal Curve ■	Pressing Enter will display the next level menu where the sensor's Calibration Curve data may be viewed and edited.

Table 15: Sensor Setup Menu

The first line on this menu is the sensor table index. Selecting this field will allow scrolling through all of the sensors configured in the unit, including user sensors. The index is displayed along with the sensor name.

Note: the sensor name may be entered via any of the Remote I/O interfaces, but may not be changed from the front panel.

Sensor Type is an enumeration of all of the basic sensor types supported by the Model 32. Choices are shown in the [Supported Sensor Configurations](#) table above.

The **Multiplier** field is a floating-point numeric entry and is used to specify the sensor's temperature coefficient and to scale the calibration curve. Negative multipliers imply that the sensor has a negative temperature coefficient. The absolute value of the multiplier scales the calibration curve. For example, the curve for a Platinum sensor that has 100Ω of resistance at 0°C may be used with a 1000Ω

sensor by specifying a multiplier of 10.0. Also note that the temperature coefficient field is only used when the unit is controlling temperature based on the sensor units of Volts or Ohms.

Units is an enumeration field that identifies the primitive units used by the sensor's calibration curve. Choices are Volts, Ohms and LogOhm. LogOhm selects the base ten logarithm of ohms and is useful with sensors whose resistance vs. temperature curve is logarithmic.

Selecting the 'EDIT CAL CURVE' field will cause the screen to go to the Calibration Curve menu for the selected sensor. Here, the calibration curve may be viewed or edited.

The Calibration Curve menu

The Calibration Curve menu is the first screen used in the process of building a sensor calibration curve. Note that these curves can have up to 200 points requiring the entry of 400 floating point numeric values. For lengthy curves, you may want to consider using one of the remote interfaces. Cryocon provides a free PC utility that will upload or download curves that can be created by a text editor.

The entry of a sensor calibration curve is essentially identical to the process used to enter PID Tables. The procedure for entering or editing a calibration curve is summarized as follows:

1. The sensor's calibration curve is accessed from the Sensor Setup menu detailed above.
2. Data points in the selected curve are entered by first entering the entry index, then values for sensor readings vs. corresponding Temperature.
3. When all data points have been entered, the SaveCurve&Exit field is selected to save the curve.

Once complete, the controller will condition the curve by rejecting invalid entries, then sorting the curve in order of ascending sensor unit values. Therefore, an entry may be deleted by placing a zero or negative number in either the temperature field.

The first four characters of a Calibration Curve Menu show the two-digit sensor index followed by either the sequence >>.

Calibration Curve Menu		
1	18>>IX: 123 #	Sets the current index to an entry within the current table. Values are 0 to 159. When the Enter key is pressed, the following lines will display any data corresponding to the selected entry.
2	18>>T: 232.0050 #	Temperature. Units are always in Kelvin.
3	18>>S: 1.00002 #	Sensor reading. Units are taken from the Sensor Setup menu described above.
4	18>>SaveCurve&Exit ■	Pressing Enter will display the next level menu where the sensor's Calibration Curve data may be viewed and edited.

Table 16: Calibration Curve Menu

The Auto Tune Menu

The Model 32 can automatically tune both control loops. For a complete description of the autotune process including configuration of the tuning menus, refer to the section titled [autotuning](#).

Specifications, Features and Functions

Specification Summary

User Interface

Display Type: 20 x 2 character VFD, 9mm character height.

Number of Inputs Displayed: Two.

Keypad: Sealed Silicon Rubber.

Temperature Display: Six significant digits, autoranged.

Display Update Rate: 0.5 Seconds.

Display Units: K, C, F or native sensor units.

Display Resolution: User selectable to seven significant digits.

Input Channels

There are two input channels, each of which may be independently configured for any of the supported sensor types.

Sensor Connection: 4-wire differential. DIN-5 input connectors mate with either DIN-5 or DIN-6 plugs. Connections are described in the [“Sensor Connections”](#) section.

Supported Sensors: Include:

Type	Excitation	Temperature Range
Cernox™	Constant-Voltage AC	0.3 to 420K
Ruthenium Oxide	Constant-Voltage AC	200mK to 273K
Thermistors	Constant-Voltage AC	70 to 325K
Rhodium-Iron	1mA DC	1.4 to 800K
Germanium	Constant-Voltage AC	0.3K to 100K
Carbon Glass™	Constant-Voltage AC	1.4K to 325K
Silicon Diode	10μA DC	1.4 to 475K
Platinum RTD	1mA DC	14 to 1200K
GaAlAs Diode	10μA DC	25K to 325K
Thermocouple	None	Option, >1.4K

- Sensor Selection:** Front Panel or remote interface. There are no internal jumpers or switches.
- Sensor Resolution:** Sensor Dependent. See Sensor Performance Data table.
- Sensor Excitation:** Constant current mode: 1mA, 100 μ A or 10 μ A.
Constant voltage mode: 10mV, 3.333mV and 1.0mV RMS. Excitation Current: 1.0mA to 10nA in steps of 5% of power.
- Resistance Measurement type:** Ratiometric bridge.
- Resistance Range:** Constant-voltage, Maximum resistance: 10mV = 1M Ω ,
3.3mV = 430K Ω , 1.0mV = 100K Ω .
- AC Excitation Frequency:** Resistor sensors in constant-voltage mode: 1.25Hz bipolar square wave.
- Sample Rate:** 10Hz per channel in all measurement modes.
- Measurement Resolution:** Sensor Dependent. See Sensor Performance Data table.
- Digital Resolution:** 24 bits.
- Measurement Drift:** <15ppm/ $^{\circ}$ C.
- Measurement Filter:** 0.5, 1, 2, 4, 8, 16, 32 and 64 Seconds.
- Calibration Curves:** Built-in curves for industry standard sensors plus four user curves with up to 200 entries each. Interpolation is performed using a Cubic Spline.
- CalGen™:** Calibration curve generator fits any diode, thermocouple or resistor sensor curve at 1, 2 or 3 user specified temperature points.
- Thermocouples:** Factory installed option on one channel only.
- Input Connector:** Universal mini-spade type thermocouple connector with screw terminals for direct connection to thermocouple wires.
- Input Range:** \pm 80mV, Resolution: 0.4 μ V.
- Electronic Accuracy:** \pm 1.0 μ V \pm 0.05%.
- Installed Types:** K, E, T and Chromel-AuFe (0.07%) plus four user supplied curves.
- Cold Junction Compensation:** Internal, enable/disable.

Control Outputs

Number of Loops: Two.

Control Input: Either sensor input.

Loop Update Rate: 10Hz per loop.

Control Type: PID table, Enhanced PID, Ramp or Manual.

Autotune: Minimum bandwidth PID loop design.

PID Tables: Two user PID tables available for storage of Setpoint vs. PID and heater range. Up to 16 entries/table.

Setpoint Accuracy: Six+ significant digits.

Fault Monitors: Control loops are disconnected upon detection of a control sensor fault or excessive internal temperature.

Over Temperature Disconnect: Heater may be relay disconnected from user equipment when a specified temperature is exceeded on any selected input.

Loop #1 Primary Heater Output

Type: Short circuit protected linear current source. Maximum compliance is 50V.

Connection: Dual Banana Plug.

Ranges: Three output ranges of 1.0A, 0.33A and 0.10A full-scale, which correspond to 50W, 5.0W and 0.5W when used with a 50 Ω load.

Load Resistance: 25 Ω or 50 Ω . Heaters down to 10 Ω can be used with the 25 Ω range.

Minimum Load: 10 Ω in 25 Ω setting, 40 Ω in 50 Ω setting.

Digital Resolution: 1.0PPM of full-scale, corresponding to 20 bits.

Readback: Heater output power, Heatsink temperature.

Loop #2 Output, Standard Model 32

Type: Voltage output, 0 to 10 Volts. Input impedance: 500 Ω .

Connection: Two-pin, 3.5mm detachable terminal block.

Digital Resolution: 1.0PPM of full-scale, corresponding to 20 bits.

Loop #2 Heater Output, Model 32B

Type: 10 Watt, short circuit protected linear current source. Maximum output is 0.4A at 25V.

Load Resistance: 62.5 Ω (10Watts), 50 Ω (8Watts), 25 Ω (4 Watts) or 10 Ω (1.6 Watts).

Digital Resolution: 1.0PPM of full-scale, corresponding to 20 bits.

Readback: Heater output power.

Status Outputs

Audible and Visual Alarms: Independent audible and visual alarms.

Status reported via Remote Interface: Sensor fault, Heater over temperature fault.

Remote Interfaces

Remote interfaces are electrically isolated to prevent ground loops.

RS-232: Serial port is an RS-232 standard null modem. Rates are 300, 1200, 4800, 9600, 19,200 and 38,400 Baud.

IEEE-488 (GPIB): Full IEEE-488.2 compliant.

Language: Remote interface language is IEEE SCPI compliant. National Instruments LabVIEW™ drivers available for all interfaces.

User Setups

Two User Setups are available that save and restore the complete configuration of the instrument.

Firmware

Internal firmware and all data tables are maintained in FLASH type memory and may be upgraded via the remote interface ports. Instrument firmware updates are available on the Internet.

General

Ambient Temperature: 25°C ± 5 °C for specified accuracy.

Mechanical: 8.5"W x 3.5"H x 12"D. One half-width 2U rack. Instrument bail standard, rack mount kit optional.

Weight: 9 Lbs.

Enclosure: Aluminum Extrusion. Machined Aluminum front and rear panels.

Power Requirement: 100, 120, 220 or 240VAC +5% -10%.
50 or 60Hz, 150VA max.

Input Channels

There are two independent, multi-purpose input channels; each of which can separately be configured for use with any supported sensor.

The Sensor Type is selected by the user via the microprocessor. Values of excitation current, voltage gain etc. will be determined by the microprocessor and used to automatically configure the channel. There are no internal jumpers or switches.

Constant-Current Sensor Excitation

Cryogenic sensors including Diode and Platinum devices require a constant-current excitation. To support this, the Model 32 has a constant-current excitation mode with three selectable outputs of 10 μ A, 100 μ A and 1.0mA DC.

The maximum compliance of the constant-current source is 2.45V.

Temperature is measured with diode type sensors by providing a 10 μ A excitation current and reading the resulting voltage.

The Model 32 uses a Ratiometric bridge technique to measure resistor sensors. Here, the measurement is the ratio between the sensor resistance and an internal calibration standard resistance. This effectively cancels the DC drift and electronic noise associated with the internal voltage reference and constant-current source circuitry.

Resistor sensors may use any of the three constant-current settings.

Constant-Voltage Sensor Excitation

A unique feature of the Model 32 is the constant-voltage excitation mode where current applied to the sensor is autoranged in order to maintain a constant RMS voltage level across the sensor.

A constant-voltage excitation is necessary since the resistance thermometers used below about 10K exhibit a negative temperature coefficient. Therefore, a constant-voltage measurement will reduce the power dissipation in the sensor as temperature decreases. By maintaining a low power levels, sensor self-heating errors that occur at very low temperatures are minimized.

In the constant-voltage mode, sensor excitation is a 1.25Hz bipolar square-wave. This provides DC offset cancellation without loss of signal energy.

Available voltage selections are 10.0mV, 3.33mV and 1.0mV RMS. The maximum and minimum sensor resistance that can be read is a function of the selected voltage bias.

Power dissipation in the sensor is computed by:

$$P_d = \frac{V_{bias}^2}{R_{sensor}}$$

Resistance Range Table		
Voltage Bias	Min. Resistance	Max. Resistance
10.0mV	10Ω	1.0MΩ
3.33mV	4Ω	250KΩ
1.0mV	1Ω	100KΩ

Table 17: Voltage Bias Selections

Excitation current sources used with constant-voltage bias are calibrated from 1.0mA to 0.1uA so that the accuracy of resistance measurement will be $\pm 0.1\%$. Accuracy will steadily degrade at lower excitation currents down to the minimum available output current of 10nA where the accuracy of resistance measurement is about $\pm 0.7\%$.

The tradeoff in measurement accuracy vs. minimum sensor excitation current is taken for two reasons:

1. The sensitivity of NTC resistor sensors is extremely high in the low temperature end of their range. Therefore the reduced measurement accuracy does not degrade temperature measurement accuracy.
2. The low current settings are required since sensor self-heating at low temperature is a very significant source of errors.

In order to minimize large jumps in self-heating, the Model 32 uses current sources to cover the 1.0mA to 10nA in steps of 5% power.

Resistance Measurement Accuracy		
Voltage Bias	$\pm 0.1\%$	$\pm 0.7\%$
10.0mV	10Ω - 100KΩ	1.0MΩ
3.33mV	3.3Ω - 43KΩ	430KΩ
1.0mV	1Ω - 10KΩ	100KΩ

Table 18: NTC Resistor Measurement Accuracy

Supported Sensor Types

A complete list of the sensor types supported by the Model 32 is shown below:

Sensor Type	Max. Voltage/ Resistance	Bias Type	Excitation Current	Typical Use
Diode	2.5V	CI	10 μ A	Silicon Diode, GaAs Diode.
ACR	1 Ω to 1M Ω	CV	1.0mA to 10nA	NTC resistors including Ruthenium Oxide, Cernox
R250K10UA	250K Ω	CI	10 μ A	NTC resistors including Ruthenium Oxide, Cernox™.
R125K10UA	125K Ω	CI	10 μ A	NTC resistors including Ruthenium Oxide, Cernox™.
R62K10UA	62K Ω	CI	10 μ A	NTC resistors including Ruthenium Oxide, Cernox™.
R16K10UA	16K Ω	CI	10 μ A	PTC/NTC Resistors.
R8K10UA	8K Ω	CI	10 μ A	PTC/NTC Resistors.
R6K100UA	6K Ω	CI	100 μ A	Platinum 1000
R2K100UA	2K Ω	CI	100 μ A	Platinum 1000
R625R1MA	625 Ω	CI	1.0mA	Pt 100 > 800K.
R312R1MA	312 Ω	CI	1.0mA	Pt 100 < 800K.
R125R1MA	125 Ω	CI	1.0mA	Rhodium-Iron
TC80	78mV	--	0	80mV thermocouple
TC40	39mV	--	0	40mV thermocouple
Snone	0	--	0	Disable Input Channel

Table 19: Supported Sensor Configurations

Bias types are:

CI – Constant Current sensor excitation.

CV – Constant Voltage sensor excitation. Voltages of 10.0mV, 3.3mV and 1.0mV RMS may be selected. Excitation current autoranges from 1.0mA to 10nA in order to maintain the selected voltage.

Silicon Diode Sensors

Silicon Diode sensors (2-volt diodes) are configured with a 10 μ A current source excitation and a 2.5 Volt unipolar input voltage range.

Gallium-Arsenide Diode Sensors

Gallium-Arsenide Diodes, or 6-Volt Diodes, can be used down to a minimum temperature of about 25K. This limitation is imposed by the fact that the controller's maximum input voltage is 2.25 Volts.

Gallium-Arsenide sensors do not fit standard calibration curves, therefore, the user must provide a sensor-specific curve before using this type sensor.

To use diodes, Gallium-Arsenide select the Diode input sensor type.

PTC Resistor Sensor (RTDs)

The Model 32 supports all types of Positive-Temperature-Coefficient (PTC) resistive sensors. Various combinations of excitation current and full-scale input voltage allow the user to trade off accuracy vs. sensor self heating.

The [Supported Sensor Configurations](#) table above gives a complete list of combinations that can be selected.

Standard calibration curves are provided for DIN43760 and IEC751 Platinum sensors. While these curves are based on a 100 Ω sensor, they may easily be extended to other resistance values by using the Multiplier field of the sensor setup.

A table of recommended setups for various types of PTC resistor sensors is shown here:

Type	Sensor Type	Sensor Excitation	TC	Calibration Units
Platinum, 100Ω	R625R1MA	1.0mA, AC/DC	(+)	Ohms
Platinum, 1000Ω	R6K100UA	100 μ A, AC/DC	(+)	Ohms
Platinum, 10KΩ, < 425K	R16K10UA	10 μ A, AC/DC	(+)	Ohms
Rhodium-Iron	R125R1MA	1.0mA, AC/DC	(+)	Ohms

Table 20: PTC Resistor Sensor Configuration

NTC Resistor Sensor Devices

The Model 32 also supports almost all types of Negative-Temperature-Coefficient (NTC) resistive sensors. Using AC, constant-voltage excitation, these sensors can be used down to extremely low temperatures.

Examples of NTC resistor sensors include: Ruthenium Oxide, Cernox™, Carbon Glass™, Germanium and Thermistors.

Calibration tables may be entered either directly in Ohms or in (base 10) Log of Ohms.

A table of recommended setups for various types of NTC resistors sensors is shown here:

Type	Sensor Type	Sensor Excitation	TC	Calibration Units
Carbon Glass™	ACR	1.0 to 10.0mV AC	(-)	LogOhm
Germanium	ACR	1.0 to 10.0mV AC	(-)	LogOhm
Cernox™	ACR	1.0 to 10.0mV AC	(-)	LogOhm
Ruthenium Oxide	ACR	1.0 to 10.0mV AC	(-)	LogOhm
Thermistors	ACR	1.0 to 10.0mV AC	(-)	LogOhm

Table 21: NTC Resistor Sensor Configuration

Thermocouple Sensors

The Model 32 can be ordered with optional thermocouple support.

Thermocouple inputs on the Model 32 feature:

- Universal thermocouple input supports all types including user-supplied.
- High accuracy built-in Cold Junction compensation.
- Open sensor detection.

For more information on using thermocouples, please refer to the sections [Thermocouple Sensor Connections](#) and [Using Thermocouple Sensors](#).

Sensor Performance Summary

Sensor Type	Silicon Diode	100Ω Platinum DIN43760	1000Ω Platinum DIN43760	10KΩ Platinum DIN43760
Input Configuration	2.5V, 10μA	625Ω, 1.0mA	3125Ω, 100μA	16KΩ, 10μA
Sensor Sensitivity	300K: 2.4mV/K 77K: 1.9mV/K 4.2K: 30mV/K	800K: 0.36Ω/K 300K: 0.39Ω/K 77K: 0.42Ω/K 30K: 0.19Ω/K	600K: 3.7Ω/K 300K: 3.9Ω/K 77K: 4.2Ω/K 30K: 1.9Ω/K	300K: 39Ω/K 77K: 42Ω/K 30K: 19Ω/K
Measurement Accuracy	300K: 21μV 77K: 23μV 4.2K: 44μV	800K: 2.4mΩ 300K: 2.4mΩ 77K: 1.2mΩ 30K: 1.2mΩ	600K: 38mΩ 300K: 38mΩ 77K: 4.7mΩ 30K: 4.7mΩ	300K: 380mΩ 77K: 50mΩ 30K: 50mΩ
Temperature Measurement Accuracy	300K: 8.7mK 77K: 12mK 4.2K: 1.6mK	800K: 6.7mK 300K: 6.2mK 77K: 2.8mK 30K: 9.8mK	600K: 6.2mK 300K: 6.2mK 77K: 2.8mK 30K: 9.8mK	300K: 6.2mK 77K: 2.8mK 30K: 9.8mK
Measurement Resolution	300K: 7.4μV 77K: 7.4μV 4.2K: 15μV	800K: 1.8mΩ 300K: 1.8mΩ 77K: 460μΩ 30K: 460μΩ	600K: 15mΩ 300K: 15mΩ 77K: 1.8mΩ 30K: 1.8mΩ	300K: 150mΩ 77K: 18mΩ 30K: 1.8mΩ
Temperature Resolution	300K: 3.0mK 77K: 3.8mK 4.2K: 500μK	800K: 5.1mK 300K: 4.7mK 77K: 1.1mK 30K: 2.4mK	600K: 4mK 300K: 4mK 77K: 0.5mK 30K: 1.0mK	300K: 4mK 77K: 0.5mK 30K: 1.0mK
Control Stability	300K: 3.0mK 77K: 3.8mK 4.2K: 500μK	800K: 5.1mK 300K: 4.7mK 77K: 1.1mK 30K: 2.4mK	600K: 4mK 300K: 4mK 77K: 0.5mK 30K: 1.0mK	300K: 4mK 77K: 0.5mK 30K: 1.0mK
Power Dissipation	4.2K: 17μW 77K: 12μW	30K: 3.7μW 77K: 20μW	30K: 370nW 77K: 2.0μW	30K: 37nW 77K: 200nW
Magneto-resistance	Very Large	Moderate	Moderate	Moderate

Table 22: Sensor Performance for Diodes and Pt Sensors.

Sensor Type	Ruthenium Oxide ²	Carbon Glass™ ²	Cernox™ ²
Example Sensor	RX102A	CGR-1-500	CX-1050
Sensor Sensitivity	1.0K: 1260Ω/K 4.2K: 80.3Ω/K 20K: 3.96Ω/K	1.4K: 520KΩ/K 4.2K: 422Ω/K 77K: 0.1Ω/K 300K: 0.01Ω/K	1.4K: 240KΩ/K 4.2K: 2290Ω/K 77K: 2.15Ω/K 300K: 0.16Ω/K
Measurement Accuracy	1.0K: 1.9Ω 4.2K: 1.4Ω 20K: 1.09Ω	1.4K: 728Ω 4.2K: 0.58Ω 77K: 14mΩ 300K: 0.02Ω	1.4K: 675Ω 4.2K: 5.1Ω 77K: 161mΩ 300K: 40mΩ
Temperature Measurement Accuracy	1.0K: 1.9mK 4.2K: 17mK 20K: 275mK	1.4K: 1.4mK 4.2K: 1.4mK 77K: 150mK 300K: 2.1K	1.4K: 2.2mK 4.2K: 2.2mK 77K: 75mK 300K: 295mK
Measurement Resolution	2.0K: 11mΩ 4.2K: 11mΩ 20K: 11mΩ	4.2K: 11mΩ 77K: 0.2mΩ 300K: 0.2mΩ	4.2K: 46mΩ 77K: 1.8mΩ 300K: 0.5mΩ
Temperature Resolution	2.0K: 32μK 4.2K: 0.13mK 20K: 2.9mK	4.2K: 30μK 77K: 1.2mK 300K: 12mK	4.2K: 50μK 77K: 0.85mK 300K: 3.5mK
Control Stability	2.0K: 0.15mK 4.2K: 0.15mK 20K: 2.9mK	4.2K: 0.15mK 77K: 35mK 300K: 250mK	4.2K: 0.15mK 77K: 0.15mK 300K: 35mK
Power Dissipation	1.0K: 42nW 4.2K: 73nW	1.4K: 962pW 4.2K: 171nW	1.4K: 1.1nW 4.2K: 20nW
Magneto-resistance	<2% for H<2T	Moderate	<1% for H<2T
² 10mV Constant-Voltage bias			

Table 23: Sensor Performance for NTC sensors.

Sensor Type	Type K ¹	Type E ¹	Type T ¹	C-AuFe .07% ¹
Input Range	80mV	80mV	40mV	40mV
Sensor Sensitivity	300K: 41 μ V/K 1500K: 36 μ V/K	300K: 61 μ V/K 1200K: 76 μ V/K	300K: 41 μ V/K 600K: 60 μ V/K	300K: 22.4 μ V/K 600K: 23.4 μ V/K
Measurement Accuracy	300K: 0.6 μ V 1500K: 6.7 μ V	300K: 0.6 μ V 1200K: 9.0 μ V	300K: 0.5 μ V 600K: 4.0 μ V	300K: 0.5 μ V 600K: 2.0 μ V
Temperature Measurement Accuracy	300K: 15mK 1500K: 190mK	300K: 11mK 1200K: 122mK	300K: 12mK 600K: 75mK	300K: 17mK 600K: 90mK
Measurement Resolution	300K: 0.5 μ V 1500K: 0.5 μ V	300K: 0.5 μ V 1200K: 0.5 μ V	300K: 0.4 μ V 600K: 0.4 μ V	300K: 0.4 μ V 600K: 0.4 μ V
Temperature Resolution	300K: 11mK 1500K: 13mK	300K: 11mK 1200K: 13mK	300K: 12mK 600K: 73mK	300K: 12mK 600K: 73mK
Control Stability	300K: 110mK 1500K: 100mK	300K: 56mK 1200K: 55mK	300K: 60mK 600K: 56mK	300K: 66mK 600K: 65mK
Magneto-resistance	Very Large	Very Large	Very Large	Very Large
¹ Includes error from internal cold junction compensation				

Table 24: Sensor Performance for Thermocouple Sensors

Factory Installed Sensors

For a listing of factory installed sensors, refer to [Appendix A](#).

CalGen Calibration Curve Generator

The CalGen™ feature is used to generate new calibration curves for Silicon Diode, Thermocouple or Platinum sensors. This provides a method for obtaining higher accuracy temperature measurements without expensive sensor calibrations.

Curves can be generated from any user-selected curve and are written to a specified internal user calibration curve area.

The CalGen™ function may be performed in the instrument by using the front panel. Alternatively, the feature is also implemented in the Model 32 utilities software.

Input Channel Statistics

Input temperature statistics are continuously maintained on each input channel. This data may be viewed in real time on the Input Channel menu, or accessed via any of the remote I/O ports.

Statistics are:

- Minimum Temperature.
- Maximum Temperature.
- Temperature Variance.
- Slope and Offset of the best-fit straight line to temperature history.
- Accumulation Time

The temperature history may be cleared using a reset command provided.

Electrical Isolation and Input Protection

The input channel measurement circuitry is electrically isolated from other internal circuits. However, the common mode voltage between an input sensor connection and the instrument's ground should not exceed $\pm 40V$.

Sensor inputs and outputs are provided with protection circuits. The differential voltage between sensor inputs should not exceed $\pm 15V$.

Thermal EMF and AC Bias Issues

DC offsets can build up in cryogenic temperature measurement systems due to Thermocouple effects within the sensor wiring. Careful wiring can minimize these effects. However, in a few systems, measurement errors induced by thermal EMFs can result in unacceptable measurement errors. These cases will require the use of an AC bias, or chopped sensor excitation, in order to remove DC offsets.

Sensor Wiring

Diode and Platinum RTD type sensors use a DC measurement scheme. Therefore, the only effective method of minimizing Thermocouple (DC) offsets is to wire temperature sensors so that connections between dissimilar metals are grouped together. For example, the connection between sensor leads and cryostat wiring should be kept close together. This way, the Thermocouple junctions formed by the connection will have equal-but-opposite voltages and will cancel each other.

Frequently, sensor leads are made from the same material as the cryostat wires. Therefore, there is no significant Thermocouple formed by this connection.

In a four-wire measurement scheme, only connections in the voltage sense lines can cause measurement errors. So, the sense wires should have adjacent contacts in a multi-pin connector in order to minimize any temperature difference between them.

Usually, the 'connection to copper' in a cryostat is made at the top of the cryostat. After this point, Thermal EMFs cannot be generated.

AC Excitation

When a sensor type of ACR, or AC Resistance, is selected, the Model 32 uses a 1.25Hz square-wave sensor excitation. This eliminates DC offsets by computing the sensor resistance at two different excitation points. This method will not work diode sensors.

Control Outputs

Control Loop #1, Primary Heater Output

The Loop #1 heater output is a short circuit protected linear current source. This output is heavily regulated and RFI filtered. External filters should not be necessary.

Automatic shutdown circuitry is provided that will protect the heater output stage from excessive temperature. Here, the heater output will be turned off until the output stage returns to its Safe Operating Area (SOA), then the output will be returned to normal operation.

Load resistance values of either 25Ω or 50Ω may be selected. Using a 25Ω load, the heater will be automatically configured to have a compliance voltage of 25V. With a 50Ω load, the compliance voltage is 50V. In either case, the maximum output current is 1.0A.

There are three output ranges, which are manually selected in PID mode and automatically selected in the PID Table control mode. The ranges are High, Medium and Low.

Range	Compliance Voltage		Full-Scale Current	Max. Output Power	
	25Ω	50Ω		25Ω	50Ω
High	25	50	1.0A	25 Watts	50 Watts
Medium	25	50	0.333A	2.5 Watts	5.0 Watts
Low	25	50	0.100A	0.25 Watts	0.50 Watts

Table 25: Loop 1 Heater output ranges.

Care must be taken to ensure that the proper load resistance is selected. Connection to a 25Ω load while a 50Ω is selected will result in overheating and eventual automatic heater shutdown. Conversely, connection to a 50Ω load while setting a 25Ω load will result in only one half of the indicated heater power being dissipated in the load.

Load resistance and Full Scale Output Range are selected via the front panel, or any of the remote interfaces.

Heater output power displays are based on the heater read-back circuitry which measures output current independently of the actual heater circuitry. Thus, heater fault conditions can be detected and their corresponding alarms asserted.

The temperature of the internal heater heat sink is continuously monitored used to generate over temperature fault conditions that will result in shut down of the control loop.

The absolute resolution of output heater current is 0.0015% of full scale (Sixteen bits). However, this resolution is significantly extended through the use of a dither signal that is applied to the Digital-to-Analog Converter and averaged by analog filtering in the output stage. The resulting output is an interpolation between the available quantization levels. See [Appendix C: Application Note on Signal Dither](#) for details.

 **Note:** Heater output displays are given as a percentage of output power, not output current. In order to compute actual output power, multiply this percentage by the full-scale power of the selected range. However, to compute actual output current, you must first take the square root of the percentage and then multiply by the full-scale current.

Connection to the heater output is made on the rear panel using the banana-plug block provided.



Caution: The Model 32 has an automatic control-on-power-up feature. If enabled, the controller will automatically begin controlling temperature whenever AC power is applied. For a complete description of this function, please see the SYS-Auto Ctl function in the [System Functions menu](#) section.

Control Loop #2, Secondary Heater Output

For a standard Model 32, control loop 2 is a voltage output with a 600 Ω output impedance. Range is zero to 10.0 Volts.

In the Model 32B, control loop 2 is a constant current source similar to the Loop 1 heater. It has a single output range of zero to 450mA and a compliance of 25V. This will result in an output power of 10 Watts into a 50 Ω load.

The absolute resolution of Loop 2 is 0.0015% of full scale (Sixteen bits). However, this extended through the use of a dither signal. See [Appendix C: Application Note on Signal Dither](#) for details.

Connection to the Analog Output is made on the rear panel using the pluggable terminal block provided.

Control Types

There are four control types available in the Model 32. They are Manual, PID, PID Table and Ramp. All modes are available on both control loops.

Manual mode operation allows setting the output power manually as a percentage of full-scale power.

PID control allows feedback control using an enhanced PID algorithm that is implemented using 32-bit floating point Digital Signal Processing techniques. Enhancements include:

1. Implementation of a user settable damping factor that can be used to minimize overshoot to a new setpoint without affecting the PID loop operation.
2. Noise filtering on the derivative term. The D term will provide better control stability, but is often not used because, without filtering, it can make the control loop too sensitive to noise.
3. Integrator wind up compensation. While slewing to a new setpoint, the integrator in the PID loop can build up to a very large value. If no compensation is applied, overshoot and time to stability at the new setpoint can be delayed for an extremely long time. This is especially true in cryogenic environments where process time constants can be very long.
4. Dithering and filtering the outputs in order to increase output resolution and improve control stability.

The PID Table control mode is a PID control loop just as described above. However, it is used to look up P,I,D and heater range values based on the specified setpoint. This is useful where a process must operate over a wide range temperature range since optimum PID values usually change with temperature.

To use the Table mode effectively, the user must first characterize the cryogenic process over the range of temperature that will be used, then generate PID and heater range values for various temperature zones. This is usually done using the autotune capability. Once the information is placed into a PID Table, the Model 32 will control in Table mode by interpolating optimum PID values based on setpoint.

The Model 32 allows for the entry of four independent PID Tables. Each table may contain up to 16 temperature zones.

In the Ramp control mode, the controller will approach a new setpoint at a user specified rate. When this setpoint is reached, the controller will revert to PID control.

Alarm Outputs

Alarm outputs include a LED indicator, an audible alarm, on-screen display and remote reporting.

Alarms may be asserted based on high temperature, low temperature, input sensor fault or heater fault conditions.

There is a 0.25K hysteresis built into the high and low temperature alarms.

Remote Interfaces

IEEE-488.2 and RS-232 interfaces are standard. All functions and read-outs available from the instrument may be completely controlled by any of these interfaces.

The Serial port is an RS-232 standard null modem with male DB9 connector. Rates are 300, 1200, 4800, 9600, 19,200 and 38,400 Baud.

The GPIB is fully IEEE-488.2 compliant. Connection is made at the rear panel using the IEEE-488 standard connector.

The programming language used by the Model 32 is identical for all interfaces and is SCPI language compliant. The Standard Command Protocol for programmable Instruments (SCPI) is a sub section of the IEEE-488.2 standard and is a tree structured ASCII command language that is commonly used to program laboratory instruments.

Rear Panel Connections

The rear panel of the Model 32 is shown here:

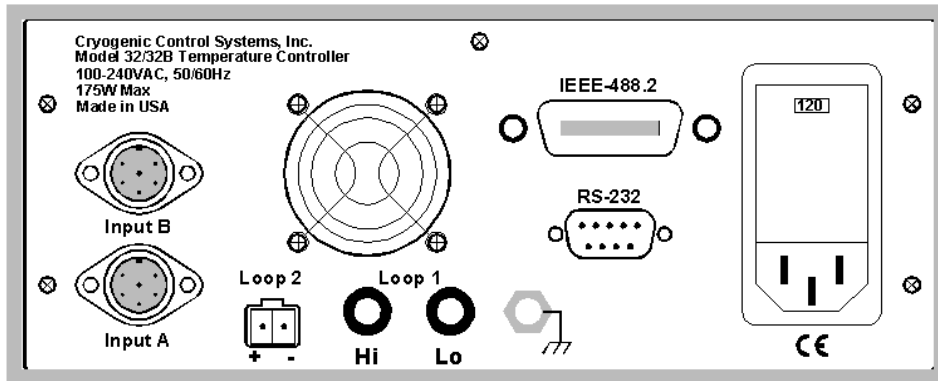

Figure 3: Model 32 Rear Panel Layout

AC Power Connection

The Model 32 requires single-phase AC power of 50 to 60 Hz.



Caution: Protective Ground: To minimize shock hazard, the instrument is equipped with a three-conductor AC power cable. Plug the power cable into an approved three-contact electrical outlet or use a three-contact adapter with the grounding wire (green) firmly connected to an electrical ground (safety ground) at the power outlet.

The power jack and mating plug of the power cable meet Underwriters Laboratories (UL) and International Electrotechnical Commission (IEC) safety standards.

User-replaceable fuses are incorporated in the Power Entry Module.

Fuse Replacement and Voltage Selection

Access to the Model 32's fuses and voltage selector switch is made by using a screwdriver to open fuse drawer in the power entry module. A slot is provided above the voltage selector window for this purpose.

The fuse and voltage selection drawer cannot be opened while the AC power cord is connected.

Voltage selection is performed by rotating the selector cams until the desired voltage shows through the window shown.

There are two fuses that may be removed by pulling out the fuse modules below the voltage selector. Fuses are specified according to the AC power line voltage used:

Line Voltage	Fuse	Example
100VAC, 120VAC	2.0A slow-blow	Littlefuse 313 002
220VAC, 240VAC	1.0A slow-blow	Littlefuse 313 001

Table 26. AC Power Line Fuses

Sensor Connections

All sensor connections are made at the rear panel of the Model 32 using the two DIN-5 receptacles provided.

Standard Four Wire Sensor Connections

Silicon Diode and all resistor type sensors should be connected to the Model 32 using the four-wire method. It is strongly recommended that sensors be connected using shielded, twisted pair wire. Wires are connected as shown below and the shield should be connected to the metal backshell of the connector.

Pin	Function
1	Excitation (-), I-
2	Sense (-), V-
3	Do not connect
4	Sense (+), V+
5	Excitation (+), I+

Table 27: Input Connector Pin-out



Caution: To ensure proper low noise operation, cable shields should be connected to the metal backshell of the connector. A metal clip is provided with the connector for this purpose. Please refer to the section on shielding and grounding for further information.

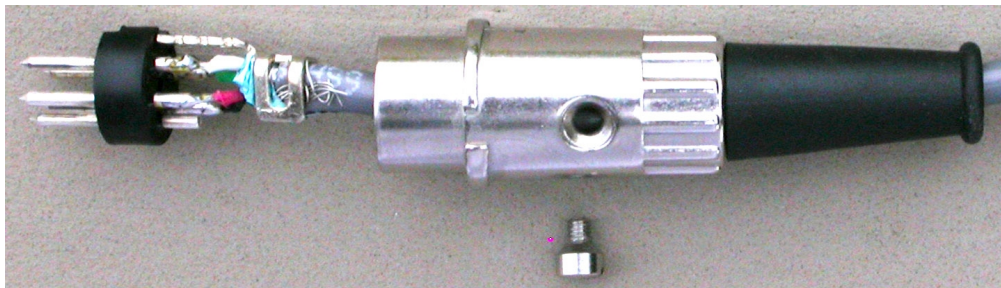

Figure 4: Proper Assembly of the Input Connector

Note: The input connectors on the Model 32 will mate with either DIN-5 or DIN-6 plugs. Wiring is identical. If a DIN-6 plug is used, Pin 6 is not connected. Do not connect to pin 3 of either connector.

Recommended color codes for a sensor cable are as follows:

Color Code	Signal	Pin
White	Excitation(+)	5
Green	Excitation(-)	1
Red	Sense(+)	4
Black	Sense(-)	2

Table 28: Dual Sensor Cable Color Codes

The cable used is Belden 8723. This is a dual twisted pair cable with individual shields and a drain wire. The shields and drain wire are connected to the DIN-5's connector's metal backshell in order to complete the shielding connection.

A four-wire connection is recommended in order to eliminate errors due to lead resistance. Cryogenic applications often use fine wires made from specialty metals that have low heat conduction. This results in high electrical resistance and, therefore, large measurement errors if the four-wire scheme is not used.

Four-wire connection to Diode and Resistive type sensors is diagrammed below:

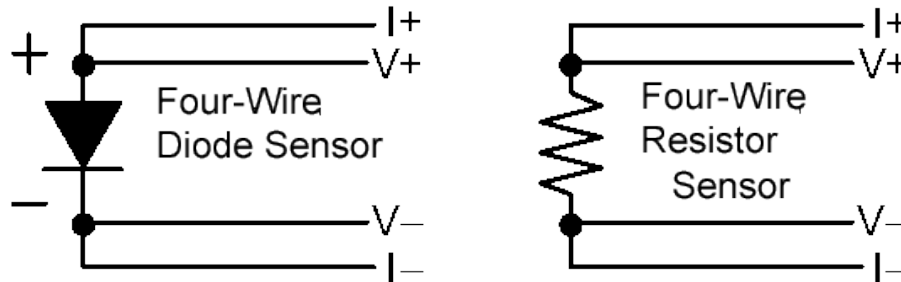

Figure 5: Diode and Resistor Sensor Connections

Cryo-con S700 Silicon Diode Connections

The S700BB is a Silicon Diode temperature sensor. Connection is made using a color-coded four-wire, 36 AWG cryogenic ribbon cable.

Wires may be separated by dipping in Isopropyl Alcohol and then wiping clean.

Insulation is Formvar™ and is difficult to strip. Techniques include use of a mechanical stripper, scraping and passing the wire over a low level flame.

Ribbon Cable Color Codes	
V+	Clear
V-	Green
I+	Black
I-	Red

Thermocouple Sensor Connections

Thermocouple sensors require the factory installed thermocouple option. All thermocouple connections must be made at the sensor input connector since this connector is thermally anchored to an internal sensor that is used for Cold Junction compensation.

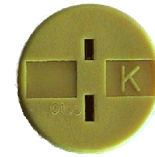

Thermocouple sensors are connected to the Model 32 by use of the special connector provided with the controller. Sensor connection is made at the screw terminals. Proper polarity of the sensor wires is required. Polarity is marked on the input connector and a summary of common thermocouple polarities is given in the table below. The input connector should have its backshell and rubber grommet installed in order to prevent local air currents from generating errors in the cold junction circuitry.

It is recommended that the Thermocouple sensor be electrically isolated, or floating, from any surrounding circuits or grounds. This will ensure the highest possible measurement accuracy.

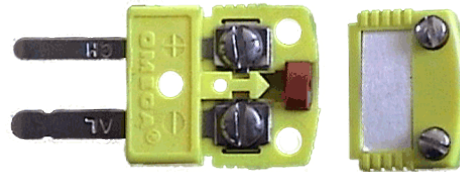

Figure 6: Thermocouple Input Connector

Additional discussion on Thermocouple and grounding issues can be found below in the [“Using Thermocouple Sensors”](#) section below.

Type	Color	(+) Terminal	(-)Terminal
E	Purple	Chrome	Constantan
K	Yellow	Chrome	Aluminum
T	Blue	Copper	Constantan
U	White	Copper	Copper

Table 29: Thermocouple Types

Loop #1 Heater Connections

Rear panel Primary Heater Output (Loop #1) connections are made using the two-pin banana plug shown here. Pin One of this block (HI) is the positive output and Pin Two (Lo) is the ground return. The shield of the output cable should be connected to the third (uninsulated) banana plug.

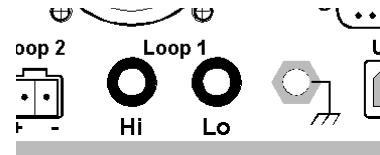

Loop #2 Output Connections

Rear panel connections to the Loop #2 output are made using the two-pin pluggable 0.200" terminal block shown above. Pin One of this block (left hand pin) is the positive (+) output and Pin Two is the return (-). The shield of the output cable may be connected to Pin Two.

The two-pin heater terminal block plug is an Augat part number 2ESDV-02. It is available from Cryo-con as part number 04-0301.

IEEE-488.2 Connections

Rear panel connection to the IEEE-488.2 is performed using the GPIB connector.

GPIB cables are available in various lengths. However, only shielded type assemblies should be used. Many of the molded GPIB cables are actually unshielded and can introduce excessive noise into your instrumentation environment.

RS-232 Connections

The Model 32 uses a Female DB-9 connector for RS-232 serial communications. The pin-out of this connector is as follows:

Pin	Function
1	NC
2	RXD, Receive data
3	TXD, Transmit data
4	NC
5	Ground
6	NC
7	NC
8	NC
9	NC

Table 30: RS-232 DB-9 Connector Pinout

The cable used to connect the Model 32 to a computer serial port is a Dual Female Null Modem cable. An example is Digikey Inc. part number AE1033-ND.

The wiring diagram for this cable is shown below. Note that communication with the Model 32 only requires connection of pins 2, 3 and 5. All other connections are optional.

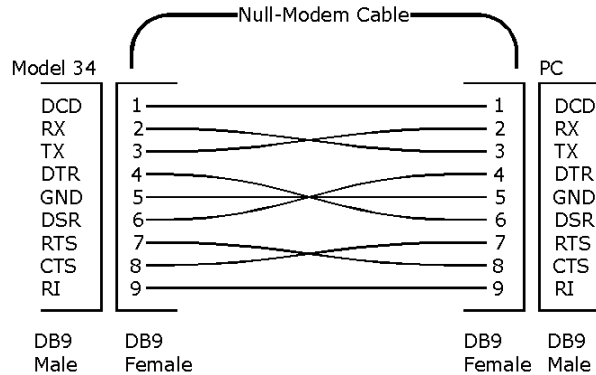

Figure 7: RS-232 Null Modem Cable

Mechanical, Form Factors and Environmental Display

The display is a two line by twenty-character dot matrix VFD.

Enclosure

The Model 32 enclosure is standard 2-U half-width 17-inch rack-mountable type that may be used either stand-alone or incorporated in an instrument rack.

Dimensions are: 8.5"W x 3.5"H x 12"D. Weight is 9 Lbs.

An instrument bail and feet are standard. Rack Mount kits are available from Cryo-con for both single instrument or side-by-side dual configurations. A rack mount kit is optional.

AC Power

The Model 34 requires single-phase AC power of 50 to 60 Hz. Voltages are set by the line voltage selector in the Power Entry Module on the rear panel.

Line voltage selections are: 100, 120, 220 or 240VAC. Tolerance on voltages is +10% to -5% for specified accuracy and -10% for reduced full-scale heater output in the highest output range.

Protective Ground: To minimize shock hazard, the instrument is equipped with a three-conductor AC power cable. Plug the power cable into an approved three-contact electrical outlet or use a three-contact adapter with the grounding wire (green) firmly connected to an electrical ground (safety ground) at the power outlet.

The power jack and mating plug of the power cable meet Underwriters Laboratories (UL) and International Electrotechnical Commission (IEC) safety standards.

Power requirement is 25 Watts plus the power being provided to the heater load.

The power cord will be a standard detachable 3-prong type.

User-replaceable fuses are incorporated in the Power Entry Module. See the section titled Fuse Replacement / Voltage Selection.

 **Note:** The Model 32 uses a smart power on/off scheme. When the power button on the front panel is pressed to turn the unit off, the instrument's setup is copied to flash memory and restored on the next power up. If the front panel button is not used to toggle power to the instrument, the user should configure it and cycle power from the front panel button one time. This will ensure that the proper setup is restored when AC power is applied.













Environmental and Safety Concerns.

Safety

The Model 32 protects the operator and surrounding area from electric shock or burn, mechanical hazards, excessive temperature, and spread of fire from the instrument.

- **Keep Away From Live Circuits:** Operating personnel must not remove instrument covers. There are no internal user serviceable parts or adjustments. Refer instrument service to qualified maintenance personnel. Do not replace components with power cable connected. To avoid injuries, always disconnect power and discharge circuits before touching them.
- **Cleaning:** Do not submerge instrument. Clean exterior only with a damp cloth and mild detergent only.
- **Grounding:** To minimize shock hazard, the instrument is equipped with a three-conductor AC power cable. Plug the power cable into an approved three-contact electrical outlet only.

Safety Symbols

	Direct current (power line).		Equipment protected throughout by double insulation or reinforced insulation (equivalent to Class II of IEC536).
	Alternating current (power line).		Caution: High voltages; danger of electric shock. Background color: Yellow; Symbol and outline: Black.
	Alternating or direct current (power line).		Caution or Warning - See instrument documentation. Background color: Yellow; Symbol and outline: Black.
	Three-phase alternating current (power line).		Fuse.
	Earth (ground) terminal.		
	Protective conductor terminal.		
	Frame or Chassis terminal.		
	On (AC Power)		
	Off (AC Power)		

Environmental Conditions

Environmental conditions outside of the conditions below may pose a hazard to the operator and surrounding area:

- Indoor use only.
- Altitude to 2000 meters.
- Temperature for safe operation: 5 °C to 40 °C.
- Maximum relative humidity: 80% for temperature up to 31 °C decreasing linearly to 50% at 40 °C.
- Power supply voltage fluctuations not to exceed $\pm 10\%$ of the nominal voltage.
- Over voltage category II.
- Pollution degree 2.
- Ventilation: The instrument has ventilation holes in its side covers. Do not block these holes when the instrument is operating.
- Do not operate the instrument in the presence of flammable gases or fumes. Operation of any electrical instrument in such an environment is a definite safety hazard.

Basic Setup and Operating Procedures.

Configuring a sensor

Before connecting a new sensor to the Model 32, the instrument should be configured to support it. Most common sensors are factory installed; others require a simple configuration sequence.

A complete list of sensors installed at the factory is shown in [Appendix A](#). To configure the instrument for one of these sensors, proceed as follows:

1. To install the sensor on Input Channel A, press the **ChA** key. For Channel B, press the **ChB** key. This will take you to the Input Channel Setup menu for the selected channel. The first line of this display will show the current temperature in real-time and allow you to select the desired display units. Press the **▶** or **◀** keys to sequence through the available options and press the **Enter** key to make the selection.
2. Press the **▼** key to go down to the Sen: filed. Here, you will use the **▶** or **◀** key to scroll through all of the sensor types available. When the desired sensor is displayed, press the **Enter** key to configure the instrument.

Select **None** to disable the input channel.

At the end of the factory-installed sensors, four user-installed selections will be shown. The default name for these is User Sensor N. However, this name can be changed to give a better indication of the sensor type that is connected.

For most sensor types, installation is now complete and the Home key can be pressed to return to the Home Status display. The exceptions are NTC resistor sensors that use constant-voltage AC excitation. With these types of sensors, you will need to scroll down to the Bias Voltage field and select the desired constant-voltage excitation level.

 **Note:** NTC resistor sensors require the selection of a Bias Voltage. Selections are 10mV, 3.3mV and 1.0mV. Generally, 10mV works well for most sensors down to about 1K. Below that, the lower settings may be used to minimize errors from sensor self-heating. However, use of a lower voltage limits the maximum resistance range and significantly increases measurement noise.

Once sensor configuration is complete, review the section on [Sensor Connections](#) to connect the sensor to the instrument.

Adding a New Sensor Type

This procedure identifies how to add a new sensor type to the controller. If the desired sensor is already installed as a factory installed sensor or previously installed user sensor, this procedure is not required. These sensors can be simply assigned to an

input channel by using the [Input Channel Setup Menu](#) described above.

Adding a new sensor to the Model 32 is a two-step process. First, the sensor type must be defined using the [Sensor Setup Menu](#). Next, the sensor's calibration curve must be entered by using the [Calibration Curve Menu](#).

Note that, if the new sensor has a lengthy calibration curve, entry from the front panel may be tedious. In these cases, the user may consider entering the sensor via the remote interfaces using the controller's utility software.

To add a sensor using one of the remote interfaces, please refer to the Remote I/O section command syntax etc.

Sensor Setup

Sensor Setup Menu		
1	18>User Sensor 3	↩
2	18>Type: R39R1MA	↩
3	18>Mult: -1.0	#
4	18>Units: Volts	↩
5	18>Edit Cal Curve	■

Table 31: Sensor Setup Menu

The new sensor type is defined using the Sensor Setup Menu. The first line of this menu includes the Sensor Index (18) and the name (User Sensor 3). This line may be scrolled through all of the available sensor types, including factory-installed sensors. Press **Enter** to select the displayed sensor.

In order to install a new sensor, one of the four user sensors should be selected.

Next, the Type of sensor must be defined. Choices include Silicon Diodes, various resistors and thermocouples. This selection will identify the excitation current and voltage input range that the controller must use to interface with the sensor. Selections are given in Table 2 above.

The Multiplier field specifies a multiplier that is applied to the sensors calibration curve. The sign of this field indicates the temperature coefficient. This coefficient is only used when the user is attempting to control on sensor units, such as Ohms or Volts.

Most commonly, the multiplier field contains a value of plus or minus 1.0. This causes the controller to apply the sensor calibration curve directly, without first scaling it. Further, a negative value will indicate that the sensor has a negative temperature coefficient and a positive value will indicate a positive coefficient.

Diode sensors will generally have a Multiplier of -1.0 since their temperature coefficient is negative and no scale is applied to the calibration curve.

100 Ω Platinum sensors will use a Multiplier of 1.0. However, if a 1000 Ω sensor is used with a calibration curve for 100 Ω sensors, a Multiplier of 10.0 should be used.

'Units' is an enumeration field that identifies the basic units used by the sensor's calibration curve. Choices are Volts, Ohms and LogOhm. LogOhm selects the base ten logarithm-of-ohms and is useful with sensors whose fundamental resistance vs. temperature curve is logarithmic.

The LogOhm selection is only used with Negative-Temperature-Coefficient resistor sensors, where it acts to improve the accuracy of interpolation.

The N field is the number of valid points in the calibration curve and is generated from the entries made during the editing process.

Selecting the 'EDIT CAL CURVE' field will cause the screen to go to the Calibration Curve menu for the selected sensor. Here, the calibration curve may be entered or edited.

Calibration Curve Entry

Once a sensor type is defined, the calibration curve for that sensor may be entered. This may be done by using the [Calibration Curves Menu](#) described above, or, using any of the remote I/O ports, or using the Model 32 Utility Software package.

One very efficient way to enter a new calibration curve is to use the instrument's CalGen™ feature to generate a new curve from an existing one. Operation of this feature is described below.

Autotuning

The Autotune Process

The Model 32 performs autotuning by applying a generated waveform to the heater output and analyzing the resulting changes in process temperature. This is used to develop a process model, then a PID solution.

It is important to note that there is a range of PID combinations that will provide accurate control for a given process. Further, process modeling is a statistical method that is affected by noise and system non-linearity.

As a result, multiple autotuning of the same process may yield different results. However, if the process model has not corrupted, any of the generated results will provide equally stable temperature control.

For further explanation, the different PID solutions generated by autotuning will vary only in the resultant closed loop bandwidth. Low bandwidth solutions will be slower to respond to changes in setpoint or load disturbances. High bandwidth solutions will result be responsive but can exhibit overshoot and damped oscillation.

The Model 32 attempts to generate minimum overshoot solutions since many cryogenic temperature control applications require this. If the process is noisy, bandwidth will be minimized as much as possible. If the process is very quiet, a more aggressive solution will be generated subject to the minimum overshoot requirement.

The autotune algorithm will produce a heater output waveform in order to force the process model to converge. In general, a large amplitude waveform will provide the best possible signal-to-noise ratio, resulting in a faster and more accurate solution.

However, it is important in some systems that the user constrains the amplitude and duration of the heater output waveform by using the DeltaP and Timeout parameters.

Small values for DeltaP will force the use of small changes in heater power. This will make the process model more susceptible to corruption by noise.

Large values of DeltaP will allow the use of large heater power swings, but this may also drive the process into non-linear operation, which will also corrupt the tuning result. Worse, it may allow application of too much heater power and may cause an over temperature condition.

Experience indicates that most cryogenic systems will autotune properly using a DeltaP of 10% whereas a noisy system will require 20% or more. A common example of a noisy cryogenic system is one where a Silicon Diode sensor is used with a setpoint near room temperature.

System Noise and Tuning Modes

Three modes of autotuning may be selected. They are: P only, PI and PID.

Using P only autotuning will result in the maximum value for P that will not cause oscillation. The process temperature will stabilize at some point near the setpoint.

Using PI or PID control will result in stable control at the setpoint.

The Derivative, or D, term in PID is used to make the controller more responsive to changes in setpoint or thermal load. It does not affect the control accuracy when the system has stabilized. However, derivative action, by its nature, amplifies noise. Therefore, PID autotuning and control should only be used with very quiet systems. PI control should be used with all others.

Sensor type has a significant impact on measurement noise.

The Model 32 uses a ratiometric technique to measure resistor sensors such as Thermistors, Platinum RTDs, Carbon Glass™ etc. This effectively cancels most of the measurement noise and allows effective use of PID control.

Voltage mode sensors, which include diodes and thermocouples, cannot benefit from ratiometric measurement, Therefore, PI control is recommended.

It is a very common mistake to attempt PID control using a Diode sensor above 70K. This is the least sensitive region of the sensor so measurement noise is very high. PI control is recommended.

Below about 20K, the sensitivity of the Diode increases significantly and PID control may be used effectively.

Pre-Tuning and System Stability.

Before autotuning can be initiated by the controller, the system must be stable in terms of both temperature and heater output power. This requires the user to perform a basic pre-tuning operation before attempting the first autotune.

The goal of pre-tuning is to stabilize the process at a temperature near the desired setpoint so that the tuning algorithm can use this as a baseline to model the process.

Cryogenic systems will usually require different PID values at different setpoint temperatures. Therefore, the pre-tuning process should result in a temperature near the desired setpoint.

Pre-tuning does NOT require that the user establish stable control at the target setpoint. This is the job of the autotuning algorithm and is much more difficult than the stability required by pre-tuning.

One method of pre-tuning is to use PID control with a small initial value for P and zero for I and D. This will result in stability at a temperature of the setpoint minus some constant offset. Increasing the P value will reduce the offset amount. When P is too large, the system will oscillate.

Another pre-tuning technique is to Manual control mode with some fixed value of output power. When the system becomes stable at a temperature corresponding to the set heater power level, a system characterization process is performed using that temperature as an initial setpoint.

System Characterization.

System characterization is the process of using autotune to generate optimal PID coefficients for each setpoint over a wide range of possible setpoints.

The characterization process is performed once. Then, the setpoints and corresponding generated PID values are transferred to an internal PID table. Thereafter, the system is efficiently controlled by using the Table control mode.

Autotune Setup and Execution

The Autotune menu for either control loop is accessed by pressing the **Auto Tune** key from the Home Operate Screen.

Upon entry, the autotune state variable will be set to Idle and the P, I and D fields on the bottom of the display will be blank.

As described above, various setup conditions must be met before autotune can be performed:

1. The Model 32 must be in Control mode.
2. Both the output power and the process temperature must be stable. The user must stabilize the process before the autotune function can accurately model it. If the process is not stable, erroneous values of P, I and D will be generated.
3. The input control channel units must be in temperature, not sensor units of Volts or Ohms. This is because PID control is a linear process and sensor output is generally non-linear. Note that the Model 32 can be manually tuned using sensor units but autotuning cannot be performed.

Autotune Menu		
1	Autotune: Loop 2	Sets the loop number for autotuning. Each control loop must be tuned separately. Choices are Loop 1 and Loop 2. The selected loop is displayed in all following lines of this menu.
2	AT-DeltaP: 20%	Sets the maximum power delta allowed during the tuning process. Value is a percent of full-scale output power for the selected loop.
3	AT-Mode: PI-	Sets autotuning mode. Choices are P, PI or PID. PI is recommended for most systems.
4	AT-Timeout: 180S	Sets the autotune timeout in seconds. If the process model has not converged within this time, tuning is aborted.
5	308.112K	Real-time display of the temperature on the input channel being tuned.
6	AT- GO	Pressing Enter will initiate the autotune sequence.
7	AT-Idle	Autotune status. Display only
8	AT-P=	Proportional gain term generated by autotune. This field will be blank until a successful autotune is completed.
9	AT-I=	Integral gain term generated by autotune. This field will be blank until a successful autotune is completed.
10	AT-D=	Derivative gain term generated by autotune. This field will be blank until a successful autotune is completed.
11	AT-Save & Exit	Pressing Enter cause the controller to transfer the generated PID coefficients to the selected loop, initiate control with the new parameters and exit to the Home Operate Display.

Table 32: Autotune Menu

The Delta P field is in percent and is the maximum change in output power that the controller is allowed to apply during the modeling process. A value of 100% will allow use full-scale power increments. A value of 20% will use a maximum power increment of $\pm 20\%$ of the current heater output.

The Mode field tells autotune to generate coefficients for P only, PI only, or PID. Choices are: P--, PI- and PID.

The Timeout field is in units of Seconds and indicates the maximum period of time that the process model will run before aborting. This value should be set to at least two or three times the estimated maximum time constant of the process.

 **Note:** Depending on the setup configuration, the autotune algorithm may apply full-scale heater power to the process for an extended time. Therefore, care should be taken to ensure that autotune does not overheat user equipment. If overheating is a concern, the Over Temperature Disconnect Monitor should be configured to disconnect the heater and abort the autotune process when an input temperature exceeds the specified maximum.

The autotune sequence is initiated by selecting the Go field. If the initialization of process modeling is successful, the status display line will change from idle to Running. If initialization is not successful, one of the above listed conditions has not been met.

When the tuning process is successfully completed, a status of Complete will be indicated and the values of P, I and D will be updated with the generated values. To accept these values and save them as the loop PID coefficients, select the Save&Exit field. To reject the values and exit, press the **ESC** key.

Autotune may always be aborted by pressing the **ESC** key.

An unsuccessful autotune will be indicated by one of the following status lines:

1. Failed. This indicates that the process model did not converge or that PID values could not be generated from the result.
2. Aborted. Autotune was aborted by user intervention such as pressing the Stop key.

Temperature Ramping

Operation

The Model 32 will perform a temperature ramp function using a specified ramp rate and target setpoint. Once placed in a ramping control mode, a ramp is initiated by changing the setpoint. The unit will then progress to the new setpoint at the selected ramp rate. Upon reaching the new setpoint, ramp mode will be terminated and standard PID type regulation will be performed.

Ramping may be independently performed on control loop.

The procedure for temperature ramping is as follows:

1. Set the Ramp Rate in the Heater Configuration Menu. This parameter specifies the ramp rate in Units Per Minute, where Units are the measurement units of the input channel controlling the heater. For example, if the input channel units are Kelvin, the ramp rate is in K/min.
2. Select a ramping Control Mode. There are two types: 1) RampP, which will perform a ramp using the current PID parameters, and 2) RampT, which will ramp using PID parameters derived from a specified PID Table. The RampP mode will perform a ramp, and then perform temperature regulation using the standard PID mode. The RampT function will perform a ramp, then perform regulation using the PID Table control mode.
3. Press CONTROL. Now, the controller will begin temperature regulation at the current setpoint.
4. Enter a new setpoint. The controller will enter ramping mode, and ramp to the target setpoint at the specified rate.
5. When the new setpoint is reached, ramping mode will terminate and temperature regulation will begin at the new setpoint.
6. Entry of a different setpoint will initiate another ramp.

As a variation on the above procedure:

1. The controller may be regulating temperature in any available control mode. This mode can be changed to a ramping mode without exiting the control loop. This will not result in a 'glitch' in heater output power.
2. Once a ramp mode is selected, ramping is performed, as above, by changing the setpoint.

The current status of the ramp function may be seen on the Operate Screen. When a ramp is active, the word RMP will appear in the control loop status displays. It may also be queried via any of the remote ports using the LOOP 1:RAMP? Command.

Ramping Algorithm

The ramp algorithm uses a basic PID type control loop and continuously varies the setpoint until the specified temperature is reached. This means that the PID control loop will continuously track the moving setpoint. The result is that there will be small time lag between the target ramp and the actual temperature.

Although not normally a problem, the ramp time lag may be minimized by using aggressive PID values. This is accomplished by increasing P, decreasing I and setting D to zero.

Ramping Parameters and Setup

The Ramp Rate is set on the Control Loop Setup menu. Note that the ramp rate on Loop 1 is independent of the rate on Loop 2.

A ramping control mode must also be set. Ramping modes are RampP or RampT. These modes are also selected in the Control Loop Setup menu.

Summary

To perform a temperature ramp, proceed as follows:

1. Set the control loop P, I and D parameters to allow stable control at both ends of the desired ramp. This is usually done by using 'slow' PID values (Low values for P, high for I and zero for D).
2. Set the Ramp Rate in the Heater Configuration Menu. Set the setpoint to the starting value for the ramp.
3. Press CONTROL. Now, the controller will begin temperature regulation at the current setpoint.
4. Enter a new setpoint. The controller will enter ramping mode, and ramp to the target setpoint at the specified rate. The word RMP will appear in the control loop menu.
5. When the new setpoint is reached, ramping mode will terminate and temperature regulation will begin at the new setpoint.

Cryocooler Signature Subtraction

Cryocoolers often have a thermal signature that is associated with the mechanical cooling process. At the low end of their temperature range, this signature can have amplitudes of one or more Kelvin.

Since the thermal signature is related to the mechanical cooling process, it is low frequency and has an irregular shape that is rich in harmonics. With most coolers, the frequency will be a sub-multiple of the AC line frequency around 2Hz and the shape will be a narrow spike followed by a long lull.

If a conventional PID control loop is connected to a cryocooler, the thermal signature will disrupt the loop and degrade the accuracy of control. If a fast PID loop is used, it will attempt to track the signature, which usually results in placing a waveform on the loop output heater that causes control performance to degrade even further.

In still other systems, the thermal signature of the cryocooler will be outside of the PID control loop bandwidth enough to cause a phase reversal that actually amplifies the signature causing the entire system to become unstable. These systems will oscillate with a sine-wave at a very low frequency.

Faced with a significant thermal signature, users are generally required to de-tune the PID loop and live with the resulting inaccurate control. Here, there is still the possibility of instability.

The Model 32 uses digital time-synchronous filter to actively subtract the cooler's signature, resulting in much higher control accuracy and loop responsiveness.

With the Synchronous Filter enabled, the controller will synchronously subtract the thermal signal from the input temperature signal. Since synchronous subtraction is used to eliminate the undesired signature, there is no phase-shift or loss of signal energy, as would be the case if a classical notch or low-pass filter is used.

Subtraction is performed ahead of the PID control loop. Therefore, the input to the loop contains only the baseline temperature signal.

Using the Input Signature Subtraction filter gives much higher temperature measurement accuracy and allows the use of aggressive, high precision control. It is applicable to virtually any cryocooler system.

Synchronous Filter Setup

To use the synchronous filter, two parameters must be set:

- The AC Line Frequency setting must correspond to the actual power input AC frequency. The filter uses this to synchronize to the cooler.
- The Synchronous Filter Taps parameter must be set for the specific cryocooler type. This parameter gives the filter a starting point for the number of filter taps required to perform an accurate subtraction. Determination of a proper setting may require some experimentation.

To set the AC Line Frequency, go to the **Sys** menu and scroll down to the field *AC Line* field. Then, select 60 or 50 Hz as required.

Sync Filt. Taps: 07# AC Line: 60Hz

To set the Synchronous Filter Taps parameter, enter a number between 1 and 25 into the *Sync Filt. Taps* field. A setting of 1 turns the filter off.

For most cryocoolers, a setting of 7 is used since this is the most common sub-multiple of the AC line frequency used.

Note: If you are not using a cryocooler, please leave the *Sync Filt. Taps* field set at the default of 7.

Note: If you change the setting the *Sync Filt. Taps* setting, you will need to re-tune the PID control loop.

Viewing a Cryocooler Thermal Signature

In order to view a cryocooler's thermal signature and experiment with the synchronous filter, the Cryo-con Utility Software may be used.

In the Data Logging menu, set the *interval* field to the minimum allowed value of 0.1 Seconds and then open a strip chart. Use the manual settings on the strip-chart to zoom in on the temperature. You should be able to see the signature with the chart set to the base temperature plus or minus about 0.5K.

In order to see the cooler signature, you will need to set the *Sync Filt. Taps* field to zero. This will disable the removal of the signature. From here, you can enter various values in order to see the affect of the synchronous filter.

Shown here is an example of a Cryomech PT403 pulse-tube refrigerator with a very low heat-capacity load. The first part of the graph is with the synchronous filter turned off and the second part shows a setting of 7 taps.

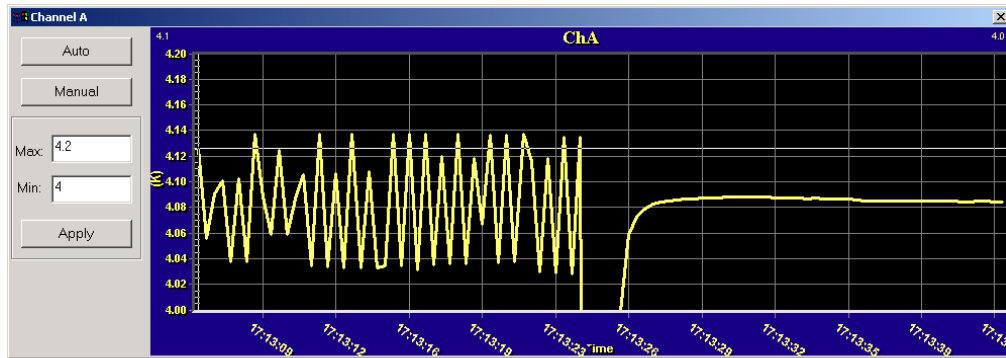

In most cases, a tap setting may be found that completely eliminates the signature.

Using an external power booster

Some systems require more power than the Model 32 can provide, or require a higher power secondary control loop. An auxiliary DC power supply or amplifier can be used for this purpose.

Programmable power supplies that can be programmed by an input voltage or current can be interfaced to either control loop of the Model 32.

Both control loops of the Model 32B are unipolar current source outputs. This means that they will not have the 'zero voltage' drift problems that bipolar voltage source outputs exhibit.

Since both loops are current-source outputs, a programming resistor may be required to develop the voltage needed by the booster supply.

To use a booster supply with the Loop #1 output, setup the controller as follows:

1. Set the Loop 1 Load Resistance to 25Ω by using the [Heater Configuration Menu](#).
2. On the [Heater Setup Menu](#), set the Heater Range to Low. This will cause the loop to output a full-scale programming current of 0.1A.
3. If the booster supply requires a voltage input, the loop output will need a programming resistor to set the full-scale programming voltage. This resistor can be installed across the input terminals of the power supply.
4. Connect the Loop #1 output to the booster supply to the programming input of the booster supply and set up the supply according to the manufacturer's documentation.

Example: Many programmable power supplies require a zero to 10 Volt programming voltage. The value of the programming resistor is:

$$R = 10\text{-Volts} / 0.1\text{mA} = 100 \text{ Ohms.}$$

Also note that the resistor must be capable of dissipating power:

$$\text{Watts} = 10\text{-Volts} * 0.1\text{mA} = 1.0\text{-Watts.}$$

Using a booster supply with Loop #2 of a Model 32 is simple since the loop outputs 0 to 10-Volts and can be connected directly to most programmable power supplies. However, Loop #2 of a Model 32B is more difficult since it is designed to output 10-Watts.

To use a booster supply with the Loop #2 of the Model 32B setup as follows:

1. Loop #2 of a Model 32B outputs 450mA at up to 25-Volts. Therefore, to generate a zero to 10-Volt output, you must use a 25-Ohm programming resistor that can dissipate at least 10-Watts. Therefore, this resistor will get very hot during normal operation.
2. Connect the Loop #2 output to the booster supply's programming and set up the supply according to the manufacturer's documentation.

Using Thermocouple Sensors

Thermocouple sensors have low sensitivity and are very susceptible to electrical noise. Therefore, they are often difficult to apply. In order to obtain the best possible measurement accuracy, the recommendations given here should be carefully applied.

Direct Connection

The Model 32 supports direct connection to Thermocouple sensors by using a software based Cold Junction Compensation scheme as follows:

1. The sensor input connection on the rear panel of the instrument is thermally anchored to a temperature sensor that is used for Cold Junction Compensation.
2. The Cold Junction Temperature is continuously monitored and converted to a Cold Junction Voltage by performing a 'reverse lookup' of the sensor's calibration curve.
3. When a sensor reading is taken, the Cold Junction Voltage is subtracted from the measured voltage. The result is used to compute actual sensor temperature by using a 'forward lookup' on the sensor's calibration curve.

It is important that Thermocouple sensors be connected directly to the input connector as described in the section below. For example, if the thermocouple wires were first connected to Copper wires, then to the Model 32 input, the Cold Junction Compensation cannot function properly and measurement errors will result.

The Cold Junction Compensation function may be turned On or Off for each input channel. This is done by using the "CJcomp" field of the [Input Channel Setup Menu](#).

Adding New Thermocouple Types

New thermocouple types may be added to the Model 32 by adding a new user sensor type and corresponding calibration curve. This procedure is described in the section below titled [Adding a New Sensor](#).

Since the software Cold Junction Compensation technique used by the Model 32 depends on the thermocouple's calibration curve, it is important to note that the temperature range of the curve must include room temperature.

Cold Junction Compensation Errors

Cold Junction Compensation is required for any instrument to measure thermocouple sensors accurately. The most accurate method for performing this is by using an external 'Ice Bath' setup. However, this is often impractical.

Cold Junction Compensation in the Model 32 controller is performed by a circuit that measures the temperature of the input connector pins. This reading is then used to look up a compensating voltage from the thermocouple's calibration curve

The back-shell of the input connector should always be installed. This will minimize errors caused by local air currents.

Offset Calibration

Offset calibration is used to calibrate the Cold Junction Compensation circuit and is recommended when a thermocouple is first installed or any time a thermocouple is changed.

An appropriate curve must be selected and Cold Junction Compensation must be enabled before calibration can be started.

1. Connect the thermocouple.
2. Locate the controller away from drafts as these may affect compensation.
3. Allow the instrument to warm up for at least ½ hour without moving or handling the sensor.
4. Insert the thermocouple into the ice-bath, liquid nitrogen, liquid helium, or other known fixed temperature. The temperature should be close to the measurement temperature that requires best accuracy.
5. Read the displayed temperature in units of K or C, then subtract the known actual temperature from the reading to determine the CJ offset value.
6. Enter the CJ offset value into the controller by going to the SYS menu and scrolling down to the CJ offset field. This completes the procedure.

Check the calibration by verifying that the correct temperature is being read.

Calibration Errors

Variation in the manufacture of thermocouple wire and its annealing over time can cause errors in temperature measurement.

Instruments that measure temperatures above about 0°C will usually allow the user to correct calibration errors by adjusting an offset in order to zero the error at room temperature. Unfortunately, in cryogenic applications, thermocouples lose sensitivity at low temperatures so a single offset voltage correction is insufficient. For example, if calibration errors for a Type K thermocouple are zeroed at room temperature, a reading near Liquid Nitrogen temperatures may have an error of 5K.

Correction of Calibration Errors over a wide range of temperature can be made by using the Model 32's CalGen™ feature. Here, the controller should be stabilized at both temperature extremes. Then, CalGen™ will generate a new sensor calibration curve that best fits the two points to the actual sensor voltage readings.

Often, CalGen is done by taking a reading at room temperature, then a second reading with the sensor in Liquid Nitrogen. Since a thermocouple's sensitivity is relatively constant above room temperature, this procedure will give good accuracy over a wide range of temperature.

AC Power Line Noise Pickup

AC power noise pickup is indicated by temperature measurements that are significantly in error. In extreme cases, there may be no valid measurements at all.

Thermocouples have relatively high resistance leads, and each lead is made from a different material. Therefore, they are much more sensitive to AC pickup than sensors using copper wires.

A ground loop will cause significant AC coupling into the sensor. However, if the connection procedures described above are carefully followed, ground loops through the sensor leads will be avoided.

When a grounded sensor is used, a poor quality ground may have sufficient AC voltage to exceed the input range of the controller. This can often be corrected by running a copper connection from a point near the sensor ground and the chassis ground of the controller. Defective building wiring or insufficient grounding is usually the root cause of this type problem.

Most common AC noise pickup problems are caused by capacitive or magnetic coupling into the sensor wires. Again, the thermocouple's high resistance leads make this type coupling very efficient. General recommendations to minimize coupling include:

1. Minimize the length of thermocouple wires. For example, use a thermocouple Module near the sensor to convert the thermocouple wires to copper as soon as possible.
2. Twist the wires. Twisted wire for various types of thermocouples is available from several vendors.
3. Avoid running sensor wires near, or parallel to AC power lines.
4. Use the largest diameter sensor wires possible (Lowest AWG). This will reduce the lead resistance and, therefore, reduce coupling. However, in many cryogenic applications, wire size must be kept small because thermocouple wire is a good heat conductor.

Connecting Grounded Thermocouples

For best performance, thermocouple sensors should be floating. This will ensure that no noise currents can flow in the sensor leads and that no common-mode noise voltage will be directly coupled into the controller.

If a thermocouple must be grounded, the ground point should be a good earth ground that has the same potential as the earth ground of the instrument. If the ground point is floating or only loosely connected to earth ground, significant noise pickup can result.

Since floating thermocouples will always give the best accuracy, they should be electrically insulated by using small Sapphire washers.

Assuming that a grounded thermocouple is properly connected, the controller should operate properly. If this is not the case, the problem can usually be tracked to the ground connection made at the sensor relative to the ground at controller.

The ground potential at the thermocouple sensor must fall within the ± 5 volt input range of the controller.

Usually, the voltage difference between the sensor ground and the controller's ground is an AC power line signal. It can be seen with a battery powered AC voltmeter connected between the controller's chassis and a ground point near the sensor.

If there is a significant voltage difference, a safety hazard may be present. Building wiring should be tested before proceeding.

A voltage difference caused by a loose, or non-existent, ground reference can be corrected by:

1. Establishing a good quality ground point that the controller and sensor grounds are both connected to.
2. Running a ground strap. The preferred connection of the ground strap would be from a ground point near the sensor to the Third-Wire ground connection of the controller's AC power cord. If this is not available, the strap can be connected to the controller's chassis.

CalGen™ Calibration Curve Generator.

The CalGen™ feature is used to generate new calibration curves for Silicon Diode, thermocouple or Platinum sensors. This provides a method for obtaining higher accuracy temperature measurements without expensive sensor calibrations.

Most Cryo-con™ temperature controllers support CalGen™ directly on the instrument. However, the utility software package implements the same algorithm and can be used with virtually any instrument capable of measuring temperature.

Curves can be generated from any user selected sensor calibration curve and are written to a specified internal user curve location.

For Diode sensors, the user may specify one, two or three data points. CalGen will generate the new curve based on fitting the input curve to the user specified points.

Platinum or thermocouple calibration curves require one or two data points. The generated curve will be a best fit of the input curve to the two specified input points.

Since CalGen fits a sensor calibration curve to measured data, any errors in the Model 32's measurement electronics are also effectively cancelled.

 **Note:** CalGen™ is re-entrant. Therefore, the user can enter or exit the CalGen™ menus at any time without loss of previously captured data points. For example, a data point may be captured near 300K, next, the user may exit the CalGen™ process in order to stabilize the controller near 77K. When the CalGen™ menu is re-entered for curve generation, the point captured at 300K is still valid.

CalGen™ Initial Setup

Generation of a calibration curve using CalGen™ requires the measurement various temperature points. Therefore, an input channel must be configured with the correct sensor before the CalGen™ process can start.

To initiate the curve generation, select the CalGen field on the Input Channel Setup menu. This will take the screen to a sub-menu for the specific sensor type.

 **Note:** Before CalGen can be initiated, there must be a valid temperature reading on the selected input channel. If this is not the case, selecting the CalGen™ field will cause the display of an error message.

When the input channel has a valid reading, CalGen will determine if the sensor is a Diode, Platinum, or a thermocouple sensor. Further, the calibration curve of the selected input sensor will be used as the input to the curve generation process.

Using CalGen™ With Diode Sensors

Options for generating Diode calibration curves are:

1. One point near 300K. The portion of a Diode Sensor curve above 30K will be fit to a user-specified point near 300K. This is a two-point fit where the 30K point is taken from the existing calibration curve. The portion of the curve below 30K is unaffected.
2. Two points: 300K and 77K. Here, two user-specified points are taken to fit the diode curve region above 30K. The entire curve is offset to match the 77K point, then, the >30K region is fit to the two points.
3. Three points: 300K, 77K and 4.2K. Two points above 30K are fit as in the selection above. Then, a third point is used to fit a single point in the high-sensitivity region below 20K.
4. One point near 4.2K. This is a two-point fit where the 20K point is taken from the existing calibration curve. The portion of the curve above 20K is unaffected.

For a Diode Sensor, a sub-menu will be displayed that allows the user to select the number of points desired for the CalGen™ fit.

First CalGen™ Menu, Diode Sensor		
1	E1pt CalGen @300K <input type="checkbox"/>	Pressing the Enter key will select curve generation with a single point near 300K.
2	E2pt CalGen <input type="checkbox"/>	Pressing the Enter key will select curve generation at two points where both points must be > 50K.
3	E3pt CalGen <input type="checkbox"/>	Pressing the Enter key will select curve generation three points: Two above 50K and one near 4.2K.
4	E1pt CalGen @4.2K <input type="checkbox"/>	Pressing the Enter key will select curve generation with a single point near 4.2K.

Table 33: First CalGen™ Menu, Diode Sensor

From this screen, select the desired number of points. For example, select '2 point'. This will take the display to the two-point curve generator screen shown here.

CalGen™ Menu, 2-point Diode Sensor		
1	E 300.000 Capture #	The exact temperature at a point near 300K is entered here. Note: if CalGen™ has not been used on this channel before, the word Capture will appear. Otherwise, the last captured sensor reading will appear.
2	E Unit: 0.98257V ■	Pressing the Enter key will capture the existing unit reading and associate it with the 300K point. The value will be displayed on line 1 above.
3	E 77.000 Capture #	The exact temperature at a point near 77K is entered here.
4	E Unit: 1.28257V ■	Pressing the Enter key will capture the existing unit reading and associate it with the 77K point. The value will be displayed on line 3 above.
5	E New Curve ■	Pressing the Enter key will initiate the generation of a new curve.

Table 34: CalGen™ Menu, 2-point Diode Sensor

The two temperature points, one near 300K and the other near 77K may be entered in any order.

To enter the 300K-point, change the field 300.000 to the exact required temperature. Then, allow the temperature measurement to stabilize. When the measurement is stable, select the Capture field next to the temperature field. This will cause the Model 32 to capture the sensor reading and associate it with the specified temperature.

When a sensor reading has been captured, the actual reading will be displayed in place of the word Capture. Note that the user may capture a new reading by selecting this field again, even if it already contains a reading.

The Unit field of this screen will display the actual sensor reading in real time. This will allow the user to determine when the unit is stable at the required temperature.

Next, the second temperature must be entered in the same way as before.

When both temperature points have been entered, the user may select the New Curve field in order to generate the new curve. This will cause the display of a menu like the one shown here:

CalGen™ New Curve Menu		
1	15:User Sensor 1 #	Sets the curve number for the generated curve. Numeric entry. Note: only the user curves can be written.
2	--Save--	Pressing the Enter key will cause the generation of a new curve. The curve will be stored at the curve number specified on line 1.

Table 35: CalGen™ New Curve Menu

From this screen, the user must select the target user curve for the generated curve.

Finally, select the Save field in order to generate the curve and store it in the selected user location.

Note: The CalGen process may be aborted by pressing the **Esc** or **Home** key.

Using CalGen™ With Platinum and Thermocouple Sensors

The calibration curve generation procedure for Platinum or Thermocouple sensors is the same as for the diode sensors described above. However, Platinum sensor curves are generated using two user specified points. Therefore, the selection of the number of points is not required.

System Shielding and Grounding Issues

Grounding Scheme

The grounding scheme used in all of Cryo-con's instruments is based on a Single-Point-Ground and is designed to minimize ground-loop and noise pickup by assuming that the Sensor and Heater elements are electrically floating, but the remote interfaces are not.

The Single-Point-Ground

The internal Single-Point-Ground is the voltage reference point for the instrument's grounding scheme. All circuits are designed so that no current will normally flow through the connections to this ground. Therefore, it provides a good quality, low impedance path to ground for any undesired currents that are coupled into the equipment.

AC Power Entry

AC Power enters the instrument directly into a power entry module. This provides fusing, line voltage selection and RFI filtering.

The Building Ground, often referred to as "Earth-Ground", "Shield-Ground" or "Third-Wire-Ground" is connected to the shield of the Power Entry RFI filter, then to the instrument's Single-Point-Ground. Since the grounding and shielding scheme depends on having a good quality ground, this Earth-Ground connection is extremely important. Noise and ground loop problems are often traced to how this connection is made.

If your facility does not provide a building ground, it is strongly recommended that one be fabricated.

Sensor Connection

For best performance, all sensors connected to the instrument should be electrically isolated (floating) from any other grounds.

Sensors used in cryogenic thermometry are often high impedance. For example, a Silicon Diode temperature sensor will have about 160K ohms of impedance at 5K. Because of this, a very efficient antenna can develop around the sensor and its connections. Requiring these sensors to be floating and providing a low impedance path to ground is the most effective way to eliminate noise pickup from this antenna effect.

To ensure that the instrument's grounding scheme is working effectively:

1. Make sure that the sensors are floating.
2. Make sure that the input cable shields are connected to the connector's metal backshell using the shield clip provided with the connector.
3. Make sure that the Third-Wire-Ground is good quality and not conducting current.

Control Loops

The circuitry in the Control Loop Area provides power to external heater elements. The grounding of this area is identical to the Sensor Area described above. Note however that heater elements usually have very low impedance. Therefore, noise pickup issues are not near the problem that they are in the Sensor Area.

Digital Circuits

The digital circuits of the Model 32 cannot assume that its external connections are floating. Therefore, it is connected to the Single-Point-Ground through a Resistor-Capacitor network in order to prevent ground loops.

RS-232 and GPIB connections bring a ground return connection from the host computer. This means that the Digital area must be at the same voltage as the host's circuit board ground; Otherwise, ground loop currents will flow from the host, through the instrument and back into the Earth-Ground.

An R-C network is used to eliminate common-mode voltages from the unit's power supply, but also has a high enough impedance to reduce ground-loop current flow.

Further, since it is isolated from the other areas of the circuit, no current carrying paths can flow through the more sensitive analog circuits.

The RS-232 Connection

The RS-232 connection is a three-wire serial communication scheme. Two wires carry signals and the third carries a ground reference.

When either of these interfaces is connected to a Cryo-con controller, the voltage of the digital area is established by the ground reference of the connected interface.

Because of the internal R-C network connection to ground, little if any current can flow back through the system grounds.

The GPIB Connection

The GPIB is a 24-wire communications protocol that has six control signal grounds, one data signal ground and one shield ground.

In the Cryo-con controller, the control and signal grounds are connected together and used to establish the ground reference potential for the digital area.

The Shield ground connection is connected to the instrument's Single-Point-Ground through a jumper. The jumper is available since some manufacturers connect the GPIB shield ground to their circuit board ground and, therefore, ground loops are established through the shields. Removing the jumper will break this ground.

Cryo-con Utility Software

Cryo-con provides a PC compatible utility software package with all instruments. This is available on CD, or on the Internet.

Utility software can be used to control and configure any Cryo-con instrument via the RS-232, LAN, USB or IEEE-488 interface. It runs under all versions of the Windows operating system. This software provides several useful functions, including:

1. Real-time strip charts of temperature.
2. Data Logging. This function allows the user to record data from the instrument at a specified sample rate. The resulting file is compatible with most spreadsheet and data analysis software.
3. Download or upload sensor calibration curves. The software will accept curves in Cryo-con .CRV, Lakeshore .340 or Scientific Instrument's .txt format. In fact, it will read almost any table of temperature vs. sensor units.
4. Cryo-con's CalGen™ function is implemented. This function allows the user to fit an existing sensor calibration curve to one- two- or three user-specified points. The result is a high accuracy sensor calibration at low cost.
5. Upload and download PID tables to a Cryo-con temperature controller. These tables can be generated by using a simple text editor and downloaded to the controller.
6. Configuration of any of the instrument's remote interfaces.
7. Flexible 'Help' interface that documents all instrument remote commands with a cut-and-paste type interface.
8. 'Interactive Mode' provides interactive communication with the instrument over any of the remote interfaces.
9. Instrument calibration using a simple step-by-step menu driven process.
10. Uploading and downloading instrument firmware. Updates may be obtained on CD, or on the Internet.

Installing the Utility Software

From a CD, the utility software package does not require installation. It can be executed from the CD directly by running the UTILITY.EXE program.

When the software is downloaded off of the Internet, it is in a self-extracting ZIP format and must first be un-zipped onto hard disk.

Connecting to an Instrument

The desired remote interface connection may be selected by clicking **Comm>Port Select** from the main menu.

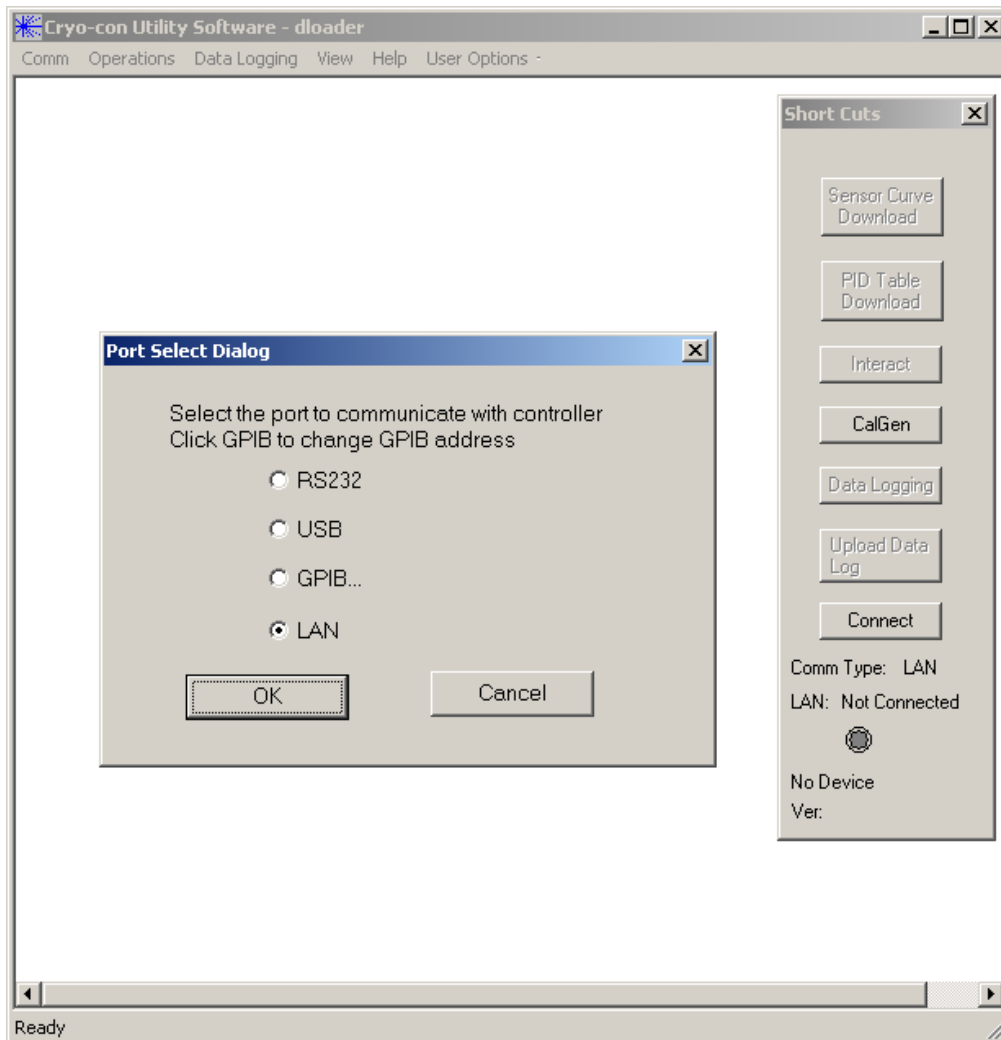

Select the desired communications port and then click **OK**.

Click on the **Connect** button of the shortcut menu bar or on **Comm->Connect** from the main menu to connect to the instrument.

After a short delay, the connect LED should light and the instrument type will be displayed. Also, most of the grayed-out fields on the menu bars should activate.

Using the Interactive Terminal

The Utility Software's Interactive Terminal mode allows the user to send commands to the instrument and view the response.

Terminal mode is selected by selecting **Comm>Interact** from the main menu or **Interact** from the shortcut bar. This will result in the display shown below.

To interact with the instrument, type a remote command into the dialog box and click **Send**. The command will be transmitted to the instrument and a response, if any, will be displayed on the background window.

To exit terminal mode, click the **Quit** button on the dialog box.

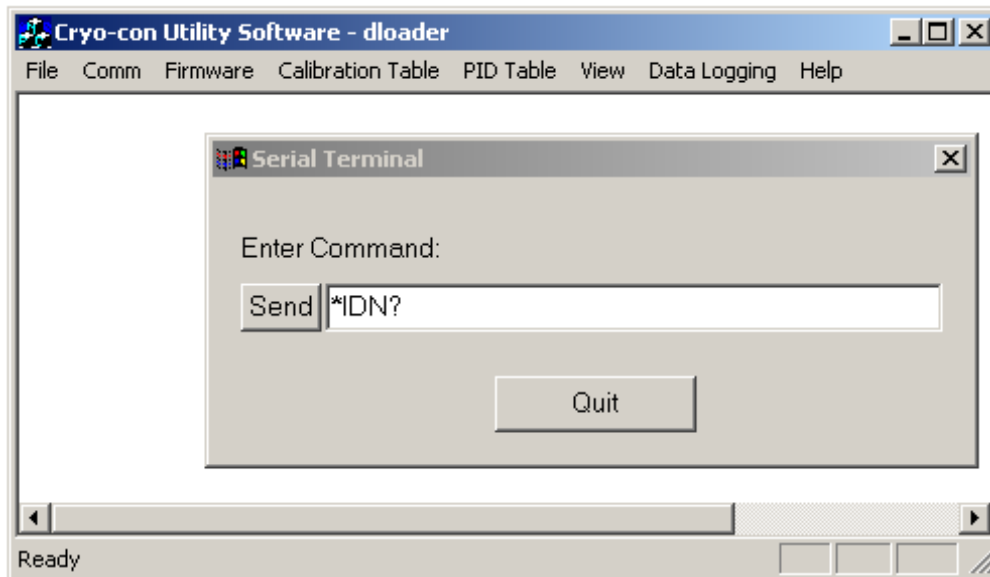

Downloading or Uploading a Sensor Calibration Curve

Sensor calibration curves may be transferred between the PC and the instrument by using the Calibration Table menu.

To download a curve (send it from the PC to the instrument), either select "Sensor Curve Download" from the shortcut bar or **Operations>Sensor Curve>Download**

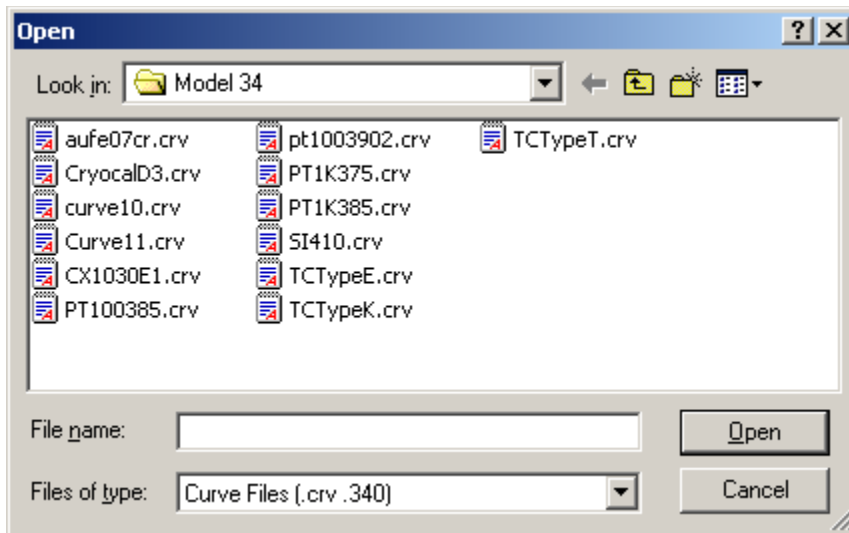

from the main menu. This will cause a file selection dialog box to appear as follows:

From this screen, the desired calibration curve is selected. Cryo-con calibration curves have the file extension of .CRV. Lakeshore curves with the extension .340 may also be selected. Scientific Instruments .txt files may be downloaded by first selecting a file type of *.* and then selecting the desired calibration curve file.

Cryo-con .CRV files are ASCII text files that may be edited by any text editor.

After selecting the file and clicking on **Open**, the selected file will be read and the Edit Curve Header dialog box will appear. This box contains information extracted from the curve file header that can be modified, if desired, before the curve is downloaded.

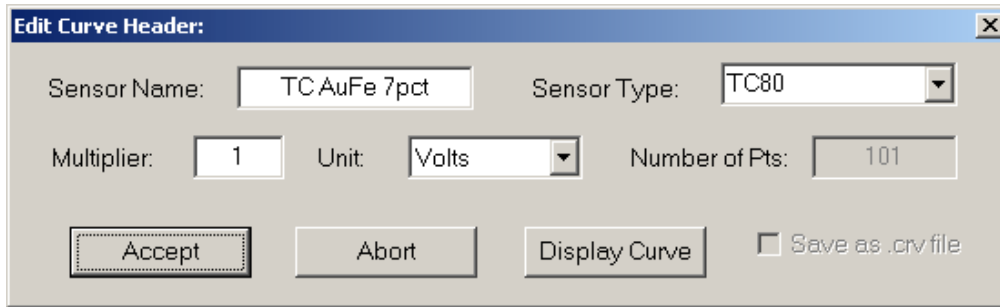

“Sensor Name” is any 15-character string and is only used to identify the sensor.

Sensor type can be selected from a pull-down menu or entered directly. Note that different models of Cryo-con instruments support different types of sensors. Therefore, it is important to enter a sensor type that is supported by the specific product. If the instrument receives a sensor type that it does not support, the ‘Diode’ type is selected. The section titled “[Supported Sensor Configurations](#)” gives complete information on sensor types.

The Multiplier field is used to select the sign of the sensor’s temperature coefficient. A value of -1 selects a Negative-Temperature-Coefficient sensor while a value of 1 selects a Positive-Temperature-Coefficient.

The Unit field selects the units used in the calibration curve. Choices are: Volts, Ohms or LogOhm.

Checking the ‘Save as .crv’ will save the curve to disk as a Cryo-con .crv file.

The sensor curve may be viewed as a graph by clicking the 'Display Curve' button. An example plot is shown here:

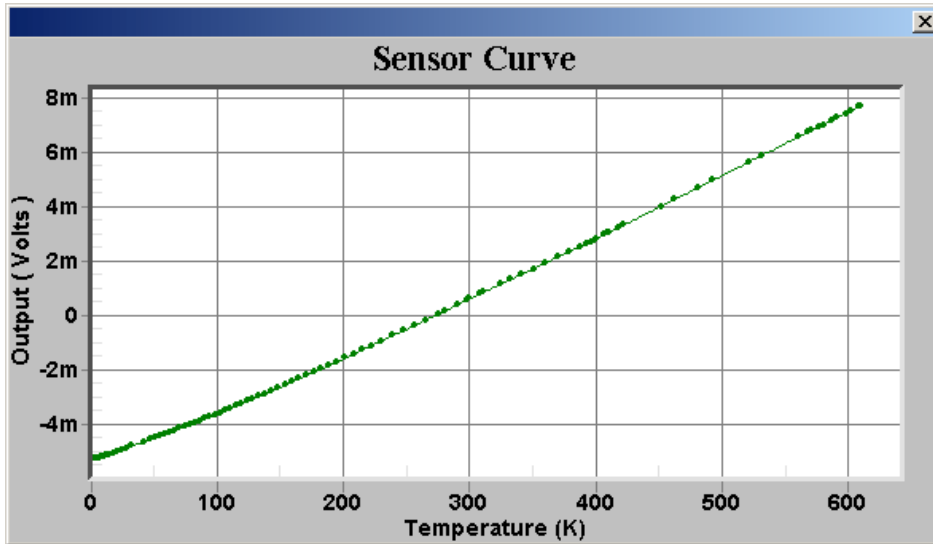

After completing any desired changes in the "Edit Curve Header" dialog box, click 'Accept' to proceed. Then the, curve number dialog box will appear:

A user calibration curve should be entered here. For the Model 32, user curves are 1 through 4. For the Model 34 and Model 62, user curves are 1 through 12.

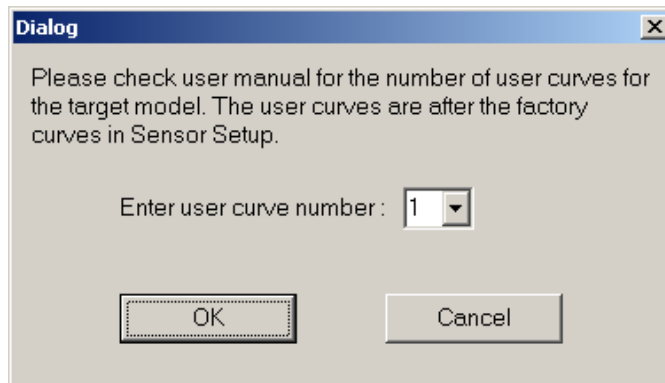

When 'OK' is selected, the sensor calibration curve will be downloaded to the instrument. During the transfer, curve data points will be displayed in the window's main pane. Upon completion, the Download Complete dialog box will appear:

Dismiss this dialog box to complete the download process.

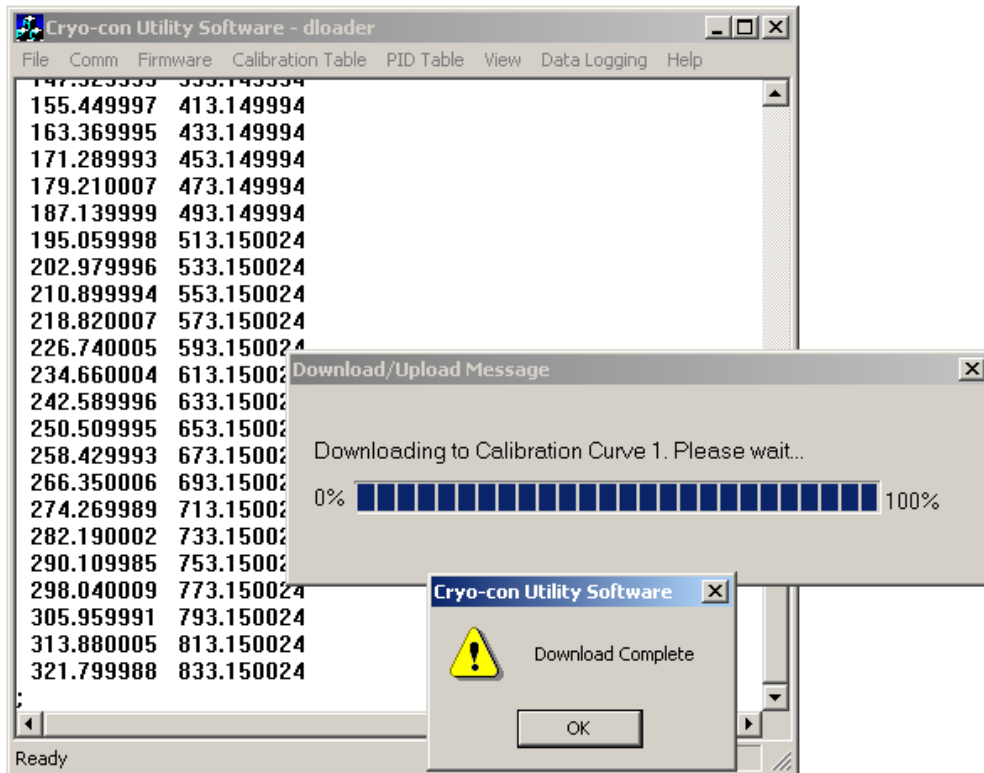

To upload a calibration curve, use the same procedure and select **Upload**. This will transfer a curve from the instrument to the PC.

Downloading or Uploading a PID Table

A PID table may be transferred to the instrument by selecting **PID Table>Download** from the main menu toolbar.

PID tables are transferred from the instrument to the PC by using **PID Table>Upload**.

From this point, the sequence is identical to the calibration curve transfer process described above.

Using the Real-Time Strip Charts

The real-time strip chart feature of the Utility Software lets the user continuously display any combination of input channels on the computer display.

This function is initiated by selecting the **View** command on the Utility Software's main toolbar, then selecting the desired channels to monitor.

A strip chart will be displayed for each channel selected. The dialog box will show the channel's Input Identifier, Name String and a chart of current temperature.

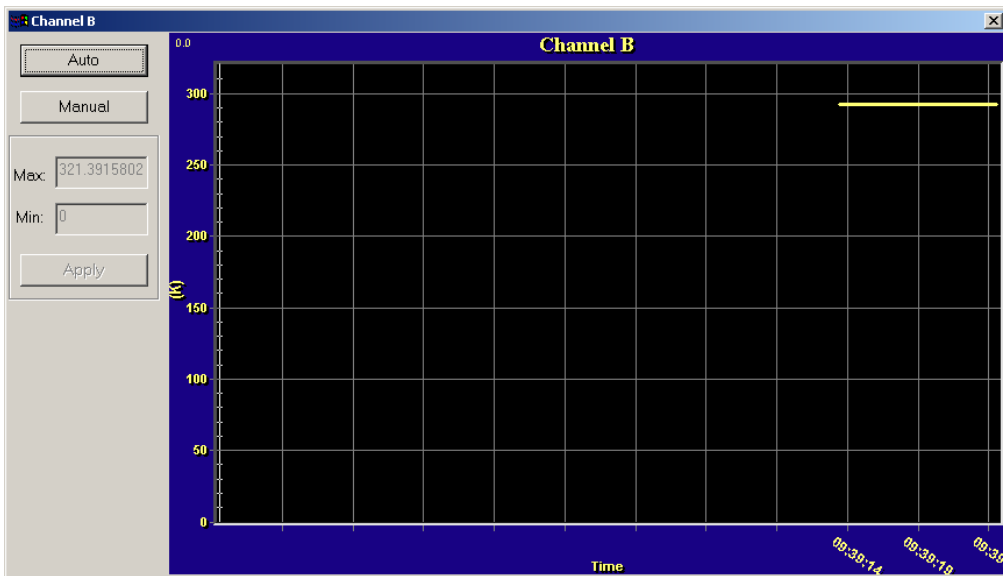

The update rate of the chart is locked to the program's Data Logging Interval. The section below details how to set this value.

Data Logging

The Utility Software will perform data logging on all of the instruments input and control output channels. The result is a disk file in Comma-Separated-Value, or CSV format. This format is compatible with any data analysis or charting software including Microsoft Excel.

To initiate data logging, select the **Data Logging** button from the Utility Software's main menu. The Data Logging Setup dialog box will now appear.

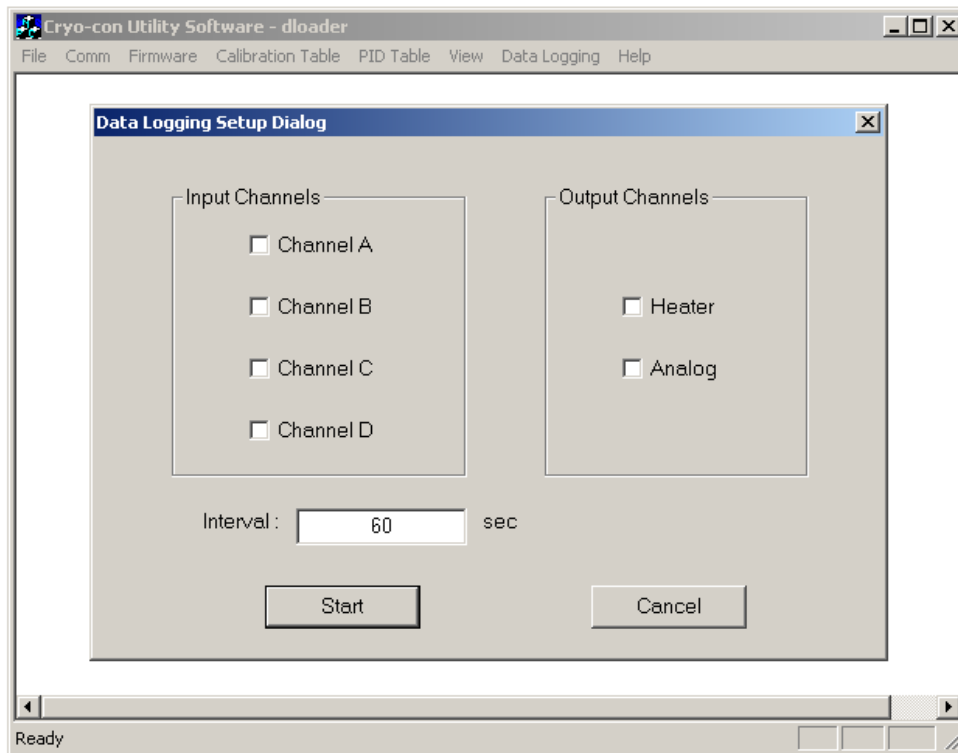

On this dialog box, check the desired channels and set an Interval value in Seconds. The minimum interval is 0.1 Second.

When the **Start** button is clicked, a file selection dialog box will be shown.

From this dialog box, enter a file name and select the directory where data logging

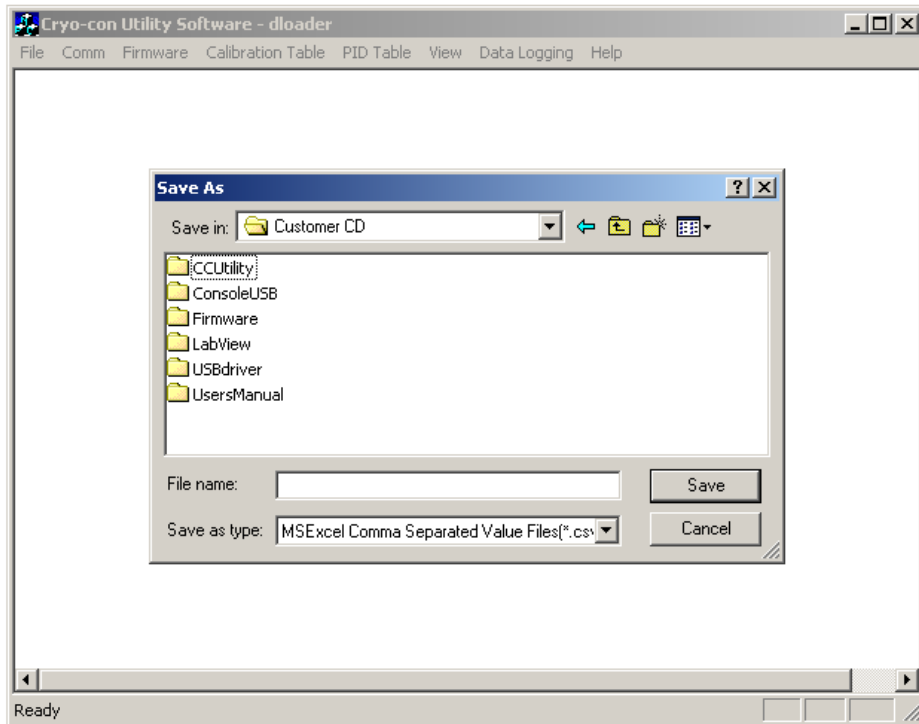

results will be saved.

As soon as the **Save** button is clicked, the software will begin continuous data logging to the specified file.

While data logging is in progress, a dialog box will be displayed that allows the user to stop logging. When this **Stop** button is clicked, logging is stopped and the log file is closed.

Remote I/O command HELP

Help for the remote interfaces and remote commands is available by clicking on the **HELP>Contents** button from the Utility Software's main menu.

A standard HELP screen will be shown that is indexed and searchable.

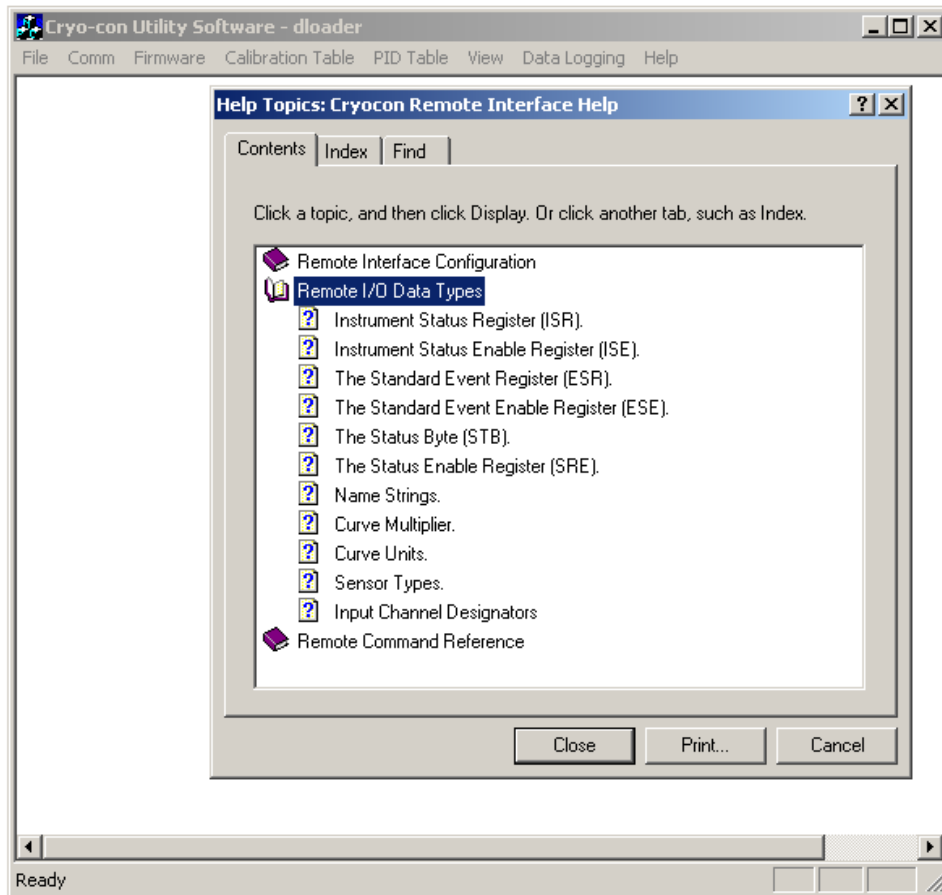

CalGen Calibration Curve Generator.

The CalGen™ feature is used to generate new calibration curves for Silicon Diode or resistor sensors. This provides a method for obtaining higher accuracy temperature measurements without expensive sensor calibrations.

Most Cryo-con™ temperature controllers support CalGen™ directly on the instrument. However, the utility software package implements the same algorithm and can be used with virtually any instrument capable of measuring temperature.

New Curves can be generated from any user selected sensor calibration curve and are written to a specified file.

For Diode sensors, the user may specify one, two or three data points. CalGen will generate the new curve based on fitting the input curve to the user specified points.

Platinum or other resistor calibration curves require one or two data points. The generated curve will be a best fit of the input curve to the two specified input points.

Since CalGen fits a sensor calibration curve to measured data, any errors in the instrument's measurement electronics are also effectively cancelled.

CalGen™ Initial Setup

To start the CalGen™ process, either select **CalGen™** from the shortcut bar, or select Operations>CalGen from the main menu. This will initiate the process of generating a new sensor curve.

Using CalGen With Diode Sensors

Options for generating Diode calibration curves are:

5. One point near 300K. The portion of a Diode Sensor curve above 30K will be fit to a user-specified point near 300K. This is a two-point fit where the 30K point is taken from the existing calibration curve. The portion of the curve below 30K is unaffected.
6. Two points: 300K and 77K. Here, two user-specified points are taken to fit the diode curve region above 30K. The entire curve is offset to match the 77K point, then, the >30K region is fit to the two points.
7. Three points: 300K, 77K and 4.2K. Two points above 30K are fit as in the selection above. Then, a third point is used to fit a single point in the high-sensitivity region below 20K.
8. One point near 4.2K. This is a two-point fit where the 20K point is taken from the existing calibration curve. The portion of the curve above 20K is unaffected.

Using CalGen™ With Resistor Sensors

The calibration curve generation procedure for Platinum or other resistor sensors is the same as for the diode. However, these sensor curves are generated using two user specified points. Therefore, the selection of the number of points is not required.

Example CalGen™ Procedure

A complete procedure for calibrating a diode sensor at three points is shown here. Before the procedure can be started, the instrument must be connected and have a valid sensor connected.

The CalGen™ procedure will require the user to stabilize the input temperature at three user-selected points. It will capture data at each of these points and then generate a new curve from that data.

When a 3-point CalGen is started for a Silicon Diode sensor, the reference curve must first be selected. This is the curve that will be rotated and shifted to fit the selected points.

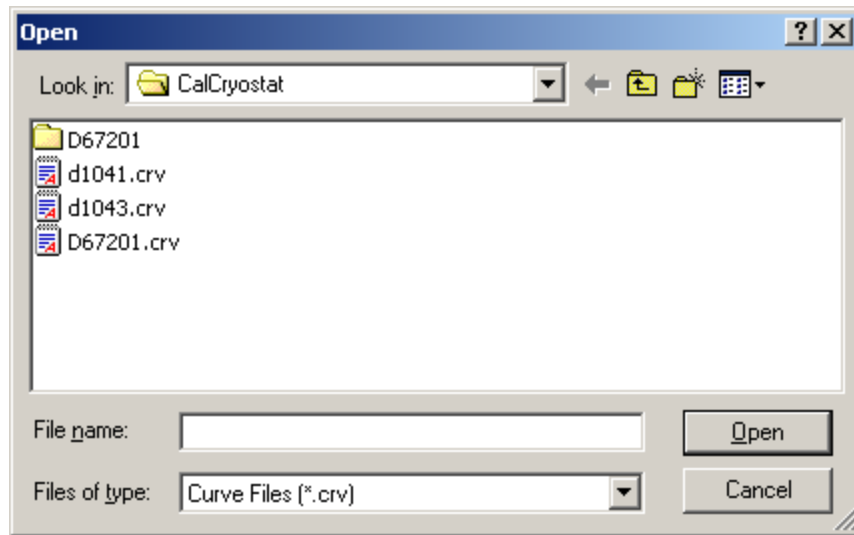

When the curve has been selected, the following dialog box will appear:

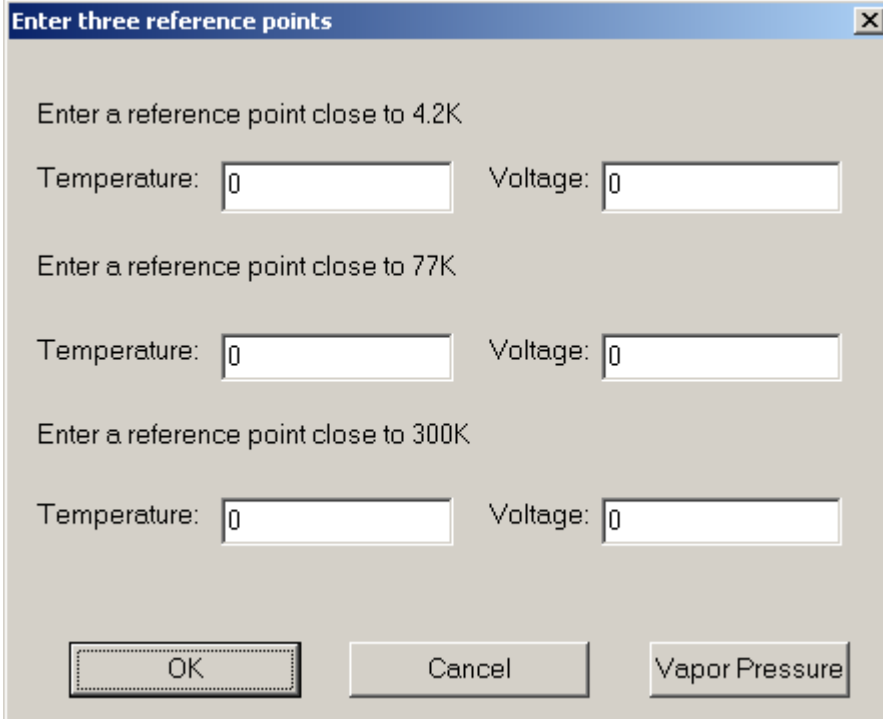

Enter three reference points

Enter a reference point close to 4.2K

Temperature: Voltage:

Enter a reference point close to 77K

Temperature: Voltage:

Enter a reference point close to 300K

Temperature: Voltage:

OK Cancel Vapor Pressure

The process requires you to completely fill out this dialog box by selecting a temperature and then copying the voltage (or resistance) reading corresponding to that temperature from the instrument.

Note that the Vapor Pressure button will take the user to a convenient calculator that will compute the temperature of various cryogenes from the current barometric pressure.

Once the dialog box has been completed, click OK to proceed.

To finish the process, you will be prompted to save the modified calibration curve to a file. Once complete, the file can be transferred to any Cryo-con™ instrument.

The Vapor Pressure Calculator.

The Vapor Pressure Calculator is a convenient aid that computes the actual temperature of most cryogens given the current barometric pressure. It can be launched directly off of the utility disk by executing "Vapor Pressure Calculator.exe" or from the CalGen™ dialog as shown above.

A typical calculation is shown here:

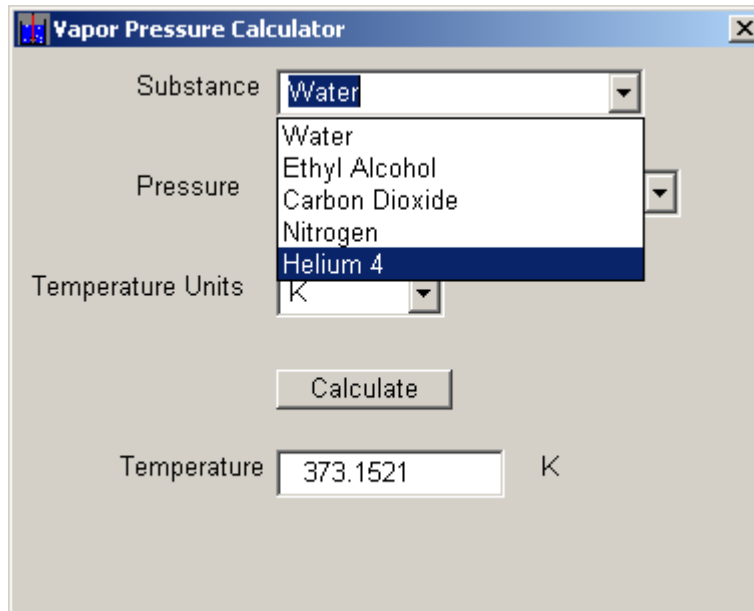

You must select the Substance from a drop-down list and then select the barometric pressure and temperature units.

Substance selections are shown here:

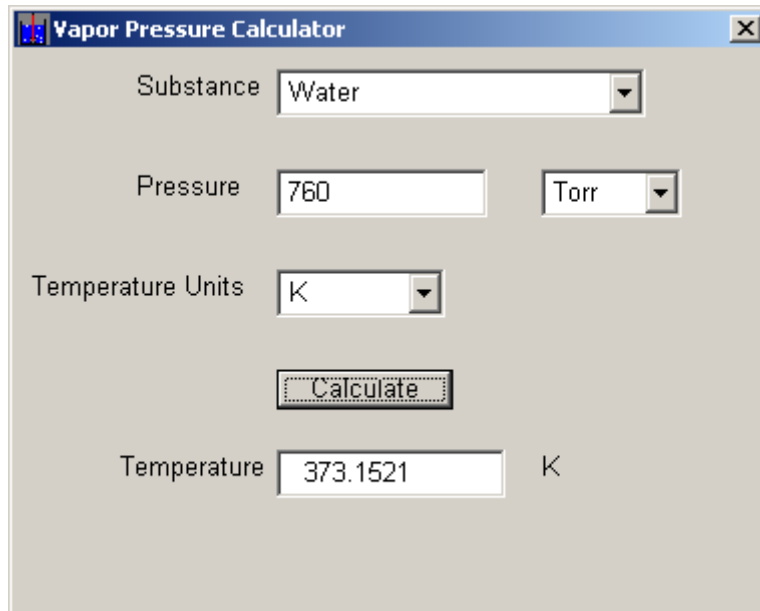

The screenshot shows a window titled "Vapor Pressure Calculator". It contains the following fields and controls:

- Substance:** A dropdown menu with "Water" selected.
- Pressure:** A text input field containing "760" and a dropdown menu with "Torr" selected.
- Temperature Units:** A dropdown menu with "K" selected.
- Calculate:** A button with a dotted border.
- Temperature:** A text input field containing "373.1521" and a unit label "K" to its right.

Downloading Instrument Firmware

A primary feature common to all of Cryo-con's instruments is the ability to download new firmware. Firmware must be matched to the product's model number and hardware revision level. For that reason, please contact Cryo-con via e-mail or telephone for the most recent firmware.

Firmware updates include the addition of new features as well as bug fixes. Installing a new revision writes to all of the available FLASH type memory in the instrument. Therefore, existing calibration curves, instrument setups and PID tables are reset to factory defaults. If user information, such as sensor calibration curves, has been installed, it is recommended that these be uploaded to the computer before new firmware is installed. This way, they can be re-installed after the new firmware.

Firmware download does NOT erase the instrument's calibration data.

Note that FLASH memory is inherently non-volatile and may be re-written in excess of 100,000 times. Therefore, the user need not be concerned about excessive re-writing.

 **Note:** Firmware can only be downloaded using the RS-232 serial interface. It cannot be downloaded via the GPIB. Therefore, make sure that you have a null-modem RS-232 cable attached to the controller and that the Utility Software is configured to use RS-232 at a baud rate of 9600. Do NOT use baud rates above 9600 since the firmware update speed is limited by the programming speed of the flash memories.



Caution: To protect the instrument from casual downloads and possible corruption, the Utility software must be executed with a command line argument of `-f` for a firmware download and `-d` for a firmware upload. The utility disk contains a shortcut named UtilityFD that contains these command line arguments.

To download new firmware, select **Firmware>Download** from the Utility Software's main menu. If the Download item is grayed-out, you must exit the utility software and re-start it with the correct command line switches as noted in the caution above. Selecting a firmware download will result in the display of a file selection dialog box as shown below:

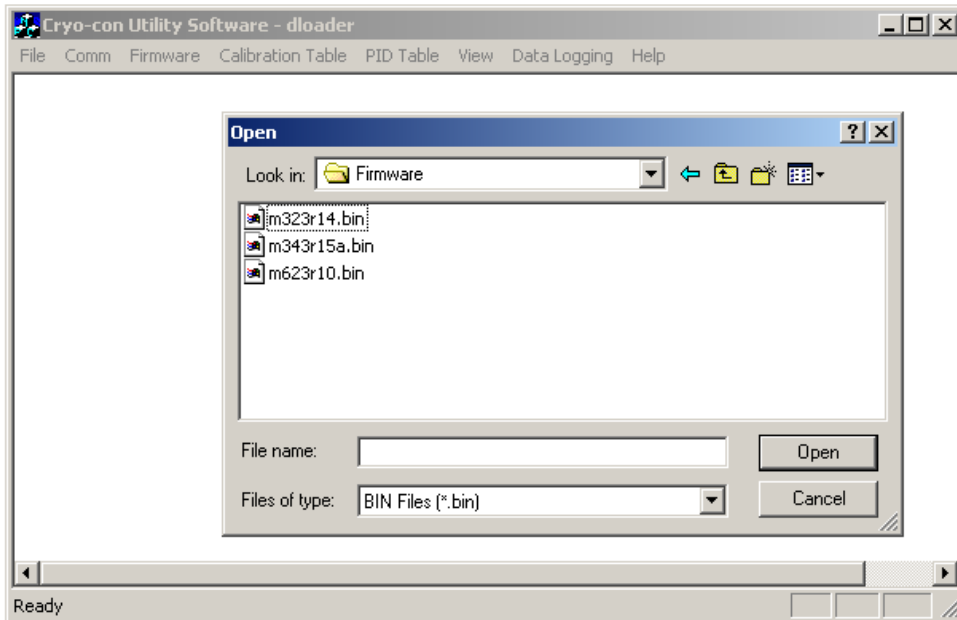

In this dialog box, firmware file names are coded as shown below:

MmmRev.BIN

Where mm is the Model Number, eg: 32, 34, 62 etc. and Rev is the revision code in the format XrXX where the lower case r indicates a period character. The file extension is always BIN.

From the file dialog box, find and select the desired firmware file. Then click on the Open button in order to initiate the firmware download.

Firmware download will be initiated immediately after the Open button is clicked. Once download has started, you should not attempt to stop it.

When a firmware download has successfully started, the VFD display will continuously display the number of records transmitted as shown here.

There are 1008 records in a complete firmware download. The process should take about 15 minutes.

Record 001 of 502
Errors: 000

The PC screen will show a bar-graph of progress during download.

When the download is complete, the controller will freeze and the PC will display a 'Download Complete' dialog box.



Caution: When a firmware download is complete, the controller should automatically reset within 10 seconds. Do not unplug it. When the reset process is complete, hold down the **Enter** key and power-cycle the instrument from the front panel. The new firmware should boot up.

If a non-recoverable communications error occurs during firmware download, the controller will power up in an error mode where it is looking for a new firmware transfer on the serial port. The VFD screen will display the transfer display shown above. In this case, repeat the above procedure until the entire firmware transfer sequence works correctly.

NOTE: Factory defaults may be restored at any time by use of the following sequence: 1) Turn power to the Model 32 OFF. 2) Press and hold the **Enter** key while turning power back ON.

NOTE: The firmware download mode of the Model 32 may be forced by the following sequence 1) Turn power to the Model 32 OFF. 2) Press and hold the **Stop** key while turning power back ON. This sequence is intended for use when the controller is not operational and will not accept remote commands to place it in the download mode.

Instrument Calibration

Calibration of the Model 32 controller requires the use of various voltage and resistance standards in order to generate calibration factors for the many measurement ranges available.

Calibration is 'Closed-Case'. There are no internal mechanical adjustments required. The Model 32 cannot be calibrated from the front panel.

Calibration data is stored in the instrument's non-volatile memory and is accessed only via the remote interfaces. Calibration of a measurement range is the simple process of generating an offset and gain value. However, since there are several input ranges available on each sensor input, the process can be time consuming.



Caution: Any calibration procedure will require the adjustment of internal data that can significantly affect the accuracy of the instrument. Failure to completely follow the instructions in this chapter may result in degraded instrument performance.

The Cryo-con utility software used in this procedure will first read all calibration data out of the instrument before any modifications. It is good practice to record these values for future reference and backup.

Cryo-con Calibration Services

When the controller is due for calibration, contact Cryo-con for low-cost recalibration. The Model 32 is supported on our automated calibration systems which allow Cryo-con to provide this service at competitive prices.

Calibration Interval

The Model 32 should be calibrated on a regular interval determined by the measurement accuracy requirements of your application.

A 90-day interval is recommended for the most demanding applications, while a 1-year or 2-year interval may be adequate for less demanding applications. Cryo-con does not recommend extending calibration intervals beyond 2 years.

Whatever calibration interval you select, Cryo-con recommends that complete re-adjustment should always be performed at the calibration interval. This will increase your confidence that the instrument will remain within specification for the next calibration interval. This criterion for re-adjustment provides the best measure of the instrument's long-term stability. Performance data measured using this method can easily be used to extend future calibration intervals.

Minimum Required Equipment

All calibrations require a computer with an RS-232 or IEEE-488 connection to the instrument. Additionally, reference standards are required for each input range as follows:

- The Silicon Diode input range (Calibration Type I10UA and V10UA) requires voltage references of 0.5 and 1.5 Volts DC and a resistance standard of 100K Ω .
- The Constant-Voltage AC resistance ranges (Type AC10UA, AC100UA and AC100UA) require the use of 100K Ω , 10K Ω , 1K Ω , 100 Ω and 10 Ω resistances.
- The 100 Ω Platinum range (Type R1MA) requires a 100 Ω and a 10 Ω resistor.
- The 1000 Ω range (Type R100UA) requires 1K Ω and 100 Ω resistors.
- The 10,000 Ω range (Type R10UA) requires 10K Ω and 1K Ω resistors.
- The 80mV thermocouple (optional) range requires voltages of +0.075 and – 0.075 Volts.

The test equipment recommended for complete calibration is a Fluke 5700A DMM calibrator.

The Basic Calibration Sequence

You must first connect the Model 32 to a computer via the RS-232 (Serial) or IEEE-488 (GPIB) interface and then run the Utility Software provided with the controller. The Utility Software must be version 7.4.2 or higher.

From the start-up menu of the Utility Software, click the Connect button in the bottom of the Short Cuts toolbar. The software will connect to the instrument and display the connection status below the button.

In case of an error, please correct the port connection settings and try again.

From the main menu, select Operations->Unit Cal. The program will read the current calibration values from the instrument and display a calibration screen as shown below. All calibration operations can be performed by using this screen.

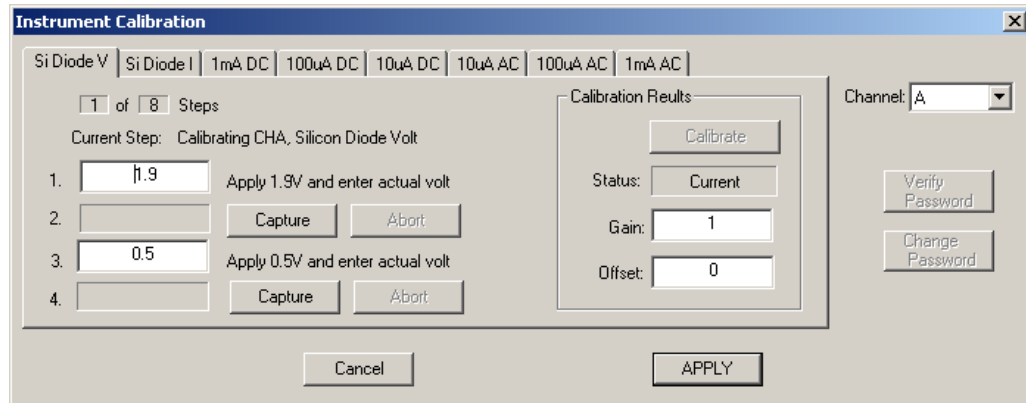

Figure 8: Instrument Calibration Screen

Note: Newer Cryo-con instruments will require a password before calibration data can be saved. The utility software will allow you to enter and change the password.

The default password is: **cryocon**

On the far right of the screen, a drop-down box selects the channel to be calibrated. Be sure you have selected the correct channel. In order to perform a complete calibration, you will need to calibrate each channel individually.

Along the top of the screen, there are tabs that show the types of calibration that are supported by the instrument. To perform a complete calibration of a single input channel, all calibration types must be calibrated.

Note the **Calibration Results** box on the screen. The **Status** field will initially be set to 'Current' and the **Gain** and **Offset** values shown will be those read from the instrument.

Note: If your calibration procedure requires saving historical values, you will want to record the Gain and Offset values shown on the initial screen before proceeding with actual calibration.

There are two methods available for calibration:

1. Automatic. The software will recommend voltages and resistances. You can set these values on the input channel and capture the instrument's actual readings. Then, the software will automatically generate offset and gain values for you.
2. Manual: You can manually enter Offset and Gain values and send them to the instrument.

Manual Calibration

To manually calibrate a range, select the desired range from the range type tabs and enter the desired Gain and Offset values in the boxes given and then, click the **APPLY** button.

Gain is a unit-less gain factor that is scaled to a nominal value of 1.0. It is usually computed by:

$$\text{gain} = (\text{UT} - \text{LT}) / (\text{UM} - \text{LM})$$

where:

UT is the upper target and LT is the lower target.

UM is the upper measurement and LM is the lower measurement.

Gain values greater than 1.2 or less than 0.8 are rejected as out of range.

Offset is in units of Volts or Ohms depending on the calibration type. Nominal value is 0.0. Positive or negative numbers are accepted. It is usually calculated by:

$$\text{Offset} = \text{UT} - \text{gain} * \text{UM}$$

Automatic Calibration

Automatic calibration uses the left-hand side of the calibration screen and is a four-step process:

1. Line 1 requires setting a upper target value on the input channel. Depending on the calibration range selected, this will be in Volts or Ohms.

First, establish a voltage or resistance on the selected input channel that is near the recommended value. Then, enter the actual value in the box provided.

2. Click the Capture button on Line 2. The software will wait for the reading to stabilize and then will capture the reading and display it in the edit box on Line 2.

While waiting for a stable reading, the following dialog box will be displayed:

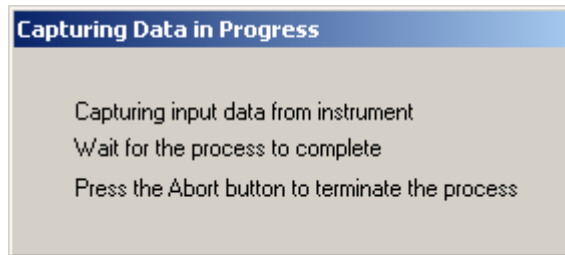

When the capture is complete, dismiss the following dialog:



3. Line 3 requires setting a lower target value on the input channel. Depending on the calibration range selected, this will be in Volts or Ohms.

First, establish a voltage or resistance on the selected input channel that is near the recommended value. Then, enter the actual value in the box provided.

4. Click the Capture button on Line 4. The software will wait for the reading to stabilize and then will capture the reading and display it in the edit box on Line 4.

When the above procedure is complete, you will have established upper and lower target values as well as upper and lower measurements. The edit boxes on lines 2 and 4 will contain the measured values. At this time, you may still change the target values on line 1 and 3 if desired.

Now, you can automatically compute the required gain and offset values by clicking on the **Calibrate** button in the **Calibration Results box**. This will change the **Status** field from 'Current' to 'Calibrated' and will update the **Offset** and **Gain** values with those calculated.

At this point, the values have been transmitted to the instrument!

In order to send the offset and gain values to the instrument's calibration memory, click the **APPLY** button. You will be required to confirm that you really want to update calibration memory.

Summary of Calibration Types

Calibration data must be generated for each input channel by sequencing through the various calibration types on each channel. A summary of types is given here:

Calibration Type	Voltage Range	Output Current	Description
SI DiodeV	0 – 2.5V	N/A	Voltage measurement for use with Silicon Diode temperature sensors.
SI Diode I	N/A	10 μ A	10 μ A constant-current source used with Silicon Diode sensors.
1mA AC	10mV, 1.25Hz	Autoranged	1mA range used with constant-voltage mode sensors.
100 μ A AC	10mV, 1.25Hz	Autoranged	100 μ A range used with constant-voltage mode sensors.
10 μ A AC	10mV, 1.25Hz	Autoranged	10 μ A range used with constant-voltage mode sensors.
1mA DC	0-2.5VDC	1.0mA	DC measurement of 100 Platinum RTD sensors.
100 μ A DC	0-2.5VDC	100 μ A	DC measurement of 1K Ohm Platinum RTDs
10 μ A DC	0-2.5VDC	10 μ A	DC measurement of 10K Ohm Platinum RTDs or other resistor sensors that use DC current excitation
VTC80	+80mV to -80mV	N/A	Thermocouple measurements. Valid only when optional thermocouple input is installed.

Calibration of Silicon Diodes

Silicon Diode sensors require the application of a precision 10 μ A current followed by reading the voltage-drop across the device. Therefore, calibration of a diode requires two steps: 1) Calibration of the input voltage reading and 2) Calibration of the 10 μ A current source.

Note that the voltage calibration must always be done first since the current source calibration requires a precision voltage reading.

Diode Voltage Calibration

To calibrate the diode voltage range, click on the **SI Diode V** tab and follow the sequence described above to send Gain and Offset values to the instrument.

The upper target requires connection of a 1.9 Volt source. The actual value is between 1.0 Volts and 2.4 Volts. If you do not have a precision voltage source, you can use a 1.5 Volt battery by using a high precision volt meter to measure it's actual voltage.

The lower target requires connection of a 0.5 Volt source. The actual value is between zero Volts and 0.6 Volts. If you do not have a precision voltage source, you can short the input channel for zero volts.

Constant-current Source Calibration

Calibration of the constant-current source is performed by using the **SI Diode I** tab. On this screen, only an upper target value is required since the current-source only requires a gain term.

The upper target requires connection of a 100K Ω resistor. The actual value should be within 10% of 100K Ω .

Calibration of DC resistors

Resistor sensors that use direct current excitation are calibrated by using the **1mA DC**, **100uA DC** and **10uA DC** tabs.

Resistors required for calibration are as follows:

- 1mA DC:** Upper - 100 Ω , Lower - 10 Ω .
- 100uA DC:** Upper 1,000 Ω , Lower - 100 Ω
- 10uA DC:** Upper - 10,000 Ω , Lower - 1,000 Ω .

Calibration of AC resistors

Resistor sensors that use auto-ranged AC excitation are calibrated by using the **1mA AC**, **100uA AC** and **10uA AC** tabs.

Resistors required for calibration are as follows:

- 1mA AC:** Upper - 100 Ω , Lower - 10 Ω .
- 100uA AC:** Upper 1,000 Ω , Lower - 100 Ω
- 10uA AC:** Upper - 10,000 Ω , Lower - 1,000 Ω .

Remote Operation

Remote Interface Configuration

The Model 32 has two remote interfaces: The GPIB (IEEE-488.2) and the RS-232. Connection to these interfaces is made on the rear panel of the instrument. For specifics about the connectors and cables required, refer to the section above on Rear Panel Connections.

Configuration of the remote interfaces is done at the instrument's front panel by using the Remote I/O Setup Menu.

All configuration information shown on this screen is stored in non-volatile memory and, once setup, will not change when power is turned off or a remote interface is reset.

IEEE-488 (GPIB) Configuration

The only configuration parameter for the GPIB interface is to set the address. This is done by using the [System Functions Menu](#) described above.

Note that each device on the GPIB interface must have a unique address. You can set the instrument's address to any value between 1 and 31. The address is set to 12 when the unit is shipped from the factory.

The controller's GPIB interface does not use a termination character, or EOS. Rather, it uses the EOI hardware handshake method to signal the end of a line. Therefore, the host must be configured to talk to the instrument using EOI and no EOS.

Primary Address:	1-31
Secondary Address:	None
Timeout	2S
Terminate Read on EOS	NO
Set EOI with EOS on Writes	YES
EOS byte	N/A

Table 36: Recommended GPIB Host Setup Parameters

RS-232 Configuration

The user can select RS-232 Baud Rates between 300 and 38,400. The factory default is 9600.

The Baud Rate can be changed from the instrument's front panel by using the [SYS menu](#).

Other RS-232 communications parameters are fixed in the instrument. They are set as follows:

Parity: None
Bits: 8
Stop Bits: 1
Mode: Half Duplex

The RS-232 interface uses a "New Line", or Line Feed character as a line termination. In the C programming language, this character is `\n` or hexadecimal `0xA`.

When sending strings to the controller, any combination of the following characters must be sent to terminate the line:

1. Carriage Return, Hex `0xD`.
2. Line Feed, `\n`, Hex `0xA`.
3. Null, `0`.

The controller will always return the `\n` character at the end of each line.

 **Note:** Some serial port software drivers allow the programmer to set a line termination character. This character is then appended to each string sent to the controller and stripped from returned strings. In this case, the `\n` (`0xA`) character should be selected.

Introduction to Remote Programming

Instructions

Instructions (both commands and queries) normally appear as a string embedded in a statement of your host language, such as BASIC or C

Instructions are composed of two main parts: The header, which specifies the command or query to be sent; and the parameters, which provide additional data needed to clarify the meaning of the instruction.

An instruction header is comprised of one or more keywords separated by colons (:). Queries are indicated by adding a question mark (?) to the end of the header. Many instructions can be used as either commands or queries, depending on whether or not you have included the question mark. The command and query forms of an instruction usually have different parameters. Many queries do not use any parameters.

The white space is used to separate the instruction header from the instruction parameters. If the instruction does not use any parameters, you do not need to include any white space. White space is defined as one or more spaces. ASCII defines a space to be character 32 (in decimal).

Instruction parameters are used to clarify the meaning of the command or query. They provide necessary data, such as whether a function should be on or off, which input channel controls the heater output etc. Each instruction's syntax definition shows the parameters, as well as the values they accept.

Headers

There are three types of headers: Simple Command; Compound Command; and Common Command.

Simple command headers contain a single keyword. CONTROL and STOP are examples of single command headers. The syntax is:

`<function><terminator>`

When parameters (indicated by `<data>`) must be included with the simple command header (for example, INPUT CHA) the syntax is:

`<function><white space><data><terminator>`

Compound command headers are a combination of two or more keywords. The first keyword selects the subsystem, and the last keyword selects the function within that subsystem. Sometimes you may need to list more than one subsystem before being allowed to specify the function. The keywords within the compound header are separated by colons. For example:

SYSTEM:AMBIENT?

To execute a single function within a subsystem, use the following:

`:<subsystem>:<function><white space><data><terminator>`

Command headers control IEEE 488.2 defined functions within the instrument (such as clear status, etc.). Their syntax is:

*<command header><terminator>

No space or separator is allowed between the asterisk and the command header. *CLS is an example of a common command header.

To execute more than one function within the same subsystem a semi-colon (;) is used to separate the functions:

:<subsystem>:<function><white space><data>
<function><white space><data><terminator>

Command headers immediately followed by a question mark (?) are queries. After receiving a query, the instrument interrogates the requested function and places the response in its output queue. The output message remains in the queue until it is read or another command is issued.

Query commands are used to find out how the instrument is currently configured. They are also used to get results of measurements

Note: The output queue must be read before the next command is sent. For example, when you send the query, you must follow it with an input statement.

Truncation of Keywords

If a keyword contains more than four characters, it may be truncated to four or less characters to simplify programming.

The truncated form of a keyword is the first four characters of the word, except if the last character is a vowel. If so, the truncated form is the first three characters of the word.

SCPI Status Registers

The Instrument Status Register

The Instrument Status Register (ISR) is queried using the SYSTEM:ISR? command.

The ISR is commonly used to generate a service request (GPIB) when various status conditions occur. In this case, the ISR is masked with the Instrument Status Enable (ISE) register.

The ISR is defined as follows:

ISR

Bit7	Bit6	Bit5	Bit4	Bit3	Bit2	Bit1	Bit0
Alarm			Htr			SFB	SFA

Where:

Bit7 – Alarm: Indicates that an alarm condition is asserted. Use the ALARM commands to query individual alarms.

Bit4 – Htr: Indicates a heater fault condition. Use the HEATER commands to query the heater.

Bit1 to Bit0 – SFx: Indicates that a sensor fault condition is asserted on an input channel. Use the INPUT commands to query the input channels.

The Instrument Status Enable Register

The Instrument Status Enable (ISE) Register is a mask register. It is logically “anded” with the contents of the ISR in order to set the Instrument Event (IE) bit in the Status Byte (STB) register. This can cause a service request (GPIB) to occur.

Bits in the ISE correspond to the bits in the ISR defined above.

The Standard Event Register

The Standard Event Register (ESR) is defined by the SCPI to identify various standard events and error conditions. It is queried using the Common Command *ESR?. This register is often used to generate an interrupt packet, or service request when various I/O errors occur.

Bits in the ESR are defined as follows:

ESR

Bit7	Bit6	Bit5	Bit4	Bit3	Bit2	Bit1	Bit0
OPC		QE	DE	EE	CE		PWR

Where:

Bit7 – OPC: Indicates Operation Complete.

Bit5 – QE: Indicates a Query Error. This bit is set when a syntax error has occurred on a remote query. It is often used for debugging.

Bit4 – DE: Indicates a Device Error.

Bit3 – EE: Indicates an Execution Error. This bit is set when a valid command was received, but could not be executed. An example is attempting to edit a factory supplied calibration table.

Bit2 – CE: Indicates a Command Error. This bit is set when a syntax error was detected in a remote command.

Bit0 – PWR: Indicates power is on.

The Standard Event Enable Register

The Standard Event Enable Register (ESE) is defined by the SCPI as a mask register for the ESR defined above. It is set and queried using the Common Command *ESE.

Bits in this register map to the bits of the ESR. The logical AND of the ESR and ESE registers sets the Standard Event register in the Status Byte (STB).

The Status Byte

The Status Byte (STB) is defined by the SCPI and is used to collect individual status bits from the ESE and the ISR as well as to identify that the instrument has a message for the host in its output queue. It is queried using the Common Command *STB?. Bits are defined as follows:

STB

Bit7	Bit6	Bit5	Bit4	Bit3	Bit2	Bit1	Bit0
	RQS	SE	MAV	IE			

Where:

Bit6 – RQS: Request for Service.

Bit5 – SE: Standard Event. This bit is set as the logical 'AND' of the ESR and ESE registers.

Bit4 – MAV: Message Available

Bit3 – IE: Instrument Event. This bit is set as the logical 'AND' of the ISR and ISE registers.

The Status Byte Register

The Status Enable Register (SRE) is defined by the mask register for the STB. It is set and queried using the Common Commands *SRE.

The logical 'AND' of the SRE and STB registers is used to generate a service request on the GPIB interface.

Remote Commands

IEEE488 SCPI Common commands.

The Common Commands are defined by the IEEE-488.2 standard and are supported by the Model 32 on the GPIB port as well as all of the remote interface ports.

The common commands control some of the basic instrument functions, such as instrument identification and reset. They also provide an instrument status reporting mechanism.

*CLS Clear Status

Clear Status

The *CLS common command clears the status data structures, including the device error queue and the MAV (Message Available) bit.

Command Syntax: *CLS

Command Example: *CLS

*ESE Event Status Enable

Event Status Enable.

The *ESE command sets the Standard Event Status Enable (ESE) Register bits. The ESE Register contains a bit mask for the bits to be enabled in the Standard Event Status (SEV) Register. A one in the ESE register will enable the corresponding bit in the SEV register. A zero will disable the bit.

The *ESE? Query returns the current contents of the ESE register.

Command Syntax: *ESE <mask>

Query Syntax: *ESE?

Command Example: *ESE 32

Query Response: <mask>

This will set the CME, or Command Error, bit enable. Therefore, when a command error occurs, the event summary bit (ESB) in the Status Byte Register will also be set.

Query Example: *ESE?

Query Response: 16

Bit 4, or the Execution Error bit has been enabled. All other standard events are disabled.

***ESR Query Event Status Register**

Query Event Status Register.

The *ESR query returns the contents of the Standard Event (SEV) status register.

Query Syntax: *ESR?

Query Response: <status>

Where status is a number between 0 and 255.

***IDN Query unit Identification**

Query unit identification string.

The *IDN? Query will cause the instrument to identify itself. The Model 32 will return the following string:

“Cryocon Model 32 Rev <firmware rev code><hardware rev code>”

Where <firmware rev code> is the revision level of the unit's firmware and <hardware rev code> is the hardware revision code.

Query Syntax: *IDN?

Query Response: <Instrument Identification String>

***OPC Operation Complete**

The *OPC command will cause the instrument to set the operation complete bit in the Standard Event (SEV) status register when all pending device operations have finished.

The *OPC Query places an ASCII '1' in the output queue when all pending device operations have completed.

Command Syntax: *OPC**Query Syntax:** *OPC?

Query Response: 1

***RST Reset**

Reset the controller. This will cause a hardware reset in the Model 32. The reset sequence will take about 15 seconds to complete. During that time, the instrument will not be accessible over any remote interface.

The *RST command sets the Model 32 to its last power-up default setting.

Command Syntax: *RST

Control Loop Start/Stop commands**STOP Disengage control loops**

The STOP command will disengage all control loops and disconnect their heaters.

Command Syntax: STOP

CONTROL: Engage Control Loops

The CONTROL command will cause the instrument to enter the control mode by activating enabled control loops.

To disable an individual loop, set its control type to OFF.

As a query, the command will report the status of the loops as ON or OFF.

Command Syntax: CONTROL

Command Example: CONT

Query Syntax: CONTROL?

Query Response: <status>

Where <status> is ON or OFF.

Query Example: CONT?

Example Response: OFF

Indicating that the control loops are OFF, or disengaged.

Short Form: CONT

SYSTEM commands

SYSTEM commands are a group of commands associated with the overall status and configuration of the Model 32 rather than a specific internal subsystem.

SYSTEM:LOCKOUT: Keypad Lockout.

Sets or queries the remote lockout status indicator.

This command is used to enable or lock out the front panel keypad of the Model 32, thereby allowing or preventing keypad entry during remote operation.

The default condition for this indicator is OFF.

Command Syntax: SYSTEM:LOCKOUT <status>

Where <status> is either ON or OFF. A <status> of ON will lock out the front panel keypad.

Query Syntax: SYSTEM:LOCKOUT?

Query Response: <status>

Query Example: SYSTEM:LOCKOUT?

Example Response: OFF

Indicating that the front panel keypad is enabled.

Short Form: SYST:LOCK

SYSTEM:NVSAVE Save NVRAM to flash

Save NV RAM to Flash. This saves the entire instrument configuration to flash memory so that it will be restored on the next power-up. Generally only used in environments where AC power is not toggled from the front panel. This includes remote and rack-mount applications.

Command Syntax: SYSTEM:NVSAVE

Short Form: SYST: NVS

SYSTEM:REMLED: Front Panel Remote LED

Sets or queries the remote LED status indicator on the Model 32 front panel.

The default condition for this indicator is OFF.

Note that the Remote LED is automatically handled by the GPIB interface but must be turned on and off when using the RS-232 interface.

Command Syntax: SYSTEM:REMLED <status>

Where <status> is either ON or OFF. A <status> of ON will illuminate the front panel Remote LED

Query Syntax: SYSTEM:REMLED?

Query Response: <status>

Query Example: SYSTEM:REMLED?

Example Response: OFF

Indicating that the Remote LED is OFF.

Short Form: SYST:REML

SYSTEM:LOOP: Control Loop On/Off

Reports the status of the two temperature control loops.

A status of OFF indicates that both loops are disabled and the output power levels are zero. A status of ON indicates that the loops are engaged and actively controlling temperature.

Command Syntax: N/A

The CONTROL command is used to engage the control loops and the STOP command is used to disengage them.

Query Syntax: SYSTEM:LOOP?

Query Response: <status>

Query Example: SYSTEM:LOOP?

Example Response: OFF

Indicating that both control loops are disengaged.

Short Form: SYST:LOOP

SYSTEM:BEEP: Sound the audible alarm

Asserts the audible alarm for a specified number of seconds.

Command Syntax: SYSTEM:BEEP <Sec>

Where <Sec> is the number of seconds to beep the audible alarm.

Command Example: SYSTEM:BEEP 10

Sounds the audible alarm for 10 seconds.

Short Form: SYST:BEEP

SYSTEM:DISTC: Display Filter Time Constant.

The SYSTEM:DISTC command is used to set or query the display filter time constant.

The display filter is applied to all reported or displayed temperature data. Available time constants are 0.5, 1, 2, 4, 8, 16, 32 or 64 Seconds.

Command Syntax: SYSTEM:DISTC <tc>

Where <tc> is the display filter time constant, in seconds, selected from the following list: 0.5, 1, 2, 4, 8, 16, 32, 64.

Query Syntax: SYSTEM:DISTC?

Query Response: <tc>

Command Example: SYSTEM:DISTC 8

This command will set the display time constant to 8 Seconds.

Query Example: SYSTEM:DISTC?

Example Response: 2

Which indicates that the display filter has a 2 Second time constant.

Short Form: SYST:DIST

SYSTEM:ADRS: GPIB address.

Selects the address that the IEEE-488.2 remote interface will use.

The address is a numeric value between 1 and 31. The factory default is address 12.

The addresses assigned to units must be unique on each GPIB bus structure. Multiple units with the same address on a single bus structure will cause errors.

Command Syntax: SYSTEM:ADRS <adrs>

Where <adrs> is the desired unit address. The IEEE-488.2 interface on the Model 32 will be re-initialized using <adrs> as it's address.

Query Syntax: SYSTEM:ADRS?

Query Response: <adrs>

Command Example: SYSTEM:ADRS 14

Sets the Model 32 IEEE-488.2 address to 14.

Query Example: SYSTEM:ADRS?

Example Response: 12

Indicates that the current GPIB address is 12.

Short Form: SYST:ADRS

SYSTEM:REMOTE: Select Remote Interface

Queries or selects the port that the Model 32 will use for all remote communication.

Available ports are:

GPIB for the IEEE-488.2 port.
RS232 for the RS-232 port.

Command Syntax: SYSTEM:REMOTE <port>

Where <port> is the remote port selection. The Model 32 will first disable all remote ports, then initialize and re-enable the selected port.

This command can be used as a port reset.

Query Syntax: SYSTEM:REMOTE?

Query Response: <port>

Command Example: SYSTEM:REMOTE GPIB

Selects the GPIB remote port. If the GPIB is already selected, it is re-initialized and enabled.

Query Example: SYSTEM:REMOTE?

Example Response: RS232

Indicates that the current remote port is RS-232

Short Form: SYST:REMO

SYSTEM:RESEED: Re-seed the display filters

Re-seeds the input channel's averaging filter, allowing the reading to settle significantly faster.

The display filter may have filter time-constants that are very long. The RESEED command inserts the current instantaneous temperature value into the filter history, thereby allowing it to settle rapidly.

Command Syntax: SYSTEM:RESEED

Command Example: SYSTEM:RESEED

Short Form: SYS:RES

<p> Note: The RESEED command is very useful in systems where a computer is waiting for a reading to settle. Issuing the RESEED command will reduce the required settling time of the reading.</p>

SYSTEM:AMBIENT Query Internal Temperature.

The Model 32 incorporates a temperature sensor into its internal voltage reference. This temperature is essentially the internal temperature of the instrument and may be queried using the SYSTEM:AMBIENT command.

Query Syntax: SYSTEM:AMBIENT?

Query Response: <temp>

Where <temp> is the internal temperature of the Model 32 in degrees Celsius.

Query Example: SYSTEM:AMB?

Example Response: +25C

Indicates that the current temperature of the Model 32's internal voltage reference is 25°C.

Short Form: SYST:AMB

Where AMBIENT is truncated to four characters, then to three since the fourth character is a vowel.

SYSTEM:AUTOCAL Automatically recalibrate the input channels.

This command causes the Model 32 to execute an internal recalibration of both input channels. It is useful when the operating temperature has changed significantly. The process takes about ½ second to complete.

Autocalibrate should not be executed when the Model 32 is controlling temperature because it may cause the control loops to disengage.

Command Syntax: SYSTEM:AUTOCAL**Short Form:** SYST:AUT

Where AUTOCAL is truncated to four characters, then to three since the fourth character is a vowel.

SYSTEM:HTRHST: Heater heat sink temperature.

The temperature of the Model 32's internal heater circuit heat sink is continuously monitored and used to initiate the automatic shutdown sequence when a heater fault is detected. This temperature may be queried using the SYSTEM:HTRHST command.

Query Syntax: SYSTEM:HTRHST?

Query Response: <temp>

Where <temp> is the temperature of the internal heater output stage's heat sink in Celsius.

Query Example: SYSTEM:HTRH?

Example Response: +62C

Indicates that the heat sink is at 62°C.

Short Form: SYST:HTRH

SYSTEM:HOME: Display Operate Screen.

Causes the VFD display on the front panel to go to the Operate Screen.

Command Syntax: SYSTEM:HOME

Command Example: SYSTEM:HOME

Short Form: SYST:HOME

SYSTEM:SYNCTAPS: Synchronous filter setup.

Sets or queries the number of taps in the synchronous filter. This is an advanced setup function. The default is 7 taps.

Command Syntax: SYSTEM:SYNCTAPS <taps>

Where <taps> is the number of taps.

Query Syntax: SYSTEM:SYNCTAPS?

Query Response: <taps>

Where <taps> is number of taps used by the synchronous filter.

Query Example: SYSTEM:SYNCTAPS?

Example Response: 7

Short Form: SYST:HTRH

SYSTEM:NAME Unit Name

The controller contains a unit name string that may be set or queried using this command. This can be used to assign a descriptive name to the instrument.

Use the SYSTEM:ADRS command to assign a unique address.

Command Syntax: SYSTEM:NAME <name>

Where <name> is the desired system name string and is a maximum of 15 ASCII characters.

Command Example: SYSTEM:NAME "Cryocooler Four"

This assigns the name "Cryocooler Four" to the unit so that it may be uniquely identified.

Query Syntax: SYSTEM:NAME?

Query Response: <name>

Where <name> is the temperature of the internal heater output stage's heat sink in Celsius.

Query Example: SYSTEM:NAME?

Example Response: Model 32 Unit 0

Short Form: SYST:NAM

SYSTEM:HWREV: Instrument Hardware Revision Level

Queries the instrument's hardware revision level.

Query Syntax: SYSTEM:HWREV?

Query Example: SYSTEM: HWREV?

Example Response: A

Indicating that the instrument's hardware is revision level A.

Short Form: SYST:HWR

SYSTEM:FWREV: Instrument Firmware Revision Level

Queries the instrument's firmware revision level.

Query Syntax: SYSTEM:FWREV?

Query Example: SYSTEM:FWREV?

Example Response: 3.18

Indicating that the instrument's firmware is revision level 3.18.

Short Form: SYST:FWR

SYSTEM:LINEFREQ: AC Power Line Frequency.

Sets or queries the AC Power Line frequency setting.

Command Syntax: SYSTEM:LINEFREQ <freq>

Where <freq> is the AC Power Line Frequency and may be either 50 or 60 for 50Hz or 60Hz.

Command Example: SYSTEM:LINEFREQ 60

Sets the AC Power Line Frequency setting to 60 Hz.

Query Syntax: SYSTEM: LINEFREQ?

Query Response: <freq>

Where <freq> is the line frequency setting

Query Example: SYSTEM: LINEFREQ?

Example Response: 50

Short Form: SYST:LIN

SYSTEM:DRES: Display Resolution.

Sets or queries the controller's display resolution. Choices are:

FULL: The VFD will display temperature with the maximum possible resolution.

1, 2 or 3: The VFD display will display the specified number of digits to the right of the decimal point.

NOTE: This command only sets the number of digits displayed on the front panel VFD. It does NOT affect the internal accuracy of the instrument or the format of measurements reported on the remote interfaces.

The main use for this command is to eliminate the flicker in low order digits when the controller is used in a noisy environment.

Command Syntax: SYSTEM:DRES <res>

Where <res> is the display resolution as follows: FULL, 1, 2, 3.

Command Example: SYSTEM:DRES 2

Causes the VFD display to show temperature with two digits to the right of the decimal point..

Query Syntax: SYSTEM:DRES?

Query Response: <res>

Where <res> is the display resolution

Query Example: SYSTEM:DRES?

Example Response: FULL

Short Form: SYST:DRES

SYSTEM: PUCONTROL: Power up in control mode

Sets or queries the controller's power up in control mode setting.

Reference the section on [power up in control mode](#). Default is OFF.

Command Syntax: SYSTEM:PUCONTROL <mode>
Where <mode> is ON or OFF

Command Example: SYSTEM: PUCONTROL OFF
Causes the power up in control mode setting to select OFF.

Query Syntax: SYSTEM:PUCONTROL?
Query Response: <mode>
Where <mode> is ON or OFF

Query Example: SYSTEM:PUC?
Example Response: OFF

Short Form: SYST:PUC

CONFIG commands

The CONFIG commands are used to save and restore any of the six available user instrument setups. Each setup contains the complete state of the controller.

CONFIG:NAME: User Setup Name

Instrument setups can be named for user convenience. The CONFIG:NAME command sets and queries the user configuration names.

Command Syntax: CONFIG <ix>:NAME <name>

Where <ix> is the index number of the desired instrument setup. Values may be 0 through 3. <name> is the desired name string and is a maximum of 15 ASCII characters.

Command Example: CONFIG 3:NAME "Product Alpha"

This assigns the name "Product Alpha" to instrument setup #3.

Query Syntax: CONFIG <ix>:NAME?

Query Response: <name>

Where <name> is the temperature of the internal heater output stage's heat sink in Celsius.

Query Example: CONFIG 0 NAME?

Example Response: "Dewar Two"

Short Form: CONFIG:NAM

CONFIG:SAVE: Save User Configuration.

Saves an the current instrument setup to a user setup.

Command Syntax: CONFIG <ix>:SAVE

Where <ix> is the index number of the desired instrument setup. Values may be 0 through 5.

Command Example: CONFIG 1:SAVE

Saves the controller's current setup to user setup #1.

Short Form: CONFIG:SAV

CONFIG:RESTORE: Restore User Configuration.

Restores a previously stored user instrument setup.

Command Syntax: CONFIG <ix>:RESTORE

Where <ix> is the index number of the desired instrument setup. Values may be 0 through 5.

Command Example: CONFIG 0:RESTORE

Restores the controller's setup from user setup #0.

Short Form: CONFIG:REST

INPUT commands

The INPUT group of commands are associated with the configuration and status of the four input channels.

INPUT may also be a stand alone query.

Parameter references to the input channels may be:

- Numeric ranging in value from zero to two.
- Channel ID tags including CHA or CHB.
- Alphabetic including A or B.

INPUT: Input Channel Temperature Query.

The INPUT query reports the current temperature reading on any of the input channels.

Temperature is filtered by the display time constant filter and reported in display units.

Query Syntax: INPUT ? <channel>

Where <channel> is the input channel parameter.

Query Response: <temp>

Where <temp> is the temperature of the specified input channel in display units (K, F, C or S). Floating Point string.

Query Example: INPUT? B

Example Response: 123.4567

Alternate Form: INPUT <channel>:TEMP?**Short Form:** INP

INPUT:TEMPER: Input Temperature.

The INPUT:TEMPER query is identical to the input query described above. It reports the current temperature reading on any of the input channels.

Temperature is filtered by the display time constant filter and reported in display units.

Query Syntax: INPUT <channel>:TEMPER?

Where <channel> is the input channel parameter.

Query Response: <temp>

Where <temp> is the temperature of the specified input channel in display units (K, F, C or S). Floating Point string.

Query Example: INP B:TEMP?

Example Response: 12.45933

Short Form: INP <channel>:TEMP?**INPUT:UNITS Input channel units**

Sets or reports the display units of temperature used by the specified input channel.

Command Syntax: INPUT <channel>:UNITS <units>

Where <channel> is the input channel parameter and <units> is the display units indicator.

<units> may be K for Kelvin, C for Celsius, F for Fahrenheit or S for primitive sensor units. In the case of sensor units, the instrument will determine if the actual units are Volts or Ohms based on the actual sensor type selected for the input channel.

Query Syntax: INPUT <channel>:UNITS?

Where <channel> is the input channel indicator.

Query Response: <units>

Where <units> is the display units indicator which will be K, C, F, V for Volts or O for Ohms.

Command Example: INPUT B:UNITS F**Query Example:** INP A:UNIT?

Example Response: K

Query Example: INP A:TEMP?;UNIT?

Example Response: 27.9906K

Short Form: INP:UNIT

INPUT:SENPR: Input Reading in Sensor Units.

The INPUT:SENPR query reports the reading on a selected input channel. For diode and thermocouple sensors, the reading is in Volts while resistor sensors are reported in Ohms

The reading is not filtered by the display time-constant filter. However, the synchronous input filter has been applied.

Query Syntax: INPUT <channel>:SENPR?

Where <channel> is the input channel parameter of A or B.

Query Response: <rdg>

Where <rdg> is the reading of the specified input channel in Ohms or Volts

Query Example: INP B:SENPR?

Example Response: 124.5933 meaning 124.5933 Ohms

Short Form: INP <channel>:SENPR?**INPUT:VBIAS Input channel sensor bias voltage**

Sets or queries the constant-voltage mode voltage used on the specified input channel. This value only applies to sensors that use constant-voltage excitation. They are indicated by a sensor type of ACR.

If this query is used with a sensor type other than ACR, it will always return N/A for not applicable.

Command Syntax: INPUT <channel>:VBIAS <volts>

Where <channel> is the input channel parameter and <volts> is the bias voltage. Choices are:

10mV – 10milliVolt.

3.3mV – 3.33milliVolt.

1mV – 1.0milliVolt.

Query Syntax: INPUT <channel>:VBIAS?

Where <channel> is the input channel indicator.

Query Response: <volts>

Command Example: INPUT B:VBIAS 3.3mV**Query Example:** INP A:VBias?

Example Response: 1.0mV. Note: if the sensor on channel A is not a type ACR, the response will always be N/A.

Short Form: INP:VBIAS

INPUT:ISENIX Installed Sensor index

Sets or queries the sensor index number assigned to an input channel for factory installed sensors.

Sensor index zero indicates that there is no sensor connected to the selected input channel. This will disable all readings on the channel.

Refer to [Appendix A](#) for a description of sensors, indices etc.

Note: The use of the ISENIX command to assign a factory-installed sensor and the USENIX command to assign a user sensor are preferred to the use of the obsolete SENIX command.

The SENTYPE command may be used to query the name of a factory-installed sensor at a specific index.

Command Syntax: INPUT <channel>:ISENIX <ix>

Where <channel> is the input channel parameter and <ix> is the desired sensor index.

Query Syntax: INPUT <channel>:ISENIX?

Where <channel> is the input channel indicator.

Query Response: <ix>

Where <ix> is the sensor index for the selected input channel. If the index is invalid, a value of -1 will be returned.

Command Example: INPUT B:SENIX 0

This command sets the sensor index for input channel B to zero (disabled).

Query Example: INP A:SENIX?

Example Response: 02

This indicates that sensor 02 is assigned to input channel A. The name of factory installed sensor 02 may be accessed using the SENTYPE commands.

Short Form: INP:SEN

INPUT:USENIX User Sensor index

Sets or queries the sensor index number assigned to an input channel for user installed sensors.

Refer to [Appendix A](#) for a description of sensors, indices etc.

An index number of 0 through 3 indicates user sensor curves 0 through 3.

Note: The use of the ISENIX command to assign a factory installed sensor and the USENIX command to assign a user sensor are preferred to the use of the obsolete SENIX command.

The CALD command may be used to query information about the user installed sensor curves.

Command Syntax: INPUT <channel>:USENIX <ix>

Where <channel> is the input channel parameter and <ix> is the desired sensor index.

Query Syntax: INPUT <channel>:USENIX?

Where <channel> is the input channel indicator.

Query Response: <ix>

Where <ix> is the sensor index for the selected input channel. If the index is outside of the range 0 through 3, a value of -1 will be returned.

Command Example: INPUT B:USENIX 0

This command sets the sensor index for input channel B to zero (disabled).

Query Example: INP A:USENIX?

Example Response: 2

This indicates that sensor 02 is assigned to input channel A.

Short Form: INP:SEN

INPUT:SENIX Sensor index (obsolete)

Sets or queries the sensor index number assigned to an input channel. This command is used to assign the sensor type to a channel. Sensor types and configurations are accessed using the SENTRY commands.

Sensor index zero indicates that there is no sensor connected to the selected input channel. This will disable all readings on the channel.

Refer to [Appendix A](#) for a description of sensors, indices etc.

Note: To ensure portability of software written for the Model 32, you should use the ISENIX command to assign a factory installed sensor or USENIX to assign a user sensor. This way, the index will always correspond to the correct sensor regardless of the Model 32 firmware revision.

Command Syntax: INPUT <channel>:SENIX <ix>

Where <channel> is the input channel parameter and <ix> is the desired sensor index.

Query Syntax: INPUT <channel>:SENIX?

Where <channel> is the input channel indicator.

Query Response: <ix>

Where <ix> is the sensor index for the selected input channel.

Command Example: INPUT B:SENIX 0

This command sets the sensor index for input channel B to zero (disabled).

Query Example: INP A:SENIX?

Example Response: 02

This indicates that sensor 02 is assigned to input channel A. The name and configuration of sensor 02 may be accessed using the SENTRY commands.

Short Form: INP:SEN

INPUT:ALARM?: Input Channel Alarm Status.

Queries the alarm status of the specified input channel. Status is a two character string where:

--	indicates that no alarms are asserted
SF	indicates a Sensor Fault condition.
HI	indicates a high temperature alarm
LO	indicates a low temperature alarm.

There is a 0.25K hysteresis in the assertion of a high or low temperature alarm condition.

The user selectable display time constant filter is applied to input channel temperature data before alarm conditions are tested.

Query Syntax: INPUT <channel>: ALARM?

Query Response: <alarm>

Where <channel> is the input channel indicator and <alarm> is the alarm status indicators for that channel.

Query Example: INP A:ALARM?

Example Response: --

Which indicates that no alarm is asserted for input channel A.

Short Form: INP <channel>:ALAR?

INPUT:ALARM:HIGHEST: Alarm High Setpoint.

Sets or queries the temperature setting of the high temperature alarm for the specified input channel. When this temperature is exceeded, an enabled high temperature alarm condition will be asserted.

Temperature is assumed to be in the display units of the selected input channel.

There is a 0.25K hysteresis in the assertion of a high or low temperature alarm condition.

Command Syntax: INPUT <channel>:ALARM:HIGHEST <temp>

Where <channel> is the input channel indicator and <temp> is the alarm setpoint temperature. . Temperature is a floating point string that may be up to 20 characters.

Query Syntax: INPUT <channel>: ALARM:HIGHEST?

Query Response: <temp>

Where <channel> is the input channel indicator and <temp> is the temperature setting of the high temperature alarm for <channel>. Temperature is reported to the full precision of 32 bit floating point.

Command Example: INP A:ALARM:HIGH 200.5

Sets the high temperature alarm setpoint for input channel A to 200.5.

Query Example: INP A:ALARM:HIGHEST?

Example Response: 125.4321

If the display units setting for input channel A are Kelvin, this response is also in units of Kelvin.

Short Form: INP <channel>:ALAR:HIGH

INPUT:ALARM:LOWEST: Alarm Low Setpoint.

Sets or queries the temperature setting of the low temperature alarm for the specified input channel. When the input channel temperature is below this, an enabled low temperature alarm condition will be asserted.

Temperature is assumed to be in the display units of the selected input channel.

There is a 0.25K hysteresis in the assertion of a high or low temperature alarm condition.

Command Syntax: INPUT <channel>:ALARM:LOWEST <temp>

Where <channel> is the input channel indicator and <temp> is the alarm setpoint temperature. Temperature is a floating point string that may be up to 20 characters.

Query Syntax: INPUT <channel>:ALARM:LOWEST?

Query Response: <temp>

Where <channel> is the input channel indicator and <temp> is the temperature setting of the low temperature alarm for <channel>. Temperature is reported to the full precision of 32 bit floating point.

Command Example: INP A:ALARM:LOW 100.5

Sets the low temperature alarm setpoint for input channel A to 100.5.

Query Example: INP B:ALARM:LOW?

Example Response: 25.43210

If the display units setting for input channel B are Celsius, this response is also in units of Celsius.

Short Form: INP <channel>:ALAR:LOW

INPUT:ALARM:HIENA: Alarm High Enable.

Sets or queries the high temperature alarm enable for the specified input channel.

An alarm must be enabled before it can be asserted.

Command Syntax: INPUT <channel>:ALARM:HIENA <status>

Where <channel> is the input channel indicator and <status> is the status of the high temperature alarm enable. <status> may be either YES or NO.

Query Syntax: INPUT <channel>:ALARM:HIENA?

Query Response: <status>

Where <channel> is the input channel indicator and <status> is the setting of the high temperature alarm enable for <channel>. <status> will be either YES or NO.

Command Example: INPUT A:ALARM:HIENA NO

Disables the high temperature alarm for input channel A.

Query Example: INP B:ALARM:HIEN?

Example Response: YES

Query / Command Example: INP B:ALARM:HIGH?;HIEN NO

Example Response: 154.2323

The high temperature alarm setpoint for channel B is reported then the high temperature alarm for channel B is disabled.

Short Form: INP <channel>:ALAR:HIEN

INPUT:ALARM:LOENA: Alarm Low Enable.

Sets or queries the low temperature alarm enable for the specified input channel.

An alarm must be enabled before it can be asserted.

Command Syntax: INPUT <channel>:ALARM:LOENA <status>

Where <channel> is the input channel indicator and <status> is the status of the low temperature alarm enable. <status> may be either YES or NO.

Query Syntax: INPUT <channel>: ALARM:LOENA?

Where <channel> is the input channel indicator.

Query Response: <status>

Where <status> is the setting of the low temperature alarm enable for <channel>. <status> will be either YES or NO.

Command Example: INPUT A:ALARM:LOENA YES

Enables the low temperature alarm for input channel A.

Query Example: INP B:ALARM:LOEN?

Example Response: NO

Query Example: INP B:ALARM:HIENA?;LOENA?

Example Response: YES;NO

The high temperature alarm enable for input channel B is reported followed by the low temperature alarm enable.

Short Form: INP <channel>:ALAR:LOEN

INPUT:ALARM:FAULT: Alarm on Sensor Fault.

Sets or queries the sensor fault alarm enable for the specified input channel.

An alarm must be enabled before it can be asserted.

Command Syntax: INPUT <channel>:ALARM:FAULT <status>

Where <channel> is the input channel indicator and <status> is the status of the sensor fault alarm enable. <status> may be either YES or NO.

Query Syntax: INPUT <channel>: ALARM:FAULT?

Where <channel> is the input channel indicator.

Query Response: <status>

Where <status> is the setting of the sensor fault alarm enable for <channel>. <status> will be either YES or NO.

Command Example: INPUT A:ALARM:FAULT YES

Enables the sensor fault alarm for input channel A.

Query Example: INP B:ALARM:FAULT?

Example Response: NO

Indicating that the sensor fault alarm enable for channel B is disabled.

Query Example: INP B:ALARM:HIENA?;LOENA?;FAULT?

Example Response: YES;NO;NO

Indicates that channel B high temperature alarm is enabled, low temperature alarm is disabled and sensor fault alarm is disabled.

Short Form: INP <channel>:ALAR:FAUL

INPUT:ALARM:AUDIO: Audible Alarm Enable.

The Model 32 contains an audible alarm. This alarm may be optionally sounded when any alarm condition is asserted.

The INPUT:ALARM:AUDIO command is used to set or query the audible alarm enable for the selected input channel.

Command Syntax: INPUT <channel>:ALARM:AUDIO <status>

Where <channel> is the input channel indicator and <status> is the status of the audible alarm enable. <status> may be either YES or NO.

Query Syntax: INPUT <channel>:ALARM:AUDIO?

Where <channel> is the input channel indicator.

Query Response: <status>

Where <status> is the setting of the audible alarm enable for <channel>. <status> will be either YES or NO.

Command Example: INPUT A:ALARM:AUDIO YES

Enables the audible alarm for input channel A alarm conditions.

Command Example: INPUT A:ALARM:HIEN OFF;AUDIO OFF

This command will disable the high temperature alarm and disable the audio alarm for input channel A.

Query Example: INP B:ALARM:AUDIO?

Example Response: NO

Short Form: INP <channel>:ALAR:AUD?

Where AUDIO can be truncated to four characters, then to three characters because the fourth character is a vowel.

INPUT:MINIMUM: Statistical Minimum.

Queries the minimum temperature that has occurred on an input channel since the STATS:RESET command was issued.

Query Syntax: INPUT <channel>: MINIMUM?

Where <channel> is the input channel indicator.

Query Response: <temp>

Where <temp> is the minimum temperature.

Query Example: INP B:MIN?

Example Response: 90.2322

Short Form: INP <channel>:MIN?

INPUT:MAXIMUM MAXIMUM Statistical Maximum.

Queries the Maximum temperature that has occurred on an input channel since the STATS:RESET command was issued.

Query Syntax: INPUT <channel>: MAXIMUM?

Where <channel> is the input channel indicator.

Query Response: <temp>

Where <temp> is the maximum temperature.

Query Example: INP B:MAX?

Example Response: 90.2322

Short Form: INP <channel>:MAX?

INPUT:VARIANCE: Statistical Variance.

Queries the temperature variance that has occurred on an input channel since the STATS:RESET command was issued.

Variance is calculated as the Standard Deviation squared.

Query Syntax: INPUT <channel>: VARIANCE?

Where <channel> is the input channel indicator.

Query Response: <temp>

Where <temp> is the statistical variance of temperature.

Query Example: INP B:VAR?

Example Response: 1.2223

Short Form: INP <channel>:VAR?**INPUT:SLOPE: Slope of best-fit straight line.**

Queries the input channel statistics. SLOPE is the slope of the best fit straight line passing through all temperature samples that have been collected since the STATS:RESET command was issued.

SLOPE is in degrees per Minute.

Query Syntax: INPUT <channel>: SLOPE?

Where <channel> is the input channel indicator.

Query Response: <temp>

Where <temp> is the temperature slope.

Query Example: INP B:SLOPE?

Example Response: 1.2323

Short Form: INP <channel>:SLOP?

INPUT:OFFSET: Offset of best-fit straight line.

Queries the input channel statistics. OFFSET is the offset of the best fit straight line passing through all temperature samples that have been collected since the STATS:RESET command was issued.

OFFSET is in degrees.

Query Syntax: INPUT <channel>: OFFSET?
Where <channel> is the input channel indicator.

Query Response: <temp>
Where <temp> is the temperature offset.

Query Example: INP B: OFFSET?
Example Response: 124.25

Short Form: INP <channel>:OFFS?

INPUT:TIME? Accumulation time

Queries the time duration over which input channel statistics have been accumulated.

TIME is reset by issuing the INPUT:RESET command.

Query Syntax: INPUT <channel>:TIME?
Where <channel> is the input channel indicator.

Query Response: <time>
Where <time> is the time, in Seconds, that has elapsed since the channel statistics were reset.

Query Example: INPUT A:TIME?
Example Response: 232
Indicating 232 seconds have elapsed.

Short Form: INP:TIM?

INPUT:RESET Reset Statistics

Resets the accumulation of input channel statistical data.

Command Syntax: INPUT <channel>:RESET
Resets the accumulation of input channel statistics.

Command Example: INPUT <channel>:RESET

Short Form: INP:RES

LOOP commands

Loop commands are used to configure and monitor Model 32's control loops.

Note: LOOP 1 may also be referred to as HEATER and LOOP 2 may be referred to as LOOP #2.

Loop 1 is the controller's primary heater output channel. In the Model 32 and 32B, this is a 50/25 Watt, three range linear heater.

Loop 2 is a secondary output. In the Model 32, this is a 0-5V voltage output that can drive a strip-chart recorder or a booster power supply. Loop 2 of the Model 32B is a 10 Watt, single range linear heater.

LOOP:SOURCE: Control loop Source Input Channel.

Sets and queries the selected control loop's controlling input channel.

Command Syntax: LOOP <no>:SOURCE <chan>

Where <no> is the loop number, 1 or 2, and <chan> is the designator of the controlling input channel.

Query Syntax: LOOP <no>::SOURCE?

Query Response: <chan>

Where <chan> is the designator of the controlling input channel.

Command Example: LOOP 1:SOUR CHA

Sets the control loop feedback loop to be controlled by input channel A.

Command Example: LOOP 1:SOUR CHB;SETPT 123.4;PGAIN 120

This command will set control loop 1's setpoint to 123.4, the proportional gain term to 120 and the control input channel to B.

Query Example: LOOP 2:SOURCE?

Example Response: CHB

Which indicates that the control loop 2 is being controlled by input channel B.

Short Form: LOOP:SOUR

LOOP:SETPT: Control loop Setpoint.

Sets and queries the selected control loop's setpoint. This is a numeric value that has units determined by the display units of the controlling input channel.

Allowed values are 0K to 1000K.

Command Syntax: LOOP <no>:SETPT <temp>

Where <no> is the loop number, 1 or 2, and <temp> is the desired setpoint.

Query Syntax: LOOP 1:SETPT?

Query Response: <temp>

Where <temp> is the setpoint temperature in units of the controlling input channel.

Command Example: LOOP 1:SETPT 100.4

Sets loop 1's setpoint to 100.4. If the controlling input channel units are Kelvin, this command will result in a setpoint of 100.4K.

Multiple Command Example: LOOP 2:SETPT 123.4;PGAIN 120

This command will set the loop 2 setpoint to 123.4 and the proportional gain term to 120.

Query Example: LOOP 1:SETPT?

Example Response: 143.1293

Short Form: LOOP:SETP

LOOP:TYPE: Control loop Control Type.

Sets and queries the selected control loop's control type. Allowed values are:

- Off** - loop disabled
- PID** - loop control type is PID
- Man** - loop is manually controlled
- Table** - loop is controlled by PID Table lookup.
- RampP** - loop is controlled by PID, but is in ramp mode.

Command Syntax: LOOP <no>:TYPE <type>

Where <no> is the loop number, 1 or 2, and <type> is the loop's control type from the above list.

Query Syntax: LOOP <no>:TYPE?

Query Response: <type>

Where <type> is the loop type from the above list.

Command Example: LOOP 1:TYPE PID

Sets the loop 1 control mode to PID.

Query Example: LOOP 1:TYPE?

Example Response: TABLE

Which indicates that the Loop 1 is controlling based on PID Table lookup.

Short Form: LOOP:TYPE

LOOP:TABLEIX: Control loop PID Table number

Sets and queries the number of the PID table used when controlling in **Table** mode. Six PID tables are available to store PID parameters vs. setpoint.

Command Syntax: LOOP <no>:TABLEIX <number>

Where <no> is the loop number, 1 or 2, and <number> is the loop's control PID table number.

Query Syntax: LOOP <no>:TABLEIX?

Query Response: <number>

Where <number> is the PID table number.

Command Example: LOOP 1:TABLEIX 5

Sets the loop 1 PID table to table number 5.

Query Example: LOOP 1:TABLE?

Example Response: 3

Which indicates that the Loop 1 is controlling based on PID Table number 3.

Short Form: LOOP:TYPE

LOOP 1:RANGE: Control Loop 1 Output Range.

Sets or queries the control loop #1, or the primary heater, output range.

Range determines the maximum output power available and is different for a 50 Ω load resistance than for a 25 Ω load.

Values of heater range are: Hi, Mid and Low. These correspond to the output power levels shown here.

Range	50 Ω Load	25 Ω Load
Hi	50W	25W
Mid	5W	2.5W
Low	0.5W	0.25W

Command Syntax: LOOP 1:RANGE

<range>

Where <range> is the desired heater output range from the above list.

Query Syntax: LOOP 1:RANGE?

Query Response: <range>

Command Example: LOOP 1:RANGE LOW

Sets the heater power output range to Low.

Query Example: LOOP 1:RANGE?

Example Response: Hi

Short Form: LOOP:RANG

LOOP:RAMP?: Control Loop Ramp Status.

Queries the unit to determine if a temperature ramp is in progress on the specified control loop.

Note that temperature ramps on the Loop 1 and Loop 2 channels are independent of each other.

Command Syntax: N/A

Query Syntax: LOOP <no>:RAMP?

Where <no> is the loop number, 1 or 2.

Query Response: ON or OFF.

Query Example: LOOP 2:RAMP?

Example Response: OFF

Short Form: LOOP:RAMP

LOOP:RATE: Control Loop Ramp Rate.

Sets and queries the ramp rate used by the selected control loop when performing a temperature ramp. Rate is in Units per Minute.

Command Syntax: LOOP <no>:RATE <Value>

Where <no> is the loop number, 1 or 2, and <Value> is the ramp rate in Units / Minute. This may be a value between 0 and 100.

Command Example: LOOP 1:RATE 0.02

This will set the loop 1 temperature ramp rate to 0.02. If the controlling input channel has units of Kelvin, the heater rate will be set to 0.02K/min.

Query Syntax: LOOP <no>:RATE?

Query Response: <Value>

Query Example: LOOP 2:RATE?

Example Response: 0.0100

Short Form: LOOP:RAMP

LOOP:PGAIN: Control Loop Proportional Gain term.

Sets or queries the selected control loop's proportional gain term. This is the P term in PID and is a unit-less numeric field with values between 0 (off) and 1000.

The P gain term is applied to the control loop when controlling in a PID mode.

Command Syntax: LOOP <no>:PGAIN <value>

Where <no> is the loop number, 1 or 2, and <value> is the desired P term for the control loop.

Query Syntax: LOOP <no>:PGAIN?

Query Response: <value>

Command Example: LOOP 1:PGAIN 123

Sets the heater P term to 123

Query Example: LOOP 1:PGAIN?

Example Response: 0.49723

Short Form: LOOP:PGA

LOOP:IGAIN: Control Loop Integral Gain term.

Sets and queries the integrator gain term used by the selected control loop. This is a numeric field with units of seconds. Allowed values are 0 (off) through 1000 seconds.

The integrator gain term is applied to the selected control loop when controlling in a PID mode.

Command Syntax: LOOP <no>:IGAIN <value>

Where <no> is the loop number, 1 or 2, and <value> is the desired Integral Gain term for the control loop in seconds.

Query Syntax: LOOP <no>:IGAIN?

Query Response: <value>

Command Example: LOOP 1:IGAIN 12.422

Sets the Loop 1 integrator feedback term to 12.422 Seconds.

Query Example: LOOP 2:IGAIN?

Example Response: 18.23

Indicates that the Loop 2 channel I feedback term is 18.23 Seconds.

Short Form: LOOP:IGA

LOOP:DGAIN: Control Loop Derivative Gain term.

Sets and queries the differentiator gain term used by the selected control loop. This is a numeric field with units of inverse seconds. Allowed values are 0 (off) through 1000/Seconds.

The D gain term is applied to the selected control loop when controlling in a PID mode.

Note: Use of the D gain term can add significant noise. In most cryogenic applications, it is set to zero.

Command Syntax: LOOP <no>:DGAIN <value>

Where <no> is the loop number, 1 or 2, and <value> is the desired D term for the selected control loop in inverse Seconds.

Query Syntax: LOOP <no>:DGAIN?

Query Response: <value>

Command Example: LOOP 1:DGAIN 4.3

Sets control loop 1 differentiator feedback term to 4.3/Seconds.

Query Example: LOOP 1:DGAIN?

Example Response: 8.23

Indicates that the D feedback term for loop 1 is 8.23/Seconds.

Short Form: LOOP:DGA

LOOP:OUTPWR: Control loop Output Power.

Queries the output power of the selected control loop. This is a numeric field that is a percent of full scale.

Query Syntax: LOOP <no>:OUTPWR?

Where <no> is the loop number, 1 or 2.

Query Response: <value>

Where <value> is the selected control loop output power setting in percent.

Query Example: LOOP 2:OUTP?

Example Response: 75.000

Indicates that the control loop 2 is attempting to output 75% of full scale power.

Short Form: LOOP:OUTP

LOOP:HTRREAD?: Heater read back current.

Queries the actual output power of either control loop.

The output current of the heaters in the Model 32 is continuously monitored by an independent read-back circuit. Read-back power will be reported as a percent of full scale. The absolute value of full scale is determined by the selected heater range as shown in this table.

Note that the read-back value is a percent of full-scale power. To compute the output current, you must first compute the square-root of the read-back value.

Heater Range	Full Scale Current
50 / 25 Watt	1.0A
5 / 2.5 Watt	0.333A
0.5 / 0.25 Watt	0.1A

When using the second control loop of the Model 32B, the read-back value is always a percentage of 10 Watts.

Query Syntax: LOOP <no>:HTRREAD?

Where <no> is the loop number, 1 or 2.

Query Response: <current>

Where <current> is the heater output current as a percent of full scale.

Query Example: LOOP 1:HTRR?

Example Response: 33%

Indicates that the heater output current has been measured at 33% of full scale by the heater read-back circuit. If the heater's maximum output power is 50 Watts, the output power is $50 * 0.33 = 16.5$ Watts. This corresponds to an output current of $1.0A * \sqrt{0.33} = 0.57A$

Short Form: LOOP:HTRR

LOOP 1:LOAD: Heater Load Resistance Select.

Sets or queries the load resistance setting of the primary heater (Loop 1). Selections are:

50 for a 50Ω load and a 50W maximum output power.

25 for a 25Ω load and a 25W maximum output power.

Note: Loop 2 of the Model 32B controller always assumes a 50Ω load.

Command Syntax: LOOP 1:LOAD <load>

Where <load> is the desired resistance of the selected control loop load from the above list.

Query Syntax: LOOP 1:LOAD?

Query Response: <LOAD>

Command Example: LOOP 1:LOAD 50

Sets the primary heater output for a 50Ω load.

Query Example: LOOP 1:LOAD?

Example Response: 25

Short Form: LOOP:LOAD

LOOP : MAXPWR: Heater Maximum Output Power.

Sets or queries the maximum output power setting of the selected control loop.

Please refer to the discussion on [maximum output power](#) in the [Control Loop Setup Menu](#) section.

Command Syntax: LOOP <no>:MAXPWR <MaxPwr>

Where <no> is the loop number and <MaxPwr> is the desired maximum output power limit expressed as a percentage of full scale.

Query Syntax: LOOP <no>::MAXPWR?

Query Response: <MaxPwr>

Command Example: LOOP 1:MAXPWR 50

Sets the maximum output power limit on loop 1 to 50% of full scale.

Query Example: LOOP 1:MAXPWR?

Example Response: 25

Short Form: LOOP:MAXP

LOOP : MAXSET: Control Loop Maximum Setpoint.

Sets or queries the maximum allowed set point for the selected control loop.

Please refer to the discussion on [Maximum Setpoint](#) in the [Control Loop Setup Menu](#) section.

Setpoint units are the currently selected display units for the controlling input channel.

Command Syntax: LOOP <no>:MAXSET <MaxSet>

Where <no> is the loop number and <MaxSet> is the desired maximum set point.

Query Syntax: LOOP <no>::MAXSET?

Query Response: <MaxSet>

Command Example: LOOP 1:MAXSET 300

Sets the maximum allowed setpoint on Loop 1 to 300.

Query Example: LOOP 1:MAXSET?

Example Response: 250

Short Form: LOOP:MAXS

LOOP:PMANUAL: Control Loop Manual Power Output Setting.

Sets and queries the output power level used by the selected control loop feedback when it is in Manual control mode. This value may be changed at any time, but is only used during Manual operation.

PMANUAL is a numeric field that is a percent of full scale selected control loop output current. Actual selected control loop output power will depend on the selected control loop range setting.

Command Syntax: LOOP <no>:PMANUAL <value>

Where <no> is the loop number, 1 or 2, and <value> is the desired selected control loop output current as a percent of full scale.

Query Syntax: LOOP <no>:PMANUAL?

Query Response: <value>

Where <value> is the desired output power as a percent of full scale.

Command Example: LOOP 1:PMAN 50

Sets the control loop 1's output power to 50% of full scale when the loop is in manual control mode.

Query Example: LOOP 1:PMAN?

Example Response: 25.000

Indicates that loop 1 has a manual output power setting of 25%.

Short Form: LOOP:PMAN

OVERTEMP commands

These commands are associated with the heater's Over Temperature Disconnect feature.

This feature is used to disconnect the heater if a specified temperature is exceeded on a selected input channel.

OVERTEMP:ENABLE: OTD Enable.

Sets and queries the over temperature disconnect enable.

Command Syntax: OVERTEMP:ENABLE <enab>

Where <enab> is the desired enable status, which may be ON or OFF.

Query Syntax: OVERTEMP:ENABLE?

Query Response: <enab>

Where <enab> is the status of the over temperature disconnect enable.

Command Example: OVERTEMP:ENABLE OFF

Sets the over temperature disconnect feature to OFF.

Query Example: OVERTEMP:ENABLE?

Example Response: YES

Indicating that the over temperature disconnect feature is enabled

Short Form: OVER:ENAB

OVERTEMP:SOURCE: OTD Source Input Channel.

Sets and queries the input channel that is used as the source for the Over Temperature Disconnect feature.

Command Syntax: OVERTEMP:SOURCE <chan>

Where <chan> is the designator of the controlling input channel.

Query Syntax: OVERTEMP:SOURCE?

Query Response: <chan>

Where <chan> is the designator of the input channel.

Command Example: OVER:SOUR A

Sets the over temperature disconnect to monitor channel ChA.

Query Example: OVERTEMP:SOURCE?

Example Response: CHB

Which indicates that the over temperature disconnect is set to monitor input channel ChB.

Short Form: OVER:SOUR

OVERTEMP:TEMP: OTD Maximum Temperature.

Sets and queries the temperature used by the over temperature disconnect feature.

Note that this temperature has the same units of the source input channel.

Command Syntax: OVERTEMP:TEMP <temp>

Where <temp> is the desired temperature.

Query Syntax: OVERTEMP:TEMP?

Query Response: <temp>

Where <temp> is the setpoint temperature in units of the controlling input channel.

Command Example: OVER:TEMP 123.4

Sets the over temperature disconnect to trip when a temperature of 123.4 is exceeded..

Query Example: OVERTEMP:TEMP?

Example Response: 54.23

Which indicates that the over temperature disconnect is set to a temperature of 54.23.

Short Form: OVER:TEMP

CALCUR commands

The CALCUR commands are used to transfer sensor calibration curves between the controller and the host controller.

Curves are referenced by an index number. In the Model 32, there are four user curves numbered 1 through 4. In the Model 34 and 62, there are 12 user curves, numbered 1 through 12.

The CALCUR data block consists of a header, multiple curve entries and a terminator character.

The header consists of four lines as follows:

Sensor Name: Sensor name string, 15 characters max
Sensor Type: Enumeration, See [Sensor Types table](#)
Multiplier: Signed numeric
Units: Units of calibration curve: OHMS, VOLTS or LOGOHM

Each entry of a curve contains a sensor reading and the corresponding temperature. Sensor readings are in units specified by the units of the curve using the CALDATA:UNITS command. These units may be OHMS, VOLTS or LOGOHM. Temperature is always in Kelvin.

The format of an entry is:

<sensor reading> <Temperature>

Where <sensor reading> is a floating-point sensor reading and <Temperature> is a floating-point temperature in Kelvin.

Numbers are separated by one or more white spaces.

NOTE: Using the RS-232 interface, each line must be terminated by a New Line, a Carriage Return, a Line Feed or a Null character. This character is not used with the GPIB interface since the end of a line is signaled by the interface itself. Here, lines are transmitted to the controller by using sequential write commands.

Floating point numbers may be entered with many significant digits. They will be converted to 32 bit floating point. This supports about six significant digits.

The last entry of a table is indicated by a semicolon (;) character with no values in the numeric fields.

NOTE: All curves must have a minimum of two entries and a maximum of 200 entries.

Entries may be sent to the controller in any order. The unit will sort the curve in ascending order of sensor reading before it is copied to Flash RAM.

Entries containing invalid numeric fields will be deleted before they are stored.

The following is an example of a calibration curve transmitted to the controller via the GPIB interface:

```
CALCUR 1
Good Diode
Diode
-1.0
volts
0.34295 300.1205
0.32042 273.1512
0.35832 315.0000
1.20000 3.150231
1.05150 8.162345
0.53234 460.1436
;
```

The controller would sort the above table in ascending order of volts, then write it to FLASH memory as user curve #1. The curve name will be "Good Diode" and the native units are volts.

When a complete curve is received, it is conditioned, sorted and copied to FLASH memory. This process can take as long as 250 milliseconds with a long table.

 **Note:** When using the RS-232 interface, a time delay should of about 500mS should be inserted after sending the last line of a calibration table. This will allow the flash memory update to complete. Other remote interfaces do not require a delay.

 **Note:** Factory installed calibration curves may not be changed or deleted with these commands.

CALCUR: Calibration Curve Set or Query.

Sets or queries sensor calibration curve data.

Command Syntax:

```

CALCUR <index>
<sensor name>
<sensor type>
<multiplier>
<curve units>
<sensor reading 1> <Temperature 1>
<sensor reading 2> <Temperature 2>
•
<sensor reading N> <Temperature N>
;

```

 **Note:** A new line (\n) character must be appended to each line when using the RS-232 serial port. They should not be included when using the GPIB interface.

The maximum number of entries in a curve is 200 and the minimum is 2.

<index> is a numeric index to the user calibration curve list. Values are 1 through 4 in the Model 32 and 1 through 12 in the Model 34 and 62.

<curve name> is a name to be assigned to the calibration curve. It is a minimum of 4 and a maximum of 15 ASCII characters.

<sensor type> is from the following list: Diode, ACR, 31kR, 3.1kR, 312R, 625R, TC80, TC40 and None. If the sensor type cannot be identified, Diode is used.

Sensor Types are described in the section on [Supported Sensor Configurations](#) above.

<multiplier> is the temperature coefficient and curve multiplier. If this field cannot be identified, a value of -1.0 is assumed. This field is described in the section [Sensor Setup Menu](#) above.

<curve units> is the units of the curve. Choices are OHMS, VOLTS or LOGOHM.

The last entry in a calibration curve must be a single semicolon.

Query Syntax: CALCUR? <index>

Query Response: <calibration curve>

Short Form: CALC

PIDTABLE commands

The PIDTABLE commands are used to transfer PID tables between the Model 32 and the host controller.

PID Tables are referenced by their index number, which is between 0 and 5. Table data corresponding to a specific index may be identified using the PIDTABLE? query.

There is a maximum of 16 entries in each PID table. Each entry contains a setpoint, P, I and D coefficients and a heater range.

Either output channel may use any table.

The heater range field only applies to Loop #1. However, it must be specified in each entry.

The format of an entry is:

```
<setpoint> <P> <I> <D> <Heater Range>
```

Fields are separated by a white space. The entry is terminated by a new line (\n) character if the table is transmitted via the RS-232 interface and is not terminated for all others.

Floating point numbers may be entered with many significant digits. They will be converted to 32 bit floating point, which supports about six significant digits.

The heater range is an enumeration field that may have the following values:

Hi, Mid and Low

The file format of a PID table is shown below:

```
<name>  
<entry 0>  
<entry 1>  
*  
*  
*  
<entry N>  
;
```

Where:

<name> is the name of the table and is a maximum of 16 ASCII characters.

<entry> is a PID entry.

A line that contains only a single semicolon indicates the end of the table.

An example of a sixteen entry PID Table is as follows:

```
PID Test 0  
300.00 1.60 160.00 40.00 HI  
280.00 1.50 150.00 30.00 HI  
260.00 1.40 140.00 30.00 HI  
240.00 1.30 130.00 30.00 HI  
220.00 1.20 120.00 30.00 HI  
200.00 1.10 110.00 20.00 HI  
180.00 1.00 100.00 20.00 MID  
160.00 0.90 90.00 20.00 MID  
140.00 0.80 80.00 20.00 MID  
120.00 0.70 70.00 10.00 MID  
100.00 0.60 60.00 10.00 MID  
80.00 0.50 50.00 10.00 MID  
60.00 0.40 40.00 10.00 LOW  
40.00 0.30 30.00 0.00 LOW  
20.00 0.20 20.00 0.00 LOW  
10.00 0.10 10.00 0.00 LOW  
;
```

Entries may be sent to the Model 32 in any order. The unit will sort the table in ascending order of setpoint before it is copied to Flash RAM. Entries containing invalid numeric fields will be deleted.

PIDTABLE: PID Table Name Query.

Queries the name string of a PID table at a specified index.

Query Syntax: PIDTABLE? <index>

Query Response: <name>

Where <index> is the index to the PID table list and <name> is the name string associated with the specified table. Index may be from zero to five.

Query Example: PIDT? 2

Example Response: Joe's Cooler

Indicates that PID table #2 is named Joe's Cooler.

Short Form: PIDT?

PIDTABLE:NAME: PID Table Name.

Sets or queries the name string of the PID Table at a specified index.

The name string is used to associate a convenient name with a PID table. It may include up to 15 ASCII characters.

Command Syntax: PIDTABLE <index>:NAME <name>

Where <index> is a numeric index (0-3) to the PID table list and <name> is an ASCII name string in double quotes.

Query Syntax: PIDTABLE <index>:NAME?

Query Response: <name>

Where <index> is the index to the calibration curve list. <name> is the name string associated with the specified curve.

Command Example: PIDTABLE 1:NAME "Ed's table"

This command will assign the name of "Ed's table" to PID table located at index number 1.

Query Example: PIDTABLE 3:NAME?

Example Response: Mary's project

Indicates that the PID table at index 3 is named Mary's project.

Short Form: PIDT:NAM

PIDTABLE:NENTRY: Number of Entries.

Queries the number of entries in a PID Table. This number is generated from the table itself and cannot be changed using this command.

The maximum number of entries in a table is 16.

Query Syntax: PIDTABLE <index>:NENTRY?

Query Response: <number>

Where <index> is the index to the PID table list and <number> is the number of entries in the indexed table

Query Example: PIDTABLE 1:NENTRY?

Example Response: 5

Indicates that there are 5 entries in PID table 1.

Short Form: PIDT:NENT**PIDTABLE:TABLE: PID Table Set/Query.**

Sets or queries the entries in a PID table.

Command Syntax:

PIDTABLE <index>:TABLE

<name>

<setpoint> <P> <I> <D> <Heater Range>

<setpoint> <P> <I> <D> <Heater Range>

<setpoint> <P> <I> <D> <Heater Range>

•

•

•

<setpoint> <P> <I> <D> <Heater Range>

;

Where <index> is a numeric index of the PID table and <name> is the table name (15 characters maximum). Table entries are made according to the above description.

Fields within an entry are separated by one or more white space characters.

The last entry in a calibration curve must be a single semicolon.

Query Syntax: PIDTABLE <index>:TABLE

Query Response: <Table entries>

Where <Table entries> are the entries of the selected PID table.

CALDATA and SENTRY Commands

The CALDATA commands are used to add, delete or edit user-installed sensors. These commands are the remote equivalent of the front panel Sensor Setup menu.

SENTRY commands are used to query the name of a factory-installed sensor.

User-installed sensors are indexed from zero to 3. Factory installed sensors are indexed from zero to 60. For additional information, refer to [Appendix A](#).

CALDATA:NAME: Name for a user-installed sensor.

Sets or queries the name of a user-installed sensor.

Command Syntax: CALDATA <index>:NAME <val>

Where <index> is the index of the user-installed sensor and <val> the sensor's name string. The name string must be surrounded with double-quotation (") marks.

Query Syntax: CALDATA <index>:NAME?

Query Response: <name>

Where <index> is the index of the user-installed sensor and <name> is the name string for the indexed sensor.

Query Short Form: CALD? <index>

Where <index> is the index of the user-installed sensor and <val> the sensor's name string.

Query Example: CALDATA 3:NAME?

Example Response: "User Curve 2".

Short Form: CALD?

SENT:NAME: Name for a factory-installed sensor.

Queries the name of a factory-installed sensor.

Query Syntax: SENT <index>:NAME? Or SENT? <index>

Query Response: <name>

Where <index> is the index of the factory-installed sensor and <name> is the name string for the indexed sensor.

Query Example: SENT? 1

Example Response: "Cryocon S700".

Short Form: SENT?

CALDATA:TYPE: Sensor Type.

Sets or queries the sensor type at a Sensor Table index.

Supported sensor types are described above in the "[Supported Sensors](#)" section.

Command Syntax: CALDATA <index>:TYPE <stype>

Where <index> is the index to the user-installed sensor and <stype> the sensor type selected from the above list.

Query Syntax: CALDATA <index>:TYPE?

Query Response: <stype>

Where <index> is the index and <stype> is the sensor type.

Command Example: SENT 3:TYPE DIODE

This command assigns the Silicon Diode sensor type to the user-installed sensor at index 3.

Query Example: CALDATA 1:TYPE?

Example Response: TC80

This response indicates that the sensor at index 1 is a thermocouple.

Short Form: CALD:TYP

CALDATA:MULTIPLY: Calibration Curve Multiplier.

Sets or queries the Multiplier field for a user-installed sensor.

The multiplier field is a floating-point numeric entry and is used to specify the sensor's temperature coefficient and to scale the calibration curve. Negative multipliers imply that the sensor has a negative temperature coefficient. The absolute value of the multiplier scales the calibration curve. For example, the curve for a Platinum sensor that has 100 Ω of resistance at 0°C may be used with a 1000 Ω sensor by specifying a multiplier of 10.0.

Default is 1.0 for sensors with a positive temperature coefficient and -1.0 for a negative coefficient.

Command Syntax: CALDATA <index>:MULTIPLY <val>

Where <index> is the index to user installed sensor (0 through 3) and <val> the multiplier.

<index> is an integer and <val> is floating point with a range of ± 100.0 .

Command Example: CALD 1:MULT -10.1

This command sets the calibration table multiplier for user-installed sensor 1 to -10.1 and identifies it as having a negative temperature coefficient.

Query Syntax: CALDATA <index>:MULTIPLY?

Query Response: <val>

Where <index> is the index and <val> is the sensor type multiplier.

Query Example: CALD 2:MULT?

Example Response: 1.000000

This response indicates that the sensor at index 2 has a positive temperature coefficient and a calibration curve multiplier of 1.0.

Short Form: CALD:MULT

AUTOTUNE commands

Autotuning via the remote interface requires the following sequence:

1. The Model 32 must be controlling temperature and the loop must be stable in terms of both temperature and output power.
2. Values for Delta Power and Timeout should be set.
3. The Autotune process model is initiated by the command AUTOTUNE:START.
4. Status can be monitored using the AUTOTUNE:STATUS command.
5. When a status of complete is indicated, the generated values for P,I and D may be read.
6. Execution of the AUTOTUNE:SAVE command will transfer the generated PID coefficients to the actual loop coefficients and continue controlling the process in PID mode.
7. Execution of the AUTOTUNE:EXIT command at any time will abort the autotune process and discard any generated PID values.

Refer to the section on [autotuning](#) for information about this process.

AUTOTUNE:DELTA: Maximum Delta in Power.

Sets and queries the maximum allowed change in heater output power that is allowed during the process modeling phase of the autotuning process.

This a numeric field that is expressed as a percent of full scale heater output power. The actual power output depends on the range setting of the heater. If a value of 100% is used, the controller may use any output power within the current range.

Command Syntax: <oc>:AUTOTUNE:DELTA <value>

Where <oc> is the output channel to tune and may be either LOOP 1 or LOOP 2. <value> is the maximum allowed change in output power expressed as a percent of full scale.

Query Syntax: <oc>:AUTOTUNE:DELTA?

Query Response: <value>

Where <oc> is the output channel to tune and may be either LOOP 1 or LOOP 2. <value> is the current Delta Power setting.

Command Example: LOOP 1:AUTOTUNE:DELTA 100

This sets the maximum change in output power to 100% of full scale. This will allow the tuning process to use any output level.

Query Example: LOOP 2:AUTOTUNE:DELTA?

Example Response: 25.0000

This response says that the maximum change in output power used by autotune will be $\pm 25\%$ of the current output power level.

Short Form: AUT:DELTA

AUTOTUNE:TIMEOUT: Autotune Timeout.

Sets and queries the timeout value of the autotune process. This is a numeric field that specifies the maximum time, in seconds, that the autotune process model will wait for it's internal error vector to converge without declaring a timeout condition.

Command Syntax: <oc>:AUTOTUNE: TIMEOUT <value>

Where <oc> is the output channel to tune and may be either LOOP 1or LOOP 2. <value> is the timeout period in seconds.

Query Syntax: <oc>:AUTOTUNE: TIMEOUT?

Query Response: <value>

Where <oc> is the output channel to tune and may be either LOOP 2or LOOP 2. <value> is the timeout period in seconds.

Command Example: LOOP 2:AUTOTUNE: TIMEOUT 200

Sets the autotune timeout period to 200 Seconds.

Query Example: LOOP 1:AUTOTUNE:TIME?

Example Response: 250.000

Identifies the autotune timeout period as 250 seconds.

Short Form: AUT:TIM

AUTOTUNE:START: Initiate Autotune.

Initiates the autotune sequence.

Command Syntax: <oc>:AUTOTUNE:START

Where <oc> is the output channel to tune and may be either LOOP 1or LOOP 2.

Command Example: LOOP 1:AUTOTUNE: START

Initiates autotuning the heater.

Short Form: AUT:STAR

AUTOTUNE:EXIT: Abort Autotune.

Aborts and exits the autotune process.

Command Syntax: <oc>:AUTOTUNE: EXIT

Where <oc> is the output channel to tune and may be either LOOP 1 or LOOP 2.

Command Example: LOOP 2:AUTOTUNE: EXIT

Aborts autotuning.

Short Form: AUT:EXIT

AUTOTUNE:SAVE: Save PID Coefficients.

When an autotune sequence has successfully completed, this command will save the generated PID values to the control loop PID values and change the autotune state from 'complete' to 'idle'.

Command Syntax: <oc>:AUTOTUNE:SAVE

Where <oc> is the output channel to tune and may be either LOOP 1 or LOOP 2.

Command Example: LOOP 2:AUTO:SAVE

Short Form: AUT:SAVE

AUTOTUNE:PGAIN: Proportional Gain.

When an autotune sequence has successfully completed, the AUTOTUNE:PGAIN command can be used to query the generated P, or P gain, term.

Query Syntax: <oc>:AUTOTUNE:PGAIN?

Query Response: <value>

Where <oc> is the output channel to tune and may be either LOOP 1 or LOOP 2. <value> is the generated P gain feedback coefficient.

Query Example: LOOP 2:AUTO:PGA?

Example Response: 125.0000

Indicates that the generated P gain term is 125.

Short Form: AUT:PGA

AUTOTUNE:IGAIN: Integral Gain

When an autotune sequence has successfully completed, the AUTOTUNE:IGAIN command can be used to query the generated I, or integrator gain, term.

Query Syntax: <oc>:AUTOTUNE:IGAIN?

Query Response: <value>

Where <oc> is the output channel to tune and may be either LOOP 1 or LOOP 2. <value> is the generated I feedback term in Seconds.

Query Example: LOOP 1:AUTO:IGA?

Example Response: 225.0000

Indicates that the generated I gain term is 225. Seconds.

Short Form: AUT:IGA

AUTOTUNE: DGAIN: Derivative Gain.

When an autotune sequence has successfully completed, the AUTOTUNE:DGAIN command can be used to query the generated D, or differentiator gain, term.

Query Syntax: <oc>:AUTOTUNE:GAIN?

Query Response: <value>

Where <oc> is the output channel to tune and may be either LOOP 1 or LOOP 2. <value> is the generated D feedback term in inverse Seconds.

Query Example: LOOP 2:AUTO:DGA?

Example Response: 22.0000

Indicates that the generated D gain term is 22 / Seconds.

Short Form: AUT:DGA

AUTOTUNE:STATUS: Autotune Status.

Queries the status of the autotune process. Return values are:

Idle	- Autotune has not started.
Running	-Autotune is running.
Complete	-Autotune successfully completed.
Failed	-Unable to generate PID values.
Abort	-Aborted by operator intervention.

Query Syntax: <oc>:AUTOTUNE:STATUS?

Query Response: <status>

Where <oc> is the output channel to tune and may be either LOOP 1 or LOOP

2. <status> is the current status of the autotune process from the above list

Query Example: LOOP 1:AUTO:STATUS?

Example Response: COMPLETE

Indicates that autotune has successfully completed and generated values for PID are available.

Short Form: AUT:STAT?

INSTCAL commands

The INSTCAL commands are used to calibrate the Model 32 input sensor measurement circuitry. They should only be used in association with the instrument's calibration procedure.

Instrument calibration requires the use of various transfer standard resistance and voltage references.

In order to calibrate the Model 32, the calibration mode must first be turned on by using the INST:MODE ON command. Issuing this command will cause the unit to copy the actual calibration data from flash memory to temporary RAM. Further, the unit will display raw voltage data that has had the RAM calibration coefficients applied.

The temporary RAM calibration data is manipulated using the OFFSET and GAIN and TYPE commands for each input channel. RAM is copied back to the actual FLASH memory calibration data table using the SAVE command.

The Model 32 is returned to normal operation by using the INSTCAL:MODE OFF command. Note that this does not write data to the calibration FLASH memory area.

INSTCAL:MODE

Queries or sets the instrument calibration mode. Calibration mode must be turned on before most instrument calibration commands are effective.

Command Syntax: INSTCAL <chan>:MODE <mode>

Where <chan> is the input channel number (required but not used) and <mode> is the desired mode, which may be either ON or OFF.

Command Example: INST A:MODE ON

Places the Model 32 in calibration mode.

Query Syntax: INSTCAL <chan>:MODE?

Where <chan> is the input channel number (required but not used).

Query Response: <mode>

Where <mode> is the calibration mode indicator and will be either ON or OFF.

Query Example: INSTCAL <chan>:MODE?

Example Response: OFF

Indicates that the Model 32 is not in calibration mode

Short Form: INST <chan>:MOD

INSTCAL:SAVE

This command copies the temporary RAM calibration data table to the actual FLASH memory instrument calibration area. It can only be used when the instrument is in calibration mode; Otherwise, it does nothing.

Command Syntax: INSTCAL <chan>:SAVE

Where <chan> is the input channel number (required but not used) Note that, even though a channel indicator is specified, the entire RAM table for all four input channels is copied to FLASH memory. Therefore, this command should only be issued once when the entire procedure is complete.

Command Example: INST A:SAVE**Short Form:** INST <chan>:SAVE

INSTCAL:TYPE

Sets or queries the type of calibration that is being applied to a specified input channel. This command is only effective when the unit is in calibration mode.

Calibration types are shown below:

V10UA - Voltage calibration. Full scale is 2.5V

I10UA - 10UA constant-current source calibration.

R1MA - Resistance calibration. Full scale is 2500Ω.

R100UA - Resistance calibration. Full scale is 25KΩ.

R10UA - Resistance calibration. Full scale is 250KΩ.

Command Syntax: INSTCAL <chan>:TYPE <type>

Where <chan> is the input channel indicator and <type> is the desired calibration type from the above list.

Command Example: INST A:TYPE R10UA

Places the calibration type to R10UA.

Query Syntax: INSTCAL <chan>:TYPE?

Where <chan> is the input channel indicator.

Query Response: <type>

Where <type> is the calibration type from the above list.

Query Example: INSTCAL <chan>:TYPE?

Example Response: V10UA

Indicates that the calibration type is V10UA

Short Form: INST <chan>:TYP

INSTCAL:GAIN

Sets or queries gain calibration factor that is applied to the specified input channel.

GAIN is a floating point number with a nominal value of 1.000.

There is a GAIN factor for each calibration type within a channel. Therefore, before the INST:GAIN is used, the INST:TYPE command should be used to set the calibration type.

Command Syntax: INSTCAL <chan>:GAIN <gain>

Where <chan> is the input channel indicator and <gain> is the desired gain calibration factor.

Command Example: INST A:GAIN 0.999423

Sets the gain calibration factor for input channel A to 0.999423.

Query Syntax: INSTCAL <chan>:GAIN?

Where <chan> is the input channel indicator.

Query Response: <gain>

Where <gain> is the gain calibration factor.

Query Example: INSTCAL B:GAIN?

Example Response: 0.994321

Indicates that the gain calibration factor for input channel B is 0.994321

Short Form: INST <chan>:GAIN

INSTCAL:OFFSET

Sets or queries offset calibration factor that is applied to the specified input channel.

OFFSET is an integer that is in ADC counts and may be either positive or negative.

There is an OFFSET factor for each calibration type within a channel. Therefore, before the INST:OFFSET is used, the INST:TYPE command should be used to set the calibration type.

Command Syntax: INSTCAL <chan>: OFFSET <offset>

Where <chan> is the input channel indicator and <offset> is the desired offset calibration factor.

Command Example: INST B: OFFSET -321

Sets the offset calibration factor for input channel B to -321.

Query Syntax: INSTCAL <chan>: OFFSET?

Where <chan> is the input channel indicator.

Query Response: <offset>

Where <offset> is the offset calibration factor.

Query Example: INSTCAL B: OFFSET?

Example Response: 23

Indicates that the offset calibration factor for input channel B is 23

Short Form: INST <chan>:OFFS

Remote Command Summary

Command	Function
IEEE Common Commands	
*ESE, *ESE?	The *ESE command sets and queries the Standard Event Status Enable (ESE) Register bits.
*ESR?	Returns the Standard Event (SEV) register.
*IDN?	Returns Instrument Identification String.
*OPC?	Set the operation complete bit in the Standard Event (SEV) status register when all pending device operations have finished.
*RST	Reset the controller.
Control Loop Start/Stop commands	
STOP	Disengage all control loops.
CONTROL CONTROL?	Engage all control Loops. Query if the loops are engaged.
SYSTEM commands	
SYSTEM:LOCKOUT SYSTEM:LOCKOUT?	Sets or queries the remote lockout status indicator.
SYSTEM:BEEP	Asserts the audible alarm.
SYSTEM:REMLED SYSTEM:REMLED	Sets or queries the remote LED status indicator on the front panel.
SYSTEM:LOOP?	Reports the status of the two temperature control loops.
SYSTEM:DISTC SYSTEM:DISTC?	Set or query the display filter time constant. Available time constants are 0.5, 1, 2, 4, 8, 16, 32 or 64 Seconds.
SYSTEM:ADRS SYSTEM:ADRS?	Set or query the address that the IEEE-488.2 interface will use.
SYSTEM:RESEED	Reseeds the display filter for all of the input channels, resulting in faster settling.
SYSTEM:SYNCTAPS	Sets the number of taps used by the synchronous filter.
SYSTEM:REMOTE	Sets the remote interface port. Choices are GPIB and RS232.

Command	Function
SYSTEM:AMBIENT?	Query the temperature of the controller's internal voltage reference. Example Output: +25C
SYSTEM:AUTOCAL	Perform an autocalibrate sequence on both input channels. Generally used only to correct for errors caused by significant changes in operating temperature.
SYSTEM:HTRHST?	Query the temperature of the internal LOOP #1 heatsink. Example output: +62C
SYSTEM:HOME	Causes the display on the front panel to go to the Operate Screen.
SYSTEM:NAME SYSTEM:NAME?	Set or query the instrument's name string. Example: SYSTEM:NAME "Cryocooler Four"
SYSTEM:DRES SYSTEM:DRES?	Sets or queries the controller's display resolution. Choices are: Full, 1, 2 or 3.
SYSTEM:HWREV?	Queries the instrument's hardware revision level.
SYSTEM:FWREV?	Queries the instrument's firmware revision level.
SYSTEM:ERROR?	Queries the instrument's error queue.
SYSTEM:CJTEMP?	Queries the internal Cold Junction Compensation temperature for thermocouple sensors.
SYSTEM:PUCONTROL SYSTEM:PUCONTROL?	Sets or queries the power-up-in-control mode setting.
SYSTEM:LINEFREQ SYSTEM:LINEFREQ?	Sets or queries the AC Power Line frequency setting.
SYSTEM:SETUP:RESTORE	Saves the current instrument setup to a user setup.
SYSTEM:NVSAVE	Save the instrument configuration to flash memory so that it will be restored on the next power-up.
SYSTEM:CONTRAST SYSTEM:CONTRAST?	Set or query the contrast of the front panel VFD display. (Model 34, 62 Only)

Command	Function
CONFIG commands	
CONFIG:NAME	Sets or queries the name of a user setup
CONFIG:SAVE	Saves the current instrument setup to a user setup.
CONFIG:RESTORE	Restores a previously saved instrument configuration.

Command	Function
Input Channel Commands	
INPUT? INPUT:TEMPER?	Query the current temperature reading on any of the input channels.
INPUT:UNITS INPUT:UNITS	Sets or reports the display units of temperature used by the specified input channel.
INPUT:ISENIX INPUT:ISENIX	Sets or queries the sensor index number assigned to an input channel. Applies to factory installed sensors. Refer to Appendix A .
INPUT:USENIX INPUT:USENIX	Sets or queries the sensor index number assigned to an input channel. Applies to user installed sensors. Refer to Appendix A .
INPUT:SENIX INPUT:SENIX	(Obsolete. Use USENIX or ISENIX commands described above) Sets or queries the sensor index number assigned to an input channel.
INPUT:VBIAS INPUT:VBIAS?	Set or query the sensor voltage excitation used in the constant-voltage mode. Applies to constant-voltage mode sensors only.
INPUT:NAME INPUT:NAME?	Sets or queries the name string of the specified input channel.
INPUT:ALARM?	Queries the alarm status of the specified input channel.
INPUT:ALARM:HIGHEST INPUT:ALARM:HIGHEST?	Sets or queries the temperature setting of the high temperature alarm for the specified input channel.
INPUT:ALARM:LOWEST INPUT:ALARM:LOWEST?	Sets or queries the temperature setting of the low temperature alarm for the specified input channel.
INPUT:ALARM:HIENA INPUT:ALARM:HIENA?	Sets or queries the high temperature alarm enable for the specified input channel.
INPUT:ALARM:LOENA INPUT:ALARM:LOENA?	Sets or queries the low temperature alarm enable for the specified input channel.
INPUT:ALARM:FAULT INPUT:ALARM:FAULT?	Sets or queries the sensor fault alarm enable for the specified input channel.
INPUT:ALARM:AUDIO INPUT:ALARM:AUDIO?	Set or query the audible alarm enable for the selected input channel.

Command	Function
Input Channel Commands	
INPUT:SENPR?	Queries an input channel reading in basic sensor units. Sensor units are Volts for diode and thermocouple sensors and Ohms for resistor sensors.
Input Channel Statistics	
INPUT:MINIMUM?	Queries the minimum temperature that has occurred on an input channel since the STATS:RESET command was issued.
INPUT:MAXIMUM?	Queries the Maximum temperature that has occurred on an input channel since the STATS:RESET command was issued.
INPUT:VARIANCE?	Queries the temperature variance that has occurred on an input channel since the STATS:RESET command was issued.
INPUT:SLOPE?	Queries the input channel statistics. SLOPE is the slope of the best fit straight line passing through all temperature samples that have been collected since the STATS:RESET command was issued.
INPUT:OFFSET?	Queries the input channel statistics. OFFSET is the offset of the best fit straight line passing through all temperature samples that have been collected since the STATS:RESET command was issued.
STATS:TIME?	Queries the time duration over which input channel statistics have been accumulated.
STATS:RESET	Resets the accumulation of input channel statistical data.

Command	Function
LOOP Commands	
LOOP:SOURCE LOOP:SOURCE?	Sets and queries the selected control loop's controlling input channel.
LOOP:SETPT LOOP:SETPT?	Sets and queries the selected control loop's setpoint.
LOOP:TYPE LOOP:TYPE?	Sets and queries the selected control loop's control type.
LOOP 1:RANGE LOOP 1:RANGE?	Sets or queries the control loop #1, or the primary heater, output range.
LOOP:TABLEIX LOOP:TABLEIX?	Sets or queries the table number that is used with control modes that use PID tables.
LOOP:RAMP?	Queries the unit to determine if a temperature ramp is in progress on the specified control loop.
LOOP:RATE LOOP:RATE?	Sets and queries the ramp rate used by the selected control loop when performing a temperature ramp.
LOOP:NAME LOOP:NAME?	Sets or queries the name string for the selected control loop
LOOP:PGAIN LOOP:PGAIN?	Sets or queries the selected control loop's proportional gain term.
LOOP:IGAIN LOOP:IGAIN	Sets and queries the integrator feedback term used by the selected control loop.
LOOP:DGAIN LOOP:DGAIN	Sets and queries the differentiator feedback term used by the selected control loop.
LOOP:HTRREAD?	Queries the output current of the selected control loop.
LOOP:MAXPWR LOOP:MAXPWR?	Sets and queries the maximum allowed output power.
LOOP:MAXSET LOOP:MAXSET?	Sets and queries the maximum setpoint.
LOOP 1:LOAD LOOP 1:LOAD?	Sets or queries the load resistance setting of the primary heater (Loop 1).
LOOP:PMANUAL LOOP:PMANUAL?	Sets and queries the output power level used by the selected control loop feedback when it is in Manual control mode.

Command	Function
Over Temperature Disconnect Commands	
OVERTEMP:ENABLE OVERTEMP:ENABLE?	Sets and queries the over temperature disconnect enable.
OVERTEMP:SOURCE OVERTEMP:SOURCE?	Sets and queries the input channel that is used as the source for the Over Temperature Disconnect feature.
OVERTEMP:TEMP OVERTEMP:TEMP?	Sets and queries the temperature used by the over temperature disconnect feature.
Sensor Calibration Curve Commands	
CALCUR CALCUR?	Sets or queries sensor calibration curve data.
PID Table Commands	
PIDTABLE PIDTABLE?	Queries the name string of a PID table at a specified index.
PIDTABLE:NENTRY PIDTABLE:NENTRY?	Queries the number of entries in a PID Table.
PIDTABLE:TABLE PIDTABLE:TABLE?	Sets or queries the entries in a PID table.

Command	Function
Relay Commands (Model 34 and 62 only)	
RELAYS?	Relay Status Query.
RELAYS: SOURCE RELAYS: SOURCE?	Sets or queries the source input channel for a specified relay.
RELAYS: HIGHEST RELAYS: HIGHEST?	Sets or queries the temperature setting of the high temperature setpoint for the specified relay.
RELAYS:LOWEST RELAYS:LOWEST?	Sets or queries the temperature setting of the low temperature setpoint for a specified relay.
RELAYS: HIENA RELAYS: HIENA?	Sets or queries the high temperature enable for the specified relay.
RELAYS:LOENA RELAYS:LOENA	Sets or queries the low temperature enable for the specified relay.
RELAYS:FAULT RELAYS:FAULT	Sets or queries the sensor fault enable for the specified relay.
Sensor Setup Commands	
CALDATA? CALDATA:NAME CALDATA:NAME?	Sets or queries the name string for a user-installed sensor.
CALDATA:TYPE CALDATA:TYPE?	Sets or queries the sensor type for a user-installed sensor.
CALDATA:MULTIPLY CALDATA:MULTIPLY?	Sets or queries the Multiplier for a user-installed sensor.
SENTYPE? SENTYPE:NAME SENTYPE:NAME?	Queries the name string for a factory-installed sensor. Please refer to Appendix A .

Command	Function
Autotune Commands	
AUTOTUNE:DELTAP AUTOTUNE:DELTAP?	Sets and queries the maximum allowed change in heater output power that is allowed during the process modeling phase of the autotuning process.
AUTOTUNE:TIMEOUT AUTOTUNE:TIMEOUT?	Sets and queries the timeout value of the autotune process.
AUTOTUNE:START	Initiates the autotune sequence.
AUTOTUNE:EXIT	Aborts and exits the autotune process.
AUTOTUNE:SAVE	When an autotune sequence has successfully completed, this command will save the generated PID values to the control loop PID values and change the autotune state from 'complete' to 'idle'.
AUTOTUNE:PGAIN?	Query the generated P gain term generated by autotune.
AUTOTUNE:IGAIN?	Query the generated I gain term generated by autotune.
AUTOTUNE:DGAIN?	Query the generated D gain term generated by autotune.
AUTOTUNE:STATUS?	Queries the status of the autotune process.
Cryocooler Filter Commands	
CCFILTER: STATUS?	Query Cryocooler filter status.
CCFILTER: TYPE CCFILTER: TYPE?	Set or query filter type. Types are: OFF, Input or Cancel.
CCFILTER: STEP CCFILTER: STEP?	Set or query the filter adaptation step size.
CCFILTER: LOOP CCFILTER: LOOP?	Set or query the control loop number controlled by the cryocooler filter.
CCFILTER: NTAPS CCFILTER: NTAPS?	Set or query the number of taps in the filter.
CCFILTER:RESET	Reset the Cryocooler filter.

Table 37: Remote Command Summary

EU Declaration of Conformity
According to ISO/IEC Guide 22 and EN 45014

Product Category: Measurement, Control and Laboratory
Product Type: Temperature Measuring and Control System
Model Numbers: Model 32
Manufacturer's Name: Cryogenic Control Systems, Inc.
Manufacturer's Address:

P. O. Box 7012
Rancho Santa Fe, CA 92067
Tel: (858) 756- 3900, Fax: 858. 759. 3515

The before mentioned products comply with the following EU directives:

89/336/EEC, "Council Directive of 3 May 1989 on the approximation of the laws of the Member States relating to electromagnetic compatibility"

73/23/EEC, "Council Directive of 19 February 1973 on the harmonization of the laws of Member States relating to electrical equipment designed for use within certain voltage limits".

The compliance of the above mentioned product with the Directives and with the following essential requirements is hereby confirmed:

<u>Emissions</u>	<u>Immunity</u>	<u>Safety</u>
EN 55011, 1998	EN 50082-1, 1997	EN 61010-1, 2001 IEC 61010-1, 2001

The technical files and other documentation are on file with Mr. Guy Covert, President and CEO.

As the manufacturer we declare under our sole responsibility that the above mentioned products comply with the above named directives.



Guy D. Covert
President, Cryogenic Control Systems, Inc.
October 15, 2005

Appendix A: Installed Curves

Factory Installed Curves

The following is a list of factory-installed sensors and the corresponding sensor index (ISENIX).

isenix	Name	Description
0	None	Input disabled
1	Cryocon S700	Cryo-con S700 series Silicon Diode. Range: 1.4 to 380K. 10 μ A constant current excitation.
2	LS DT-670	Lakeshore Silicon Diode Curve 11 for DT-670 series diodes. Range: 1.4 to 500K. 10 μ A constant current excitation.
3	LS DT-470	Lakeshore Silicon Diode Curve 10 for DT470 series diodes. Range: 1.4 to 495K. 10 μ A constant current excitation.
4	CD-12A Diode	Cryo Industries CD-12A Silicon Diode. Range: 1.4 to 325K. 10 μ A constant current excitation.
5	SI 410 Diode	Scientific Instruments, Inc. 410 Diode Curve. Range: 1.5 to 450K. 10 μ A excitation.
6	Cryocon S800	Cryo-con S800 series Silicon Diode. Range: 1.4 to 380K. 10 μ A constant current excitation.
7	Cryocon S900	Cryo-con S900 series Silicon Diode. Range: 1.5 to 500K. 10 μ A constant current excitation.
8	CTI Diode	CTI Cryopump diode. 10K to 325K
20	Pt100 385	DIN43760 standard 100 Ω Platinum RTD. Range: 23 to 1023K, 1mA excitation.
21	Pt1K 385	1000 Ω at 0 $^{\circ}$ C Platinum RTD using DIN43760 standard calibration curve. Range: 23 to 1023K, 100 μ A excitation.
22	Pt10K 385	10K Ω at 0 $^{\circ}$ C Platinum RTD. Temperature coefficient 0.00385, Range: 23 to 475K, 10 μ A excitation.
23	RhFe 27, 1mA	Rhodium-Iron resistor, 27 Ohms at 0 $^{\circ}$ C. 1mA DC excitation.
31	RO-600 AC	Scientific Instruments Inc. RO-600 Ruthenium Oxide sensor with constant-voltage AC excitation.
32	RO-105 DC 10 μ A	Scientific Instruments Inc. RO-105 Ruthenium Oxide sensor with constant-current 10 μ A DC excitation
33	R500	Cryocon R500 Ruthenium Oxide sensor with constant-voltage AC excitation.
34	R400	Cryocon R400 Ruthenium Oxide sensor with constant-current 10 μ A DC excitation
45 46 47 48	TC type K TC type E TC type T AuFe 0.07%	Only available when thermocouple option is installed thermocouples type K, E and T, Direct input to the controller. Range: Type T: 3.5 to 673K, Type E: 3.5 to 1273K, Type K: 3.5 to 1643K.

Table 38: Factory Installed Sensors

Note that Thermocouple devices only appear on units ordered with the thermocouple option.

The isenix remote command is used to set factory installed sensors. For example, the command:

INPUT B ISENIX 33 would set input B to use the RO-600 sensor.

INPUT A:ISENIX 1 would set input A to use the S700 Diode.

INPUT A:ISENIX 0 would turn input A off by setting the sensor to 'none'.

User Installed Sensor Curves

The user may install up to four custom sensors. This table shows the sensor index and default name of the user curves:

usenix index	User Number	Default Name
0	0	User Sensor 0
1	1	User Sensor 1
2	2	User Sensor 2
3	3	User Sensor 3

When using the CALCUR commands, only user curves are addressed, therefore, the user index (usenix) shown above is used.

The USENIX, remote commands address user installed curves. For example:

CALCUR 2 would address user curve #2.

INPUT A:USENIX 1 would set input A to use User Sensor 1.

Sensor Curves on CD

The following sensors are available on the CD supplied:

File	Description
CryocalD3.crv	Cryocal D3 Silicon Diode. Range: 1.5 to 300K
CTIdiode.crv	CTI cryo-pump silicon diode. Range: 10K to 325K
SI410.crv	Scientific Instruments, Inc. SI-410 Silicon Diode. Range: 1.5 to 450K
Curve10.crv	Lakeshore Curve 10 Silicon Diode curve for DT-470 series diodes. Range: 1.4 to 495K.
Curve11.crv	Lakeshore Curve 10 Silicon Diode curve for DT-670 series diodes. Range: 1.4 to 500K.
PT100385.crv	Cryocon CP-100, DIN43760 or IEC751 standard Platinum RTD, 100 Ω at 0°C. Range: 23 to 1023K
PT1K385.crv	DIN43760 or IEC751 standard Platinum RTD, 1000 Ω at 0°C. Range: 23 to 1023K
PT1003902.crv	Platinum RTD, 100 Ω at 0°C Temperature coefficient 0.003902 Ω /C. Range: 73K to 833K.
PT1K375.crv	Platinum RTD, 1000 Ω at 0°C Temperature coefficient 0.00375 Ω /C. Range: 73K to 833K.
aufe07cr.crv	Chromel-AuFe 7% Thermocouple. Range: 3 to 610K
TCTypeE.crv	Thermocouple, Type E. Range: 3.2 to 1273K
TCTypeK.crv	Thermocouple, Type K. Range: 3.2 to 1643K
TCTypeT.crv	Thermocouple, Type T. Range: 3.2 to 673K
CX1030E1.crv	Cernox™ CX1030 example curve. Range: 4 to 325K

Appendix B: Troubleshooting Guide

Error Displays

Display	Condition
<div style="border: 1px solid black; padding: 5px; display: inline-block;"> A - - - - - K </div> <p>erratic display of temperature.</p>	<p>Or, an</p> <p>Input channel voltage measurement is out of range. Ensure that the sensor is connected and properly wired. Ensure that the polarity of the sensor connections is correct. Refer to the Sensor Connections section.</p> <p>Many sensors can be checked with a standard Ohmmeter. For resistor sensors, ensure that the resistance is correct by measuring across both the Sense and Excitation contacts. For a diode sensor, measure the forward and reverse resistance to ensure a diode-type function.</p>
<div style="border: 1px solid black; padding: 5px; display: inline-block;"> A K </div>	<p>Input channel is within range, but measurement is outside the limits of the selected sensor's calibration curve. Check sensor connections as described above. Ensure that the proper sensor has been selected. Refer to the Input Channel Setup Menus section.</p> <p>Change the sensor units to Volts or Ohms and ensure that the resulting measurement is within the selected calibration curve. Refer to the section on Sensor Setup to display the calibration curve.</p>

Display	Condition
<div style="border: 1px solid black; padding: 5px; display: inline-block;"> Reading Record: 0000 Errors: 00 </div>	<p>The controller's firmware has been corrupted (Invalid Checksum). Re-load the unit's firmware. Refer to the section Downloading Instrument Firmware.</p>
<div style="border: 1px solid black; padding: 5px; display: inline-block;"> ADC Failure! </div>	<p>The input temperature measurement circuitry has failed. Contact Cryo-con technical support.</p>
<div style="border: 1px solid black; padding: 5px; display: inline-block;"> Memory Error! </div>	<p>The self-test procedure detected an error in the controller's RAM memory. Contact Cryo-con Support.</p>

Control Loop and Heater Problems

Symptom	Condition
Overtemp displayed.	<p>The control loops were disengaged by detection of an excessive internal temperature. Possible causes:</p> <ul style="list-style-type: none"> Shorted heater. Check heater resistance. Selection of a heater resistance that is much greater than the actual heater resistance. Refer to the Control Loop Setup menu section. Selection of an AC Power line voltage that is much less than the actual voltage. Refer to the Fuse Replacement and Voltage Selection section. Check that the instrument's fan is running and that the sides and rear panel allow easy air flow.
Readback displayed.	The control loops were disengaged by the heater current read-back monitor. Most likely cause is an open heater.
SensorFLT displayed.	The control loops were disengaged by a sensor fault condition. Correct the input sensor fault condition to proceed. The control loops will only engage when there is a valid temperature reading on their input. The exception is when a loop is assigned a control mode of Off or Manual.
OTDisconn displayed.	The control loops were disengaged by the Over Temperature Disconnect monitor. This was done to protect user equipment from damage due to overheating. To configure the monitor, refer to the System Functions Menu section.
The heater output current monitor is jumping up and down by about 1%	This is normal and does not indicate unstable heater power. The output current monitor is coarsely quantized and is displayed only for an indication of proper function.
The controller should be applying power, but the display is showing 0% output.	The output indicated on the display is the actual measured output power of the control loop. A reading of 0% while the controller is attempting to output power usually indicates an open heater.

Symptom	Condition
Unstable control.	<p>If the system is oscillating, try de-tuning the PID values by decreasing P, increasing I and setting D to zero. If the oscillations cannot be stopped by this procedure, the cause is likely that your system has an excessive time delay. Linear control algorithms, including PID, cannot control systems with excessive time delay. These problems often occur in systems that use heat pipes, or depend on gas flow between the heater and temperature sensor elements. The only solution to such systems is to re-design the equipment to reduce the time delay, or to externally implement a time delay compensation algorithm, such as a Smith Predictor.</p> <p>Do not try to control on Ohms or Volts. The controller will work correctly with either of these sensor units, but the PID values required are significantly different and most sensors are non-linear. Furtherer, there is no advantage to controlling in sensor units.</p> <p>Optimize the control loop parameters by using the Autotune feature described in the Autotuning section.</p> <p>Most cryogenic systems require significantly different PID parameters at different temperatures. To ensure stable control over a wide temperature range, use the PID Table feature described in the PID Table Entry section.</p> <p>If the heater is controlling with an output power level less than 10%, switch to the next lower heater range.</p>

Symptom	Condition
Autotune indicates a status of 'Abort' or 'Fail'.	<p>Autotune will only abort if the control loops are not engaged or there is an invalid temperature reading on the control input channel. If it cannot generate a solution because of issues in the system dynamics, it will indicate a status of 'Fail'.</p>
Autotune times out and does not generate effective PID parameters.	<p>Extend the Display Filter time constant to reduce system level noise and try autotune again. The display filter is described in the System Functions Menu section. Systems using Diode type sensors above 50K will usually require a 4 or 8 second time constant. This setting may be returned to any desired value once tuning is complete.</p> <p>Switch to the lowest possible heater range that will control at the target setpoint.</p> <p>Try autotuning in the PI- mode instead of PID. Most cryogenic systems do not benefit from the D term.</p> <p>If a Cryo-cooler is being used, set the controller's cryocooler filter to Input mode. This may be returned to Off or Cancel mode once tuning is complete.</p> <p>Experiment with the DeltaP parameter. Increasing it often improves autotune success.</p>

Temperature Measurement Errors

Symptom	Condition
Noise on temperature measurements.	<p>Possible causes:</p> <p>Excessive noise pickup, especially AC power line noise. Check your wiring and shielding. Sensors must be floating, so check that there is no continuity between the sensor connection and ground. Review the System Shielding and Grounding Issues section.</p> <p>Note: Cryo-con controllers use a shielding scheme that is slightly different than some other controllers. If you are using cable sets made for use with other controllers, some shield connections may need to change. If pin 3 of the input connector is connected to the cable shield, disconnect it and either re-connect the shield to the backshell contact or leave the shield floating. No connection should ever be made to pin 3 of the input connector.</p> <p>Check for shielding problems by temporarily removing the input connector's backshell. If the noise changes significantly, current is being carried by the shields and is being coupled into the controller.</p> <p>Use a longer display filter time constant to reduce displayed noise.</p>

Symptom	Condition
DC offset in temperature measurements.	<p>Possible causes:</p> <p>The wrong sensor type or sensor calibration curve is being used. Refer to the Input Channel Setup Menu section.</p> <p>DC offset in cryostat wiring. Review the Thermal EMF and AC Bias Issues section. Use AC bias, if necessary, to cancel the offset error.</p> <p>A four-wire measurement is not being used. Some cryostats use a two-wire measurement internally. This can cause offset errors due to lead resistance.</p> <p>Thermocouples: These sensors will often have DC offset errors. Use the CalGen™ feature to generate a new sensor calibration curve that corrects for these errors.</p>
No temperature reading.	Review the Error Displays section above.

Remote I/O problems

Symptom	Condition
Can't talk to RS-232 interface.	<p>Possible causes:</p> <p>Ensure that the RS-232 port is selected. Press the Sys key and scroll down to the RIO-Port: field.</p> <p>Ensure that the baud rate of the controller matches that of the host computer. To check the controller's baud rate, press the Sys key and scroll down to the RIO-RS232 field.</p> <p>Ensure that the host computer settings are 8-bits, No parity, one stop bit.</p> <p>The RS-232 port does not have an effective hardware handshake method. Therefore, terminator characters must be used on all strings sent to the controller. Review the RS-232 Configuration section.</p> <p>Ensure that you are using a Null-Modem type cable. There are many variations of RS-232 cables and only the Null-Modem cable will work with Cryo-con controllers. This cable is detailed in the RS-232 Connections section.</p> <p>Debugging tip: Cryo-con utility software can be used to talk to the controller over the RS-232 port using the terminal mode. All command and response strings are displayed. This is a good way to establish a connection.</p>
Intermittent lockup on RS-232 interface.	<p>Possible causes:</p> <p>Long cables. Try using a lower baud rate. In some cases, inserting a 50mS delay between commands will help.</p> <p>Noise pickup. Try using shielded cables with the shield connected to a metal backshell at both ends.</p> <p>Don't send reset (RST) commands to the controller before reading.</p>

Symptom	Condition
Can't talk to IEEE-488 interface.	<p>Possible causes:</p> <p>Ensure that the GPIB port is selected. Press the Sys key and scroll down to the RIO-Port: field.</p> <p>The IEEE-488 interface does not use terminator characters. Rather, it uses the hardware EOI handshake. Please review the GPIB Configuration section.</p> <p>Check that the controller's address matches the host computer's assignment. Press the Sys key and scroll down to the RIO-Address: field.</p> <p>Debugging tip: Cryo-con utility software can be used to talk to the controller over the IEEE-488 port using the terminal mode. All command and response strings are displayed. Since the software provides the proper interface setup, it is a good way to establish initial connection.</p>
Intermittent lockup on the IEEE-488 interface.	<p>Possible causes:</p> <p>Bus cables too long or too many loads on a single bus.</p> <p>Don't send reset commands before each query. This was common in early IEEE-488 systems.</p> <p>Ground loops: Some equipment manufacturers improperly connect the IEEE-488 Shield Ground wire to their circuit board ground. This can cause ground loops with equipment that is properly connected. Debug by disconnecting instruments from the bus.</p> <p>Use of unshielded bus cables.</p>

General problems

Symptom	Condition
Controller periodically resets, or resets when Control key is pressed.	<p>Generally caused by low AC line voltage. Check the AC voltage and ensure that it matches the instrument's voltage selection.</p> <p>AC line voltage selection is described in the Fuse Replacement and Voltage Selection section.</p>
Complete failure.	<p>Possible cause:</p> <p>Blown fuse. Check line voltage selection before installing new fuses. Review the Fuse Replacement and Voltage Selection section.</p> <p>Rack mounted instruments: Screws were used in the rack mount shelf that are too long and have penetrated the internal circuit board of the controller.</p>

Appendix C: Application Note on Signal Dither.

Using Dither in Digital Control Loops

“Dither”, as a signal or image processing technique, is a method of extending dynamic range by first perturbing (dithering) then averaging. The technique was first developed to enhance the performance of RADAR target algorithms and is now applied to a wide range of applications including navigation systems and consumer audio CD recordings.

Perhaps the most common example of a dithering technique is the synthesis of an artificial color on a computer screen by grouping available colors at adjacent pixels. When viewed by the user, the spatial averaging effect of the eye generates a color that is not available on the computer's color palette.

In Cryo-con's temperature controllers, dither is used to extend the dynamic range of a temperature control loop by outputting available power levels in a controlled sequence so that the average power is somewhere between the levels available in the controller's hardware. Here, the averaging function is performed by the system dynamics.

Control Accuracy

Major error sources in a digital control loop are: the input quantizer (ADC), the Digital Signal Processing mathematical operations and the output quantizer (DAC).

Cryo-con controllers use a 24-bit Analog-to-Digital converter. This is the best available with modern components and it establishes the measurement resolution of the controller. If all other functions were perfect, this ADC would also establish the accuracy of the control loop.

In order to preserve accuracy, the mathematical operations in a digital control loop must be performed to a much higher resolution than the input ADC. Therefore, Cryo-con controllers all use 32-bit floating-point arithmetic.

Finally, a high precision loop output value reaches the output quantizer, which is usually a 16- or 18- bit Digital-to-Analog converter. Since this DAC has much less resolution than the earlier stages, it generally establishes the accuracy of the accuracy of the entire loop. A loop output value has been generated to a very high precision, but the DAC throws away most of this precision to fit its available output levels.

Like the color synthesis example above, signal dithering can be applied to the digital control loop so that the average output value converges to the high precision value computed before output quantization. The result is much greater control accuracy.

Conventional Control Loop Output

The diagram to the right shows the conventional method of generating an analog output from a digital control loop. Here, a high precision loop output value is computed, then the value is truncated or rounded to fit the precision of the output DAC. Precision above the resolution of the DAC is lost.

In this example, the output DAC has four quantization levels labeled Q1 through Q4. Dashed lines show the mid-points between adjacent levels.

Here, the desired high-precision control loop output (o) is between levels Q2 and Q3. For simplicity, ten output intervals of a DC level are shown.

Using an arithmetic 'rounding' scheme, if the desired output is above the mid-point between two quantization levels, the DAC output will be at the higher level. If the value is below the mid-point, the DAC will output the lower level. Therefore, the DAC output (x) for the input shown will simply be Q3.

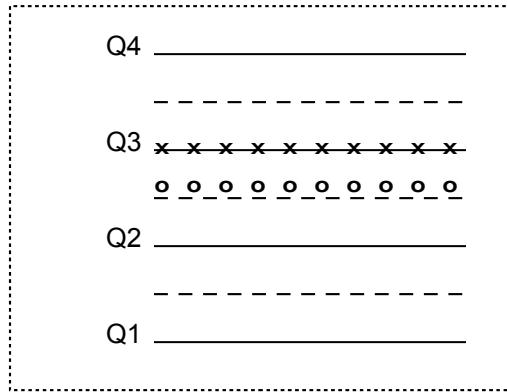

As can be seen, the average value of the DAC output is equal to the nearest quantization level. In this example, the output (Q3) is slightly higher than the value required to accurately control at the selected setpoint. Therefore, the control loop will integrate downwards until the DAC output jumps down to Q2. This process of jumping between Q2 and Q3 will continue, establishing an oscillation with an amplitude of one quantization level and a frequency related to the system's closed-loop time constant.

The Dither Algorithm

The signal dithering algorithm used in Cryo-con's digital control loop first generates a dither signal that is a random number within the range of ± 0.5 of a quantization level. This is then added to the loop output value just before placing it in the DAC.

If the sum of the desired output plus the dither value is above the midpoint between Q2 and Q3, the DAC will output Q3. If it is below the midpoint, the DAC will output Q2. Therefore, the DAC output toggles randomly between Q2 and Q3, but the number of times at one level vs. the other is weighted by how close the desired output is to the nearest quantization level.

In this example, the desired output is 25% of the distance from Q3 to Q2. Therefore, 75% of the DAC output samples will be Q3 and the remaining at Q2.

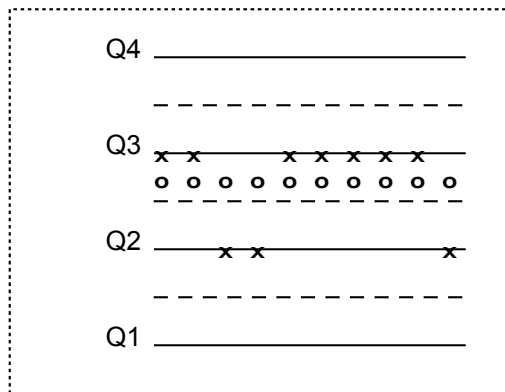

Most importantly, the average value of the DAC output converges to the desired output loop value.

Using this dither technique, the control loop output accuracy will improve as the number of averages increases; up to the limits imposed by the other elements of the control loop.

Fortunately, the number of samples averaged in a given system is proportional to its closed-loop bandwidth, which can be controlled by adjusting PID parameters.

How much improvement does dither provide?

Dither causes the average value of the control loop output to converge to the actual desired output. How close depends on the number of averages accumulated within the closed-loop system.

The accuracy of an estimate of average value for a fixed number of samples is given by the Chi-squared distribution. The 'degrees of freedom' used by this function is the number of samples accumulated.

Using the Cryo-con Model 32, the loop output rate is 10 samples per second. Therefore, if the process being controlled has a time constant on the order of 1.6 seconds, a total of 16 samples will be averaged, resulting in a factor of four improvement in control accuracy. This is equivalent to adding two bits to the output DAC.

Since the Model 32 uses a 16-bit output DAC, a 1.6 second closed-loop time constant will result in the equivalent of an 18-bit DAC. Note that 1.6 seconds is an extremely short time constant for a cryogenic temperature process.

Further Reading: "Introduction to Signal Processing", Sophocles J. Orfanidis, August 1995. Prentice Hall, ISBN: 0-13-209172-0
<http://www.ece.rutgers.edu/~orfanidi/intro2sp/>

Appendix D: Tuning Control Loops

Introduction

Tuning PID loops to maintain high accuracy control can be a laborious process since the time-constants in cryogenic systems are often long. Further, some systems must operate over a very wide range of temperature, requiring different PID settings at different setpoints.

The following is a guide to various methods of obtaining PID control loop coefficients.

Various methods for obtaining PID coefficients

The system provider

If your controller was received as part of a cryogenic system, the PID control loops should already be setup for optimum control. If the system operates over a wide range of temperature, it will use one of the available Table control modes where PID values are listed for different setpoints.

If the installed PID values do not provide stable control, you should contact the system manufacturer for assistance.

Taking PID values from a different controller

If the PID values required to control a system are known from a different type controller, these values may be useful.

The Proportional, or P term is a unit-less gain factor. There is no industry standard definition for it and, therefore, it can vary significantly from one manufacturer to another. If the P term does not work well when used directly, try using the value divided by ten. For further assistance, please contact Cryo-con support.

The Integral, or I term is in units of Seconds and should be the same for different controllers. Note however that some manufacturers use a 'Reset' value instead of directly using an Integral term. In this case, the Integral term is just the inverse of the Reset value.

The Derivative, or D gain term is in units of inverse Seconds and should be the same for various controllers.

Using Factory Default PID values

Controllers are shipped from the factory with very conservative PID values. They will give stable control in a wide range of systems, but will have very slow response times.

Often, the factory values provide a good start for the autotune process. The values are: P 0.1, I 5.0 and D 0.0.

Autotuning

Autotuning is the easiest way to obtain PID values, or optimize existing ones. Please review the [Autotuning](#) section of this manual.

Manual Tuning

The final, and most laborious method of tuning a control loop is manual tuning. This involves generating values for P, I and D by observing the system's response to the stimulus of the heater output.

Various methods of manually tuning the controller are described below.

Manual Tuning Procedures

Manually tuning a PID control loop is relatively simple. It is greatly assisted by use of a data-logging program, such as the Cryo-con utility software package described in the [Cryo-con Utility Software](#) section.

Ziegler-Nichols Frequency Response Method

This method is based on the assumption that a critically damped system is optimal and the fact that stability and noise must be traded for response time. It requires driving your system into temperature oscillation. Care should be taken so that this oscillation does not cause damage.

Enable the Over Temperature Disconnect feature of the controller if you are concerned about possible damage from overheating.

1. Enter a setpoint value that is a typical for the envisaged use of the system. Select a heater range that is safe for your equipment. Set initial PID values of Pgain=0.1, Igain=0 and Dgain=0.
2. Engage the control loops by pressing the **Control** key.
3. Increase the Pgain term until the system is just oscillating. Note the Pgain setting as the Ultimate Gain, K_c , and the period of oscillation as the Ultimate Period, T_c .
4. Set the PID values according to the following table:

Control Type	Pgain	Igain	Dgain
P only	$0.5 * K_c$	0	0
PI only	$0.4 * K_c$	$0.8 * T_c$	0
PID	$0.6 * K_c$	$0.5 * T_c$	$0.85 * T_c$

5. Wait for the system to stabilize. If the resultant heater power output reading is less than 10% of full scale, select the next lower heater range setting. A range change will not require re-tuning.

Note: In systems where there is high thermal noise, including cryocoolers, a Dgain value of zero is often used. The Dterm is a derivative action, which can introduce additional noise into the control process.

Alternate Methods

There are various other methods to manually tune PID loops. Most are based on graphical techniques and all use a stimulus-response technique.

For further reading:

Automatic Tuning of PID controllers
Instrument Society of America
67 Alexander Dr
PO Box 12277
Research Triangle Park, NC 27709

Appendix E: Sensor Calibration Curve Tables

Cryocon S700 Silicon Diode

The Cryocon S700 Silicon Diode sensor with a 10 μ A excitation current.

Volts	Temp (K)	Volts	Temp (K)	Volts	Temp (K)			
1	0.1633	475.0000	41	0.6393	260.0000	81	1.2510	18.00000
2	0.1733	470.0000	42	0.6586	250.0000	82	1.2720	17.00000
3	0.1834	465.0000	43	0.6807	240.0000	83	1.2950	16.00000
4	0.1935	460.0000	44	0.7040	230.0000	84	1.3280	15.00000
5	0.2038	455.0000	45	0.7238	220.0000	85	1.3650	14.00000
6	0.2141	450.0000	46	0.7461	210.0000	86	1.4150	13.00000
7	0.2246	445.0000	47	0.7682	200.0000	87	1.4700	12.00000
8	0.2351	440.0000	48	0.7916	190.0000	88	1.5270	11.00000
9	0.2458	435.0000	49	0.8133	180.0000	89	1.5750	10.00000
10	0.2565	430.0000	50	0.8338	170.0000	90	1.5990	9.50000
11	0.2673	425.0000	51	0.8547	160.0000	91	1.6230	9.00000
12	0.2781	420.0000	52	0.8753	150.0000	92	1.6540	8.50000
13	0.2891	415.0000	53	0.8977	140.0000	93	1.6670	8.00000
14	0.3001	410.0000	54	0.9198	130.0000	94	1.6840	7.50000
15	0.3111	405.0000	55	0.9373	120.0000	95	1.7080	7.00000
16	0.3222	400.0000	56	0.9542	110.0000	96	1.7310	6.50000
17	0.3334	395.0000	57	0.9768	100.0000	97	1.7500	6.00000
18	0.3446	390.0000	58	0.9865	95.00000	98	1.7690	5.50000
19	0.3558	385.0000	59	0.9950	90.00000	99	1.7850	5.00000
20	0.3671	380.0000	60	1.0050	85.00000	100	1.7970	4.75000
21	0.3784	375.0000	61	1.0144	80.00000	101	1.8000	4.50000
22	0.3897	370.0000	62	1.0241	75.00000	102	1.8090	4.25000
23	0.4011	365.0000	63	1.0325	70.00000	103	1.8160	4.00000
24	0.4125	360.0000	64	1.0420	65.00000	104	1.8210	3.75000
25	0.4239	355.0000	65	1.0506	60.00000	105	1.8270	3.50000
26	0.4353	350.0000	66	1.0587	55.00000	106	1.8340	3.25000
27	0.4467	345.0000	67	1.0673	50.00000	107	1.8390	3.00000
28	0.4581	340.0000	68	1.0753	45.00000	108	1.8460	2.75000
29	0.4695	335.0000	69	1.0842	40.00000	109	1.8520	2.50000
30	0.4808	330.0000	70	1.0870	38.00000	110	1.8560	2.25000
31	0.4922	325.0000	71	1.0904	36.00000	111	1.8590	2.00000
32	0.5035	320.0000	72	1.0941	34.00000	112	1.8630	1.75000
33	0.5148	315.0000	73	1.0974	32.00000	113	1.8660	1.50000
34	0.5261	310.0000	74	1.1011	30.00000			
35	0.5373	305.0000	75	1.1054	28.00000			
36	0.5485	300.0000	76	1.1108	26.00000			
36	0.5596	295.0000	77	1.1238	24.00000			
38	0.5707	290.0000	78	1.1650	22.00000			
39	0.5900	280.0000	79	1.2070	20.00000			
40	0.6131	270.0000	80	1.2290	19.00000			

S700 Silicon Diode Connections

The S700BB is a Silicon Diode temperature sensor. Connection is made using a color-coded four-wire, 36 AWG cryogenic ribbon cable.

Wires may be separated by dipping in Isopropyl Alcohol and then wiping clean.

Insulation is Formvar™ and is difficult to strip. Techniques include use of a mechanical stripper, scrapping with a razor blade and passing the wire quickly over a low flame.

S700 Cable Color Codes	
V+	Clear
V-	Green
I+	Black
I-	Red

Table 39: S700 Cable Color Codes

S700 Mounting

The S700BB bobbin is easily mounted with a #4-40 brass screw. A brass screw is recommended because thermal stress will be reduced at cryogenic temperature.

The mounting surface should be clean. A rinse with Isopropyl Alcohol is recommended.

First, apply a small amount of Apiezon™ N grease to the threads of the screw and on the mounting surface of the sensor package.

Next, place the bobbin on the mounting surface, insert screw through bobbin and lightly tighten.

INDEX

AC power.....	17, 21, 74	CalGen(.....	31, 63, 93, 96, 103, 114
connection.....	68	CalGen(.....	
cord.....	7, 74, 75	Diode Sensor.....	97
frequency.....	5, 41, 43, 87, 88, 148	Pt. Sensor.....	99
fuses.....	69	setup.....	96
low voltage.....	222	thermocouple.....	99
noise.....	93	calibration curve	47, 92, 103, 185, 188, 189, 208
power entry module.....	101	CONFIG commands.....	151
requirements.....	54	constant-voltage.....	55
smart on/off.....	17	CONTROL command.....	139, 141
Voltage Selection.....	69	CONTROL key.....	11
Adding a new sensor.....	78	Control LED.....	22
alarm.....		control type selection.....	36
audible.....	67, 165, 205	control types.....	171
clearing.....	28	CRV.....	103, 106
conditions.....	32	Cryocooler.....	
enable.....	30, 162	synchronous subtraction.....	87
high setpoint.....	30	thermal signature.....	87
hysteresis.....	32	current excitation.....	55
hysteresis.....	159, 160, 161	Curve 340.....	103, 106
latched.....	30, 32	data logging.....	103, 111
LED.....	22	configuration.....	111
low setpoint.....	30	Derivative gain.....	35
output.....	67	differentiator gain term.....	176
sensor fault.....	164	Display.....	
setpoint.....	30, 160, 161, 163	brightness.....	42
setup.....	32	configuration.....	22, 29
status.....	19, 159	Dual Input Status.....	29
viewing.....	28	Dual Loop Status.....	29
ASCII.....	133, 138	Loop Status.....	29
autocalibrate.....	145, 204	resolution.....	23, 42, 149, 204
Autotune.....	66, 194, 195, 196, 197, 198, 209	Statistics.....	29
Autotune.....		time-constant.....	41
remote commands.....	193	Dither.....	65
Autotuning.....	80	Electrical Isolation.....	63
modes.....	80	Enclosure.....	74
pre-tuning.....	81	Enclosure.....	
setup.....	82	dimensions.....	54
Beep command.....	142	weight.....	54
bias voltage selection.....	32	ENTER key.....	20
CALCUR commands.....	183	enumeration fields.....	19
CALDATA commands.....	190	ESC key.....	20

ESE.....	136, 137, 203
ESR.....	135, 136, 138, 203
Factory Defaults.....	5
restoring.....	15
firmware.....	
forcing download.....	16
revision level.....	1, 6, 138, 148, 204
update.....	103, 118
fuse replacement.....	69
fuses.....	69, 75
GPIO.....	43, 67, 134, 135, 136, 137, 143, 144
Hardware Revision Level.....	6, 147
Heater.....	
control modes.....	36
Dgain.....	34, 35
fault.....	65, 67, 146
lgain.....	34, 35
load.....	38
load resistance.....	34, 64
maximum output.....	4, 37, 173, 177, 178, 179
maximum setpoint.....	35, 37, 179
output.....	64, 65
Pgain.....	34, 35
Pman.....	34, 35
range.....	36, 44, 46, 64, 66, 173
read-back.....	65, 177
resistance selection.....	38
Safe Operating Area.....	64
setpoint.....	11, 21, 34, 46, 169, 170, 207, 228
setpoint.....	35
setpoint entry.....	27
shut down.....	64
source selection.....	35
status.....	23
HOME key.....	22
IEEE-488.....	5, 67, 103, 131, 137, 143, 144, 203, 222
IEEE-488.....	
address.....	143
connection.....	73
input channels.....	55, 153, 205
INPUT commands.....	153
input protection.....	63
input setup.....	30
input statistics.....	32
Instrument Calibration.....	123, 199
Instrument Calibration.....	
Calibration Interval.....	123
Calibration Services.....	123
Password.....	125
Procedure.....	123
Instrument Status Enable.....	134, 135
Instrument Status Register.....	134
integrator gain term.....	175
ISE 134, 135, 136	
ISR 134, 135, 136	
keypad keys.....	20
LogOhms.....	79
Loop #1.....	4, 64
connection.....	73
range selection.....	36
setup.....	33
Loop #2.....	33
connection.....	73
LOOP commands.....	169
loop status.....	25
manual control mode.....	35, 36, 66, 180, 181
Multiplier field.....	47, 58, 78
NTC resistor.....	56
OPC command.....	138
Operate Display.....	22
OTD.....	42
OTD.....	
enable.....	40
setpoint.....	41
source.....	40
OTDisconn.....	25
output power limit.....	37
Over Temperature Disconnect.....	25
Overtemp.....	25
OVERTEMP commands.....	181
PID	
coefficient.....	44, 193
configuration.....	35
control.....	66, 171
loop.....	66
mode.....	64
Table.....	37, 44, 64, 66, 103, 110, 171, 172, 186, 188, 189, 208
Table index selection.....	37

zone.....	44	Single-Point-Ground.....	101, 102
PID Table.....		Standard Event Register.....	135
File Format.....	186	Standard Event Status Enable.....	137, 203
PIDTABLE commands.....	186	STB.....	135, 136
POWER key.....	11	STOP command.....	139, 141
proportional gain.....	35, 175, 207	STOP key.....	11
Protective Ground.....	68	Supported Sensors.....	51
Ramping.....	85	Synchronous Filter.....	87
Algorithm.....	86	Configuration.....	43
operation.....	85	Setup.....	88
rate selection.....	38	Viewing.....	88
Setup.....	86	SYS-Auto Ctl.....	43
Ratiometric.....	55	SYSTEM commands.....	140
Readback.....	25	Table control mode.....	37, 44, 66
Real Time Monitor.....	110	Temperature.....	
Remote LED.....	22, 141	coefficient.....	47
remote transactions.....		history.....	32
viewing.....	43	ramp.....	174, 207
RS-232.....	43, 67, 144	units selection.....	31
RS-232.....		variance.....	32
connection.....	73	zones.....	66
RST command.....	138	Temperature Sensors.....	
S700.....	8, 231	CD-12A.....	12, 213
Color Codes.....	231	Cernox(.....	51, 57, 58, 61, 215
mounting.....	232	DT-470.....	12, 213
SCPI.....	67	DT-670.....	12, 213
command header.....	133, 134	Gallium-Arsenide.....	57
common command.....	133, 137	Germanium.....	58
compound command.....	133	NTC.....	57
keyword truncation.....	134	NTC resistor.....	58
simple command.....	133	Platinum.....	58
sensor.....		PT10K.....	12, 213
calibration curve.....	183	PT1K.....	12, 213
connection.....	51, 63, 70, 217	Rhodium-Iron.....	12, 57, 213
self-heating.....	55, 56	RO-600.....	12, 213
setup.....	47	RTD.....	12, 57, 213
table index.....	47	Ruthenium Oxide.....	12, 57, 58, 213
type.....	191, 208	S700.....	12
type selection.....	31, 47	SI-410.....	12, 213
units.....	31, 154	Silicon Diode.....	57, 213
Sensor Calibration Curve.....	106, 109, 185, 208	Thermistors.....	58
Sensor Calibration Curve.....		thermocouple.....	57
file format.....	183	Thermocouple.....	92, 94, 96, 114, 204
Sensor Setup Menu.....	190	Thermocouple.....	
SensorFlt.....	25	Adding new types.....	92

Calibration Errors.....	93	User Configurations.....	19, 39
Cold Junction Compensation.....	92	restore.....	39
connection.....	72, 92	save.....	39
Errors.....	92	select.....	39
Grounded.....	94	Utility Software.....	79
Offset Calibration.....	93	VFD display.....	17
Options.....	6	zone table.....	44
types.....	73	*IDN?.....	138, 203
Unit Name.....	147	*OPC?.....	138, 203
