

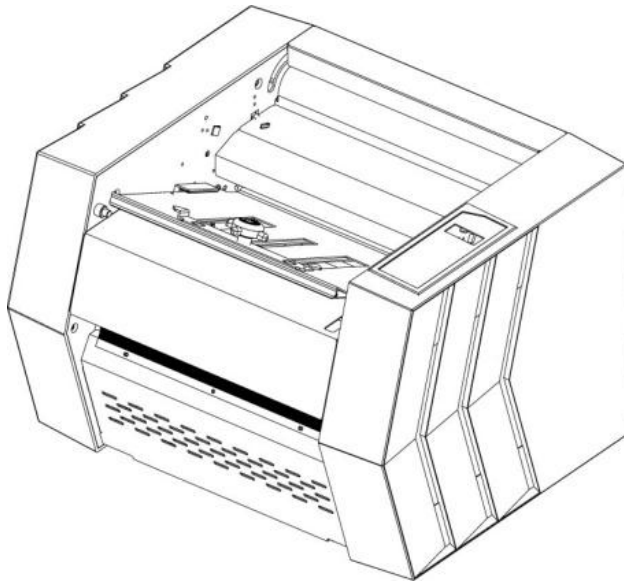

USER MANUAL

IM3100



Pressure sealer

This manual provides detailed information on how to operate and maintain your IM3100

Please read this manual before operating the machine in order to prevent any damage caused by improper handling.

Thank you for purchasing Paitec USA products.

Copyright

Any of the contents should not be copied, re-printed or translated by other languages without Paitec USA approval.

IM3100 is the registered trademark of Paitec USA

1. IM3100 Specification	-----	4
2. Identifying the parts	-----	5 ~ 6
3. Unpack the	-----	7
4. How to install the fold plate	-----	8
5. How to adjust the fold plate	-----	9
6. How to install the guide	-----	10
7. OP Guide	-----	11~14
8. Manual Feeding	-----	15
9. Paper jam removal	-----	16
10. Handling the error messages	-----	17
11. Maintenance	-----	18

IM3100 Features (Pressure Sealer)

- **Perfect Sealing Quality & Low Noise Level**

The most advanced pressure sealing technology with lightweight, excellent sealing quality and extremely low noise levels.

- **Excellent Folding Quality**

Excellent folding quality, even with plain paper based on our advanced technology.

- **Compact & Dynamic Design**

Advanced technology sealing system allows for compact design which saves valuable workspace.

- **Angle Seal Technology**

Innovative and exclusive angled seal technology provides superior sealing capabilities.

- **Inline Pressure Sealer**

IM3100 is compatible with several printers and it is very simple but useful.

IM3100 Specification

- Form Size : A4 / Letter / Legal size
- Speed : Maximum 3,000 forms / hour (Depends on the printer)
- Input Tray : From Printer
- Form weight : 60-120gsm
- Folding Setting : Z, C, V & Double, 14" uneven Z
- Manual Feed
- Batch Count Alarm
- Noise Level : less than 45db
- weight : 22kg
- Dimension : 320 X 390 X 280mm(WxLxH)

*Based on 80gsm paper weight.

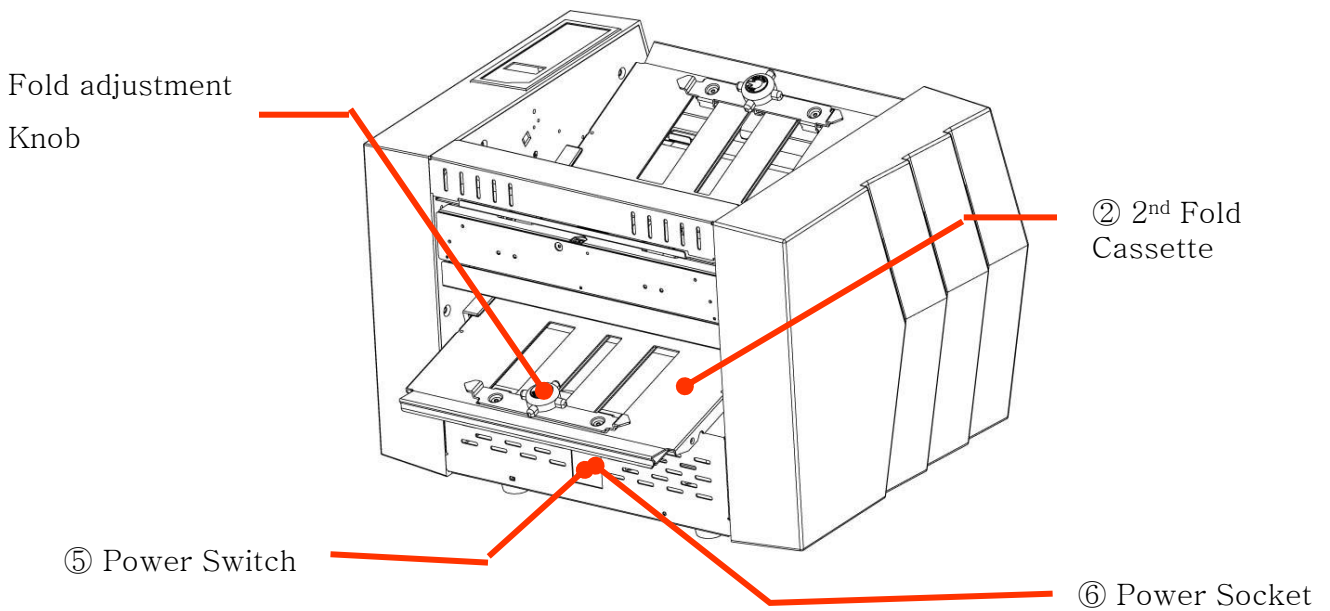
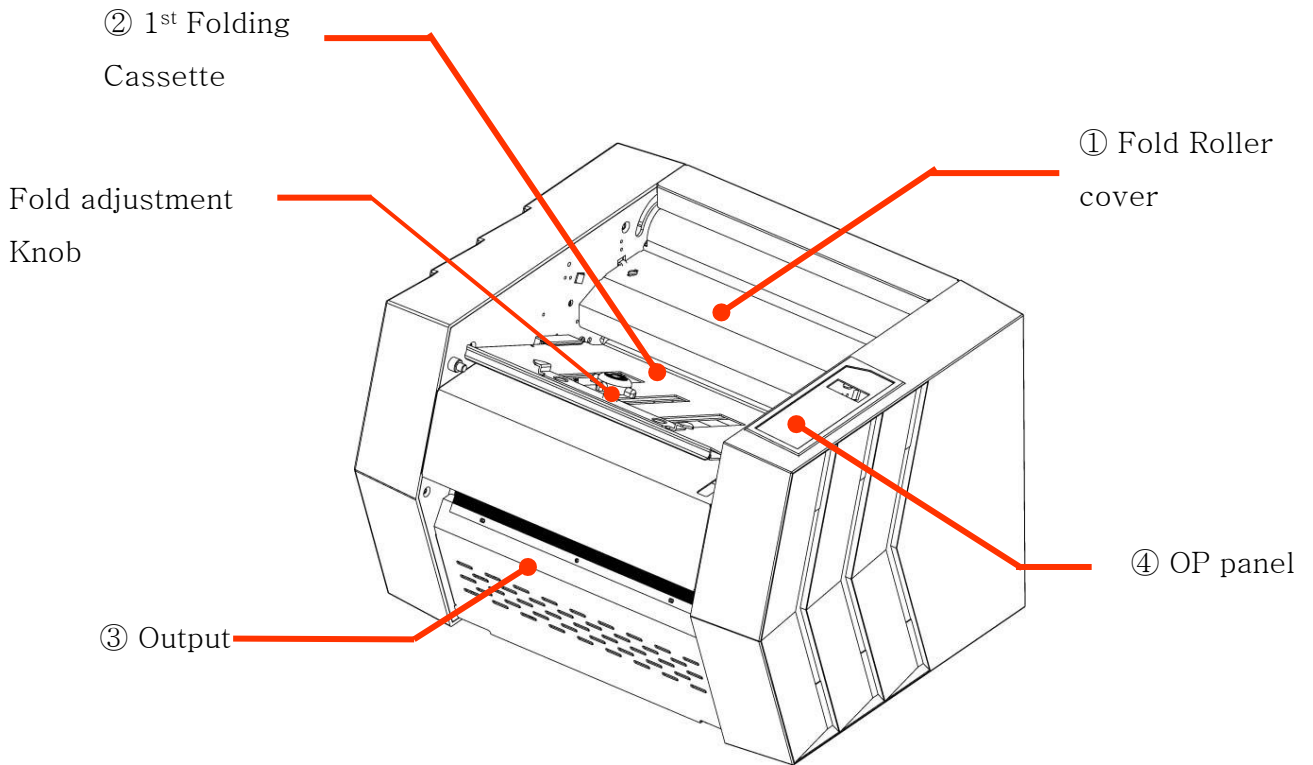

- 1 Roller cover**
 Open roller cover when jam occurs.
 (Please turn the Knob in clockwise rotation for unlock).
- 2 1st/2nd Folding Cassette**
 After 1st folding is made in the 1st folding cassette in front , 2nd folding is made in the 2nd folding cassette.
- 3 Output**
 Finished forms exit the front of the machine
- 4 OP panel for Start/Stop & other function**
- 5 Power switch**
 After check power socket, please turn on/off power switch
- 6 Power Socket**
 Main power socket located on the back of the machine

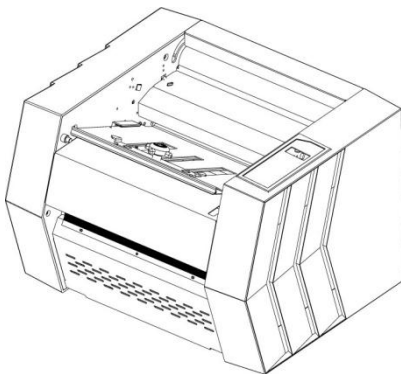

[Front View]

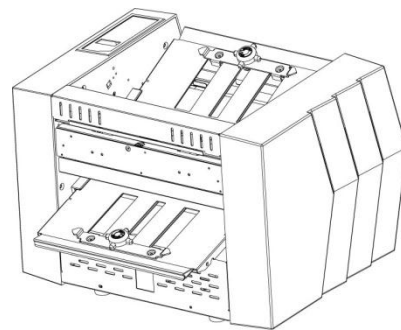

[Rear View]

Contents

Please check the following parts are included in the box.

Power cable, 1ST Fold Cassette, 2nd Fold Cassette, Output stacker User manual



[Unpack the Box]



[1st, 2nd Fold Cassette]

*Caution

Power connection : Please refer to the label for electric information which is located at the back of the machine. If it is not working properly, please contact your local dealer for service.

Adjusting the Fold Cassette

Insert the 1st Cassette (Pic. 1) on the front and 2nd Cassette on the back (Pic. 2)

Turn the Knob to adjust the fold cassette to the desired paper size (Refer to fold assist label on top of the in-feed tray.)

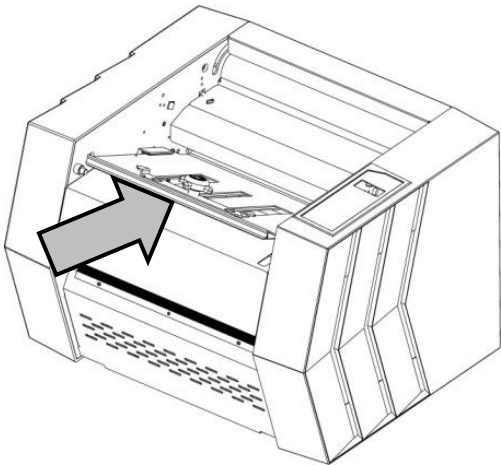

[Pic.1 : Set the 1st Cassette]

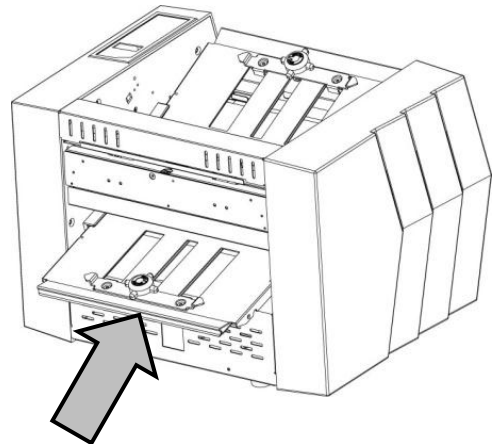

[Pic 2 : Set the 2nd Cassette]

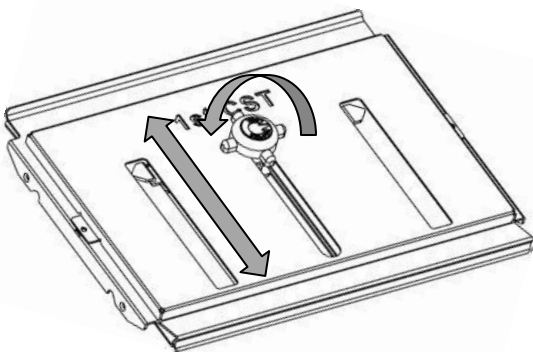

[Pic 3 : Adjust 1st Cassette]

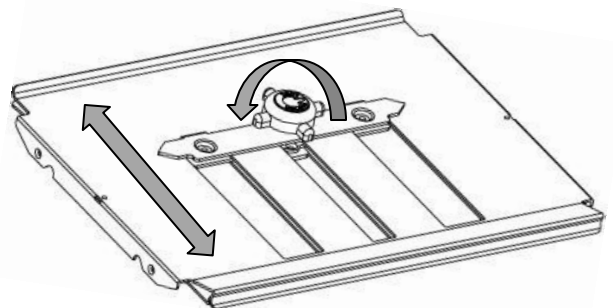

[Pic 4 : Adjust 2nd Cassette]

Folding Cassette Setting Guide

Fold cassette setting guide

		A4		Letter		Legal		Custom
		mm	Inch	mm	Inch	mm	Inch	Paper length X
Z - Fold	1-st	99	3.89	93	3.66	118.6	4.67	33.3%
	2-nd	99	3.89	93	3.66	118.6	4.67	33.3%
Uneven Z Fold	1-st	99	3.89	—	—	137	5.39	33.3%
	2-nd	102	4.01	—	—	140	5.51	34.3%
Single Fold	1-st	148.5	5.85	139.5	5.49	178	7.0	50.0%
	2-nd	Insert the cassette in the opposite direction						
C - Fold	1-st	198	7.8	186	7.32	237.2	9.34	66.6%
	2-nd	99	3.89	93	3.66	118.6	4.67	33.3%

How to set "Z-Fold"

- Swivel the Knob to counter clockwise and move on 99mm.
- Swivel the Knob to clockwise to tight and hold the position.
- 2nd Cassette is same as 1st Cassette.

! Attention : "C-Fold" is need to use 270mm Cassette(Pic. 3)

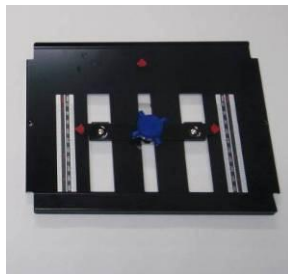

[Pic.1 : Standard 1st Cassette] [Pic. 2 : Standard 2nd Cassette]

[Pic. 3 : Option – 270mm Cassette]

How to assemble the guide

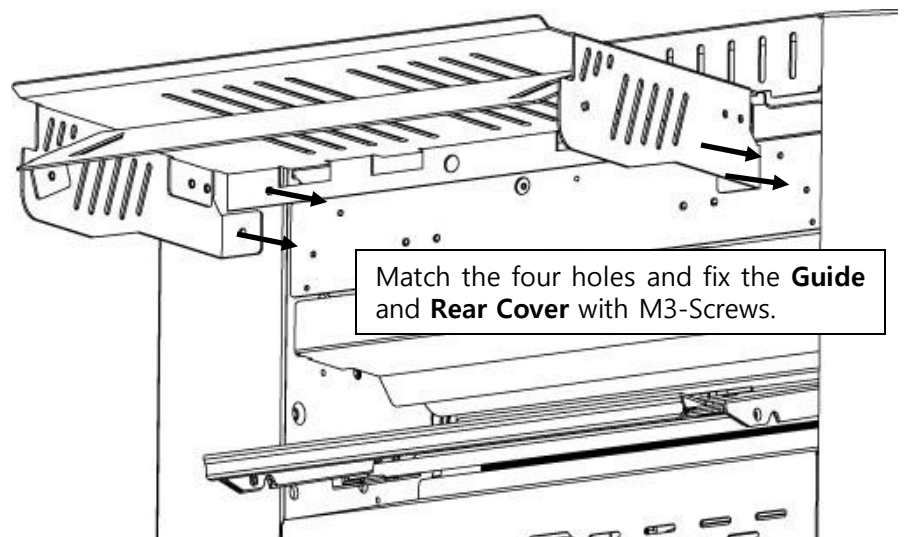
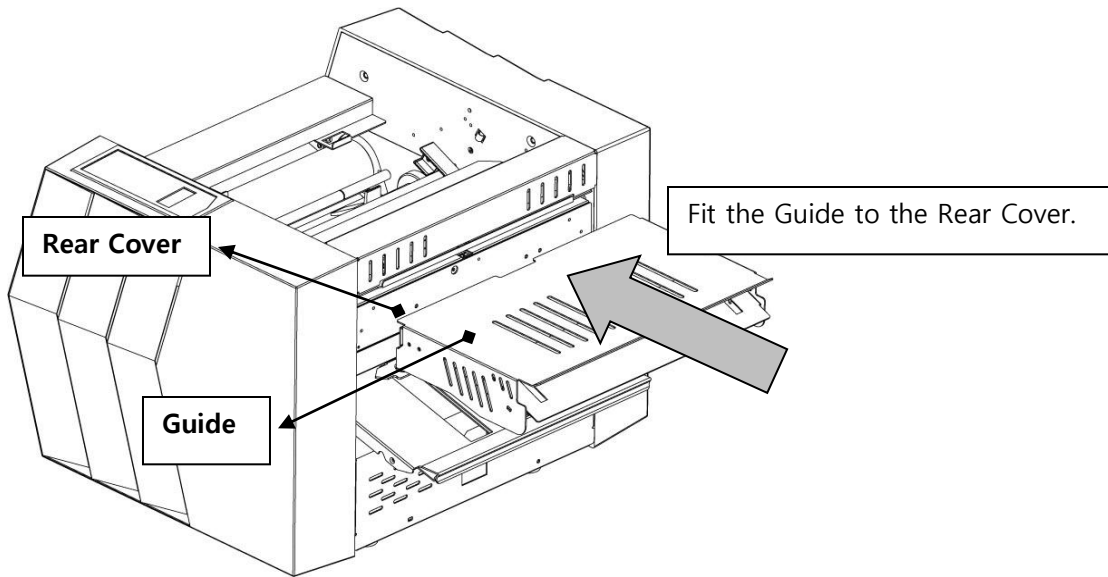

Operation Panel

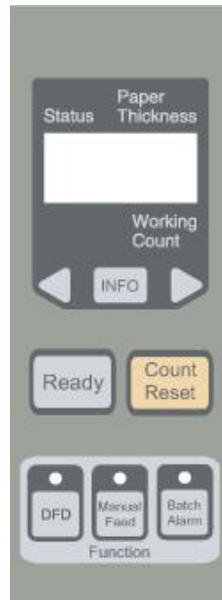

Count Reset

Please push a [**Count Reset**] button for initializing the working count on the Ready State.

Reset

[**Ready**] : Initialize the paper thickness .

- General Mode

[**Count Reset**] : working count is 0.

- Batch Alarm mode

[**Count Reset**] : batch counter is initialized, but working count is not initialized.

DFD (Double Feed Detection) on/off

If you do not want to use double detection function, you can make "DF mode" Off.

Press [**DFD**] and see disappearing "paper thick" on LCD.

Tip : You can use this function when the DFD is out of order because of the printed contents on the paper.

DFD Sensibility

DFD sensibility sometimes has to be changed for better detection.

Please hold the [**DFD**] button and change the "paper thick" value by using the [**Direction**] button. And for confirming and storing hold the [**DFD**] button again.

Batch Alarm Mode ON/OFF

Press [**Batch Alarm**] button for activating the batch count function. And press [**Batch Alarm**] button once again for deactivating the function.

Adjust Batch Count

The batch count adjusting menu is appeared through holding the [**Batch Alarm**] button.

You can change the value by using the [**Direction**] buttons and confirm the count by holding the [**Batch Alarm**] button again.

INFORMATION Menu

An information menu is appeared when the **[INFO]** button is pressed on the ready state.

1) What is the "Information" menu.

In this menu, a couple of information about the machine is showed.

And user can check the several settings and information about the OM3D easily.

2) Menu

- a) Total Count : The total count of the machine
- b) Paper Thick : The sensitivity of the DFD function.
- c) Firmware Version
- d) Installation Date : The date when the machine was installed.
- e) Total Usage Time : Measure the using time.
- f) Batch Count Alarm : The number of the batch mode.

For moving back to the ready state, press the **[INFO]** button again.

1. If the **[Count Reset]** is clicked a Working Count becomes '0' .
2. If the **[Ready]** is clicked the Paper Thickness is initialized.

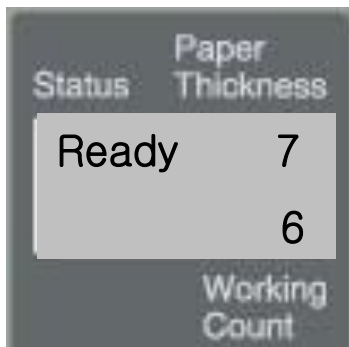

[Ready state]

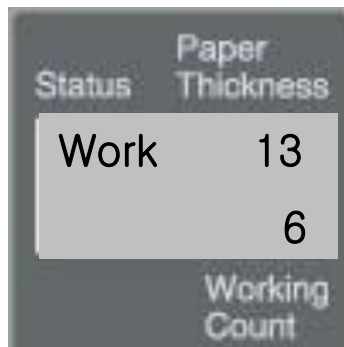

[Work state]

← [Paper thickness]

← [Working count]

Batch Count Mode

1. Check the 'Ready State' of the OP Panel.
2. Adjust the fold-position of the 1st and 2nd CST by using the setting guide of the fold-position[Page 11].
3. Press the **[Batch Alarm]** button and check the LED is turned on.
3. To hold the **[Batch Alarm]** button shows 'Batch count setting ' when the 'Batch mode' is activated. The number of batch count can be changed [from 1 to 200] every time the **[Direction]** buttons are pressed. And the count is changed fast for holding **[Direction]**
4. Hold the **[Batch Alarm]** button for saving the count.



[Count setting]

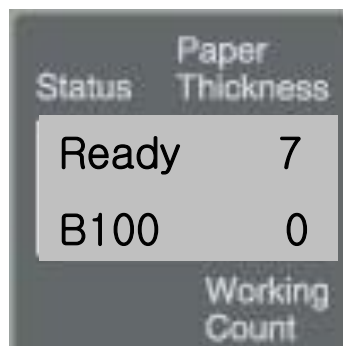

[Batch set]

MANUAL FEED

1. Press [**Manual Feed**] button and confirm 'Manual Feeding' is displayed on LCD.
2. Insert the paper into the manual feed guide.
3. AC motor starts to running firstly if the paper is detected by the infeed sensor and the paper is fed after two sec later.
4. The manual feed is turned off automatically after a paper was folded.

! CAUTION : Please pay attention that the clothes do not stuck into the press roller.

Paper Jam removal

Paper Jam Removal

The paper jam that is occurred in the IM3100 can be removed very easily.

The machine is stopped automatically when the paper jam is occurred. And the paper jam can be removed by using the jam removal tool.

Pull
the 1st CST

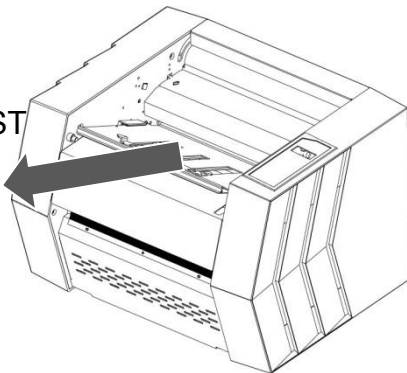

[Remove the 1st CST]

Open it.

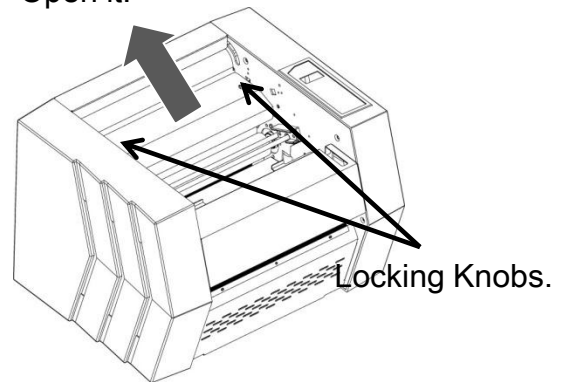

[Open the top cover by un-locking the locking knob.]

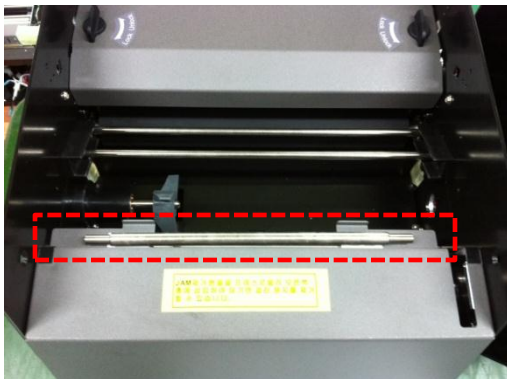

[Remove the jam by using the jam removal tool]

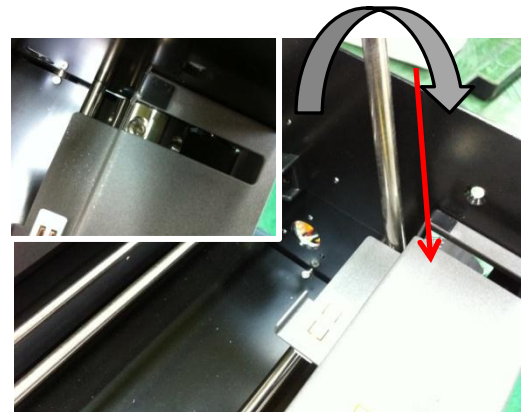

[Insert the tool into the hole on the press roller and rotate the press roller by hand]

! CAUTION : Please keep the jam removal tool to right position after removing the jam.

Handling the error messages.

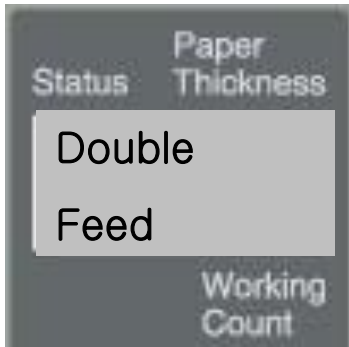

[Detect double feed & feed jam]

Open it.

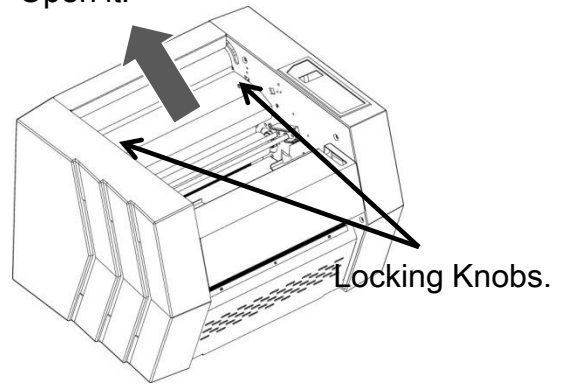

[Open the cover and remove the jam]



[1st Cassette Error]

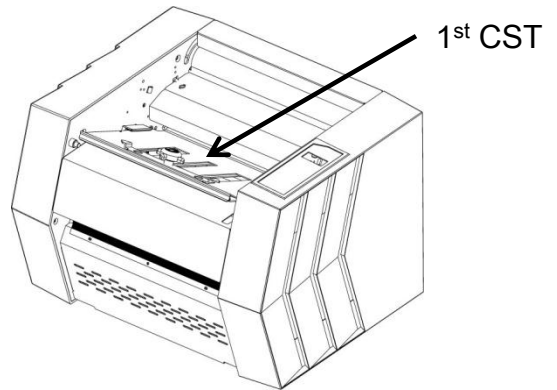

[Check 1st Cassette]

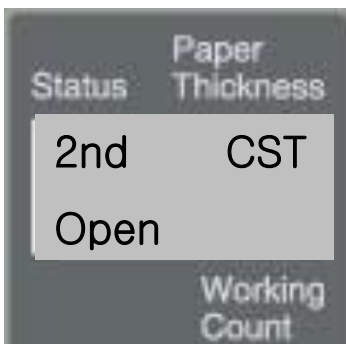

[2nd Cassette Error]

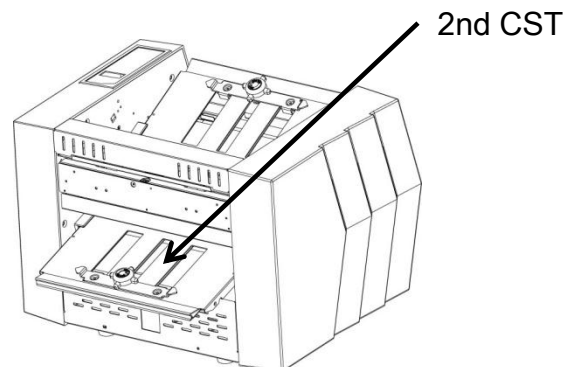

[Check 2nd Cassette]

Operator Maintenance

Due to the pressure seal forms leaving paper dust, ink and toner residues, it is very important to occasionally clean the surface of the each roller to ensure optimum performance.

In case of fold roller, remove 1st folding cassette and separate roller cover.
Clean ink and toner residues on the folding roller with this soft cloth wet through alcohol.

*Caution : Do not use oil as this will damage the surface of the folding roller.



[remove the forms]

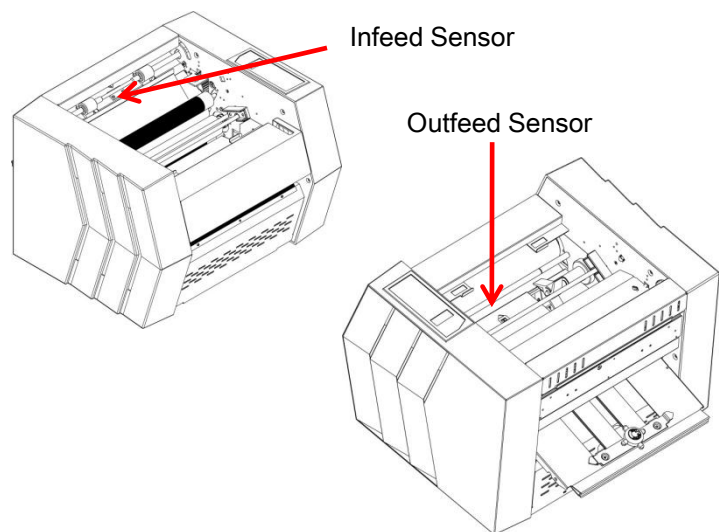

[clean the sensor]

This page is intentional left blank



Division of Pai Trading, Inc.
Headquarter & Factory
15951 SW 41st Street #400
Davie, FL 33331
www.paitec.com