

Hydrogen Leak Detector Sensistor ISH2000

Instrument SW version 6.22
Probe SW version 1.08



Publication: INFICON AB - nina60e1-d (1304) - All information can be modified without prior notice

Operating Manual



Contents

1	User information	6
1.1	Notes and safety notices	6
1.2	Document outline	6
1.3	Conventions used in this book	6
2	Description of equipment	7
2.1	Sensistor ISH2000	7
2.2	Sensistor ISH2000C	8
2.3	Sensistor ISH2000P	9
3	Controls and connections	10
3.1	Display	10
3.2	Push-buttons	11
3.3	LEDs	11
3.4	Ports and connections	11
4	Precautions	14
4.1	When working with gas	14
4.2	Hydrogen Tracer Gas for leak detection	15
4.3	Interferences	15
5	Working principle	16
5.1	Gas Sensor Technology	16
5.2	Condition for leak detection	16
5.3	Leak Detection mode	16
6	Operating the detector	17
6.1	To Detect Leaks	17
6.2	To Locate Leaks	17
6.3	To Quantify Leaks	18
7	Calibrate the leak detector	19
7.1	Introduction	19
7.2	Calibration Leak or Calibration Gas	19
7.3	Unit Conversion	19
7.4	Calibration procedure	20
7.5	Calibration value with Calibration leak	20
7.6	Calibration value with Calibration gas	21
8	Reference section	22
8.1	Menu system	22
8.2	Button functions	23
8.3	Stored values and setups	23
8.4	Engineering format	23
8.5	Change Test Mode	23
8.6	Calibration	23
8.7	Locating Mode Settings	27
8.8	Measuring Mode Settings	29
8.9	APC Settings*	31
8.10	Display Settings	32
8.11	General Settings	32
8.12	Service Settings	34
8.13	Combined Mode	36
8.14	Probe	36
8.15	Probe Control Port	37
8.16	Printer port	39
8.17	Sensistor ISH2000P installation	45
8.18	Default parameters	46
9	Trouble-shooting	49
10	Sensistor ISH2000 specifications	50
11	Spare parts and accessories	52
12	Support by INFICON	53
12.1	How To Contact INFICON	53
12.2	Returning your instrument to INFICON	53

13 Menu Overview 54
14 Declaration of conformity 56
15 Recycling 57

Welcome to Sensistor ISH2000

Dear customer,

You have just bought an INFICON Hydrogen Leak Detector Sensistor ISH2000. The Sensistor ISH2000 is an extremely sensitive and selective detector for hydrogen gas (H₂). It is especially designed for leak detection using Hydrogen Tracer Gas (Hydrogen diluted with Nitrogen down to a safe concentration) which is the most effective and economical tracer gas for leak testing.

Sensistor ISH2000 detects hydrogen in air at atmospheric pressure with no need for vacuum pumping. It is especially suitable for applications where high sensitivity and selectivity is required in combination with simplicity, reliability and low cost.

This product complies with the requirements of European Directives, listed in the Declaration of Conformity found on page 56 in this document. These Directives are amended by Directive 93/68/E.E.C (E.C. Marking).

Copyright/Intellectual property

The use of INFICON AB products are subject to copyright and intellectual property rights in force in any jurisdiction. All rights reserved, including copying this document in whole or in any part without prior written authorization from INFICON AB.

Though INFICON AB believes reasonable efforts have been made to ensure the accuracy of the information contained in the document, it may include inaccuracies or typographical errors. INFICON AB reserves the right to change the information inside the document without further notice.

1 User information

Read this user manual carefully before using the Sensistor ISH2000.

1.1 Notes and safety notices

This manual contains warnings and cautions concerning the safe use of the product. See definitions below.



WARNING!

Warning indicates a hazardous situation which, if not avoided, could result in death or serious injury. It is important not to proceed until all stated conditions are met and clearly understood.



CAUTION!

Caution indicates a hazardous situation which, if not avoided, could result in minor or moderate injury. It is important not to proceed until all stated conditions are met and clearly understood.



NOTICE!

Notice indicates instructions that must be followed to avoid damage to the Sensistor ISH2000 or other equipment.

Note: A Note is used to indicate information that is important for trouble-free and optimal use of the Sensistor ISH2000.

1.2 Document outline

The document is divided in two main parts:

- Getting started
- Reference section

The Getting started part consists of step by step case examples, explaining how to use the Sensistor ISH2000 in a variety common situations. The Reference section consists of in depth explanation and additional information, which completes the user manual with all relevant information.

1.3 Conventions used in this book

In this user manual the following text style (*hardware command*) is used for references to hardware commands or button labels, while this text style (*software command*) is used for references to software commands and menu choices.

2 Description of equipment

Sensistor ISH2000 can be purchased in one of three versions. A desktop model (Sensistor ISH2000), a battery operated model (Sensistor ISH2000C), and a panel mount model (Sensistor ISH2000P).

2.1 Sensistor ISH2000

Sensistor ISH2000 is equipped with a number of powerful functions making it very easy to integrate in a semi or fully automatic test system. The functions range from output of all necessary status signals and printer/communication port to an advanced Active Probe Control system (APC). This makes the detector capable of controlling advanced sample collecting devices down to simple test fixtures.

Fig 2-1. The desktop model consists of seven parts.



Item	Description
1	Detector instrument
2	Hand Probe P50 (shown) or Active Probe with sensor
3	Probe cable C21
4	Power cable (the power cable is country specific and may differ)
5	User manual (not shown)
6	User manual in electronic form (on CD or USB memory stick)
7	Product return form (not shown)

2.2 Sensistor ISH2000C

The battery operated model, Sensistor ISH2000C, has all the Sensistor ISH2000 features apart from the APC system. This means that only passive probes (for example Hand Probe P50) can be used. This is due to power management control. The battery, a Li-ion battery at 14.8 V, can not support the current required to operate external probes.

On the display a symbol in the upper right corner shows the battery charge status. Sensistor ISH2000C will operate for 14 hours on a fully charged battery with screensaver and mute function. And 9 hours without screensaver and mute function.

One hour charging will give about one hour of operating time. This can be done when necessary, but it is important to regularly fully charge the battery.

Fig 2-2. The battery operated model consists of seven parts.



Item	Description
1	Detector Instrument
2	Hand Probe P50 (shown) or P50-Flex
3	Probe cable C21
4	Carrying case
5	Battery charger (the battery charger are country specific and may differ, not shown).
6	User manual (not shown)
7	User manual in electronic form (on CD or USB memory stick)
8	Product return form (not shown)

2.3 Sensistor ISH2000P

The panel mount model, Sensistor ISH2000P, has identical features of the Sensistor ISH2000.

The difference is that the Sensistor ISH2000P can be installed in the operator's panel or any other flat surface. The instrument operates on an external +24VCD power supply, provided by the customer. Mounting brackets and a panel rubber seal are delivered with the detector. See "Sensistor ISH2000P installation" on page 45.

Fig 2-3. The panel mount model consists of seven parts.



Item	Description
1	Detector instrument
2	Brackets (not shown)
3	Screws (not shown)
4	O-rings seal (not shown)
5	User manual (not shown)
6	User manual in electronic form (on CD or USB memory stick)
7	Product return form (not shown)

3 Controls and connections

The controls and connections are discussed and shown in this chapter.

Fig 3-1. Sensistor ISH2000 controls and indicators

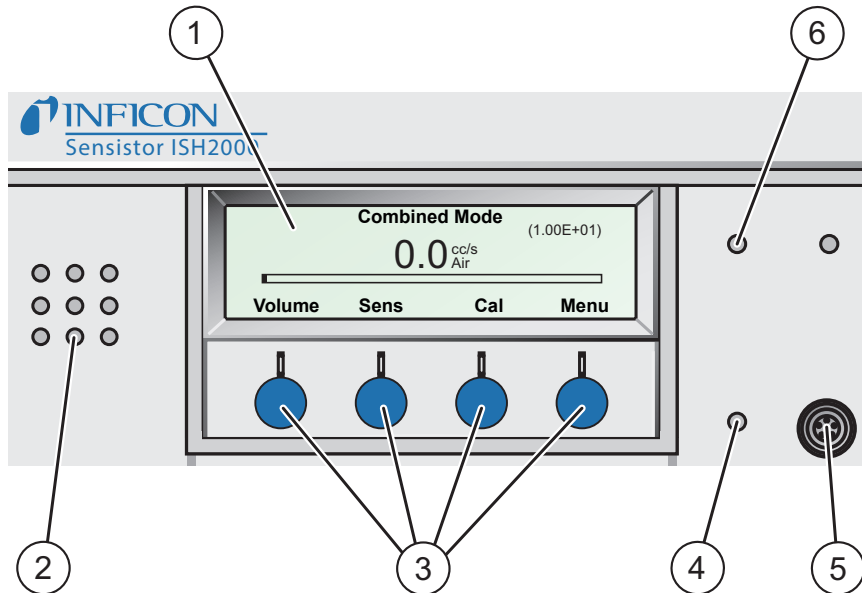

Item	Description
1	Display
2	Loudspeaker
3	Control push-buttons
4	Earphone socket
5	Probe connector
6	LEDs

3.1 Display

The display shows:

- Indicator bar in Locating Mode and the figures in Measuring Mode.
- Eight main menus. Their positions are indicated on a horizontal scale. Change from one menu to another using the < and > buttons.
- Main menus have sub-menus, which are also indicated by horizontal scales and can be selected using the < and > buttons.
- Scales for setting numeric values, languages, etc.
- Messages.

Sensistor ISH2000C:

- A battery status indicator in the upper right corner.

3.2 Push-buttons

The functions of the push-buttons are shown at the lower edge of the display. In this manual the buttons are numbered, from left to right, 1, 2, 3, and 4. The push-buttons are used to:

- Change from one menu item to another using the < and > buttons.
 - Press Enter to move down to the nearest sub-menu.
 - Press Save to save the set value.
 - Press Undo to restore the previously set value.
 - Press Esc to move up to the nearest higher level(s).
 - Shortcut to reach functions as Volume Sensitivity (Sens), Calibration (Cal) and Menu.
-

3.3 LEDs

The two LEDs indicate the status of the instrument as follows:

- Green flashing slowly, during warming up phase.
 - Green fixed light indicates that instrument is ready and hydrogen signal is below Reject Level limit.
 - Periodically flashing green or red calls for calibration.
 - Alternating red and green light while the instrument establishes probe communication.
 - Red fixed light together with *Reject* on display means the instrument has detected a leak larger than the set Reject Level limit.
 - Red flashing rapidly, check message on screen. (See "Trouble-shooting" on page 49.)
-

3.4 Ports and connections

The ports and connections are shown in Figure 3-2 on the next page.



NOTICE!

Always connect all four wires to the Power connector to 24VDC in order to operate.

Sensistor ISH2000

Fig 3-2. Sensistor ISH2000 ports and connections (rear view).

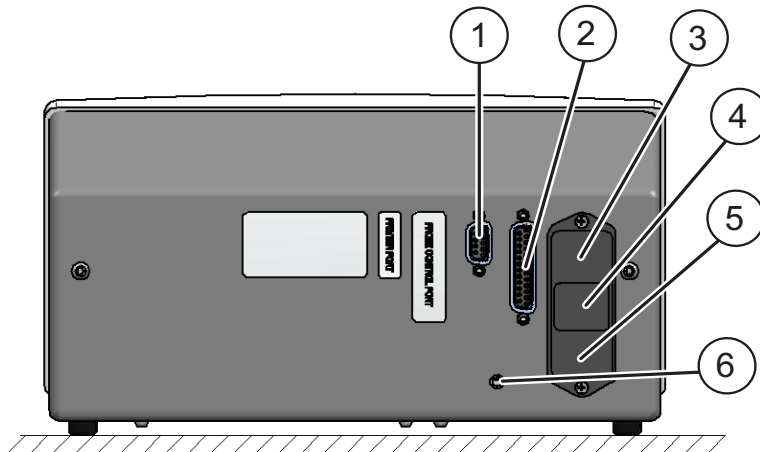

Item	Description
1	Data output
2	Probe control port
3	Fuse
4	Power switch
5	Power input, 100-240 VAC
6	Screw hole for mounting plate

Sensistor ISH2000C

Fig 3-3. Sensistor ISH2000C ports and connections (rear view).

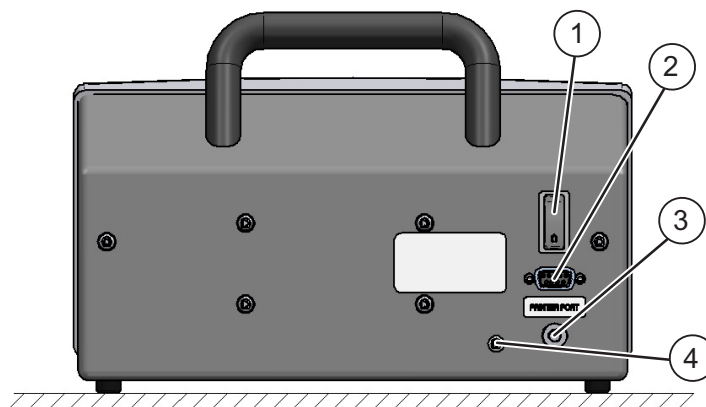

Item	Description
1	Power switch
2	Printer port
3	Power input (From Battery charger)
4	Screw hole for mounting plate

Sensistor ISH2000P

Fig 3-4. Sensistor ISH2000P ports and connections (rear view).

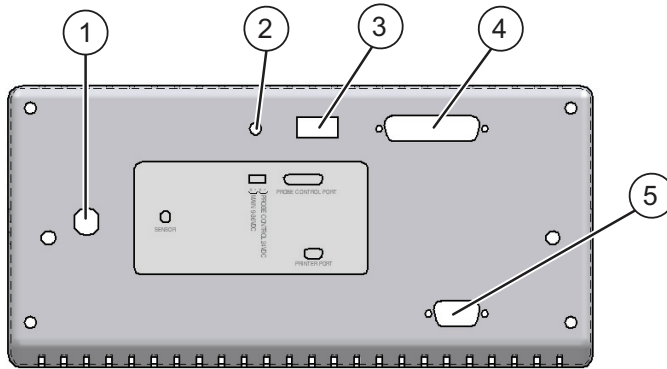

Item	Description
1	Probe connection
2	Ground screw
3	Power input (24 VDC)
4	Probe control port
5	Printer port

4 Precautions

Read this user manual carefully before using the instrument. Hydrogen Leak Detector Sensistor ISH2000 is extremely selective. Only Hydrogen Sulphide (extremely toxic) gives a comparable response to hydrogen.

4.1 When working with gas

The normal risks associated with working with all compressed gases must be considered.

**WARNING!**

Pure hydrogen is a flammable gas. Only use ready-made Hydrogen Tracer Gas of 5% Hydrogen in Nitrogen. This is a standard industrial gas mixture used in various industrial applications.

Note: Whenever the word Hydrogen is used in this manual it implies that the hydrogen gas is safely mixed with Nitrogen in the proportions 5% H₂ - 95% N₂.

**WARNING!**

Since the tracer gas mix contains no oxygen, releasing large amounts of gas in a confined space may lead to asphyxiation.

**WARNING!**

Compressed gases contain a great deal of stored energy. Always carefully secure gas bottles before connecting pressure regulator. Never transport gas bottle with the pressure regulator fitted.

Before connecting tracer gas: confirm that the connectors and test object is designed for working at the test pressure.

**WARNING!**

Pressurising objects at too high pressures can result in a burst object. This in turn can result in serious injury or even death.

Never pressurise objects that have not previously been burst tested or otherwise approved for the chosen test pressure.

Note: INFICON AB can not take any responsibility for the consequences arising from the inappropriate use of certain test pressures.

Pressure shocks might cause strong sounds which can cause impairment of hearing. Check that all relevant legislation and safety standards are complied with before putting Sensistor ISH2000 into service.

4.2 Hydrogen Tracer Gas for leak detection

When pure hydrogen gas is released in air its flammability range spans from 4% to 75% of hydrogen in air. Below 4% there is insufficient chemical energy available for a flame to occur. Above 75% hydrogen there is not enough oxygen left to support a flame.

When, for example, a mixture of less than 5.5% hydrogen in nitrogen mixes with air there is not sufficient energy to support a flame, irrespective of the ratio of air-to-gas.

When a mixture of more than 5.5% hydrogen in nitrogen is released into air there is a region of ratios of air-to-gas where the mixture is flammable. When, for example, a mixture of 10% hydrogen in nitrogen mixes with air there is still very little energy available. Only in exceptional circumstances can a flame be self-supporting. However, such mixtures cannot detonate.



WARNING!

Hydrogen/nitrogen mixtures containing approximately more than 15% hydrogen can detonate when mixed in certain proportions with air.



NOTICE!

Never make your own mixtures. Only use ready-made mixtures or use a certified hydrogen/nitrogen mixture mixer installed by your gas supplier.

4.3 Interferences

Most tracer gas methods suffer from some sort of interference. Either the detector is sensitive to other gases or vapors, or there are other sources of the gas present to which the detector is sensitive.

Some examples of possible hydrogen sources:

- Engine exhaust
 - Battery charging stations
 - Cigarette smoke
 - Breathing air
 - Human flatulence
 - Scratching on aluminum surfaces
-

5 Working principle

5.1 Gas Sensor Technology

The Sensistor ISH2000 leak detector is using an extremely sensitive hydrogen gas sensor based on a metal-oxide-semiconductor field-effect-transistor (MOS-FET).

The gas sensitivity appears when hydrogen absorbs into the sensor through a metal alloy (metal hydride) layer.

Only hydrogen can diffuse into the metal and this makes the sensors practically insensitive to other substances that do not contain free hydrogen molecules.

The signals from the sensors are processed by a microprocessor which also controls the sensor temperature with high accuracy, and other sensor diagnostics in order to ensure perfect functionality. It also automatically compensates for background gas.

5.2 Condition for leak detection

To use the leak detector the test object must be filled and pressurized by tracer gas (95% N₂/ 5% H₂) to get a gas flow through the leak. The tracer gas is a standard welding gas of industry quality, easy to obtain at low cost. The generic name is Forming Gas. Appropriate gas filling equipment can be obtained from the leak detector supplier.

Be careful of how tracer gases are handled after use. Released tracer gas contaminates the surrounding air with hydrogen and can complicate the following measurements for a time. Ensure that the tracer gas is ventilated away from the target area, preferably to the outside of the building.

5.3 Leak Detection mode

The detector operates in three modes:

- Locating Mode is mainly used for detecting and locating leaks but not quantifying them.
- Measuring Mode measures the concentration of hydrogen.
- Combined Mode, (default mode) which is a combination of Locating and Measuring Mode.

The Locating Mode operates continuously while the Measuring Mode determines the hydrogen concentration (and calculates a corresponding leak rate) in a step measurement. Locating Mode gives no numbers. It therefore needs no actual calibration. The sensitivity of the sound signal and the moving bar on the display is set manually or automatically, see below.

When using the instrument in Measuring Mode, it must be calibrated as described. See "Calibrate the leak detector" on page 19 in order to give correct figures.

6 Operating the detector

6.1 To Detect Leaks

If all you wish to do is to detect the presence of a leak, that is, find out whether there is a leak or not, then use the **Locating Mode** (or use the Locating bar in **Combined Mode**). The definition of Leak/No Leak will then simply be "A leak is a leak when it can be detected by the detector, set to a specific sensitivity".

To set up:

The operation in **Locating Mode** is not quantitative. The audio and visual signal will increase and decrease with the gas concentration. Therefore, there is no actual calibration to be done, but rather a setting of the sensitivity to a desired level.

A typical set-up procedure for **Locating Mode** is:

- Set up a Calibration leak which corresponds to the smallest leak you wish to detect.
- Put the probe close to the Calibration leak and note approximately what reaction you get (no reaction, small, medium, high, full scale) within the first few seconds.
- Set the sensitivity. This can be done permanently under the menu **Locating Mode Settings** or temporarily as a **Direct Sensitivity Adjustment** on the display (unless you have set this function to OFF under the Locating Mode Settings menu).

There is also an Auto ranging function which can be selected under the Locating Mode Settings menu.

Note: If the **Locating Mode** is used and the alarm function is required to be activated at a particular calibrated level, then the unit must be calibrated in accordance with the instructions, see "Calibrate the leak detector" on page 19. The reason for this is that the alarm is based on the **Measuring Mode** when the **Locating Mode** is displayed.

6.2 To Locate Leaks

Note: The **Locating Mode** (or use the Locating bar in **Combined Mode**) is used to locate leaks. This mode is semi-quantitative, that is, it gives an audio and visual signal which increases as a leak is approached (a higher gas concentration) and decreases as you move the probe away from the leak. It does not display figures. In this mode of operation leaks can easily be detected using a sensitivity which can be preset. See "Sensitivity" on page 28 and "Direct Sensitivity Adjustment" on page 28.

Leaks can be located very accurately, even when there are other leaks nearby. If, for example, you are trying to locate a leak on a product and the product has a major leak, then you will get an audio signal as soon as the probe is placed close to the product. When the probe is moved around and over the product, the signal will increase as the probe approaches the leak. If the signal goes out of scale, simply reduce the sensitivity setting to bring the signal within the scale. Working with the sensitivity setting this way you will be able to locate multiple leaks that are in close proximity to each other.

Note: Working inside a confined space such as, for example, a cabinet or a narrow passage on a combustion engine there is a risk that the background concentration accumulates to levels close to the upper detection limit of the detector. In such case it will not be possible to locate leaks as easily as in open spaces.

Hint: It is good practice to detect a leak, locate it, and immediately remove the probe to avoid saturation. The probe is not damaged by the exposure but it will recover more slowly. After excessive exposure it will be less sensitive for a short period of time.

6.3 To Quantify Leaks

The **Measuring Mode** (or use the figures in **Combined Mode**) is used for measuring the size of a leak (or the concentration of a gas sample). To be able to do this measurement and obtain correct values, the instrument must first be calibrated using the calibration function.

In the **Measuring Mode** the detector determines the gas concentration from the change, as the probe goes from being exposed to background to being exposed to a certain gas concentration. The detector does not continuously monitor the gas concentration but takes just one reading instead. Another suitable alternative name for this mode could be Sampling Mode. It is important to keep this in mind when using the detector in this mode.

In **Measuring Mode** the probe should be moved directly from a background situation to the test point. The size of the leak in cc/s, or any other selected units, is shown on the display. The probe can and should be removed from the measuring point as the measured value steady and remains on the display. The period during which the measured value is displayed can be adjusted in the **Measuring Mode Settings** menu.

The leak detector operates in the range 0.5 - 2000 ppm H₂ giving linearity between 0.5 and 500 ppm. To obtain greatest accuracy over this range, follow the calibration recommendation. See "Calibrate the leak detector" on page 19.



CAUTION!

- Do not open detector! Service of this equipment may only be carried out by service organizations authorized therefore by INFICON, Sweden.
- If the detector gets outer damage it must be controlled and repaired by service organization authorized by INFICON.
- Do not expose the probe to a hydrogen concentration higher than 0.1% when the instrument is not put into operation, this might damage or destroy the probe sensor.
- When the instrument is put into operation the sensor withstands temporary exposure to hydrogen concentration up to 100%. Avoid long exposures to high concentrations.

7 Calibrate the leak detector

7.1 Introduction

The leak detector is the instrument and the probe together.

This section of the operating manual consists of step by step examples on how to calibrate the detector in the most common cases. For more about the calibration routine, see the reference section.

The instrument must be calibrated by using the integrated calibration function to make sure it displays the correct values in Measuring Mode. After calibration, the instrument will show the correct measured values on the display in *Measuring Mode* and in *Combined Mode*. The calibration parameters will be stored in the probe.

7.2 Calibration Leak or Calibration Gas

There is a possibility to calibrate the detector by using Calibration Gas or a Calibration Leak.

A Calibration Gas contains a well-defined concentration of Hydrogen gas mixed with air. A Certificate will normally follow the gas bottles. Calibration Gas can be ordered from local gas suppliers.

A Calibration Leak is a well-defined gas leak. The Calibration Leak should be fed by the same gas used in the detection test and with a gas pressure defined in the Calibration Leak certificate. Calibration Leak can be ordered from the detector provider.

Choose a calibration leak or calibration gas size, as follows:

- Same or higher than the Reject Level (but maximum 10 times higher)
- In one of the following ranges:
 - 5 to 400 ppm H₂
 - 1x10⁻⁵ to 4x10⁻³ cc/s (mbarl/s) defined for air
 - 3 to 120 g/yr defined for R134a

Please contact the provider of the detector for help to select optimal calibration reference for your application.

7.3 Unit Conversion

When using flow units (other than “ppm” and “custom”), the instrument automatically converts between the calibration unit and the measurement unit. The conversion is saved in the *Correlation value* and is updated when *Calibration Unit* or *Measuring Unit* is changed. *Leak Gas* and *Displayed Gas* will not change *Correlation Value*, but will have effect on the measured figures.

If “ppm” or custom unit is chosen (*Measuring* or *Calibration Unit*), the *Correlation Value* must be set by operator. To set *Correlation Value* go to menu *General Settings*.

Correlation Value can be modified even otherwise.

7.4 Calibration procedure

Before calibration, the *Calibration Value*, *Calibration Unit* and *Leak Gas* in the *Calibration Menu* must be set. See "Calibration value with Calibration leak" and "Calibration value with Calibration gas" below.

Let the instrument be in operation for at least 30 minutes to achieve the best conditions for a calibration.

When calibrating, do the following steps:

1. Go to Menu then Calibration/Calibrate/Enter or just push the button "Cal" on the main screen.
2. Expose the probe to background.
3. Push the Start button or push the probe button.
4. Expose the probe for the Calibration gas/leak

The probe does not have to be exposed to the calibration gas during the entire *Calibration Time* (the time set in the *Calibration* menu while the bar is moving). The instrument only measures the change as the probe goes from the background air to calibration gas.

While the calibration time bar is moving, the probe should be exposed to the Calibration gas or Calibration leak. Wait until the instrument shows "Gas detected" and gives a sound signal. Repeat until you can save the calibration by pressing Save or probe button. If the calibration is not saved, the instrument will revert to the previous value after one minute.

Note: You will need to repeat the gas exposure procedures 2-3 times to get *Calibration OK* after changing setup or probe. The text "*Calibration failed! Check leak/gas and sensor status*" (or a custom text) will appear after 5 attempts.

- Allow at least 30 seconds between each exposure for best accuracy!
- If the message "*No gas or Unstable Signal*" is displayed repeatedly - go back to Locating Mode and check functionality.
- If "*Calibration in progress. Please repeat again*" is displayed it means that the measured value deviated more than 10% from the previous calibration. Repeat the calibration procedure.

7.5 Calibration value with Calibration leak

When measuring leak flow you will, in normal cases, calibrate the detector with a Calibration leak.

Set the *Calibration Value* equal to the calibrated flow of your Calibration leak. Also set the *Calibration Unit* to the same unit as that used to express the leak rate of the Calibration leak. Finally set the Leak Gas that the leak is defined for. These values can be found on the calibration certificate issued for the leak. Finally set the Leak Gas that the leak is defined for. These values can be found on the calibration certificate issued for the leak.

Example: Calibration leak rate is defined to: 4.2E-5 mbarl/s for Helium.

1- Set *Calibration Value* = 4.2E-05.

2- Set *Calibration Unit* = "mbarl/s"

3- Set *Leak Gas* = Helium

Note: Feed the Calibration leak with hydrogen tracer gas at the pressure stated on the Calibration certificate. If another pressure is used you must correlate the resulting flow and use this value as *Calibration Value*.

Note: The resulted concentration from the Calibration leak should be within the concentration range of 5 ppm - 400 ppm H₂.

7.6 Calibration value with Calibration gas

When measuring hydrogen concentration (instead of leak flow) in most cases you will calibrate the detector to a Calibration gas with a known concentration.

Set the *Calibration Value* equal to the Hydrogen concentration in your Calibration gas. This can be found on the certificate of analysis issued for the gas. Also set the *Calibration Unit* to ppm.

Example: Calibration gas contains 10 ppm Hydrogen in synthetic air.

1- Set the *Calibration Value* = 10

2- Set the *Calibration Unit* = "PPM"

8 Reference section

This section of the user manual consists of an in-depth explanation and additional information, which completes the operating manual with all relevant information.

8.1 Menu system

The menu system is designed as a tree structure similar to that used in mobile telephones. The display shows all the levels when browsing down through the menus so that you can always see exactly where you are. See "Menu Overview" on page 54.

Fig 8-1. Sensistor ISH2000 start screen.

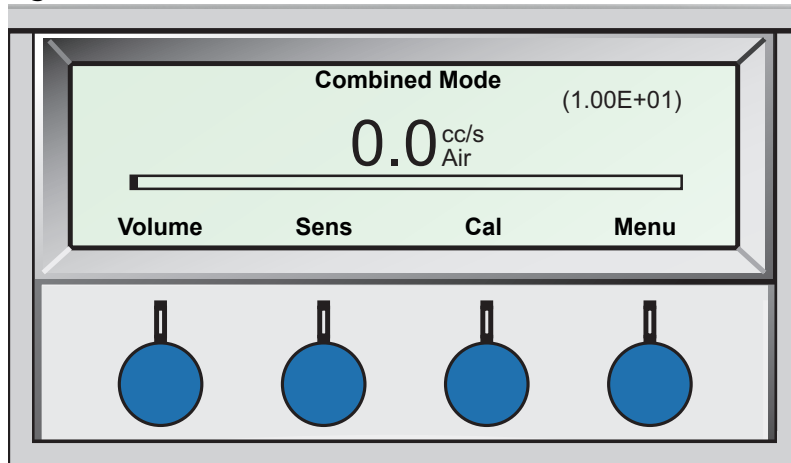

To enter the menus, press Menu (button 4).

Fig 8-2. Sensistor ISH2000 main menu screen

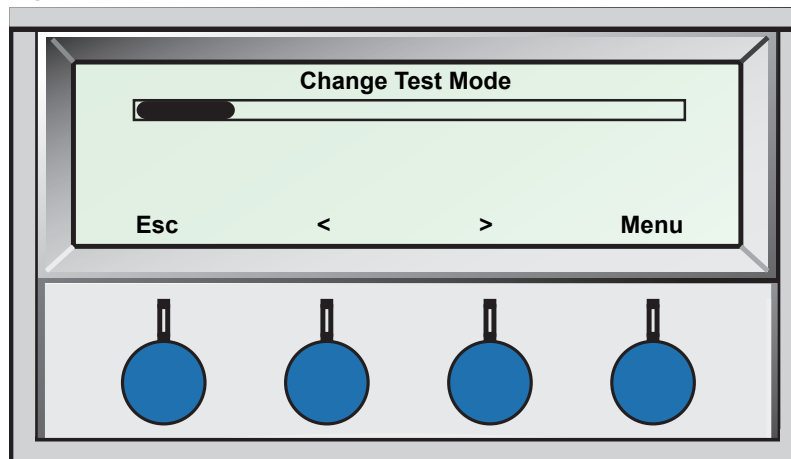

Press < and > (button 2 and button 3) to choose between main menus.

If no setting is made in a menu or its sub menu within 60 seconds, the instrument will revert to the Locating Mode/Measuring Mode.

For more information about the menu, see "Menu Overview" on page 54.

8.2 Button functions

The buttons may change functions in different menus. Always read the text, just above the buttons in the display, for the button functions.

All changes in values are valid only when saved using the Save or Enter button (button 4). All changes is saved into the instrument. Only *Trigg Level* is stored into the probe.

Use the Undo or Esc button (button 1) to delete a change in value and revert to the previous setting.

Use the Esc button (button 1) to browse backwards through the menus to the start position *Locating Mode/Measuring Mode*.

To change quickly from *Locating Mode* to *Measuring Mode* or vice versa, press button 4 three times in succession.

8.3 Stored values and setups

All values and instrument setups is saved into the instruments memory. Only the *Trigg Level* is stored into the hand probes memory. That mean that you easily can change the probe to another one and still keep your setup.

8.4 Engineering format

Some of the parameters of the detector are written in engineering format. This format can represent a very wide range of numbers from very small to very large numbers.

The following examples describes the format used in the detector:

$$1.00E+01 = 1.00 \times 10^1 = 10$$

$$1.00E+00 = 1.00 \times 10^0 = 1$$

$$1.25E-02 = 1.25 \times 10^{-2} = 0.0125$$

8.5 Change Test Mode

Choose the test method you will use in the menu *Change Test Mode*. There are three different methods to choose:

- Measuring Mode
 - Locating Mode
 - Combined Mode*
- * Not in ILS500 Mode

See Reference section for a description of the functions.

8.6 Calibration

Calibrate

The instrument must be calibrated by using the integral calibration function to ensure it displays the correct values in *Measuring Mode/Combined Mode*. After calibration the instrument will show the correct measured values on the display.

If the probe is replaced with another probe a new calibration must be performed.

Sensitivity too low for reject level

The Detector will warn if sensitivity of sensor is too low to safely detect a leak equal to the set *Reject Level* limit. The warning can be ignored and calibration updated and the CAL_CONF output will be set.

High signal! Check calibration leak/gas!

The Detector will warn if the calibration signal is unreasonably high. This can occur, for example, if 5% tracer gas mix has been used instead of proper Calibration gas or if the Calibration leak has an extra non-intentional leak. The warning can be ignored and the calibration updated and the CAL_CONF output will be set.

Sensor condition indicator

The indicator bar extends in length when the sensor is detecting Calibration gas. This indicator can be used for an early warning as to when a sensor replacement will be needed.

Fig 8-3. Sensor condition indicator.

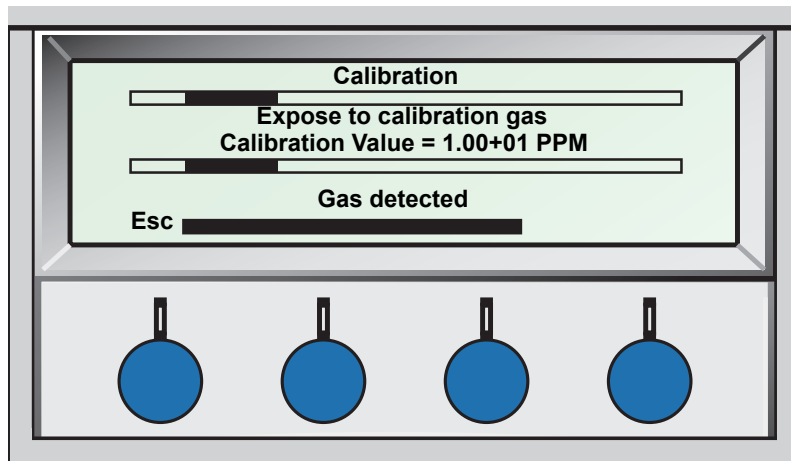

The length of the bar shows the condition of the sensor. The bar will become shorter if the sensor has lost some in sensitivity. The scaling of the indicator is not precise enough to say at exactly what length the sensor must be replaced. You will learn when this happens for your particular application. The instrument will also tell you in clear text when sensitivity is too low. See further in the next section below.

Calibration messages

Table 8-1. Different messages that can be displayed during calibration.

Message	Explanation	Action
Expose to background...	Prepare the probe for calibration.	Hold the probe in hydrogen free background.
Gas detected	Gas signal is detected. The probe has had enough gas exposure.	Remove the probe from the calibration gas or leak.
Calibration in progress Please Repeat again	Calibration was not within 10% of last.	Wait 30 s and calibrate again.
Calibration OK	Calibration was within acceptable limit.	Press Save (button 4) to store calibration in memory.

Message	Explanation	Action
No gas or unstable signal.	No gas signal or no stable signal detected during calibration.	Check if Calibration leak/gas valve is shut. Check that probe tip is not clogged.
	Signal when Calibration gas is shut off. Happens for Calibration gas only.	Check the calibrate gas valve.
	Background is higher than Calibration gas concentration.	Improve ventilation
Sensitivity too low for Reject level	Sensitivity of sensor is too low to guarantee correct response to a gas flow or concentration equal to the Reject level. The most likely reason is that sensor is too old.	Check Calibration leak/gas. Gas valve may be shut. Check that probe tip is not clogged. Check setting of Reject Level. Replace sensor if problem remains.
High signal! Check Calibration leak/gas!	Calibration leak/gas signal is abnormally high.	Check that Calibration gas mix is not replaced with tracer gas mix. Check condition of Calibration leak. Check that Calibration leak connections has no leaks.

Note: If calibration fails you can still use the instrument. Last valid calibration parameters will be used. You should, however, check that the instrument reacts to the Calibration leak/gas.

Calibration Value

Your Calibration should have a concentration or flow equal to or slightly above what you want to measure. See the examples below for specific recommendations.

Example for Calibration gas:

- *Reject Level* is set at 8 ppm
- For good accuracy, use a Calibration gas between 5-80 ppm hydrogen.
- 8 ppm hydrogen in synthetic air will give best results.

Example for Calibration leak

- *Reject Level* is set at 2.0E-4 atm. cc/s
- For best accuracy use Calibration leak within 2.0E-4 - 2.0E-3 atm cc/s.
- A Calibration leak calibrated to 2.0E-4 atm. cc/s will give best accuracy.

Calibration Unit

The *Calibration Unit* is set in the *Calibration* menu. Select ppm, cc/s, cc/min, SCCM, g/yr, oz/yr, mbarl/s, mm³/s, mm³/min, Pa m³/s or Custom. When you select Custom you can enter any unit as long as it contains a maximum of 12 characters.

Calibration can be performed with:

- a known hydrogen concentration
- a known flow leak

The following characters can be used: Upper and lower case Roman letters, the numbers ü,ÿ, Å, Ä,Ö, å,ä,ö,%,/,(,),and - (dash).

Note: The space (" ") is not supported. The leak rate unit string will be cut short at the first space found. See "Engineering format" on page 23.

Leak Gas

Leak Gas is the gas the Calibration Leak is defined to.

Calibration Time

The *Calibration Time* decides how long time the detector looks for a Calibration signal before giving up. If the calibration is set to, for example, 6 seconds the detector will record the maximum signal during 6 seconds after that the operator (or external hardware) orders a calibration.

It is very important that all delays in gas exposure as well as reaction time of sensor are taken into consideration when setting the calibration time. Calibration will not be correct if the maximum signal comes after that the calibration time has terminated.

This is also the timeout of the Calibration line in an APC program.

Interval

Calibration is a natural part of leak measurement and an important factor in quality assurance. It is impossible to specify an exact requirement for the interval between the calibrations because the applications for which the instrument is used can vary considerably.

There will be some oxidation of the probe sensor, which reduces the sensitivity, if the probe sensor:

- is not subjected to gas for a lengthy period or
- is exposed to a very small gas concentration (less than 10 ppm) with long intervals between exposure.

If the instrument is subjected to a very large gas concentration over a long period, a certain amount of insensitivity can occur directly afterwards. This saturation can make it difficult to detect very small leaks. Therefore, make it a habit of removing the probe from the measuring point as soon as the measured value is displayed. This gives the detector an opportunity to recover.

In the menu *Calibration/Interval* there is a setting where it is possible to set a reminder to calibrate the instrument. The interval can be set between 1 min to over 100 days. When it is time to calibrate, the instrument will signal with the text *Calibrate!* in the display together with sound. If the interval time is set to 0, the reminder function is switched off.

Function Calibration Interval can be used to remind the operator to perform a calibration.

Password Protected Calibration

If desired, the calibration can be set under the general password to prevent the operator from calibrating by mistake. In this case you will have to enter the password to start the calibration routine. Setting password protection on calibration is done in the *General Settings* menu. Note that you must also set a password. The instrument is delivered with no password set.

8.7 Locating Mode Settings

In *Locating Mode*, the signal is displayed in the form of a bar. The length of the bar varies with the gas concentration.

To Detect Leaks

If all you wish to do is to detect the presence of a leak, that is, to find out whether there is a leak or not, then use the Locating Mode. The definition of Leak/No Leak will be "A leak is a leak when it can be detected by the detector, set to a specific sensitivity".

To set up:

The operation in Locating Mode is not quantitative. No figures are given but the signal is still increasing and decreasing with gas concentration. Therefore, there is no actual calibration to be done, but rather a setting of the sensitivity to a desired level.

A typical set-up procedure for the Locating Mode is:

- Set up a Calibration leak which corresponds to the smallest leak you wish to detect.
- Put the probe close to the Calibration leak and note approximately what reaction you get (no reaction, small, medium, high, full scale) within the first few seconds.
- Set the sensitivity. This can be done permanently under the menu *Locating Mode* or temporarily as a *Direct Sensitivity Setting* on the display (unless you have set this function to OFF under menu *Sensitivity Settings*. There is also an Auto ranging function which can be selected under the *Locating Mode Settings* menu.)

If the sensitivity is set very high, you may find the baseline annoyingly unsteady.

Note: If the Locating Mode is used and the alarm function is required to be activated at a particular calibrated level, then the unit must be calibrated. The reason for this is that the alarm is immediately based on the Measuring Mode when the Locating Mode is displayed, due to inaccuracies in the Locating Mode signal.

To Locate Leaks

Locating mode is semi-quantitative, that is, it gives an audio and visual signal which increases as a leak is approached (a higher gas concentration) and decreases as you move the probe away from the leak. It does not display figures.

In this mode of operation leaks can easily be detected using a sensitivity which can be preset. Leaks can be located very accurately, even when there are other leaks nearby.

If, for example, you are trying to locate a leak on a refrigerator condenser tubing and the tubing has a major leak, then you will get an audio signal as soon as the probe is placed close to the condenser tubing. When the probe is moved around

over the condenser, the signal will increase as the probe approaches the leak. If the signal goes off the scale, simply reduce the sensitivity setting to bring the signal within the scale. By working with the sensitivity setting in this way, you will be able to locate multiple leaks that are in close proximity to each other.

Do not expose the probe to more gas than is necessary, because it will slowly saturate with time. It is good practice to detect a leak, locate it, and immediately remove the probe to avoid saturation. The probe is not damaged by the exposure but it will recover more slowly. After excessive exposure it will be less sensitive for a short period of time.

Background Compensation

There is always some hydrogen gas in the background. In fresh air this is as low as 0.5 ppm (parts per million).

Sensistor ISH2000 actively adjusts itself to the background. This is done automatically at start-up and thereafter, it slowly adapts itself to slow variations in the background concentration. By adjusting slowly (minutes) it avoids mistaking an actual leak for an increased background and vice versa. Therefore, a sudden rise in background concentration will be detected. However, if the concentration remains constant it will be gradually canceled out over a period of several minutes.

For example, if the background concentration for some reason should suddenly rise to 10 ppm H₂, then the detector will give a corresponding signal which will very slowly decline to zero. If you thereafter expose the probe to a leak which gives rise to another 10 ppm H₂, then the detector will give essentially the same signal as if there were no background concentration.

Sensitivity

Sensitivity of audio signal and signal bar in *Locating Mode*.

Note: This does not affect the *Measuring Mode*.

Auto Range

Set this parameter to ON for auto ranging of sensitivity in *Locating Mode*. Sensitivity will decrease two steps if the signal reaches full scale. Sensitivity is restored to selected *Sensitivity* when signal returns to zero.

Direct Sensitivity Adjustment

Setting this parameter to OFF will remove the sensitivity adjustment from the *Locating Mode* display. Sensitivity can still be adjusted in the *Sensitivity Settings* menu after entering password (if set).

Note: The sensitivity setting only affects the *Locating Mode* and *Combined Mode*.

Audio Threshold

Makes it possible to mute the sound to a set level in *Locating Mode*. The level is in % of full *Locating* bar.

Reject Indication

Makes it possible to show the indication *Reject* in *Locating Mode*.

Audio Ready Pulse

This sets the standby sound to a silent or pulsating tone.

8.8 Measuring Mode Settings

In *Measuring Mode* the measured value is displayed in figures. The default unit is in cc/s but it is possible to choose other units, See "Default parameters" on page 46.

To Measure Leaks

The Measuring Mode is used for measuring the size of a leak (or the concentration of a gas sample). To be able to do this measurement and obtain correct values, the instrument must first be calibrated using the calibration function.

In the Measuring Mode the detector determines the gas concentration from the change, as the probe goes from being exposed to background to being exposed to a certain gas concentration. The detector does not continuously monitor the gas concentration but takes just one reading instead. Another suitable alternative name for this mode could be Sampling Mode. It is important to keep this in mind when using the detector in this mode.

In Measuring mode the probe should be moved directly from a background situation to the test point. The size of the leak in ppm, is shown on the display. The probe can and should be removed from the measuring point as the measured value remains on the display.

The period during which the measured value is displayed can be adjusted in the *Measuring Mode Settings* menu.

Reject Level

Threshold level for Reject decisions. When this level has passed Reject it will be indicated by audio and LED signals.

Note: The frequency of the acoustic signal in *Measuring Mode* is controlled by *Reject Level*. A signal equal to the *Reject Level* will always give the same audio frequency despite the actual signal strength.

Measuring Unit

The *Custom Measuring Unit* is the unit to be displayed during measurement.

The measured value will be automatically calculated for other flow units. For example, if you calibrate with cc/s and want the instrument to show cc/min, the displayed value is adjusted by a internal factor of 60.

If *PPM* or *Custom units* are selected there will not be an automatic conversion factor calculation. If a unit conversion is needed, the conversion factor must be calculated manually and inserted into the *Correlation Value* (under *General Settings*).

The *Correlation Value* is always set to 1 when the *PPM* or *Custom units* are selected, but is adjustable afterwards.

The *Measuring Unit* is a text string with a maximum of 12 characters.

The following letters can be used; Upper and lower case English letters, the numbers 0 to 9, Å, Ä, Ö, å, ä, ö, %, /, and -. Space (" ") is not supported. The string will be shortened after the first space found.

Displayed Gas

Displayed Gas is the unit shown on the display. If another gas is chosen, the measured value is automatically recalculated.

Note: When selecting different types of gas it is assumed that the same type of tracer are used in both calibration leak and test objects (typically 95% N₂ /5% H₂). The conversion of different types of gas assumes laminar flow in the leak, which is normal. The instrument displays the total flow of the tracer gas.

Multipoint Measuring

Summing up of the Measuring result. A fixed or moving number of measurements with a maximum 25 measurement points can be chosen. The instrument must be in *Measuring Mode* or *Combined Mode* for this function to be active. Standard probe button functions is not available when using *Multipoint Measuring*, only in *Locating Mode*.

To use Multipoint Measuring

If a fixed number of measurement points is used then measure according to the following steps:

1. Push the probe button to begin the first measurement.
2. Place the probe on the measurement point during the time the bar moves. The instrument registers the results.
3. You might need to wait until the next measurement. The instrument signals-*Wait*.
4. Repeat the procedure for the next measuring point.

When all measurements are made the sum of all leaks is shown. If the sum of all leaks is greater or the same as the *Reject Level* then REJECT is shown. If the sum of all leaks is under the *Reject Level* then ACCEPT is shown. And if the sum of all leaks is greater than *Reject Level* before all measurements are made then REJECT is shown.

Use < > to view individual measurements.

To begin a new measurement action or to stop a current measurement push the probe button and hold the button for a moment.

It is possible to measure or search in *Combined Mode* for a leak without registering the measurement. The measurement value registers only when the staple moves (*Multipoint Measuring Time*).

If a dynamic number of measurement points is selected then do the measurement in the following steps:

1. Push the probe button to begin the first measurement.
 2. Place the probe near the measurement point during the time the staples move (*Multipoint Measuring Time*).
 3. You might need to wait until the next measurement. The instrument signals-*Wait*.
 4. Repeat the procedure for the next measuring point.
 5. To sum up all the measurements, push and hold the probe button a short time.
-

Multipoint Measuring Time

Set the time for each measurement.

Min Presentation Time

Signal values in *Measuring Mode* will never be presented shorter than this time. Values are, however, always presented until the signal has recovered. The default value is 1 second, but values from 0 - 120 seconds can be used.

Display Threshold

Hides all measurements under a set % of *Reject Level*.

Audio Threshold

Instrument is silent under a set % of *Reject Level*.

Reject Indications

There are three choices of *Reject Level* indications except the LEDs indication:

- Flashing screen
 - Chopped audio signal
 - Combination of indication 1 and 2.
-

Show Reject Level

Shows the *Reject Level* value on the display.

Audio Ready Pulse

This sets the standby sound to a silent or pulsating tone.

8.9 APC Settings*

APC is an abbreviation for Active Probe Control. APC is used to control an active probe via the Probe Control Port. There are several active probes available. Choose correct probe under the menu *Probe Type*. Customized APC drivers can be downloaded from a PC.

There is a possibility to adapt how to measure by adjusting the timers and *Purge Level*.

* Not in Battery Mode

Probe Type

Select the connected probe. When a custom driver is downloaded, it will replace "*No driver installed*".

APC Time A-D

Adjustable timer used by the APC system. APC timer can be used for general purposes in a custom APC program.

Purge Level

Standard probes that support active sampling use the *Purge Level* for fast interruption of sampling.

Setting *Purge Level* equal to, or just above, *Reject Level* will give the fastest possible cycle times for those probes.

Quick purging also enhances signal repeatability.

Note: Purge level interrupts active sampling of APC probes. This means that higher signals will be underestimated as the sensor is purged before full signal has developed.

Reset Signal

Reset the sensor signal in Measuring mode and Locating mode.

8.10 Display Settings

This section describes the different display settings of the Sensistor ISH2000.

Contrast

Contrast level of display. Higher value gives higher contrast. The contrast may need adjustment if ambient temperature changes.

Brightness

Brightness of the display lamp.

Invert Colors

Change the black to white and white to black. Useful in a dark environment to keep a high readability.

Screen Save Timeout

Display lamp will turn off if instrument is left idle for the number of minutes set by this parameter. The screen save timeout can be set between 1 and 60 minutes, the function is deactivated if set to OFF. The display lamp will return to the set brightness if any of the display or probe buttons are pressed, if a gas signal is detected or an instrument error is detected.

8.11 General Settings

This part describes the general settings of the Sensistor ISH2000.

Correlation Value

Correlation Value is used when it is necessary to correct the relation between the detector signal and the displayed number. This might be necessary if the hydrogen concentration of the Tracer Gas, inserted into the test object is changed, e.g. when the Tracer Gas is mixed with existing air in the test object

Language

The Sensistor ISH2000 user interface contains the following languages:

- English
 - French
 - German
 - Italian
 - Spanish
 - Swedish
-

Measure/Print Button

Setting this parameter to ON displays *Measure* or *Print* above the button 1. *Measure* will be displayed for an APC-Probe or *Print* for a Hand Probe. Pressing Measure will initiate a sample cycle. Pressing Print will send the values from the hand probe measurement to the printer port.

Probe Button

This is for setting the different functions with the probe button. These functions are as follows:

- Toggle Mode-makes it possible to switch between Measuring mode and Locating mode.
- Zero Locating signal in Locating mode.
- Measure/Print- makes it possible to initiate sample cycles or send the values from the hand probe measurement to the printer port.
- Probe Lamp- makes it possible to turn on and off the Probe Lamp.

Probe Lamp

Makes it possible to have the Probe Lamp ON even if the other Probe Button function is chosen.

Change Password

The user password is a text string (max 12 alphanumeric characters) used to lock critical parameters. Setting password to an empty string (no characters) means that no password is needed to modify the critical parameters. The default is no password ("").

Contact INFICON AB if you have lost your user password. If the *Password Protected Calibration* parameter is set to ON you will be prompted for a password when starting a calibration.

Note: Setting *Password Protected Calibration* to ON has no effect if no password is set.

Note: APC controlled calibration can be started from the bus in both cases.

Password Protection Level

Password Protection Level sets the protection level.

Standard is used when the main parameters shall be protected. High is used to protect all settings, such as sound and display properties.

Description of the different Password Protection Level

Password protected settings/ functions	Non (No password has been set)	Standard	Standard + Password Protected Calibration	High	High + Password Protected Calibration
Change Test Mode				Yes	Yes
Calibration (function)			Yes		Yes

Password protected settings/ functions	Non (No password has been set)	Standard	Standard + Password Protected Calibration	High	High + Password Protected Calibration
Calibration (settings)		Yes	Yes	Yes	Yes
Locating Mode Settings				Yes	Yes
Measuring Mode Settings		Yes	Yes	Yes	Yes
Display Settings				Yes	Yes
General Settings		Yes	Yes	Yes	Yes
Service Settings*	Yes	Yes	Yes	Yes	Yes

* For password to access *Service Setting*, please contact INFICON.

Audio Base Frequency

This sets the lowest audio base frequency tone in Measuring and Locating Mode.

Set Clock

Real time set as hh:mm:ss. Hours and minutes can be adjusted. Seconds will automatically be set to 00 when hours and minutes have been set. Clock runs even when detector is disconnected from the power supply.

Set Date

Real time clock date set as YY-MM-DD. Clock runs even when detector is disconnected from the power supply.

Data Output*

The Sensistor ISH2000 is equipped with a serial (RS232) printer port for data output. See "Printer port" on page 39.

* Not in ILS500 Mode

Info

Contains information about software versions, Serial number, and Internet contact information.

8.12 Service Settings

Service Settings contains important settings that the customer should not change without supervisor guidance. To enter *Service Settings* menu a password is required. Contact your local supplier for help.

Show Password

Shows the chosen password in case the customer has forgotten the password. Contact INFICON AB to have the code sent to you. See the web address under the section-Info.

Instrument System Reset

Resets all parameters to default settings. Contact INFICON AB to have the code sent to you. See the web address under the section-Info.

Detector Signal Level

The *Detector Signal Level* is the level which the sensor is considered to have recovered from the last gas signal. It decides when the DET_SIGNAL output will come on. this signal can be used to block the start of a calibration or new test cycle in semi and fully automatic testers.

IF DET_SIGNAL is high then this means that the sensor has detected hydrogen and has not yet recovered.

Detector Signal Level can be adjusted in the *Service Settings menu*. You can increase *Detector Signal Level* if you have many small disturbing signals. A high setting of *Detector Signal Level* gives better tolerance to "noise" gas signals at the expense of accuracy. A low setting gives best accuracy but lower tolerance for "noise" gas signals. The *Detector Signal Level* is set as 1 to 100% of the *Reject Level*.

Note: Increasing the *Detector Signal Level* may give poorer accuracy.

Trigg Level

Upper Limit setting for Peak hold in Measuring Mode.

Min Calibration Time

Lower limit setting for the timer which is used during calibration. Contact INFICON AB to have the code sent to you. See the web address under section-Info.

Calibration Tolerance

The maximum difference between the different calibration measurements to approve a calibration.

Battery Mode

Selection of battery power. Only used to adapt software for the battery model.

ILS500 Mode

This mode is used to adapt the ISH2000 for use into Leak Detector System ILS500. Combine Mode and Printer Port is not available when ILS500 Mode is active. ISH2000 always start in Measuring Mode at startup.

Number of Significant Digits

Setting of significant numbers in *Measuring* and *Combined Mode*. It is used when a more exact measurement is needed. A good control of the environment and

calibration is required to be useful. Contact INFICON AB to have the code sent to you. See the web address under section-Info.

Debug Mode

This mode is used during service and software development.

Service Mode

This mode contains useful information to analyze the gas sensor behavior and the APC I/O's and timers.

8.13 Combined Mode

In *Combined Mode* the bar and the sound in *Locating Mode* is combined with the figures in *Measuring Mode*.

The loud speaker sound follows the *Locating Mode* signal.

Note: After a system reset the default mode is *Combined Mode*.

When you have located the leak then you can measure its size in the following way:

1. Remove the probe from the leak.
 2. Wait until 0.0 appears on the display
 3. Then put the tip of the probe on the leak.
-

8.14 Probe

The Hand Probe P50 is a non-sniffing probe. Gas Measuring takes place in a sensor that is in the tip of the probe. The probe is equipped with a function button, indicator lamps, and lighting. The probe can be ordered with a flexible neck.

During operation the heat of the probe tip is 50°C

Note: There are a variety of different probes that can be connected to the Sensistor ISH2000. When using an active probe please refer to the respective probe manual.

Changing the Probe

After attaching a probe the Sensistor ISH2000 needs to stabilize, and the green LED should blink. If it does not, then there is a fault in the cable or the hydrogen sensor inside the probe is faulty.

When the stabilization period is over the green LED should stay on. Before using the Sensistor ISH2000 the instrument needs to be calibrated. Repeat calibration after one hour to achieve greatest accuracy.

Changing the Probe Tip

The probe tip (sensor for P50) is replaceable and is locked with a union nut. The union nut seals against contact with moisture. If you are not sure about changing the probe tip then we recommend that you send it to an authorized service center.

To change the probe tip do the following steps:

1. Turn off the instrument.
2. Loosen the safety nut with a 10 mm wrench.

3. Remove the union nut by hand. The o-ring in the union nut creates some friction.
4. Remove the probe tip by drawing it straight out.
5. Mount a new probe tip. Make sure it is in correct position.
6. Observe the contact area between the probe pipe and the probe neck. They should contact each other.
7. Refit the union nut.
8. Tighten with a 10 mm wrench.

8.15 Probe Control Port

The Sensistor ISH2000 is equipped with a parallel Probe Control port. This Probe control port can be used for controlling active probes, feeding status signals to a supervising computer system.



CAUTION!

The Probe Control Port (25-pin D-type) on the back of the instrument is not a computer or printer port. Connecting a printer or any other computer device may cause permanent damage to the connected device.

Note: Battery operated model Sensistor ISH2000C does not have a *Probe Control Port*.

Pin configuration for the different detector models is described under Model Specific Specifications below.

See "Sensistor ISH2000 specifications" on page 50 for electrical specifications.

See "Status signal patterns" on page 38 for signal patterns.

Probe Control Port Connector

The control port connector is a 25-pin female D-sub. Refer to Table 8-2 for the pin configuration.

Table 8-2. Pin configuration.

Pin	Type	Signal name
1	-	GND
2	-	GND
3	-	GND
4	IN	IN_0
5	IN	IN_1
6	IN	IN_2
7	IN	IN_3
8	IN	IN_4
9	OUT	CAL_CONF
10	OUT	OUT_6
11	-	GND

Pin	Type	Signal name
12	-	GND
13	-	GND
14	OUT	DET_ERROR
15	OUT	LEAK_OUT
16	OUT	DET_ON
17	OUT	DET_SIGNAL
18	OUT	DET_WAIT
19	OUT	OUT_0
20	OUT	OUT_1
21	OUT	OUT_2
22	OUT	OUT_3
23	OUT	OUT_4
24	OUT	OUT_5
25	OUT	24 VDC OUT

Status signal patterns

Table 8-3. Status signals for pin 14 - 18.

Signal	Function
DET_SIGNAL	Gas detected / Sensor not recovered.
DET_WAIT	High during warm-up.
DET_ON	High when detector is on.
LEAK_ALARM	Leak above Reject Level detected.
DET_ERROR	High if Probe, Sensor or Cable is broken.

DET_ERROR will go high for a short time (1-5 seconds) when the detector is switched on. It will go low when the sensor has been checked.

In normal operation, DET_ERROR = HIGH means that there is a problem with the sensor, probe, or cable.

DET_WAIT is high when instrument is in warm-up mode after switching on power. Instrument will also go into warm-up if there is a temporary fault in the sensor or sensor connection.

The timing of the status signals in relation to different events is described by the following two examples:

Example: Input signals issued to control the APC system should have a pulse length of at least 40 ms.

Example: Output signals switch with a cycle time of 100 ms (0.1 s). This is the cycle time of the APC system.

Note: Not valid for battery operated version of Sensistor ISH2000 (ISH2000C).

After power on

Fig 8-4. Status signals after power on.

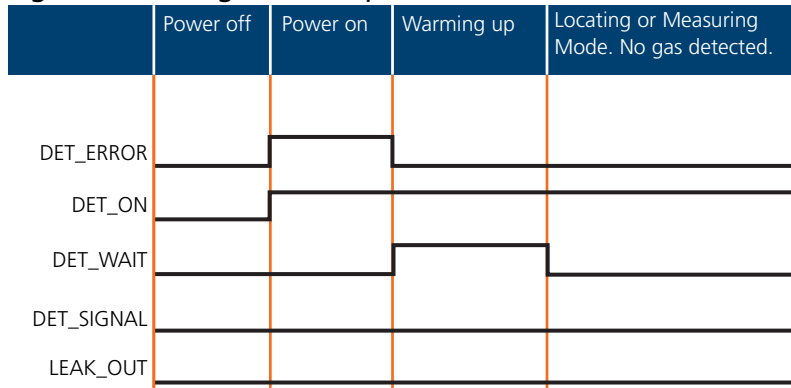

When detecting a gas signal

Fig 8-5. Status signals when detecting a gas signal.

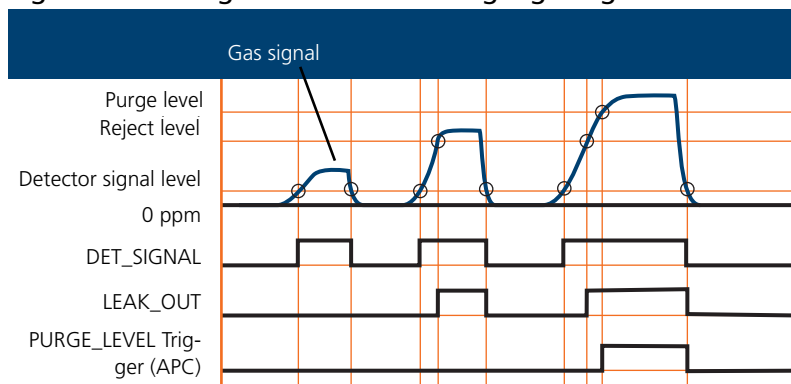

8.16 Printer port

The Sensistor ISH2000 is equipped with a serial printer port. This is the 9-pin D-type connector. It is used for printer connection, RS232 commands and APC driver installation.

NOTICE!

 Always switch power off before disconnecting or connecting any cable.

Connector pin configuration

The printer port is a standard 9-pin male D-sub. The connecting cable is a standard 9-pin file transfer cable (Null Modem Cable). For the pin configuration refer to Table 8-4.

Table 8-4. Pin configuration of the printer port.

Pin	Signal	Comments
1	(DCD)	Not used
2	RD	Received data
3	TD	Transmitted data
4	(DTR)	Not used

Pin	Signal	Comments
5	SG	Signal ground
6	(DSR)	Not used
7	(RTS)	Not used
8	(CTS)	Not used
9	+7 VDC	Power feed USB/RS232 converter

Only pin 2 (Received data), pin 3 (Transmitted data) and pin 5 (Signal ground) are used. Refer to Figure 8-5 for the wiring diagram.

Fig 8-6. D9 Null modem cable wiring diagram

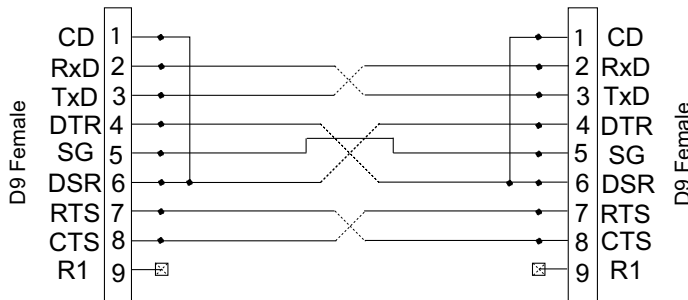

Selectable printer types

Most PC-printers with serial interface can be connected to the 9-pin printer port. Parallel (Centronics) interface printer can be used if connected through a serial to parallel converter.

The port can be set up for the following printer types: PC Printer and Data Dump.

No printer

Printer output disabled. Incoming communication is enabled. Sensistor ISH2000 listens for incoming data but will not print/send test results.

PC printer (with serial interface)

The *PC Printer* option can be used to print data on most standard PC printer with serial interface. Parallel interface printers can be used if connected through a serial to parallel converter (see below).

Note: The output format has been chosen to be as simple as possible to ensure that most printers will accept it. Therefore, the printer output does not use any flow control. This means that some printers may delay printing until the input buffer is full or a pre-defined timeout has elapsed.

Table 8-5. Communication specifications.

Setting	Value
Data rate	1200 baud
Data bits	8
Stop bits	1
Parity	None
Flow control	None

Note: Due to the large variety of printers available on the market, INFICON does not take responsibility for the operation of a particular type of printer.

Printed data

The detector can print the following information:

- 1 Date and Time for Power on of detector.
- 2 Time of print.
- 3 Value of all gas signals above the Reject Level.
- 4 Test result: "Accept" or "Reject".
- 5 Value of signal.
- 6 Result of calibration: "OK" or "Calibration Not saved", Date and Time, Parameter settings.

Printing of the current value can also be requested by an RS232 command or ordered manually by pressing *PRINT*.

Table 8-6. Probe type determines information printed.

Probe type	Data printed
Hand Probe P50	1, 2, 3, 4, 6
Counter Flow Hand Probe AP57	1, 2, 3, 4, 6
Sniffer Hand Probe AP55	1, 2, 4, 5, 6
Sampling Probe AP29 ECO	1, 2, 4, 5, 6

Measuring data output

The *Measuring Data Output* option is intended for transferring test results to a supervising computer system such as, for example, a PLC system.

Table 8-7. Communication specifications.

Setting	Value
Data rate	9600 baud
Data bits	8
Stop bits	1
Parity	None
Flow control	None

The data format for Measure data output consists of nine ASCII characters (ten if three significant digits are used). Seven characters (or eight if three significant digits are used) show the value in engineering format (See "Engineering format" on page 23). One character shows the result of the test, and one character shows the line feed (LF).

Table 8-8. The character indicating the result of the test is one of the following.

Character	Result of the test
A	Accept. Previous test was below Reject Level limit.
R	Reject. Previous test was above Reject Level limit.
P	Rejected by Purging. Previous test was above purge limit (and Reject level limit).
C	Calibration approved. Previous cycle was calibration. Calibration was approved.

Character	Result of the test
F	Calibration failed. Previous cycle was calibration.
E	Test interrupted by "Error" that occurred during cycle (probe or sensor error etc.).

Example: 2.5E-04R (LF)

This example is a line feed (LF), R means that the test was above the Reject Level limit, and the value was 2.5E-04.

For passive probes (for example P50, AP55 and AP57*) data is printed when a signal is detected above *Reject Level* or when the print button is pressed. Activate this under *Measure Button* menu.

For active probe AP29, data is printed at end of measurement sequence.

Printing of the current value can also be requested by an RS232 command or ordered manually by pressing *PRINT*. See "Connector pin configuration" on page 39.

* A custom APC program which sets the MEAS flag, will print as AP55/AP29 ECO and an APC program not using the MEAS flag prints as P50.

Locating data output

The *Locating Data Output* option is intended for automated scanning of weld seams etc.

Note: The *Locating Data* is expressed in arbitrary units. *Locating Mode* signal is not affected by calibration!

Table 8-9. Communication specifications.

Setting	Value
Data rate	9600 baud
Data bits	8
Stop bits	1
Parity	None
Flow control	None

The data format for Locating data output contains of nine ASCII characters. Eight characters show the value in engineering format (See "Engineering format" on page 23), and one character shows linefeed (LF).

The print time is 50Hz continuous streaming data.

RS232 serial communication

The most commonly used Sensistor ISH2000 functions can be started/configured over the RS232 interface.

Table 8-10. RS232 communication specifications.

Setting	No Printer	PC Printer	Data Output
Data rate	115200 baud	1200 baud	9600 baud
Data bits	8	8	8

Setting	No Printer	PC Printer	Data Output
Stop bits	1	1	1
Parity	None	None	None
Flow control	None	None	None

RS232 interface commands

Table 8-11. Common used functions.

Action Command	Header	Data
Calibration Request	K	None
Measure Request	M	None
Print Request	N	None
Stop Measurement	Q	None
Measuring Mode	X	None
Locating Mode	Z	None
Combined Mode	Y	None

K = Calibration request

Starts calibration if the Sensistor ISH2000 has an active probe driver installed. Sensistor ISH2000 answers with a "K" if an active driver containing a calibration routine was found and "F" if the calibration APC sequence not found. Calibration doesn't start if Purge level is reached.

M = Measure Request

The active test cycle defined by the APC driver starts. "M" is returned if the selected driver supports active test. "F" (failed) is returned otherwise.

N = Print Request

Returns current Measuring value.

Q = Set APC in stand by, (stop a measurement)

Returns a "Q".

X = Shift State to "Measuring Mode"

Returns nothing.

Z = Shift State to "Locating Mode"

Returns nothing.

Y = Shift State to "Combined Mode"

Return nothing.

Table 8-12. The following data/setups can be downloaded to Sensistor ISH2000.

Setup Command	Header	Data
Calibration Request text	CR	Custom Text string (max 35 characters) To return to the original text just leave the text string empty.

Setup Command	Header	Data
Calibration Fail text	CF	Custom Text string (max 35 characters) To return to the original text just leave the text string empty.
Reject Level	A	n.nnE+nn
Correlation Value	B	n.nnE+nn
Measuring Unit	C	Custom Text string (max 12 characters)
Measuring Unit	CUx	x=1 to 11 (1=ppm, 2=cc/s up to 11)
Leak Gas	LGx	x=1 to 13 (1=5%H2/95%N2, 2=Air up to 11**)
Displayed Gas	DGx	x=1 to 13 (1=5%H2/95%N2, 2=Air up to 11**)
Leak Gas	LG	Custom text string (max 12 characters)
Displayed Gas	DG	Custom text string (max 12 characters)
Probe Type	APx	x=1 to 9 (1=Hand Probe, 2=Custom Probe up to 9)
Timer A	D	nnn*
Timer B	E	nnn*
Timer C	F	nnn*
Timer D	G	nnn*
Purge Level	H	n.nnE+nn
Calibration Value	I	n.nnE+nn
Calibration Unit	J	Custom text string (max 12 characters)
Calibration Unit (Program settings)	JUx	x=1 to 8 (1=ppm, 2=CC/S up to 8)

* Entered as integer in 10's of seconds, 1= 0.1s, 100 = 10s, 60000= 6000s

** Gases: 95%N2/5%H2, Air, He, N2, H2, R134a, R22, R290, R404a, R407c, R410a, R600a, R1234yf.

Transfer of parameters

Send parameters one by one; first send the specific header (for example "A"), then send the data (for example "1.00E+01"). Data string must be ended with a carriage return character, chr13 (dec).

Example: "CPPM" or "C PPM", Carriage Return (chr 13).

Parameters can be sent in any order you like:

- If your data was received and correct, Sensistor ISH2000 immediately echoes (sends back) the data.
- If you send a non existing header you will not receive anything.
- If the data could not be converted in the Sensistor ISH2000 you will receive the string "CoEr", (Conversion Error).

Note: Remember to use capitals for the header.

APC driver installation

All standard APC drivers are installed in the detector.

Note: Battery operated model Sensistor ISH2000 does not incorporate the APC feature.

For custom APC driver design and installation contact support at INFICON.

8.17 Sensistor ISH2000P installation

The panel mount model can be installed in the operator's panel or any other flat surface of your leak tester. Mounting brackets and panel rubber seal are delivered with the detector. Refer to Figure 8-6.



CAUTION!

The detector should preferably be mounted on a vertical surface. Tilting more than 30 degrees is not recommended. Tilting more makes air circulation poor resulting in increased temperature inside detector. This will reduce contrast of display and lifetime of lamp and electronic circuits.



NOTICE!

After installation verify that ambient temperature is below 50°C.

Fig 8-7. Panel cut out dimensions.

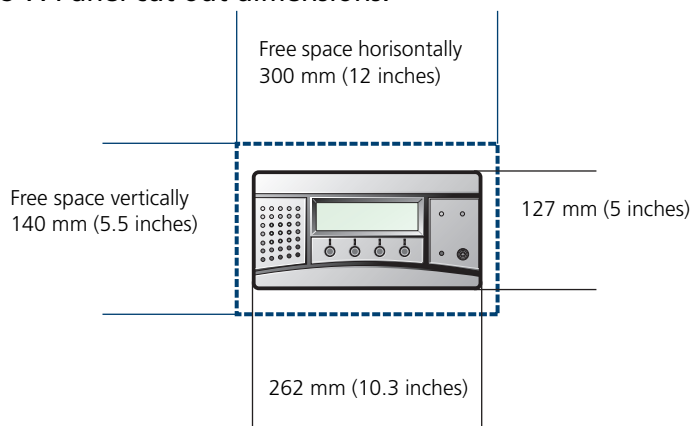

Measurements:

- Panel cut out: 262 x 127 mm (5 x 10.3 inches).
- Maximum panel thickness: 8 mm (0.3 inch).
- Allow an extra 20 mm (0.8 inch) on left and right side for mounting brackets. Depth of open space in panel is at least 15 cm (6 inches) for Sensistor ISH2000 to fit.

Installation process

Table 8-13. Install the detector as follows

Step	Action
1.	Cut hole in panel according to figure above, and remove burrs.
2.	Check that rubber o-ring is in correct position in the groove around the edge of the detector.
3.	Put the detector in place in the panel hole.
4.	Hold the panel in place while fixing the mounting brackets to the detector (See Figure 8-7).
5.	Align the detector horizontally and lock it by tightening the 4 set screws.
6.	Lock the set screws with the locking nuts.
7.	Connect ground terminal to protective ground of cabinet.

Fig 8-8. Fixing the mounting brackets.

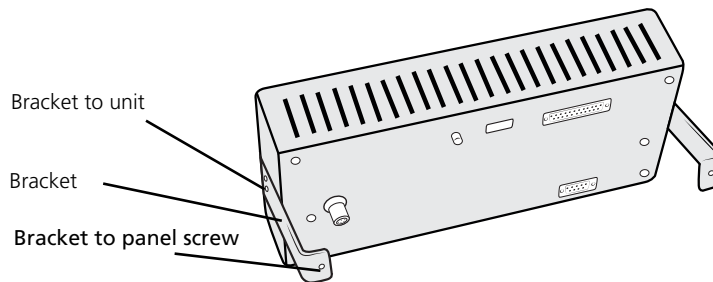

See "Sensistor ISH2000 specifications" on page 50 for electrical connections

8.18 Default parameters

Table 8-14. Range and default settings of all Sensistor ISH2000 parameters.

Parameter	Range	Default
APC Time A	0.0 - 6000.0 s	10.0 s
APC Time B	0.0 - 6000.0 s	0 s
APC Time C	0.0 - 6000.0 s	0 s
APC Time D	0.0 - 6000.0 s	0 s
Audio Base Frequency	Several Choices	400 HZ
Auto Range	ON/OFF	ON
Audio Ready Pulse	ON/OFF	ON
Audio Threshold (Locating)	0 - 100%	0%
Audio Threshold (Measuring Mode)	0 - 100%	0%

Parameter	Range	Default
Battery mode	ON/OFF	OFF
Brightness	0 - 21	21
Calibration Time	Min Calibra. Time-30 s	8 s
Calibration Tolerance	0-100%	10%
Calibration Unit	Several Choices	cc/s
Calibration Value	1.00E-37 - 1.00E+37	1.00E+01
Contrast	0-20	10
Correlation Values	1.00E-37 - 1.00E+37	1.00E+00
Data Output		No Data Output
Debug Mode	ON/OFF	OFF
Detector Signal Level	0 - 100%	20%
Direct sensitivity adjustment	ON/OFF	ON
Display Threshold	0 - 100%	0%
Displayed Gas	Several Choices	95%N2/5%H2
ILS500 Mode	ON/OFF	OFF
Interval	0 - 255	Days/Hours/Minutes
Invert Colors	ON/OFF	OFF
Language	Several choices	English
Leak Gas	Several Choices	H2N2
Measure/Print Button	ON/OFF	OFF
Measuring Unit	Several Choices	cc/s
Menu Mode	Several Choices	Combined Mode
Min Calibration Time	0 - 30 s	5 s
Min Presentation Time	120 s	1 s
Multipoint Measuring	Several Choices	OFF
Multipoint Measuring Time	0.0 - 30.0 s	5.0 s
Number of significant Digits	2/3	2
Password	Max 12 characters	"" = No password
Password protected calibration	ON/OFF	OFF
Password Protection Level	Standard/High	Standard
Probe Button	Several Choices	No Function
Probe Lamp	ON/OFF	OFF
Probe Type	Several Choices	Hand Probe
Purge Level	1.00E-37 - 1.00E+37	1.00E+02

Parameter	Range	Default
Reject Indicator (Locating Mode)	ON/OFF	ON
Purge Level	1.00E-37 - 1.00E+37	1.00E+02
Reject Indication (Locating)	ON/OFF	ON
Reject Indication (Measuring)	ON/OFF	OFF OFF
Reject Level	1.00-E-37 - 1.00E+37	1.00E+01
Screen Save Timeout	1 - 60 min	20 min
Sensitivity	1 - 15	8
Set Clock	hh:mm:ss	-
Set Date	YY-MM-DD	-
Show Reject Level	ON/OFF	ON
Trigg Level	1.00E-37 - 1.00E+37	0.00E+00

9 Trouble-shooting

In case of trouble using the Sensistor ISH2000, try to solve the problem with these simple trouble-shooting guidelines. If the measures described below do not result in a functioning instrument, send or hand in the instrument to an authorized service workshop for repair. See "Support by INFICON" on page 53.



WARNING!

Opening or dismantling a Sensistor ISH2000 that is powered up can cause serious personal injury or danger to life. The instrument contains no parts that can be repaired by the user and may only be dismantled by an authorised service technician.

Table 9-1. Fault symptoms and measures.

Fault symptoms	Measures
No sound in Locating Mode and Measuring Mode.	Press the + button repeatedly.
No picture on display, no sound.	Check the fuse.
No picture but only sound when exposed to gas.	Display setting may be wrong. Watch the display from the side at a low angle and aim a lamp at the screen. Try to see the text so that you can enter the Display Settings menu and adjust contrast and brightness. If this doesn't help - send in the instrument for replacement of display lamp.

Table 9-2. Error messages and measures.

Error messages	Measure OBS
Check Probe and Cable. Red LED flashes quickly.	Check that the probe cable is properly connected to the probe and the instrument. If the fault persists, replace the probe/cable.
Error + (Probe Type)	Error in Active Probe. See Probe Manual.
Check Sensor, Voltage Error	Check that the sensor is properly connected to the probe. If the fault persists, replace the sensor.
Check Sensor, Temp.	Check that the sensor is properly connected to the probe. If the fault persists, replace the sensor.
Probe not upgraded	Upgrade probe to latest version

10 Sensistor ISH2000 specifications

Table 10-1. Power supply specifications.

Power	Sensistor ISH2000	Sensistor ISH2000C	Sensistor ISH2000P
AC mains voltage	100-240 V 50/60Hz.	100-240 V 50/60 Hz	-
AC mains current	Typically 1 A (2 A pulse at power on).	Typically 300 mA	-
Fuse	2 A slow/ 250 VAC.		-
Nominal battery voltage	-	16.1 VDC	-
Operating time	-	h without screen saver, at 20 C.	-
Charging time	-	6.5 h	-
Power supply voltage	-	-	24 VDC
Power supply current	-	-	3 A max.

Table 10-2. Input and output connections.

Input/output	Sensistor ISH2000	Sensistor ISH2000C	Sensistor ISH2000P
Power input connector	AC input connector, IES 320.	Charger input connector, 2.1 x 5.5 mm std. Positive centre.	4 pin Phoenix MC 1.5/ 5.81 Series Detachable screw terminal.
Probe control/Status port	25-pin D-sub female.	-	25-pin D-sub female.
Minimum pulse length	40 ms	-	40 ms
Input impedance	50k ohm	-	50k ohm
Input maximum range	-34 to +38 VDC	-	-34 to +38 VDC
Input high	> 12.0 VDC	-	> 12.0 VDC
Input low	< 8.0 VDC	-	< 8.0 VDC
Output current	max 0.5 A/output, max 2.5 A total	-	max 0.5 A/output, max 2.5 A total
Inductive loads	External clamp diodes recommended	-	External clamp diodes recommended
Low state voltage	Max 1.5 VDC	-	Max 1.5 VDC
Low state leakage current	Max 100 μ A	-	Max 100 μ A
Short circuit protection	Thermal and electronic	-	Thermal and electronic

Input/output	Sensistor ISH2000	Sensistor ISH2000C	Sensistor ISH2000P
Output high	22-24 VDC	-	> (Supply voltage - 2.5 VDC)
Output low	< 1.5 VDC	-	< 1.5 VDC
Serial communication port connector	9-pol D-sub male	9-pol D-sub male	9-pol D-sub male
Serial communication port standard	RS232	RS232	RS232

Table 10-3. Miscellaneous specifications.

Misc.	Sensistor ISH2000	Sensistor ISH2000C	Sensistor ISH2000P
Protection (IEC529)	IP64 (front), IP32 (back)	IP63 (in carrying case)	IP64 (front), IP32 (back)
Net weight	3.9 kg (8.6 lb)	4.0 kg (8.8 lb) 4.9 kg (10.8) incl. case, probe and charger	1.8 kg (4.0 lb)
Overall dimensions	275 x 155 x 170 mm (11 x 6 x 7 inches)	275 x 190 x 170 mm (11 x 7 x 7 inches)	275 x 140 x 75 mm (11 x 6 x 3 inches)
Environment temperature	0-50°C	0-50°C	0-50°C
Environment humidity	10-90% RH	10-90% RH	10-90% RH

Table 10-4. Gas sensing specification (In Locating Mode)

Selected unit	Sensitivity
mbarl/s air (using 5% H ₂ /95% N ₂ as Tracer Gas)	1 x 10 ⁻⁷ mbarl/s
g/yr R143a (using 5% H ₂ /95% N ₂ as Tracer Gas)	0.02 g/yr

Table 10-5. Gas sensing specification (In Measuring Mode)

Selected unit	Sensitivity	Measurement range	Linearity	Repeatability
ppm (H ₂)	0.5 ppm	0.5 - 2000 ppm (0.2%)	Typ. ± 15% of reading (within 0.1 - 10 x calibration point in range 0.5 - 100 ppm)	Typ. ± (10% of reading + 0.3 ppm)
mbarl/s air (using 5% H ₂ /95% N ₂ as Tracer Gas)	5 x 10 ⁻⁷ mbarl/s	5 x 10 ⁻⁷ - 4 x 10 ⁻² mbarl/s	Typ. ± 15% of reading (within 0.1 - 10 x calibration point in range 1 x 10 ⁻⁵ - 2 x 10 ⁻³ mbarl/s)	Typ. ± (10% of reading + 3 x 10 ⁻⁷ mbarl/s)
g/yr R143a (using 5% H ₂ /95% N ₂ as Tracer Gas)	0.2 g/yr	0.2 - 8300 g/yr	Typ. ± 15% of reading (within 0.1 - 10 x calibration point in range 0.2 - 420 g/yr)	Typ. ± (10% of reading + 0.1 g/yr)

11 Spare parts and accessories

There are a variety of spare parts and accessories to the Sensistor ISH2000. In the following table some of these are presented, for a complete list of all spare parts and accessories please visit www.inficon.com.

Table 11-1. Spare parts and accessories.

Part	Part no.
Hand Probe P50	590-780
Hand Probe P50-FLEX	590-790
Probe Cable C21 Length 3m	590-161
Length 6m	590-175
Length 9m	590-165
Length 4m (Helical)	590-163
Length 6m (Helical)	590-164
Probe Tip Protection Cap for Hand Probes P50 and P50-FLEX	590-625 (Set of 500) 591-273 (Set of 50)
Probe Tip Filter	591-234 (Set of 50)
Power cable eu	591-146
Power cable uk	591-147
Power cable us	591-853
Fuse, 2 A slow for Sensistor ISH2000	591-578
Carrying case for Sensistor ISH2000C	591-329
Battery charger for Sensistor ISH2000C	591-795
Hand Probe sensor	590-292
Mounting kit Sensistor ISH2000P	590-810
Phoenix connector to Sensistor ISH2000P	591-792
O-ring seal	591-528
Calibration Leaks. Standard or customer specific leaks for detector calibration	see separate Data Sheet

12 Support by INFICON

12.1 How To Contact INFICON

For Sales and Customer Service contact nearest INFICON Service Center. The address is found on the website: www.inficon.com

If you are experiencing a problem with your instrument, please have the following information readily available:

- The serial number and firmware version for your instrument,
- A description of your problem,
- An explanation of any corrective action that you may have already attempted, and the exact wording of any error messages that you may have received.

12.2 Returning your instrument to INFICON

Please use the Product Return Form which was included with the product at delivery.

Do not return any component of your instrument to INFICON without first speaking with a Customer Support Representative. You must obtain a Return Material Authorization (RMA) number from the Customer Support Representative.

If you deliver a package to INFICON without an RMA number, your package will be held and you will be contacted. This will result in delays in servicing your instrument.

Prior to being given an RMA number, you may be required to complete a Declaration Of Contamination (DOC) form if your instrument has been exposed to process materials. DOC forms must be approved by INFICON before an RMA number is issued. INFICON may require that the instrument be sent to a designated decontamination facility, not to the factory.

13 Menu Overview

EN

Volume		
Sens		
Cal		
Menu	Change Test Mode	Measuring Mode Locating Mode Combined Mode ¹⁾
	Calibration	Calibrate Calibration Value Calibration Unit Leak Gas Calibration Time Interval Password Protected Calibration
	Locating Mode Settings	Sensitivity Auto Range Direct Sensitivity Adjustment Audio Threshold Reject Indication Audio Ready Pulse
	Measuring Mode Settings	Reject Level Measuring Unit Displayed Gas Multipoint Measuring Multipoint Measuring Time Min Presentation Time Display Threshold Audio Threshold Reject Indications Show Reject Level Audio Ready Pulse
	APC Settings ²⁾	Probe Type ²⁾ APC Time A ²⁾ APC Time B ²⁾ APC Time C ²⁾

Volume Sens Cal Menu		APC Time D ²⁾
		Purge Level ²⁾
		Reset Signal ²⁾
	Display Settings	Contrast
		Brightness
		Invert Colors
		Screen Save Timeout
	General Settings	Correlation Value
		Language
		Measure/Print Button
		Probe Button
		Probe Lamp
		Change Password
		Password Protection Level
		Audio Base Frequency
		Set Clock
		Set Date
		Data Output ¹⁾
		Info
		Service Settings
	Instrument System Reset	
	Detector Signal Level	
	Trigg Level	
	Min Calibration Time	
	Calibration Tolerance	
	Battery Mode	
	ILS500 Mode	
	Number of Significant Digits	
	Debug Mode	
	Service Mode	

¹⁾ Not in ILS500 Mode

²⁾ Not in Battery Mode

14 Declaration of conformity



Declaration of Conformity

Manufacturer

INFICON AB
Westmansgatan 49
SE-582 16 Linköping
Sweden

Phone: +46 (0)13-355900
Fax: +46 (0)13-355901

Product

Hydrogen Leak Detector

Brand Names

ISH 2000	(Table top model)
ISH 2000 C	(Battery operated model)
ISH 2000 P	(Panel mounted model)
ISH 2000 ICE	(Table top model)
ISH 2000 C ICE	(Battery operated model)

The manufacturer declares the above products to be produced in conformity with the following directives

CE Marking Directive (93/68/EEC)
EMC Electromagnetic Compatibility (2004/108/EC).
LVD Electrical safety - Low Voltage (2006/95/EC)*.
WEEE Waste electrical and electronic equipment (2002/96/EC).
RoHS Restriction of the use of certain hazardous substances in electrical and electronic equipment (2002/95/EC)

* Relevant only for battery charger (CE marked) on the Battery operated model.
Manufacturers declaration provided on request.

For INFICON AB, September 01, 2011

Fredrik Enquist / R&D Manager

INFICON AB

Box 76, SE-581 02 Linköping, Sweden
Phone: +46 (0) 13 35 59 00 Fax: +46 (0) 13 35 59 01
www.inficon.com E-mail: reach.sweden@inficon.com

15 Recycling



Disposal of product when taken out of service

According to EU legislation, this product must be recovered for separation of materials and may not be disposed of as unsorted municipal waste.

If you wish you can return this INFICON AB product to the manufacturer for recovery.

The manufacturer has the right to refuse taking back products that are inadequately packaged and thereby presents safety and/or health risks to the staff.

The manufacturer will not reimburse you for the shipping cost.

Shipping address:
INFICON AB
Westmansgatan 49
582 16 LINKÖPING´
SWEDEN



INFICON AB, Box 76, SE-581 02 Linköping, Sweden
Phone: +46 (0) 13 35 59 00 Fax: +46 (0) 13 35 59 01
www.inficon.com E-mail: reach.sweden@inficon.com