



EN

PLASTER TECHNOLOGY

www.hama-equipment.com

HAMA Duo Power 2.0 Plastering Machine & Airless



USER MANUAL
INCLUDING SPARE PARTS LISTS



READ THIS MANUAL BEFORE USING THIS MACHINE

HAMA
Handelsstraat 36 b
7482GW Haaksbergen
The Netherlands

☎ +31 (0)53 303 12 60
@ info@hama-equipment.com
🌐 www.hama-equipment.com

Copyright ©

All rights reserved. No part of this publication may be copied, stored in a data file or made public, in any way or form, be it electronic, mechanical, by means of photocopies, recording or by any other method, without written permission in advance from HAMA.

Changes

This publication is based on the most recent information available at the time of publication. Because HAMA pursues a policy of continuous product improvement, this publication may be changed without prior notice.

Liability

This publication has been prepared with the greatest possible care. Nevertheless, it may not be entirely accurate. HAMA accepts no liability for any errors in this publication or the possible consequences thereof.

HAMA is a registered trademark of Modulen & Engineering Menzing B.V. established in Haaksbergen (NL).

PREFACE

Dear customer, Congratulations on choosing a HAMA Duo-Power 2.0. Thanks to this quality machine from HAMA, you can look forward to years of low maintenance plaster application.

Due to its compact but sturdy build, the HAMA Duo-Power 2.0 is ideally suited to work in construction. The HAMA Duo-Power 2.0 is suitable for spraying plaster and, after conversion, for skim coating as well. Because there are many different nozzles available, it is possible to make use of different spraying patterns. The simple control enables you to work safely and efficiently.

For your safety it is important that the machine is operated maintained correctly. Read this manual before using the machine. Follow the instructions to avoid injury and property damage. Do not hesitate to contact HAMA if you have questions.

TABLE OF CONTENTS

1	INTRODUCTION	5
2	SAFETY	9
3	GENERAL DESCRIPTION	10
4	COMMISSIONING.....	11
5	OPERATION	12
	5.1 Operation of plaster sprayers.....	14
	5.2 Conversion from plaster application to airless spraying.....	16
	5.3 Operating airless spraying	18
	5.4 Conversion from airless spraying to plaster application.....	20
	5.5 Cleaning	22
6	MAINTENANCE.....	24
7	TROUBLESHOOTING	27
8	ENVIRONMENT.....	29
9	DISPOSAL.....	30
10	TECHNICAL SPECIFICATIONS.....	31
11	OPTIONS.....	32
12	SPARE PARTS.....	33

1 INTRODUCTION

Intended use

The HAMA Duo-Power 2.0 is only meant for spraying plaster and skim coating. This can be done in combination with the HAMA H455 compressor.

Intended audience

Only appropriately trained people who have read and understood this manual may use and maintain the HAMA Duo-Power 2.0.

About this manual

This manual describes the operation and maintenance of the HAMA Duo-Power 2.0.

Supplied documentation

The HAMA Duo-Power 2.0 is supplied with the following documentation:
User manual (including spare parts lists)

Availability

The user manual must always be near the HAMA Duo-Power 2.0. If the manual is lost, you can request a new copy from HAMA or download it from www.hama-equipment.com.

Conventions used in this document

- This symbol indicates a summary of information.
- 1. Preceding numbers indicate the order in which steps must be performed.
- [1] Numbers inside square brackets are references to parts in an illustration.

Left, right, front and rear

The designations “left”, “right”, “front” and “rear” are to be interpreted from the forward driving direction, with the side of the electric motor being the “front”.

Customer service

If you have questions about the HAMA Duo-Power 2.0 that are not answered in this user manual, please do not hesitate to contact HAMA. For other instructions you can naturally always consult our website www.hama-equipment.com.

Warranty

You are, of course, entitled to warranty coverage if a defect develops despite correct operation and completion of the prescribed maintenance. The warranty does not cover the following:

- Normal wear
- Ignoring the instructions on the HAMA Duo-Power 2.0
- Ignoring the instructions in this manual
- Inadequate maintenance
- The use of non-OEM parts
- Abnormal external influences
- A modification not authorised by HAMA

HAMA honours the warranty conditions laid down in the METAALUNIE terms and conditions. A summary of the HAMA general terms and conditions is available online on our website.

Machine identification

Fill in the identification data for the machine. These data can be found on the type plate. The type plate can be found on the protective cover on the side of the engine. Fill in the delivery date as well.

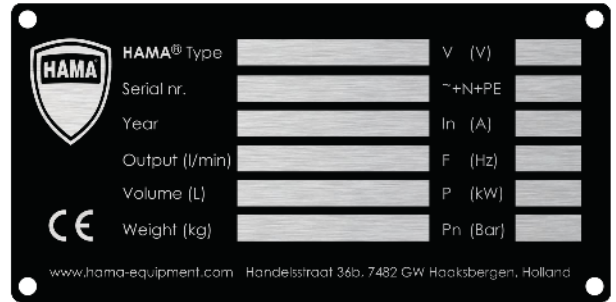

Type	:	<input type="text"/>
Serial number (s/n)	:	<input type="text"/>
Year of manufacture	:	<input type="text"/>
Delivery date	:	<input type="text"/>

You can also register the machine online at www.hama-equipment.com. By registering your product, you make it possible for us to optimize your experience. Registration is beneficial to you in a number of ways, one of which is that we will keep you up to date on the latest developments concerning technical improvements and use of the HAMA Duo-Power 2.0. You will also receive news about the latest developments at HAMA.

EC declaration of conformity (only valid for Europe)

Manufacturer: Modulen & Engineering Menzing B.V.
Address: Handelsstraat 36b
Postal code: 7482 GW

Product identification:

Description of the product: Spack- en dunpleister machine
Type or model: Duo-Power 2.0
Serial number: Pxxxxxx-xxx

Meets the requirements:

EU Guideline: 2006/42/EC relating to machinery
2006/95/EC relating to electrical equipment designed for
use within certain voltage limits
89/336/EEC relating to electromagnetic compatibility

Harmonised standards: EN60204-1 relating to safety of machinery - electrical
equipment for machinery

Haaksbergen, juli 2015



E. Jansen
Director
Modulen & Engineering Menzing B.V.

2 SAFETY

Introduction

Read this manual before using the machine. Follow the instructions to avoid injury and property damage. Do not hesitate to contact HAMA if you have questions.

REMAIN ALERT! YOUR SAFETY AND THE SAFETY OF OTHERS DEPENDS ON IT!

Symbols in this manual

The following symbols are used in this manual:



WARNING

Indicates a risky situation which, if not avoided, may result in severe bodily injury or death.

ATTENTION

Indicates a risky situation which, if not avoided, may result in property damage.



This symbol indicates additional information and tips. This symbol is not used to indicate a risky situation.

It is not permitted to modify the machine without written permission from the manufacturer. Modifications to the machine may cause hazardous situations.

3 GENERAL DESCRIPTION

Introduction

The HAMA Duo-Power 2.0 consists of the following parts:

- Frame with hoppe
- Electric motor
- Transmission
- Control panel
- Pump
 - Plaster pump
 - Skim coat pump

Frame

The frame serves as a base for the HAMA Duo-Power 2.0. A material hopper with a volume of 80 litres is built on to the frame, making it possible to spray plaster without interruption for a longer time.

Electric motor

The Duo-Power 2.0 is powered by a 2.2 kW motor.

Transmission

The transmission ensures that the high rpm of the motor is converted into a lower speed with higher torque so that different materials can be sprayed easily.

Control panel

The control panel contains all the parts that control the HAMA Duo-Power 2.0. One of these parts is a frequency controller that slows the motor and even stops it as soon as you stop spraying.

Pump

The pump ensures that the aggregate to be sprayed from the hopper is pressurised at the required pressure. The HAMA Duo-Power 2.0 is a machine that can be used for two main purposes. The basic machine of the HAMA Duo-Power 2.0 was designed according to the 2-in-1 principle. Two different types of activities, plastering and skim coating, can be done with the same basic machine by simply swapping the pump

- **Plaster pump**

The plaster pump was specially designed for spraying plaster materials. This low pressure pump can generate a pressure of 60 bar with 8 litres per minute

- **Skim coat pump**

The skim coat pump was specially designed for spraying skim coat materials. This high-pressure pump can generate a pressure of 140 bar with 4 to 5 litres per minute.

4 COMMISSIONING

Introduction

Check the HAMA Duo-Power 2.0 for possible transport damage at the time of delivery. Report transport damage to the carrier and your supplier immediately.

Inspection of hopper

Prior to first use, check whether the hopper is completely clean. During transport or storage, items such as wood, coarse gravel, stones or nails could have landed in the machine. These items could cause serious damage to the machine.

Set-up

Make sure that the machine is level prior to use.

Connection to a power supply

The HAMA Duo-Power 2.0 must be connected to a 230 V wall socket with earth connection and must be fused for 16 A.

If no wall socket is available in the immediate area, no more than one fully extended extension reel or extension cord with an earth connection and a minimum core thickness of 2.5 mm² may be used.

ATTENTION

Extension cords that are too long and lightweight can cause undervoltage, causing the electric motor to burn out. HAMA advises using extension cords with a minimum core thickness of 2.5 mm².

ATTENTION

Never connect the HAMA Duo-Power 2.0 in combination with the HAMA H455 compressor to the same fuse group. Both machines on the same fuse group will cause an overload!



The HAMA Duo-Power 2.0 can generate an operating pressure of 140 bar. Leaks due to damage to hoses and couplings can lead to physical injury.



Extension reels must be fully extended in order to prevent fire.



If the HAMA Duo-Power 2.0 is used in combination with the HAMA H455 compressor or another equivalent compressor, each machine must be connected to a separate fuse group of 16 A.

5 OPERATION

Introduction

This chapter provides information about operating the HAMA Duo-Power 2.0 in the plaster application version as well as the skim coat version.



Safety

- All safety markings and hazard designations on the machine must be clearly visible throughout the service life of the machine.
- Only people who have been trained specifically for this are permitted to operate the machine.
- Because compressed air and aggregate hoses could get bent over sharp edges, serious damage could occur that can result in physical injury. Hoses with kinks in them must be replaced immediately.
- Air hoses and aggregate hoses that are to be opened or uncoupled must be depressurised first.
- Persons rectifying blockages in an aggregate hose and spraying tools (spray gun) must make sure that they and bystanders are not sprayed with outgoing aggregates.
- Wear ear protectors. Working with the repair gun or being present in the immediate vicinity of repair work may lead to hearing damage.
- Wear eye protection (safety goggles). The air pressure may cause small hard or liquid particles to deflect off the wall causing damage to eyes.
- Wear a gas mask. Most plaster products contain solvents. This could cause dizziness or even unconsciousness.
- The HAMA Duo-Power 2.0 must be connected to a 230 V wall socket with earth connection and must be fused for 16 A. If no wall socket is available in the immediate area of the workplace, no more than one fully extended extension reel or extension cord with an earth connection and a minimum core thickness of 2.5 mm² may be used.



Safety devices both on the outside of the machine and in the hopper must be present and intact at all times as they were during commissioning. In the event of damaged or lost safety devices, the machine must not be used until it has been restored to its original state.



The HAMA Duo-Power 2.0 may only be used in combination with a compressor that generates a maximum operating pressure van 8 bar such as the HAMA H455 compressor. Higher pressure can lead to serious physical injury.



It is prohibited to stir in the hopper when the machine is operating. Stirring tools may reach through the protective grid to moving parts and cause damage or injury.



It is prohibited to aim the sprayer at parts of your own body or that of others. Contact of the spray material with eyes can cause serious irritation. Rinse eyes immediately by a health & safety officer or a doctor if they are accidently sprayed.

5.1 Operation of plaster sprayers



If the HAMA Duo-Power 2.0 is used in combination with the HAMA H455 compressor or another equivalent compressor, each machine must be connected to a separate fuse group of 16 A.

1. Remove the lid from the hopper and fill the hopper with spray aggregate.
2. If a wringer is used, follow the following steps:

HAMA wringer:

- a. Place the bag on the wringer
- b. Position the handle of the bag between the rollers
- c. Put pressure on the bag
- d. Cut open the bottom with a knife
- e. Turn the handle of the wringer
- f. The aggregate will be deposited in the centre of the hopper
- g. Clean the wringer well after use

Washing machine wringer:

- a. Place the bag between the rollers
- b. Cut open the bottom with a knife
- c. Turn the handle of the wringer
- d. The aggregate will be deposited in the hopper
- e. Clean the wringer well after use

3. Attach the required hose and spray gun without nozzle and connect the air hose.
4. Make sure that the gun is closed..
5. Open the protective cover of the motor and position the V-belt on the smallest pulley of the motor and the largest pulley of the gearbox and close the protective cover again. This step is necessary to allow the rubber in the stator to arrive at the correct operating temperature.
6. The pressure regulation button is on the left side of the machine. This must be set to zero. The button for the rotation direction is on the same side. The legend under this button may differ per machine::

Older machines	-1	0	1
Current machines	Return	Off	On

The rotation direction must be set to “0” or “OFF”.

7. Switch on the main voltage switch on the right side of the machine and press the green "Reset" button.
8. Set the rotation direction switch to "1" or "ON".
9. Keep the gun aimed in the hopper and open the gun. Turn the pressure regulation button to position 4 and wait until the aggregate comes out of the gun. Allow the machine to warm up until the pump is at the required temperature and set the rotation direction button to "0" or "OFF".
10. Turn the pressure regulation button to the 0 position and open the gun until the pressure gauge indicates 0 bar.
11. Now attach the required nozzle.
12. Open the protective cover of the motor and position the V-belt on the centre pulley and close the protective cover again.
13. Push the "RESET" button and set the rotation direction switch to "1" or "ON".
14. Aim the gun into the hopper again and turn the pressure regulation button to a higher position until the required spray distribution or aggregate flow is achieved.



If the pressure regulation button is turned open further but the motor does not run faster, the maximum rpm has been reached. The pressure regulation button may not be turned open even more because, when the gun is closed, a very high pressure could arise, resulting in damage to the hoses and possible injury to the operator or bystanders.

5.2 Conversion from plaster application to airless spraying

The HAMA Duo-Power 2.0 is a multi-purpose machine that can spray plaster as well as airless. Depending on the version of the Duo-Power 2.0 ordered, the machine can easily be converted by replacing the pump with another version. If you purchased the HAMA Duo-Power 2.0 as a plaster application machine and you want to spray skim coat as well, you can convert it into an airless or skim coat machine very easily by replacing the pump with a high-pressure pump.

All conversion steps necessary are described below so that you can be operational again within 20 minutes.

5.2.1 Dismantling process for conversion from plaster to airless

1. Remove all plaster from the hopper.
2. Spray with the aggregate hose until it is completely empty.
3. Rinse the hopper clean with a few litres of water and spray out the dirty water. Repeat this once again and add a small amount of washing-up liquid to prevent corrosion of the pump. If necessary, clean the hopper with water and a paper cleaning cloth. The hose can be cleaned easily with a sponge ball.
4. Depressurise the machine completely and decouple the aggregate hose from the machine.
5. Press the emergency stop and remove the connection cable from the machine.
6. Loosen the three nuts on the nosepiece and remove the nosepiece and the sensor housing. Clean them both with water..
7. Next, the stator together with the rotor can be removed by turning the entire unit back and forth while at the same time pulling on the stator. The bayonet connection on the rotor will now come off easily.

ATTENTION

After removing the pump, we recommend that the rotor of the stator be turned and both parts be cleaned and maintained well. If this is not done, both parts could get stuck because of plaster residue and become unusable!

5.2.2 Assembly process for conversion from plaster to airless

1. Check that there is still no pressure or power on the machine and that the emergency stop is still pressed in as described in the dismantling steps.
2. Remove the safety grill from the interior of the hopper.
3. Install the three thread rod extensions with the nut.
4. Position the bottom and top pump bracket by fastening the seven locking bolts. Only the three bolts on the shores can now be tightened. The other four bolts should not be tightened until the stator is in the correct position.
5. Remove the short shaft in the hopper, clean it with water and put it back in the machine.
6. Place the skim coat stator together with the rotor that has been inserted in the machine and the adaptor ring.
7. NOTE: the bayonet connection of the rotor must be on the same side as the yellow arrow on the stator.
8. Insert your hand into the hopper and support the short shaft until the bayonet connection of the shaft is connected to the rotor.
9. Now reinstall the safety grill in the hopper.
10. Slide the sensor housing over the thread rods on the right side and the protruding catch on the hose side.
11. Place the O-ring in the sensor housing and slide the skim coat nosepiece over the thread rods. Tighten the entire unit with the washers and nuts with a torque of 30 Nm.
12. Now tighten the last four bolts of the pump brackets and mount the aggregate hose on the machine.

ATTENTION

After removing the pump, we recommend that the rotor of the stator be turned and both parts be cleaned and maintained well. If this is not done, both parts could get stuck because of plaster residue and become unusable!

5.3 Operating airless spraying



If the HAMA Duo-Power 2.0 is used in combination with the HAMA H455 compressor or another equivalent compressor, each machine must be connected to a separate fuse group of 16 A.

1. Remove the lid from the hopper and fill the hopper with spray aggregate.
2. If a wringer is used, follow the following steps:

HAMA wringer:

- a. Place the bag on the wringer
- b. Position the handle of the bag between the rollers
- c. Put pressure on the bag
- d. Cut open the bottom with a knife
- e. Turn the handle of the wringer
- f. The aggregate will be deposited in the centre of the hopper
- g. Clean the wringer well after use

Washing machine wringer:

- a. Place the bag between the rollers
- b. Cut open the bottom with a knife
- c. Turn the handle of the wringer
- d. The aggregate will be deposited in the hopper
- e. Clean the wringer well after use

3. Attach the required hose and spray gun without the tip and connect the air hose.
4. Make sure that the gun is closed.
5. Open the protective cover of the motor and position the V-belt on the smallest pulley of the motor and the largest pulley of the gearbox and close the protective cover again. This step is necessary to allow the rubber in the stator to arrive at the correct operating temperature
6. The pressure regulation button is on the left side of the machine. This must be set to zero. The button for the rotation direction is on the same side. The legend under this button may differ per machine:

Older machines	-1	0	1
Current machines	Return	Off	On

The rotation direction must be set to “0” or “OFF”.

7. Switch on the main voltage switch on the right side of the machine and press the green “Reset” button.
8. Set the rotation direction switch to “1” or “ON”.

9. Keep the gun aimed in the hopper and open the gun. Turn the pressure regulation button to position 4 and wait until the aggregate comes out of the gun. Allow the machine to warm up until the pump is at the required temperature and set the rotation direction button to “Zero” or “OFF”.
10. Turn the pressure regulation button to the 0 position and open the gun until the pressure gauge indicates 0 bar.
11. Now attach the required tip.
12. Open the protective cover of the motor and position the V-belt on the centre pulley and close the protective cover again.
13. Push the “RESET” button and set the rotation direction switch to “1” or “ON”.
14. Aim the gun into the hopper again and turn the pressure regulation button to a higher position until the required spray distribution or aggregate flow is achieved.



If the pressure regulation button is turned open further but the motor does not run faster, the maximum rpm has been reached. The pressure regulation button may not be turned open even more because, when the gun is closed, a very high pressure could arise, resulting in damage to the hoses and possible injury to the operator or bystanders.

5.4 Conversion from airless spraying to plaster application

The HAMA Duo-Power 2.0 is a multi-purpose basic machine that can spray plaster as well as airless. Depending on the version of the Duo-Power 2.0 ordered, the machine can easily be converted by replacing the pump with another version. If you purchased the HAMA Duo-Power 2.0 as a skim coat spraying machine and you want to spray plaster as well, you can convert it into a plastering machine very easily by replacing the high-pressure pump with a low-pressure pump.

All conversion steps necessary are described below so that you can again be operational within 20 minutes.

5.4.1 Dismantling process for conversion from skim coat to plaster

1. Remove all skim coat from the hopper.
2. Spray with the aggregate hose until it is completely empty.
3. Rinse the hopper clean with a few litres of water and spray out the dirty water. Repeat this once again and add a small amount of washing-up liquid to prevent corrosion of the pump. If necessary, clean the hopper with water and a paper cleaning cloth.
4. Depressurise the machine completely and decouple the aggregate hose from the machine.
5. Press the emergency stop and remove the connection cable from the machine.
6. Loosen the three nuts on the nosepiece and remove the nosepiece and the sensor housing. Clean them both with water.
7. Next, remove the three thread rod extensions with the nuts.
8. Remove the bottom and top pump brackets by removing the seven locking bolts. The shores on the left, right and top must remain on the machine. NOTE: these parts are necessary later to reconvert the machine to airless so keep them together.
9. Next, the stator together with the rotor and adaptor ring can be removed by turning the entire unit back and forth while at the same time pulling on the stator. The bayonet connection on the rotor will now come off easily.

ATTENTION

After removing the pump, we recommend that the rotor of the stator be turned and both parts be cleaned and maintained well. If this is not done, both parts could get stuck because of plaster residue and become unusable!

5.4.1 Assembly process for conversion from skim coat to plaster

1. Check that there is still no pressure or power on the machine and that the emergency stop is still pressed in as described in the dismantling steps.
2. Remove the safety grill from the interior of the hopper.
3. Remove the short shaft in the hopper, clean it with water and put it back in the machine.
4. Next, position the stator together with the rotor that has been inserted in the machine.
5. NOTE: the bayonet connection of the rotor must be on the same side as the yellow arrow and lock bolt on the stator. Additionally, the terminal blocks of the Roza stator must point up so that the prop of the machine falls precisely in between here.
6. Insert your hand into the hopper and support the short shaft until the bayonet connection of the shaft is connected to the rotor.
7. Next, reinstall the safety grill in the hopper.
8. Slide the sensor housing over the thread rods with the sensor cable on the left side and the protruding catch on the machine side.
9. Next, place the hard paper gasket against the sensor housing and slide the plaster nosepiece over the thread rods. Tighten the entire unit with the washers and nuts with a torque of 30 Nm.
10. Next, tighten the clamps of the Roza stator equally until 60 bar is reached. Next, tighten the lock bolt.
11. Next, mount the aggregate hose on the machine

ATTENTION

After removing the pump, we recommend that the rotor of the stator be turned and both parts be cleaned and maintained well. If this is not done, both parts could get stuck because of plaster residue and become unusable!

5.5 Cleaning

5.5.1 Measures to be taken during short stops without complete cleaning

ATTENTION

Keep the machine clean. This not only makes it nicer to work with, but will also show any defects. Moreover, instructions and warnings must be visible on the machine.

1. A short stop means no more than 24 hours.
2. Leave a mix of aggregate and water (50/50) in the machine and hose. Pump this mixture around well so that the entire hose is filled with this mixture.
3. Leave the aggregate hose connected to the machine so that the aggregate does not harden in an airtight space.
4. For the airless, turn the tip in the gun a quarter turn.
5. With plaster, close the red aggregate valve and place the gun in a container with water.

5.5.2 Measures to be taken during prolonged stops

ATTENTION

Never allow the machine to run dry. This will lead to serious wear to the rotor and stator.

5.5.2.1 Cleaning of the machine and hoses

1. A long stops means more than 24 hours.
2. Run the machine until almost empty and scrape the hopper clean or use Scotch Brite on it. Stop the machine as soon as the pump no longer pumps any aggregate.
3. Stop the machine and remove the connection cable. Remove the grid from the hopper and remove the remaining aggregate.
4. Remove the stator and rotor from the machine and twist them apart. Clean both parts thoroughly and spray them with silicone spray.
5. Remove the short shaft from the hopper and clean it as well.
6. Reinstall all parts and fill the hopper with water.

7. Unscrew the screw cover and remove the tip or nozzle.
8. Depressurize the hose by turning the rotation direction button to “-1” or “Return” and uncouple the hose from the machine.
9. Put an orange sponge ball in the coupling of the nosepiece. Make sure that you use the correct size.
10. Connect the hose to the machine and turn the pump on at a low speed and pressure until the orange sponge ball appears again at the end of the spraying tool (gun).
11. Repeat this procedure with the orange sponge ball. The hose is now clean.

5.5.2.2 Cleaning the air gun

1. Clean the nozzle, mixing chamber, screw cover and the screw thread of the mixing chamber with a steel brush.
2. Lubricate the screw thread of the mixing chamber.

5.5.2.3 Cleaning the airless gun

1. Take all of the parts apart and rinse them off thoroughly.
2. To prevent corrosion, all parts can be blown dry with compressed air.

5.5.2.4 Cleaning the couplings

Couplings must be cleaned with water. The fixed parts have rubber sealing rings. These must be removed and rinsed clean with water. Then they can be replaced in the couplings

ATTENTION

There must always be sealing rings in the couplings to prevent leaks.

6 MAINTENANCE

Introduction

The chapter provides information about maintaining the machine.



Safe maintenance

- When performing maintenance and repairs to the HAMA Duo-Power 2.0, the machine must be depressurised.
- When performing maintenance and repairs, always remove the connecting cable to avoid accidental switching on!
- Do not use the HAMA Duo-Power 2.0 if any part is worn or damaged. Only replace parts with genuine HAMA parts.
- Wear close-fitting overalls, safety goggles and safety shoes.
- Use appropriate tools of the correct size.
- Tighten bolts and nuts with the correct torque (see the “Tightening torques” chapter).
- Always have electric faults and failures resolved by a certified electrician. Failure to do so may lead to highly dangerous situations.
- Disconnect the connecting cable from the wall socket immediately when a fault or failure occurs or when electrical parts are damaged.

6.1 Daily maintenance

- Check the cables and hoses for damage.
- Check the safety markings and hazard designations.
- Check whether all safety devices are still intact and present as they were during commissioning.



NEVER use your fingers to try to locate a leak. Use a piece of cardboard.

6.2 Tightening torques



Incorrectly tightened bolts and nuts can cause accidents. Tighten bolts and nuts in accordance with the table below (unless otherwise indicated in this manual).



Original bolts may only be replaced with bolts having the same dimensions and bolt class. Bolts that do not match the original ones can cause accidents.

Dimension	Tightening torques		
	Class 8.8	Class 10.9	Class 12.9
	Nm	Nm	Nm
M6	10	15	18
M8	25	37	43
M10	51	75	87
M12	87	130	150
M12 x 1.5	92	135	155
M14	140	205	240
M14 x 1.5	150	220	260
M16	215	310	370
M16 x 1.5	230	340	390
M18	300	430	510
M18 x 1.5	350	490	580
M20	430	620	720
M20 x 1.5	480	690	800
M22	580	830	970
M22 x 1.5	640	920	1070
M24	740	1060	1240
M24 x 2	810	1160	1350
M24 x 1.5	830	1180	1380
M27	1100	1550	1850
M27 x 2	1190	1700	2000
M30	1500	2100	2500
M 30 x 2	1610	2300	2690
M33	2000	2800	3400
M36	2600	3700	4300



The bolt class is indicated on the bolt head. The tightening torques apply for dry bolts.

6.3 Maintenance schedule

Routine maintenance

Part	Inspect/clean	Daily	Monthly
General	Inspection for leaks and vibration	✓	
General	Inspect belt tension		✓

7 TROUBLESHOOTING

Introduction

Consult the table to resolve problems. Contact your technical department or HAMA if you cannot resolve the problem.

Problem	Possible cause	Solution
Motor will not run	The connecting cable has not been connected.	Insert the plug in the wall socket.
	Wall socket has no power.	Wall socket is faulty or fuse is faulty.
	The connecting cable is faulty.	Replace the connecting cable.
	Cables / wires are damaged or loose.	Replace or fasten cables / wires.
	The extension cord used is too long or too thin.	Replace the extension cord and press the RESET button at the back of the electric motor.
	Rotor is stuck in the stator.	Dismantle and remove the stator and rotor or replace both with a new set.
Motor does turn but there is no or little aggregate.	An external leak has occurred.	Find the external leak and fix it.
	The stator is worn.	Replace the stator.
	The rotor is worn.	Replace the rotor.
	The pump is obstructed.	Dismantle and remove the stator and rotor or replace both with a new set.
	The aggregate hose is obstructed.	Depressurise the aggregate hose and try to unblock it and rinse it out or replace the aggregate hose.
	Spray gun is obstructed.	Rinse the spray gun thoroughly.
	Plaster gun nozzle is obstructed.	Use a thin drill bit to clean out the nozzle.
	Tip of the airless gun is obstructed.	Turn the nozzle of the tip 180° with a key so that the tip is inside out. If this does not help, replace the tip.
	The V-belt tension is too low.	Tighten the V-belt by pulling the slide of the electric motor down using the adjusting bolt. If the adjustment is insufficient, the V-belt must be replaced.
	The V-belt is worn.	Replace the V-belt.
Plaster does come out, but the spray distribution is not right.	The pressure regulation button is not set right.	Reset the pressure regulation button according to the description in the chapter on operation.
	The compressor does not generate any or generates too little air.	Check whether the compressor is on. Check the pressure of the compressor. Connect a compressor that can produce 8 bar with 450 litres per minute such as the HAMA H455 compressor.
	The air hose has a kink in it.	Remove the kink and make sure that the air hose cannot become trapped.
	The air hose leaks.	Replace the air hose.
	The air channels in the nozzle are obstructed.	Remove the nozzle from the spray gun and poke the air channels open with a small drill bit. If this does not help, install a new nozzle.

Problem	Possible cause	Solution
Skim coat does not come out of the tip, but the spray distribution is not right.	The pressure regulation button is not set right.	Reset the pressure regulation button according to the description in the chapter on operation.
	An external leak has occurred.	Find the external leak and fix it.
	The stator is worn.	Replace the stator.
	The rotor is worn.	Replace the rotor.
	The pump is obstructed.	Dismantle and remove the stator and rotor or replace both with a new set.
	The aggregate hose is obstructed.	Depressurise the aggregate hose and try to unblock it and rinse it out or replace the aggregate hose.
	Spray gun is obstructed.	Rinse the spray gun thoroughly.
	Tip of the airless gun is obstructed.	Turn the nozzle of the tip 180° with a key so that the tip is inside out. If this does not help, replace the tip.
	The V-belt tension is too low.	Tighten the V-belt by pulling the slide of the electric motor down using the adjusting bolt. If the adjustment is insufficient, the V-belt must be replaced.
The machine makes a whining noise.	The V-belt tension is too low.	Tighten the V-belt by pulling the motor slide back using the adjusting bolt. If the adjustment is insufficient, the V-belt must be replaced.
	The V-belt is worn.	Replace the V-belt.
	The stator and rotor run dry or are seizing up.	Put aggregate in the hopper. When cleaning, add washing-up liquid to the water.

8 ENVIRONMENT

Introduction

Environmental impact must be prevented as much as possible during use and maintenance of the HAMA Duo-Power 2.0.

Measures to protect the environment

- Operate and maintain your HAMA Duo-Power 2.0 in accordance with the instructions in this manual.
- Dispose of oil filters, spent oil and condensation in accordance with national regulations.
- Dispose of the defective parts in accordance with national regulations.

9 DISPOSAL

Introduction

With normal use and proper maintenance, the HAMA Duo-Power 2.0 will have a very long service life. When the machine is disposed of after many years, this must be done in a safe and environmentally responsible manner. Many of the materials used can be recycled.



Disposal procedure

Follow this procedure:

1. Wear close-fitting overalls, safety shoes and safety glasses.
2. Use appropriate tools of the correct size.
3. Use suitable, safety-tested lifting equipment.
4. Dispose of all oil in accordance with national regulations.
5. Remove all rubber and plastic parts.
6. Remove all electronic parts.
7. Dispose of all parts in accordance with national regulations.

10 TECHNICAL SPECIFICATIONS

Dimensions and weights

Length	mm	1100
Width	mm	550
Height	mm	900
Weight	kg	75

Machine in general

Max. operating pressure air	bar	8
Max. operating pressure plaster	bar	30-40
Max. airless operating pressure	bar	140
Tank volume	L	80
Min. operating temperature	°C	-20
Max. operating temperature	°C	50
Mains power	V	230 / 50 Hz
Max. mains current	A	16
Max. sound level of the machine	dB(A)	70
Max. sound level when spraying	dB(A)	90

Measurements of cables and hose

Length of the connecting cable	m	20-25
Length of the aggregate hose	m	12-25
Drain off aggregate hose for plaster	mm	ø 19-25
Drain off aggregate hose for airless	mm	ø 10-13



The noise level shown above is measured at a distance of 1 metre from the compressor.

11 OPTIONS

There is a conversion package for the HAMA Duo-Power 2.0 available so that, in addition to skim coat or airless, plaster can be sprayed.

Plaster conversion set

Item number: 108414AS701

There is a conversion package for the HAMA Duo-Power 2.0 available so that, in addition to plaster or airless, skim coat can be sprayed.

Airless conversion set

Item number: 108414AS601

Various optional nozzles are available for a variety of plaster aggregates and a range of spray distributions.

Nozzles for plaster application

See the chapter on “spare parts”

Various optional nozzles are available for a variety of skim coat aggregates and a range of spray distributions.

Tips for spraying airless skim coat

See the chapter on “spare parts”

A roller wringer for the HAMA Duo-Power 2.0 is available so that bags of plaster and skim coat can be positioned and squeezed empty easily.

HAMA roller wringer

Item number: 108409AS100



A washing machine wringer for the HAMA Duo-Power 2.0 is available so that bags of plaster and skim coat can be squeezed empty easily.

Washing machine wringer

Item number: 108409BP000

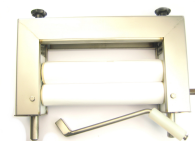

12 SPARE PARTS

Spare parts

Use genuine HAMA parts. You can order these machine-specific parts by visiting www.hama-equipment.com. Genuine HAMA parts are specifically designed for this machine. The use of non-OEM parts can have a negative impact on the operation of the HAMA Duo-Power 2.0 and can make the machine unsafe. HAMA accepts no liability for damage or injury resulting from the use of non-OEM parts.



Parts without a part number are not sold by HAMA as spare parts. However, these are not machine-specific and are available from general suppliers of technical parts.

Basic machine	34
Conversion kit airless pump	36
Conversion kit plaster pump	38
Material hose plaster complete	40
Airless hose kit complete	42
HAMA Nozzle STNK	43
HAMA Nozzle SF	43
HAMA Tip	43

Basic machine

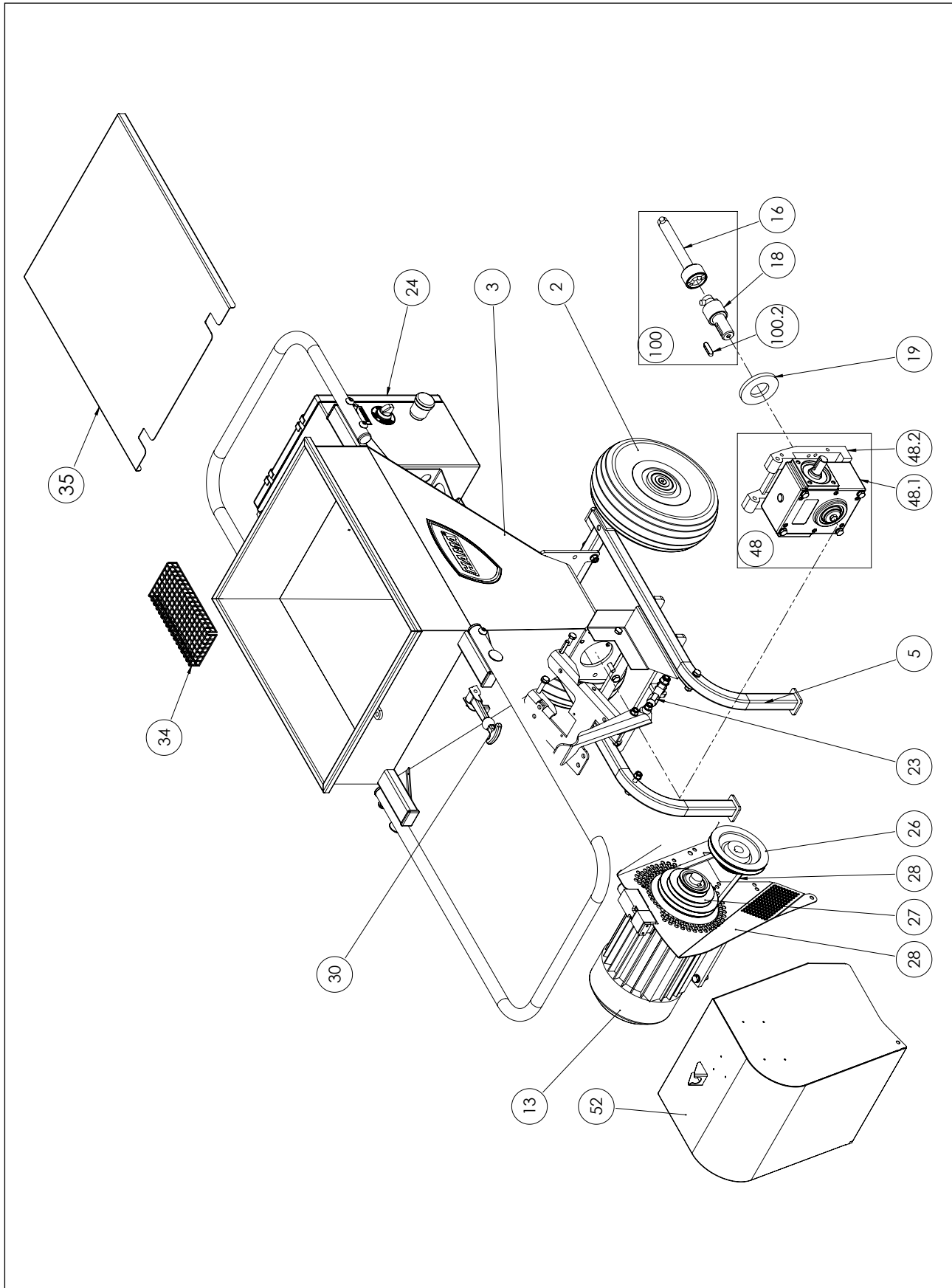

Pos.	HAMA part no.	Description
2	108403BP010	Pneumatic tyre 300x4 with steel rim
3	108411AS022	Stainless steel hopper 80L
5	108411AS021	Frame HAMA duo power
13	108411BP000	Motor
16	108402AS008	Worm shaft
18	108402AS007	Insertion axis
19	108414PA002	Sealing 80X39X8
23	108414AS001	Tensioner
24	On request	Switch Box Airless
26	108414PA005	Pulley 3 stages, gearbox side
27	108414PA006	Pulley 3 stages, motor side
28	108414BP002	V-belt
30	108414BP001	Bonnet rubber
32	On request	Upper side V-belt protection
34	108414PA010	Grid
35	On request	Lid 80L
48	108402AS003	Gear to intermediate flange
48.1	108412BP014	Benzler reductor 14:1
48.2	108414PA014	Flange
48.3	-	Oil-retaining ring 40x56x8
48.4	-	Grease nipple
48.5	-	Bolt M8x40 ELVZ DIN 931
48.6	-	Washer M8 DIN125-1A ST ZPL
48.7	-	Fan
52	On request	Protective cover
100	108411AS026	Shaft set Duo Power
100.1	108402AS007	Insertion axis
100.2	-	Parallel key DIN 6885A
100.3	108402AS008	Worm shaft

Conversion kit airless pump

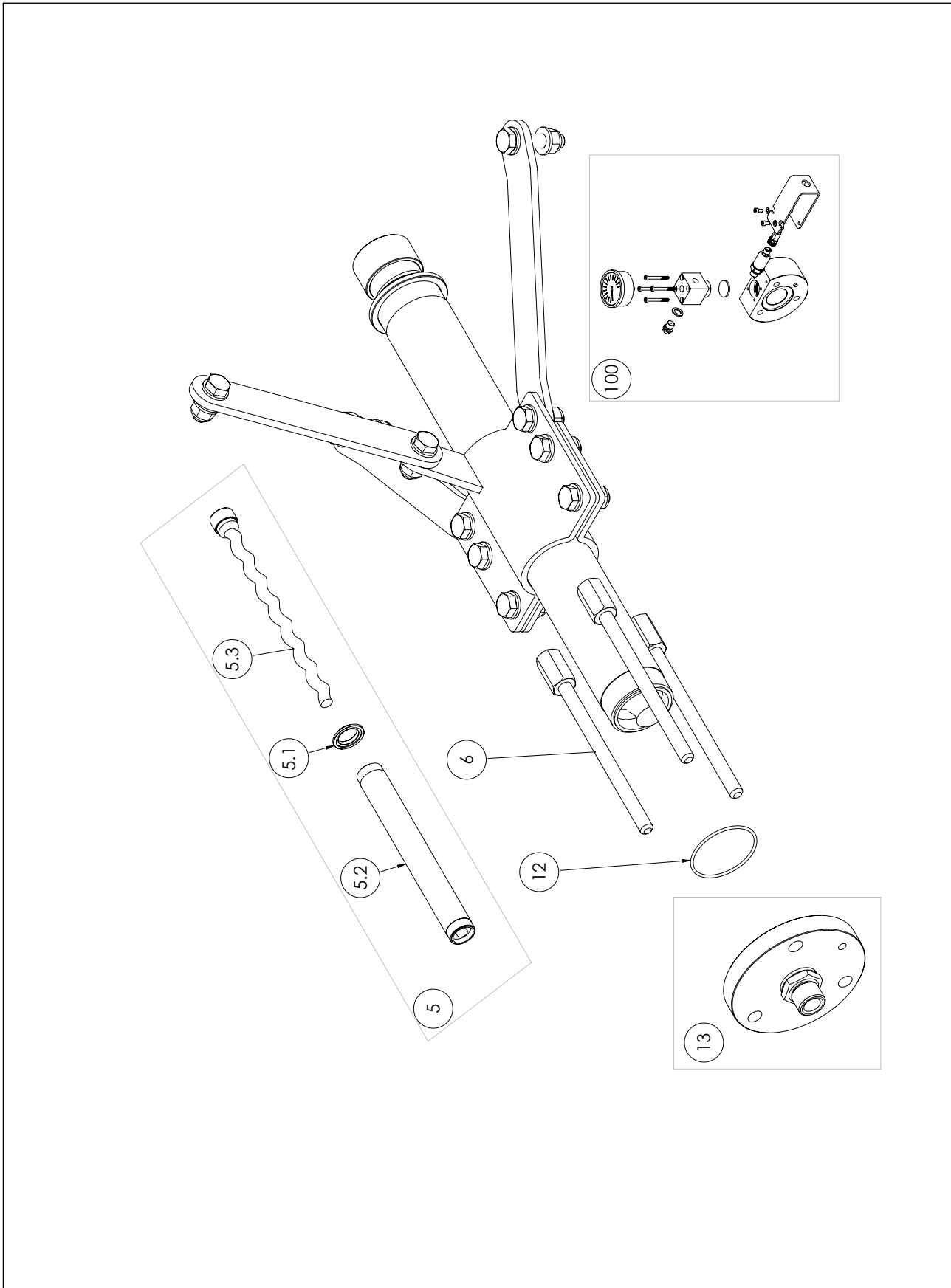

Pos.	HAMA part no.	Description	Qty
0	108414AS601	Conversion kit airless pump (pos 1-13)	
1	-	Bolt 8.8 M10X30	8
2	-	Mounting support	2
3	-	Mounting strip	1
4	-	Bracket	1
5	108411AS060	Airless pump assy	1
5.1	108411PA010	Pump adapter (ø60mm - ø50mm)	1
5.2	108411AS015	Stator	1
5.3	108411AS061	Rotor airless subassy	1
6	108411PA002	Rod M10x160	3
7	-	Washer M10 DIN125-1A ST ZPL	20
8	-	Locking nut DIN985 ZPL M10	10
9	-	Bolt M10x45 DIN 931 8.8 ZPL HX BLT	2
10	-	3D nut M10	3
11	-	Bracket	1
12	OR482	O-RING NBR 48X2	1
13	108414AS603	Nose flange airless subassy	1
13.1	-	Double nipple BSP 1/2" - 1/2"	1
13.2	-	Ring 1/2"	1
13.3	-	Nose flange airless	1
100	108411AS024	Sensor unit assembly	
100.1	-	Manometer	1
100.2	-	Dowel pin	1
100.3	-	Connection block	1
100.4	-	Sensor house	1
100.5	-	Bolt DIN912 10.9 M5X45	4
100.6	-	Sensor protection cap	1
100.7	-	Bolt DIN912 8.8 M5X10	2
100.8	-	Washer M5 DIN125-1A ST ZPL	2
100.9	-	Membrane	1
100.10	-	Pressure sensor 0-250 bar	1
100.11	-	Stop with vent	1
100.12	-	Ring 1/4"	1
100.13	-	Cable	1

Conversion kit plaster pump

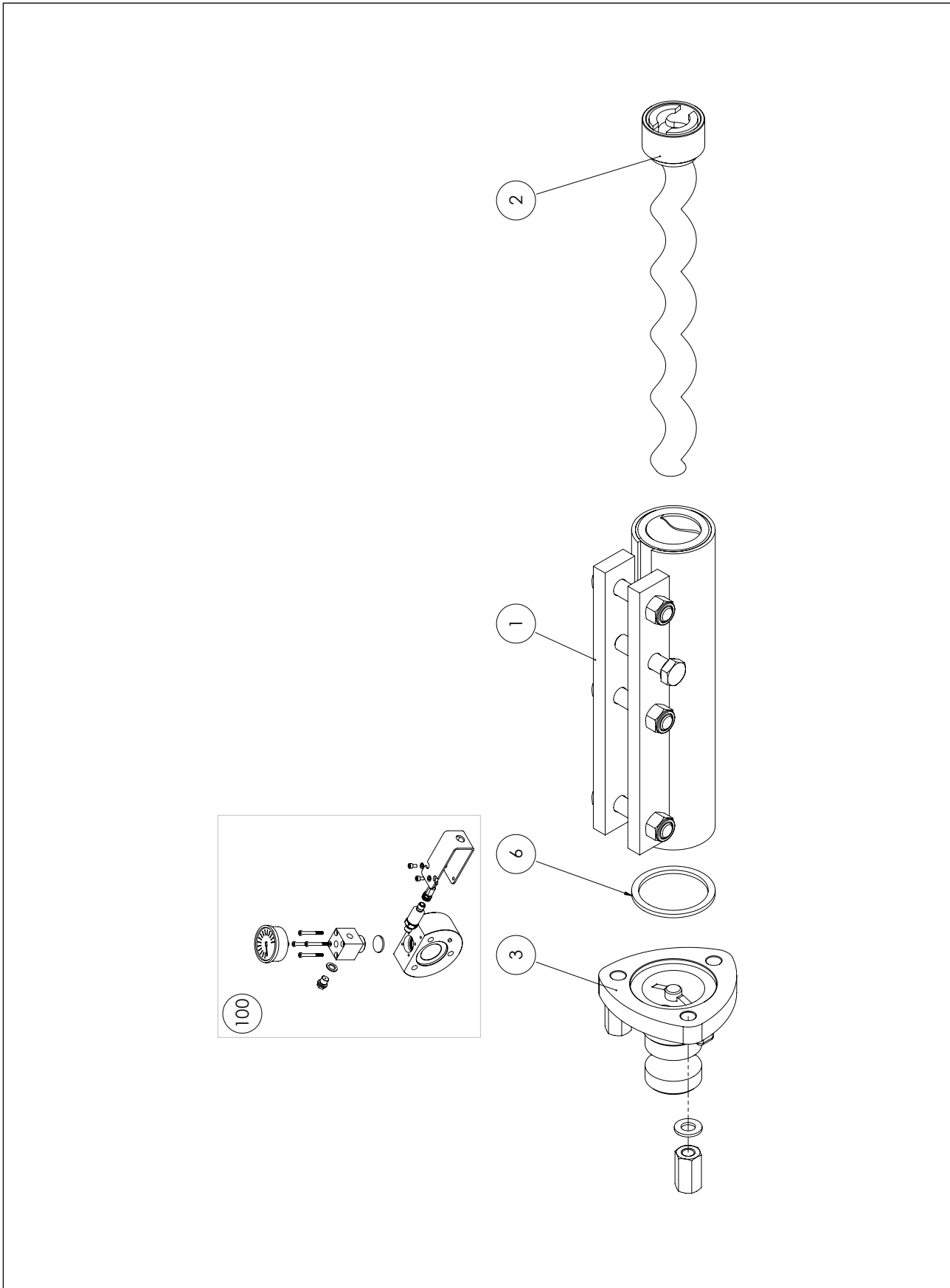

Pos.	HAMA part no.	Description	Qty
0	108414AS601	Conversion kit plaster pump (pos 1-6)	
1	108414PA700	Pump ROZA (Stator)	1
2	108414AS706	Rotor Roza with bush	1
3	108414AS702	Nose part ROZA	1
4	-	Washer M10 DIN125-1A ST ZPL	3
5	-	3D nut M10	3
6	108411PA041	Sealing ring 60x50x3	1
100	108411AS024	Sensor unit assembly	
100.1	-	Manometer	1
100.2	-	Dowel pin	1
100.3	-	Connection block	1
100.4	-	Sensor house	1
100.5	-	Bolt DIN912 10.9 M5X45	4
100.6	-	Sensor protection cap	1
100.7	-	Bolt DIN912 8.8 M5X10	2
100.8	-	Washer M5 DIN125-1A ST ZPL	2
100.9	-	Membrane	1
100.10	-	Pressure sensor 0-250 bar	1
100.11	-	Stop with vent	1
100.12	-	Ring 1/4"	1
100.13	-	Cable	1

Material hose plaster complete

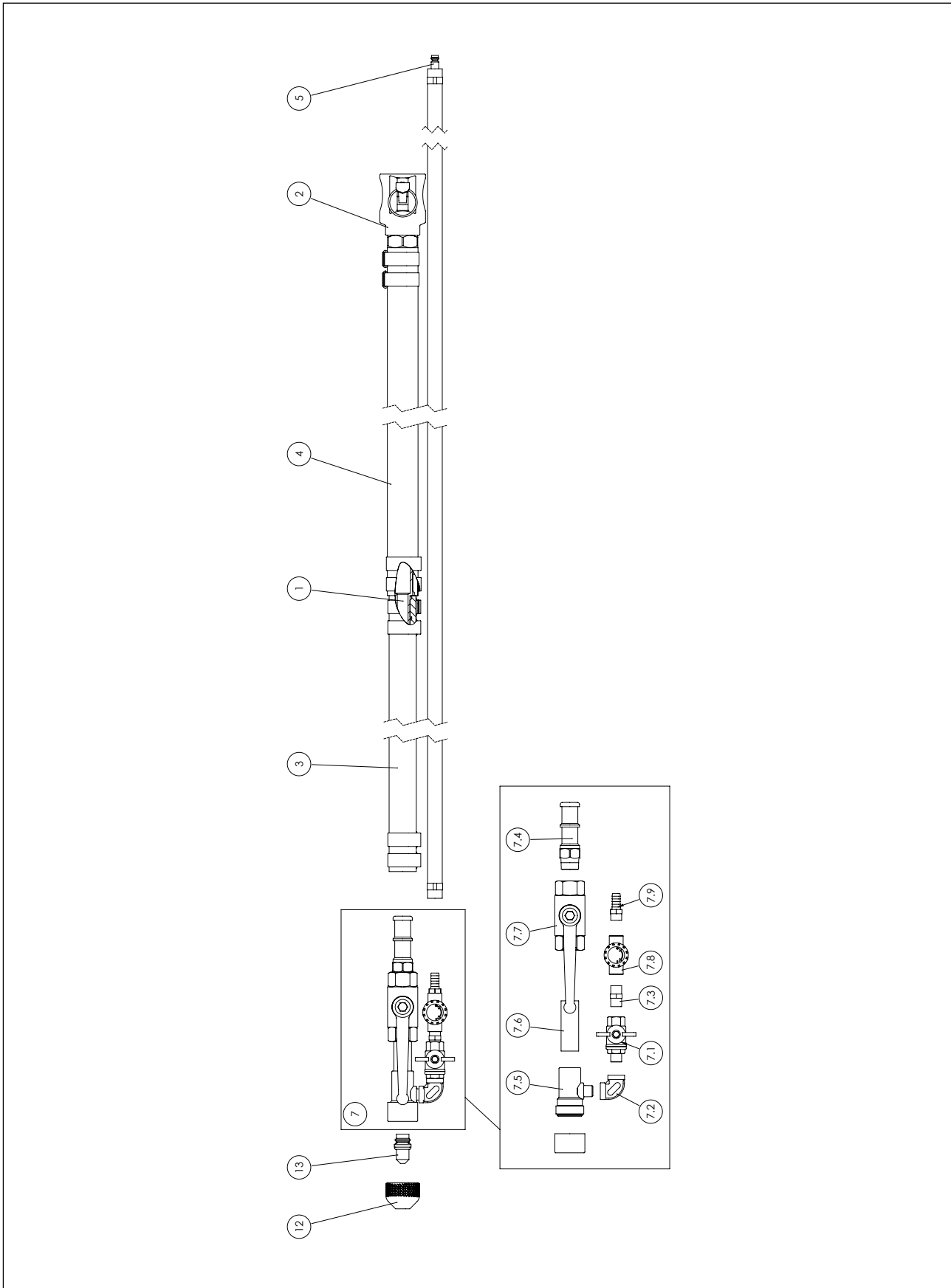

Pos.	HAMA part no.	Description	Qty
0	108414AS703	Material hose plaster complete (Pos. 1-13)	
1	108414PA703	Reducing hose tail 3/4" - 1/2"	1
2	108414AS705	Coupling + 25mm tule	1
3	108414BP701	Hose 6m, 19 mm	1
4	108414BP702	Hose 12m, 25mm	1
5	108414BP704	Plug-in nipple + 10mm tule	1
7	108414AS704	spraying equipment spack assembly	1
7.1	108401BP017	Ball valve 1/4"	1
7.2	108401BP016	Knee 1/4"BI-BI RVS316	1
7.3	108401BP018	Double Nipple 1/4" BU	1
7.4	108414PA702	Tule R1/2" 2x19mm SW24	1
7.5	108401AS104	Mixing chamber MC3V	1
7.6	108401BP014	Pipe nipple 1/2"x60 mm	1
7.7	108414BP706	Carbon steel ball valve - 1/2" G - 500 bar	1
7.8	108401BP019	Needle valve 1/4"	1
7.9	108414BP700	hosetails spi 10 x 1/4"	1
12	108401AS105	Air cap with O-ring	1
13	108400AS204	Nozzle STNK Ø4 mm with O-ring	1

Airless hose kit complete

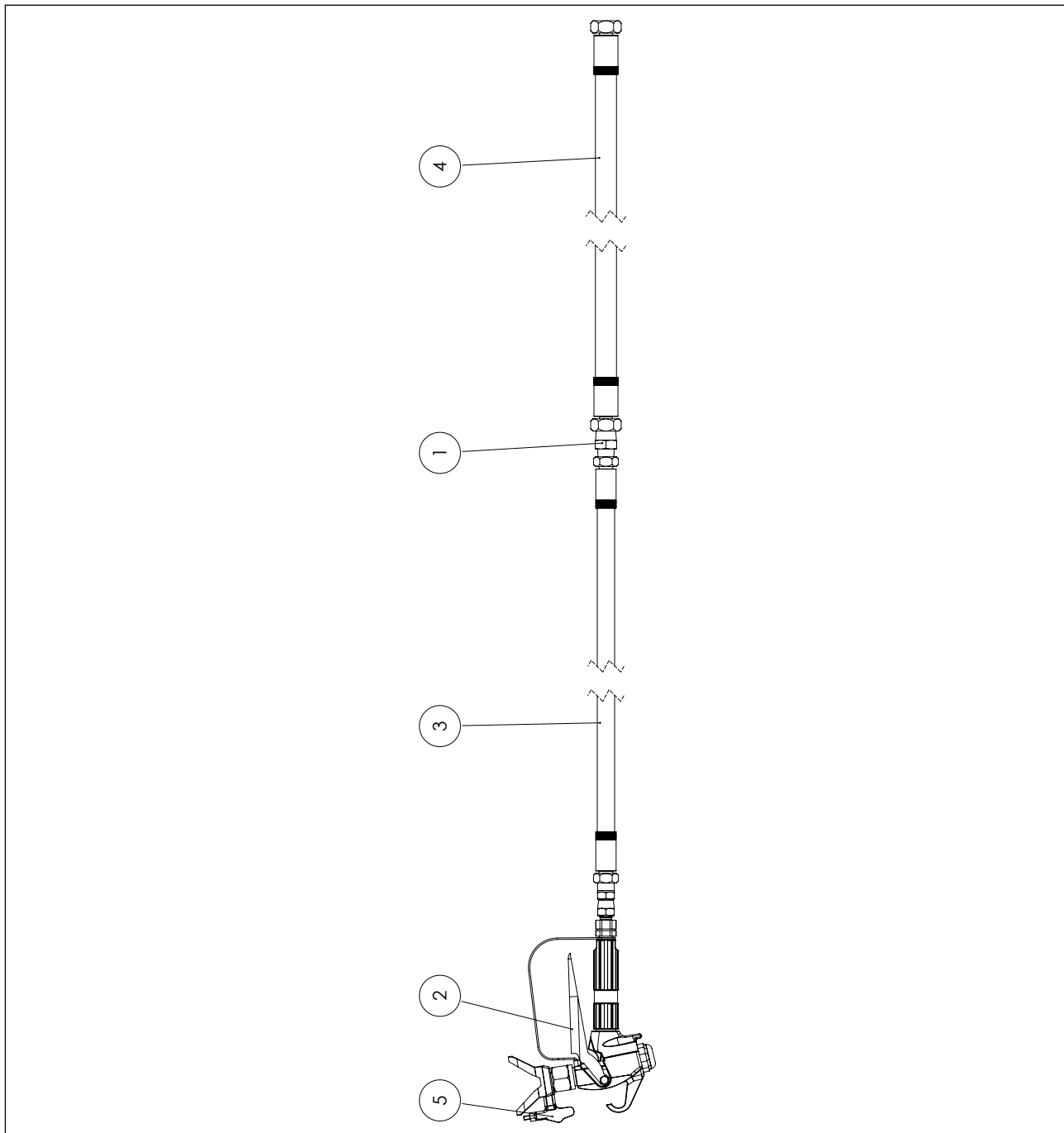

Pos.	HAMA part no.	Description	Qty
1	108414BP600	Adapter 3/8 NPT m x 1/2 NPT m	1
2	108414BP601	HAMA airless spray gun	1
3	108414BP602]High pressure hose DN10 2,5 meter 3/8" NPSM	1
4	108414BP603	Spray hose DN13 15 meter 1/2" NPSM VA- DKR 1/2" 230 (bar)	1
5	108414BP535	HAMA TIP 535	1

HAMA Nozzle STNK

STNK = standard nozzle

HAMA part no.	Description
108400AS202	Nozzle STNK Ø2 mm with O-ring
108400AS203	Nozzle STNK Ø3 mm with O-ring
108400AS204	Nozzle STNK Ø4 mm with O-ring
108400AS235	Nozzle STNK Ø3,5 mm with O-ring
108400AS205	Nozzle STNK Ø5 mm with O-ring
108400AS206	Nozzle STNK Ø6 mm with O-ring
108400AS207	Nozzle STNK Ø7 mm with O-ring
108400AS208	Nozzle STNK Ø8 mm with O-ring
108400AS209	Nozzle STNK Ø9 mm with O-ring
108400AS210	Nozzle STNK Ø10 mm with O-ring



HAMA Nozzle SF

SF = nozzle for delicate particle

HAMA part no.	Description
108400AS253	Nozzle 3 mm SF with O-ring
108400AS254	Nozzle 4 mm SF with O-ring
108400AS255	Nozzle 5 mm SF with O-ring



HAMA Tip

HAMA part no.	Description
108414BP535	HAMA Tip 535
108414BP625	HAMA Tip 625
108414BP635	HAMA Tip 635

