

NetSure™ Rectifier Module

User Manual, UM1R482000E3 (Revision F, July 20, 2015)

Specification Number: 1R482000E3
Model Number: R48-2000e3

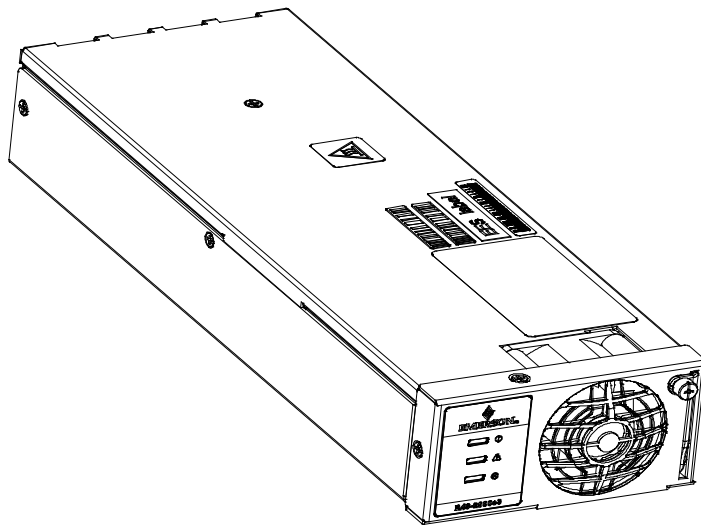

This page is intentionally blank.

Table of Contents

Admonishments Used in this Document	ii
Static Warning	iii
Introduction	1
Overview	1
Specifications	1
Operation	8
AC Input Protection Device Requirements/Recommendations.....	8
Local Indicators.....	8
Rectifier High Voltage Shutdown and Lockout Restart	8
Rectifier Current Limit.....	8
Installing Rectifiers	10
Troubleshooting and Repair	10
Troubleshooting.....	10
Replacement Procedures	12

Admonishments Used in this Document



DANGER! Warns of a hazard the reader **will** be exposed to that will **likely** result in death or serious injury if not avoided. (ANSI, OSHA)



WARNING! Warns of a potential hazard the reader **may** be exposed to that **could** result in death or serious injury if not avoided. This admonition is not used for situations that pose a risk only to equipment, software, data, or service. (ANSI)



CAUTION! Warns of a potential hazard the reader **may** be exposed to that **could** result in minor or moderate injury if not avoided. (ANSI, OSHA) This admonition is not used for situations that pose a risk only to equipment, data, or service, even if such use appears to be permitted in some of the applicable standards. (OSHA)



ALERT! Alerts the reader to an action that **must be avoided** in order to protect equipment, software, data, or service. (ISO)



ALERT! Alerts the reader to an action that **must be performed** in order to prevent equipment damage, software corruption, data loss, or service interruption. (ISO)



FIRE SAFETY! Informs the reader of fire safety information, reminders, precautions, or policies, or of the locations of fire-fighting and fire-safety equipment. (ISO)



SAFETY! Informs the reader of general safety information, reminders, precautions, or policies not related to a particular source of hazard or to fire safety. (ISO, ANSI, OSHA)

Static Warning



This equipment contains static sensitive components. The warnings listed below must be observed to prevent damage to these components. Disregarding any of these warnings may result in personal injury or damage to the equipment.

1. Strictly adhere to the procedures provided in this document.
2. Before touching any equipment containing static sensitive components, discharge all static electricity from yourself by wearing a wrist strap grounded through a one megohm resistor. Some wrist straps, such as Emerson Network Power Part Number 631810600, have a built-in one megohm resistor; no external resistor is necessary. Read and follow wrist strap manufacturer's instructions outlining use of a specific wrist strap.
3. Do not touch traces or components on equipment containing static sensitive components. Handle equipment containing static sensitive components only by the edges that do not have connector pads.
4. After removing equipment containing static sensitive components, place the equipment only on conductive or anti-static material such as conductive foam, conductive plastic, or aluminum foil. Do not use ordinary Styrofoam™ or ordinary plastic.
5. Store and ship equipment containing static sensitive components only in static shielding containers.
6. If necessary to repair equipment containing static sensitive components, wear an appropriately grounded wrist strap, work on a conductive surface, use a grounded soldering iron, and use grounded test equipment.

This page is intentionally blank.

Introduction

Overview

The rectifier provides load power, battery float current, and battery recharge current during normal operating conditions. The rectifier is a constant power design. The rectifier is rated at its maximum output power. This means that, within the normal operating ambient temperature range and input voltage range, the maximum available output power is a constant 2000W. Within these ranges, the rectifier operates in one of three modes, depending upon load demands. Transition between modes is completely automatic. If ambient temperature rises above or input voltage falls below acceptable values, the rectifier continues to operate but at derated output power levels.

- Constant Voltage Mode:** For any initial output voltage setting from 42 to 58 volts, output voltage remains constant regardless of load. This is the normal operating condition, in which loads are being supplied and batteries are float charged. Rectifiers operate in the Constant Voltage Mode unless load increases to the point where the product of load current and output voltage is approximately 2000W.
- Constant Power Mode:** As load increases above approximately 2000W (non-adjustable), output current continues to increase, but output voltage decreases as required to maintain constant output power. Rectifiers operate in the Constant Power Mode unless load continues to increase to the point where the current limit setting is reached.
- Constant Current Mode:** If load increases to the current limit setting, output voltage decreases linearly to maintain output current at the current limit setting.

Specifications

DC Output Ratings

Note: A current limitation can be set by the User and the output voltage level is set through the controller.

- Voltage:** Nominal -48 volts DC, positive ground. Output voltage is adjustable from -42 to -58 volts DC via the associated Controller.
- Output Power and Current:** 2000W (41.7A) @ 120/208/240VAC input and -48VDC output.
- Output Characteristics:** Refer to [Figure 1](#) for a graph of output voltage vs. output current.

Figure 1. Output Voltage vs. Output Current

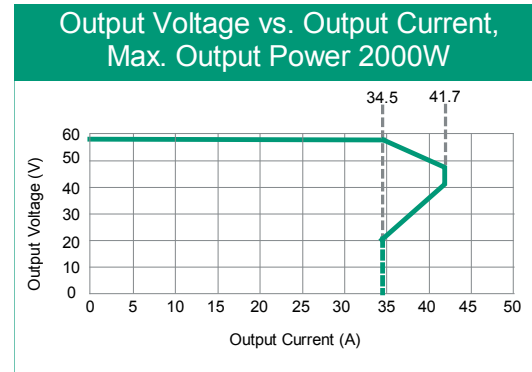

- Power Derating Based on Input Voltage:** The rectifier power varies with changes in input voltage and output voltage. It uses an advanced power limitation method. The lower input threshold is 85 VAC. The rectifier can provide its maximum rated power (2000W) as long as the input voltage is within the range of 176 to 300VAC. Below 176 VAC, and down to 85 VAC, the rectifier will continue to operate normally but will be in a power derating mode. The relationship between the output power and input voltage is illustrated in [Figure 2](#).

Figure 2. Power Derating Based on Input Voltage

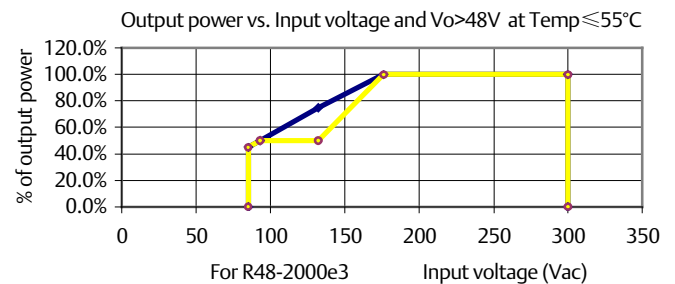

Note: **Blue Line:** Linear derating from 85V AC to 176V AC.
Yellow Line: Linear derating from 2000 watts at 176V AC to 1000 watts at 132V AC. Constant 1000 watts from 132V AC to 93V AC.

- Power Derating Based on Temperature:** The rectifier delivers full power when operating at an ambient temperature of +55°C (+131°F) or below. Each rectifier continuously monitors the ambient temperature surrounding the power conversion circuit. If this temperature for any reason (such as a high ambient temperature) increases above approximately +55°C (+131°F), the rectifier will not shut down. Rather, the rectifier limits its maximum output power to maintain the temperature of the power conversion circuit within design parameters. Operation between +55°C (+131°C) and +80°C (+176°F) will result in output power being decreased. Full power capability is restored when the

temperature decreases to below approximately +55°C (+131°F). Refer to Figure 3 to view the relationship between the output power and the ambient temperature.



WARNING! The module is rated for continuous operation at full output power up to +55°C (+131°F). Operation between +55°C (+131°F) and +80°C (+176°F) will result in output power decrease. Operation above +80°C (+176°F) is considered abnormal and should be used on a temporary¹ basis only.

¹ **Temporary Operation at Abnormal Temperature:** Temporary operation is defined as a period of not more than eight consecutive hours per day, and a total of not more than 15 days in a year. (This refers to a total of 120 hours in any given year, but no more than 15 occurrences in that one-year period.)

Other power rating values are as follows (refer to Figure 3):

- At an ambient temperature of +65°C (+149°F), the power delivered by the rectifier is 1800W.
- At an ambient temperature of +70°C (+158°F), the power delivered by the rectifier is 1500W.

Figure 3. Power Derating Based on Temperature

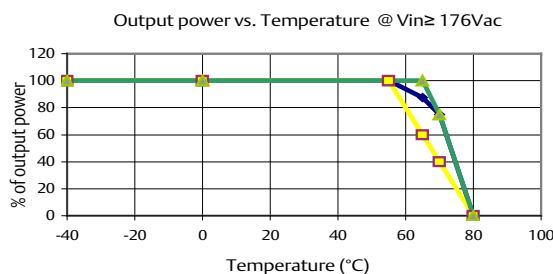

Note: **Green Line:** at 200Vac < Vin < 250Vac and 50Vdc < Vout < 56Vdc.

Blue Line: at 176Vac < Vin < 300Vac and 48Vdc < Vout < 58Vdc, exclude Region 1.

Yellow Line: 264Vac < Vin < 300Vac and Vout < 42Vdc.

Note: 2000W @ +65°C (+149°F) and 200Vac < Vin < 250Vac and 50Vdc < Vout < 56Vdc.

- Regulation:**
 - Static:** Steady state regulation is ±0.6% as controlled within the rectifier for any and all combinations of load from no load to full load, input voltage, and

input frequency at a constant ambient temperature. The associated system Controller may provide increased regulation.

- Dynamic:** For any step load change within the range of 10% to 90% of full load within 50 microseconds, per Telcordia GR-947-CORE, the maximum voltage transient will not exceed 5% of the initial steady state voltage within 50±10 microseconds. Recovery to within 1% of the initial steady state voltage does not exceed 1 milliseconds.

- Filtering:**

- Voice Band Noise:** Complies with Telcordia GR-947-CORE.
 - Output noise according to Telcordia GR-947-CORE is < 38 dBmC typical at normal input and 20% to 70% of rated load for more than one rectifier.
 - Psophometric noise is ≤ 2 mV typical at 20% to 70% of rated load for more than one rectifier.
- Wide Band Noise:** Complies with Telcordia GR-947-CORE.
 - Wideband noise emission is < 250 mV peak to peak between 0 Hz - 100 MHz, and < 50 mV rms in any 3 kHz band 10 KHz - 20 MHz.

AC Input Ratings

- Voltage:** Nominal 120/208/240 volts AC, single phase, 3-wire, 50/60 Hz, with an operating range of 100 to 250 volts. Acceptable input frequency range is 45 to 65 Hz.
- Permitted Variation:** 85 to 300 VAC.
- Harmonic Content (THD):** ≤5% from 50% to 100% of rated load. Meets EN61000-3-2.
- Inrush Current:** Peak does not exceed 1.5 times of the peak value of the maximum steady-state input current at full load, nominal input voltage, and for any duration of AC input interrupts. Under the above conditions, standard AC distribution circuit breakers will not trip.
- Typical Input Data:** 50 Hz input.
 - Refer to Table 1.
 - Maximum Input Current:** Refer to Table 2.

Table 1. Typical Input Data in 50Hz Input

Nominal Input Voltage	Percent of Full Load	Input Current (Amperes)	Input VA	Input Watts	Power Factor %	Efficiency % Heat	Heat Dissipation BTU/Hr
208	0	0.32	70.80	33.20	46.90	--	113.27
	25	2.24	497.20	491.90	98.90	95.38	77.54
	50	4.71	983.00	977.40	99.40	96.01	133.05
	75	7.08	1476.10	1473.00	99.70	95.51	255.65
	100	9.53	1980.00	1984.30	99.80	94.50	372.35
	110	10.30	2144.00	2141.00	99.80	94.27	418.56
	120	10.34	2151.00	2147.00	99.80	93.88	454.89
240	0	0.32	73.50	26.50	36.00	--	90.41
	25	2.08	499.80	490.80	98.00	95.58	74.01
	50	4.09	983.90	974.70	99.00	96.27	124.04
	75	6.13	1472.80	1466.30	99.50	95.94	203.11
	100	8.23	1974.20	1968.90	99.70	95.24	319.75
	110	8.90	2133.00	2129.00	99.70	94.87	372.63
	120	8.93	2142.00	2138.00	99.70	94.38	409.95

Note: System output is initially adjusted to 54.48 volts DC as measured at the system sense point at 50% of full load and nominal input. "Percent of Full Load" refers to percent of 34.5 amperes.

Table 2. Maximum Input Current in 50Hz Input

Nominal Input Voltage	Input Voltage	Input Current (Amperes)
208/240	176	11.73

Note: At 100% of full load with output adjusted to 58 volts DC as measured at the shelf output terminals.

- **Typical Input Data:** 60 Hz input.
 - a. Refer to [Table 3](#).
 - b. **Maximum Input Current:** Refer to [Table 4](#).

Table 3. Typical Input Data in 60Hz Input

Nominal Input Voltage	Percent of Full Load	Input Current (Amperes)	Input VA	Input Watts	Power Factor %	Efficiency % Heat	Heat Dissipation BTU/Hr
208	0	0.34	73.20	29.60	40.43	--	100.99
	25	2.39	499.90	492.40	98.50	95.27	79.46
	50	4.73	985.80	978.10	99.20	95.94	135.49
	75	7.09	1479.60	1474.00	99.60	95.43	229.83
	100	9.54	1985.80	1982.20	99.70	94.59	365.87
	110	10.31	2147.00	2142.00	99.80	94.24	420.95
	120	10.35	2154.00	2149.00	99.80	93.82	452.12
240	0	0.36	105.40	31.80	30.55	--	108.5
	25	2.10	504.70	491.00	97.20	95.59	73.88
	50	4.11	989.30	975.90	98.60	96.18	127.19
	75	6.15	1478.00	1469.60	99.30	95.73	214.10
	100	8.25	1978.70	1972.20	99.60	95.08	331.10
	110	8.92	2140.00	2132.00	99.60	94.78	379.70
	120	8.95	2147.00	2140.00	99.60	94.32	414.71

Note: System output is initially adjusted to 54.48 volts DC as measured at the system sense point at 50% of full load and nominal input. "Percent of Full Load" refers to percent of 34.5 amperes.

Table 4. Maximum Input Current in 60Hz Input

Nominal Input Voltage	Input Voltage	Input Current (Amperes)
208/240	176	11.73

Note: At 100% of full load with output adjusted to 58 volts DC as measured at the shelf output terminals.

- Efficiency Curve (Refer to Figure 4.)

Figure 4. Efficiency Curve

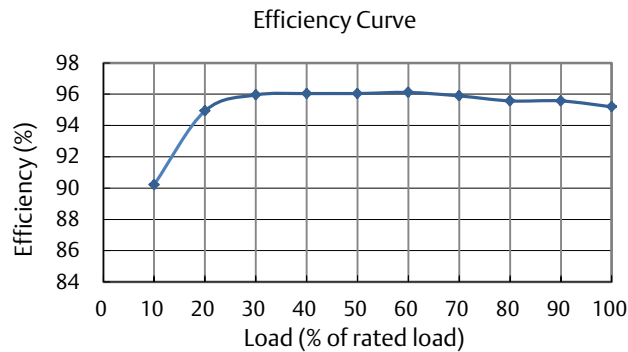

Environmental Ratings:

- **Operating Ambient Temperature Range:**
 - +55°C (+131°F) to +80°C (+176°F) with derating output.
 - 40°C (-40°F) to +55°C (+131°F) with full power performance.
- **Temperature Coefficient:** 0.02% per degrees Celsius.
- **Storage Ambient Temperature Range:** -40°C (-40°F) to +70°C (+158°F).
- **Relative Humidity:** This rectifier is capable of operating in an ambient relative humidity range of 0% to 95%, non-condensing.
- **Altitude:** 2000 m (6560 ft) at full power (power limited for heights above 2000 m).
- **Surge Protection:** Compliance with EN61000-4-5 (4kV Line to Line, 4kV Line to Earth). Capable of withstanding surges per ANSI/IEEE C 62.41 1999 Category B3 across the input terminals.

Note: This level of protection is a widely used standard for telecommunications power equipment. As with all such equipment, it is the end user's responsibility to provide an adequately sized Surge Suppression Device at the commercial power service entrance of the building that reduces all incoming surges to levels below the classes/categories stated for the equipment.
- **Ventilation Requirements:** The rectifiers are fan cooled and utilize front to back forced ventilation. A rectifier must be mounted so ventilating openings are not blocked and temperature of the air entering the rectifier

does not exceed the Operating Ambient Temperature Range stated above.

- **Single Rectifier Audible Noise:** At 25°C ≤50dB(A) with fan in high speed. Measurement made at 0.6m distance in front of rectifier and at same horizontal line of the middle of rectifier.
 - **High Voltage Category:** II
 - **Power Distribution System:** TN/TT/IT
- Note: The rectifier module is recommended to be used in an environment with Pollution of Degree 2 or less. Pollution Degree 2 applies where there is only non-conductive pollution that might temporarily become conductive due to occasional condensation (such as the office environment).*
- **EMI/RFI Suppression:**
 - Rectifiers operating in an approved rectifier mounting shelf conform to the requirements of FCC rules Part 15, Class B for Radiated and Conducted emissions limits.
 - Rectifiers operating in an approved rectifier mounting shelf conform to the requirements of European Norm, EN55022, Class B for Radiated and Conducted emissions limits.

Compliance Information

- **EMC:** ETSI EN 300 386, FCC CFR 47 Part 15 class B, Telcordia GR-1089-CORE.
- **EMI Load Range:** 10-100%.
- **Safety:** IEC 60950, EN 60950, UL 60950.
- **GR-3108 Class 2 Compliant**

Standard Features

- **Type of Power Conversion Circuit:** High frequency.
- **Constant Voltage Mode:** For any initial output voltage setting from 42 to 58 volts, output voltage remains constant regardless of load. This is the normal operating condition, in which loads are being supplied and batteries are float charged. Rectifiers operate in the Constant Voltage Mode unless load increases to the point where the product of load current and output voltage is approximately 2000W.
- **Constant Power Mode:** As load increases above approximately 2000W (non-adjustable), output current continues to increase, but output voltage decreases as required to maintain constant output power. Rectifiers operate in the Constant Power Mode unless load continues to increase to the point where the current limit setting is reached.
- **Constant Current Mode:** If load increases to the current limit setting, output voltage decreases linearly to maintain output current at the current limit setting.
- **Input Protection:**
 - a. **Input Over/Under Voltage Protection:** The rectifier will shut down at low or high voltage input; based on the following voltage levels:
 1. Low Voltage Disable Point: 80V, ± 5 V; hysteresis is 15 VAC for restart.
 2. High Voltage Disable Point: 305V, ± 5 V; hysteresis is 10 VAC for restart.
 - b. Between 85 V and 176 V the output power will be derated linearly based on the input voltage as follows:
 1. At input voltage of 85V with output >48V, max output power is 800W.
 2. At input voltage of 120V with output >48V, max output power is 1364W.
 3. At input voltage of 154V with output >48V, max output power is 1750W.
 4. At input voltage of 176V and output >48V, max output power is 2000W.
- **Output Protection:**
 - a. **Overload / Reverse Current:** The rectifier has a 63A fuse in the negative output DC bus. This fuse is not customer replaceable. The rectifier can be plugged into or pulled out of a shelf while operating, without damage or opening the fuse.
 - b. **Current Limiting:** The rectifier has a current limit function. The current limit point can be set between the range of 4 to 41.7 A, adjustable via the Controller. The current limit accuracy is ± 1.5 A when the output voltage ranges from 42 to 58 V. Below 42 V the current will fold back to a lower value.
 - c. **Advanced Current Limit Function:** The rectifier has an advanced Current Limit Function. When a short circuit occurs at the rectifier output terminals, the rectifier will keep its output current at a value below the maximum current limit set point. This function effectively protects the rectifier and the equipment connected to the rectifier. When the short circuit fault is cleared, the rectifier will automatically restore back to normal operation.
 - d. **High Voltage Shutdown:**
 1. Software settable HVSD level (from controller) 56 to 59 V. The software restart hysteresis is 0.5 V, ± 0.2 V.
 2. Back-up hardware HVSD (High Voltage Shut Down) at 59.5 V, ± 0.5 V.
 3. In the case of a second HVSD within 5 minutes (time value configurable via the controller) the unit shall require to be manually restarted. Method of manual restart: Reset the rectifier through the controller or remove the rectifier from the system and then re- install the rectifier into the system.
- **Over-Temperature Protection:** The rectifier provides over temperature protection by derating output power and recovers automatically.
- **Active Load Sharing:** The rectifier uses advanced digital active load sharing technology that maintains balancing to within 3% of rated current.
- **Hot Swappable:** The rectifier is designed to be plug-and-play. The rectifier can be inserted or removed from a live DC power system with no damage. When the rectifier is plugged into the system, the system output voltage will not be affected.
- **Cooling:** Each rectifier module contains a fan for front-to-back force air-cooling.
 - a. **Fan Fault Protection:** The rectifier module shuts down and its alarm indicator (red) flashes if the fan fails. Fan failure is detected and reported to Controller. The fan is field replaceable.
 - b. **Fan Control:** Fan speed is continuously variable. When input voltage is within normal range, the built-

in processor adjusts fan speed according to the rectifier module's internal temperature and output power. For example, a higher temperature or output power increases the fan speed. This feature can be disabled via the controller, allowing the fan to run at full speed regardless of temperature.

- **Paralleling:** Up to 32 rectifiers can be connected in parallel in one system.
- **Communication Failure:** The rectifier's protection indicator (yellow) will flash should it experience a communication failure. The failure information will be reported to the Controller and the Controller will process the failure accordingly. During a communication failure, in order to protect the battery, the rectifier output voltage will automatically be adjusted as follows. When used with the SCU+ Controller, rectifier output voltage goes to a default value (53.5 V, which can be modified using the SCU+ Controller). When used with the ACU+ Controller, rectifier output voltage goes to the ACU+ float voltage setting (this setting is stored in the rectifier). The rectifier will revert to normal operation once normal communication is restored.
- **Rectifier Output Current Imbalance:** When load sharing severe imbalance (output fuse open) and the output current drops to zero in average current >10% system, then the red fault indicator will illuminate.
- **Monitoring Function:** The rectifier has a built-in advanced DSP that monitors and controls the operation of the rectifier. The DSP also communicates with the Controller in real time through the CAN bus. Table 5 lists the different commands and information exchanged between the rectifier and the Controller.

Table 5. Exchange of Information between Rectifier and Controller

Commands / signals that can be received by the Rectifier Module from the Controller.	Information gathered by the Controller from the Rectifier Module.
<ul style="list-style-type: none"> • Turn On/Off • Current Walk-in On/Off • HVSD (High Voltage Shutdown) Reset • Current Limit Adjustment • Voltage Regulation 	<ul style="list-style-type: none"> • Input Voltage • Output Voltage • Output Current • Current Limit Setting • Temperature • Over Voltage Setting • On/Off Status • Fault Alarms, such as: HVSD Fan Fail • Protection Alarms, such as: Input Voltage Protection Inner DC Bus Voltage Protection High Temperature Protection • Thermal Derating • AC Derating • AC Fail • Imbalance Output Current • Address • Code • Date • Software Version • Hardware Version

Mechanical Specifications

- **Dimensions:**
 - a. **Millimeters:** 42.0 (Height) X 84.5 (Width) X 252.5 (Depth)
 - b. **Inches:** 1.7 (Height) X 3.3 (Width) X 9.9 (Depth)
- **Weight:** 1.13 kg (2.49 lbs)
- **Indicators:**
 - a. Power (Green LED)
 - b. Protection (Yellow LED)
 - c. Alarm (Red LED)

Operation

AC Input Protection Device Requirements/Recommendations

Refer to the system documentation supplied with the system the rectifier is installed in.

Local Indicators

Location and Identification: Refer to [Figure 5](#).

Description: There are three (3) indicators located on the rectifier's front panel. The functions of these indicators are as shown in [Table 6](#).

Note: *DC voltage must be present at the rectifier output terminals (from battery or an operating rectifier) or AC voltage at the input terminals.*

Rectifier High Voltage Shutdown and Lockout Restart

PROCEDURE

Remove the rectifier, wait 30 seconds or more (until the LEDs on the rectifier extinguish), then re-insert the rectifier.

The rectifier can also be restarted from the ACU+ LCD or WEB Interface menu (via the rectifier Reset command, found in the

Manual menu in the LCD menus or under the Rectifier Control Tab in the WEB Interface).

Rectifier Current Limit

When setting total rectifier current limit, the set point to each rectifier is the total set point divided by the number of rectifiers. For example, if the system contains five rectifiers and the current limit is set to 150 amps then each rectifier has a current limit set point of 30 amps. If one or more rectifiers are removed or fail it will take several seconds for the individual set points to the remaining rectifiers to be reset. In the example given, if one rectifier is removed the current limit set point will drop to 120 amps (30 amps times four remaining rectifiers) until the controller can send updated set points to the remaining rectifiers. This takes a couple communication cycles (several seconds) after which each rectifier would have a new set point of 37.5 amps for a total of 150 amps. The total current limit of the rectifiers should not be set such that the loss of the redundant rectifiers will cause this temporary set point to drop below the actual maximum expected load. If batteries are used on the rectifier output, the batteries should support the load until the current limit set points can be re-established due to loss of a rectifier.

Figure 5. Local Indicator Locations

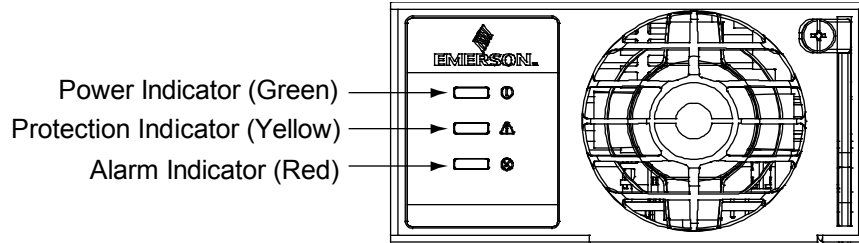

Table 6. Rectifier Module Indicators

Indicator		Normal State	Alarm State	Alarm Cause
	Power (Green)	On	Off	No input voltage. Internal input fuse open.
			Flashing	The rectifier module is being identified by the Controller.
	Protection (Yellow)	Off	On	AC input under/over voltage. PFC output under/over voltage. High temperature. Moderate load sharing imbalance. Rectifier modules are operating in an output power derating mode (rectifiers derate when module temperature rises above or input voltage falls below acceptable values).
			Flashing	Loss of communication with the Controller (the rectifier can provide power).
	Alarm (Red)	Off	On	Severe load sharing imbalance. Rectifier module output disabled for any reason, including overvoltage shutdown and internal output fuse open. Rectifier addresses contradictory.
			Flashing	Faulty fan (rectifier module shuts down).

Installing Rectifiers

Rectifier modules can be inserted or removed with power applied (hot swappable).

Note: Each rectifier module locks into a module mounting shelf by means of a latch located on the bottom of the module. The latch and rectifier module handle are interactive. Pushing the handle up into the module's front panel causes the latch to extend to the locking position; pulling the handle down out from the module's front panel causes the latch to retract. See Figure 6.



CAUTION! This rectifier module contains Double pole fusing; parts of the equipment that remain energized might represent a hazard during servicing after operation of the fuse. If the rectifiers are connected to a 3-phase system, the neutral line should also have a fuse.



WARNING! To prevent damage to the latching mechanism, ensure the handle is in the open position when installing or removing a rectifier module. NEVER hold the handle in the closed position when installing a rectifier module into a shelf.

PROCEDURE

Note: Refer to Figure 6 as this procedure is performed.

1. Unpack the module.
2. Place the module into an unoccupied mounting slot without sliding it in completely.
3. Loosen the captive screw on the module's handle. Pull the handle down out from the module's front panel (this will also retract the latch mechanism). See Figure 6.
4. Push the module completely into the shelf.
5. Push the handle up into the module's front panel. This will lock the module securely to the shelf. Tighten the captive screw on the handle.
6. Repeat the above steps for each rectifier module being installed in the system.
7. After the rectifier modules are physically installed in the mounting shelf(s), they are ready for operation immediately after power is supplied to them.
8. Certain functions (i.e. rectifier current limit, rectifier addressing) may require adjustment when adding or replacing a rectifier module. Refer to "Rectifier Current Limit" on page 8 and the Power System documentation for instructions.

Figure 6. Installing Rectifier Module

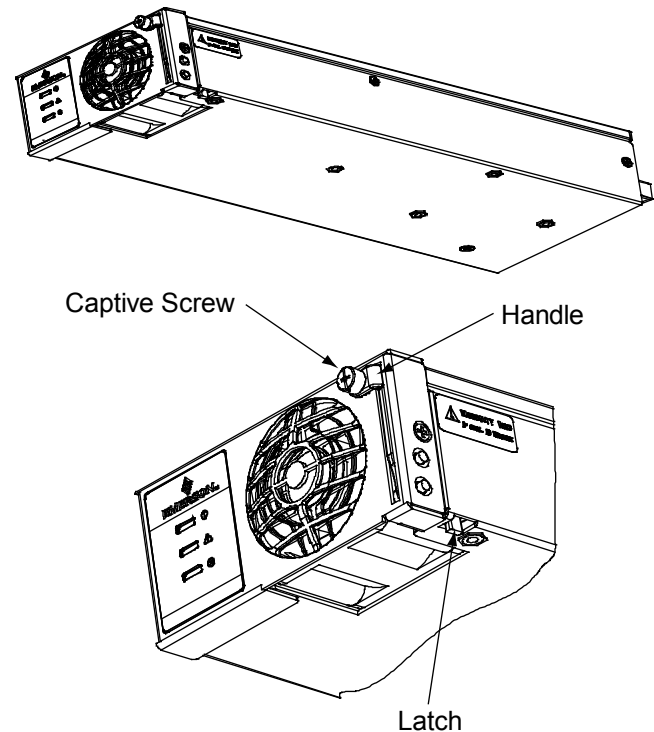

Troubleshooting and Repair

Troubleshooting

Rectifier Current Sharing Imbalance

When multiple rectifiers are operating in parallel and the load is greater than 10%, if the current sharing imbalance among them is greater than 3%, check if the rectifier is properly seated in the shelf.



If the current sharing imbalance still persists following the verification suggested above, replace the rectifier exhibiting the current imbalance.

Rectifier Fault Symptoms and Troubleshooting

The fault indicators that can be displayed by the rectifier are as follows. Refer to [Table 7](#) for a list of possible causes and corrective actions.

- Power Indicator (Green) Off
- Protection Indicator (Yellow) ON
- Protection Indicator (Yellow) Flashing
- Alarm Indicator (Red) ON
- Alarm Indicator (Red) Flashing

Table 7. Rectifier Module Troubleshooting

Symptom		Possible Cause(s)	Suggested Action(s)	
	Power Indicator (Green) Off	No input voltage.	Make sure there is input voltage.	
		Internal input fuse open.	Replace the rectifier module.	
	Protection Indicator (Yellow) On	AC input voltage outside the normal range.	Correct the AC input voltage to within the acceptable range.	
		PFC over voltage.	Replace the rectifier module.	
		Moderate load sharing imbalance.	Check if the rectifier module is properly seated in the shelf. If this does not correct the fault, replace the rectifier module.	
		Rectifier module not inserted into the slot completely.	Remove and properly insert the rectifier module.	
		Rectifier module over-temperature protection, which could be caused by:		
		1. Fan rotor blocked.	1. Remove any object that may be blocking the fan.	
		2. Ventilation blocked (inlet or outlet).	2. Remove any object that may be blocking the inlet or outlet.	
	3. Ambient temperature too high or rectifier module inlet too close to a heat source.	3. Lower the ambient temperature or relocate the heat source.		
Protection Indicator (Yellow) Flashing	Rectifier module communication failure.	Check the communication cables. Remove and properly insert the rectifier module.		
	Alarm Indicator (Red) On	Output over-voltage shutdown. Severe load sharing imbalance. Internal output fuse open.	Remove the rectifier module from its shelf and then reinstall after 30 seconds. If rectifier module fails to start or shuts down again; replace the rectifier module.	
		Rectifier module addresses contradictory.	Replace the rectifier module.	
	Alarm Indicator (Red) Flashing	Fan not operating (rectifier module shuts down).	Replace the fan.	

Replacement Procedures

Rectifier Module Replacement

Rectifier modules can be inserted or removed with power applied (hot swappable).

Note: Each rectifier module locks into a module mounting shelf by means of a latch located on the bottom of the module. The latch and rectifier module handle are interactive. Pushing the handle up into the module's front panel causes the latch to extend to the locking position; pulling the handle down out from the module's front panel causes the latch to retract. See [Figure 6](#).



DANGER! Take care when removing a rectifier module that was in operation, as rectifier module surfaces could be very hot.



WARNING! To prevent damage to the latching mechanism, ensure the handle is in the open position when installing or removing a rectifier module. NEVER hold the handle in the closed position when installing a rectifier module into a shelf.

PROCEDURE

Note: Refer to [Figure 6](#) as this procedure is performed.

1. Performing this procedure may activate external alarms. Do one of the following. If possible, disable these alarms. If these alarms cannot be easily disabled, notify the appropriate personnel to disregard any alarms associated with this system while this procedure is performed.
2. Loosen the captive screw on the module's handle. Pull the handle down out from the module's front panel (this will also retract the latch mechanism). See [Figure 6](#).
3. Grasp the handle and pull firmly to remove the module from the shelf.
4. Place the replacement rectifier module into the mounting position without sliding it in completely.
5. Loosen the captive screw on the module's handle. Pull the handle down out from the module's front panel (this will also retract the latch mechanism). See [Figure 6](#).
6. Push the module completely into the shelf.
7. Push the handle up into the module's front panel. This will lock the module securely to the shelf. Tighten the captive screw on the handle.
8. Certain functions (i.e. rectifier current limit, rectifier addressing) may require adjustment when adding or replacing a rectifier module. Refer to "Rectifier Current

Limit" on page 8 and the Power System documentation for instructions.

9. After the rectifier modules are physically installed in the mounting shelf(s), they are ready for operation immediately after power is supplied to them. Verify that the rectifiers are operating normally.
10. Enable the external alarms, or notify appropriate personnel that this procedure is finished.
11. Ensure that there are no local or remote alarms active on the system.

Rectifier Fan Replacement

Each rectifier uses a fan (P/N: 32010474) for cooling. If fan replacement should become necessary, perform the following procedure.

Refer to [Figure 7](#) as this procedure is performed.



WARNING! In a system with NO redundant rectifier, battery must have sufficient reserve to power the load(s) while the rectifier is removed for fan replacement.

Note: When performing any step in this procedure that requires removal of existing hardware, retain all hardware for use in subsequent steps.

PROCEDURE

1. Performing this procedure may activate external alarms. Do one of the following. If possible, disable these alarms. If these alarms cannot be easily disabled, notify the appropriate personnel to disregard any alarms associated with this system while this procedure is performed.
2. Remove the rectifier from the shelf. Refer to a previous procedure for step-by-step instructions.
3. Place the rectifier on a static-safe work surface. Connect an approved grounding strap to your wrist for the remainder of this procedure.
4. On this rectifier; remove the front panel by removing the three (3) screws securing the front panel to the chassis.
5. For proper orientation of the new fan, observe the location of the fan wires and the fan rotation and air flow arrows on the old fan.
6. Carefully remove the fan from the rectifier chassis and unplug the fan power cable from the printed circuit card.
7. Plug the power cable of the replacement fan into the connector on the printed circuit card. Carefully slide the replacement fan into the rectifier chassis (ensure the fan wires and fan rotation and air flow arrows match the orientation of the old fan).

8. Note that the fan has four holes in the front corners and that the faceplate has three tabs. Carefully slide the faceplate into position, aligning the fan holes with the faceplate tabs. Secure the faceplate to the rectifier chassis with the three (3) screws previously removed.
9. Replace the rectifier into the shelf. Refer to the previous procedure for step-by-step instructions.
10. When the fan starts, check to ensure that it is providing front-to-back airflow. If air direction is wrong, immediately remove the rectifier from the shelf. Repeat previous steps to check fan orientation, and correct as necessary. Reinstall the rectifier and again check for proper airflow.
11. Enable the external alarms, or notify appropriate personnel that this procedure is finished.
12. Ensure that there are no local or remote alarms active on the system.

Figure 7. Fan Replacement

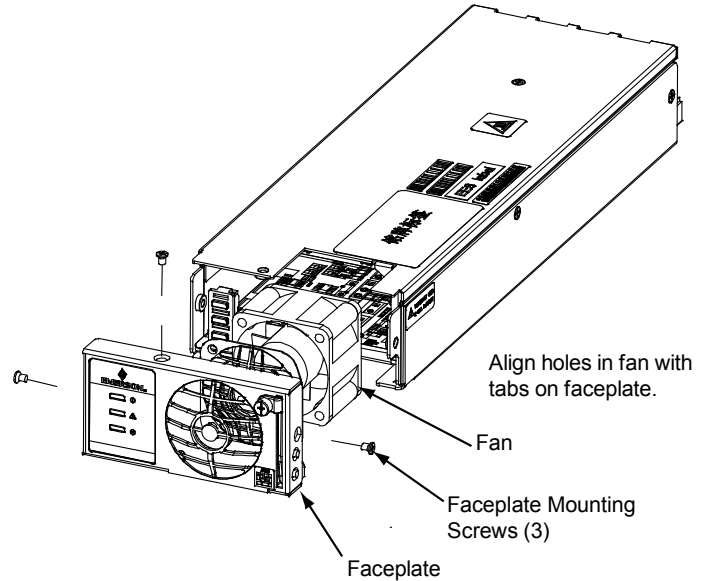

NetSure™ Rectifier Module

User Manual, UM1R482000E3 (Revision F, July 20, 2015)



The information contained in this document is subject to change without notice and may not be suitable for all applications. While every precaution has been taken to ensure the accuracy and completeness of this document, Emerson Network Power, Energy Systems, North America, Inc. assumes no responsibility and disclaims all liability for damages resulting from use of this information or for any errors or omissions. Refer to other local practices or building codes as applicable for the correct methods, tools, and materials to be used in performing procedures not specifically described in this document.

The products covered by this instruction manual are manufactured and/or sold by Emerson Network Power, Energy Systems, North America, Inc. This document is the property of Emerson Network Power, Energy Systems, North America, Inc. and contains confidential and proprietary information owned by Emerson Network Power, Energy Systems, North America, Inc. Any copying, use or disclosure of it without the written permission of Emerson Network Power, Energy Systems, North America, Inc. is strictly prohibited.

Names of companies and products are trademarks or registered trademarks of the respective companies. Any questions regarding usage of trademark names should be directed to the original manufacturer.

[EmersonNetworkPower.com/EnergySystems \(North America\)](http://EmersonNetworkPower.com/EnergySystems(NorthAmerica))
[EmersonNetworkPower.eu/EnergySystems \(EMEA\)](http://EmersonNetworkPower.eu/EnergySystems(EMEA))

© Emerson Network Power, Energy Systems, North America, Inc. 2015.

Business-Critical Continuity™, Emerson Network Power™, the Emerson Network Power logo, Emerson™ and Consider It Solved are service marks and trademarks of Emerson Electric Co. EnergyMaster™, eSure™, NetPerform™, NetReach™, NetSpan™, NetSure™ and NetXtend™ are trademarks of Emerson Network Power, Energy Systems, North America, Inc. Any other product, brand, or company names or logos are the property of the respective owner.

While every precaution has been taken to ensure accuracy and completeness herein, Emerson Electric Co. assumes no responsibility, and disclaims all liability, for damages resulting from use of this information or for any errors or omissions. Specifications subject to change without notice.

EMERSON. CONSIDER IT SOLVED.®