



## 564 SS Fireplace

- Operation
- Maintenance

Tested and Listed by



OMNI-Test Laboratories, Inc.  
Beaverton, Oregon  
Report # 028-F-80-5  
ANSI Z21.88a-2003

**WARNING:** If the information in these instructions is not followed exactly, a fire or explosion may result causing property damage, personal injury or loss of life.

- Do not store or use gasoline or other flammable vapors and liquids in the vicinity of this or any other appliance.

### WHAT TO DO IF YOU SMELL GAS

- Do not try to light any appliance.
- Do not touch any electrical switch; do not use any phone in your building.
- Immediately call gas supplier from a neighbor's phone. Follow the gas supplier's instructions.
- If you cannot reach your gas supplier, call the fire department.
- Installation and service must be performed by a qualified installer, service agency or the gas supplier.

This appliance may be installed as an OEM installation in a manufactured (mobile) home and must be installed in accordance with the manufacturer's instructions and the manufactured home construction and safety standard, Title 24 CFR, Part 3280.

This appliance is only for use with the type(s) of gas indicated on the rating plate. A conversion kit is supplied with the appliance.

# Owner's Manual



**TRAVIS INDUSTRIES  
HOUSE OF FIRE**

4800 Harbour Pointe Blvd. SW  
Mukilteo, WA 98275

## Introduction

We welcome you as a new owner of a 564 SS gas fireplace. This manual details operation and maintenance of this fireplace. Please familiarize yourself with the Owner's Manual before operating your heater and save the manual for future reference.

## Important Information

No other 564 SS gas fireplace has the same serial number as yours. The serial number is on the listing label that is chained to the gas control valve. This serial number may be needed in case you require service.

Model: 564 SS Fireplace

Serial Number: \_\_\_\_\_

Purchase Date: \_\_\_\_\_

Purchased From: \_\_\_\_\_

\_\_\_\_\_

\_\_\_\_\_

**Register your warranty online at:**

[traviswarranty.com](http://traviswarranty.com)

**Or, mail your warranty card to:**

Travis Industries House of Fire  
4800 Harbour Pointe Blvd. SW  
Mukilteo, WA 98275

**Save Your Bill of Sale.**

To receive full warranty coverage, you will need to show evidence of the date you purchased your heater. Do not mail your Bill of Sale to us.

We suggest that you attach your Bill of Sale to this page so that you will have all the information you need in one place should the need for service or information occur.

## Installation Warnings

- Installation requirements are printed in the **564 SS Installation Manual (part # 100-01188)**. All requirements in the installation manual must be met.
- Failure to follow all of the requirements may result in property damage, bodily injury, or even death.
- This heater must be installed by a qualified installer who has gone through a training program for the installation of direct vent gas appliances.
- This appliance must be installed in accordance with all local codes, if any; if not, follow ANSI Z223.1 and NFPA 54(88).
- In Manufactured or Mobile Homes must conform with Manufactured Home Construction and Safety Standard, Title 24 CFR, Part 3280, or, when such a standard is not applicable, the Standard for Manufactured Home Installations, ANSI/NCSBCS A225.1. This appliance may be installed in Manufactured Housing only after the home is site located.
- The fireplace is designed to operate on natural gas, or propane (LP).
- All exhaust gases must be vented outside the structure of the living-area. Combustion air is drawn from outside the living-area structure.
- Notify your insurance company before hooking up this fireplace.

## ***Table of Contents***

---

### **Introduction and Important Information**

Introduction..... 2  
 Important Information..... 2  
 Installation Warnings..... 2  
 Features..... 3  
 Heating Specifications..... 3

### **Safety Precautions**

Safety Precautions..... 4

### **Operation**

Before You Begin..... 6  
 Location of Controls..... 6  
 Starting The Pilot Flame..... 6  
 Starting the Fireplace for the First Time..... 8  
 Turning the Fireplace On and Off..... 8  
 Adjusting the Flame Height..... 8  
 Adjusting the Optional Blower Speed..... 9  
 Normal Operating Sounds..... 9  
 Normal Operating Odors..... 9

### **Maintenance**

Maintaining Your Fireplace's Appearance..... 10  
 Yearly Service Procedure..... 10  
 Grill Installation and Removal..... 11  
 Face Installation and Removal..... 12  
 Glass Frame Removal and Installation..... 13  
 Log Set Installation..... 15  
 Glass Cleaning..... 22  
 Troubleshooting Table..... 23  
 How this Fireplace Works..... 24  
 Wiring Diagram..... 25  
 Replacement Parts List..... 25

### **Warranty**

Warranty..... 24

### **Optional Equipment**

Optional Equipment List..... 27

### **Index**

Index..... 28

## ***Features***

---

- Works During Power Outages (millivolt system)
- Optional Thermostat or Remote Control
- Realistic "Wood Fire" Look
- Optional Blower for Effective Heat Distribution
- Convenient Operating Controls
- Variable-Rate Heat Output
- Low Maintenance

## ***Heating Specifications***

---

	<b>Natural Gas</b>	<b>Propane</b>
Approximate Heating Capacity (in square feet)*	950	950
Maximum BTU Input Per Hour	20,500	20,500
Minimum BTU Input on Low	5,100	4,200
Steady State Efficiency** (with blowers on)	76.5 %	74.2 %

\* Heating capacity will vary with floor plan, insulation, and outside temperature.

\*\* Efficiency rating is a product thermal efficiency rating determined under continuous operation independent of installed system.

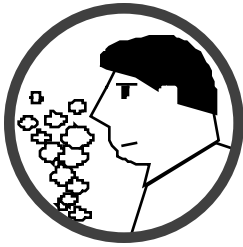
**IF YOU SMELL GAS:**

- \* Do not light any appliance
- \* Extinguish any open flame
- \* Do not touch any electrical switch or plug or unplug anything
- \* Open windows and vacate building
- \* Call gas supplier from neighbor's house, if not reached, call fire department



This unit must be installed by a qualified installer to prevent the possibility of an explosion. Your dealer will know the requirements in your area and can inform you of those people considered qualified. The room heater should be inspected and cleaned before use and at least annually by a qualified service person. More frequent cleaning may be required due to excessive lint from carpeting, bedding material, etc.

The instructions in this manual must be strictly adhered to. Do not use makeshift methods or compromise in the installation. Improper installation will void the warranty and safety listing.

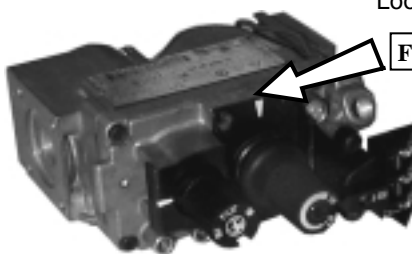

Look for this label:

**For LPG only | Pout 11" W.C.**

If the label is present, the heater is equipped for LP (propane). If the label is absent, the heater is equipped for NG (natural gas).

This heater is either approved for natural gas (NG) or for propane (LP). Burning the incorrect fuel will void the warranty and safety listing and may cause an extreme safety hazard. Direct questions about the type of fuel used to your dealer. Check the label and flame adjust knob on the gas control valve.



Contact your local building officials to obtain a permit and information on any installation restrictions or inspection requirements in your area. Notify your insurance company of this heater as well.



If the flame becomes sooty, dark orange in color, or extremely tall, do not operate the heater. Call your dealer and arrange for proper servicing.

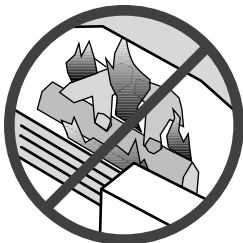

It is imperative that control compartments, screens, or circulating air passageways of the heater be kept clean and free of obstructions. These areas provide the air necessary for safe operation.



Do not operate the heater if it is not operating properly in any fashion or if you are uncertain. Call your dealer for a full explanation of your heater and what to expect.



Do not store or use gasoline or other flammable liquids in the vicinity of this heater.



Do not operate if any portion of the heater was submerged in water or if any corrosion occurs. Immediately call a qualified service technician to inspect the appliance and to replace any part of the control system and any gas control that has been under water.



Do not place clothing or other flammable items on or near the heater. Because this heater can be controlled by a thermostat there is a possibility of the heater turning on and igniting any items placed on or near it.

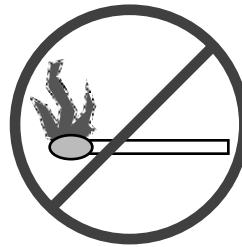

Light the heater using the built-in piezo igniter. Do not use matches or any other external device to light your heater.

Allow the heater to cool before carrying out any maintenance or cleaning.



The viewing glass should be opened only for lighting the pilot or conducting service. Do not operate with cracked, broken, or removed glass.

Any safety screen or guard removed for servicing must be replaced prior to operating the heater.

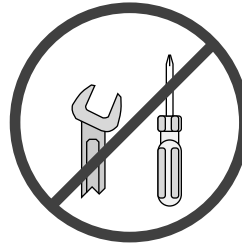

Never remove, replace, modify or substitute any part of the heater unless instructions are given in this manual. All other work must be done by a trained technician. Don't modify or replace orifices.



Operate the heater according to the instructions included in this manual.

If the main burners do not start correctly turn the gas off at the gas control valve and call your dealer for service.

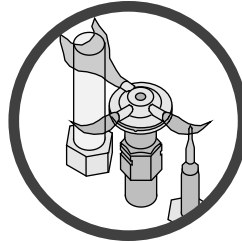

The pilot flame must contact the thermopile and thermocouple (see the illustration to the left). If it does not, turn the gas control valve to "OFF" and call your dealer.



This unit is not for use with solid fuel

Do not place anything inside the firebox (except the included fiber logs).

If the fiber logs become damaged, replace with Travis Industries log set.



Do not throw this manual away. This manual has important operating and maintenance instructions that you will need at a later time. Always follow the instructions in this manual.



Children and adults should be alerted to the hazards of high surface temperature and should stay away to avoid burns or clothing ignition. Young children should be supervised when they are in the same room as the heater.



**Travis Industries, Inc. grants no warranty, implied or stated, for the installation or maintenance of your heater, and assumes no responsibility of any consequential damage(s).**

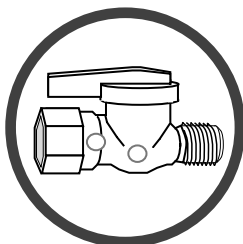

Instruct everyone in the house how to shut gas off to the appliance and at the gas main shutoff valve. The gas main shutoff valve is usually next to the gas meter or propane tank and requires a wrench to shut off.

## Before You Begin

- Read this entire manual before you use your new fireplace (especially the section "Safety Precautions" on pages 4 & 5). Failure to follow the instructions may result in property damage, bodily injury, or even death.

## Location of Controls

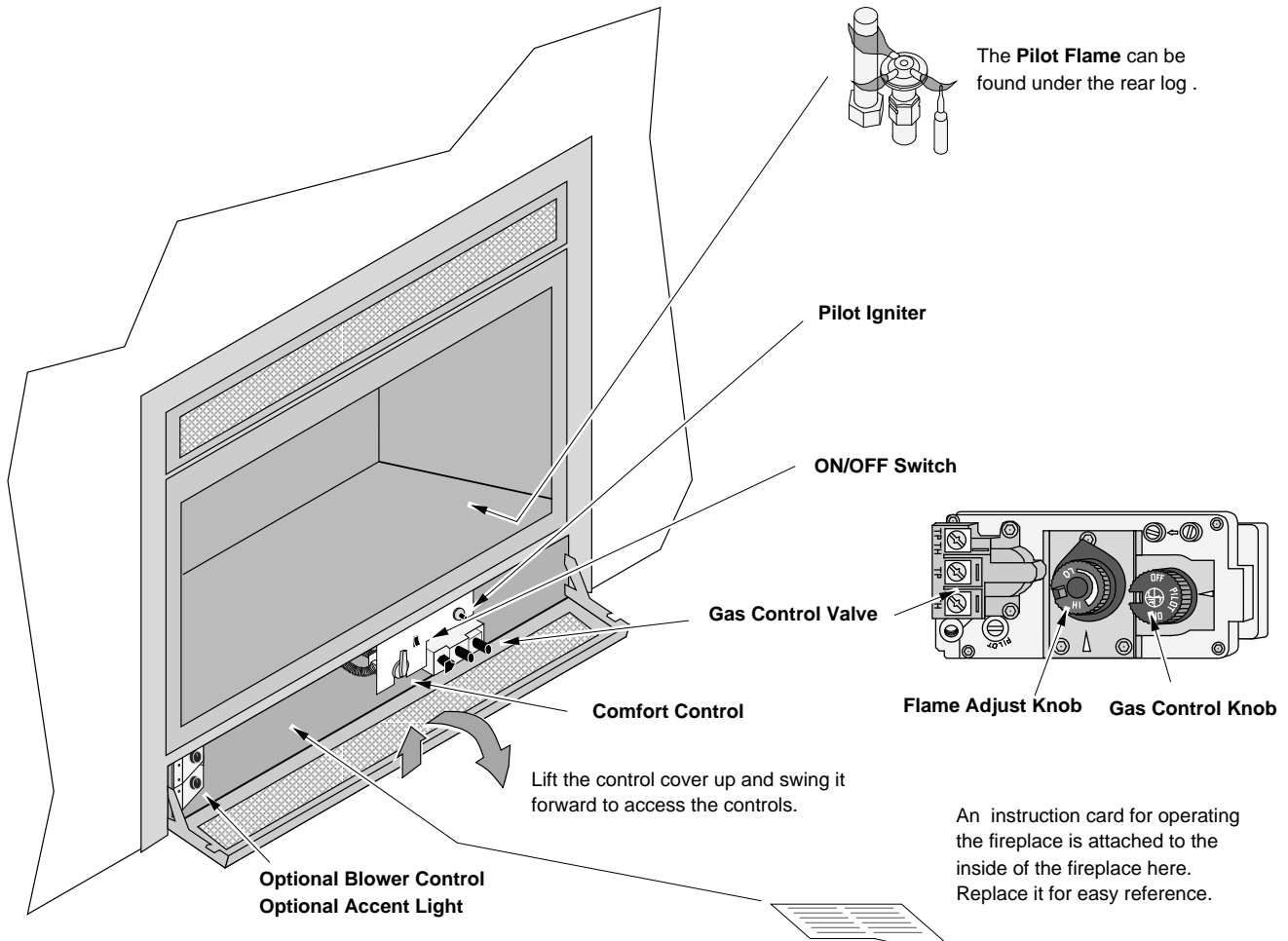

### Pilot Igniter

The pilot igniter is used only to start the pilot. When pressed, it sends an electrical charge to the pilot assembly. This creates a blue spark directly next to the pilot, igniting the pilot flame.

### On/Off Switch

This control is used to turn the fireplace burners on and off.

### Gas Control Knob

This knob is used to control gas to the fireplace and for starting the pilot. There are three positions, ON, OFF, & PILOT. The pointer to the left of the knob indicates the position this knob is in.

### Flame Adjust Knob

This knob controls the flame height from low ("LO") to high ("HI"). The pointer above the knob points to the position this knob is in.

### Comfort Control

This lever turns the rear burner on and off.  
NOTE: THIS IS NOT A SHUTOFF VALVE.

### Optional Blower Control

This knob controls the speed of the optional internal convection blower that pushes heated air into the room.

### Optional Accent Light

This knob controls the optional accent lights located behind the logs.

## Starting The Pilot Flame

The pilot flame is required to ignite the main burners (it also plays a safety role). It should be left on once lit. It will stay lit unless the gas control valve is turned to "OFF". However, the pilot will go out if the gas is shut off, the propane tank runs out (or low) or if the stove malfunctions. If the pilot turns off frequently, call your dealer for information. To start the pilot follow the directions below:

### **WARNING:**

**When lighting or re-lighting the pilot, the glass must be removed (see page 10).**

- a Remove the glass (see page 10 for details).
- b Push the gas control knob in slightly and turn it to the "OFF" position. The knob will not turn from "ON" to "OFF" unless the knob is depressed slightly. Wait five minutes to let any gas that may have accumulated inside the firebox escape. If you smell leaking gas, follow the directions on the cover "IF YOU SMELL GAS".
- c Turn the gas control knob to the "PILOT" position and press the knob in, this will allow gas to flow to the pilot light. Press the button on the pilot igniter repeatedly until you see the pilot light.

### **WARNING:**

**If the pilot does not light after 15 seconds, release the knob and call your dealer for service. Do not attempt to light pilot until service has been performed.**

### **NOTE:**

**You may wish to remove the log set to gain a better view of the pilot (see page 15).**

- d Keep the gas control knob depressed for 30 seconds once it is lit.
- e Release the gas control knob. If the pilot goes out, repeat step C. If the pilot refuses to stay lit, call your dealer for service. With the pilot lit, proceed to step "f".
- f Replace the glass.
- g Turn the gas control knob counter-clockwise to "ON". The pilot is now lit and the heater can be turned on and off.

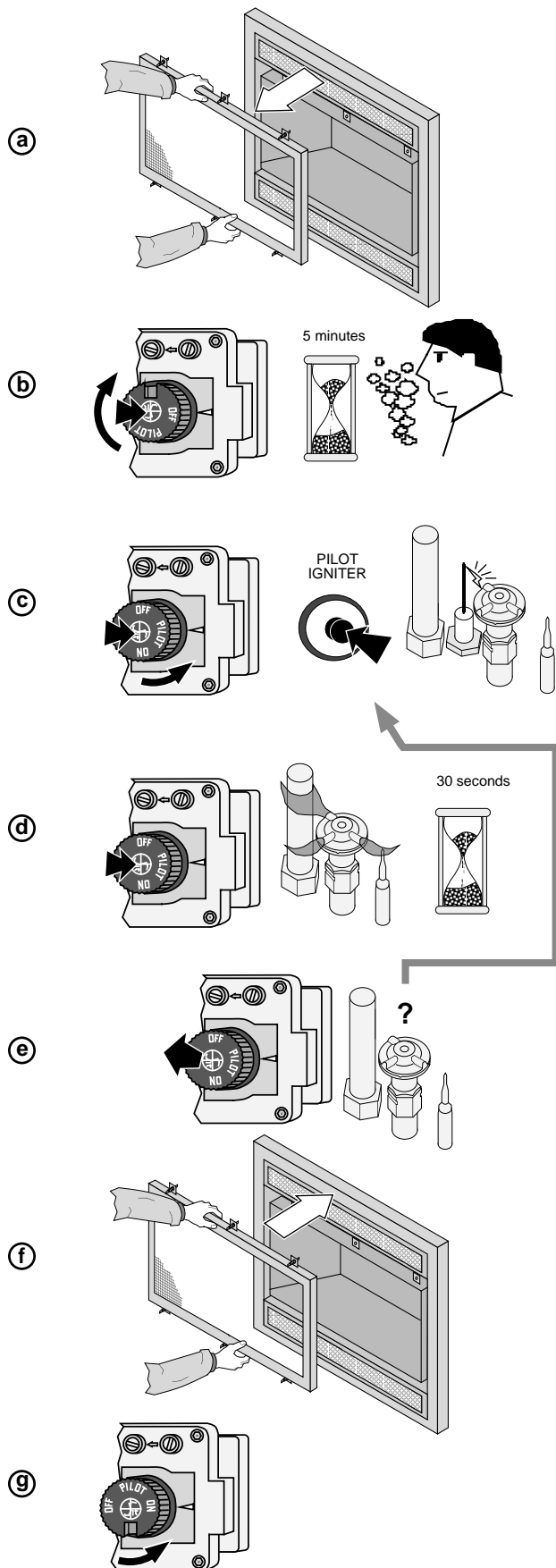



## Starting the Fireplace for the First Time

- Burn the heater at a high setting with the blower off for an extended period (up to 48 hours). This will cure the painted surfaces. **Fumes** from the paint curing and oil burning off the steel will occur. This is normal. We recommend opening a window to vent the room.
- **Condensation** may appear on the glass each time you start the fireplace - this is normal.
- **Blue Flames** will occur on the fireplace when it first comes on. After fifteen minutes the flames will turn a more realistic yellow and orange color.
- Certain installations use a remote "wall switch" to turn the fireplace on and off. If this is the case, leave the ON/OFF switch "ON".

## Turning the Fireplace On and Off

After the pilot has been started...



A switch is provided behind the control cover (below the firebox).

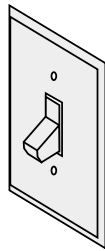

A wall switch may be used to turn the fireplace on and off.

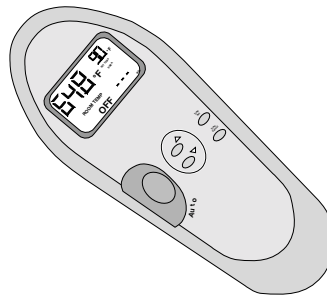

An optional remote may be used (see the instructions included with the remote).

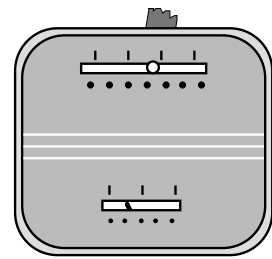

An optional wall thermostat may be used to control the temperature.

### **NOTE FOR REMOTES, THERMOSTATS, OR WALL SWITCHES:**

The on/off switch on the fireplace may be required to be left in the ON or OFF position for the fireplace to operate. Consult your installer or dealer for details.

- Do not place any combustible items on top of or directly in front of the fireplace, even temporarily. The optional thermostat may start the fireplace causing a combustible item to ignite.
- If the fireplace turns on and off frequently while using the thermostat, you may want to adjust the flame height down until it produces just enough heat needed.

## Adjusting the Flame Height

- Your fireplace has an adjustable flame to tailor the look and heat output to your specific needs. It is adjusted by turning the middle dial on the gas control valve.

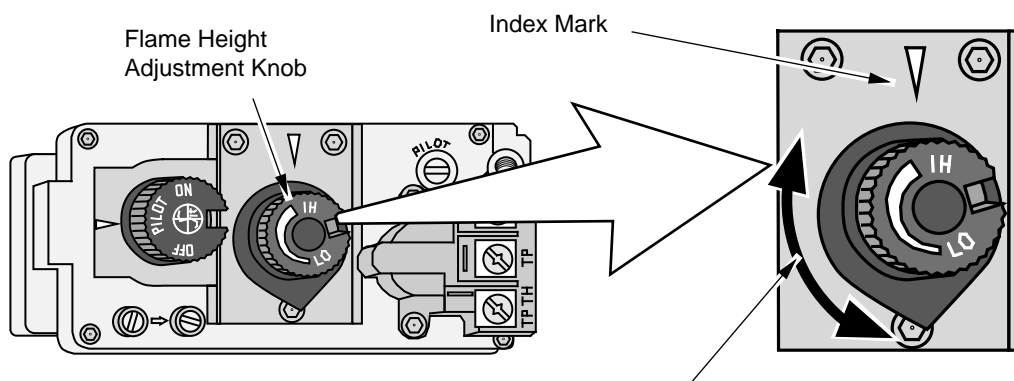

Turn counter-clockwise to adjust the flame higher, clockwise to lower.



## Adjusting the Optional Blower Speed

The blower helps transfer heat from the heater into the room. It will not turn on until the heater is up to temperature (approximately 10 minutes after starting). See the illustration below for instructions on adjusting the blower speed.

**NOTE:** With the rear burner off (comfort control), the heater may not become hot enough for the blower to turn on.

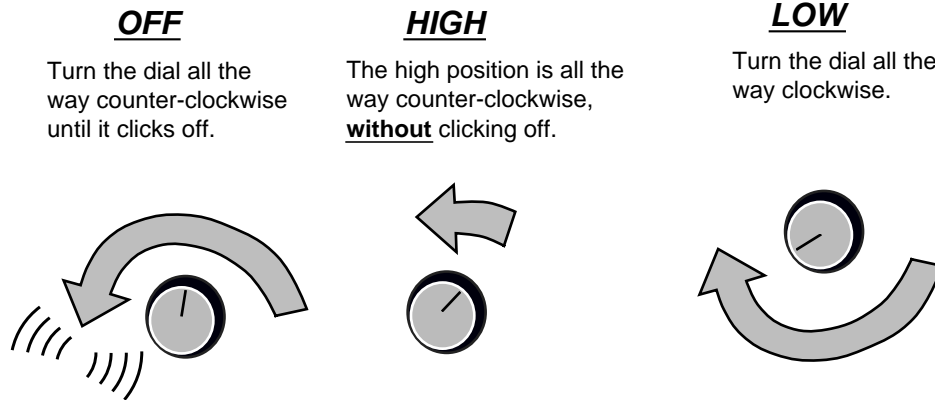

## Normal Operating Sounds

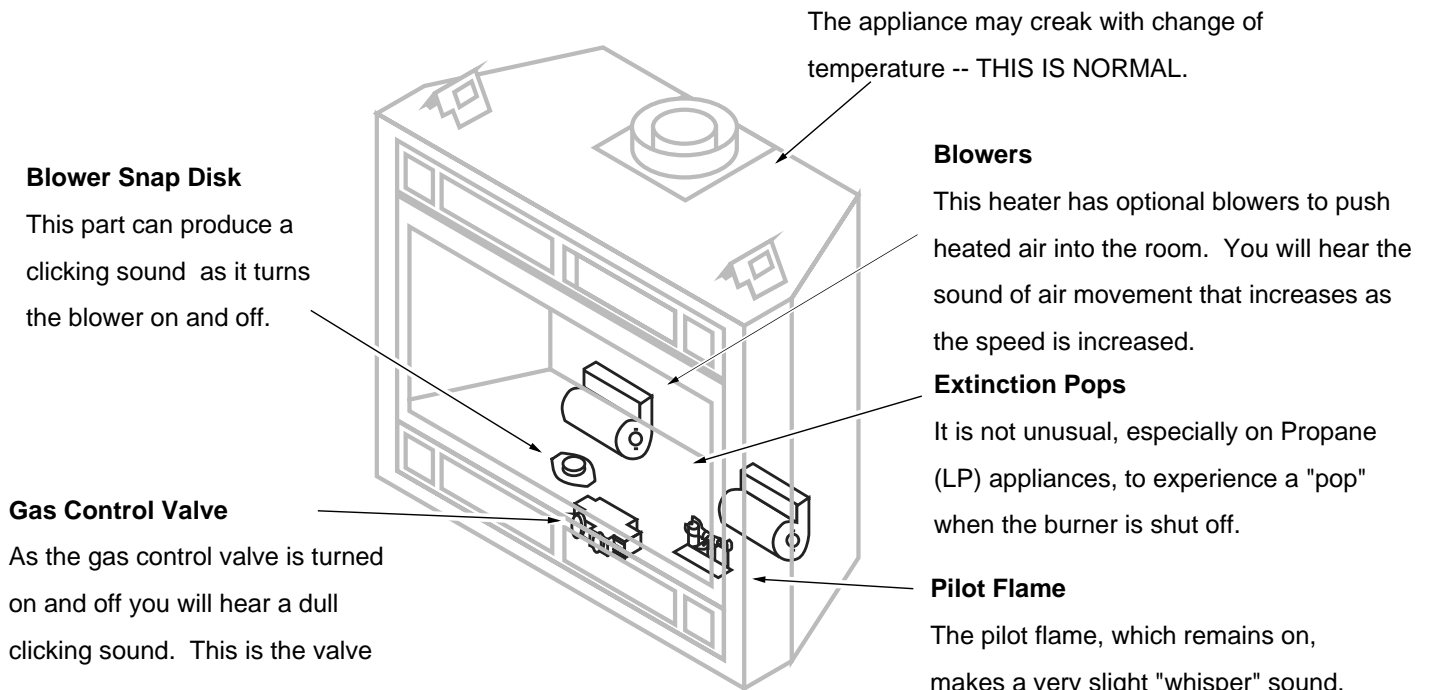

## Normal Operating Odors

This appliance has several areas that reach high temperatures. Dust or other particles on these areas may burn and create an odor. This is normal during start-up. You may notice the smell is more acute if the appliance was left idle for a long period.

## Maintaining Your Fireplace's Appearance

Fingerprints or other marks left on the optional plated surface may become etched in place if they are not wiped clean prior to turning the fireplace on. Clean the plated surface with denatured alcohol and a soft cloth (with the fireplace cool). Other cleaners may leave a film that may become etched into the surface.

## Yearly Service Procedure

- Failure to inspect and maintain the fireplace may lead to improper combustion and a potentially dangerous situation. We recommend the following procedures be done by a qualified technician.
1. Check the pilot flame. It should touch approximately 3/8" of the top of the thermopile and touch the top of the thermocouple (see illustration below). If it does not, contact your dealer for service.
  2. Shut off gas to the fireplace by turning the gas control knob to "OFF" (see step A under "Starting the Pilot" on page 7). Let the fireplace cool for 15 minutes. Remove the glass (see page 10).
  3. Remove the log set (**NOTE: the logs are very fragile** - see page 15). If severely deteriorated, replace. Check the logs for sooting. A small amount of soot along the bottom of the logs is normal. If excessive sooting is found, the fireplace will require adjustment. Contact your dealer.
  4. Inspect the burner and remove any debris.
    - Make sure the burner is not warped, cracked, or damaged.
    - Check the firebox and area around the pilot to make sure there is no warping or damage.
    - If any problem is found, discontinue use and contact your dealer for service.

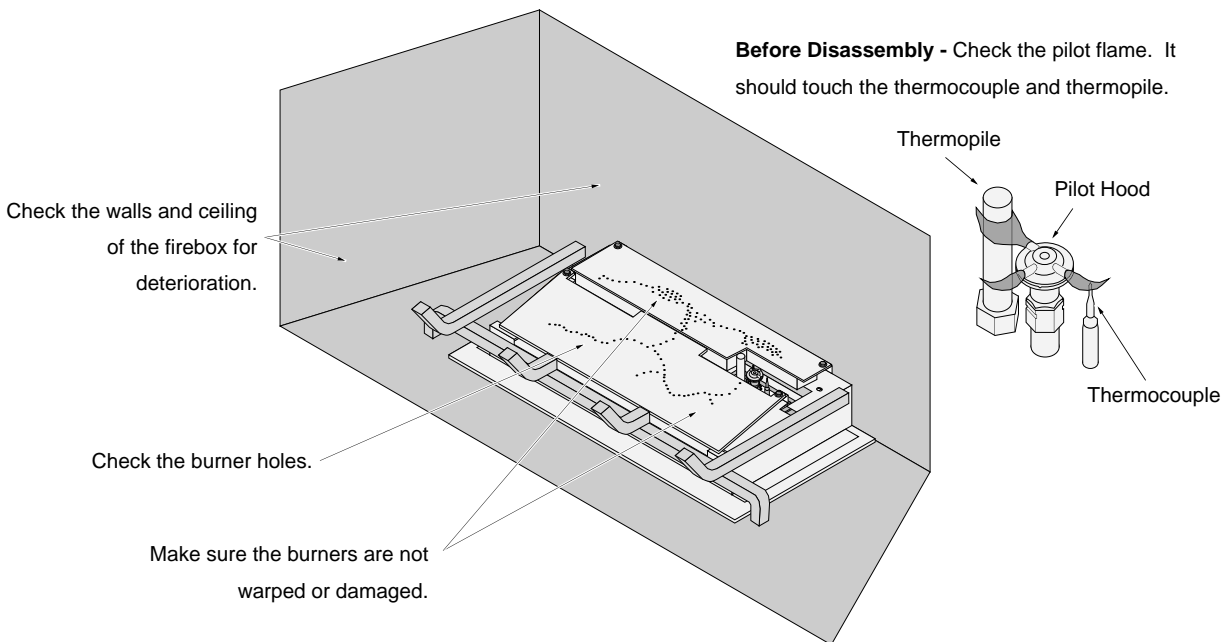

5. Replace the log set. Clean and replace the glass (see Glass Cleaning on page 22). If the glass is damaged, replace. Make sure the gasket along the perimeter of the glass contacts the face of the firebox and forms an air-tight seal. If it does not, re-align or replace the gasket to insure an air-tight seal.
6. Inspect the area behind the access door. Clean if necessary. Check the gas control valve and the gas lines. If damage is found, discontinue use and contact your dealer for service. Clean the air channels, ducts, and blower (if applicable).
7. Start the pilot and turn on the main burner. The flames should be orange/yellow and not touch the top of the firebox. If the pilot or main burners do not burn correctly, contact your dealer for service. Monitor the blower operation.
8. Remove any debris or vegetation near the vent termination. Contact your dealer if any sooting or deterioration is found near the vent termination.

## Grill Installation and Removal

Follow the directions below to install.

### Upper Grill Installation (FPX and Avalon)

Hold the grill at an angle and insert the lower slot over the lower bushing on the fireplace (both sides)

Swing the grill upwards to engage the upper slot. You will need to lift the grill slightly to get it over the bushing. Once in place the grill is held in place by gravity.

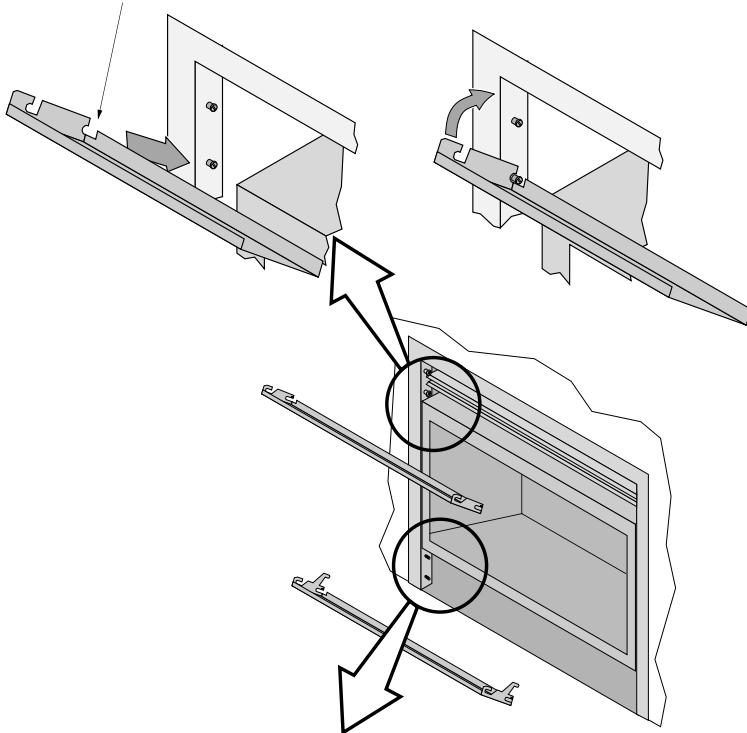

### Lower Grill Installation

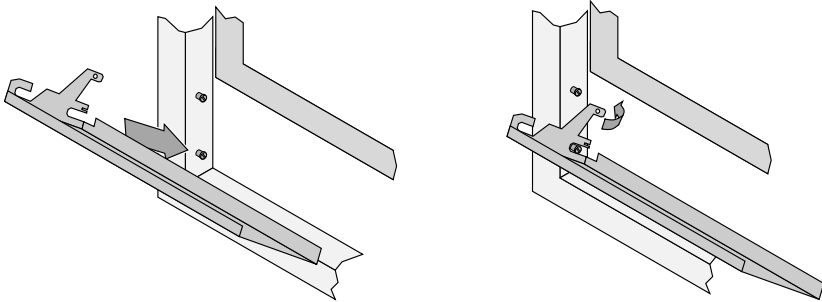

Hold the grill at an angle and insert the lower slot over the bushing on the fireplace (both sides). You may need press on the grill to get the tab over the bushing (this prevents the grill from accidentally falling off).

Bend the tab outward on both sides. This is the end-stop for the lower grill, it allows the grill to swing forward.

Swing the grill upwards to engage the upper slot. You will need to lift the grill slightly to get it over the bushing. Once in place the grill is held in place by gravity.

### Upper Grill Installation (Lopi)

**NOTE: The upper grill is difficult to install the first time - be patient, after you install it, you will know how it installs and it will be much easier the second time.**

#### SIDE VIEW

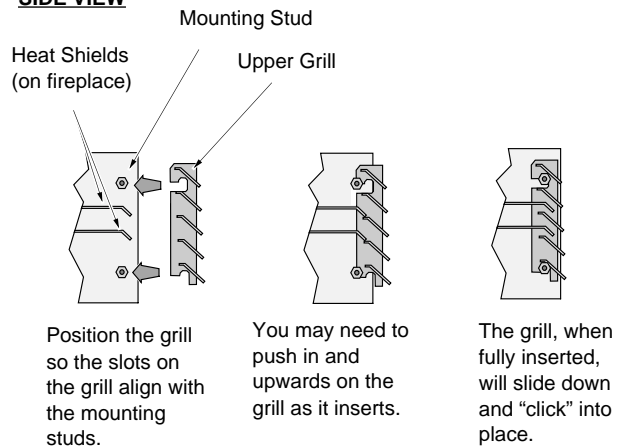

### Face Installation and Removal

Some fireplaces have a face that fits over the glass frame. The face can be removed following the directions below.

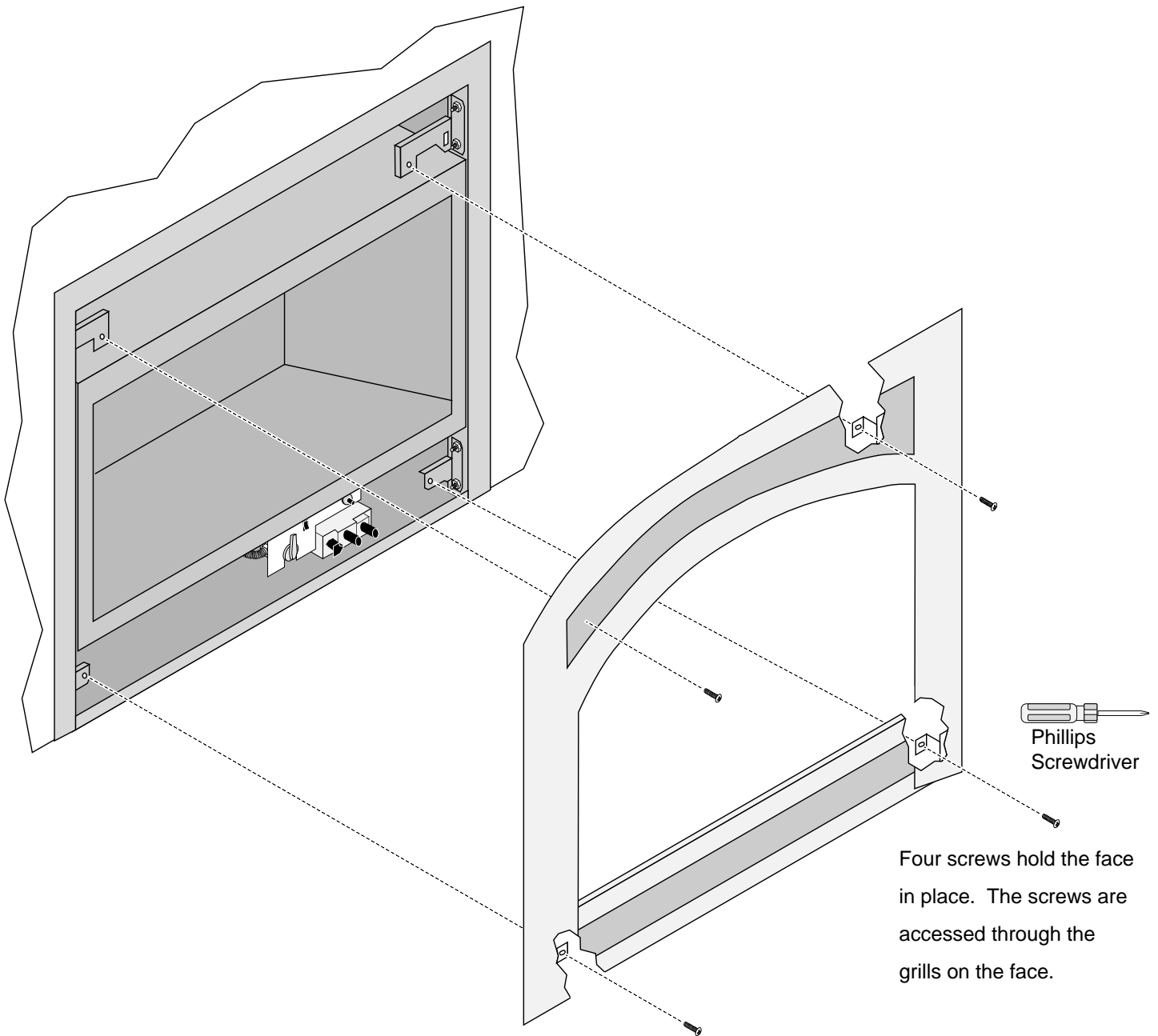

## Glass Frame Removal and Installation

**Warning:** The appliance must be completely cool before removing the glass.

**Warning:** Do not strike or slam the glass.

- a** Based upon the face being used, either:
- swing the access door down and remove the top grill,
  - remove the face (unscrew or lift off - see the instructions included with the face for details).

Open the four latches holding the glass frame in place (start with the bottom three) - follow the directions shown to the right.

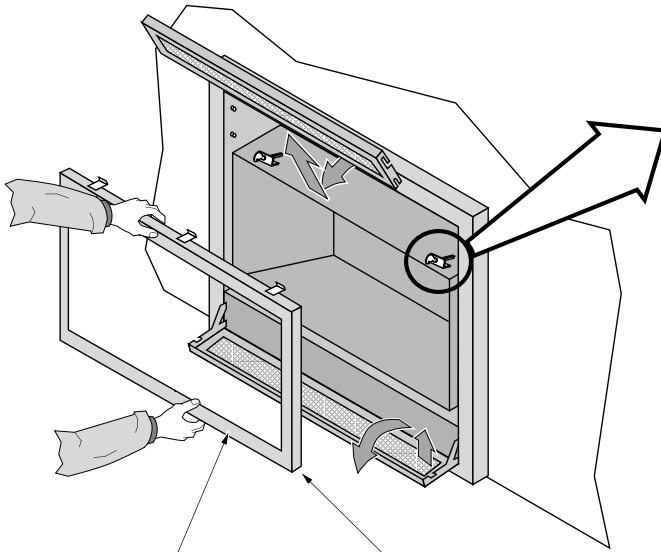

- b** Lift the glass frame up and pull it forward to remove.

**NOTE:**

You may need to lift the glass frame while re-attaching.

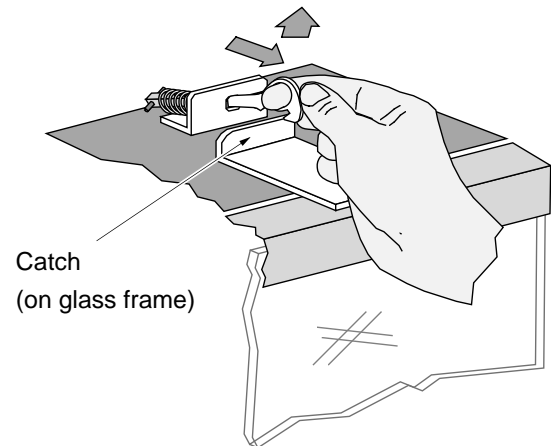
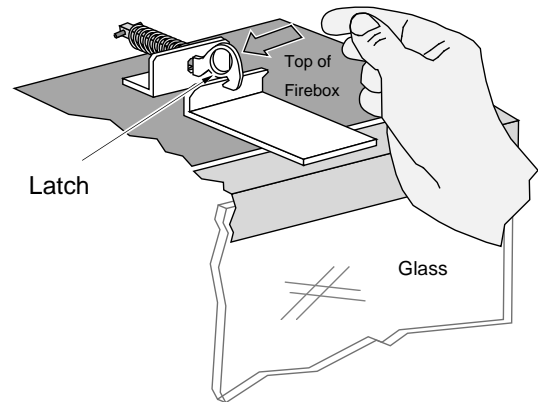

**Re-Attaching the Glass Frame:**

- Hang the glass frame on the firebox.
- While holding in place, attach the upper latches (follow the instructions to the right in reverse).
- Lift the glass frame slightly and attach the lower latches.

**NOTE:** Make sure the glass frame is all the way in place - it should be flush with the front of the fireplace when installed.

***Glass Frame Removal and Installation (continued)***

The latch can come loose from the latch assembly. This occurs only when it is rotated. Follow the directions below to re-install the latch if it comes loose.

Hold the latch at an angle and insert it into the slot on the glass frame anchor.

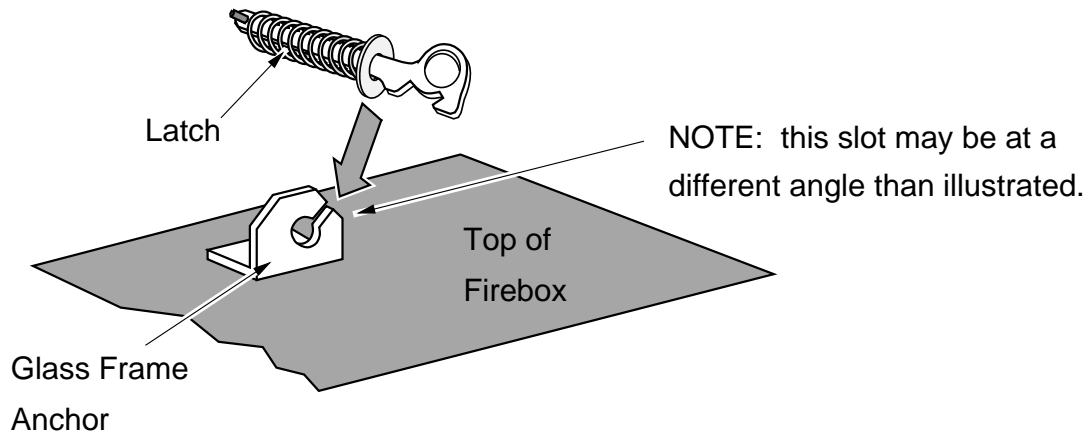

Note how the washer on the latch fits behind the flange on the glass frame anchor.

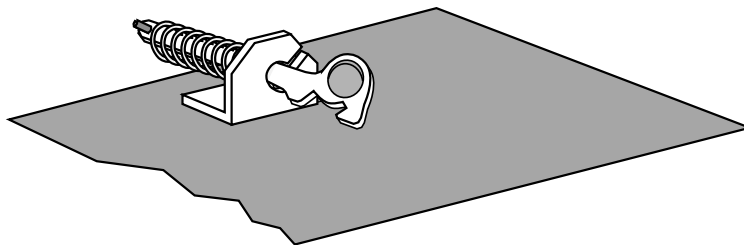

Once fully inserted, turn the latch until it is upright.

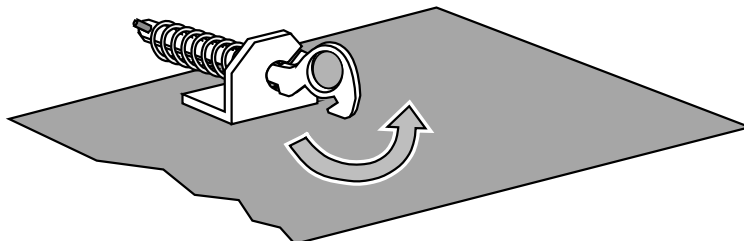

***Log Set Installation***

**Log Set Overview**

When installed, the logs should appear as shown below.

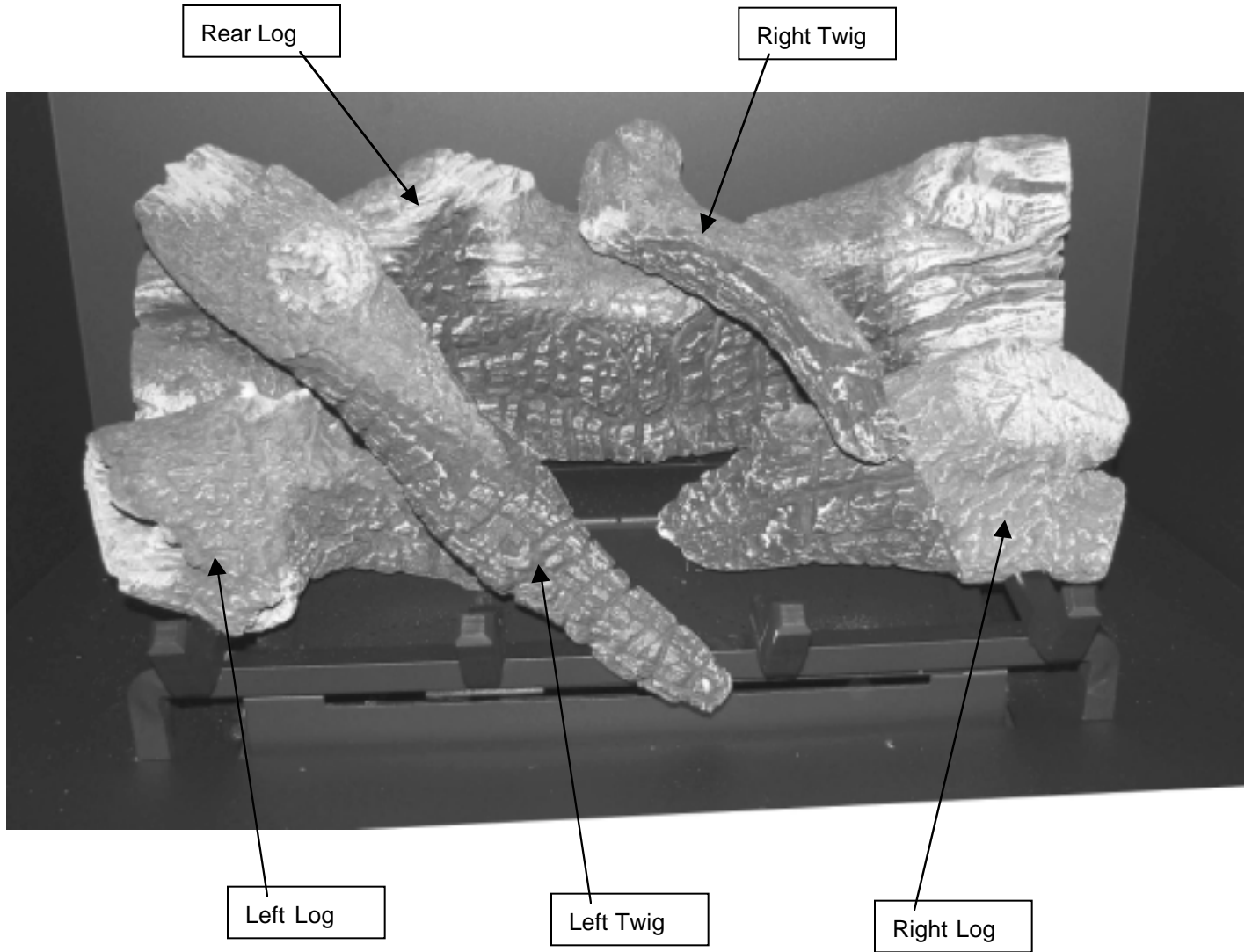



## Rear Log Installation

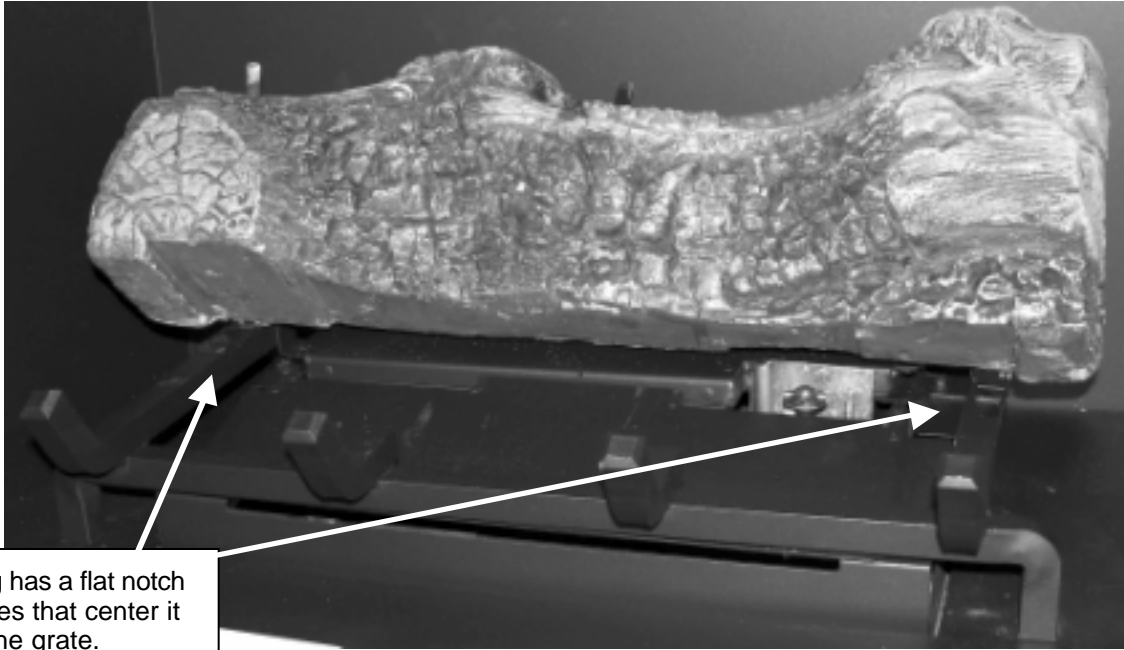

The rear log has a flat notch on both sides that center it on the grate.

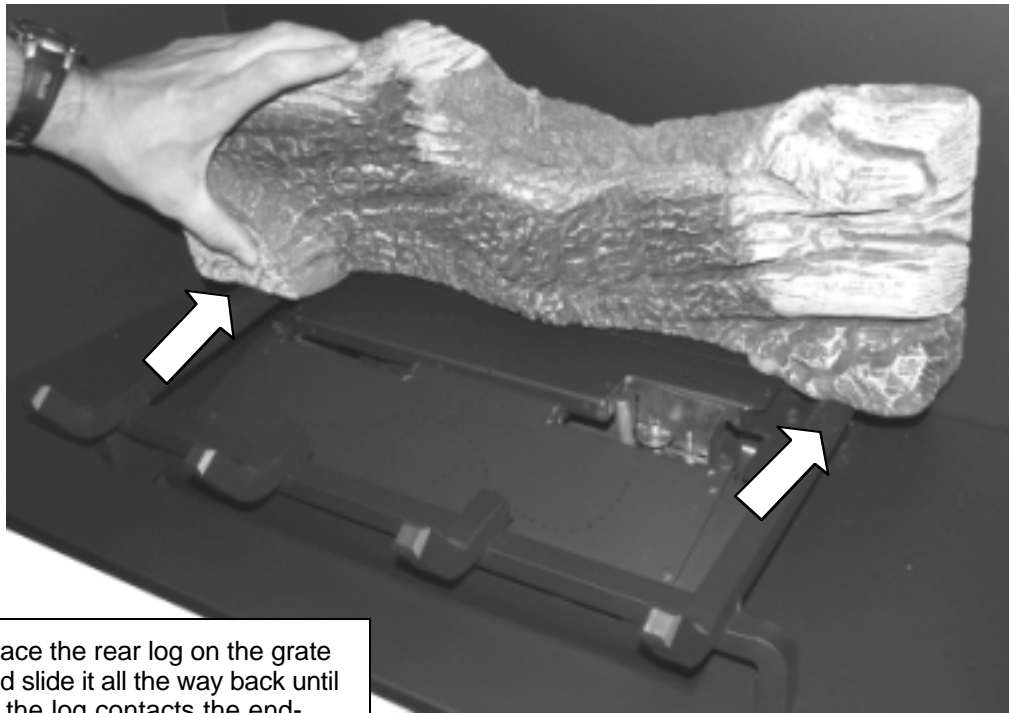

Place the rear log on the grate and slide it all the way back until the log contacts the end-brackets on the grate.

## Right Log Installation

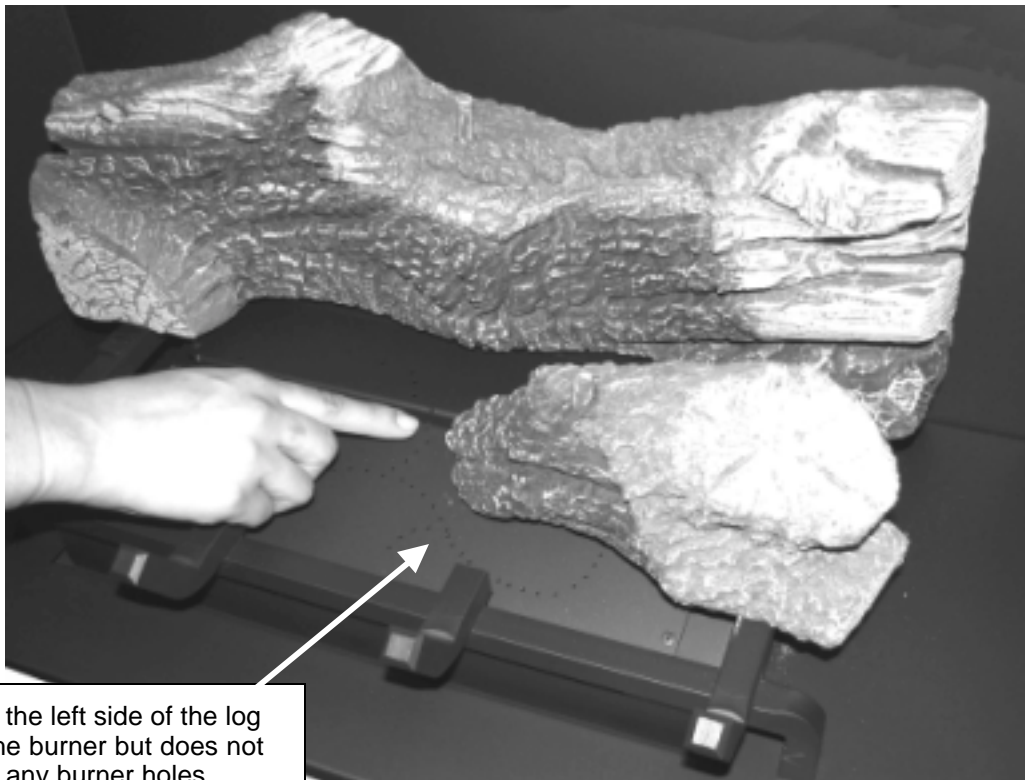
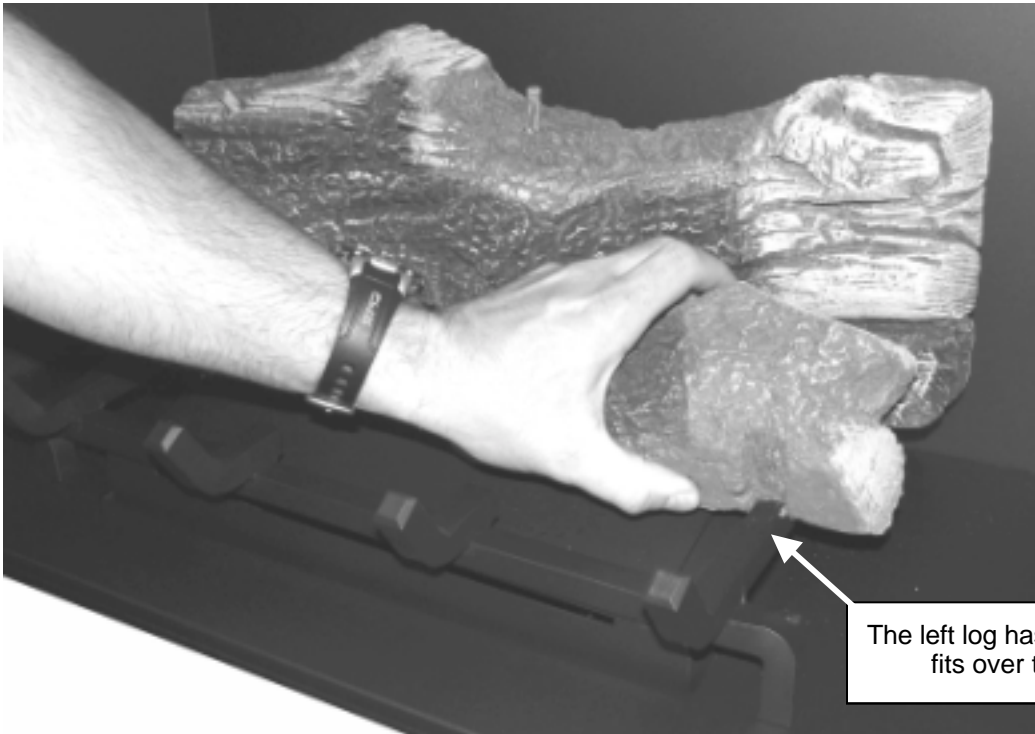

## Left Log Installation

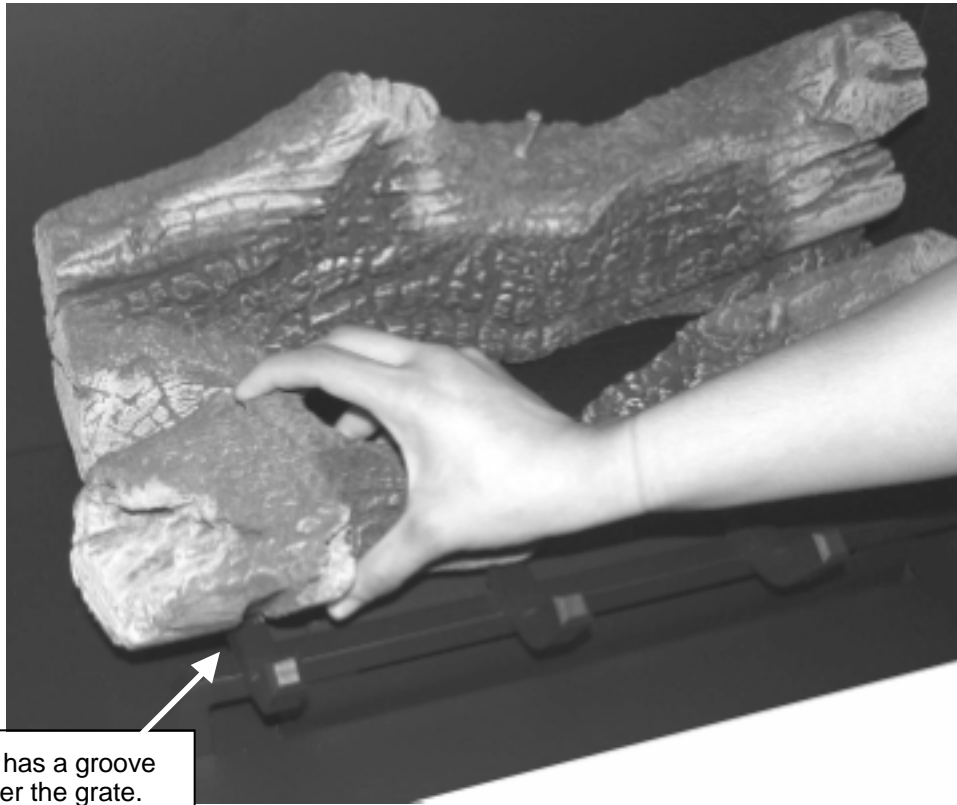

The left log has a groove that fits over the grate.

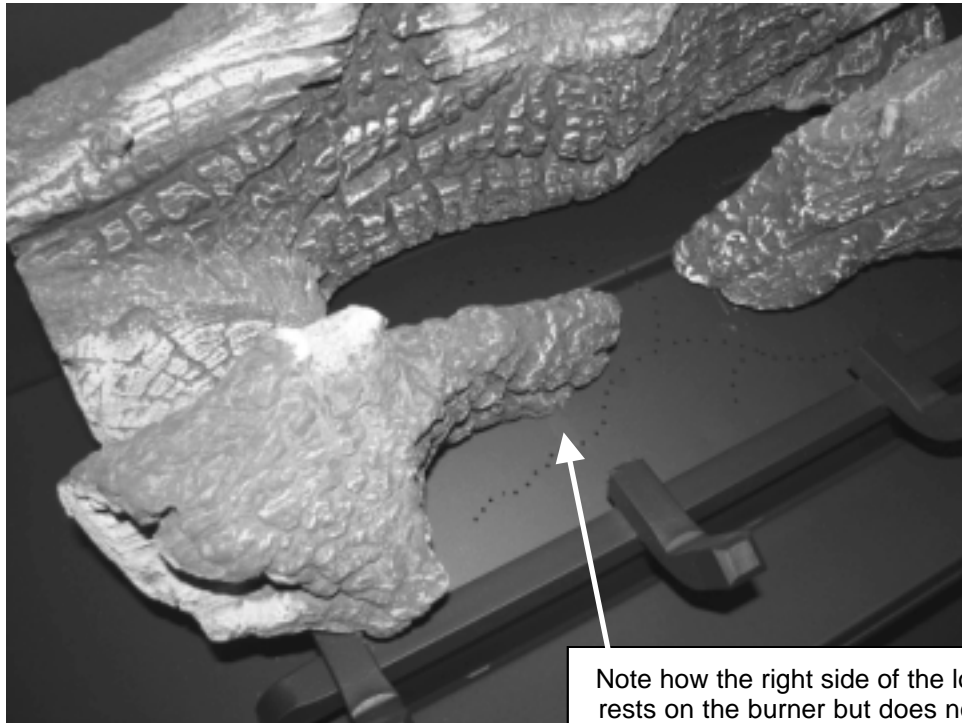

Note how the right side of the log rests on the burner but does not cover any burner holes.

## Left Twig Installation

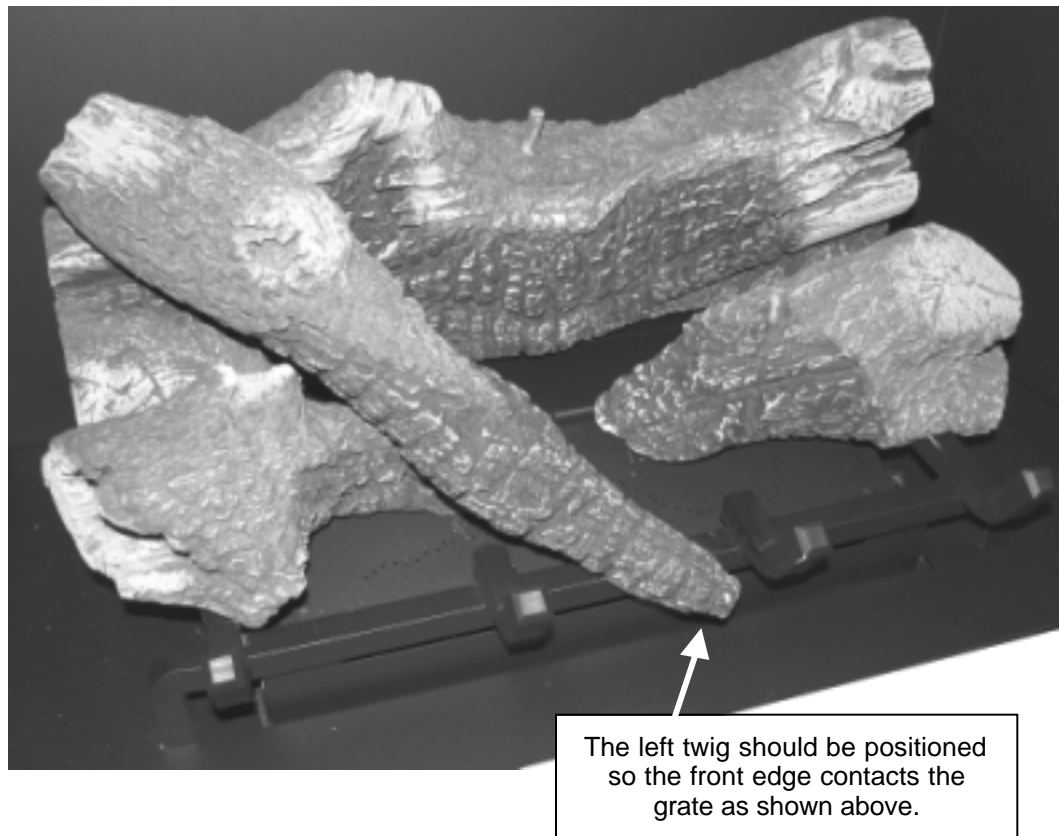
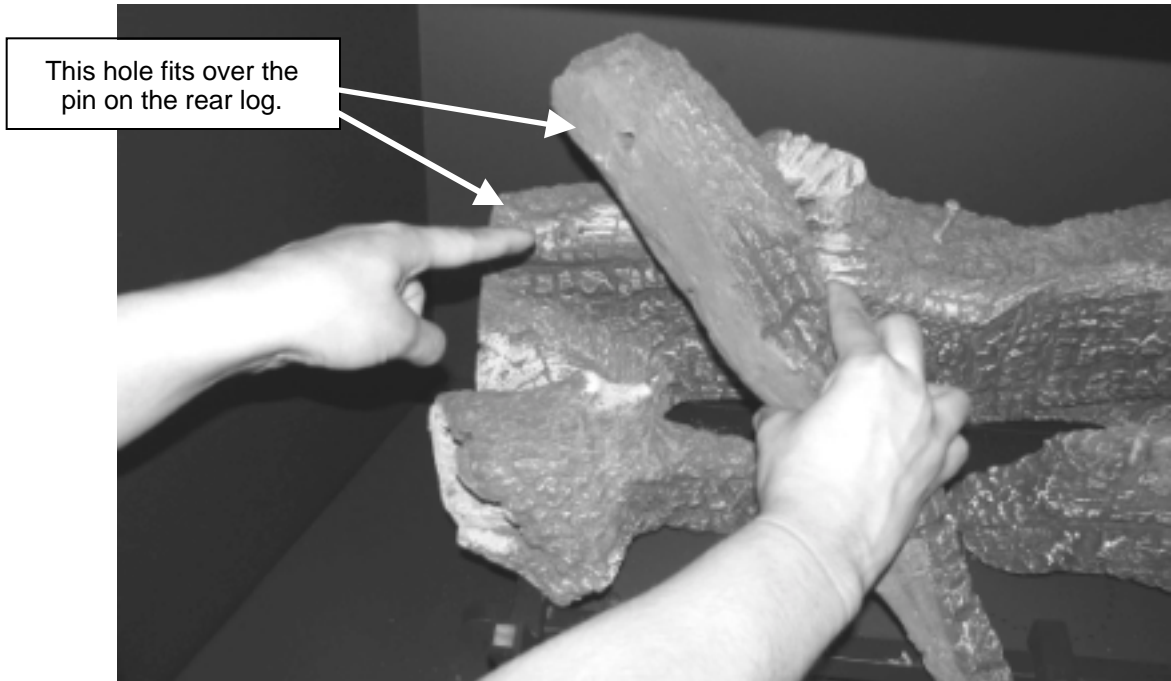



## Right Twig Installation

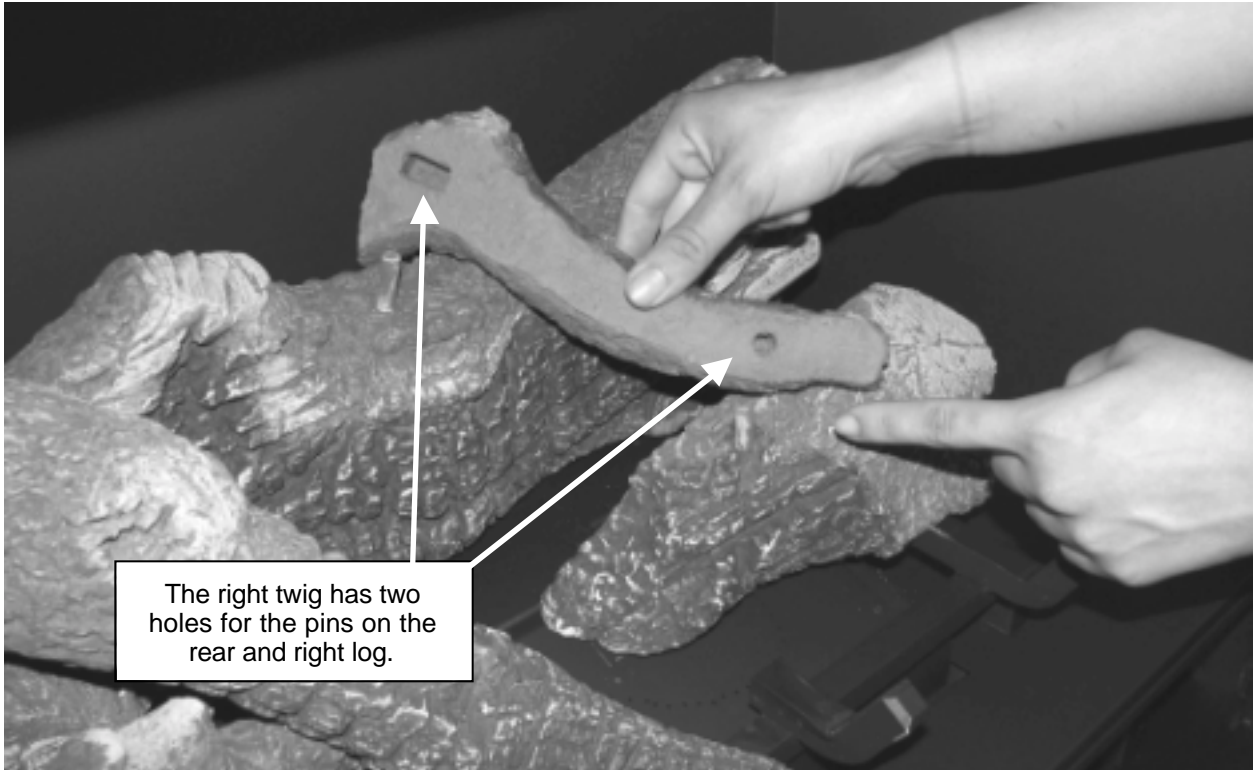

## Ember Installation

A bag of embers is provided to further enhance the firebox. Place the embers on the firebox floor and on the burner. Do not place embers over any of the burner holes or air channels.



## Glass Cleaning

The glass may be cleaned with a non-abrasive cleaner. To clean the inside of the glass, simply remove the glass frame, place it on a non-scratching surface, and clean the inside surface.

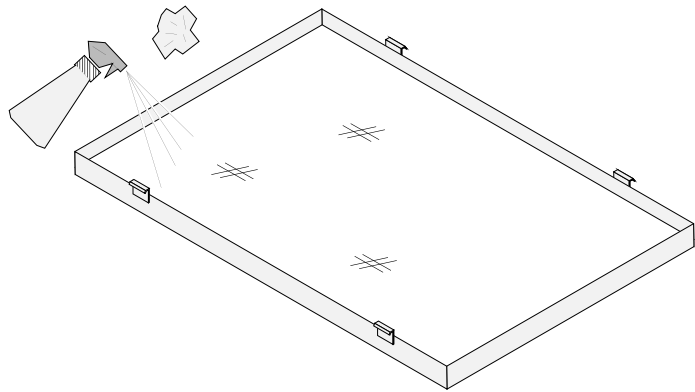

If the outside surface of the glass frame requires cleaning, follow the directions below to remove the outer glass frame and screen.

**WARNING:** do not operate the fireplace without the glass frame and screen in place.

Six sets of tabs hold the glass (and glass gasket) in place. Four of these tabs are at the corners, two are at the top and bottom of the glass frame.

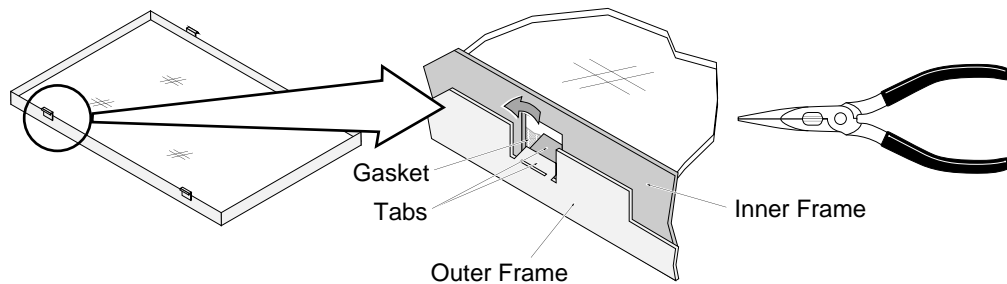

**REMOVAL INSTRUCTIONS:** carefully bend the tabs out with needle-nose pliers (there are tabs on the inner and outer frame - the center tabs only have tabs on the inner frame). Do not pry these tabs, this may cause the glass to crack.

**REPLACEMENT INSTRUCTIONS:** carefully bend the tabs inward, making sure the tabs contact the gasket, not the glass. Bend the tab inwards 30°- do not over-bend the tabs.

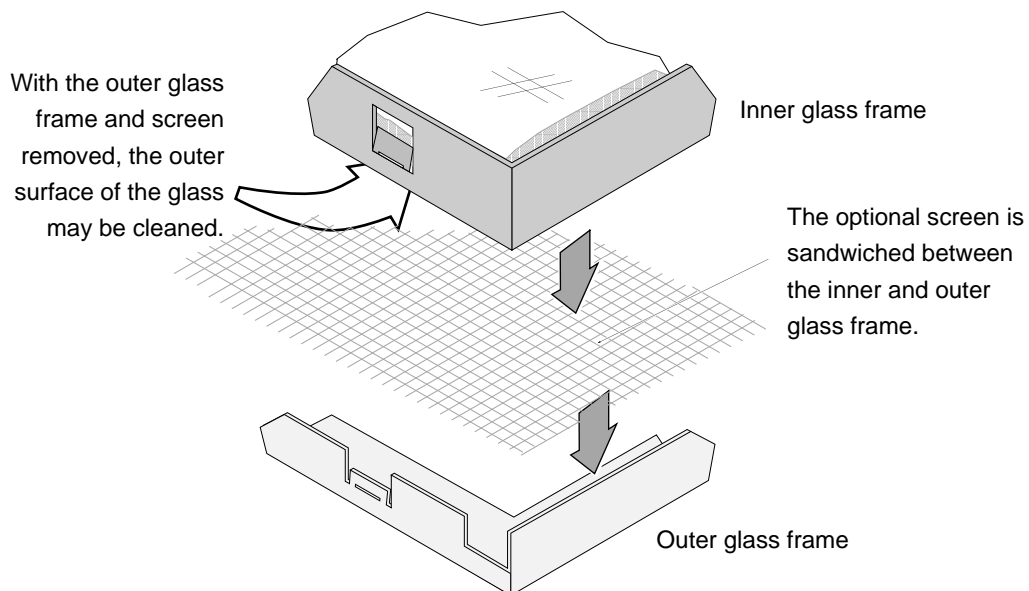



**Troubleshooting Table**

<b>Problem:</b>	<b>Possible Cause:</b>	<b>Don't Call for Service Until You:</b>
<b>Pilot Will Not Light</b>	A gas shut off valve is turned off ..... The gas control knob isn't turned to "PILOT" ..... The valve control knob isn't pushed in ..... The igniter wasn't pressed repeatedly ..... No Propane in Tank .....	Check all gas shut off valves See "Starting the Pilot Light" Step C See "Starting the Pilot Light" Step C See "Starting the Pilot Light" Step C Check Tank Level
<b>Main Burners Will Not Start</b>	The pilot light has gone out ..... The gas control valve is turned to "PILOT" or "OFF" The ON/OFF switch is turned to "OFF" ..... The remote control is not working correctly ..... The thermostat is disconnected or set too low .....	See "Starting the Pilot Light" See "Starting the Pilot Light" Turn the ON/OFF switch to "ON" See the remote control instructions See "Thermostat Operation"
<b>Remote Control Does Not Work</b>	The pilot light has gone out ..... The gas control valve is turned to "PILOT" or "OFF" The ON/OFF switch is turned to "OFF" ..... The remote is too far away from the fireplace ..... The remote control receiver is turned "Off" ..... One of the two remote control batteries is dead .....	See "Starting the Pilot Light" See "Starting the Pilot Light" Turn the ON/OFF switch to "ON" Use the remote closer to the fireplace See the remote control instructions See the remote control instructions
<b>Thermostat Does Not Work</b>	The pilot light has gone out ..... The gas control valve is turned to "PILOT" or "OFF" The ON/OFF switch is turned to "OFF" ..... The thermostat is set too low .....	See "Starting the Pilot Light" See "Starting the Pilot Light" Turn the ON/OFF switch to "ON" See "Thermostat Operation"
<b>Fireplace Will Not Distribute Heat</b>	The fireplace is not getting electricity ..... The fireplace is not up to temperature .....	Check the breaker switch See "Operating Your Fireplace"
<b>Pilot Goes Out Intermittently</b>	The gas supply has been shut off .....	Keep the gas supply turned on
<b>Flames Are Too Blue</b>	The fireplace has just been started ..... Improper air shutter adjustment .....	This is normal - see "Starting the Fireplace for the First Time" Adjust Air Shutter - contact your dealer
<b>Flames Are Too Short (Under 6")</b>	The flame height may be turned too low .....	Turn the flame height to "HI" - See "Adjusting the Flame Height"
<b>Thin Layer of Soot Covers the Glass</b>	The logs or coals are placed incorrectly ..... Improper air shutter adjustment .....	See "Log Set Installation" Adjust Air Shutter - contact your dealer

## How this Fireplace Works

This fireplace was designed with safety as the primary concern. Many of the components inside this fireplace are for safety purposes. Therefore, only certified gas service technicians should service this fireplace.

### What Turns the Main Burners On and Off

This fireplace uses a millivolt system to control its operation (a millivolt is a very small amount of electricity). The thermopile and thermocouple generate electricity when heated by the pilot flame. This electricity is used to operate the gas valve. Without enough electricity, the gas valve will not turn on. That is why when starting the pilot the gas control knob has to be pressed in long enough for the thermocouple to heat up and generate enough electricity. The thermopile provides power for the ON/OFF switch, remote control, or thermostat (see the illustration below). Because the thermopile generates the electricity needed to turn the fireplace on and off, this fireplace can be operated when the power is out (although the blower will not run).

When heated, the thermopile generates electricity (a very small amount measured in "Millivolts").

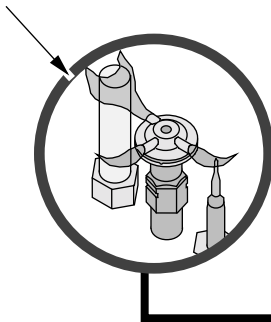

This electricity is used to operate the main burners.

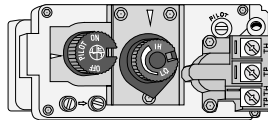

The main burners are switched on and off using the electricity generated by the thermopile. The ON/OFF switch, remote control, or thermostat control the circuit to the main burner.

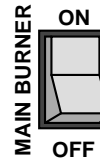
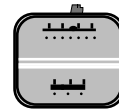
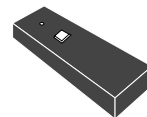

### What Prevents Gas Buildup

This appliance utilizes a high-technology gas valve in conjunction with a pilot flame to ensure no gas builds up inside the firebox.

The thermocouple (next to the pilot) senses when the pilot flame is lit. If the pilot flame goes out, this thermocouple no longer generates electricity, causing the gas valve to automatically shut off all gas to the heater, preventing the pilot from spilling gas into the firebox.

#### Pilot Flame

The pilot flame is a time-proven component that eliminates the possibility of gas buildup inside the firebox.

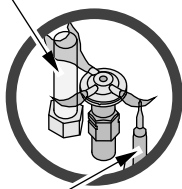

#### Thermocouple

The thermocouple generates a small amount of electricity. If the pilot flame goes out, the gas valve automatically shuts off all gas.

#### Gas Valve

This high-technology valve automatically shuts off all gas if it does not receive a signal from the thermocouple. If any component is damaged or sensing a malfunction, or if the wiring is damaged, it will shut off all gas.

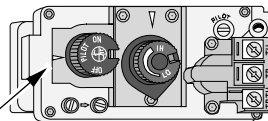

#### External Shut Off Valve

This valve is placed on the gas line to shut off gas to the appliance during maintenance procedures.

## Wiring Diagram

### Millivolt Wiring (stock configuration)

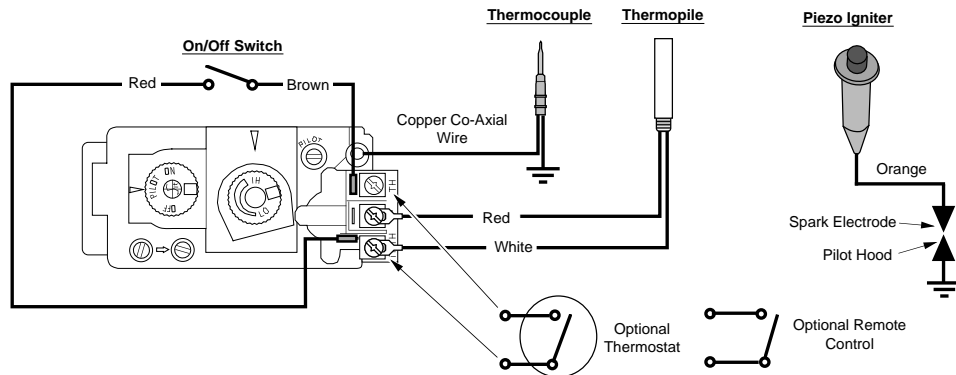

### Optional Blower Wiring Harness

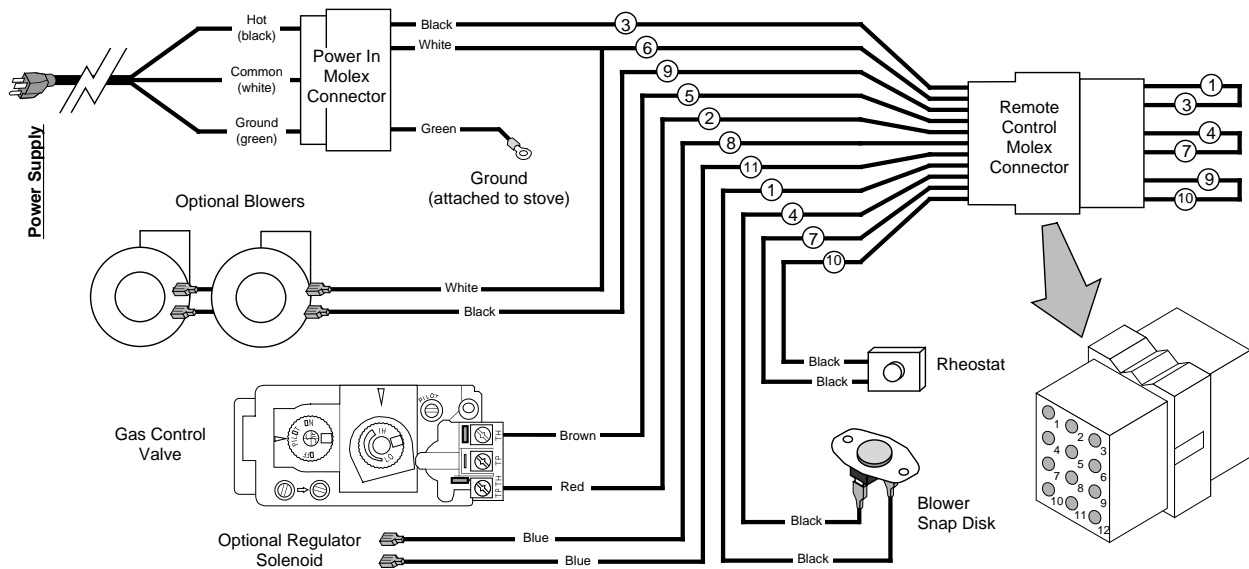

**Caution:** Label all wires prior to disconnection when servicing controls. Wiring errors can cause improper and dangerous operation.

### Replacement Parts List

**Caution:** Use only Travis Industries replacement parts. Do not use substitute materials.

**Warning:** Do not operate appliance with the glass front removed, cracked, or broken. Replacement of the glass should be done by a licensed or qualified service person.

To register your TRAVIS INDUSTRIES, INC. 7 Year Warranty, complete the enclosed Warranty card and mail it within **ten (10)** days of the appliance purchase date to: TRAVIS INDUSTRIES, INC., 4800 Harbour Pointe Blvd. SW, Mukilteo, WA 98275. TRAVIS INDUSTRIES, INC. warrants this gas appliance (appliance is defined as the equipment manufactured by Travis Industries, Inc.) to be defect-free in material and workmanship to the original purchaser from the date of purchase as follows:

Check with your dealer in advance for any costs to you when arranging a warranty call.  
Mileage or service charges are not covered by this warranty. This charge can vary from store to store.

### Years 1 & 2 - COVERAGE: PARTS & LABOR

#### Burner Assembly:

Burner, Burner Pan, Air Shutter Assembly, Main Burner

Orifice

#### Firebox Assembly:

Adjustable Air Restrictor, Pressure Relief Mechanisms, Barometric Control Mechanism (for models with Remote Heat Ducts), Glass Attachment Mechanism

#### Electrical Assembly (within heater structure):

Blower, wiring harness, snap discs, rheostat speed control

#### Gas Control Assembly

Adjustable control valve, millivolt wiring and connectors (located within the metal heater structure), thermopile, thermocouple, pilot hood, orifices, pilot gas line, piezo ignitor

#### Glass

Glass (breakage from thermal shock)

#### Ceramic Logs

Log Set, Coals, Ember Strip (Steel Fiber)

#### Gold, Nickel & Copper Plating

Face & Door (see "Conditions and Exclusions" # 9)

#### Accessories

Cast Brick, Cast Firebacks, Power Heat Ducts, Andirons

#### Convection Heat Exchanger

#### Re-Installation Allowance

In cases where heater must be removed from home for repairs, a partial cost of re-installation is covered (pre-authorization required)

#### One-Way Freight Allowance

One-way freight allowance on pre-authorized repair done at factory is covered.

**Exclusions:** Paint, Gasketing

### Years 3 THROUGH 5 - COVERAGE: PARTS & LABOR

#### Convection Heat Exchanger

#### Firebox Assembly:

Adjustable Air Restrictor, Pressure Relief Mechanisms, Barometric Control Mechanism (for models with Remote Heat Ducts), Glass Attachment Mechanism

#### One-Way Freight Allowance

One-way freight allowance on pre-authorized repair done at factory is covered.

**Exclusions:** Paint, Gasketing, Burner Assembly, Electrical Assembly, Gas Control Assembly, Glass, Ceramic Logs, Gold, Nickel & Copper Plating, Accessories, Re-Installation Allowance

### Years 6 & 7 - COVERAGE: PARTS ONLY

#### Firebox Assembly:

Adjustable Air Restrictor, Pressure Relief Mechanisms, Barometric Control Mechanism (for models with Remote Heat Ducts), Glass Attachment Mechanism

**Exclusions:** Paint, Gasketing, Burner Assembly, Electrical Assembly, Gas Control Assembly, Glass, Ceramic Logs, Gold, Nickel & Copper Plating, Accessories, Convection Heat Exchanger, Re-Installation Allowance, One-Way Freight Allowance, Labor

## CONDITIONS & EXCLUSIONS

- This new gas appliance must be installed by a qualified gas appliance technician. It must be installed, operated, and maintained at all times in accordance with the instructions in the Owner's Manual. Any alteration, willful abuse, accident, neglect, or misuse of the product shall nullify this warranty.
- This warranty is nontransferable, and is made to the ORIGINAL purchaser, provided that the purchase was made through an authorized TRAVIS dealer.
- Discoloration and some minor expansion, contraction, or movement of certain parts and resulting noise, is normal and not a defect and, therefore, not covered under warranty. The installer must ensure the appliance is burning as per the rating tag at the time of installation. Over-firing (operation above the listed BTU rate) of this appliance can cause serious damage and will nullify this warranty.
- The warranty, as outlined within this document, does not apply to the chimney components or other Non-Travis accessories used in conjunction with the installation of this product. If in doubt as to the extent of this warranty, contact your authorized TRAVIS retailer before installation.
- Travis Industries will not be responsible for inadequate performance caused by environmental conditions such as nearby trees, buildings, roof tops, wind, hills or mountains or negative pressure or other influences from mechanical systems such as furnaces, fans, clothes dryers, etc.
- This Warranty is void if:
  - The unit has been operated in atmospheres contaminated by chlorine, fluorine or other damaging chemicals.
  - The unit is subject to submersion in water or prolonged periods of dampness or condensation.
  - Any damage to the unit, combustion chamber, heat exchanger or other components due to water, or weather damage which is the result of, but not limited to, improper chimney/venting installation.
- Exclusions to this 7 Year Warranty include: injury, loss of use, damage, failure to function due to accident, negligence, misuse, improper installation, alteration or adjustment of the manufacturer's settings of components, lack of proper and regular maintenance, damage incurred while the appliance is in transit, alteration, or act of God.
- This 7 Year warranty excludes damage caused by normal wear and tear, such as paint discoloration or chipping, worn or torn gasketing, corroded or cracked logs, embers, etc. Also excluded is damage to the unit caused by abuse, improper installation, modification of the unit, drilling of the orifices, or the use of fuel other than that for which the unit is configured. Units are shipped for natural gas and must be converted to propane using the included conversion kit. Confirm fuel configuration with your installer.
- Damage to gold or nickel surfaces caused by fingerprints, scratches, melted items-, or other external sources left on the gold or nickel from the use of cleaners other than denatured alcohol is not covered in this warranty.
- TRAVIS INDUSTRIES, INC. is free of liability for any damages caused by the appliance, as well as inconvenience expenses and materials. Incidental or consequential damages are not covered by this warranty. In some states, the exclusion of incidental or consequential damage may not apply.
- This warranty does not cover any loss or damage incurred by the use or removal of any component or apparatus to or from the gas appliance without the express written permission of TRAVIS INDUSTRIES, INC. and bearing a TRAVIS INDUSTRIES, INC. label of approval.
- Any statement or representation of TRAVIS products and their performance contained in TRAVIS advertising, packaging literature, or printed material is not part of this 7 year warranty.
- This warranty is automatically voided if the appliance's serial number has been removed or altered in any way. If the appliance is used for commercial purposes, it is excluded from this warranty.
- No dealer, distributor, or similar person has the authority to represent or warrant TRAVIS products beyond the terms contained within this warranty. TRAVIS INDUSTRIES, INC. assumes no liability for such warranties or representations.
- Travis Industries will not cover the cost of the removal or re-installation of hearths, facing, mantels, venting or other components.
- If for any reason any section of this warranty is declared invalid, the balance of the warranty remains in effect and all other clauses shall remain in effect.
- THIS 7 YEAR WARRANTY IS THE ONLY WARRANTY SUPPLIED BY TRAVIS INDUSTRIES, INC., THE MANUFACTURER OF THE APPLIANCE. ALL OTHER WARRANTIES, WHETHER EXPRESS OR IMPLIED, ARE HEREBY EXPRESSLY DISCLAIMED AND PURCHASER'S RECOURSE IS EXPRESSLY LIMITED TO THE WARRANTIES SET FORTH HEREIN.

## IF WARRANTY SERVICE IS NEEDED:

- If you discover a problem that you believe is covered by this warranty, you MUST REPORT it to your TRAVIS dealer WITHIN 30 DAYS, giving them proof of purchase, the purchase date, and the model name and serial number.
- Travis Industries has the option of either repairing or replacing the defective component.
- If your dealer is unable to repair your appliance's defect, he may process a warranty claim through TRAVIS INDUSTRIES, INC., including the name of the dealership where you purchased the appliance, a copy of your receipt showing the date of the appliance's purchase, and the serial number on your appliance. At that time, you may be asked to ship your appliance, freight charges prepaid, to TRAVIS INDUSTRIES, INC. TRAVIS INDUSTRIES, INC., at its option, will repair or replace, free of charge, your TRAVIS appliance if it is found to be defective in material or workmanship within the time frame stated within this 7 year warranty. TRAVIS INDUSTRIES, INC. will return your appliance, freight charges (years 1 to 5) prepaid by TRAVIS INDUSTRIES, INC., to your regional distributor, or dealership.
- Check with your dealer in advance for any costs to you when arranging a warranty call. Mileage or service charges are not covered by this warranty. This charge can vary from store to store.

## Accessories

The accessories listed below are available at your Travis dealer. To locate a dealer, visit:

[www.travisproducts.com](http://www.travisproducts.com)

### Blower

The optional blowers help transfer heat to your home.

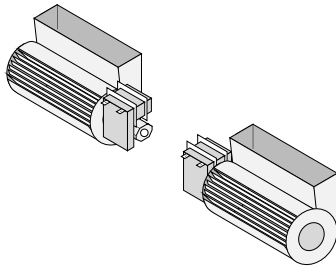

### Firebacks

There are several styles of decorative ceramic firebacks that fit inside the firebox and enhance the area behind the flames. These firebacks can also be painted in several colors available from your professional hearth dealer.

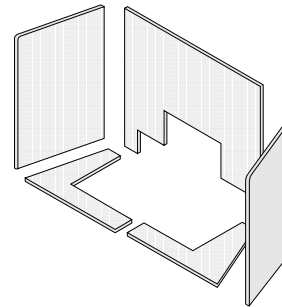

### Remote Control

This accessory allows for remote control of your fireplace.



## Index

Accessories.....	27	Normal Operating Odors.....	9
Adjusting the Flame Height.....	8	Normal Operating Sounds.....	9
Adjusting the Optional Blower Speed.....	9	Odors.....	9
Before You Begin.....	6	On/Off Operation.....	8
Blower Operation (optional).....	9	Optional Equipment List.....	27
Cleaning.....	10	Parts.....	25
Controls - Location.....	6	Pilot - Starting.....	6
Face Installation and Removal.....	12	Replacement Parts List.....	25
Features.....	3	Safety Precautions.....	4
Flame Height Adjustment.....	8	Smells.....	9
Glass Cleaning.....	22	Starting the Fireplace for the First Time.....	8
Glass Frame Removal and Installation.....	13	Starting The Pilot Flame.....	6
Grill Installation and Removal.....	11	Troubleshooting Table.....	23
Heating Specifications.....	3	Turning the Fireplace On and Off.....	8
How this Fireplace Works.....	24	Warranty.....	26
Important Information.....	2	Window Cleaning.....	22
Installation Warnings.....	2	Window Removal and Installation.....	13
Introduction.....	2	Wiring Diagram.....	25
Location of Controls.....	6	Yearly Service Procedure.....	10
Log Set Installation.....	15		
Maintaining Your Fireplace's Appearance.....	10		