



**AXM-A75**

## **Multifunction I/O Mezzanine Module**

### **USER'S MANUAL**

**ACROMAG INCORPORATED**

**30765 South Wixom Road**

**Wixom, MI 48393-2417 U.S.A.**

**Tel: (248) 624-0310**

**Fax: (248) 624-9234**

Copyright 2013, Acromag, Inc., Printed in the USA.  
Data and specifications are subject to change without notice.

**8500-927E**

1.0	GENERAL INFORMATION .....	5
	KEY FEATURES .....	5
	ENGINEERING DESIGN KIT .....	6
	BOARD CONTROL SOFTWARE .....	6
2.0	PREPARATION FOR USE .....	6
	UNPACKING AND INSPECTION .....	6
	CARD CAGE CONSIDERATIONS.....	6
	Front Panel Field I/O Connector J1 .....	8
	Analog Inputs: Noise and Grounding Considerations.....	9
	Non-Isolation Considerations .....	9
3.0	PROGRAMMING INFORMATION.....	9
	AXM-A75 Memory Map .....	9
	FLASH Data Format .....	13
	Board Status and Reset Register (Read/Write, PCIBar2 + 8000H).....	14
	Control Register - (Read/Write, PCIBar2 + 8100H) .....	15
	Status Register 0 - (Read/Write, PCIBar2 + 8104H) .....	16
	Status Register 1 - (Read/Write, PCIBar2 + 8108H) .....	16
	Digital I/O (Read/Write, PCIBar2 + 810CH).....	16
	Conversion Timer Register - (Read/Write, PCIBar2 + 8110H).....	16
	FLASH Data Register - (Read/Write, PCIBar2 + 8114H) .....	17
	Digital I/O Direction Register - (Read/Write, PCIBar2 + 8118H).....	17
	ADC Channels.....	17
	ADC Data Format .....	18
	ADC Offset Register.....	18
	ADC Gain Register .....	18
	Uncalibrated ADC Performance .....	19
	Analog Input Channel Calibration Procedure .....	19
	DAC Channels.....	20
	DAC Data Register .....	20
	DAC Coarse Gain Register .....	21
	DAC Fine Gain Register .....	21
	DAC Offset Register.....	22
	Updating DAC outputs .....	22
4.0	THEORY OF OPERATION.....	22
	Field I/O Connections.....	22

---



---

	Digital I/O .....	23
	Analog Outputs .....	24
	Analog Inputs .....	24
5.0	SERVICE AND REPAIR .....	25
	SERVICE AND REPAIR ASSISTANCE.....	25
	PRELIMINARY SERVICE PROCEDURE .....	25
	WHERE TO GET HELP .....	25
6.0	SPECIFICATIONS .....	26
	Physical .....	26
	Connectors.....	26
	Environmental.....	26
	Power Requirements .....	27
	ANALOG INPUTS.....	27
	Programmable Gain Instrumentation Amplifier.....	27
	Difference Amplifier.....	28
	Voltage Reference REF3240.....	28
	Analog to Digital Converter.....	28
	ANALOG OUTPUTS.....	29
	Digital to Analog Converter.....	29
7.0	APPENDIX.....	30
	CABLE: MODEL 5028-420 (Ultra SCSI/VHDCI male to SCSI-3 male, Round, Shielded).....	30
	TERMINATION PANEL: MODEL 5025-288 .....	31
8.0	DRAWINGS.....	32

---

---

The information contained in this manual is subject to change without notice. Acromag, Inc. makes no warranty of any kind with regard to this material, including, but not limited to, the implied warranties of merchantability and fitness for a particular purpose. Further, Acromag, Inc. assumes no responsibility for any errors that may appear in this manual and makes no commitment to update, or keep current, the information contained in this manual. No part of this manual may be copied or reproduced in any form, without the prior written consent of Acromag, Inc.

**IMPORTANT SAFETY CONSIDERATIONS**

**It is very important for the user to consider the possible adverse effects of power, wiring, component, sensor, or software failures in designing any type of control or monitoring system. This is especially important where economic property loss or human life is involved. It is important that the user employ satisfactory overall system design. It is agreed between the Buyer and Acromag, that this is the Buyer's responsibility.**

**WARNING: The AXM-A75 length dimension exceeds the "CMC I/O envelope" as shown in IEEE 1386-2001 Figure 4.1 and Figure 4.2 by 7.5mm (limited to 31mm) and is not compatible with all PMC/XMC carriers. The AXM-A75 when plugged into a compatible Acromag PMC/XMC module will work in most air-cooled Acromag non-processor carriers including the AcPC46xx, APC-PMC, APCe867x, & VPX482x models. It is not compatible with the VPX481x series or any Acromag processor board that has a PMC/XMC slot. Contact the factory with any questions.**

---

## 1.0 GENERAL INFORMATION

---

The AXM-A75 is a high speed analog input/output mezzanine board compatible with Acromag's line of re-configurable PMC and XMC FPGA modules. The AXM-A75 has 16 differential analog inputs, 8 analog outputs and 16 digital inputs/outputs.

### KEY FEATURES

**High Speed Analog Input** - sixteen independent 16-bit Analog to Digital Converter (ADC) channels provide simultaneous sampling at a maximum rate of 500 KHz. The digitized output of each ADC is simultaneously input to the Field Programmable Gate Array (FPGA) for data collection and processing.

**Programmable Input Voltage Range** - four gain selections are available that allow a bipolar input voltage range from  $\pm 1.28$  Volts to  $\pm 10.24$  Volts.

**Analog Output** – eight 16-bit Digital to Analog Converter (DAC) channels provide simultaneous update with a maximum rate of 100 KHz.

**Programmable Output Voltage Range** – three gain selections are available that allow a bipolar output voltage range from  $\pm 10$  Volts to  $\pm 10.5263$  Volts.

**Calibration Constants** – factory calibration constants used to correct gain and offset errors are stored in on-board FLASH memory. Correction constants are stored for each channel and gain selection combination. Gain and offset correction are supported for both analog input and analog output.

**General Purpose Digital Input or Output** – sixteen general purpose I/O signals are provided. The outputs are pulled high via pull-up resistors.

**Example Design** – the example VHDL design provided in the base board EDK provides the following features:

- Control of ADC sample rate and gain selection.
- Gain and offset error correction is applied in FPGA hardware for analog inputs and on-chip for analog outputs.
- Each ADC channel includes a FIFO capable of storing 2050 samples.
- All enabled ADC channels are sampled simultaneously. ADC sample rate can range from 1/34 Hz to 500 KHz.
- Control of DAC gain selection.

**Analog Input FIFO Status Interrupts** – Interrupts can be generated when an input channel's FIFO half full condition is reached or when a FIFO overflow occurs.

## ENGINEERING DESIGN KIT

Acromag does not provide an engineering design kit specifically for the AXM-A75 module. However, an example design is included in the Engineering Design Kit of the PMC/XMC base board. Refer to the PMC/XMC base board's manual for further information on the available Engineering Design Kit.

## BOARD CONTROL SOFTWARE

Acromag does not provide board control software specifically for the AXM-A75 series board. However, the AXM-A75 module can be accessed via the control software for the base PMC or XMC module. These products (sold separately) facilitate the product interface in the following operating systems: Windows™DLL, VxWorks, and Linux. Refer to the PMC/XMC base board's manual for further information.

## 2.0 PREPARATION FOR USE

### UNPACKING AND INSPECTION



Upon receipt of this product, inspect the shipping carton for evidence of mishandling during transit. If the shipping carton is badly damaged or water stained, request that the carrier's agent be present when the carton is opened. If the carrier's agent is absent when the carton is opened and the contents of the carton are damaged, keep the carton and packing material for the agent's inspection.

For repairs to a product damaged in shipment, refer to the Acromag Service Policy to obtain return instructions. It is suggested that salvageable shipping cartons and packing material be saved for future use in the event the product must be shipped.

This board is physically protected with packing material and electrically protected with an anti static bag during shipment. It is recommended that the board be visually inspected for evidence of mishandling prior to applying power.

The board utilizes static sensitive components and should only be handled at a static-safe workstation.

### CARD CAGE CONSIDERATIONS

Refer to the specifications for loading and power requirements. Be sure that the system power supplies are able to accommodate the power requirements of the carrier board, plus the installed PMC or

---

---

XMC modules, plus the AXM-A75 within the voltage tolerances specified.

**IMPORTANT: Adequate air circulation must be provided to prevent a temperature rise above the maximum operating temperature.**

The lack of air circulation within the computer chassis is a cause for some concern. Most, if not all, computer chassis do not provide a fan for cooling of add-in boards. The dense packing of the mezzanine modules to the carrier board alone results in elevated module and carrier board temperatures, and the restricted air flow within the chassis aggravates this problem. Adequate air circulation must be provided to prevent a temperature rise above the maximum operating temperature and to prolong the life of the electronics. If the installation is in an industrial environment and the board is exposed to environmental air, careful consideration should be given to air-filtering.

### Front Panel Field I/O Connector J1

The AXM-A75 front panel field I/O connector (J1) is a 68 pin VHDCI receptacle. A cable assembly and termination panel (or user defined terminations) can be quickly mated to the field I/O connector. The pin assignment for this connector is shown in Table 2-1.

**Table 2-1 J1 Pin Assignment**

Pin Description	Number	Pin Description	Number
GND	1	DIO0	35
DIO1	2	DIO2	36
DIO3	3	DIO4	37
DIO5	4	DIO6	38
DIO7	5	GND	39
DIO8	6	DIO9	40
DIO10	7	DIO11	41
DIO12	8	DIO13	42
DIO14	9	DIO15	43
GND	10	VOUT1	44
GND	11	VOUT2	45
GND	12	VOUT3	46
GND	13	VOUT4	47
GND	14	VOUT5	48
GND	15	VOUT6	49
GND	16	VOUT7	50
GND	17	VOUT8	51
GND	18	GND	52
VIN16-	19	VIN16+	53
VIN15-	20	VIN15+	54
VIN14-	21	VIN14+	55
VIN13-	22	VIN13+	56
VIN12-	23	VIN12+	57
VIN11-	24	VIN11+	58
VIN10-	25	VIN10+	59
VIN9-	26	VIN9+	60
VIN8-	27	VIN8+	61
VIN7-	28	VIN7+	62
VIN6-	29	VIN6+	63
VIN5-	30	VIN5+	64
VIN4-	31	VIN4+	65
VIN3-	32	VIN3+	66
VIN2-	33	VIN2+	67
VIN1-	34	VIN1+	68

The sixteen differential analog input channels are labeled VINx- and VINx+ where x is the channel number 1 to 16. Analog outputs are labeled VOUTx where x is the channel number 1 to 8. Digital input / output signals are labeled DIOx where x is bit 0 to 15. Signal returns are labeled GND.



### Analog Inputs: Noise and Grounding Considerations

Differential inputs require two leads (+ and -) per channel, and provide rejection of common mode voltages. This allows the desired signal to be accurately measured. However, the signal being measured cannot be floating. It must be referenced to analog common on the AXM module and be within the normal input voltage range. Shielded cable of the shortest length possible is strongly recommended.

### Non-Isolation Considerations

The board is non-isolated, since there is electrical continuity between the logic and field I/O grounds. As such, the field I/O connections are not isolated from the system. Care should be taken in designing installations without isolation to avoid noise pickup and ground loops caused by multiple ground connections.

## 3.0 PROGRAMMING INFORMATION

This Section provides the specific information necessary to program and operate the mezzanine board.

This mezzanine board is intended only for use on specific Acromag PMC/XMC FPGA modules. As such only a small portion of I/O memory space is currently reserved for operation of the mezzanine board. The remaining memory space is defined in the base board's User's Manual.

### AXM-A75 Memory Map

The AXM-A75 specific memory space address map for the board is shown in Table 3-1. Note that the base address from the base PMC/XMC module in memory space must be added to the addresses shown to properly access the board registers. Register accesses as 32, 16, and 8-bits in memory space are permitted unless otherwise indicated. A detailed description of each of the registers follows after Table 3-1.

**Table 3-1 Memory Map**

PCIBar2 + (Hex)	D31	D16	D15	D00	PCIBar2 + (Hex)
0003 ↓ 7FFF	Reserved for base PMC/XMC Module				0000 ↓ 7FFC
8003	<a href="#">Board Status Register and Software Reset</a>				8000
8007 ↓ 80FF	Reserved for base PMC/XMC Module				8004 ↓ 80FC
8103	<a href="#">Control Register</a>				8100

PCIBar2 + (Hex)	D31	D16	D15	D00	PCIBar2 + (Hex)
8107	<a href="#">Status Register 0</a>				8104
810B	<a href="#">Status Register 1</a>				8108
810F	<a href="#">Digital I/O</a>				810C
8113	<a href="#">Conversion Timer</a>				8110
8117				<a href="#">FLASH data</a>	8114
811B				<a href="#">Digital I/O Direction</a>	8118
811F ↓ 81FF	unused				811C ↓ 81FC
8203				<a href="#">ADC 1 data</a>	8200
8207	<a href="#">ADC1 gain correction</a>				8204
820B				<a href="#">ADC 1 offset</a>	8208
820F	unused				820C
8213				ADC 2 data	8210
8217	ADC 2 gain correction				8214
821B				ADC 2 offset	8218
821F	unused				821C
8223				ADC 3 data	8220
8227	ADC 3 gain correction				8224
822B				ADC 3 offset	8228
822F	unused				822C
8233				ADC 4 data	8230
8237	ADC 4 gain correction				8234
823B				ADC 4 offset	8238
823F	unused				823C
8243				ADC 5 data	8240
8247	ADC 5 gain correction				8244
824B				ADC 5 offset	8248
824F	unused				824C
8253				ADC 6 data	8250
8257	ADC 6 gain correction				8254
825B				ADC 6 offset	8258
825F	unused				825C
8263				ADC 7 data	8260
8267	ADC 7 gain correction				8264
826B				ADC 7 offset	8268
826F	unused				826C
8273				ADC 8 data	8270
8277	ADC 8 gain correction				8274
827B				ADC 8 offset	8278
827F	unused				827C
8283				ADC 9 data	8280
8287	ADC 9 gain correction				8284
828B				ADC 9 offset	8288
828F	unused				828C
8293				ADC 10 data	8290

PCIBar2 + (Hex)	D31	D16	D15	D00	PCIBar2 + (Hex)
8297	ADC 10 gain correction				8294
829B	ADC 10 offset				8298
829F	unused				829C
82A3	ADC 11 data				82A0
82A7	ADC 11 gain correction				82A4
82AB	ADC 11 offset				82A8
82AF	unused				82AC
82B3	ADC 12 data				82B0
82B7	ADC 12 gain correction				82B4
82BB	ADC 12 offset				82B8
82BF	unused				82BC
82C3	ADC 13 data				82C0
82C7	ADC 13 gain correction				82C4
82CB	ADC 13 offset				82C8
82CF	unused				82CC
82D3	ADC 14 data				82D0
82D7	ADC 14 gain correction				82D4
82DB	ADC 14 offset				82D8
82DF	unused				82DC
82E3	ADC 15 data				82E0
82E7	ADC 15 gain correction				82E4
82EB	ADC 15 offset				82E8
82EF	unused				82EC
82F3	ADC 16 data				82F0
82F7	ADC 16 gain correction				82F4
82FB	ADC 16 offset				82F8
82FF	unused				82FC
8303	<a href="#">DAC 1 data</a>				8300
8307	<a href="#">DAC 1 coarse gain</a>				8304
830B	<a href="#">DAC 1 fine gain</a>				8308
830F	<a href="#">DAC 1 offset</a>				830C
8313	DAC 2 data				8310
8317	DAC 2 coarse gain				8314
831B	DAC 2 fine gain				8318
831F	DAC 2 offset				831C
8323	DAC 3 data				8320
8327	DAC 3 coarse gain				8324

PCIBar2 + (Hex)	D31	D16	D15	D00	PCIBar2 + (Hex)
<b>832B</b>				DAC 3 fine gain	<b>8328</b>
<b>832F</b>				DAC 3 offset	<b>832C</b>
<b>8333</b>			DAC 4 data		<b>8330</b>
<b>8337</b>				DAC 4 coarse gain	<b>8334</b>
<b>833B</b>				DAC 4 fine gain	<b>8338</b>
<b>833F</b>				DAC 4 offset	<b>833C</b>
<b>8343</b>			DAC 5 data		<b>8340</b>
<b>8347</b>				DAC 5 coarse gain	<b>8344</b>
<b>834B</b>				DAC 5 fine gain	<b>8348</b>
<b>834F</b>				DAC 5 offset	<b>834C</b>
<b>8353</b>			DAC 6 data		<b>8350</b>
<b>8357</b>				DAC 6 coarse gain	<b>8354</b>
<b>835B</b>				DAC 6 fine gain	<b>8358</b>
<b>835F</b>				DAC 6 offset	<b>835C</b>
<b>8363</b>			DAC 7 data		<b>8360</b>
<b>8367</b>				DAC 7 coarse gain	<b>8364</b>
<b>836B</b>				DAC 7 fine gain	<b>8368</b>
<b>836F</b>				DAC 7 offset	<b>836C</b>
<b>8373</b>			DAC 8 data register		<b>8370</b>
<b>8377</b>				DAC 8 coarse gain	<b>8374</b>
<b>837B</b>				DAC 8 fine gain	<b>8378</b>
<b>837F</b>				DAC 8 offset	<b>837C</b>
<b>8383</b> ↓ <b>1FFFFFF</b>	Reserved for base PMC Module				<b>8380</b> ↓ <b>1FFFFC</b>

**FLASH Data Format**

Factory calibration constants are stored in FLASH memory. The FLASH memory device is a Numonyx M25P10. **Table 3-2Error! Reference source not found.** shows the memory map of the FLASH contents. All numeric constants are 32 bit values stored in little endian byte order.

**Table 3-2 FLASH Memory Map**

Addr	D31	D16	D15	D00	Addr
0007	FLASH ID = "AXM-A75" (null terminated character string)				0000
000B	10.24 Volt Range Channel 1 Offset				0008
000F	10.24 Volt Range Channel 2 Offset				000C
0013	10.24 Volt Range Channel 3 Offset				0010
	.				
0047	10.24 Volt Range Channel 16 Offset				0044
004B	10.24 Volt Range Channel 1 Gain				0048
004F	10.24 Volt Range Channel 2 Gain				004C
0053	10.24 Volt Range Channel 3 Gain				0050
	.				
0087	10.24 Volt Range Channel 16 Gain				0084
008B	5.12 Volt Range Channel 1 Offset				0088
008F	5.12 Volt Range Channel 2 Offset				008C
0093	5.12 Volt Range Channel 3 Offset				0090
	.				
00C7	5.12 Volt Range Channel 16 Offset				00C4
00CB	5.12 Volt Range Channel 1 Gain				00C8
00CF	5.12 Volt Range Channel 2 Gain				00CC
00D3	5.12 Volt Range Channel 3 Gain				00D0
	.				
0107	5.12 Volt Range Channel 16 Gain				0104
010B	2.56 Volt Range Channel 1 Offset				0108
010F	2.56 Volt Range Channel 2 Offset				010C
0113	2.56 Volt Range Channel 3 Offset				0110
	.				
0147	2.56 Volt Range Channel 16 Offset				0144
014B	2.56 Volt Range Channel 1 Gain				0148
014F	2.56 Volt Range Channel 2 Gain				014C
0153	2.56 Volt Range Channel 3 Gain				0150
	.				

Addr	D31	D16	D15	D00	Addr
<b>0187</b>	2.56 Volt Range		Channel 16 Gain		<b>0184</b>
<b>018B</b>	1.28 Volt Range		Channel 1 Offset		<b>0188</b>
<b>018F</b>	1.28 Volt Range		Channel 2 Offset		<b>018C</b>
<b>0193</b>	1.28 Volt Range		Channel 3 Offset		<b>0190</b>
<b>01C7</b>	1.28 Volt Range		Channel 16 Offset		<b>01C4</b>
<b>01CB</b>	1.28 Volt Range		Channel 1 Gain		<b>01C8</b>
<b>01CF</b>	1.28 Volt Range		Channel 2 Gain		<b>01CC</b>
<b>01D3</b>	1.28 Volt Range		Channel 3 Gain		<b>01D0</b>
<b>0207</b>	1.28 Volt Range		Channel 16 Gain		<b>0204</b>
<b>020B</b>	DAC Offset Channel 1				<b>0208</b>
<b>020F</b>	DAC Offset Channel 2				<b>020C</b>
<b>0213</b>	DAC Offset Channel 3				<b>0210</b>
<b>0227</b>	DAC Offset Channel 8				<b>0224</b>
<b>0247</b>	Unused				<b>0228</b>
<b>024B</b>	DAC Gain Channel 1				<b>0248</b>
<b>024F</b>	DAC Gain Channel 2				<b>024C</b>
<b>0253</b>	DAC Gain Channel 3				<b>0250</b>
<b>0267</b>	DAC Gain Channel 8				<b>0264</b>

**Board Status and Reset Register (Read/Write, PCIBar2 + 8000H)**

This read/write register is used to issue a software reset, view and clear pending interrupts, and to identify the attached AXM module. It may also provide other functions that are defined by the base board. Writing a "1" to bit 31 of this register will cause a software reset affecting both the PMC base board and the majority of AXM-A75 registers. Bits 15 to 13 are used for AXM identification code.

**Read** of this register reflects the interrupt pending status. Read of a "1" in bits 1 or 0 indicates that an interrupt is pending for the corresponding interrupt.

**Table 3-3 Board Status and Reset Register 8000H**

BIT	FUNCTION
<b>31</b>	Software Reset (Write Only)

BIT	FUNCTION	
<b>30- 16</b>	Reserved for base board	
<b>15 - 13</b>	AXM Identification bits (Read Only)	
	AXM-EDK	"001"
	AXM-A75	"011"
<b>12 - 2</b>	Reserved for base board	
<b>1</b>	FIFO overflow interrupt pending	
<b>0</b>	FIFO half full interrupt pending	

### Control Register - (Read/Write, PCIBar2 + 8100H)

The control register is used to enable interrupts, control amplifier gain, control the FLASH chip select signal, and start/stop the A/D converter for each channel. See Table 3-4 for a description of each of the register bits.

**Table 3-4 Control Register 8100H**

BIT	FUNCTION
<b>31</b>	FIFO overflow interrupt enable
<b>30</b>	FIFO half full interrupt enable
<b>29 – 28</b>	Amplifier Gain "00" Gain 1, full scale input range $\pm 10.24$ Volts "01" Gain 2, full scale input range $\pm 5.12$ Volts "10" Gain 4, full scale input range $\pm 2.56$ Volts "11" Gain 8, full scale input range $\pm 1.28$ Volts
<b>27</b>	FLASH Select – This bit is connected directly to the "select" input of the serial FLASH device.
<b>26</b>	LDAC – transfer DAC data from data registers to output registers, all channels (write only, read zero)
<b>25</b>	CLR – clear DAC data registers to 0x00 all channels, (write only, read zero)
<b>24 – 16</b>	unused
<b>15 – 0</b>	Convert channel [16 .. 1]– each channel can be individually controlled 0 – channel stopped 1 – enable continuous conversion

**Status Register 0 - (Read/Write, PCIBar2 + 8104H)**

Status Register 0 provides access to the FIFO overflow and half full status bits for each channel.

**Table 3-5 Status Register 0 8104H**

BIT	FUNCTION
31- 16	FIFO overflow interrupt pending / clear channel [16 .. 1] A '1' indicates that at least one A/D sample was lost due to an attempted write to a full FIFO. Write a '1' to clear the bit.
15 - 0	FIFO half full interrupt pending channel [16 .. 1] A '1' indicates that there are at least 1024 samples in the FIFO.

**Status Register 1 - (Read/Write, PCIBar2 + 8108H)**

Status Register 1 provides access to the FIFO empty status bits for each channel.

**Table 3-6 Status Register 1 8108H**

BIT	FUNCTION
31 – 16	Unused
15 – 0	FIFO empty channel [16 .. 1] A '1' indicates that the FIFO is empty.

**Digital I/O (Read/Write, PCIBar2 + 810CH)**

The Digital I/O register provides access to the 16 digital I/O lines. Digital I/O lines are pulled high via a 4.75K Ohm resistor to +5 Volts. The levels of the digital I/O lines are returned upon a read to this address. The appropriate output enable bit must be '1' in the Digital I/O Direction register to enable writing to a digital output.

**Table 3-7 Digital I/O 810CH**

BIT	FUNCTION
31 - 16	unused
15 - 0	Digital I/O signals [15 .. 0]

**Conversion Timer Register - (Read/Write, PCIBar2 + 8110H)**

This read/write register controls the sample period of all A/D converters. Sample period = count \* ADC Clock Period. Set count to zero to allow A/D converters to sample at their maximum rate of 500 KHz. For sample rates less than 500 KHz, enter a count > 2  $\mu$ S/ADC Clock Period. This register must be written using a 32 bit write command. The minimum sample period is 2  $\mu$ S. The maximum sample period is  $(2^{32} - 1) * \text{ADC Clock Period}$ . The ADC Clock Period for the various models is shown Table 3-8 (exception: XMC-SLX-150(-1M) clock period in 20 ns which results in a maximum sample rate of 420 KHz) .



**Table 3-8 ADC Clock Period**

Module	Clock Period
PMC-LXxxx	10.101 ns
PMC/XMC-SLXxxx, PMC/XMC-VxXxxx,	8 ns
XMC-SLX-150(-1M)	20 ns
XMC-7A200, XMC-7KxxxAX	10 ns

**Table 3-9 Conversion Timer 8110H**

BIT	FUNCTION
31 – 0	Sample Period = register value * ADC Clock Period

**FLASH Data Register - (Read/Write, PCIBar2 + 8114H)**

A byte write to this address triggers a write/read serial transfer to/from the serial FLASH device. A byte read from this address returns the data read from a previous write/read serial transfer.

WARNING: Factory calibration data is stored in FLASH. Writing to FLASH could result in loss of factory calibration data. See **Error! Reference source not found.**

**Table 3-10 FLASH Data Register 8114H**

BIT	FUNCTION
31 - 8	unused
7 - 0	FLASH data

**Digital I/O Direction Register - (Read/Write, PCIBar2 + 8118H)**

The Digital I/O Direction provides an output enable for each of the 16 digital I/O lines. Write a '1' to a bit to enable the output.

**Table 3-11 Digital I/O 8118CH**

BIT	FUNCTION
31 - 16	unused
15 - 0	Digital I/O Direction [15 .. 0] 0 – input 1 – output

**ADC Channels**

There are three registers associated with each of the sixteen ADC channels: data, gain correction, and offset correction. The data register is a 16-bit read only register. Reading this register will retrieve the oldest value from the FIFO associated with that channel. Each of the ADC channels will apply a gain and offset correction to each sample prior to writing the result to a FIFO. The addition and multiplication operations are done in FPGA hardware using one of the FPGA's DSP blocks for each channel. The gain and offset registers are set to one and zero respectively upon reset to pass uncorrected ADC values to the FIFOs. Typical start-up operation would include reading factory calibration constants from AXM-A75 on-board FLASH memory and writing the appropriate correction values for the currently

selected full scale range to the gain and offset registers for each channel.

### ADC Data Format

The output from the ADC is offset binary format as shown in Table 3-12. The full scale range ( $\pm 10.24$ ,  $\pm 5.12$ ,  $\pm 2.56$ ,  $\pm 1.28$ ) is controlled by the gain selection in the control register. See Table 3-4.

**Table 3-12 ADC Data Format**

DESCRIPTION	DIGITAL OUTPUT
+ Full Scale	FFFF
Midscale (zero)	8000
1 LSB Below Midscale	7FFF
- Full Scale	0000

### ADC Offset Register

The offset register contains a 16 bit two's complement value that is added to the value output from the ADC to correct offset errors. There is a separate offset register for each channel.

### ADC Gain Register

The gain register is a 17 bit fixed point positive fractional number ranging from 0 to 1.999984 weighted as shown in Table 3-13. The 17 bit fixed point number is least significant bit justified in a 32 bit register. This number is multiplied by the offset corrected ADC value

to correct for gain errors. There is a separate gain register for each channel.

**Table 3-13 Gain Register Number Format**

BIT	Binary Fixed Point
31 - 17	(unused, read as 0)
16	1
15	1/2
14	1/4
13	1/8
12	1/16
11	1/32
10	1/64
9	1/128
8	1/256
7	1/1024
6	1/2048
5	1/4096
4	1/8192
3	1/16536
2	1/32768
1	1/65536
0	1/131072

### Uncalibrated ADC Performance

The uncalibrated analog input channel performance is affected by four error sources. These are the instrumentation amplifier, difference amplifier, ADC reference and the ADC. Each of these devices can contribute to the offset and gain error of the system. These errors can be corrected by calibration.

### Analog Input Channel Calibration Procedure

Accurate calibration of the analog input channel digitized values can be accomplished by applying external precision calibration voltages.

The calibration voltages are used to find two points that determine the straight line characteristic of the analog channel.

Factory calibration constants are calculated using the following equations.

$$Gain = 1, 2, 4 \text{ or } 8$$

$$FullScaleRange = \frac{20.48}{Gain}$$

$$IdealZero = \frac{-10.24}{Gain}$$

$$IdealSlope = \frac{2^{16}}{FullScaleRange}$$

$$ActualSlope = \frac{CountCALHI - CountCALLO}{VoltsCALHI - VoltsCALLO}$$

$$ActualIntercept = CountCALHI - ActualSlope * VoltsCALHI$$

$$Offset = IdealZero * ActualSlope + ActualIntercept$$

$$CorrectionFactor = \frac{IdealSlope}{ActualSlope}$$

$$OffsetCorrection = ||Offset||$$

$$GainCorrection = ||CorrectionFactor * 2^{16}||$$

The values calculated for OffsetCorrection and GainCorrection are stored in FLASH memory for each gain selection for each ADC channel. The values are then used in the following equation to correct each input sample for offset and gain errors.

$$CorrectedData = \frac{(CountIN + OffsetCorrection) * GainCorrection}{2^{16}}$$

Note: The average of many ADC values (e.g. 2048) should be used when calculating new correction coefficients to reduce the measurement uncertainty.

## DAC Channels

There are four registers associated with each of the eight ADC channels: data, coarse gain correction, fine gain correction and offset correction. The data register is a 16-bit write/read register. Reading this register will retrieve the last value that was loaded into the DAC register for that channel. Each of the D/A channels will apply a gain and offset correction to each output word. The addition and multiplication operations are done in each DAC device. The gain and offset registers are set to one and zero respectively upon reset to pass uncorrected DAC values to the outputs. Typical start-up operation would include reading factory calibration constants from AXM-A75 on-board FLASH memory and writing the appropriate correction values for the currently selected full scale range to the coarse gain, fine gain and offset registers for each channel.

## DAC Data Register

The DAC data format is 16 bit offset binary. The ideal output from the DAC for some select output codes is shown in Table 3-14. The full scale range (FSR) is controlled by the coarse gain selection register for

each channel (See Table 3-4). The FSR choices are  $\pm 10$ ,  $\pm 10.2564$  and  $\pm 10.5263$  Volts.

**Table 3-14 DAC Data Format**

Volts	DIGITAL OUTPUT
+FSR * 32767/32768	FFFF
+FSR * 1/32767	8001
Midscale (zero)	8000
-FSR * 1/32767	7FFF
-FSR * 32767/32768	0000

**DAC Coarse Gain Register**

The coarse gain register is a two bit register that allows the selection of one of three Full Scale Ranges:  $\pm 10$ ,  $\pm 10.2564$  and  $\pm 10.5263$  Volts as shown in Table 3-15. There is a separate coarse gain register for each channel.

**Table 3-15 DAC Coarse Gain Selections**

FSR Volts	Register Value
$\pm 10$	0
$\pm 10.2564$	1
$\pm 10.5263$	2

**DAC Fine Gain Register**

The fine gain register is a six bit register that allows the user to adjust the gain of each DAC by  $-32$  LSBs to  $+31$  LSBs in 1 LSB steps, as shown in Table 3-16.

**Table 3-16 DAC Fine Gain Selections**

Gain Adjustment	FG5	FG4	FG3	FG2	FG1	FG0
+31 LSBs	0	1	1	1	1	1
+30 LSBs	0	1	1	1	1	0
No adjustment	0	0	0	0	0	0
-30 LSBs	1	0	0	0	0	1
-31 LSBs	1	0	0	0	0	0

## DAC Offset Register

The offset register is an eight bit register that allows the user to adjust the offset of each DAC by  $-16$  LSBs to  $+15.875$  LSBs in steps of one-eighth LSB, as shown in Table 3-17.

**Table 3-17 DAC Offset Correction**

Gain Adjustment	OF7	OF6	OF5	OF4	OF3	OF2	OF1	OF0
+15.875 LSBs	0	1	1	1	1	1	1	1
+15.75 LSBs	0	1	1	1	1	1	1	0
No adjustment	0	0	0	0	0	0	0	0
-15.875 LSBs	1	0	0	0	0	0	0	1
-16 LSBs	1	0	0	0	0	0	0	0

Note: the LDAC bit in the control register must be written to trigger a transfer from the DAC data registers to the DAC offset register.

## Updating DAC outputs

The values written to the DAC data registers are not immediately applied to the DAC outputs. The LDAC bit in the control register must be written to trigger a transfer from the DAC data registers to the DAC outputs (see Table 3-4). The transfer from the data register to DAC outputs occurs simultaneously for all DAC channels.

## 4.0 THEORY OF OPERATION

### Field I/O Connections

The field I/O interface to the AXM-A75 is provided through connector P1 (refer to Table 2-1). **Field I/O signals are NON-ISOLATED.** This means that the field return and logic common have a direct electrical connection to each other. As such, care must be taken to avoid ground loops (see Section 2.0 for

connection recommendations). Ignoring this effect may cause operation errors, and with extreme abuse, possible circuit damage.

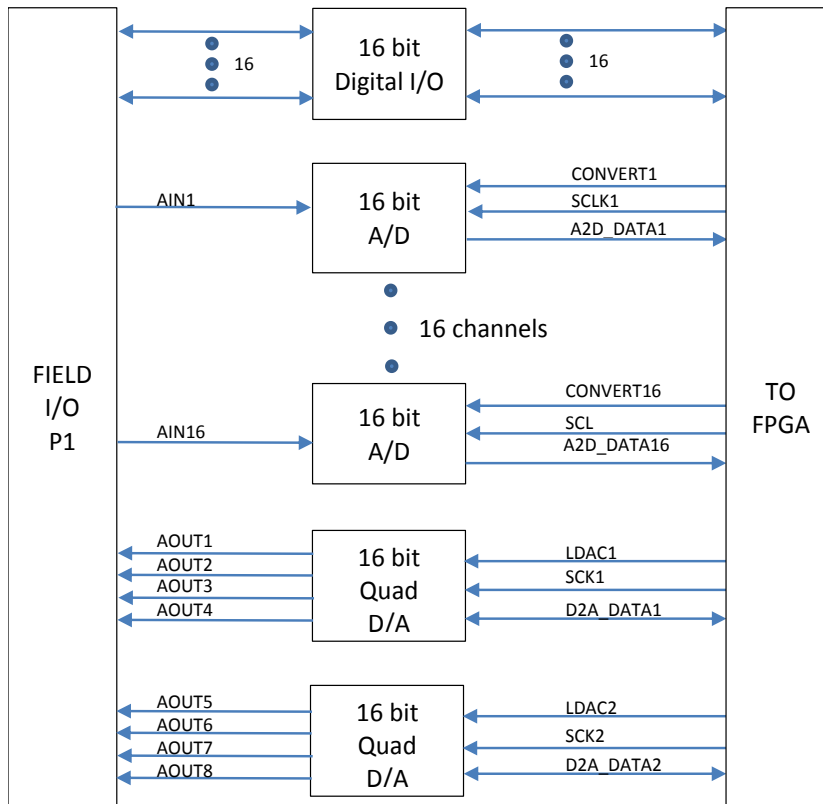
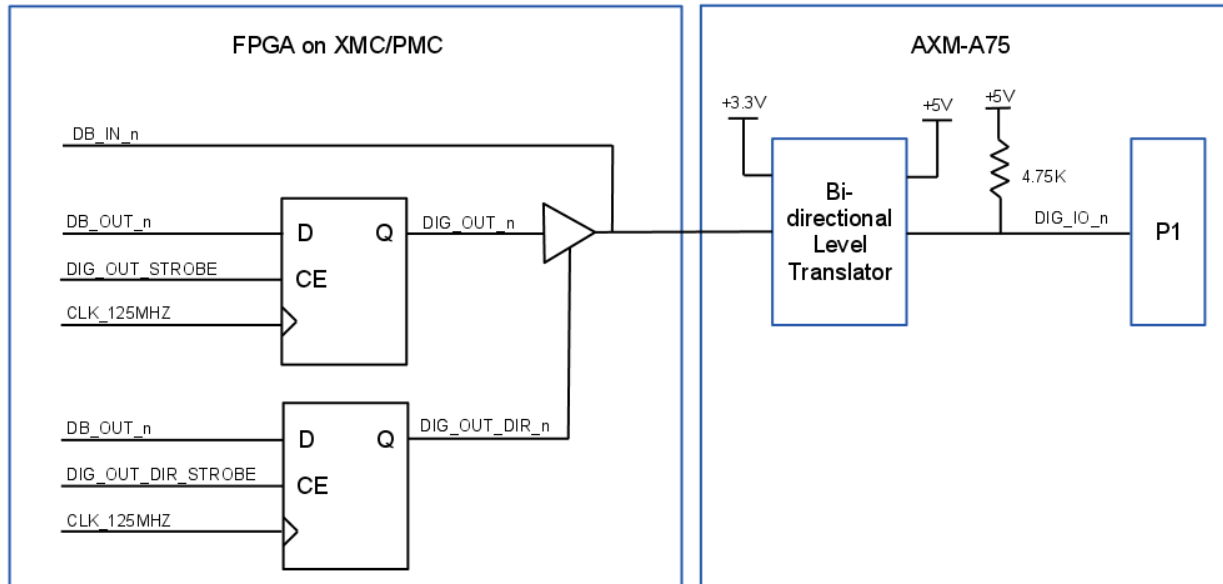

Figure 1 AXM-A75 Block Diagram

### Digital I/O

A block diagram of a single digital I/O channel is shown in Figure 2 Digital I/O. This structure is replicated 16 times on the AXM-A75. The signal DIG\_OUT\_STROBE is activated upon a write to the Digital I/O register. The level of DIG\_IO\_n is returned upon a read of the Digital I/O register. The signal DIG\_OUT\_DIR\_STROBE is activated upon a write to the Digital I/O Direction Register. When the DIG\_OUT\_DIR\_n signal is logic high the contents of the DIG\_OUT\_n flip-flop will be

driven onto the DIG\_IO\_n signal. The level translator is a NXP GTL2010.



**Figure 2 Digital I/O**

## Analog Outputs

Two Analog Devices AD5764R quad bipolar voltage output DACs are used to provide the eight analog output channels. Each DAC uses its own on-chip reference as its reference source. Although each DAC has separate clock, sync, load and serial I/O signals connected to the FPGA, the firmware as delivered with the EDK provides access to only a single quad DAC at a time. The CLR, BIN2SCOMP and RESET signals are common to both DACs.

## Analog Inputs

Each of the analog input channels consists of a differential low pass filter followed by an instrumentation amplifier, a difference amplifier and an ADC.

The differential low pass RC filter is intended to reduce RF interference. The 3db cutoff frequency of the filter is 421 kHz differential, 8.84 MHz common mode.

An Analog Devices AD8251 Programmable Gain (Instrumentation) Amplifier (PGA) takes as input the channel's + and - inputs and outputs a single ended voltage proportional to it. The gain can be 1, 2, 4, or 8 and is selected through the gain selection bits in the control register. The gain selection affects all channels.



---

---

The output from the PGA is input to a Texas Instruments INA159 level translation difference amplifier that divides its input voltage by 5 and level shifts the output by one half of the 4.096 reference voltage. The output from the difference amplifier drives an Analog Devices AD7686 16 bit, 500 kSPS ADC. Each of the ADCs has separate clock, convert and serial data connections to the FPGA allowing synchronous acquisition and simultaneous data transfer.

## 5.0 SERVICE AND REPAIR

---

### SERVICE AND REPAIR ASSISTANCE

Surface-Mounted Technology (SMT) boards are generally difficult to repair. It is highly recommended that a non-functioning board be returned to Acromag for repair. The board can be damaged unless special SMT repair and service tools are used. Further, Acromag has automated test equipment that thoroughly checks the performance of each board.

Please refer to Acromag's Service Policy Bulletin or contact Acromag for complete details on how to obtain parts and repair.

### PRELIMINARY SERVICE PROCEDURE

Before beginning repair, be sure that all of the procedures in section 2.0 PREPARATION FOR USE have been followed. Replacement of a suspected faulty unit with one that is known to work correctly is a good technique to isolate a faulty board.

**CAUTION: POWER MUST BE TURNED OFF BEFORE REMOVING OR INSERTING BOARDS**

### WHERE TO GET HELP

If you continue to have problems, your next step should be to visit the Acromag worldwide web site at <http://www.acromag.com>. Our web site contains the most up-to-date product and software information.

Go to the "Support" tab to access:

- Application Notes
- Frequently Asked Questions (FAQ's)
- Product Knowledge Base
- Tutorials
- Software Updates/Drivers

An email question can also be submitted from within the Knowledge Base or directly from the "Contact Us" tab.

Acromag's application engineers can also be contacted directly for technical assistance via telephone or FAX through the numbers listed below. When needed, complete repair services are also available.

Phone: 248-295-0310

Fax: 248-624-9234

Email: [solutions@acromag.com](mailto:solutions@acromag.com)

## 6.0 SPECIFICATIONS

### Physical

Physical Configuration .....	Single AXM Module
Stacking Height .....	5 mm
Length .....	38.5 mm (1.516 inches) See warning below.
Width .....	73.75 mm (2.904 inches)
Board Thickness .....	1.59 mm (0.062 inches)

**WARNING: The AXM-A75 length dimension exceeds the "CMC I/O envelope" as shown in IEEE 1386-2001 Figure 4.1 and Figure 4.2 by 7.5mm (limited to 31mm) and is not compatible with all PMC/XMC carriers. The AXM-A75 when plugged into a compatible Acromag PMC/XMC module will work in most Acromag air-cooled non-processor carriers including the AcPC46xx, APC-PMC, APCe867x, & VPX482x models. It is not compatible with the VPX481x series or any Acromag processor board that has a PMC/XMC slot. Contact the factory with any questions.**

### Connectors

P1 (FPGA Interface).....	162-pin receptacle, 5 mm stack height, high speed terminal strip (Samtec QTS-075-01-L-D-A-K)
J1 (Field I/O).....	68-pin VHDCI receptacle (Amphenol HE11-RDA-101-3-C)

### Environmental

Operating Temperature .....	0 to +70°C
Relative Humidity.....	5-95% non-condensing
Storage Temperature.....	-55°C to +150°C
Non-Isolated.....	Logic and field commons have a direct electrical connection
Radiated Field Immunity.....	Designed to comply with IEC61000-4-3 class A
Surge Immunity.....	Not required for signal I/O per European Norm EN61000-6-1
Electric Fast Transient Immunity	
	Designed to comply with IEC61000-4-4 class A
Radiated Emissions .....	Designed to comply with CISPR 16-2-3 class A
Electrostatic Discharge .....	Designed to comply with IEC6100-4-2 Level 2
Conducted Radio Frequency Interference	
	Designed to comply with IEC6100-4-6 class A

**Power Requirements**

+3.3 Volts (±5%) .....	39 mA typical 50 mA maximum
+5 Volts (±5%) .....	54 mA typical 65 mA maximum
+12V (±5%) .....	103 mA typical 115 mA maximum
-12V (±5%) .....	92 mA typical 115 mA maximum

**ANALOG INPUTS**

Device .....	ADI AD7686		
Input Channels .....	16 differential		
Input Signal Type .....	Voltage (Non-isolated)		
Input Ranges: .....	±10.24, ±5.12, ±2.56 and ±1.28 V		
Input Overvoltage Protection .....	±31 V with power on ±19 V with power off		
Input Resistance .....	5.300 GΩ, typical differential		
Input Bias Current .....	5 nA typical 40 nA maximum		
Common Mode Rejection Ratio ...	98 dB typical (60 Hz)		
Input Channel to Input Channel Rejection Ratio <sup>1</sup>	41 dB typical (100 kHz)		
Output Channel to Input Channel Rejection Ratio <sup>2</sup>	85 dB typical (1 kHz)		
Accuracy .....	Gain	% Full Scale @ 25°C	% Full Scale 0 – 70°C
	1	0.011	0.026
	2	0.013	0.029
	4	0.015	0.033
	8	0.018	0.040

**Programmable Gain Instrumentation Amplifier**

Device .....	ADI AD8251
PGA Linearity Error .....	±0.005% maximum (3.27 LSB)
Offset Error RTI <sup>3</sup> .....	±1.0 mV typical, ±2.5 mV maximum
Offset vs. Temperature .....	±(0.6 + 1.5/G) μV/°C typical (G=1,2,4,8) ±(1.2 + 5/G) μV/°C maximum

<sup>1</sup> Input channel to input channel rejection ratio was measured with a 100 KHz 1V pk-pk sine wave input on an adjacent channel.

<sup>2</sup> The output channel to input channel rejection ratio was measured with all output channels driving a 10k ohm load outputting a 1 kHz 20 V pk-pk sine wave. Load resistors were located on a termination panel connected to a 2 meter cable.

---



---

Gain Error (all gains) <sup>3</sup> .....	0.01% typical, 0.1% maximum
Gain vs. Temperature.....	3 ppm/°C typical 10 ppm/°C maximum

### Difference Amplifier

Device.....	TI INA159
Gain Error.....	±0.005% typical ±0.024% maximum
Gain Error vs. Temperature .....	±1 ppm/°C typical
Offset Error .....	±100 µV typical ±500 µV maximum
Offset Voltage vs. Temperature....	±1.5 µV/°C typical
Reference Divider Accuracy .....	±0.002% typical ±0.024% maximum

### Voltage Reference REF3240

Device.....	TI REF3240
Accuracy.....	0.01% typical ±0.2% maximum
Output Voltage Temperature Drift	4 ppm/°C typical 7 ppm/°C maximum
Thermal Hysteresis <sup>4</sup> .....	100 ppm first cycle 25 ppm additional cycles
Noise .....	78 µV RMS typical

### Analog to Digital Converter

ADC.....	ADI AD7686
A/D Resolution .....	16-bits
Data Format .....	straight binary
No Missing Codes.....	no missing codes 15-bits
A/D Integral Linearity Error.....	±0.6 LSB typical ±2 LSB maximum
Offset Error .....	±0.1 mV typical ±10 V range ±1.6 mV maximum
Gain Error Temperature Drift .....	±0.3 ppm/°C typical
Offset Temperature Drift .....	±0.3 ppm/°C typical
Full Scale Error .....	±0.5% maximum
A/D Conversion Time .....	2 µS maximum
Conversion Rate .....	500 kHz maximum
Input Noise.....	2 LSB rms typical

---

<sup>3</sup> Software calibration eliminates these error components

<sup>4</sup> Acromag does not temperature cycle this product before shipping to customers. If the product is operated at the extremes of its temperature range, the voltage reference could drift by the amount specified for first cycle.

---



---

## ANALOG OUTPUTS

### Digital to Analog Converter

Device.....	ADI AD5764RB
Resolution .....	16 bits
Output Ranges .....	$\pm 10$ , $\pm 10.2564$ , and $\pm 10.5263$ V
Settling Time .....	8 $\mu$ S typical full-scale step to $\pm 1$ LSB 10 $\mu$ S maximum
Slew Rate.....	5 V/ $\mu$ S typical
Integral Nonlinearity .....	$\pm 2$ LSB maximum
Differential Nonlinearity .....	$\pm 1$ LSB maximum
Bipolar Zero Error.....	$\pm 2$ mV maximum
Internal Reference .....	4.995 V minimum 5.005 V maximum
Short Circuit Current .....	10 mA typical
Load Current .....	$\pm 1$ mA maximum for specified performance
Capacitive Load Stability .....	200 pF maximum with $R_{LOAD}=\infty$ 1000 pF maximum with $R_{LOAD}=10K \Omega$
DC Output Impedance .....	0.3 $\Omega$ maximum
Gain Drift.....	$\pm 2$ ppm full scale range/ $^{\circ}$ C
Bipolar Zero Drift .....	$\pm 2$ ppm full scale range/ $^{\circ}$ C
Accuracy .....	0.015 % full scale @ 25 $^{\circ}$ C 0.029 % full scale @ 0 – 70 $^{\circ}$ C

---

## 7.0 APPENDIX

---

### **CABLE: MODEL 5028-420 (Ultra SCSI/VHDCI male to SCSI-3 male, Round, Shielded)**

**Type:** Round shielded cable, 34-wire pairs (Ultra SCSI/VHDCI male and SCSI-3 male connectors). The cable length is 2 meters (6.56 feet). This shielded cable is recommended for all I/O applications (both digital I/O and precision analog I/O).

**Application:** Used to connect Model 5025-288 termination panel to the board.

**Length:** 2 meters (6.56 feet)

**Cable:** 34 wire pairs, 28 AWG, foil/braided shield inside a PVC jacket.

**Connectors:** Ultra SCSI/VHDCI and SCSI-3, 68-pin male connectors with backshell. Keying: The connectors have a "D Shell".

**Schematic and Physical Attributes:** See Drawing 4502-153.

**Electrical Specifications:** 30 VAC per UL and CSA (SCSI-3 connector spec.'s). 1 Amp maximum at 50% energized (SCSI-3 connector spec.'s).

**Operating Temperature:** -30°C to +80°C.

**Storage Temperature:** -40°C to +85°C.

**Shipping Weight:** 1.0 pound (0.5Kg), packed.

---

---

**TERMINATION PANEL: MODEL 5025-288**

**Type:** Termination Panel for 68 Pin SCSI-3 Cable Connection

**Application:** To connect field I/O signals to the board.

**Termination Panel:** Acromag Part 4001-066. The 5025-288 termination panel facilitates the connection of up to 68 field I/O signals and connects to the board (connectors only) via a round shielded cable (Model 5028-432). Field signals are accessed via screw terminal strips. The terminal strip markings on the termination panel (1-68) correspond to field I/O (pins 1-68) on the board. Each board has its own unique pin assignments. Refer to the board manual for correct wiring connections to the termination panel.

**Schematic and Physical Attributes:** See Drawing 4501-920.

**Field Wiring:** 68-position terminal blocks with screw clamps. Wire range 12 to 26 AWG.

**Mounting:** Termination panel is snapped on the DIN mounting rail.

**Printed Circuit Board:** Military grade FR-4 epoxy glass circuit board, 0.063 inches thick.

**Operating Temperature:** -40°C to +100°C

**Storage Temperature:** -40°C to +100°C.

**Shipping Weight:** 1.0 pounds (0.5kg) packaged.

**DRAWINGS**

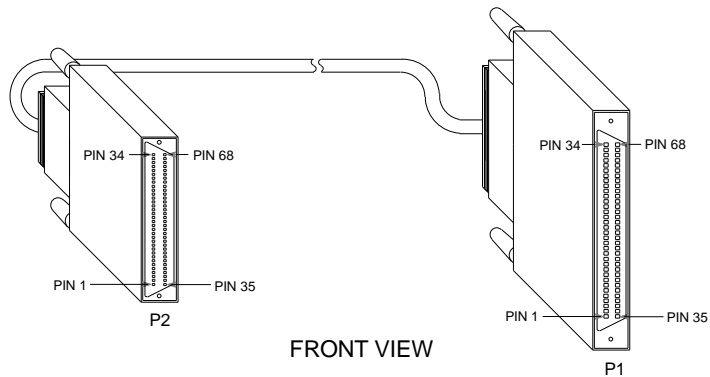
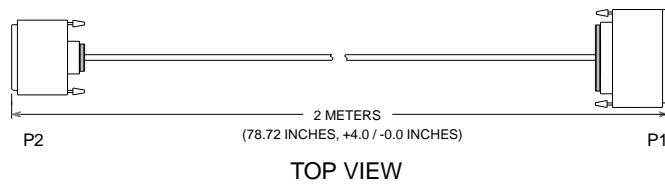
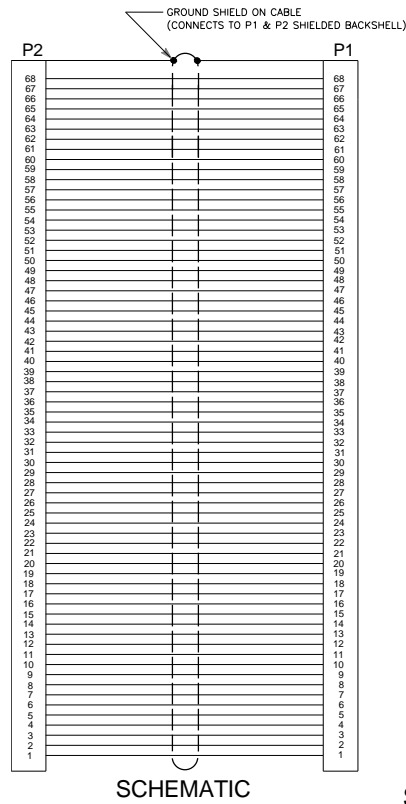

MODEL 5028-420 ULTRA SCSI/VHDCI TO SCSI-3 68 PIN CABLE ASSEMBLY, SHIELDED 4502-153A

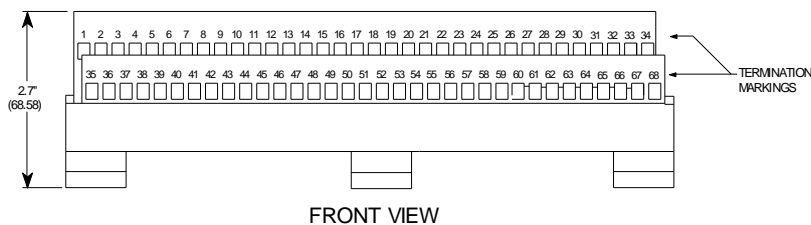
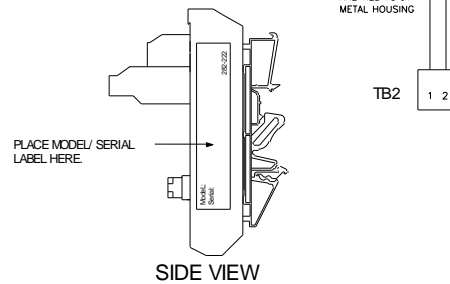
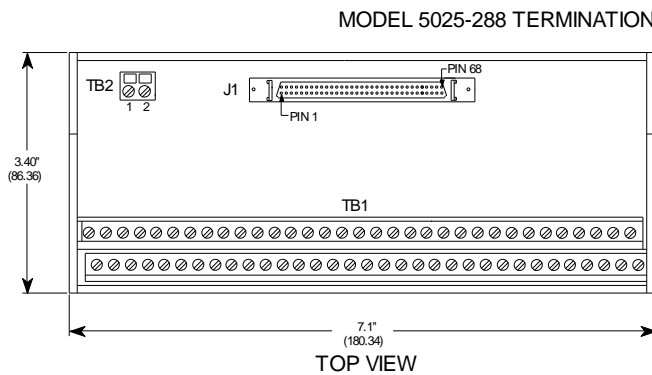
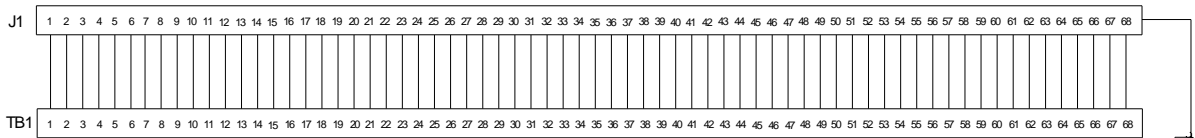

NOTE: DIMENSIONS ARE IN INCHES. (MILLIMETERS)

4501-920



**Certificate of Volatility**

Certificate of Volatility				
Acromag Model AXM-A75		Manufacturer: Acromag, Inc. 30765 Wixom Rd Wixom, MI 48393		
Volatile Memory				
Does this product contain Volatile memory (i.e. Memory of whose contents are lost when power is removed) <input type="checkbox"/> Yes <input checked="" type="checkbox"/> No				
Non-Volatile Memory				
Does this product contain Non-Volatile memory (i.e. Memory of whose contents is retained when power is removed) <input checked="" type="checkbox"/> Yes <input type="checkbox"/> No				
Type(EEPROM, Flash, etc.) Flash	Size: 1M bits	User Modifiable <input checked="" type="checkbox"/> Yes <input type="checkbox"/> No	Function: Storage of calibration constants for A/D and D/A converters	Process to Sanitize: Clear Flash memory by erasing all sectors of the Flash  Note: (calibration constants can be restored by repeating calibration procedure)
Acromag Representative				
Name: Russ Nieves	Title: Dir. of Sales and Marketing	Email: rnieves@acromag.com	Office Phone: 248-295-0838	Office Fax: 248-624-9234

**Revision History**

Release Date	Version	EGR/DOC	Description of Revision
19-FEB-13	A	JCL	Initial Acromag release.
29-JUL-14	B	JCL	Added Certificate of Volatility and exception note to conversion timer section.
8-JAN-15	C	JCL	Added support for XMC-7KxxxAX modules.
29-MAY-15	D	JCL	Added support for XMC-7A200.
04-JUNE-15	E	CAB	Added note about IEEE-1386 non-compliance on page 4 and 26. Update Acromag Representative in Certificate of Volatility.