

TOSHIBA

FILE NO. A00-9619

SERVICE MANUAL

AIR-CONDITIONER

SPLIT WALL TYPE

RAS-10SKH-E/RAS-10SAH-E

RAS-10SKHX/RAS-10SAHX

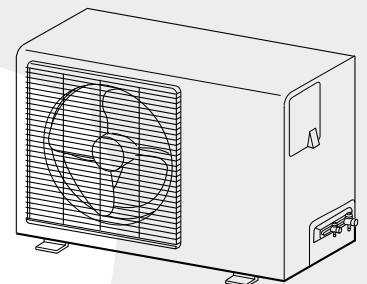
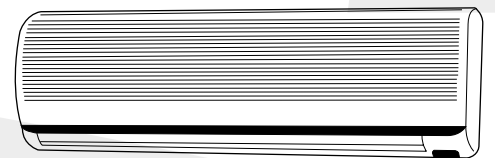

CONTENTS

1. SPECIFICATIONS	4
2. CONSTRUCTION VIEWS	6
2-1. Indoor Unit	6
2-2. Outdoor Unit	7
3. WIRING DIAGRAM	8
4. SPECIFICATIONS OF ELECTRICAL PARTS	9
4-1. Indoor Unit	9
4-2. Outdoor Unit	9
5. REFRIGERANT CYCLE DIAGRAM	10
6. MICRO-COMPUTER BLOCK DIAGRAM	11
7. OPERATION DESCRIPTIONS.....	12
7-1. FAN ONLY Operation	12
7-2. COOL Operation	12
7-2-1. Louver Control	13
7-3. DRY Operation	13
7-4. HEAT Operation	14
7-4-1. Louver Control	14
7-4-2. Cool Airflow Control	14
7-5. AUTO Operation	15
7-5-1. Temporary Auto	15
7-6. ECONO. Mode	16
7-6-1. Cooling	16
7-6-2. Heating	16
7-7. Current Limit Control	16
7-8. High-Temperature Limit Control (Heating Operation).....	17
7-9. Low-Temperature Limit Control (Cooling Operation)	17
7-10. Cool Airflow Prevention Control (Heating Operation)	17
7-11. Defrost Operation	18
7-11-1. Condition to Start the Defrost Operation	18
7-11-2. Defrost Operation Time Control	18
7-11-3. Ending Condition at Defrost Operation	18
7-12. Auto Restart Function	19
7-12-1. How to Set the Auto Restart	19
7-12-2. How to Cancel the Auto Restart	20
7-12-3. In Case of Power Failure during the Timer Operation	20
8. INSTALLATION PROCEDURE	21
8-1. Safety Cautions	21
8-2. Installation Diagram of Indoor and Outdoor Units	23
8-3. Installation	24
8-3-1. Optional Parts	24
8-3-2. Kit Parts	25

8-4. Indoor Unit	26
8-4-1. Cutting a Hole and Mounting Installation Plate	26
8-4-2. Electrical Work	27
8-4-3. Wiring Connection	28
8-4-4. Piping and Drain Hose Installation	30
8-4-5. Indoor Unit Installation	31
8-4-6. Drainage	31
8-5. Outdoor Unit	32
8-5-1. Refrigerant Piping Connection	33
8-5-2. Vacuum Pumping	33
8-5-3. Wiring Connection	34
8-6. Others	35
8-6-1. Gas Leak Test	35
8-6-2. Test Operation	35
8-6-3. Auto Restart Setting	35
9. TROUBLESHOOTING CHART	36
9-1. What to be Prechecked First	36
9-1-1. Power Supply Voltage	36
9-1-2. Incorrect Cable Connection between Indoor and Outdoor Units	36
9-1-3. Misleading but Good Operations	37
9-2. Primary Judgement of Trouble Sources	38
9-2-1. Role of Indoor Unit Controller	38
9-2-2. Display of Abnormalities and Judgement of the Abnormal Spots	38
9-3. Troubleshooting Flowcharts	42
9-3-1. Power can not be Turned on	42
9-3-2. Power can not be Turned on after Replacing Indoor PC Board	43
9-3-3. Outdoor Unit does not Operate	43
9-3-4. Only Compressor does not Operate	44
9-3-5. Only Outdoor Fan does not Operate	45
9-3-6. Only 4-Way Valve does not Operate	46
9-3-7. Only the Indoor Fan does not Operate	47
9-4. How to Check the Remote Control (Including the Indoor PC Board)	48
9-4-1. How to Check the PC Board	49
9-4-2. PC Board Layout	51
9-4-3. How to Reduce the Operation Time of the Anti-Restart Timer	52
10. PART REPLACEMENT	53
10-1. Indoor Unit	53
10-2. Microcomputer	55
10-3. Outdoor Unit	56
11. CAUTIONS ON REPLACEMENT OF PC BOARD ASSEMBLY	57
12. EXPLODED VIEWS AND PARTS LIST	58
12-1. Indoor Unit (1)	58
Indoor Unit (2)	59
Indoor Unit (3)	60
12-2. Outdoor Unit	61

1. SPECIFICATIONS

Item		Model	RAS-10SKH-E/10SAH-E, RAS-10SKHX/10SAHX					
			COOLING			HEATING		
Capacity		*1 kW	220V	230V	240V	220V	230V	240V
			2.65	2.68	2.70	3.00	3.05	3.10
Power source	Phase		Single					
	V		220/230/240					
	Hz		50					
Power consumption	kW		0.98/0.99/1.02			0.89/0.90/0.91		
Power factor	%		95/92/90			95/92/88		
Running current	A		220V	230V	240V	220V	230V	240V
	Indoor/Outdoor		0.11/4.58	0.11/4.57	0.11/4.61	0.11/4.17	0.11/4.16	0.11/4.22
Starting current	A		19					
Moisture removal	lit/h		1.2					
Noise	Indoor (H/M/L)		41/36/31					
	Outdoor (220/230/240V)		47/48/49					
Refrigerant	Name of refrigerant		R-22					
	Rated volume		0.74					
Refrigerant control			Capillary tube					
Interconnection pipe	Gas side size		9.52					
	Connection type		Flare connection					
	Liquid side size		6.35					
	Connection type		Flare connection					
	Maximum length (of one way)		10					
	Maximum height difference		5					
		Indoor unit	↑ ↓					
		Outdoor unit						
Condensate drain pipe	Outer diameter		16					
INDOOR UNIT			RAS-10SKH-E/RAS-10SKHX					
Dimensions	Height		265					
	Width		790					
	Depth		174					
Net weight	kg		8					
Evaporator type			Finned tube					
Indoor fan type			Cross flow fan					
Air volume	High fan		600					
	Medium fan		500					
	Low fan		400					
Fan motor output	W		19					
Air filter			Polypropylene net filter (Washable)					
OUTDOOR UNIT			RAS-10SAH-E/RAS-10SAHX					
Dimensions	Height		530					
	Width		770					
	Depth		200					
Net weight	kg		31					
Condenser type			Finned tube					
Outdoor fan type			Propeller					
Airflow volume	m ³ /h		1600					
Fan motor output	W		18					
Compressor	Model		PH120T1-4C					
	Output		750					
Safety device			Fuse, Overload relay					
Auto louver			Yes					
Usable outdoor temperature range	°C		21 ~ 43			- 5 ~ 21		

Specifications are subject to change without notice.

Note : *1

- Capacity is based on the following temperature conditions.

Temperature		Condition	JIS C9612-1994	
			Cooling	Heating
Indoor unit inlet air temperature	(DB)	27°C	20°C	
	(WB)	19°C	12°C	
Outdoor unit inlet air temperature	(DB)	35°C	7°C	
	(WB)	24°C	6°C	

Notes : *2 CHARGELESS

- No additional refrigerant required.
- This air conditioner accepts a connection piping length of up to 10m and a head of up to 5m.
- There is no need to add the refrigerant as long as the total length of the connection piping is up to 10m.

4. SPECIFICATIONS OF ELECTRICAL PARTS

4-1. Indoor Unit

RAS-10SKH-E

RAS-10SKHX

No.	Parts name	Type	Specifications
1	Fan motor (for indoor)	ICF-35-19-3 or TICF-35-19-3	Output (Rated) 19W, 2pole, 1phase, 220/230/240V, 50Hz
2	Thermo sensor (TA-sensor)	(microprocessor)	10k Ω at 25°C
3	DC-DC transformer (T01)	SWT-34	DC390V, Secondary DC35V, 12V, 7V
4	Microcomputer	TMP87CK40F	
5	Power relay (RY01), Common relay (RY02)	D11U	Coil : DC12V 75mA, Rated AC250V 20A
6	Heat exchanger sensor (TC-sensor)	(microprocessor)	10k Ω at 25°C
7	Line filter (L01)	RF-103YOR6	10mH, AC 0.6A
8	Diode (DB01)	RBV-406	4A, 600V
9	Capacitor (C02)	CEAUF2W101M20	100 μ F, 450V
10	Fuse (F01)	MT3	T3.15A, 250V
11	Relay (for outdoor fan motor, solenoid coil) (RY03, RY04)	AJQ1341	Coil DC12V, 33mA, Rated 1A 250V AC
12	Power supply IC (IC01)	MA2830-FJ	4A, 600V
13	Varistor (R21, 109)	15G561K	560V
14	Resistor (R01)	ERF-5TK5R6	5.6 Ω , 5W
15	Current trans (T02)	CT422920S-01	

4-2. Outdoor Unit

RAS-10SAH-E

RAS-10SAHX

No.	Parts name	Type	Specifications
1	Compressor	PH120T1-4C	Output (Rated) 750W, 2pole, 1phase, 220/230/240V, 50Hz
			Winding resistance (Ω) (at 20°C)
2	Fan motor (for outdoor)	UE6-21SJ5P	Output (Rated) 18W, 6pole, 1phase, 220/230/240V, 50Hz
			Winding resistance (Ω) (at 20°C)
3	Running capacitor (for fan motor)	SK-50CMP	500V AC, 1.5 μ F
4	Running capacitor (for compressor)	SK-40CMP25U1	400V AC, 25 μ F
5	Solenoid coil (for 4-way valve)	LB60012	AC : 200/240V
6	Overload relay	J-MRA99269-9200	U/T 6.8A (90°C), OPEN 135 \pm 5°C, CLOSE 69 \pm 11°C

5. REFRIGERANT CYCLE DIAGRAM

RAS-10SKH-E / RAS-10SAH-E

RAS-10SKHX / RAS-10SAHX

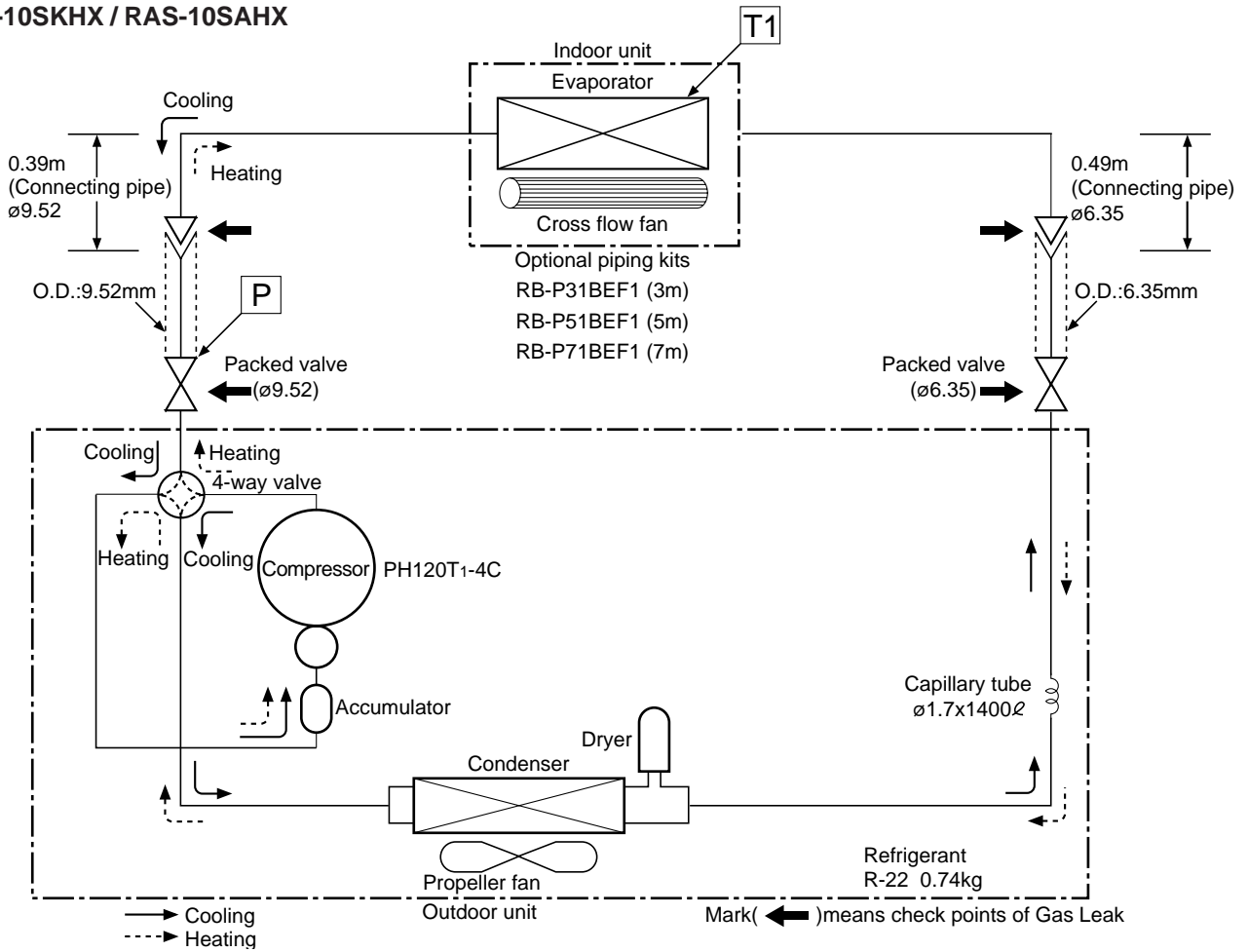

Fig. 5-1

Table 5-1

50Hz		Standard pressure P (kg/cm ² G) 10SKH-E 10SKHX	Surface temp. of heat exchanger interchanging pipe T1 (°C)		Fan speed (indoor)	Ambient temp. conditions DB/WB (°C)	
			10SKH-E 10SKHX			Indoor	Outdoor
Heating	Standard	15.0	40.0		High	20/-	7/6
	High temperature*1	19 ~ 23	52.0 ~ 59.0		Low	27/-	21/15
	Low temperature	12.5	35.0		High	20/-	-10/-10
Cooling	Standard	6.0	12.0		High	27/19	35/24
	High temperature	6.5	15.0		High	32/23	43/26
	Low temperature	4.0	2.0		Low	21/15	21/15

Note :

- Measure the heat exchanger temperature at the center of U-bend. (By means of TC sensor.)

- *1 • During heating overload, the high temperature limit control operation is included.

6. MICRO-COMPUTER BLOCK DIAGRAM

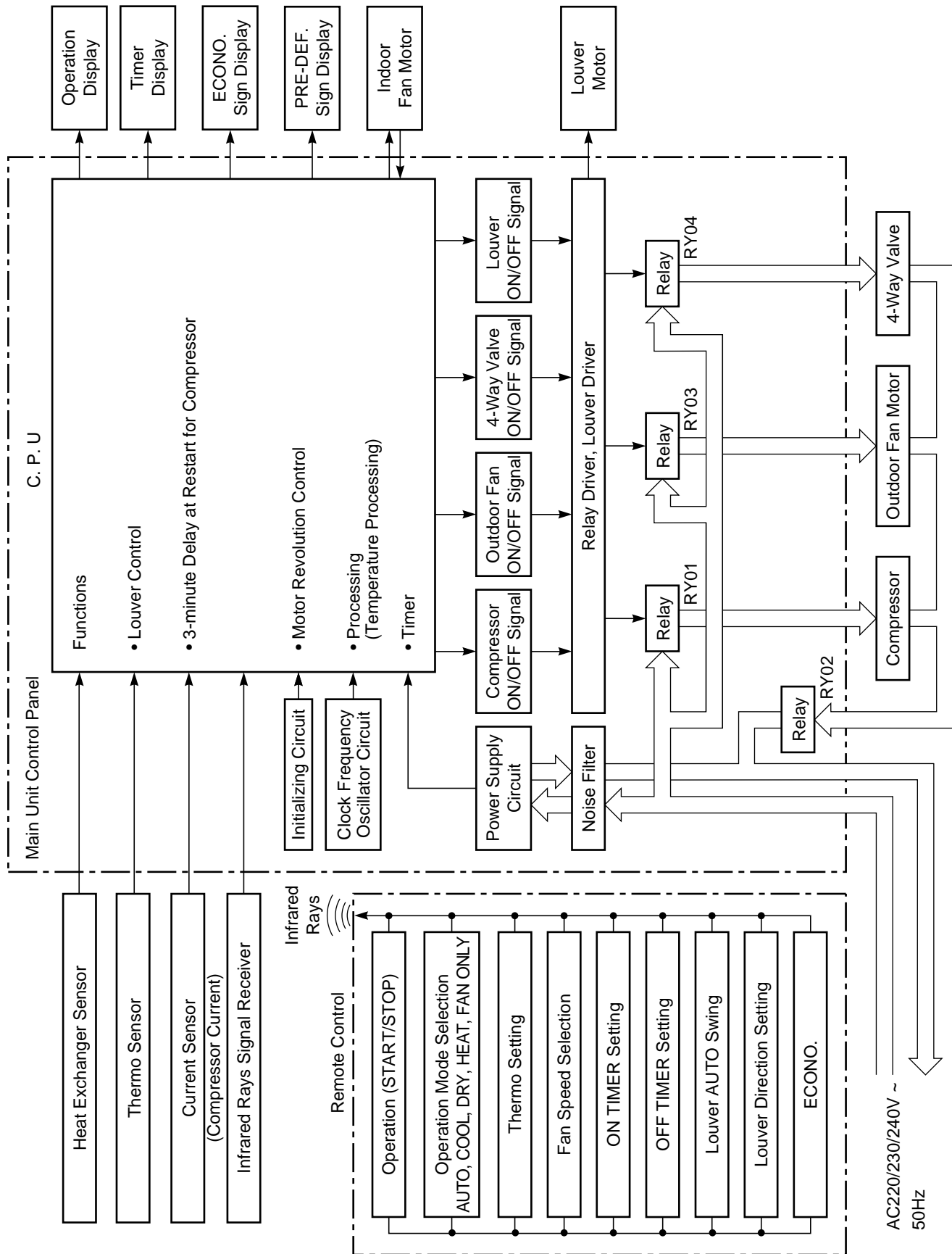

7. OPERATION DESCRIPTIONS

7-1. FAN ONLY Operation

(MODE of the remote control : FAN ONLY)

- (1) During this mode, the relay RY01 is always turned off so that only the indoor fan is operated. RY02 is always turned on.
- 1) When the FAN is set to AUTO, the indoor fan motor operates as shown in Fig 7-1-1.
- 2) When the FAN is set to LOW, MED, or HIGH, the indoor fan motor operates with a constant in volume as listed in Table 7-1-1.

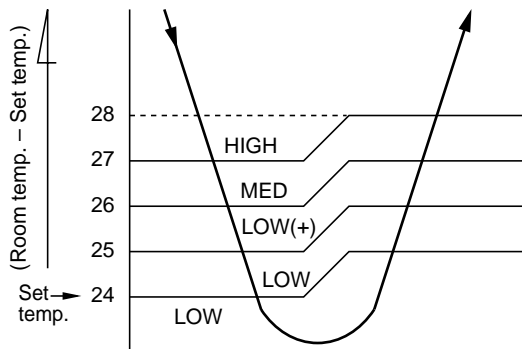

Fig. 7-1-1 Auto setting of air volume

Table 7-1-1 Manual setting of FAN SPEED

Indication of FAN SPEED	HIGH Air volume (m ³ /n)
LOW	400
MED	500
HIGH	600

- (2) Once the setting is made, the operation mode is memorized in the microcomputer so that the same operation can be effected thereafter simply by pushing the START/STOP button.

7-2. COOL Operation

(MODE of the remote control : COOL)

- (1) Compressor 4-way valve, outdoor fan and operation display are controlled as shown in Fig. 7-2-1.

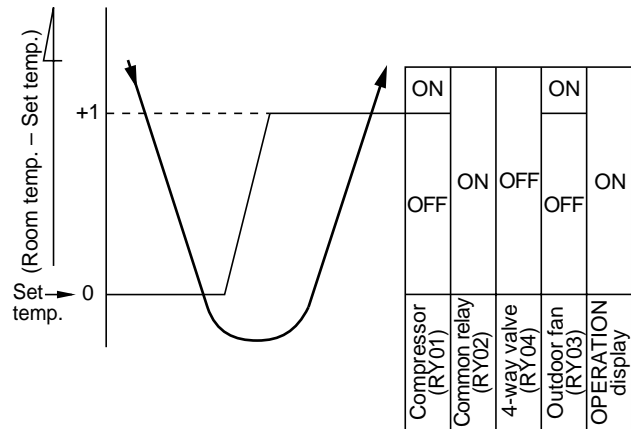

Fig. 7-2-1

- (2) Relays RY01 and RY02 are turned on to energize the outdoor unit, and a cool operation is carried out.
 - 1) When the FAN is set to AUTO, the indoor fan motor operates as shown in Fig 7-2-2.
 - 2) When the FAN is set to LOW, MED, or HIGH, the indoor fan motor operates with a constant in volume as listed in Table 7-1-1.

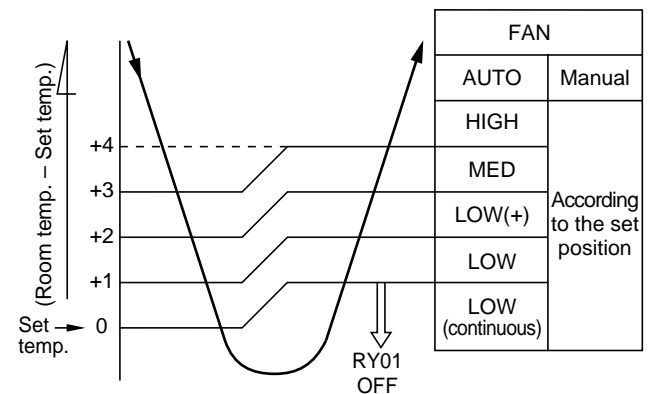

Fig. 7-2-2

- (3) Once the setting is made, the operation mode is memorized in the microcomputer so that the same operation can be effected thereafter simply by pushing the START/STOP button.

7-2-1. Louver Control

(1) By pushing the SET button of the remote control during the operation, the louver can be set to the desired position.

And the louver position is stored in the microcomputer, the louvers will be set to the position automatically at the next operation.

(2) When the AUTO button is pushed, the louver vertically swings within range of 25deg.

7-3. DRY Operation

(MODE of the remote control : DRY)

(1) Compressor 4-way valve, outdoor fan and operation display are controlled as shown in Fig. 7-3-1.

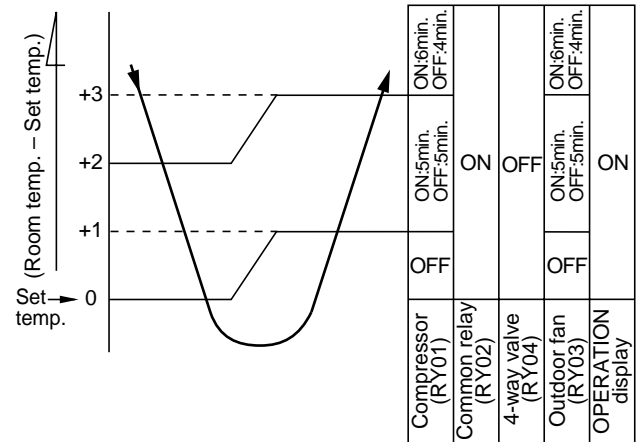

Fig. 7-3-1

- The microprocessor turns the compressor on and off at regular intervals (4 to 6 minutes on and/or off). During the compressor off, the indoor fan will operate in the super low position.
- The indoor fan will operate in the AUTO position.

(2) The pattern of operation depending on the relation between room temperature and set temperature is shown below:

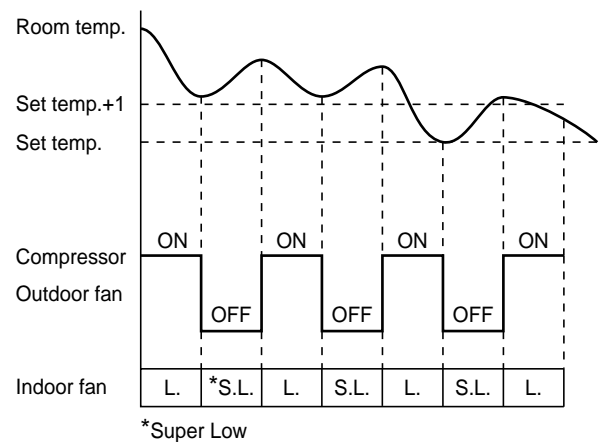

Fig. 7-3-2

7-4. HEAT Operation

(MODE of the remote control : HEAT)

- (1) Relays, 4-way valve, outdoor fan and operation display are controlled as shown in Fig. 7-4-1.

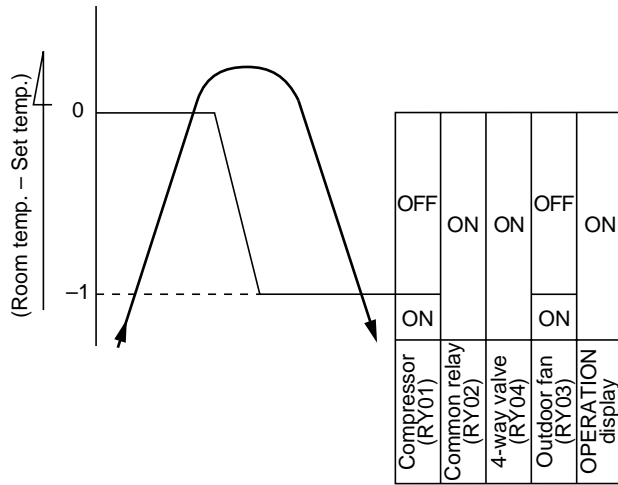

Fig. 7-4-1

- (2) Relays RY01 and RY02 are turned on to energize the outdoor unit, and a heat operation is carried out. The indoor fan motor operates as shown in Fig. 7-4-2, when the FAN is set to AUTO.

The motor operates with a constant air volume as listed in Table 7-1-1, when the FAN is set to LOW, MED, or HIGH.

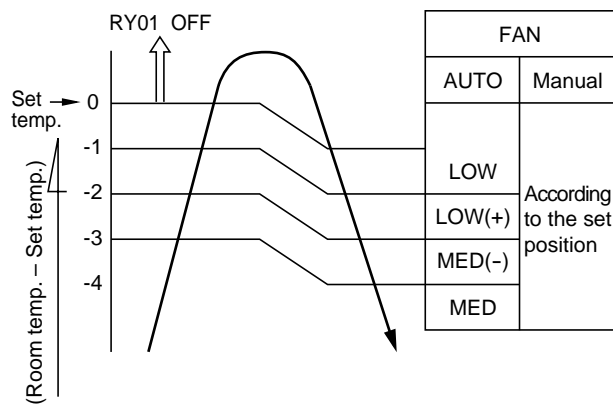

Fig. 7-4-2

- (3) Once the setting is made, the operation mode is memorized in the microcomputer so that the same operation can be effected thereafter simply by pushing the START/STOP button.

7-4-1. Louver Control

- (1) By pushing the SET button of the remote control during the operation, the louver can be set to the desired position.
- (2) When the AUTO button is pushed, the louver vertically swings within range of 25deg.

And the louver position is stored in the microcomputer, and at the next operation, the louvers will be set to the stored position automatically at the next operation.

7-4-2. Cool Airflow Control

- (1) If the indoor heat-exchanger temperature detected by the indoor heat-exchanger sensor is 20°C or below, the indoor fan stops and if the temperature rises to 25°C or above, the fan is restarted.

Details are in 7-10.

7-5. AUTO Operation

(MODE of the remote control : AUTO)

- (1) One of the 3 modes, Cooling, Fan only and Heating is selected according to room temperature at which operation is to start, as shown in Fig. 7-5-1. The Fan mode will continue until room temperature reaches a level at which another mode is selected.

7-5-1. Temporary Auto

When the TEMPORARY button is pushed, the set temperature is fixed at 24°C and controlled in accordance with the chart shown in Fig. 7-5-1.

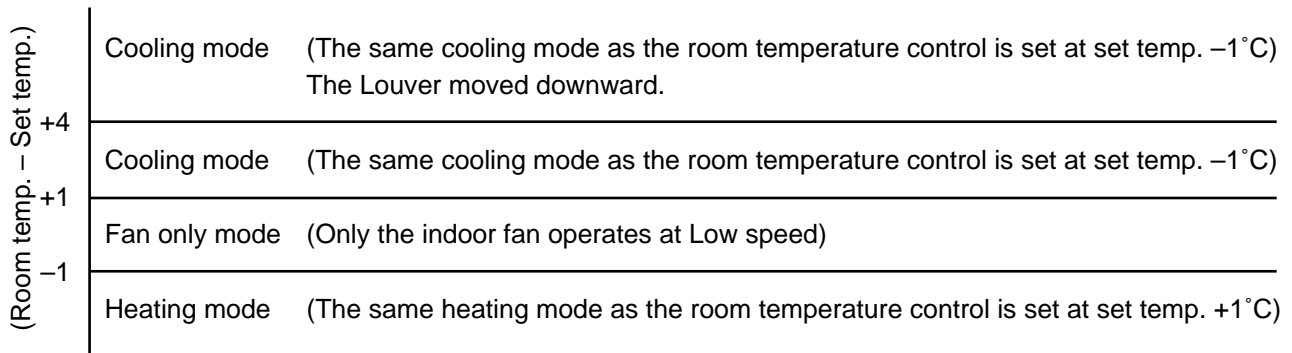

Fig. 7-5-1

7-6. ECONO. Mode

When the ECONO. button is pushed, during COOL, HEAT and AUTO operation, the OPERATION display is turned off and the ECONO. display is lit and the indoor unit operates quietly and mildly with controlling airflow.

7-6-1. Cooling

- (1) In the ECONO. mode, the set temp. by the remote control is changed automatically as shown in Fig. 7-6-1.
- (2) Fan speed → LOW

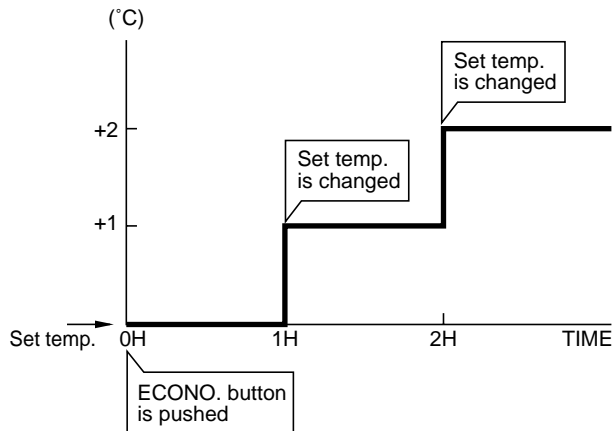

Fig. 7-6-1

7-6-2. Heating

- (1) In the ECONO. mode, the set temp. by the remote control is changed automatically as shown in Fig. 7-6-2.
- (2) Fan speed → LOW

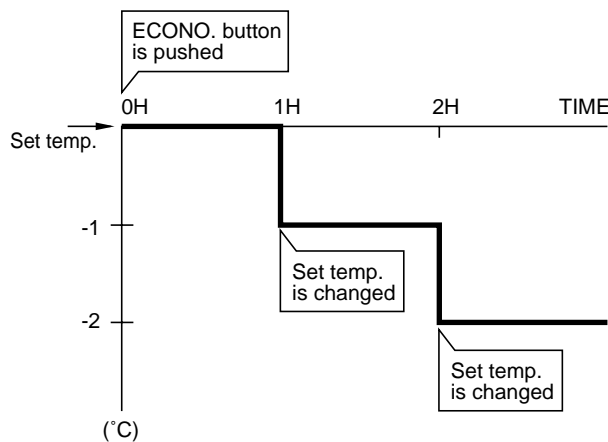

Fig. 7-6-2

7-7. Current Limit Control

The microprocessor detects the input current so as to prevent it exceeds a specified value by means of controlling the outdoor fan control as described in (1) and (2).

(1) Current limit control (Cooling)

Control is performed as shown below by detecting the compressor operation current with a current sensor (C.T).

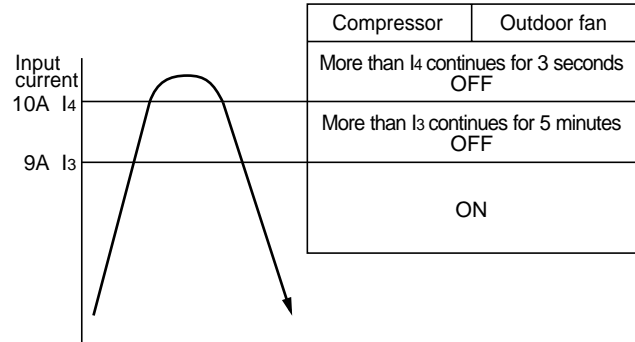

Fig. 7-7-1

(2) Current limit control (Heating)

Control is performed as shown in Fig. 7-7-2.

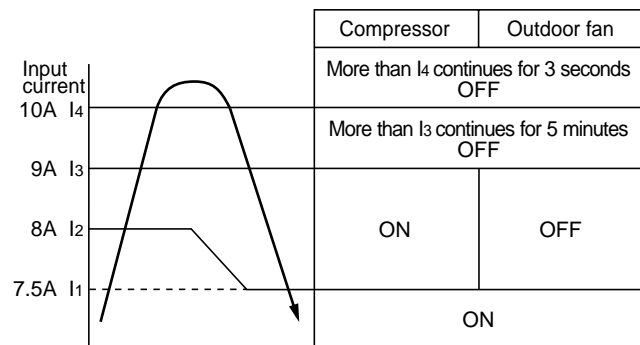

Fig. 7-7-2

7-8. High-Temperature Limit Control (Heating Operation)

The microprocessor detects the indoor heat exchanger temperature so as to prevent exceeding the condensate pressure.

Control is performed as shown in Fig. 7-8-1.

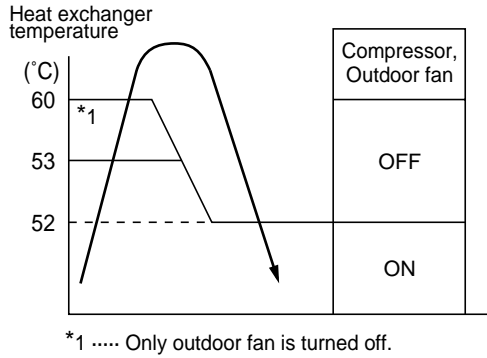

Fig. 7-8-1

7-10. Cool Airflow Prevention Control (Heating Operation)

(1) During the heating operation, the indoor fan speed is controlled automatically in accordance with the indoor heat exchanger temperature to prevent blowing the cool air.

Control is performed as shown in Fig. 7-10-1.

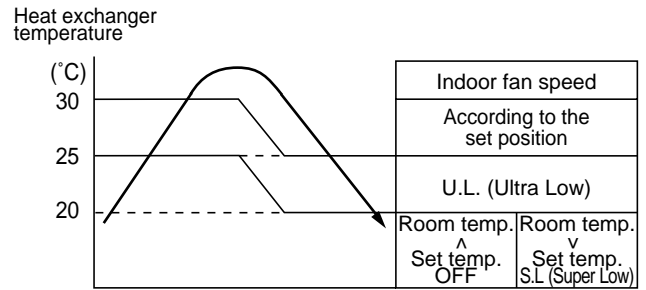

Fig. 7-10-1

7-9. Low-Temperature Limit Control (Cooling Operation)

The microprocessor detects the indoor heat exchanger temperature so as to prevent freezing up the indoor heat exchanger.

Control is performed as shown in Fig. 7-9-1.

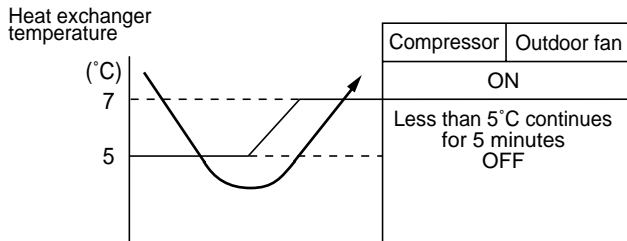

Fig. 7-9-1

(2) As soon as the defrost operation starts, the indoor fan stops.

7-11. Defrost Operation

During the heating operation, the outdoor heat exchanger temperature goes down and sometimes it is frozen.

In this case, the air conditioner stops the heating operation and starts the defrost operation to melt ice.

7-11-1. Condition to Start the Defrost Operation

The defrost operation starts whichever below conditions are specified.

- (1) When the cumulative compressor operation time is longer than 40 or 90 minutes and difference between the indoor heat exchanger temperature and the room temperature is less than the specified value. (This value is decided by the microprocessor.) (Control example is shown in Fig. 7-11-1. In case of B or C, the defrost operation starts.)
- (2) When the current limit control or the high temperature limit control is performed for total of 90 minutes.

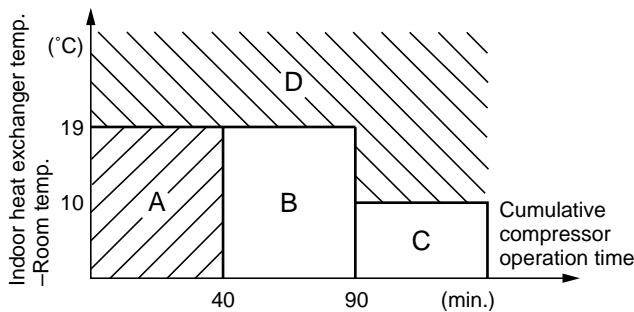

Fig. 7-11-1 (Indoor fan speed : M)

7-11-2. Defrost Operation Time Control

<In case of B>

- (1) The heating operation is performed for at least 40 minutes.
- (2) The maximum defrost operation time is 6 minutes. The defrost operation time for the 4th cycle is 10 minutes. (When the outdoor temperature is very low, however, the defrost operation time is 10 minutes.)

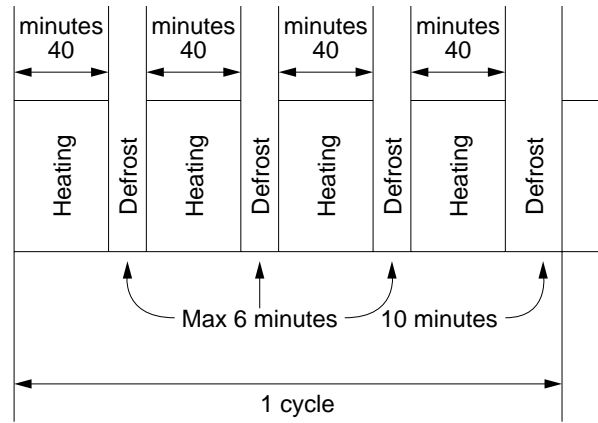

Fig. 7-11-2

<In case of C>

- (1) The heating operation is performed for at least 90 minutes.
- (2) The defrost operation time is 10 minutes.

7-11-3. Ending Condition at Defrost Operation

- (1) When the compressor current becomes 7.5A or more during defrost operation, the defrost operation stops and the heat operation restarts. (The current sensor detects the compressor current.)
- (2) The defrost operation continues for at most 6 minutes or 10 minutes.

DEFROST LAMP :

- During defrost operation, the PRE-DEF. lamp is on and the indoor and outdoor fans are off.
- The compressor start protection timer is interlocked with the PRE-DEF. lamp. So the PRE-DEF. lamp is off (the fans stop) for about 3 minutes after the START/STOP button is turned on. When the compressor is turned on, the PRE-DEF. lamp comes on. After the heat exchanger is preheated to about 30°C or higher, the PRE-DEF. lamp goes off, and the indoor fan starts.

7-12-2. How to Cancel the Auto Restart

To cancel the Auto Restart function, proceed as follows:

Repeat the setting procedure: the unit will acknowledge the instruction and beep three times.

The system will now be required to manually restart with the remote control after the main supply is turned off.

Cancellation is carried out:

- When the system is stand-by (not running)

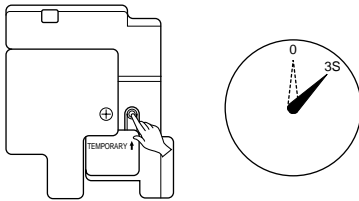
OPERATION	MOTION
<p>Press the TEMPORARY button continuously more than three seconds.</p> 	<p>Stand-by ↓ The system starts to operate. The orange light will be lit. about three seconds after ↓ The unit beeps three times. The green light will be lit. ↓ The system is operating.</p> <p>If the system is not required to run at this time, press the TEMPORARY button once more or use the remote control and the unit will stop.</p>

- When the system is operating

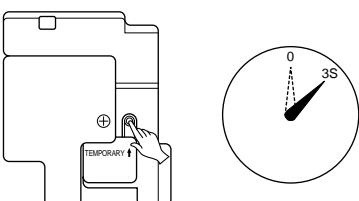
OPERATION	MOTION
<p>Press the TEMPORARY button continuously more than three seconds.</p> 	<p>Operating The orange light is lit. ↓ The system stops to operate. The orange light is turned off. about three seconds after ↓ The unit beeps three times. ↓ The system stops.</p> <p>If the system is not required to stop at this time, use the remote control and to restart.</p>

During subsequent operation, the green light is lighting.

7-12-3. In Case of Power Failure during the Timer Operation

(1) If ON-TIMER operation is reserved with setting of Auto Restart operation, it is cancelled with power failure. (The OPERATION lamp on the main unit goes on and off to inform of power failure.) In that case, try to reserve ON-TIMER operation once again.

(2) If OFF-TIMER operation is reserved without setting of Auto Restart operation, the reservation is cancelled with power failure. (The OPERATION lamp on the main unit goes on and off to inform of power failure.) In that case, try to reserve OFF-TIMER operation. When Auto Restart operation is set, OFF-TIMER reservation is also cancelled with power failure.

8. INSTALLATION PROCEDURE

8-1. Safety Cautions

For general public use

Power supply cord of parts of appliance for Outdoor use shall be more than polychloroprene sheathed flexible cord (design H05 RN-F), or cord designation 245 IEC 57.

CAUTION

TO DISCONNECT THE APPLIANCE FROM THE MAINS SUPPLY.

This appliance must be connected to the mains by means of a circuit breaker or a switch with a contact separation of at least 3 mm.

If this is not possible, a power supply plug with earth must be used. This plug must be easily accessible after installation. The plug must be disconnected from the power supply socket in order to disconnect the appliance completely from the mains.

DANGER

- ∨ FOR USE BY QUALIFIED PERSONS ONLY.
- ∨ TURN OFF MAIN POWER SUPPLY AND BREAKER BEFORE ATTEMPTING ANY ELECTRICAL WORK. MAKE SURE ALL POWER SWITCHES AND BREAKER TURN OFF. FAILURE TO DO SO MAY CAUSE ELECTRICAL SHOCK.
- ∨ CONNECT THE CONNECTING CABLE CORRECTLY. IF THE CONNECTING CABLE IS CONNECTED BY WRONG WAY, ELECTRIC PARTS MAY BE DAMAGED.
- ∨ CHECK THE EARTH WIRE IS NOT BROKEN OR DISCONNECTED BEFORE INSTALLATION.
- ∨ DO NOT INSTALL NEAR CONCENTRATIONS OF COMBUSTIBLE GAS OF GAS VAPORS. FAILURE TO FOLLOW THIS INSTRUCTION CAN RESULT IN FIRE OR EXPLOSION.
- ∨ TO PREVENT OVERHEATING THE INDOOR UNIT AND CAUSING A FIRE HAZARD, PLACE THE UNIT WELL AWAY (MORE THAN 2M.) FROM HEAT SOURCES SUCH AS RADIATORS, HEAT RESISTORS, FURNACE, STOVES, ETC..
- ∨ WHEN MOVING THE AIR-CONDITIONER FOR INSTALLING IT IN ANOTHER PLACE AGAIN, BE VERY CAREFUL NOT TO GET THE SPECIFIED REFRIGERANT (R-22) WITH ANY OTHER GASEOUS BODY INTO THE REFRIGERATION CYCLE. IF AIR OR ANY OTHER GAS IS MIXED IN THE REFRIGERANT, THE GAS PRESSURE IN THE REFRIGERATION CYCLE BECOMES ABNORMALLY HIGH AND IT RESULTINGLY CAUSES BURST OF THE PIPE AND INJURIES ON PERSONS.
- ∨ IN THE EVENT THAT THE REFRIGERANT GAS LEAKS OUT OF THE PIPE DURING THE INSTALLATION WORK, IMMEDIATELY LET FRESH AIR INTO THE ROOM. IF THE REFRIGERANT GAS IS HEATED BY FIRE OR SOMETHING ELSE, IT CAUSES GENERATION OF POISONOUS GAS.

WARNING

- Never modify this unit by removing any of the safety guards or by by-passing any of the safety interlock switches.
- Do not install in a place which cannot bear the weight of the unit.
Personal injury and property damage can result if the unit falls.
- Before doing the electrical work, attach an approved plug to the power supply cord.
And make sure the equipment to be earthed.
- Appliance shall be installed in accordance with national wiring regulations.
If you detect any damage, do not install the unit. Contact your Toshiba dealer immediately.

CAUTION

- Exposure of unit or water or other moisture before installation will result in an electrical short.
Do not store in a wet basement or expose to rain or water.
- After unpacking the unit, examine it carefully for possible damage.
- Do not install in a place that can increase the vibration of the unit. Do not install in a place that can amplify the noise level of unit or where noise and discharged air might disturb user's neighbors.
- To avoid personal injury, be careful when handling parts with sharp edges.
- Please read the installation manual carefully before installing the unit. It contains further important instructions for proper installation.

UK Plugs and Sockets etc (Safety) Regulations 1994 SI Number 1768

With regard to Schedule 3, Item 7 of the above UK Regulations, this appliance must be permanently connected to the fixed wiring of the main electrical supply by means other than the use of an approved 13 Amp plug-top as outlined in the Regulations.

Electrical work must be carried by suitably qualified persons and in accordance with all relevant safety standards and codes of practice.

We recommend that the power supply for this appliance is derived from a suitably protected dedicated circuit.
(for U.K. only)

8-2. Installation Diagram of Indoor and Outdoor Units

For installation of the indoor unit, use the paper pattern on the back.

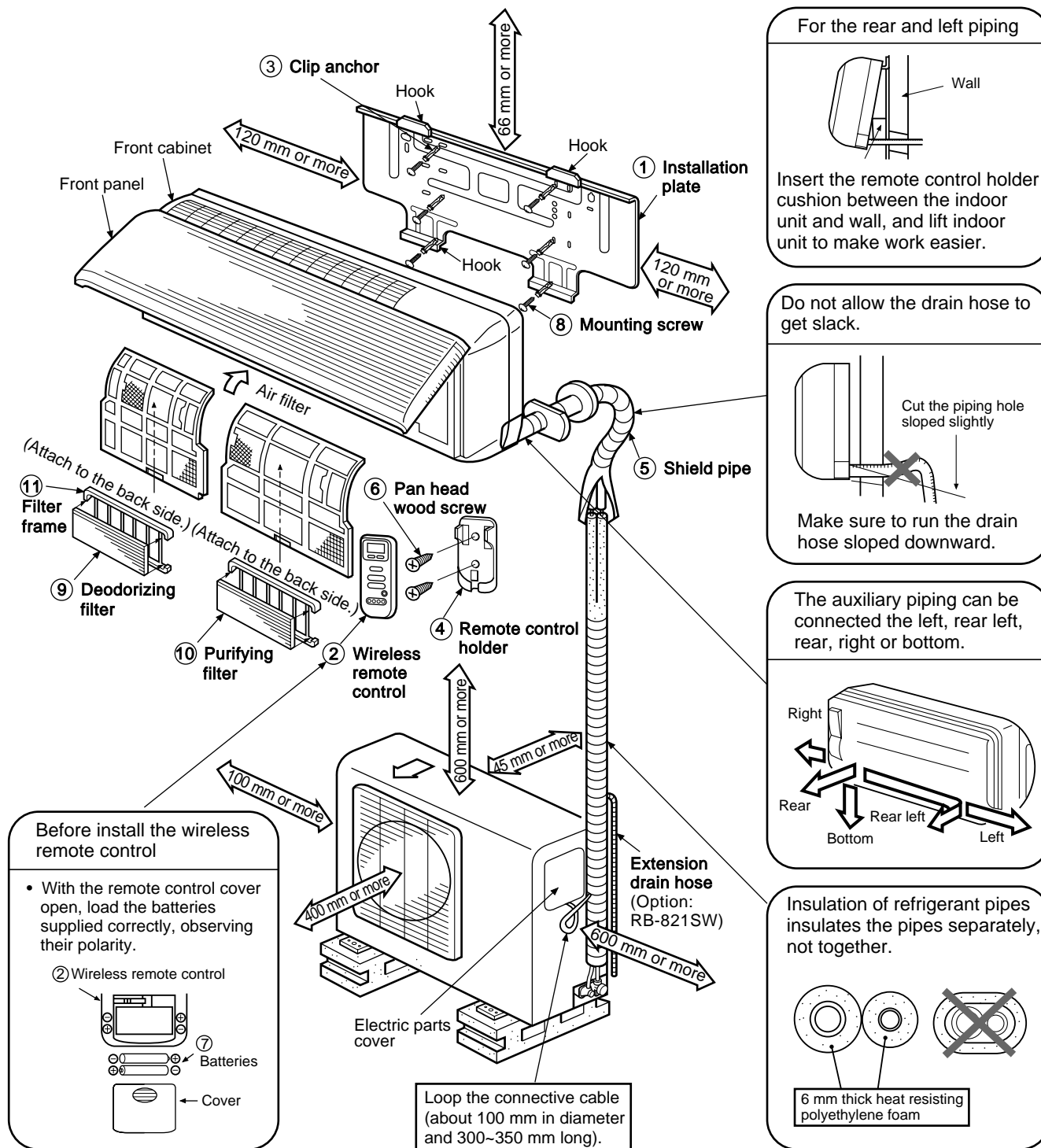

8-3. Installation

8-3-1. Optional Parts

Part code	Parts name	Q'ty
A	Refrigerant piping Liquid side : $\phi 6.35$ mm Gas side : $\phi 9.52$ mm	Each one
B	Pipe insulating material (polyethylene foam, 6 mm thick)	1
C	Putty, PVC tapes	Each one

<Anchor bolt arrangement of outdoor unit>

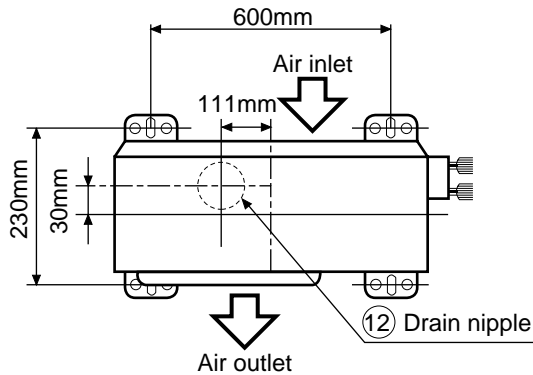

Fig 8-3-1 Air outlet

- Secure the outdoor unit with the anchor bolts if the unit is likely to be exposed to a strong wind.
- Use $\phi 8$ or $\phi 10$ anchor bolts.
- If it is necessary to drain the defrost water from the outdoor unit, attach ⑫ drain nipple to the bottom plate of the outdoor unit before installing it. The drain nipple is located as shown above.

<Drainage>

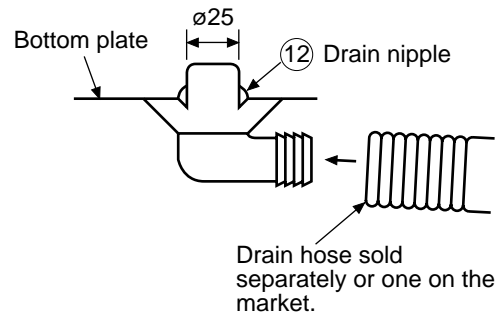
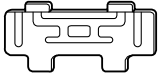
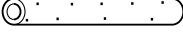
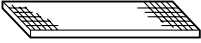

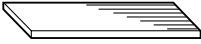

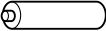





Fig 8-3-2

- Install the provided drain nipple in the hole of the bottom plate of the outdoor unit. (See the above figure.)
- Perform proper drainage processing using a drain hose sold separately or one on the market. (Inner diameter : 16 mm)
- Do not use an ordinary hose on the market, because it tends to get flat and as a result, it prevents water from draining.

8-3-2. Kit Parts

Parts with an asterisk (*) are packaged with the outdoor unit.

Part No.	Name of parts Q'ty	Part No.	Name of parts Q'ty	Part No.	Name of parts Q'ty
①	 Installation plate x 1	⑤	 Shield pipe x 1	⑨	 Deodorizing filter x 1
②	 Wireless remote control x 1	⑥	 Pan head wood screw ø3.1 x 16/ x 2	⑩	 Purifying filter x 1
③	 Clip anchor x 6	⑦	 Batteries x 2	⑪	 Filter frame x 2
④	 Remote control holder x 1	⑧	 Mounting screw ø4 x 25/ x 6	⑫	 Drain nipple* x 1

Others

Name
Installation manual
Owner's manual

This model is not equipped with an extension drain hose.

Option : For the extension drain hose, use an optionally available RB-821SW or commercially available one.

8-4. Indoor Unit

◆ Installation place

- A place which provides the spaces around the indoor unit as shown in the diagram in section 8-2.
- A place where there is no obstacle near the air inlet and outlet.
- A place which allows an easy installation of the piping to the outdoor unit.
- A place which allows the front panel to be opened.

CAUTION

- Direct sunlight to the indoor unit wireless receiver should be avoided.
- The microprocessor in the indoor unit should not be too close to r-f noise sources. (For details, see the owner's manual.)

<Remote control>

- A place where there are no obstacles such as a curtain that may block the signal from the remote control.
- Do not install the remote control in a place exposed to direct sunlight or close to a heating source, such as a stove.
- Keep the remote control at least 1 m apart from the nearest TV set or stereo equipment. (This is necessary to prevent image disturbances or noise interference.)
- The location of the remote control should be determined as shown below.

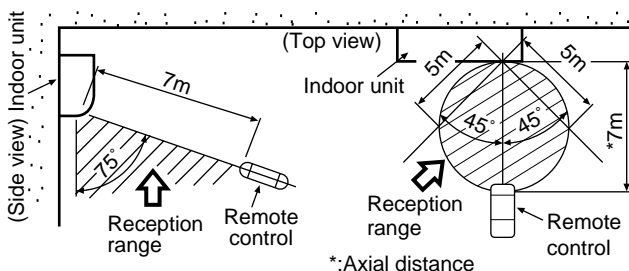

Fig. 8-4-1

8-4-1. Cutting a Hole and Mounting Installation Plate

<Cutting a hole>

When installing the refrigerant pipes from the rear

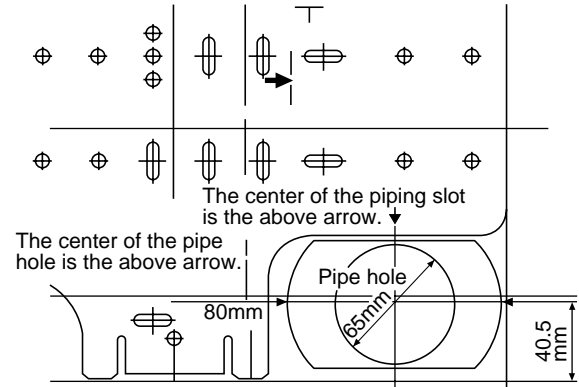

Fig. 8-4-2

- (1) After determining the pipe hole position with the mounting plate (80 mm →), drill the pipe hole (ø65 mm) at a slight downward slant to the outdoor side.

NOTE :

- When drilling the wall that contains a metal lath, wire lath or metal plate, be sure to use a pipe hole brim ring sold separately.

<Mounting the installation plate>

For installation of the indoor unit, use the paper pattern on the back.

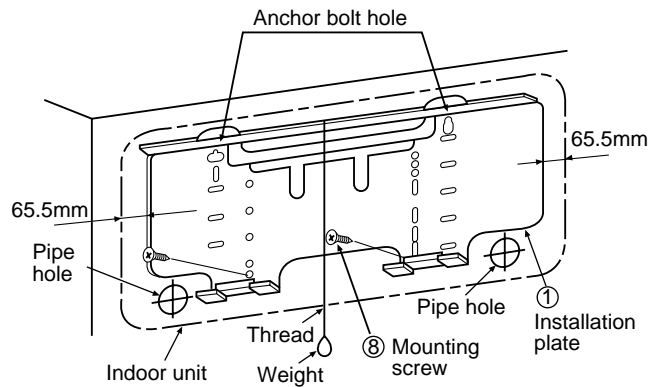

Fig. 8-4-3

<When the installation plate is directly mounted on the wall>

- (1) Securely fit the installation plate onto the wall by screwing it in the upper and lower parts to hook up the indoor unit.
- (2) Install the installation plate horizontally in the wall.
- (3) To mount the installation plate on a concrete wall with anchor bolts, utilize the anchor bolt holes as shown in the above figure.

CAUTION

When installing the installation plate with mounting screw, do not use the anchor bolt hole. Otherwise the unit may fall down and result in personal injury and property damage.

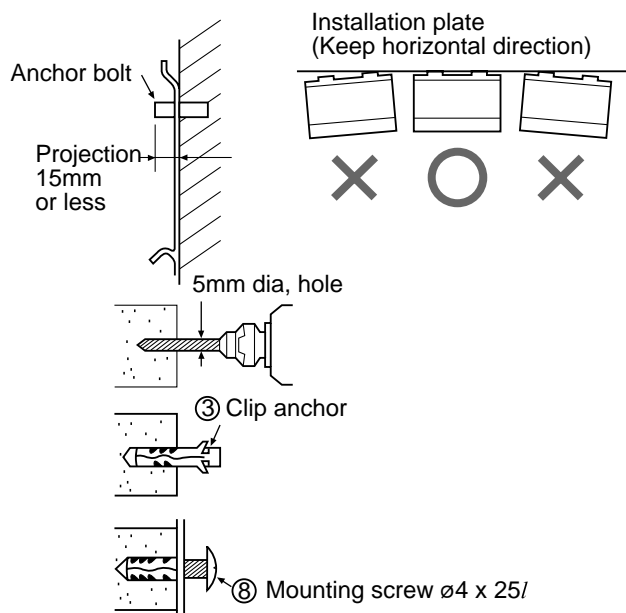

Fig. 8-4-4

CAUTION

Failure to firmly install the unit may result in personal injury and property damage if the unit falls.

- In case of block, brick, concrete or similar type walls, make 5 mm dia, holes in the wall.
- Insert ③ clip anchors for appropriate ⑧ mounting screws.

NOTE :

- Install the installation plate using 4 to 6 pieces of mounting screw securing four corners with screws.

8-4-2. Electrical Work

- (1) The supply voltage must be the same as the rated voltage of the air conditioner.
- (2) Prepare the power source for exclusive use with the air conditioner.

Model	Power source	Maximum running current	Plug socket & fuse rating	Wiring
RAS-10SKH-E/ 10SAH-E RAS-10SKHX/ 10SAHX	50Hz *220/230/240V~ Single-phase	7.5 A	15 A	1mm ² or more

* No adjustment is necessary.

CAUTION

- Use power specified in above table.
- This appliance can be connected to the mains in either of the following two ways.
 - (1) Connecting the power cord to the main power supply provided with a circuit breaker or switch with a contact of 3 mm or more.
In this case, an approved circuit breaker or switch must be used.
 - (2) Attaching a plug to the power cord and plugging it in to the wall outlet.
In this case, an approved power cord and plug must be used.

NOTE :

- Perform wiring works so as to allow a generous wiring capacity.

8-4-3. Wiring Connection

WARNING

To plug the cable in the plug receptacle, take the following precaution.

THIS APPLIANCE MUST BE EARTHED.

IMPORTANT

THE WIRES IN THIS MAINS LEAD ARE COLORED IN ACCORDANCE WITH THE FOLLOWING CODE:

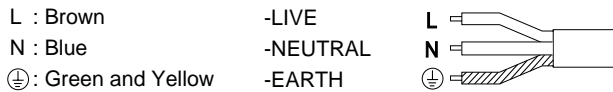

Fig. 8-4-5

As the colors of the flexible cord of this appliance may not correspond with the colored markings, to identify terminals in your plug, as follows:

Connect BROWN colored core to plug terminal marked letter "L".

Connect BLUE colored core to plug terminal marked letter "N".

Connect GREEN AND YELLOW colored core to plug terminal marked Earth Symbol "⊕".

<How to remove the front cabinet>

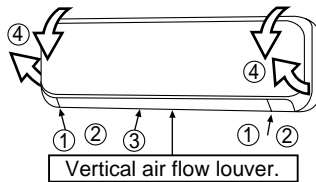

Fig. 8-4-6

How to open the screw cap



- Place your finger on the lower part and push up to open the screw cap.

- (1) Open the screw caps and remove the two screws securing the front cabinet.
- (2) Close the screw caps as behind.
- (3) Open the vertical airflow louver horizontally by hand.
- (4) Slightly open the lower part of the front cabinet then pull the upper part of the front cabinet toward you to remove it from the rear plate.

Taking out the power cord

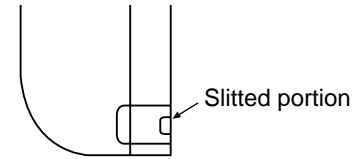

- Cut off the slitted portion in the side face of the rear panel to take out the power cord. After this, remove burrs, sharp edges, etc., to smooth the cut face.

<How to connect the power cord>

For the air conditioner that has no power cord, connect a power cord to it as mentioned below.

- After removing the front cabinet, remove the terminal cover and the cord clamp.
- Connect and secure the power supply cord and secure the cord clamp and the terminal cover.
- Cut the rear panel following the cutting mark and put the power supply cord through the notch.
- Be sure to smooth out the notch with a file, etc.

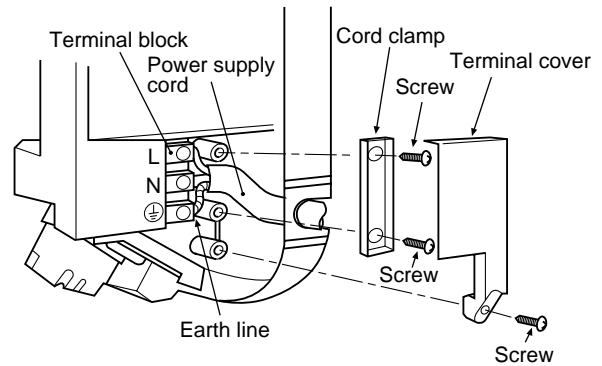
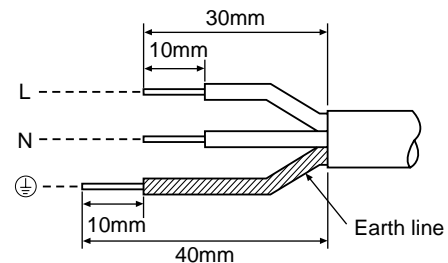

Fig. 8-4-7

<Stripping length of power cord>



NOTE :

- Use standard wire only.
- Wire type: More than H05-RNF

Fig. 8-4-8

<How to connect the connecting cable>

Wiring of the connecting cable can be carried out without removing of the front panel.

- (1) Remove the front panel.
Fully open the front panel. Disengage the support arm located in the upper center while pushing its handle leftwards, and then remove the front panel toward you.
- (2) Remove the terminal cover and cord clamp.
- (3) Insert the connecting cable (according to local codes) into pipe hole on the wall.
- (4) Take out the connecting cable through the cable slot on the rear panel so that it is exploded by about 15 cm long in the front side.
- (5) Insert the connecting cable fully into the terminal block and secure it by screw tightly.
- (6) Tightening torque: 1.2 N•m (0.12 kgf•m)
- (7) Secure the connecting cable with the cord clamp.
- (8) Fix the terminal cover and front panel on the indoor unit.

CAUTION

- Be sure to refer the wiring system diagram labeled inside the front panel.
- Check local electrical codes and also any specific wiring instructions or limitation.

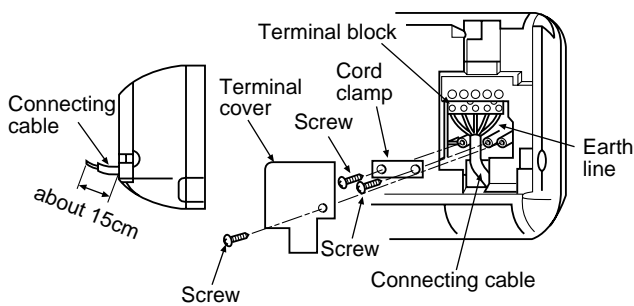
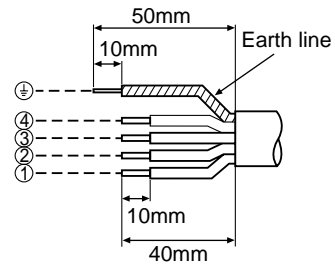

Fig. 8-4-9

<Stripping length of connecting cable>



For a five conductor cable

NOTE :

- Use stranded wire only.
- Wire type: More than H05 RN-F

Fig. 8-4-10

<How to install the front cabinet on the indoor unit>

Install the front cabinet through the opposite order of "How to remove the front cabinet".

When the panel is removed and mounted again, take the following actions:

After fastening the two screws, one each at the left and right of the air outlet, be sure to push the upper center ① right end ②, left end ③ and the lower center ④ of the air outlet, and confirm that no gap is left between the front cabinet and the rear plate.

- If cooling (dry) operation is made without pushing the air outlet, dew can be deposited on the front cabinet surface. In addition a gap between the front cabinet and the rear plate will become wider, spoiling the appearance.

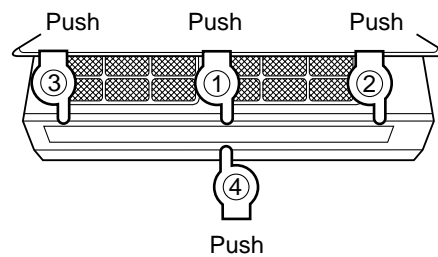

Fig. 8-4-11

8-4-4. Piping and Drain Hose Installation

<In case of rightward piping>

- After scribing slits of the front panel and the rear panel by a knife or a marking-off pin, cut them by a pair of nippers or the like.

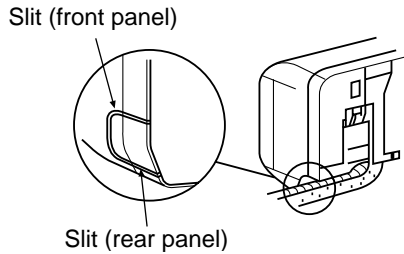

Fig. 8-4-12

<In case of downward piping>

- After scribing the slit of the front panel and slit in the lower part of the rear panel by a knife or a marking-off pin, cut them by a pair of nippers or the like.

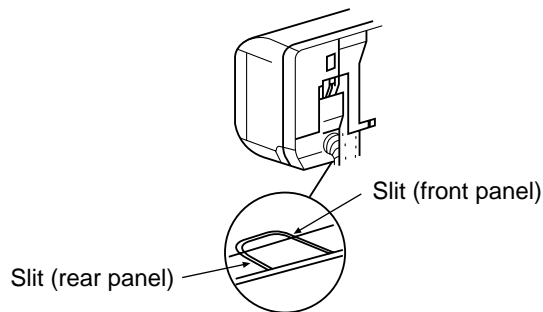

Fig. 8-4-13

<Left-hand connection with piping>

Bend the connecting pipe so that it is laid within 43 mm above the wall surface. If the connecting pipe is laid exceeding 43 mm above the wall surface, the indoor unit may unstably be set on the wall. When bending the connecting pipe, make sure to use spring bender so as not to crush the pipe.

Bend the connection pipe within a radius of 30 mm.

To connect pipe after installation of unit (figure)

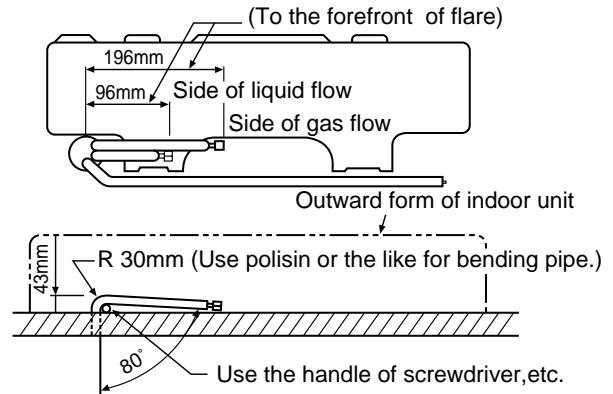

Fig. 8-4-14

NOTE :

If the pipe is bent incorrectly, the indoor unit may unstably be set on the wall.

After passing the connecting pipe through the pipe hole, connect the connecting pipe to auxiliary pipes and wrap the facing tape around them.

CAUTION

- Bind the auxiliary pipes (two) and connecting cable with facing tape tightly. In case of leftward piping and rear-leftward piping, bind the auxiliary pipes (two) only with facing tape.



- Carefully arrange pipes so that any pipe does not stick out of the rear plate of the indoor unit.
- Carefully connect the auxiliary pipes and connecting pipes to each other and cut off the insulating tape wound on the connecting pipe to avoid double-taping at the joint, moreover, seal the joint with the vinyl tape, etc.
- Since dewing results in a machine trouble, make sure to insulate both the connecting pipes. (Use polyethylene foam as insulating material.)
- When bending a pipe, carefully do it not to crush it.

8-4-5. Indoor Unit Installation

- (1) Pass the pipe through the hole in the wall, and hook the indoor unit on the installation plate at the upper hooks.
- (2) Swing the indoor unit to right and left to confirm that it is firmly hooked up on the installation plate.
- (3) While pressing the indoor unit onto the wall by the lower part, hook it up on the installation plate by the lower part. Pull the indoor unit toward you by the lower part to confirm that it is firmly hooked up on the installation plate.

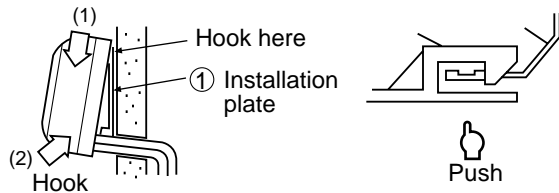

Fig. 8-4-15

- For detaching the indoor unit from the installation plate pull the indoor unit toward you while pushing its bottom up by the specified parts.

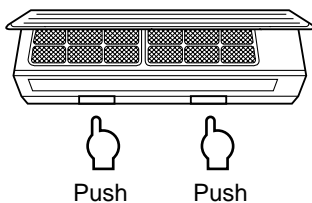

Fig. 8-4-16

8-4-6. Drainage

- (1) Run the drain hose sloping downwards.

NOTE :

- Hole should be made at a slight downward slant to the outdoor side.

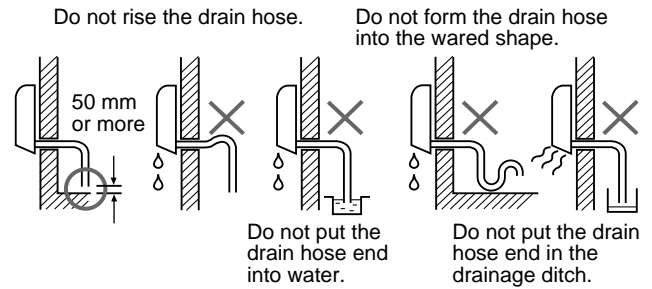

Fig. 8-4-17

- (2) Put water in the drain pan and make sure that the water is drained outdoors.
- (3) When connecting extension drain hose, insulate the connecting part of extension drain hose with ⑤ shield pipe.

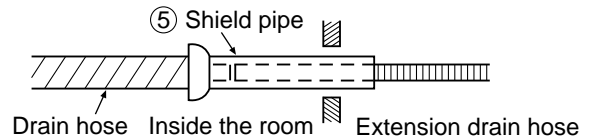

Fig. 8-4-18

CAUTION

Arrange the drain pipe for proper drainage from the unit.

Improper drainage can result in damage to property.

This air conditioner has the structure designed to drain water collected from dew, which forms on the back of the indoor unit, to the drain pan.

Therefore, do not store the power cord and other parts at a height above the drain guide.

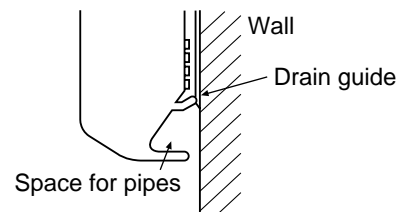

Fig. 8-4-19

8-5. Outdoor Unit

◆ Installation place

- A place which provides the spaces around the outdoor unit as shown in the diagram in page 23.
- A place which can bear the weight of the outdoor unit and does not allow an increase in noise level and vibration.
- A place where the operation noise and discharged air do not disturb your neighbors.
- A place which is not exposed to a strong wind.
- A place free of a leakage of combustible gases.
- A place which does not block a passage.
- When the outdoor unit is to be installed in an elevated position, be sure to secure its feet.
- An allowable length of the connecting pipe is up to 10 m.
- An allowable head level is up to 5 m.
- A place where the drain water does not raise any problem.

CAUTION

- (1) Install the outdoor unit without anything blocking the air discharging.
- (2) When the outdoor unit is installed in a place exposed always to a strong wind like a coast or on a high story of a building, secure the normal fan operation using a duct or a wind shield.
- (3) Specially in windy area, install the unit to prevent the admission of wind.

CAUTION

Installation in the following places may result in trouble. Do not install the unit in such places.

- A place full of machine oil.
- A saline place such as coast.
- A place full of sulfide gas.
- A place where high-frequency waves are likely to be generated as from radio equipment, welders, and medical equipment.

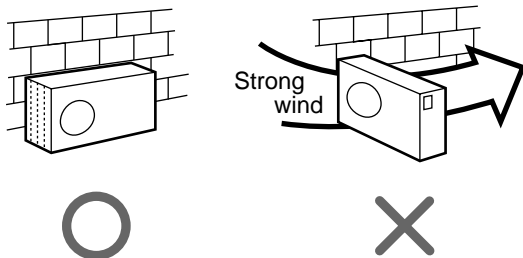

Fig. 8-5-1

8-5-1. Refrigerant Piping Connection

<Flaring>

(1) Cut the pipe with a pipe cutter.

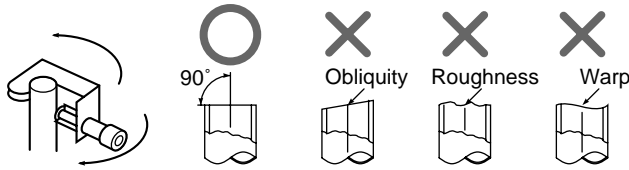

Fig. 8-5-2

(2) Insert a flare nut into the pipe, and flare the pipe.

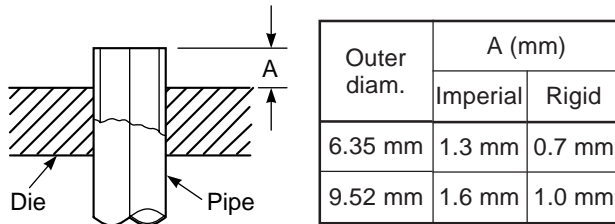

Fig. 8-5-3

<Tightening connection>

Align the centers of the connecting pipes and tighten the flare nut as far as possible with your fingers. Then tighten the nut with a spanner and torque wrench as shown in the figure.

CAUTION

- Do not apply excess torque. Otherwise, the nut may crack depending on the installation conditions.

(Unit : N·m)

Outer diam.	Tightening torque	Additional tightening torque
6.35 mm	15.7 (1.6 kgf·m)	19.6 (2.0 kgf·m)
9.52 mm	29.4 (3.0 kgf·m)	34.3 (3.5 kgf·m)

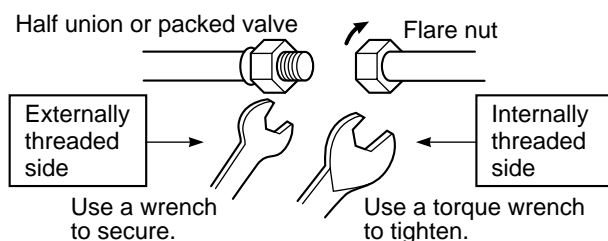

Fig. 8-5-4

8-5-2. Vacuum Pumping

AIR PURGE

Evacuate the air in the connecting pipes and in the indoor unit using vacuum pump.

Do not use the refrigerant in the outdoor unit.

For details, see the manual of vacuum pump.

<Use of vacuum pump>

- Connect the charge hose (A) from the manifold valve to the charge inlet of the gas side packed valve.
- Connect the charge hose (B) to the port of vacuum pump.
- Open fully the low pressure side handle of the manifold valve.
- Operate the vacuum pump.
- Close the low pressure side handle of manifold valve after vacuumizing and stop the vacuum pump.

Continue vacuumizing more than 15 minutes and check the pressure gauge indicates -76 cmHg.

- Open the stems of packed valves A and B all the way.
- Securely tighten the stem cap to each of the packed valve stems.

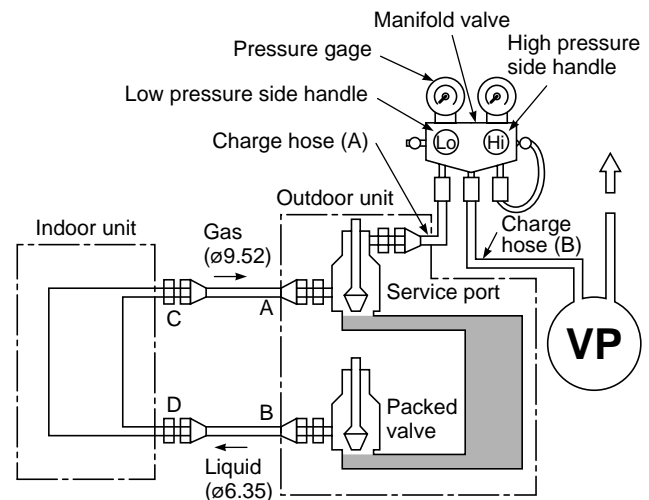

Fig. 8-5-5

CAUTION

- KEEP IMPORTANT 4 POINTS FOR INSTALLATION (PIPING WORK)
- (1) Take away dust and moisture (Inside of the connecting pipes.)
 - (2) Tight connection (between pipes and unit)
 - (3) Evacuate the air in the connecting pipes using VACUUM PUMP.
 - (4) Check gas leak (connected points)

<Packed Valve Handling Precautions>

- Open the valve stem all the way out; so not try to open it beyond the stopper.
- Securely tighten the valve stem cap with the wrench or like.
- Valve stem cap tightening torque is as follows;
Gas pipes side (ø9.52) : 29.4 N•m (3.0 kgf•m)
Liquid pipe side (ø6.35) : 16.2 N•m (1.7 kgf•m)

<A5 mm hexagon wrench is required.>

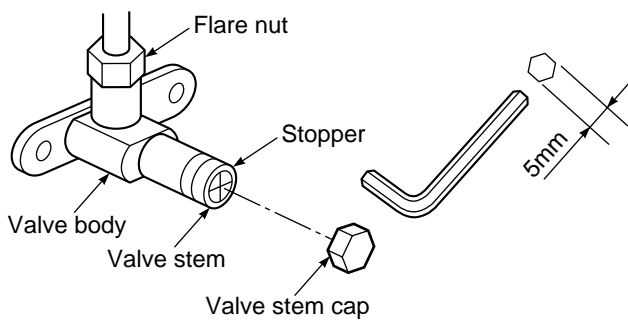

Fig. 8-5-6

8-5-3. Wiring Connection

- (1) Remove the electric parts cover from the outdoor unit. (1 screw)
- (2) Connect the connecting cable to the terminals as identified with their respective matched numbers on the terminal block of indoor and outdoor units. (Strip the sheath of connecting cable with following stripping length to and insert into the terminal block.)
- (3) When connecting the connecting cable to outdoor unit terminal, make a loop as shown in the installation diagram of indoor and outdoor unit, to prevent water coming in the outdoor unit.
- (4) Insulate the unused cords (conductors) with water coming in the outdoor unit. Process them so that they do not touch any electrical or metal parts.

<Stripping length of connecting cable>

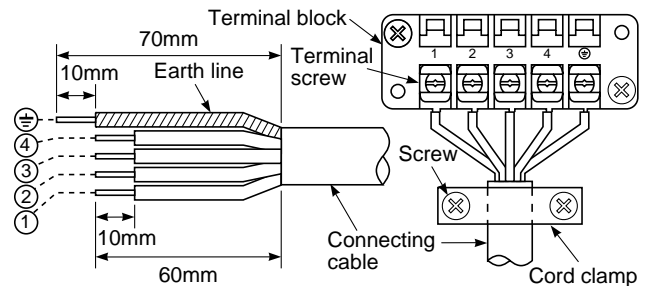

Fig. 8-5-7

CAUTION

- Wrong wiring connections may cause some electrical parts to burn out.
- Be sure to comply with local code on running the wire from the indoor unit to outdoor unit. (size of wire and wiring method etc.)
- Every wire must be connected firmly.

NOTE :

- Wipe type : More than H05 RN-F

8-6. Others

8-6-1. Gas Leak Test

Flare nut connections (Indoor unit)

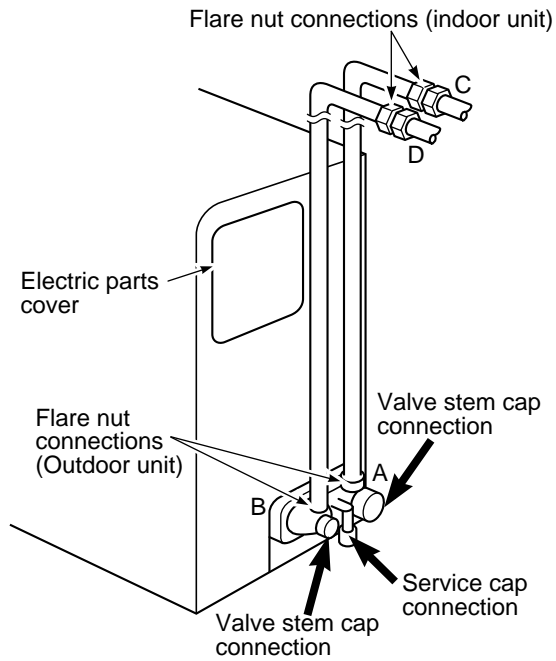

Fig. 8-6-1

- Check the flare nut connections, valve stem cap connections and service cap connections for gas leak with a leak detector or soap water.

8-6-2. Test Operation

To switch the TEST RUN (COOL) mode, press TEMPORARY button for 10 sec. (The beeper will make a short beep.)

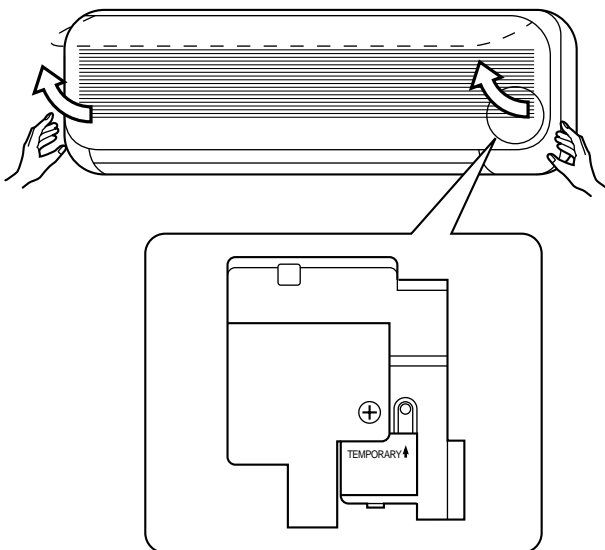

Fig. 8-6-2

8-6-3. Auto Restart Setting

This product is designed so that, after a power failure, it can restart automatically in the same operating mode as before the power failure.

Information

The product was shipped with Auto Restart function in the off position. Turn it on as required.

<How to set the Auto Restart>

- Press and hold down the TEMPORARY button for about 3 seconds. After 3 seconds, the electronic beeper makes three short beeps to tell you the Auto Restart has been selected.
- To cancel the Auto Restart, follow the steps described in the section Auto Restart Function of the User's Manual.

9. TROUBLESHOOTING CHART

TROUBLESHOOTING PROCEDURES :

- Following details of “What to be pre-checked first”, make sure of the basic items.
- When there is no trouble corresponding to above, check in detail the faulty parts following “How to judge faulty parts by symptoms” later.

9-1. What to be Prechecked First

9-1-1. Power Supply Voltage

The line voltage must be AC 220/230/240V. If the line voltage is not within this range, this air conditioner may not work normally.

9-1-2. Incorrect Cable Connection between Indoor and Outdoor Units

The indoor unit is connected to the outdoor unit with 5 cables. Make certain that the indoor and outdoor units have been connected properly, with terminals assigned the same numbers wired to each other. If the connectors are not connected as specified, the outdoor unit will not operate normally, or OPERATION lamp and TIMER lamp will flash (5Hz).

9-1-3. Misleading but Good Operations (Program Controlled Operation)

The microcomputer performs the operations listed in Table 9-1-1 to control the air conditioner. If a claim is made on the operation, check whether it corresponds

to the contents in the Table 9-1-1. If it does, it is an indispensable operation for the control and maintenance of the air conditioner: it is not a failure of the unit.

Table 9-1-1

No.	Operation of air-conditioner	Description
1	When the power plug or the power cord of the indoor unit is inserted, the OPERATION lamp on the setting indication part flashes.	The OPERATION lamp flashes, indicating that power is turned on. If this happens, push the START/STOP button once to cause the lamp to stop flashing. A power outage also causes the lamp to flash.
2	Fan speed remains unchanged in the dry mode.	Fan speed is automatically controlled in the dry mode.
3	Room temperature is in the range under which the compressor is turned off, but the compressor will not stop.	The compressor will not stop while the compressor on hold timer (3-minutes timer) is actuated.
4	The compressor will not switch on or off even when the thermo control is operated in the dry operation.	In the dry mode, the compressor goes on and off at regular intervals, independent of the thermo control.
5	The PRE-DEF. lamp comes on when the heating operation is started.	The PRE-DEF. lamp comes on during defrost operation and when the indoor heat exchanger temperature is low when the heating operation is started. At this time, the indoor fan is stopped to prevent cold air from drifting into the room.
6	The outdoor fan stops once in the while during the heating operation.	<ul style="list-style-type: none"> • When the indoor heat exchanger temperature is high, the outdoor fan may be stopped by the high-temperature limit control operation. • When the compressor current is large, the outdoor fan may be stopped by the current limit control operation.
7	Compressor does not work though room temperature is in the range of turning the compressor on.	Compressor does not work while the compressor restart delay (3-min.) timer is active. The same is true after power is turned on, as the time is still active.
8	During automatic operation, the operation mode changes.	After selection of the cooling and heating operation, the operation mode is selected again when the compressor off mode continues for 15 min. according to the room temperature.
9	During automatic operation mode, the fan only operation continues.	When the room temperature is within setting temperature $\pm 1^{\circ}\text{C}$ the fan only mode is selected.
10	When the power is turned on, the operation starts automatically.	When the auto restart controlling is selected, the operation is performed automatically in the previous operation mode after the power supply has been turned on.

9-2. Primary Judgement of Trouble Sources

9-2-1. Role of Indoor Unit Controller

The indoor unit controller receives the operation commands from the remote control and assumes the following functions.

- Measurement of the draft air temperature of the indoor heat exchanger by using the thermo sensor (TA).
- Louver motor control
- Control of the indoor fan motor operation
- Control of the LED display
- Control of the outdoor unit compressor, 4WAY-VALVE and the outdoor fan motor.

9-2-2. Display of Abnormalities and Judgement of the Abnormal Spots

The indoor unit of this machine observes the operation condition of the air conditioner and displays the contents of the self-diagnosis as block displays on the display panel of the indoor unit.

Table 9-2-1

	Block display	Block display
A	OPERATION display flashing (1 Hz)	Power failure (when power is ON)
B	OPERATION display flashing (5 Hz)	Thermo sensor (TA) short/break
C	OPERATION display flashing (5 Hz)	Heat exchanger sensor (TC) short/break
D	OPERATION display flashing (5 Hz)	Indoor fan lock, abnormality of indoor fan
E	OPERATION display flashing (5 Hz)	Indoor PC board failure
F	OPERATION and TIMER display flashing (5 Hz)	Wrong wiring of connecting cable Thermal fuse is blown
G	OPERATION, TIMER and PRE-DEF. display flashing (5 Hz)	<ul style="list-style-type: none"> • Gas shortage, other refrigerant cycle trouble • Heat exchanger sensor open/break/short • Overload relay trouble
H	OPERATION, TIMER and PRE-DEF. display flashing (5 Hz)	Compressor trouble

(1) Judgement from defective operation or abnormal operation

Table 9-2-2

Symptom	Check		Primary judgement
No reaction on remote control operation	Turn off the power once, turn it on again and try to operate the remote control again.	Remote control is not possible.	The indoor part (including the remote control) is defective.
		Remote control is possible.	OK.
The outdoor fan does not rotate	The compressor operates.		The outdoor part is defective. (outdoor fan motor)
	The compressor does not operate.		The inside part is defective.

(2) Self-diagnosis with remote control

With the indoor unit control, self-diagnosis of protective circuit action can be done by turning the remote control operation into service mode, operating the remote control, observing the remote control indicators and checking whether TIMER lamp flashes (5 Hz).

Note :

- To perform this self-diagnosis, the remote control with the service code of 43069666 is required.

<How to select remote control operation mode>

1) Selecting service mode

Push the switch button provided on rear bottom of the wireless remote control with a tip of pencil for more than 3 seconds. Make sure the setting temperature “□□” is displayed on the display and other display is turned off.

2) Selecting ordinary mode

Push the all clear button (ACL) on the rear bottom of the wireless remote control with a tip of pencil for more than 3 seconds. Make sure the operation mode display, wind volume display, clock display and setting temperature display are turned on and “:” of the clock display is flashing.

<Cautions when doing service>

- 1) After completion of servicing, always push the all clear (ACL) button to return the operation mode to the normal mode.
- 2) After completion of servicing by the check code, turn off the power once and then turn on the power to reset memorized contents of the microcomputer to the initial status.

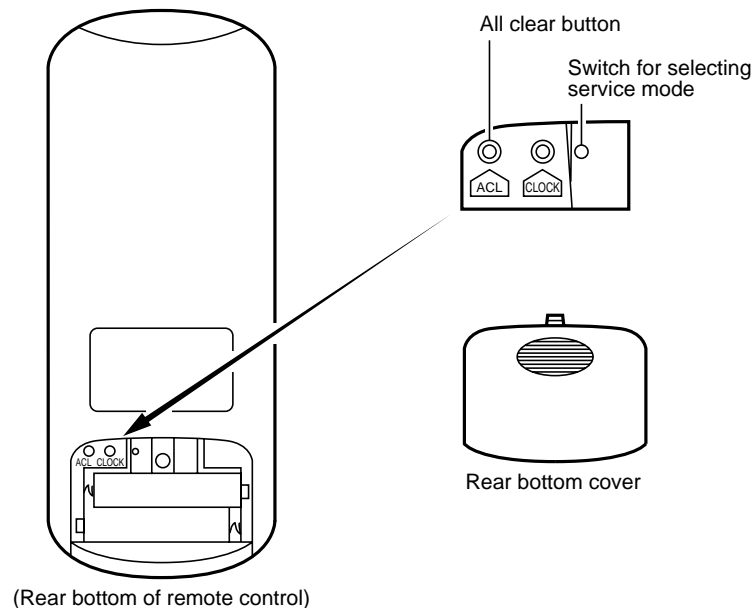

Fig. 9-2-1

<Self-diagnosis by check codes>



- 1) The self-diagnosis by the check codes is conducted under the block displays of item B-H in Table 9-2-1.
- 2) Remote control key operation under the service mode is conducted by ON/OFF or TEMP. The remote control display by each key operation is varied as shown below. Two digit number is displayed in a hexadecimal number.
- 3) The self-diagnosis by the check codes is conducted with procedures shown below.
 - a) Enter the service mode and make sure the off timer display of the remote control shows "00".
 - b) Operate the "ON/OFF" key and make sure the timer lamp on the display section is flashing (5 Hz).
 - c) At the same time, also make sure the operation lamp is also flashing. This shows that the protection circuit on the indoor PC board is working.
 - d) Operate the TEMP.  key and make sure the remote control display shows "01" and flashing of the operation lamp. If the operation lamp is flashing, it shows the protection circuits for connecting cable is working or thermal fuse is blown.
 - e) In the same way, operate the TEMP.  key so that the display is increased one by one to continue checks by the self-diagnosis as shown in the next table. From "00" up to "03" check operations of protection circuits for each block, and "04" to "1F" check operations of the typical protection circuits.

Table 9-2-3



Operating key	Indication after operation
ON/OFF	"00"
TEMP.  (Up)	1 is added to data before operation. (Example) "02" → "03"
TEMP.  (Down)	1 is subtracted from data before operation. (Example) "02" → "01"
"AUTO" LOUVER	10 is subtracted from data before operation. (Example) "02" → "12"
"SET" LOUVER	Data before operation is directly transferred. (Example) "02" → "02"

Table 9-2-4

Block level		Diagnosis function				Judgment and action
Check code	Block	Check code	Symptom	Air Conditioner status	Condition	
00	Indoor PC board	01	Thermo sensor short/break.	Continued operation	Indicated when detected abnormal	1. Check thermo sensor. 2. If it is OK, check PC board.
		02	Heat exchanger sensor short/break.	Continued operation	Indicated when detected abnormal	1. Check heat exchanger sensor. 2. If it is OK, check PC board.
		11	Indoor fan lock, abnormality of indoor fan.	All off	Indicated when detected abnormal	1. Disconnect the power plug from AC outlet, and pull out the connector (CN10) for the motor, then connect the plug of AC power cord again and turn the power on. 2. Check the voltage between pin 1 and 2 of the connector (CN10). 3. If the output voltage is 35V, PC board is OK, check motor.
		12	Abnormality of other indoor unit PC board.	All off	Indicated when detected abnormal	Replace PC board.
01	Cable connection/ Thermal fuse Refrigerant system	04	1) Wrong wiring or disconnection of connective cable. 2) Thermal fuse cut off.	All off	Indicated when detected abnormal	1. Check connective cable correct if wiring is wrong. 2. Check thermal fuse and Terminal blocks. 3. If it is OK, check PC board.
03		09	1) Gas shortage. (gas leak) 2) Other refrigerant cycle trouble. 3) Heat exchanger sensor off/break/short. 4) Overload relay or thermostat for compressor break.	All off	Indicated when detected abnormal	1. Check gas quantity. (check gas leakage) 2. If it is OK, check heat exchanger sensor. 3. If heat exchanger sensor is OK. check overload relay and thermostat for compressor. 4. If overload relay and thermostat for compressor are OK, check refrigerant cycle. 5. If refrigerant cycle is OK, check PC board.
		12	Compressor break down.	All off	Indicated when detected abnormal	1. Check compressor. 2. If it is OK, check PC board.

Contents detected by the check codes “04” to “12” are stored in memory of the microcomputer even if the power supply is turned off. Therefore, contents of operations in the past are all displayed.

9-3. Troubleshooting Flowcharts

9-3-1. Power can not be Turned on (No Operation at All)

<Preliminary checks>

- (1) Is the supply voltage normal?
- (2) Is the connection to the AC output OK.?

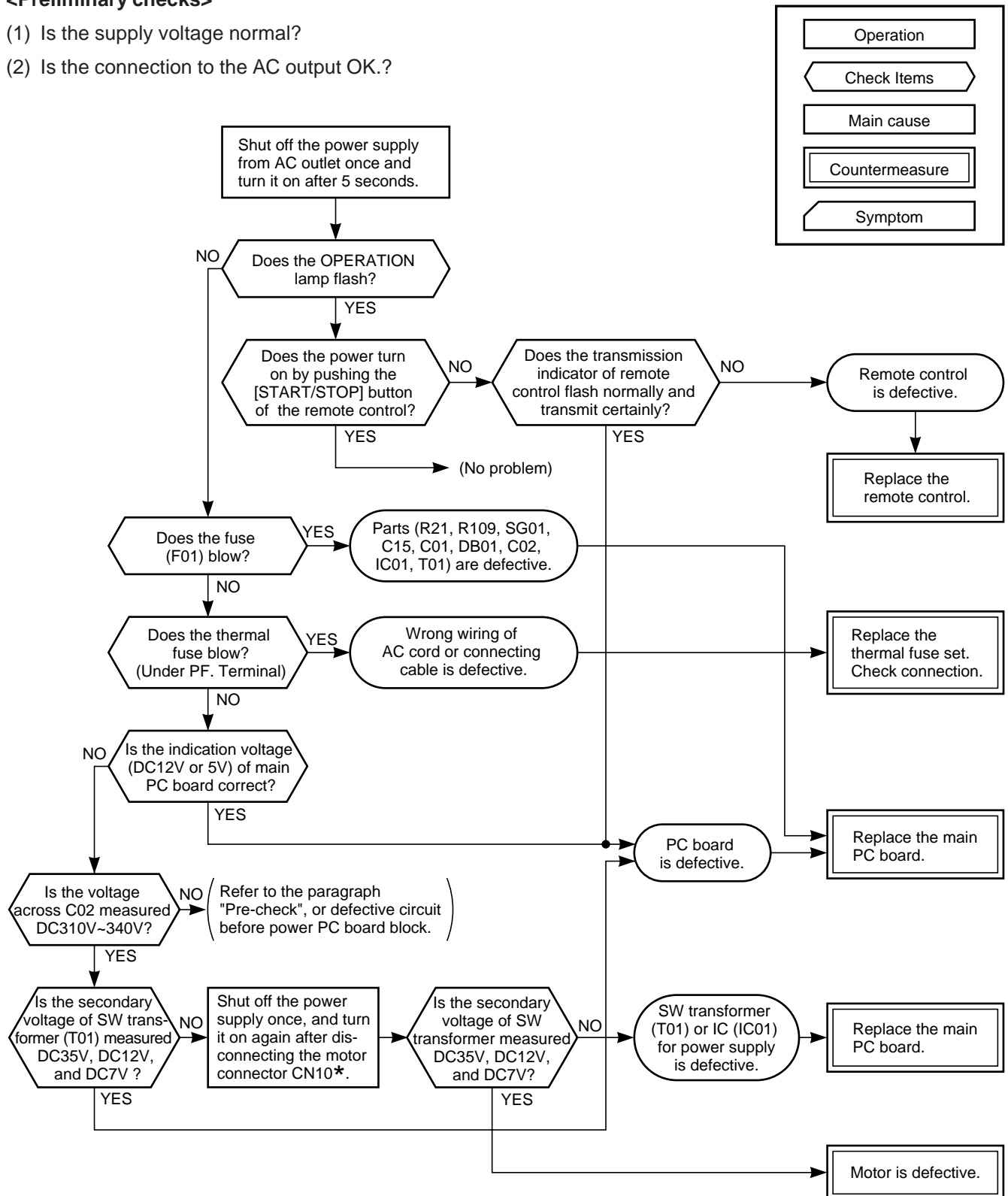

* Be sure to disconnect the motor connector CN10 after shut off the power supply, or it will be a cause of damage of the motor.

9-3-2. Power can not be Turned on after Replacing Indoor PC Board

<Checking Procedure>

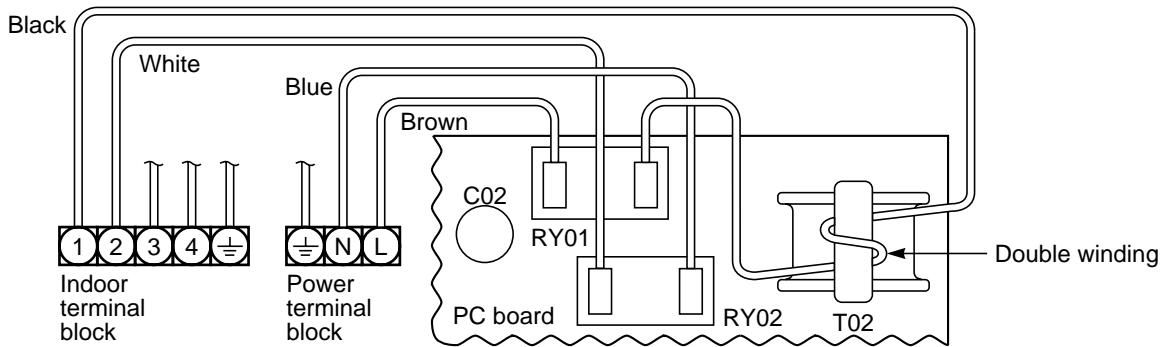
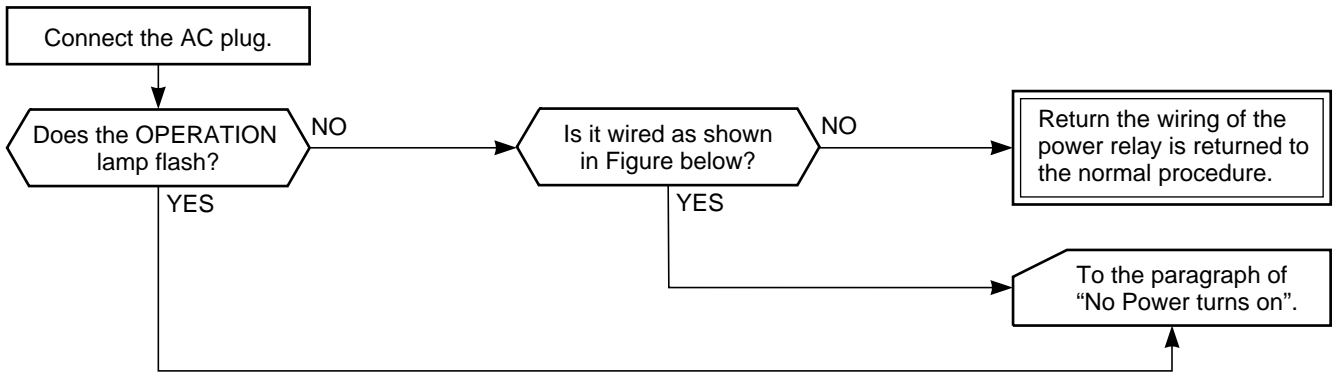

9-3-3. Outdoor Unit does not Operate

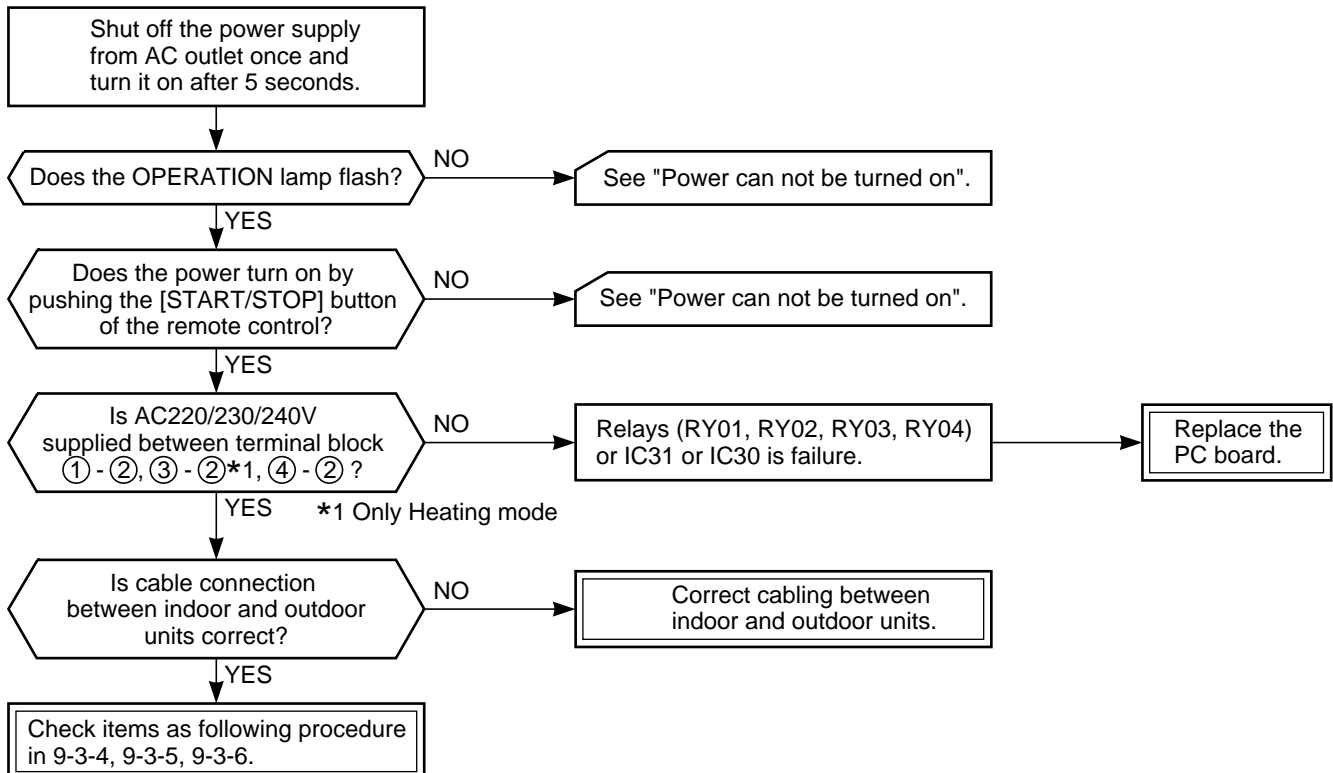

9-3-4. Only Compressor does not Operate

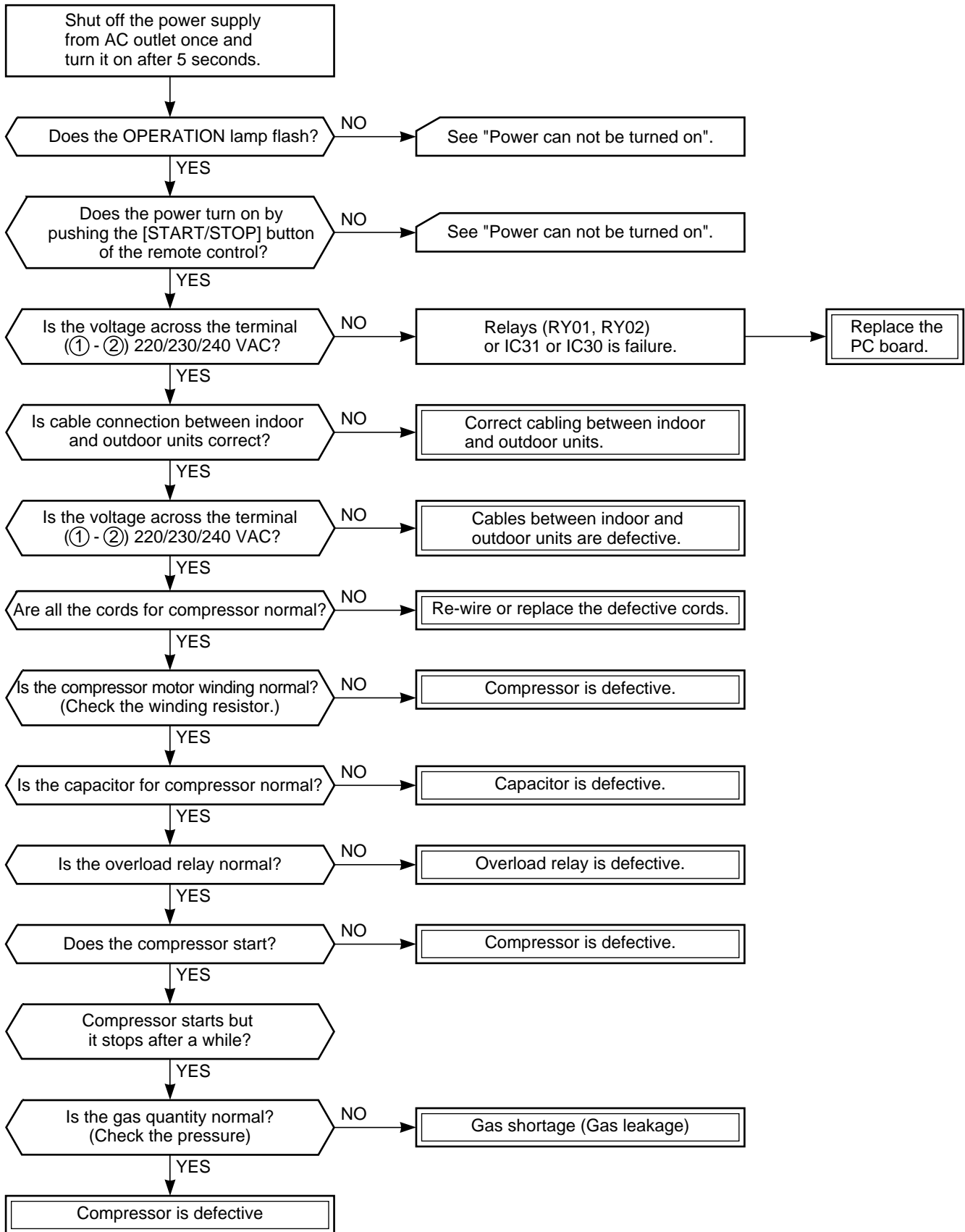

9-3-5. Only Outdoor Fan does not Operate

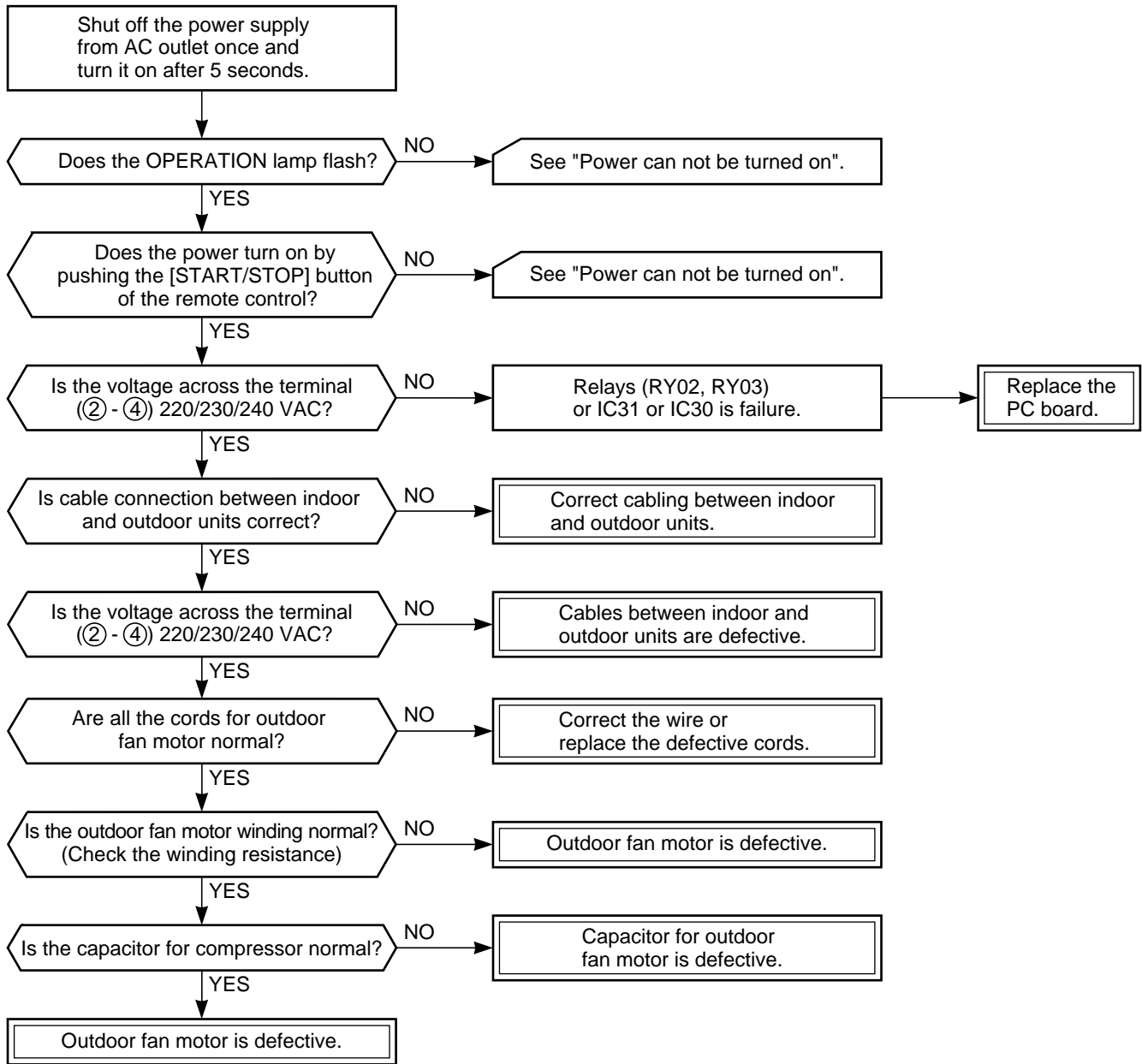

9-3-6. Only 4-Way Valve does not Operate (During Heating Operation)

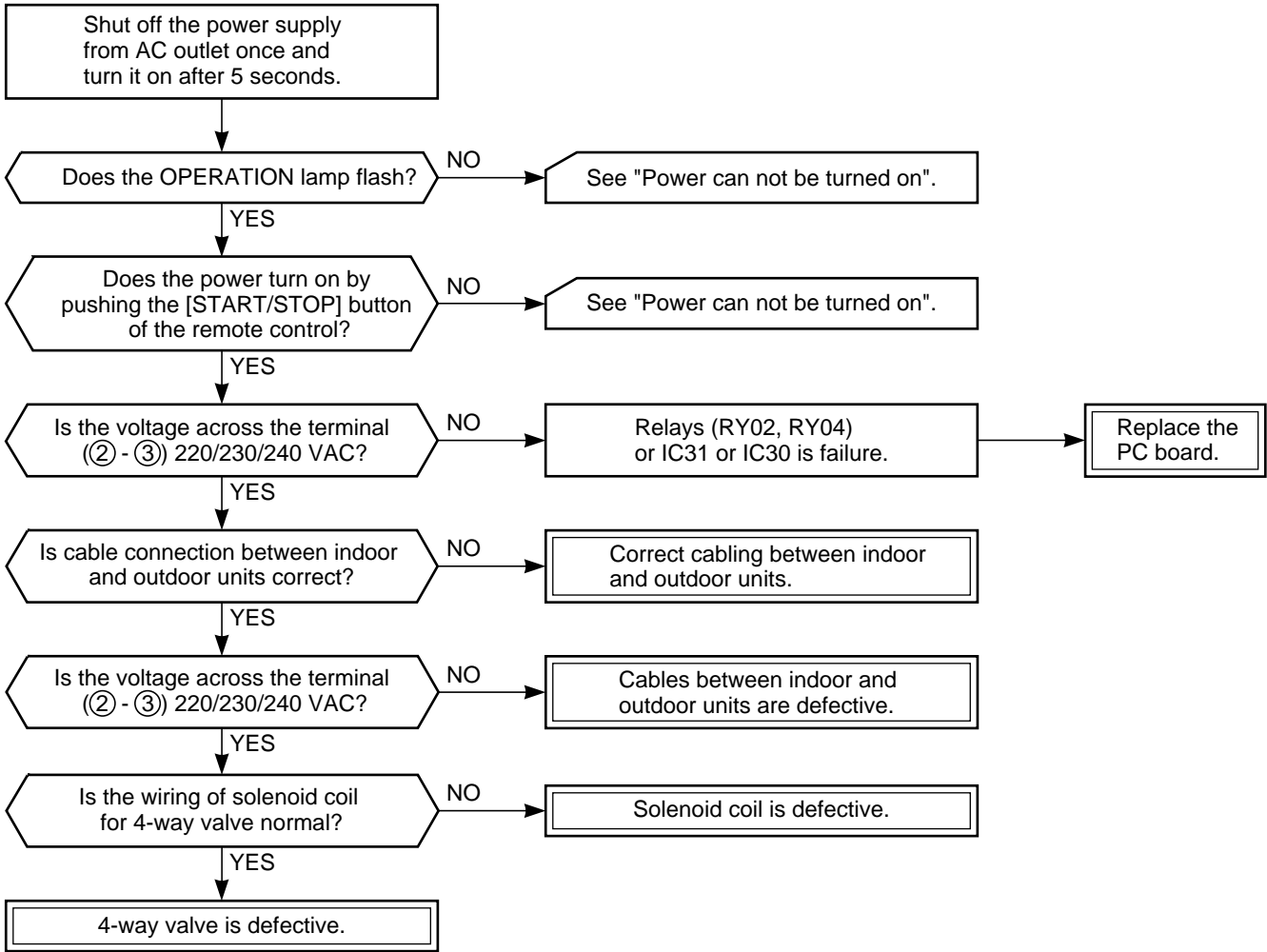

9-3-7. Only the Indoor Fan does not Operate

< Preliminary checks >

Does it neither work in COOL or FAN ONLY operation?

< Check procedure >

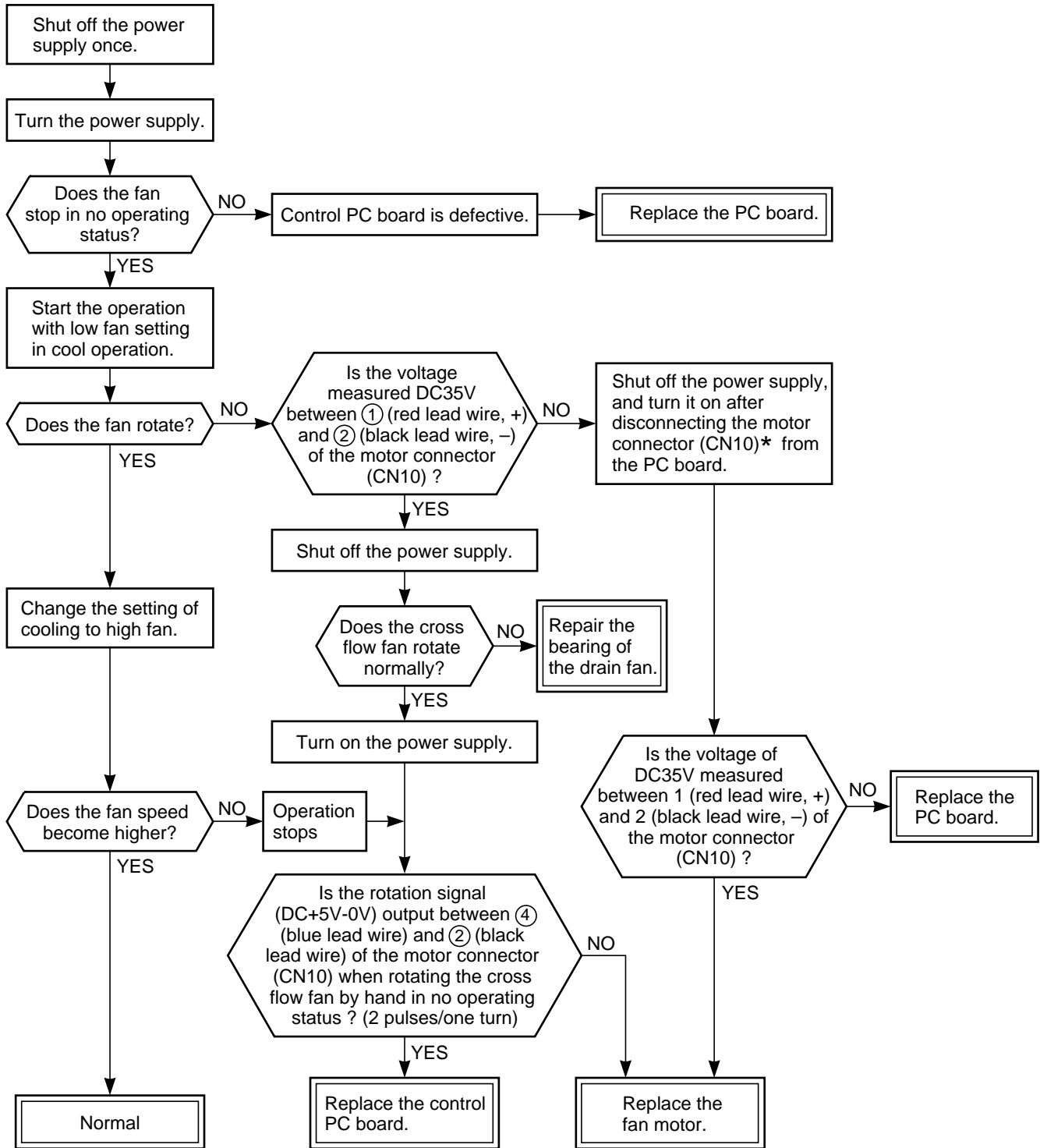

* Be sure to disconnect the motor connector CN10 after shut off the power supply, or it will be a cause of damage of the motor.

9-4. How to Check the Remote Control (Including the Indoor PC Board)

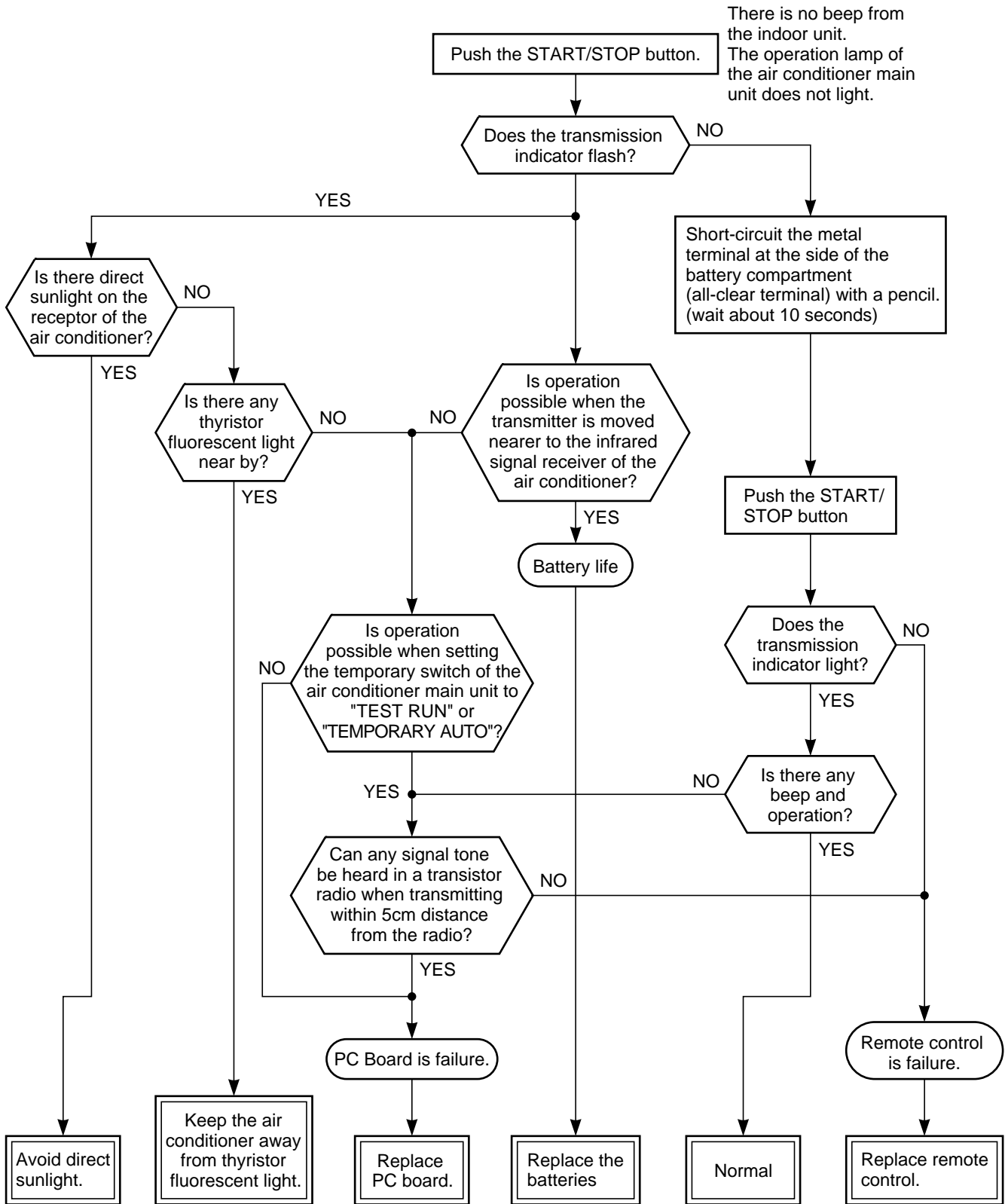

Note: After battery replacement, shortcircuit the metal terminal at the side of the battery compartment (all-clear terminal) with a pencil.

9-4-1. How to Check the PC Board

(1) Operating precautions

- 1) When removing the front panel or the PC board, be sure to shut off the power supply.
- 2) When removing the PC board, hold the edge of the PC board and do not apply force to the parts.
- 3) When connecting or disconnecting the connectors on the PC board, hold the whole housing. Do not pull at the lead wire.

(2) Inspection procedures

- 1) When a PC board is judged to be defective, check for disconnection, burning, or discoloration of the copper foil pattern or this PC board.
- 2) The PC board consists of the following 2 parts
 - a. **Main PC board part:**
Power relay, indoor fan motor drive circuit and control circuit, C.P.U. and peripheral circuits, buzzer drive circuit and buzzer.
 - b. **Infrared rays receive and indication parts:**
Infrared rays receive unit and LED.

(3) Checking procedure

Table 9-4-1

No.	Procedure	Check Point (Symptom)	Causes
1	Shut off the power supply and remove the PC board assembly from the electronic parts base. Remove the connecting cable from the terminal block.	1. Is the fuse blown?	1. * Application of shock voltage. * Overcurrent by short-circuit of the parts.
2	Remove the connector for the motor, and turn the power on. If the OPERATION lamp flashes (0.5 sec. :ON, 0.5 sec. :OFF) when the power turning on, the checking points described as 1-5 of right column are not necessary to perform.	Voltage check 1. Between TP1 and TP2 (220/230/240V AC) 2. Between TP2 and pin 1 of CN04 (220/230/240V AC) 3. Between TP2 and pin 3 of CN04 (220/230/240V AC) 4. Between + and - of C02 (310 ~ 340V DC) 5. Between 35V and GND 6. Between 12V and GND 7. Between 5 V and GND	1. * AC power cord is defective. * Poor contact of the terminal plate. * Miss wiring of the power relay. 2. Fuse is defective. 3. Operation of the thermal fuse. 4. * Capacitor (C01, C15) is defective. * Line filter (L01) is defective. * Resistor (R01) is defective. * Diode (DB01) is defective. 5. IC01, IC02, T01 are defective. 6. IC01, IC02, T01, F03 are defective. 7. IC01, IC02, T01, F02, Q29, IC03 are defective.
3	Make the operation status by pushing once the START/STOP button, except the status of [FAN ONLY], [ON TIMER].	Voltage check 1. Voltage of relay coil. (DC 12V) Between pin 10 of IC31 and GND Between pin 11 of IC31 and GND 2. Between No. 1 and 2 of connecting cable terminal block. (220/230/240V AC)	1. Breaking wire of the relay coil, defective relay driver. (IC31) 2. Poor contact of relay.
4	Start the operation with the system which the time of the restart delay timer is shortened.	1. All indicators light for 3 sec.. 2. Indicators do not indicate normally after approximate 3 sec..	} Defective indicator, or poor housing assembly. (CN13)
5	Make the operation status by pressing once the START/STOP button. 1. The time of the restart delay timer is shortened. 2. Cool operation 3. Air volume [AUTO] 4. Make the setting temperature lower enough than room temperature. 5. Continuous operation.	1. Compressor does not operate. 2. OPERATION lamp flashes.	
6	The status of No. 5 is continued, and make the following condition. 1. Heat operation 2. Make the setting temperature higher enough than room temperature.	1. Compressor does not operate. 2. OPERATION lamp flashes.	1. The temperature of the indoor heat exchanger is abnormally lower. 2. Poor contact of the heat exchanger sensor. (The connector is disconnected.) (CN01) 3. Heat exchanger sensor, main PC board are defective. (Refer to Table 9-4-2 for the judgment of defective resistance values.) 4. Main PC board is defective.
7	The status of No. 5 is continued, and make the following condition. 1. Heat operation 2. Make the setting temperature higher enough than room temperature.	1. Compressor does not operate. 2. OPERATION lamp flashes.	1. The temperature of the heat exchanger is abnormally high. 2. The heat exchanger sensor connector has short-circuit. (CN01) 3. The heat exchanger sensor is defective. (Refer to Table 9-4-2 for the judgment of defective resistance values.) 4. PC board is defective.
7	Turn the power on after connecting the motor connector. Start the operation with the following condition. 1. Operation [Cooling] 2. Airflow [High fan] 3. Continuous operation	1. The voltage of DC 35V is not measured between the red and black of the motor terminals. 2. Motor does not rotate. (The key operation is accepted.) 3. The motor rotates, but it vibrates too much.	1. Indoor fan motor is defective. (Protecting operation on the PC board.) 2. Poor contact of the motor connector. 3. PC board is defective.

9-4-2. PC Board Layout

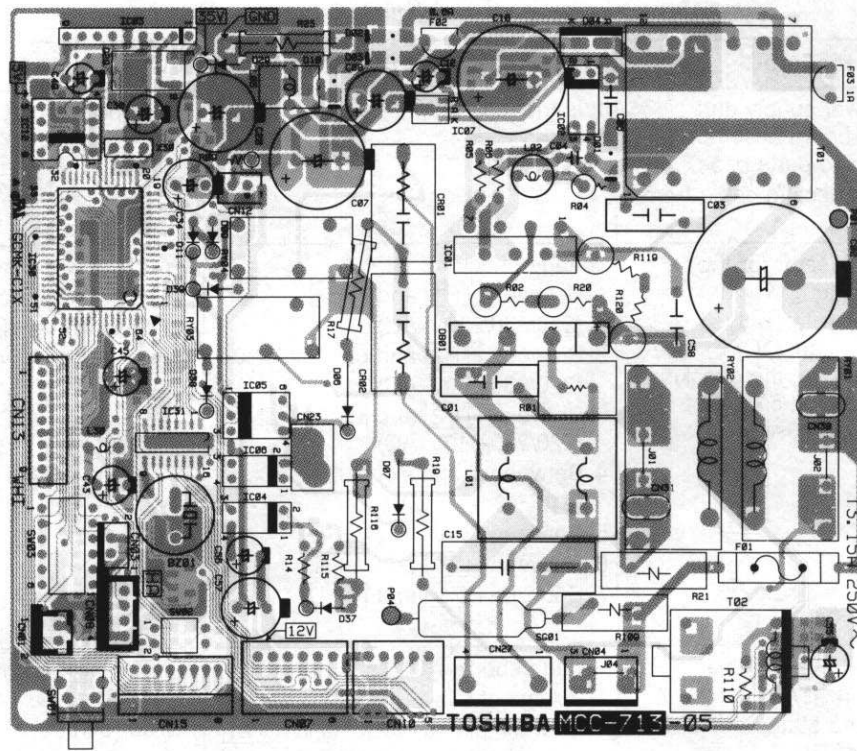

Top View

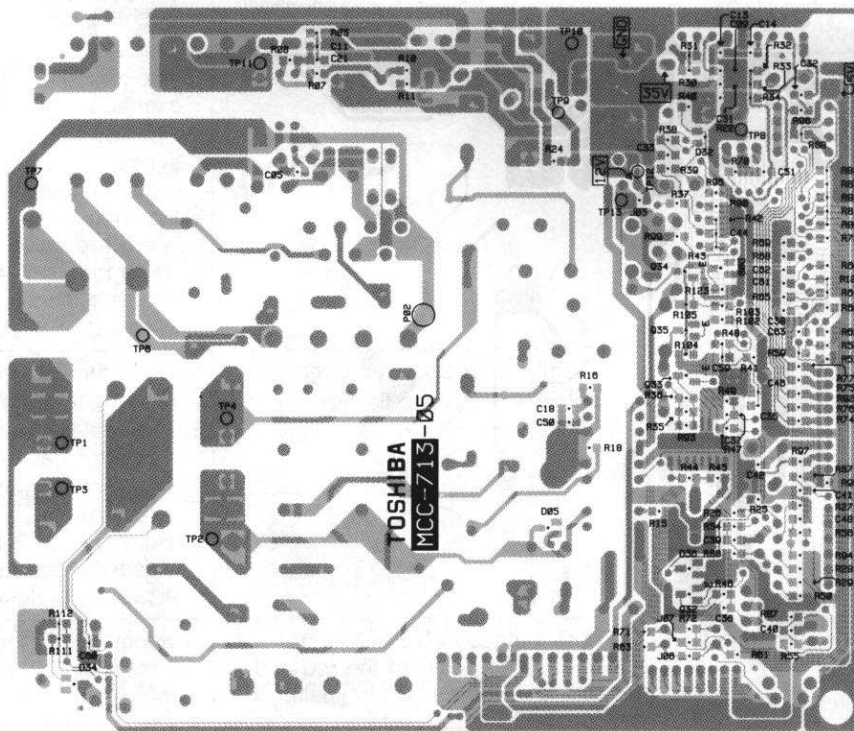

Bottom View

Table 9-4-2 Approximate value of the sensor (thermistor) resistance (TA, TC)

(= kΩ)

Sensor \ Temperature	0°C	10°C	20°C	25°C	30°C
Themo Sensor	35.8	20.7	12.6	10.0	7.92

9-4-3. How to Reduce the Operation Time of the Anti-Restart Timer

- Attach the diode (1S1555 or equivalent) to the rivet inside the unit through holes on the rear of the wireless remote control unit.
- Push the START/STOP button to start operation with the diode attached.

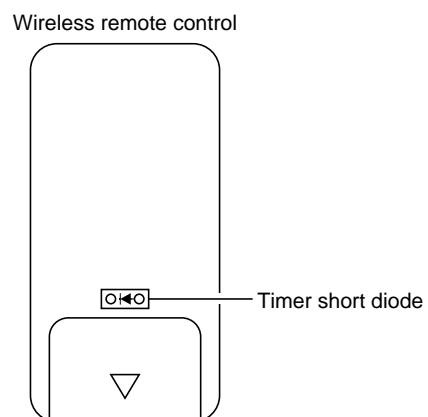
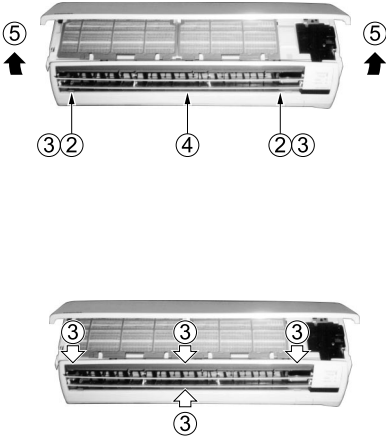
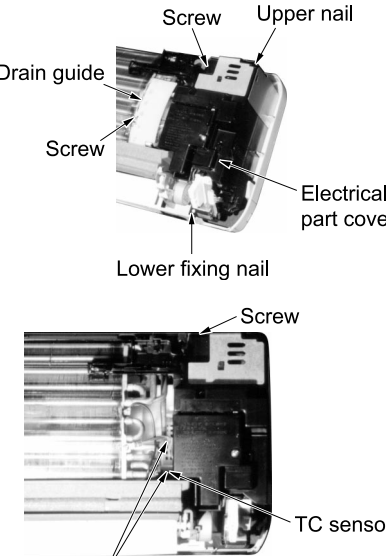
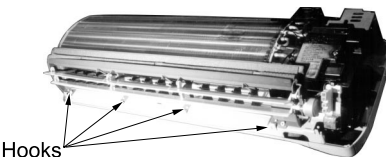
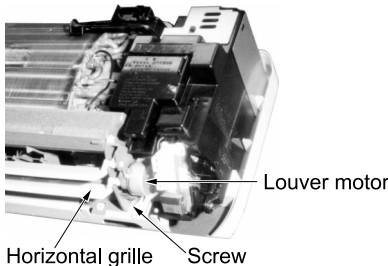
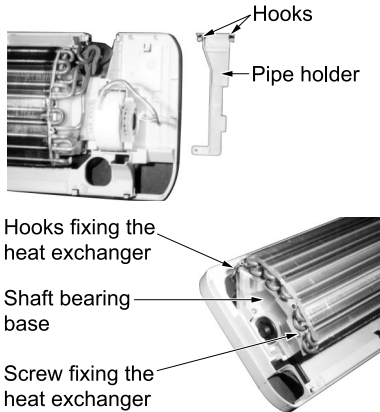
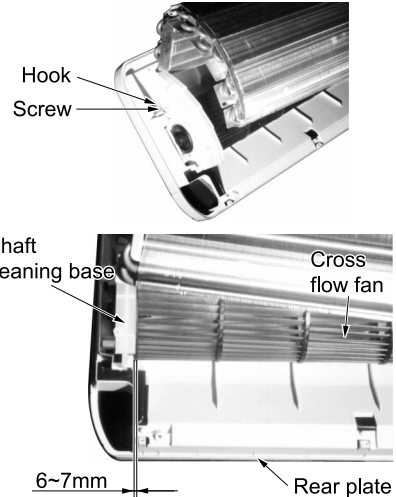



Fig. 9-4-1

10. PART REPLACEMENT

10-1. Indoor Unit (RAS-10SKH-E, RAS-10SKHX)



No.	Part name	Procedure	Remarks
①	Front panel	<ol style="list-style-type: none"> 1) After stopping the operation of the air conditioner, be sure to turn off the circuit breaker or disconnect the power plug from the AC wall socket. 2) Open the screw caps and remove the two screws fixing the front panel. 3) Close the screw caps as they were. 4) Open the horizontal louver right below by your finger. 5) Open the lower side of front panel until it touches the horizontal louver, and remove it from the indoor unit by turning it. <p style="text-align: center;"><To assemble the front panel></p> <ol style="list-style-type: none"> 1) Fix the two screws to secure the front panel. 2) Close the screw caps as they were. 3) Press four places where are the center, right end, left end and lower portions of the air outlet. 4) Check the gap between the front panel and the main unit. <p>If cooling or drying operation is performed without pressing the center of the air outlet, the surface of the front panel may be covered with frost and have a waterdrop.</p>	
②	Electrical part assembly	<ol style="list-style-type: none"> 1) Perform the process ① above. 2) Remove the screw securing the shield metal plate. 3) Remove the electrical part cover by pressing the nail located on upper portion of the electrical part cover. 4) Remove the drain guide. 5) Remove the screw securing to the end plate of the heat exchanger. 6) Remove the connector (5p) for the fan motor and the connector (6p) for the louver motor from the microcomputer assembly. 7) After unhooking the electrical part base by pressing the fixing nail located on its lower portion, draw the electrical part base out toward you to remove it from the main unit. 8) Pull the TC sensor out from the holder of the heat exchanger. 9) Dress the connecting cable securely as shown in the right illustration. (Improper dressing will cause water leakage.) 	 <p>When assembling dress the connecting cable in loop and put it into the drain-pan.</p>
③	Drain-pan assembly	<ol style="list-style-type: none"> 1) Perform the process ② above. 2) Remove the drain-pan by pressing the four hooks downwards. (Keep it with the drain hose.) 	

No.	Part name	Procedure	Remarks
④	Horizontal grille Note: The horizontal grille can not be removed without removing the louver motor.	<ol style="list-style-type: none"> 1) Perform the process ②. 2) Remove the screw fixing the louver motor, and remove the louver motor. 3) Remove the shaft of the horizontal grille from the drain-pan. 	
⑤	Heat exchanger	<ol style="list-style-type: none"> 1) Perform the process ③. 2) Remove the pipe holder from the rear side of main unit by removing the screw. 3) Unhook the hooks fixing the left side of the heat exchanger and remove the screw fixing it, then remove the right side of the end plate from the rib fixing the main unit by sliding the heat exchanger slightly to the right side. 	
⑥	Cross flow fan	<ol style="list-style-type: none"> 1) Perform the process ③. 2) Loosen the set screw of the cross flow fan. 3) Remove the screw fixing the shaft bearing base. 4) Lift slightly up the left side of the heat exchanger, and pull the shaft bearing base out left downwards. <p>When assembling it, fix it with the set screw on the position where the gap between the rear plate surface and the left end surface of the cross flow fan is 6 ~ 7mm.</p>	
⑦	Shaft bearing	<ol style="list-style-type: none"> 1) Perform the process ⑥ above. 2) Remove the shaft bearing from the shaft bearing base. <p><Caution for assembling></p> <ul style="list-style-type: none"> • If a part of the shaft bearing is protruded from the housing, assemble it after pushing its portion into the correct position in the housing. 	
⑧	Fan motor	<ol style="list-style-type: none"> 1) Perform the process ⑤ above. 2) Perform the process ⑥-2) above. 3) Remove the left and right motor bands. 4) Remove the fan motor after pulling the cross flow fan out sliding it left and right. 	 <p>Mount the fan motor as shown in figure below when assembling.</p> <p>Put the end of lead wire at the portion between two ribs.</p>

10-2. Microcomputer (RAS-10SKH-E, RAS-10SKHX)

No.	Part name	Procedure	Remarks
①	Common procedure	1) Turn the power supply off to stop the operation of air-conditioner, and disconnect the power cord from the AC supply. 2) Remove the front panel. <ul style="list-style-type: none"> • Remove the two fixing screws. ($\phi 4 \times 14 \text{ l}$) 3) Remove the electrical part base.	Replace the thermal fuse, terminal block, power cord, microcomputer ass'y and the power supply PC board ass'y.
②	Thermal fuse replacement	1) Perform the process ① above. 2) Remove terminal cover (Up), (Down). 3) Disconnect the terminal blocks connected with the connecting cable, and the power cord from base E-parts by removing the screws. 4) Remove the thermal fuse (77°C) from base E-parts.	

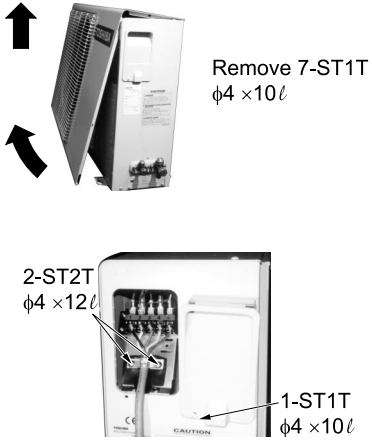
10-3. Outdoor Unit (RAS-10SAH-E, RAS-10SAHX)

No.	Part name	Procedure	Remarks
①	Common procedure	<ol style="list-style-type: none"> 1) Stop the operation of air-conditioner, and disconnect the power cord from the AC supply. 2) Remove E-parts cover. (1- ST1T $\phi 4 \times 10 \text{ l}$) 3) Remove the cord clamp (2- ST2T $\phi 4 \times 12 \text{ l}$) and remove the connecting cable. 4) Remove the front cabinet. (7- ST1T $\phi 4 \times 10 \text{ l}$ with nylon washer) <ul style="list-style-type: none"> • Pull the front lower portion toward you, and remove it pulling out upward. 	 <p>Remove 7-ST1T $\phi 4 \times 10 \text{ l}$</p> <p>2-ST2T $\phi 4 \times 12 \text{ l}$</p> <p>1-ST1T $\phi 4 \times 10 \text{ l}$</p>
②	Capacitor for compressor	<ol style="list-style-type: none"> 1) Remove the fixing screw securing the capacitor band. (1- ST2T $\phi 4 \times 8 \text{ l}$) 2) Remove the cable connected to the terminal. 	Refer to [Electrical parts list and location] in page 61.
③	Capacitor for fan motor	<ol style="list-style-type: none"> 1) Remove the fixing screw. (1- ST2T $\phi 4 \times 8 \text{ l}$) 2) Remove the cable connected to the terminal. 	Same as above.
④	Overload relay	<ol style="list-style-type: none"> 1) Perform the process ① above. 2) Remove terminal cover of compressor. 3) Remove OL holder and pull OL relay up. 4) Remove Fustons of leads. 	 <p>Compressor</p>

12. EXPLODED VIEWS AND PARTS LIST

12-1. Indoor Unit (1)

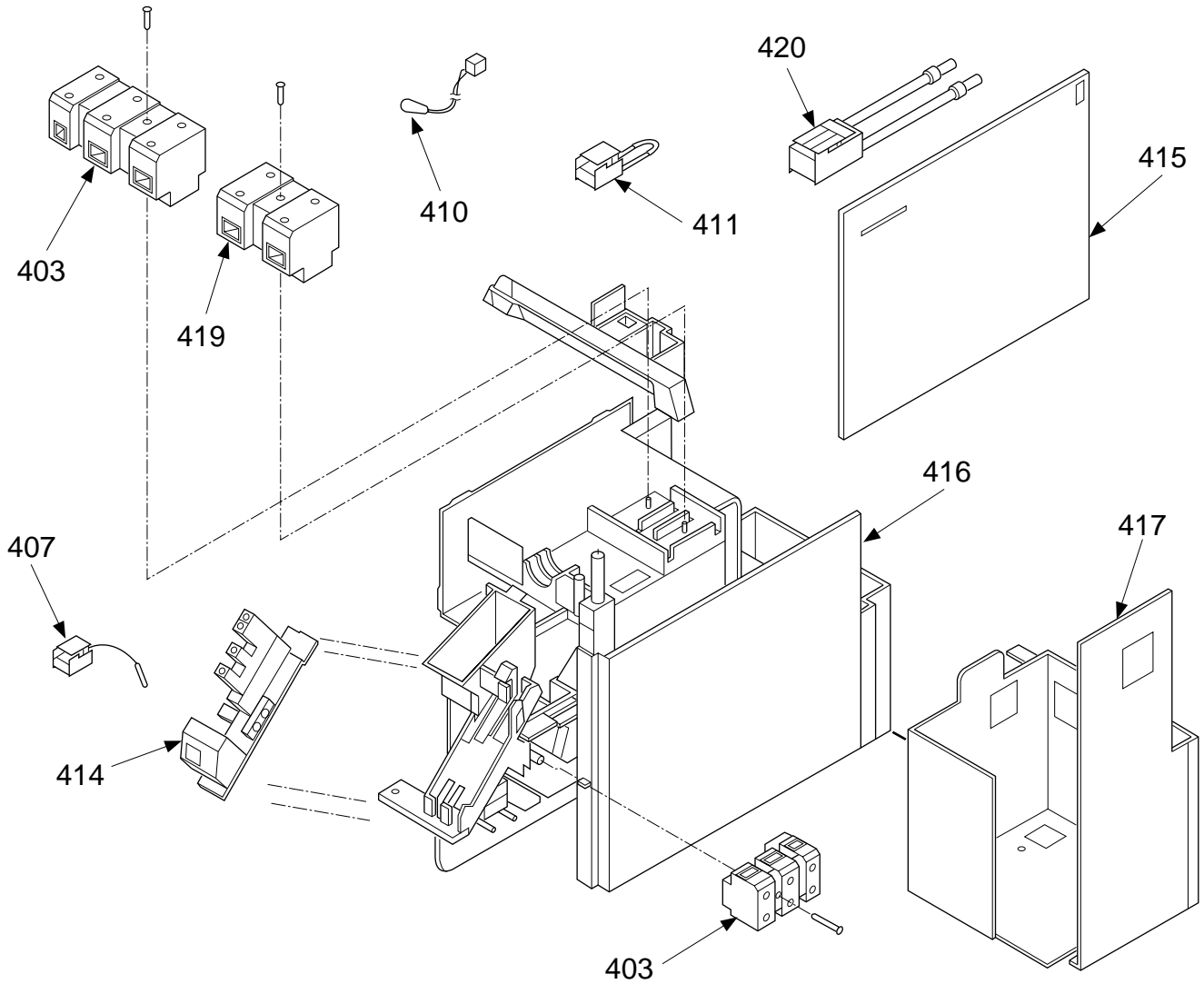

Location No.	Part No.	Description
403	43T60002	Base, Terminal 3P, AC 300V, 20A
407	43T69004	Sensor, Heat Exchanger 10kΩ, 25°C
410	43T69005	Sensor, Thermostat 10kΩ, 25°C
411	43T60004	Fuse, Temperature 77°C
414	43T69007	PC Board, WRS-LED MCC-635

Location No.	Part No.	Description
415	43T69008	PC Board A'ssy MCC-713
416	43T61001	Base, E-Parts ABS, Black, UL94-5V
417	43T62006	Base, Shield SGCC-Z08-LUB
419	43T60001	Base, Terminal 2P, AC 300V, 20A
420	43T60005	Housing 4P

Indoor Unit (2)

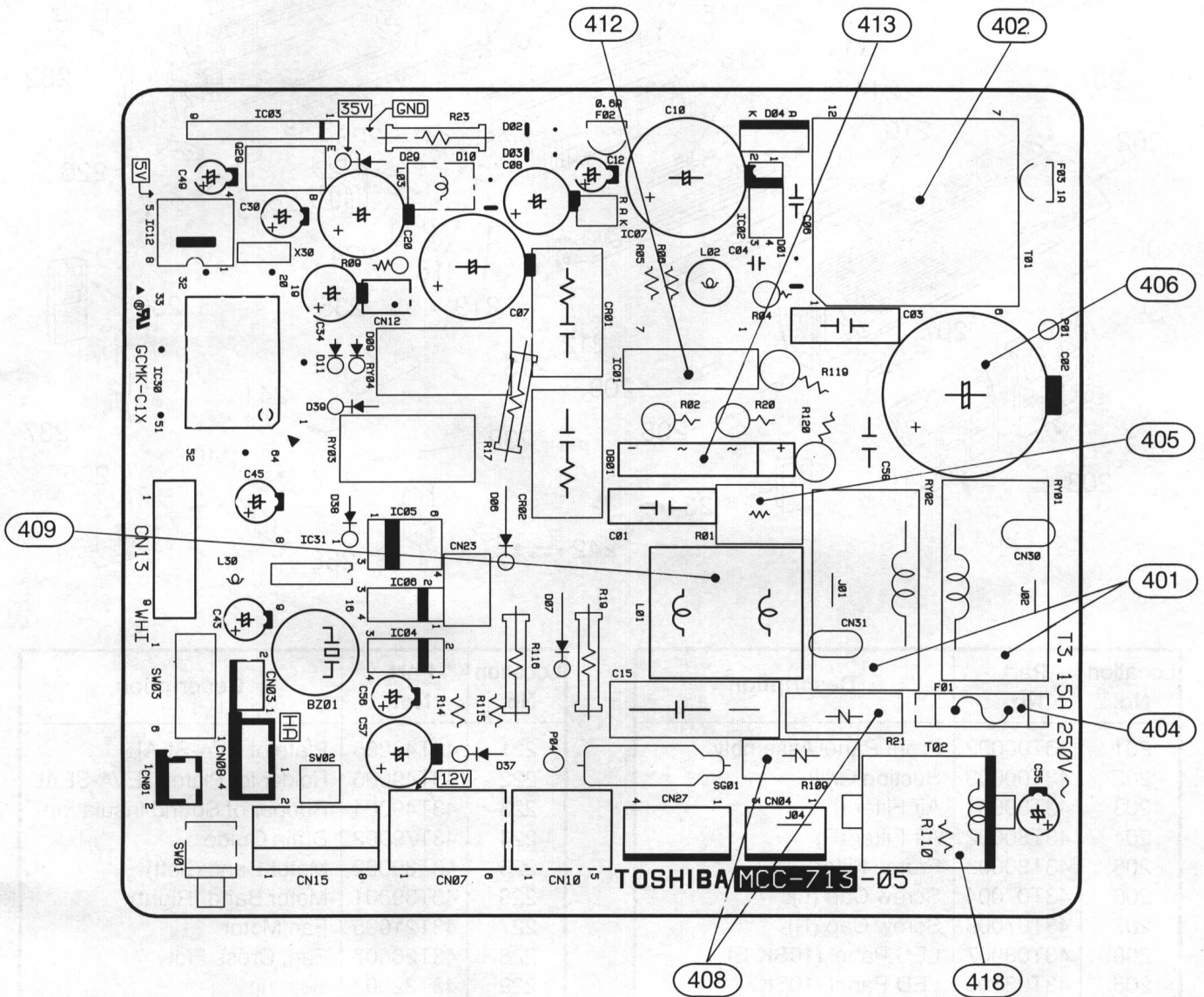

Location No.	Part No.	Description
401	43T69003	Relay, Power DI1U, 20A, AC 250V
402	43T58002	Transformer, Switching SWT-34
404	43T60003	Fuse 3.15A, AC 250V
405	43T32001	Resistor 5.6Ω, 5W
406	43T33001	Capacitor, Electrolytic 100MFD, 450V, AUF

Location No.	Part No.	Description
408	43T55004	Varistor 560V
409	43T34001	Filter, Line 0.6A
412	43T30001	IC, Switching MA 2830P-FJ
413	43T31001	Diode, Rectifier RBV-406, 600V
418	43T58001	Transformer, Current CT422920S-01

Indoor Unit (3)

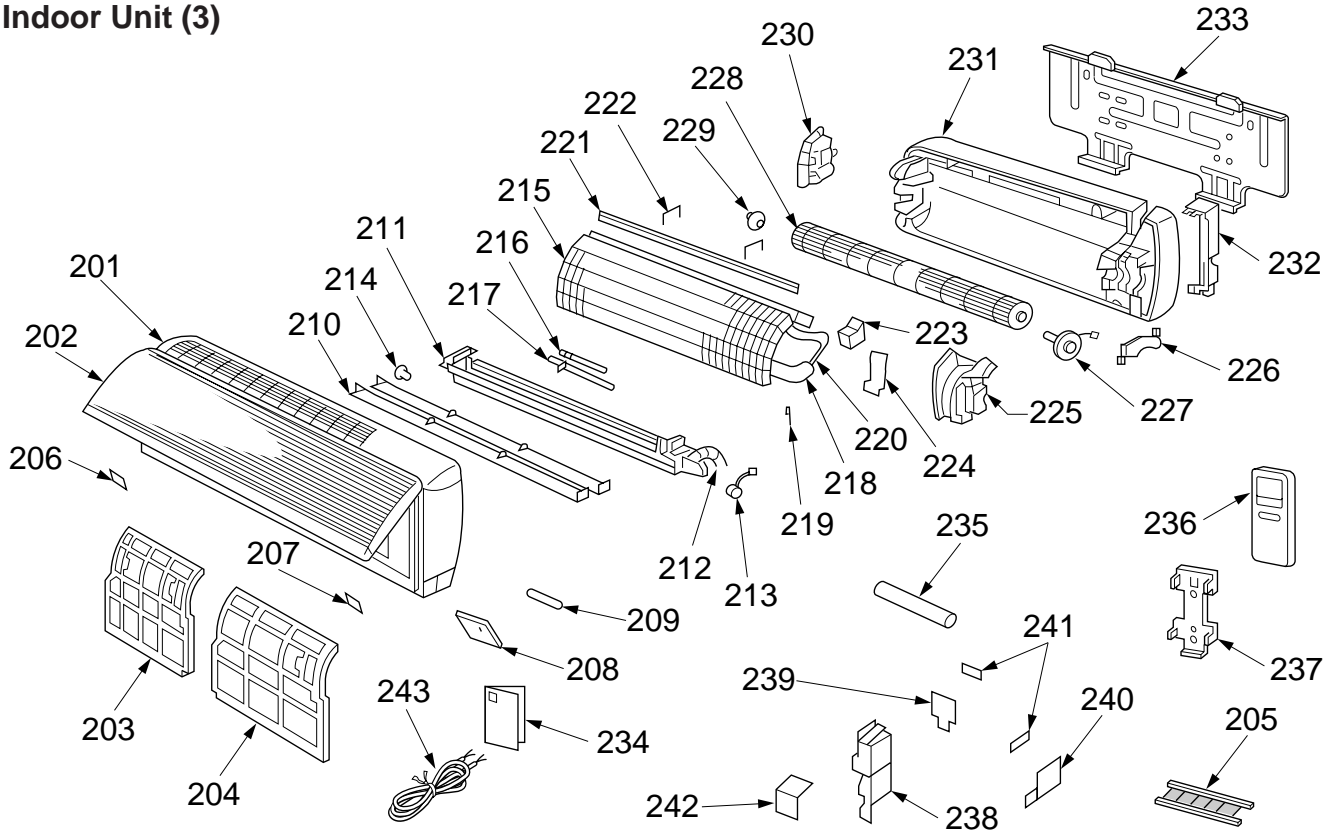

Location No.	Part No.	Description
201	43T00002	Front Panel Assembly
202	43T00003	Suction Grille
203	43T80001	Air Filter (L)
204	43T80002	Air Filter (R)
205	43T80003	Frame Filter
206	43T07004	Screw Cap (L)
207	43T07003	Screw Cap (R)
208	43T08001	LED Panel (10SKH-E)
208	43T08006	LED Panel (10SKHX)
209	43T19004	Accepted Signal Filter
210	43T09003	Horizontal Louver Assembly for Service
211	43T09004	Louver Assembly
212	43T70001	Drain Hose Assembly
213	43T21003	Motor Stepping
214	43T07001	Bushing
215	43T44002	Refrigeration Cycle Assembly
216	43T47006	Pipe, Delivery
217	43T47005	Pipe, Suction
218	43T49007	Pipe, Shield
219	43T19003	Holder, Sensor
220	43T49003	Spring
221	43T49005	Plate of EVA-SEAL

Location No.	Part No.	Description
222	43T49006	Holder for Plate of EVA-SEAL
223	43T49004	Rubber of Sound Insulation
224	43T79002	Drain Guide
225	43T39002	Motor Band (Left)
226	43T39001	Motor Band (Right)
227	43T21005	Fan Motor
228	43T20007	Fan, Cross Flow
229	43T22002	Bearing
230	43T39003	Base, Bearing
231	43T03001	Rear Plate
232	43T07002	Pipe Holder
233	43T82001	Installation Plate
234	43T85001	Owner's Manual (10SKH-E)
234	43T85003	Owner's Manual (10SKHX)
235	43T11001	Pipe Shield
236	43T69002	Remote Control
237	43T63002	Holder, Remote Control
238	43T62001	Cover, E-Parts
239	43T62002	Terminal Cover (Up)
240	43T62005	Terminal Cover (Down)
241	43T62003	Cord Clamp
242	43T62004	Shield Cover
243	43T60007	Cord Power

12-2. Outdoor Unit

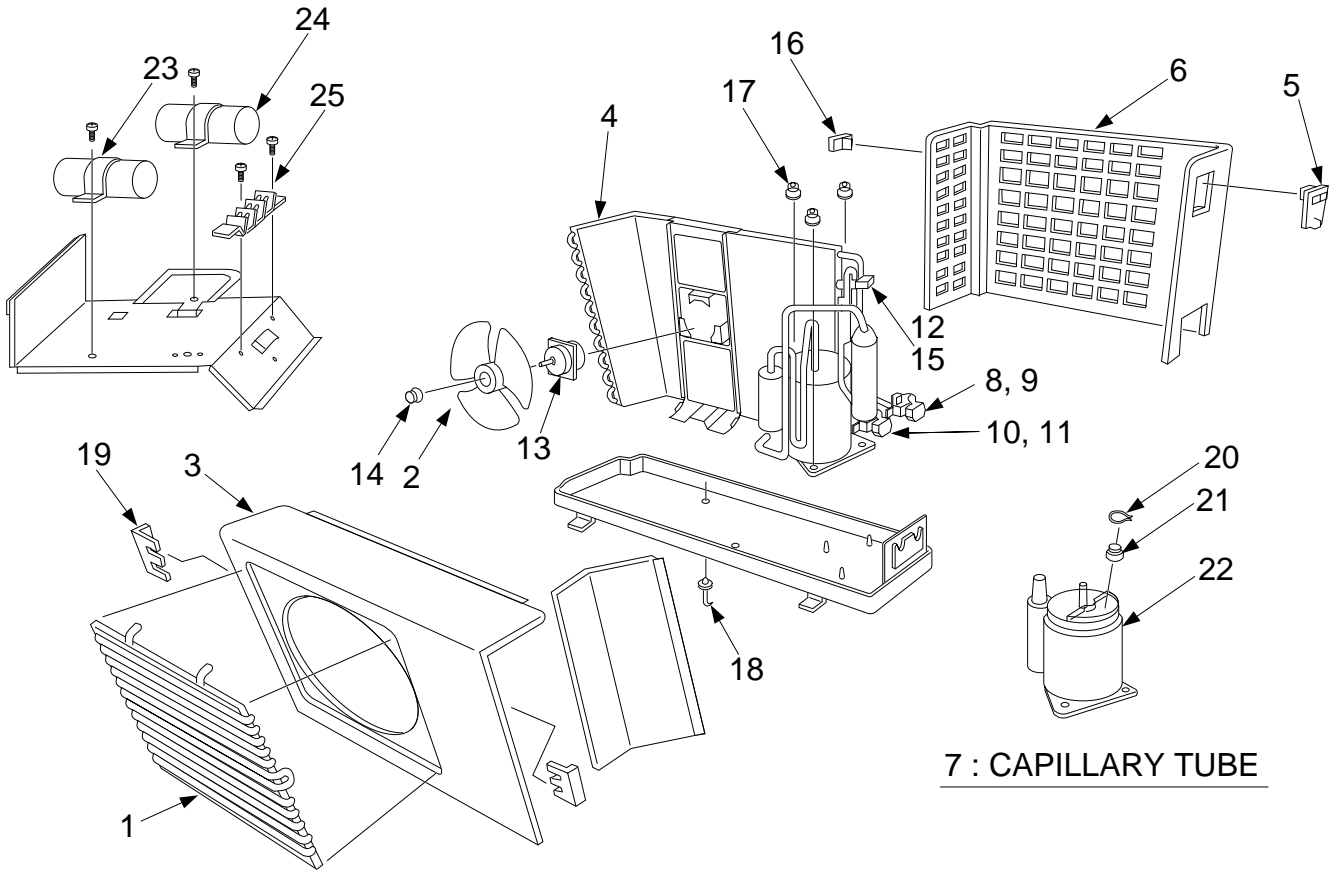

Location No.	Part No.	Description
1	43T19001	Guard Fan
2	43T20001	Fan, Propeller
3	43005037	Front Cabinet
4	43T43001	Condenser
5	43062194	Cover, E-Parts
6	43005038	Back Cabinet
7	43T47004	Capillary-Tube 1.7 DIA
8	43T46001	Packed Valve, 9.52
9	43T47002	Bonnet, 9.52 DIA
10	43T46002	Packed Valve, 6.35
11	43T47003	Bonnet, 6.35 DIA
12	43T46003	4-Way-Valve, VH7100D
13	43T21001	Fan-Motor UE6-21SJ5P

Location No.	Part No.	Description
14	43T47001	Flange, Nut
15	43046255	Solenoid Coil
16	43T19005	Handle
17	43T49001	Rubber-Cushion
18	43T79001	Nipple, Drain
19	43T19002	Stopper, Guard
20	43T63001	Holder, OL-Relay
21	43054403	Relay, Over-Load J-MRA 99269-9200
22	43T41400	Compressor, PH120T1-4C
23	43055483	MF Capacitor 25 μ F 400V
24	43T55001	MF Capacitor 1.5 μ F, 500V
25	43060049	Terminal Block, 5P

TOSHIBA CORPORATION

1-1, SHIBAURA 1-CHOME, MINATO-KU, TOKYO, 105-01, JAPAN