

---

**User's  
Manual**

**YTA** SERIES

**YTA Series  
Temperature Transmitters  
(Hardware)**

[Style: S3]

IM 01C50B01-01E

---

**vigilantplant.**<sup>®</sup>

# CONTENTS

---

|   |            |
|---|------------|
| <b>1. PREFACE .....</b>   | <b>1-1</b> |
| Notes on the User's Manual .....                                | 1-1        |
| Notes on Safety and Modifications .....                         | 1-1        |
| For Safe Use of Product .....                                   | 1-1        |
| Warranty .....  | 1-2        |
| Trademarks .....  | 1-2        |
| ATEX Documentation .....  | 1-3        |
| <b>2. NOTES ON HANDLING .....</b>                               | <b>2-1</b> |
| 2.1 Nameplate .....   | 2-1        |
| 2.2 Transport .....   | 2-1        |
| 2.3 Storage .....   | 2-1        |
| 2.4 Choosing the Installation Location .....                    | 2-1        |
| 2.5 Use of a Transceiver .....                                  | 2-2        |
| 2.6 Insulation Resistance Test and Withstand Voltage Test ..... | 2-2        |
| 2.6.1 Insulation resistance test procedure .....                | 2-2        |
| 2.6.2 Withstand voltage test procedure .....                    | 2-3        |
| 2.7 Installation of Explosion Protected Type Transmitters ..... | 2-3        |
| 2.7.1 CSA Certification .....                                   | 2-3        |
| 2.7.2 CENELEC ATEX (KEMA) Certification .....                   | 2-5        |
| 2.7.3 FM Certification .....                                    | 2-8        |
| 2.7.4 TIIS Certification .....                                  | 2-9        |
| 2.7.5 SAA Certification .....                                   | 2-10       |
| 2.7.6 IECEx Certification .....                                 | 2-11       |
| 2.8 EMC Conformity Standards .....                              | 2-11       |
| 2.9 Low Voltage Directive .....                                 | 2-11       |
| <b>3. PART NAMES AND FUNCTIONS .....</b>                        | <b>3-1</b> |
| 3.1 Part Names .....  | 3-1        |
| 3.2 Setting the Hardware Error Burnout Change-over Switch ..... | 3-2        |
| 3.3 Built-in Indicator Display Function .....                   | 3-2        |
| <b>4. INSTALLATION .....</b>                                    | <b>4-1</b> |
| <b>5. WIRING .....</b>  | <b>5-1</b> |
| 5.1 Notes on Wiring .....                                       | 5-1        |
| 5.2 Loop Construction .....                                     | 5-1        |
| 5.3 Cable Selection .....                                       | 5-2        |
| 5.3.1 Input signal Cable Selection .....                        | 5-2        |
| 5.3.2 Output Signal Cable Selection .....                       | 5-2        |
| 5.4 Cable and Terminal Connections .....                        | 5-2        |
| 5.4.1 Input Terminal Connections .....                          | 5-2        |
| 5.4.2 Output Terminal Connection .....                          | 5-3        |
| 5.5 Wiring Cautions .....                                       | 5-4        |
| 5.6 Grounding .....   | 5-5        |

|  |                          |
|--|--------------------------|
| <b>6. MAINTENANCE .....</b>  | <b>6-1</b>               |
| 6.1 General .....  | 6-1                      |
| 6.2 Calibration .....  | 6-1                      |
| 6.2.1 Selection of Equipment for Calibration .....                                   | 6-1                      |
| 6.2.2 Calibration Procedure .....  | 6-1                      |
| 6.3 Disassembly and Assembly .....   | 6-2                      |
| 6.3.1 Replacement of Built-in Indicator .....  | 6-3                      |
| 6.3.2 Replacement of CPU Assembly .....  | 6-3                      |
| 6.4 Troubleshooting .....  | 6-4                      |
| 6.4.1 Basic Troubleshooting Flow .....   | 6-4                      |
| 6.4.2 Example of Troubleshooting Flow .....  | 6-4                      |
| 6.5 Integral Indicator and Error Display .....                                       | 6-6                      |
| <b>7. GENERAL SPECIFICATIONS .....</b>   | <b>7-1</b>               |
| 7.1 Standard Specifications .....  | 7-1                      |
| 7.2 Model and Suffix Codes .....   | 7-5                      |
| 7.3 Optional Specifications .....  | 7-5                      |
| 7.4 Dimensions .....   | 7-8                      |
| <b>INSTALLATION AND OPERATING PRECAUTIONS FOR JIS FLAMEPROOF<br/>EQUIPMENT .....</b> | <b>EX-B03E</b>           |
| <b>Customer Maintenance Parts List .....</b>   | <b>CMPL 01C50B01-02E</b> |
| <b>REVISION RECORD</b>   |                          |

# 1. PREFACE

---

The YTA temperature transmitter is fully factory-tested according to the specifications indicated on the order.

In order for the YTA temperature transmitter to be fully functional and to operate in an efficient manner, the manual must be carefully read to become familiar with the functions, operation, and handling of the YTA.

This manual gives instructions on handling, wiring and maintenance of YTA110, YTA310 and YTA320 temperature transmitters. Changing the parameter settings requires a terminal dedicated to the HART protocol or the BRAIN protocol. For details on how to set the parameters of these transmitters, refer to the “BRAIN Protocol” IM 01C50T03-01E or “HART Protocol” IM 01C50T01-01E.

For FOUNDATION Fieldbus communication type, please refer to IM 01C50T02-01E in addition to this manual.

## ■ Notes on the User’s Manual

- This manual should be delivered to the end user.
- The information contained in this manual is subject to change without prior notice.
- The information contained in this manual, in whole or part, shall not be transcribed or copied without notice.
- In no case does this manual guarantee the merchant ability of the transmitter or its adaptability to a specific client need.
- Should any doubt or error be found in this manual, submit inquiries to your local dealer.
- No special specifications are contained in this manual.
- Changes to specifications, structure, and components used may not lead to the revision of this manual unless such changes affect the function and performance of the transmitter.

## ■ Notes on Safety and Modifications

- Before handling the YTA, it is absolutely imperative that users of this equipment read and observe the safety instructions mentioned in each section of the manual in order to ensure the protection and safety of operators, the YTA itself and the system containing the transmitter. We are not liable for any accidents arising out of handling that does not adhere to the guidelines established in the safety instructions.

- No maintenance should be performed on explosion-proof type temperature transmitters while the equipment is energized. If maintenance is required with the cover open, always first use a gas detector to check that no explosive gases are present.
- If the user attempts to repair or modify an explosionproof type transmitter and is unable to restore it to its original condition, damage to the explosionproof features result, leading to dangerous conditions. Contact your authorized Yokogawa Electric Corporation representative for repairs or modifications of an explosionproof type transmitter.

## ■ For Safe Use of Product

Please give your attention to the followings.

### (a) Installation

- The instrument must be installed by an expert engineer or a skilled personnel. The procedures described about INSTALLATION are not permitted for operators.
- In case of high process temperature, care should be taken not to burn yourself because the surface of the case reaches a high temperature.
- All installation shall comply with local installation requirement and local electrical code.

### (b) Wiring

- The instrument must be installed by an expert engineer or a skilled personnel. The procedures described about WIRING are not permitted for operators.
- Please confirm that voltages between the power supply and the instrument before connecting the power cables and that the cables are not powered before connecting.

### (c) Maintenance

- Please do not carry out except being written to a maintenance descriptions. When these procedures are needed, please contact nearest YOKOGAWA office.
- Care should be taken to prevent the build up of drift, dust or other material on the display glass and name plate. In case of its maintenance, soft and dry cloth is used.

**(d) Modification**

- Yokogawa will not be liable for malfunctions or damage resulting from any modification made to this instrument by the customer.

**● Symbols used in this manual**

The YTA temperature transmitter and this manual use the following safety related symbols and signals.

**WARNING**

---

Contains precautions to protect against the chance of explosion or electric shock which, if not observed, could lead to death or serious injury.

---

**CAUTION**

---

Contains precautions to protect against danger, which, if not observed, could lead to personal injury or damage to the instrument.

---

**IMPORTANT**

---

Contains precautions to be observed to protect against adverse conditions that may lead to damage to the instrument or a system failure.

---

**NOTE**

---

Contains precautions to be observed with regard to understanding operation and functions.

---

Some of the diagrams in this manual are partially omitted, described in writing, or simplified for ease of explanation. The screen drawings contained in the instruction manual may have a display position or characters (upper/lower case) that differ slightly from the full-scale screen to an extent that does not hinder the understanding of functions or monitoring of operation.

**■ Warranty**

- The warranty period of the instrument is written on the estimate sheet that is included with your purchase. Any trouble arising during the warranty period shall be repaired free of charge.
- Inquiries with regard to problems with the instrument shall be accepted by the sales outlet or our local dealer representative.
- Should the instrument be found to be defective, inform us of the model name and the serial number of the instrument together with a detailed description of nonconformance and a progress report. Outline drawings or related data will also be helpful for repair.
- Whether or not the defective instrument is repaired free of charge depends on the result of our inspection.

**● Conditions not eligible for charge-exempt repair.**

- Problems caused by improper or insufficient maintenance on the part of the customer.
- Trouble or damage caused by mishandling, misuse, or storage that exceeds the design or specification requirements.
- Problems caused by improper installation location or by maintenance conducted in a non-conforming location.
- Trouble or damage was caused by modification or repair that was handled by a party or parties other than our consigned agent.
- Trouble or damage was caused by inappropriate relocation following delivery.
- Trouble or damage was caused by fire, earthquake, wind or flood damage, lightning strikes or other acts of God that are not directly a result of problems with this instrument.

**■ Trademarks**

- HART is a trademark of the HART Communication Foundation.
- Registered trademarks or trademarks appearing in this manual are not designated by a TM or ® symbol.
- Other company names and product names used in this manual are the registered trademarks or trademarks of their respective owners.

## ■ ATEX Documentation

This procedure is only applicable to the countries in European Union.

GB

All instruction manuals for ATEX Ex related products are available in English, German and French. Should you require Ex related instructions in your local language, you are to contact your nearest Yokogawa office or representative.

DK

Alle brugervejledninger for produkter relateret til ATEX Ex er tilgængelige på engelsk, tysk og fransk. Skulle De ønske yderligere oplysninger om håndtering af Ex produkter på eget sprog, kan De rette henvendelse herom til den nærmeste Yokogawa afdeling eller forhandler.

I

Tutti i manuali operativi di prodotti ATEX contrassegnati con Ex sono disponibili in inglese, tedesco e francese. Se si desidera ricevere i manuali operativi di prodotti Ex in lingua locale, mettersi in contatto con l'ufficio Yokogawa più vicino o con un rappresentante.

E

Todos los manuales de instrucciones para los productos antiexplosivos de ATEX están disponibles en inglés, alemán y francés. Si desea solicitar las instrucciones de estos artículos antiexplosivos en su idioma local, deberá ponerse en contacto con la oficina o el representante de Yokogawa más cercano.

NL

Alle handleidingen voor producten die te maken hebben met ATEX explosiebeveiliging (Ex) zijn verkrijgbaar in het Engels, Duits en Frans. Neem, indien u aanwijzingen op het gebied van explosiebeveiliging nodig hebt in uw eigen taal, contact op met de dichtstbijzijnde vestiging van Yokogawa of met een vertegenwoordiger.

SF

Kaikkien ATEX Ex -tyyppisten tuotteiden käyttöohjeet ovat saatavilla englannin-, saksan- ja ranskankielisinä. Mikäli tarvitsette Ex -tyyppisten tuotteiden ohjeita omalla paikallisella kielellänne, ottakaa yhteyttä lähimpään Yokogawa-toimistoon tai -edustajaan.

P

Todos os manuais de instruções referentes aos produtos Ex da ATEX estão disponíveis em Inglês, Alemão e Francês. Se necessitar de instruções na sua língua relacionadas com produtos Ex, deverá entrar em contacto com a delegação mais próxima ou com um representante da Yokogawa.

F

Tous les manuels d'instruction des produits ATEX Ex sont disponibles en langue anglaise, allemande et française. Si vous nécessitez des instructions relatives aux produits Ex dans votre langue, veuillez bien contacter votre représentant Yokogawa le plus proche.

D

Alle Betriebsanleitungen für ATEX Ex bezogene Produkte stehen in den Sprachen Englisch, Deutsch und Französisch zur Verfügung. Sollten Sie die Betriebsanleitungen für Ex-Produkte in Ihrer Landessprache benötigen, setzen Sie sich bitte mit Ihrem örtlichen Yokogawa-Vertreter in Verbindung.

S

Alla instruktionsböcker för ATEX Ex (explosionssäkra) produkter är tillgängliga på engelska, tyska och franska. Om Ni behöver instruktioner för dessa explosionssäkra produkter på annat språk, skall Ni kontakta närmaste Yokogawakontor eller representant.

GR

Όλα τα εγχειρίδια λειτουργίας των προϊόντων με ATEX Ex διατίθενται στα Αγγλικά, Γερμανικά και Γαλλικά. Σε περίπτωση που χρειάζεστε οδηγίες σχετικά με Ex στην τοπική γλώσσα παρακαλούμε επικοινωνήστε με το πλησιέστερο γραφείο της Yokogawa ή αντιπρόσωπο της.

## SK

Všetky návody na obsluhu pre prístroje s ATEX Ex sú k dispozícii v jazyku anglickom, nemeckom a francúzskom. V prípade potreby návodu pre Ex-prístroje vo Vašom národnom jazyku, skontaktujte prosím miestnu kanceláriu firmy Yokogawa.

## CZ

Všechny uživatelské příručky pro výrobky, na něž se vztahuje nevybušné schválení ATEX Ex, jsou dostupné v angličtině, němčině a francouzštině. Požadujete-li pokyny týkající se výrobků s nevybušným schválením ve vašem lokálním jazyku, kontaktujte prosím vaši nejbližší reprezentační kancelář Yokogawa.

## LT

Visos gaminiø ATEX Ex kategorijos Eksploatavimo instrukcijos teikiami anglø, vokieèiø ir prancûzø kalbomis. Norëdami gauti prietaisø Ex dokumentacijà kitomis kalbomis susisiekite su artimiausiu bendrovës “Yokogawa” biuru arba atstovu.

## LV

Visas ATEX Ex kategorijas izstrādājumu Lietošanas instrukcijas tiek piegādātas angļu, vācu un franču valodās. Ja vēlaties saņemt Ex ierīšu dokumentāciju citā valodā, Jums ir jāsazinās ar firmas Jokogava (Yokogawa) tuvāko ofisu vai pārstāvi.

## EST

Kõik ATEX Ex toodete kasutamishendid on esitatud inglise, saksa ja prantsuse keeles. Ex seadmete muukeelse dokumentatsiooni saamiseks pöörduge lähima Iokagava (Yokogawa) kontori või esindaja poole.

## PL

Wszystkie instrukcje obsługi dla urządzeń w wykonaniu przeciwwybuchowym Ex, zgodnych z wymaganiami ATEX, dostępne są w języku angielskim, niemieckim i francuskim. Jeżeli wymagana jest instrukcja obsługi w Państwa lokalnym języku, prosimy o kontakt z najbliższym biurem Yokogawy.

## SLO

Vsi predpisi in navodila za ATEX Ex sorodni pridelki so pri roki v angleščini, nemščini ter francoščini. Če so Ex sorodna navodila potrebna v vašem tujejnem jeziku, kontaktirajte vaš najbliži Yokogawa office ili predstavnika.

## H

Az ATEX Ex műszerek gépkönyveit angol, német és francia nyelven adjuk ki. Amennyiben helyi nyelven kérik az Ex eszközök leírásait, kérjük keressék fel a legközelebbi Yokogawa irodát, vagy képviselőt.

## BG

Всички упътвания за продукти от серията ATEX Ex се предлагат на английски, немски и френски език. Ако се нуждаете от упътвания за продукти от серията Ex на родния ви език, се свържете с най-близкия офис или представителство на фирма Yokogawa.

## RO

Toate manualele de instructiuni pentru produsele ATEX Ex sunt in limba engleza, germana si franceza. In cazul in care doriti instructiunile in limba locala, trebuie sa contactati cel mai apropiat birou sau reprezentant Yokogawa.

## M

Il-manwali kollha ta' l-istruzzjonijiet għal prodotti marbuta ma' ATEX Ex huma disponibbli bl-Ingliż, bil-Ġermaniż u bil-Franċiż. Jekk tkun teħtieġ struzzjonijiet marbuta ma' Ex fil-lingwa lokali tiegħek, għandek tikkuntattja lill-eqreb rappreżentant jew ufficċju ta' Yokogawa.





### (3) Impact and Vibration

It is recommended that the instrument be installed in a location that is subject to a minimum amount of impact and vibration.

## 2.5 Use of a Transceiver

Although the temperature transmitter is designed to resist influence from high frequency noise; use of a transceiver in the vicinity of installation may cause problems. Installing the transmitter in an area free from high frequency noise (RFI) is recommended.

## 2.6 Insulation Resistance Test and Withstand Voltage Test



### CAUTION

- (1) Overvoltage of the test voltage that is so small that it does not cause a dielectric breakdown may in fact deteriorate insulation and lower the safety performance; to prevent this it is recommended that the amount of testing be kept to a minimum.
- (2) The voltage for the insulation resistance test must be 500 VAC or lower, and the voltage for the withstand voltage test must be 500 VAC or lower. Failure to heed these guidelines may cause faulty operation.
- (3) Where a built-in arrester is provided (suffix code: /A), the voltage for the insulation resistance test must be 100 VDC or lower, and the voltage for the withstand voltage test must be 100 VAC or lower. Failure to heed these guidelines may cause faulty operation.

Follow the steps below to perform the test, the wiring of the transmission line must be removed before initiating testing.

### 2.6.1 Insulation resistance test procedure

#### ■ Testing between the output terminal and input terminal

1. Lay transition wiring between the + terminal, the - terminal, and the check terminal of the terminal box.
2. Lay wiring across terminals 1, 2, 3, and 4 of the terminal box.
3. Connect the insulation resistance meter (with the power turned OFF) between the transition wiring of Steps 1 and 2 above. The polarity of the input terminals must be positive and that of the output terminals must be negative.

4. Turn the power of the insulation resistance meter ON and measure the insulation resistance. The duration of the applied voltage must be the period during which 100M $\Omega$  or more is confirmed (or 20M $\Omega$  if the unit is equipped with a built-in arrester).
5. Upon completion of the test, remove the insulation resistance meter, connect a 100K $\Omega$  resistor between the transition wiring, and allow the electricity to discharge. Do not touch the terminal with your bare hands while the electricity is discharging for more than 1 second.

#### ■ Testing between the output terminal and grounding terminal

1. Lay transition wiring between the + terminal, the - terminal, and the check terminal of the terminal box, then connect an insulation resistance meter (with the power turned OFF) between the transition wiring and the grounding terminal. The polarity of the transition wiring must be positive and that of the grounding terminal must be negative.
2. Turn the power of the insulation resistance meter ON and measure the insulation resistance. The duration of the applied voltage must be the period during which 100M $\Omega$  or more is confirmed (or 20M $\Omega$  if the unit is equipped with a built-in arrester).
3. Upon completion of the test, remove the insulation resistance meter, connect a 100K $\Omega$  resistor between the transition wiring and the grounding terminal, and allow the electricity to discharge. Do not touch the terminal with your bare hands while the electricity is discharging for more than 1 second.

#### ■ Testing between the input terminal and grounding terminal

1. Lay transition wiring between terminals 1, 2, 3, 4 and 5 of the terminal box, and connect the insulation resistor (with the power turned OFF) between the transition wiring and the grounding terminal. The polarity of the transition wiring must be positive and that of the grounding terminal must be negative.
2. Turn the power of the insulation resistance meter ON and measure the insulation resistance. The duration of the applied voltage must be the period during which 100M $\Omega$  or more is confirmed (or 20M $\Omega$  if the unit is equipped with a built-in arrester).
3. Upon completion of the test, remove the insulation resistance meter, connect a 100K $\Omega$  resistor between the transition wiring and the grounding terminal, and allow the electricity to discharge. Do not touch the terminal with your bare hands while the electricity is discharging for more than 1 second.

## 2.6.2 Withstand voltage test procedure

### ■ Testing between the output terminal and the input terminal

1. Lay transition wiring between the + terminal, the – terminal, and the check terminal of the terminal box.
2. Lay transition wiring between terminals 1, 2, 3, 4 and 5 of the terminal box.
3. Connect the withstand voltage tester (with the power turned OFF) between the transition wiring shown in Steps 1 and 2 above.
4. After setting the current limit value of the withstand voltage tester to 10mA, turn the power ON, and carefully increase the impressed voltage from 0V to the specified value.
5. The voltage at the specified value must remain for a duration of one minute.
6. Upon completion of the test, carefully reduce the voltage so that no voltage surge occurs.

### ■ Testing between the output terminal and the grounding terminal

1. Lay the transition wiring between the + terminal, the - terminal and the check terminal of the terminal box, and connect the withstand voltage tester (with the power turned OFF) between the transition wiring and the grounding terminal. Connect the grounding side of the withstand voltage tester to the grounding terminal.
2. After setting the current limit value of the withstand voltage tester to 10mA, turn the power ON, and gradually increase the impressed voltage from 0V to the specified value.
3. The voltage at the specified value must remain for a duration of one minute.
4. Upon completion of the test, carefully reduce the voltage so that no voltage surge occurs.

### ■ Testing between the input terminal and the grounding terminal

1. Lay the transition wiring across terminals 1, 2, 3, 4, and 5 of the terminal box and connect the withstand voltage tester (with the power turned OFF) between the transition wiring and the grounding terminal. Connect the grounding side of the withstand voltage tester to the grounding terminal.
2. After setting the current limit value of the withstand voltage tester to 10mA, turn the power ON, and gradually increase the impressed voltage from 0V to the specified value.
3. The voltage at the specified value must remain for a duration of one minute.
4. Upon completion of the test, carefully reduce the voltage so that no voltage surge occurs.

## 2.7 Installation of Explosion Protected Type Transmitters

In this section, further requirements and differences and for explosionproof type instrument are described. For explosionproof type instrument, the description in this chapter is prior to other description in this users manual.



### CAUTION

To preserve the safety of explosionproof equipment requires great care during mounting, wiring, and piping. Safety requirements also place restrictions on maintenance and repair activities. Please read the following sections very carefully.

### 2.7.1 CSA Certification

Model YTA110/CU1, YTA310/CU1 and YTA320/CU1 temperature transmitters can be selected the type of protection (CSA Intrinsically Safe, Non-incendive, or Explosionproof) for use in hazardous locations.

Note 1. For the installation of this transmitter, once a particular type of protection is selected, any other type of protection cannot be used. The installation must be in accordance with the description about the type of protection in this instruction manual.

Note 2. In order to avoid confusion, unnecessary marking is crossed out on the label other than the selected type of protection when the transmitter is installed.

#### a) CSA Intrinsically Safe Type/Non-incendive Type

Caution for CSA Intrinsically safe type. (Following contents refers “DOC No. ICS008-A13 P.1-1 and P.1-2”)

Note 1. Model YTA110/CU1, YTA310/CU1 and YTA320/CU1 temperature transmitters are applicable for use in hazardous locations:

Certificate 172608-0001053837

[For CSA C22.2]

- Applicable Standard: C22.2 No.0, C22.2 No.0.4, C22.2 No.25, C22.2 No.94, C22.2 No.142, C22.2 No.157, C22.2 No.213
- Intrinsically Safe for Class I, II, III, Division 1, Groups A, B, C, D, E, F & G.
- Non-incendive for Class I, II, Division 2, Groups A, B, C, D, E, F & G, Class III, Division 1.

- Encl. “Type 4X”
  - Temperature Class: T4
  - Ambient temperature: -40 to 60°C
- Note 2. Entity Parameters (Electrical/Non-incendive field wiring parameters)

- [Supply Circuit]
  - $V_{max} = 30\text{ V}$ ,  $I_{max} = 165\text{ mA}$ ,  $P_{max} = 0.9\text{ W}$
  - $C_i = 18\text{ nF}$ ,  $L_i = 730\text{ }\mu\text{H}$
- [Associated apparatus]
  - $V_{oc} \leq 30\text{ V}$ ,  $I_{sc} \leq 165\text{ mA}$ ,  $P_{max} \leq 0.9\text{ W}$
- [Sensor Circuit]
  - $V_{oc} = 9\text{ V}$ ,  $I_{sc} = 40\text{ mA}$ ,  $P_o = 90\text{ mW}$ ,
  - $C_a = 1\text{ }\mu\text{F}$ ,  $L_a = 10\text{ mH}$

Note 3. Installation

- All wiring shall comply with Canadian Electrical Code Part I and Local Electrical Codes.
- For the sensor circuitry, the above parameters for sensor circuit must be taken into account.
- Dust-tight conduit seal must be used when installed in class II and III environments.
- In any used safety barrier, output current must be limited by a resistor 'R' such that  $I_{sc} = V_{oc}/R$ .
- The safety barrier must be CSA certified, and the input voltage of the barrier must be less than  $250V_{rms}/V_{dc}$ .
- For non-incendive type, general purpose equipment must be CSA certified and the equipment which have non-incendive field wiring parameters.
- The instrument modification or parts replacement by other than authorized representative of Yokogawa Electric Corporation is prohibited and will void Canadian Standards Intrinsically safe and nonincendive Certification.

b) CSA Explosionproof Type

Caution for CSA Explosionproof type

Note 1. Model YTA110/CU1, YTA310/CU1 and YTA320/CU1 temperature transmitters are applicable for use in hazardous locations:

Certificate 1089576

[For CSA C22.2]

- Applicable Standard: C22.2 No.0, C22.2 No.0.4, C22.2 No.25, C22.2 No.30, C22.2 No.94, C22.2 No.142, C22.2 No.157, C22.2 No.213, C22.2 No.1010.1
- Explosionproof for Class I, Division 1, Groups B, C and D.
- Dust-ignitionproof for Class II, Groups E, F and G, Class III.
- Encl “Type 4X”
- Temperature Class: T6
- Ambient Temperature: -40 to 60°C
- Supply Voltage: 42 V dc max.
- Output Signal: 4 to 20 mA

Note 2. Wiring

- All wiring shall comply with Canadian Electrical Code Part I and Local Electrical Codes.
- In hazardous location, wiring shall be in conduit as shown in the figure.

**WARNING: A SEAL SHALL BE INSTALLED WITHIN 50 cm OF THE ENCLOSURE. UN SCELEMENT DOIT ÊTRE INSTALLÉ À MOINS DE 50 cm DU BOÎTIER.**

- When installed in Division 2, “FACTORY SEALED, CONDUIT SEAL NOT REQUIRED”.

Note 3. Operation

- Keep strictly the “WARNING” on the label attached on the transmitter.

**WARNING: OPEN CIRCUIT BEFORE REMOVING COVER. OUVRIRE LE CIRCUIT AVANT D'ENLEVER LE COUVERCLE.**

- Take care not to generate mechanical spark when access to the instrument and peripheral devices in hazardous location.

Note 4. Maintenance and Repair

- The instrument modification or parts replacement by other than authorized representative of Yokogawa Electric Corporation is prohibited and will void Canadian Standards Explosionproof Certification.

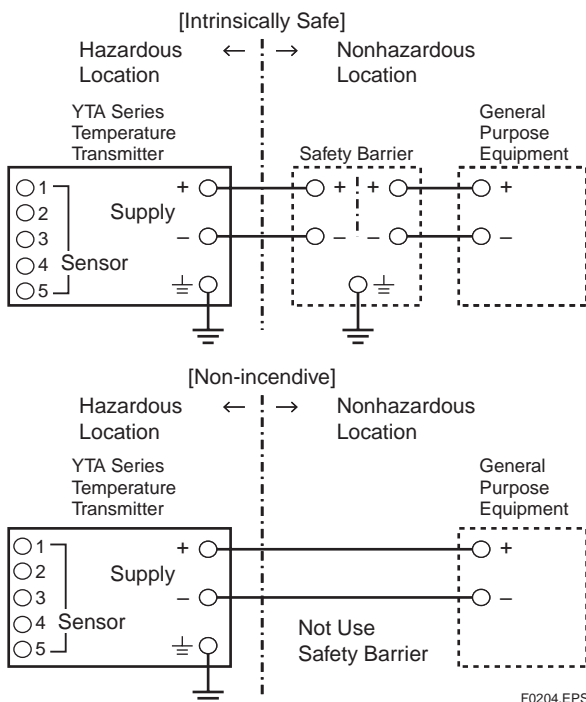

F0204.EPS

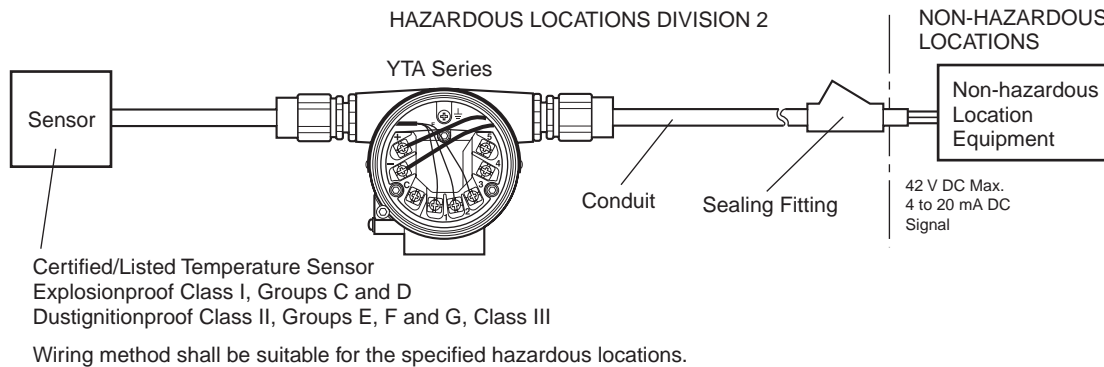
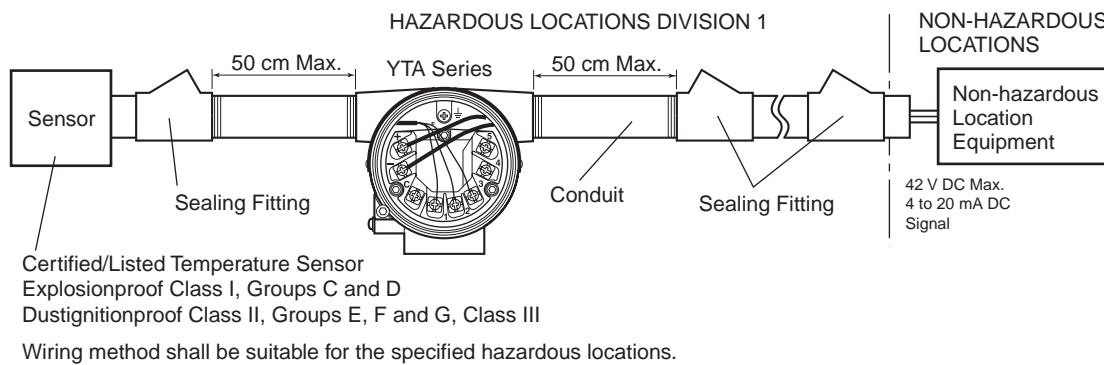

F0203.EPS

## 2.7.2 CENELEC ATEX (KEMA) Certification

Model YTA110/KU2, YTA310/KU2 and YTA320/KU2 temperature transmitters can be selected the type of protection (CENELEC ATEX(KEMA) Intrinsically Safe or CENELEC ATEX(KEMA) Flameproof or CENELEC ATEX Type of Protection “n”) for use in hazardous locations.

Note 1. For the installation of this transmitter, once a particular type of protection is selected, any other type of protection cannot be used. The installation must be in accordance with the description about the type of protection in this instruction manual.

Note 2. In order to avoid confusion, unnecessary marking is crossed out on the label other than the selected type of protection when the transmitter is installed.

### (1) Technical Data

#### a) CENELEC ATEX (KEMA) Intrinsically Safe Type

Caution for CENELEC ATEX (KEMA) Intrinsically safe type

Note 1. Model YTA110/KU2, YTA310/KU2 and YTA320/KU2 temperature transmitters for potentially explosive atmospheres:

- No. KEMA 02ATEX1026X

- Applicable Standard: EN 50014, EN 50020, EN 50284
- Type of Protection and Marking code: II 1G EEx ia IIC T5, T4
- Temperature Class: T5, T4
- Ambient Temperature: -40 to 70°C for T4, -40 to 50°C for T5
- Enclosure: IP67

#### Note 2. Electrical Data

- In type of explosion protection intrinsic safety II 1G EEx ia IIC only for connection to a certified intrinsically safe circuit with following maximum values:
  - [Supply circuit]
 

|  |                        |
|--|------------------------|
| $U_i = 30 \text{ V}$   | $I_i = 165 \text{ mA}$ |
| $P_i = 900 \text{ mW}$   |                        |
| Effective internal capacitance, $C_i = 20 \text{ nF}$          |                        |
| Effective internal inductance, $L_i = 660 \text{ }\mu\text{H}$ |                        |
  - [Sensor circuit]
 

|  |                       |
|--|-----------------------|
| $U_o = 8.6 \text{ V}$  | $I_o = 30 \text{ mA}$ |
| $P_o = 70 \text{ mW}$  |                       |
| Max. allowed external capacitance, $C_o = 3 \text{ }\mu\text{F}$ |                       |
| Max. allowed external inductance, $L_o = 20 \text{ mH}$          |                       |

#### Note 3. Installation

- All wiring shall comply with local installation requirements. (Refer to the installation diagram)

#### Note 4. Maintenance and Repair

- The instrument modification or parts replacement by other than authorized representative of Yokogawa Electric Corporation is prohibited and will void KEMA Intrinsically safe Certification.

**Note 5. Special condition for safe use**

- Because the enclosure of the Temperature Transmitter is made of aluminium, if it is mounted in an area where the use of category 1G apparatus is required, it must be installed such, that, even in the event of rare incidents, ignition source due to impact and friction sparks are excluded.

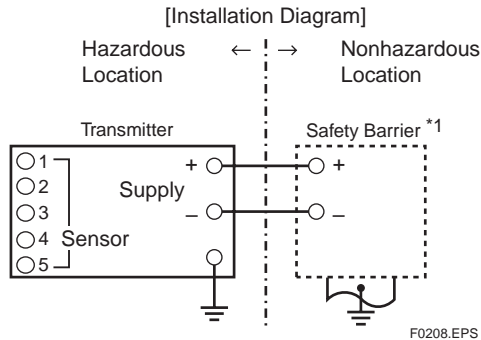

\*1: In any safety barriers used the output current must be limited by a resistor "R" such that  $I_{maxout} - U_z/R$ .

**b) CENELEC ATEX (KEMA) Flameproof Type and Dust Ignition Proof Type**

Caution for CENELEC ATEX (KEMA) Flameproof Type and Dust Ignition Proof Type

**Note 1.** Model YTA110/KU2, YTA310/KU2 and YTA320/KU2 temperature transmitters are applicable for use in hazardous locations:

- No. KEMA 07ATEX0130
- Applicable Standard: EN 60079-0, IEC 60079-1, EN 61241-0, EN 61241-1
- Type of Protection and Marking Code: II 2G Ex d IIC T6/T5, II 2D Ex tD A21 IP67 T70°C, T90°C
- Ambient Temperature for Gas Atmospheres: -40 to 75°C (T6), -40 to 80°C (T5)
- Ambient Temperature for Dust Atmospheres: -40 to 65°C (T70°C), -40 to 80°C (T90°C)
- Enclosure: IP67

**Note 2. Electrical Data**

- Supply voltage: 42 V dc max.
- Output signal: 4 to 20 mA

**Note 3. Installation**

- All wiring shall comply with local installation requirement.
- The cable entry devices shall be of a certified flameproof type, suitable for the conditions of use.

**Note 4. Operation**

- Keep strictly the "WARNING" on the label on the transmitter.

**WARNING: AFTER DE-ENERGIZING, DELAY 5 MINUTES BEFORE OPENING. WHEN THE AMBIENT TEMP.  $\cong$  70°C, USE THE HEATRESISTING CABLES OF HIGHER THAN 90°C.**

- Take care not to generate mechanical spark when access to the instrument and peripheral devices in hazardous location.

**Note 5. Maintenance and Repair**

- The instrument modification or parts replacement by other than authorized representative of Yokogawa Electric Corporation is prohibited and will void KEMA Flameproof Certification.

**c) CENELEC ATEX Type of Protection "n"****WARNING**

When using a power supply not having a non-incendive circuit, please pay attention not to ignite in the surrounding flammable atmosphere. In such a case, we recommend using wiring metal conduit in order to prevent the ignition.

Caution for CENELEC ATEX Type of Protection "n"

**Note 1.** Model YTA110/KU2, YTA310/KU2 and YTA320/KU2 temperature transmitters for potentially explosive atmospheres:

- Applicable standard: EN60079-15:2003
- Referential standard: IEC60079-0:1998, IEC60079-11:1999
- Type of Protection and Marking Code: II 3G EEx nL IIC T5, T4
- Temperature Class: T5, T4
- Ambient Temperature: -40 to 50°C for T5, -40 to 70°C for T4
- Enclosure: IP67

**Note 2. Electrical Data**

[Supply circuit]

$$U_i = 30 \text{ V}$$

Effective internal capacitance,  $C_i = 20 \text{ nF}$

Effective internal inductance,  $L_i = 660 \text{ } \mu\text{H}$

[Sensor circuit]

$$U_o = 8.6 \text{ V} \quad I_o = 30 \text{ mA} \quad P_o = 70 \text{ mW}$$

Max. allowed external capacitance,  $C_o = 3 \text{ } \mu\text{F}$

Max. allowed external inductance,  $L_o = 20 \text{ mH}$

**Note 3. Installation**

- All wiring shall comply with local installation requirements. (refer to the installation diagram)

**Note 4. Maintenance and Repair**

- The instrument modification or parts replacement by other than authorized representative of Yokogawa Electric Corporation is prohibited and will void Type of Protection “n” Certification.

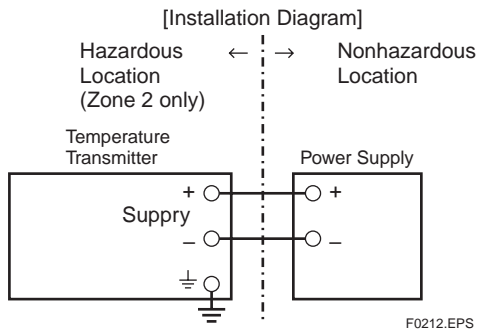

Ratings of the Power Supply are as follows:  
Maximum Voltage: 30 V

**(2) Electrical Connection**

The type of electrical connection is stamped near the electrical connection port according to the following marking.

| Screw Size          | Marking |
|---------------------|---------|
| ISO M20×1.5 female  | ⚠ M     |
| ANSI 1/2 NPT female | ⚠ A     |

T0201.EPS

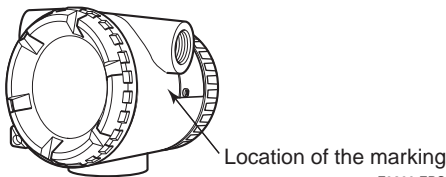

**(3) Installation**

**! WARNING**

All wiring shall comply with local installation requirement and local electrical code.

**(4) Operation**

**! WARNING**

- OPEN CIRCUIT BEFORE REMOVING COVER. INSTALL IN ACCORDANCE WITH THIS USER'S MANUAL
- Take care not to generate mechanical sparking when access to the instrument and peripheral devices in hazardous locations.

**(5) Maintenance and Repair**

**! WARNING**

The instrument modification or parts replacement by other than authorized Representative of Yokogawa Electric Corporation is prohibited and will void the certification.

**(6) Name Plate**

• Name plate for KU2

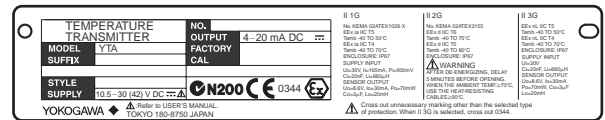

MODEL: Specified model code.  
SUFFIX: Specified suffix code.  
STYLE: Style code.  
SUPPLY: Supply voltage.  
NO.: Serial number and year of production\*1.  
OUTPUT: Output signal.  
FACTORY CAL: Specified calibration range.  
YOKOGAWA ♦ TOKYO 180-8750 JAPAN:  
The manufacturer name and the address\*2.

\*1: The third figure from the left shows the production year. The relationship between the production year and the third figure is shown below.

| The third figure       | F    | G    | H    | J    | K    | L    | M    |
|------------------------|------|------|------|------|------|------|------|
| The year of Production | 2006 | 2007 | 2008 | 2009 | 2010 | 2011 | 2012 |

T0202.EPS

For example, the production year of the product engraved in “NO.” column on the name plate as follows is 2006.

C2F616294

↑  
The year 2006

\*2: “180-8750” is a postal code which represents the following address.

2-9-32 Nakacho, Musashino-shi, Tokyo Japan

## 2.7.3 FM Certification

### a) FM Intrinsically Safe Type

Caution for FM Intrinsically safe type.

Note 1. Model YTA /FU1 temperature transmitter is applicable for use in hazardous locations

- Applicable Standard: FM 3600, FM 3610, FM 3611, FM 3810
- Intrinsically Safe for Class I, Division 1, Groups A, B, C & D.  
Class II, Division 1, Groups E, F & G and Class III, Division 1 Hazardous Locations.
- Outdoor hazardous locations, NEMA 4X.
- Temperature Class: T4
- Ambient temperature: -40 to 60°C

Note 2. Entity Parameters of the temperature transmitter:

- Supply Circuit (+ and -)
  - Sensor Circuit ( 1 to 5 )
- |                            |                              |
|----------------------------|------------------------------|
| $V_{max} : 30 \text{ V}$   | $V_{oc}/V_t : 9 \text{ V}$   |
| $I_{max} : 165 \text{ mA}$ | $I_{sc}/I_t : 40 \text{ mA}$ |
| $P_{max} : 0.9 \text{ W}$  | $C_a : 1 \mu\text{F}$        |
| $C_i : 18 \text{ nF}$      | $L_a : 10 \text{ mH}$        |
| $L_i : 730 \mu\text{H}$    |                              |

- For the sensor input circuitry, these entity parameters must be taken into account when installed.
- Installation Requirements between temperature transmitter and safety barrier:  
 $V_{oc} \leq V_{max}$ ,  $I_{sc} \leq I_{max}$ ,  $C_a \geq C_i + C_{cable}$ ,  $L_a \geq L_i + L_{cable}$   
 $V_{oc}$ ,  $I_{sc}$ ,  $C_a$  and  $L_a$  are parameters of the safety barrier.

Note 3. Installation

- The safety barrier must be FM approved.
- Input voltage of the safety barrier must be less than 250 Vrms/Vdc.
- Installation should be in accordance with ANSI/ISA RP12.6 "Installation of Intrinsically Safe Systems for Hazardous (Classified) Locations" and the National Electric Code (ANSI/NFPA 70).
- Intrinsically safe sensor must be FMRC Approved or be simple apparatus (a device which will neither generate nor store more than 1.2 V, 0.1 A, 25 mW or 20  $\mu\text{J}$ , ex. switches, thermocouples, LED's or RTD's).
- Dust-tight conduit seal must be used when installed in a Class II and III environments.

Note 4. Maintenance and Repair

- The instrument modification or parts replacement by other than authorized representative of Yokogawa Electric Corporation is prohibited and will void Factory Mutual Intrinsically safe and Nonincendive Approval.

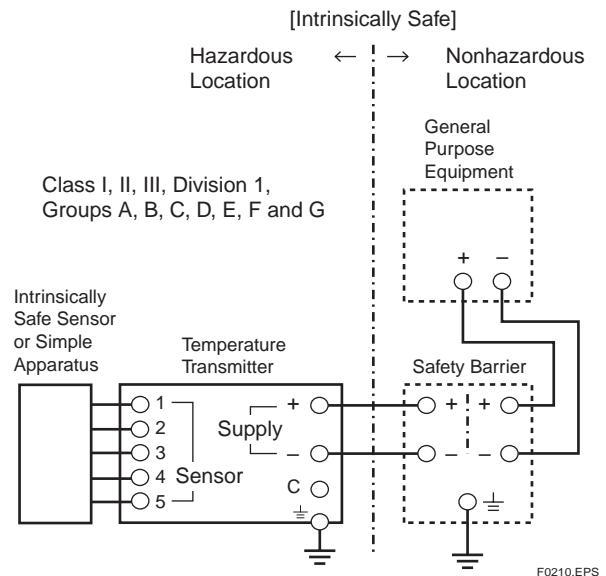

### b) FM Non-incendive Type

Caution for FM Non-incendive type.

Note 1. Model YTA /FU1 temperature transmitter is applicable for use in hazardous locations

- Applicable Standard: FM 3600, FM 3610, FM 3611, FM 3810
- Non-incendive for Class I, Division 2, Groups A, B, C & D.  
Class II, Division 2, Groups E, F & G and Class III, Division 1 Hazardous Locations.
- Outdoor hazardous locations, NEMA 4X.
- Temperature Class: T4
- Ambient temperature: -40 to 60°C

Note 2. Non-incendive field wiring Parameters of the temperature transmitter:

- Supply Circuit (+ and -)
  - Sensor Circuit ( 1 to 5 )
- |                            |                              |
|----------------------------|------------------------------|
| $V_{max} : 30 \text{ V}$   | $V_{oc}/V_t : 9 \text{ V}$   |
| $I_{max} : 165 \text{ mA}$ | $I_{sc}/I_t : 40 \text{ mA}$ |
| $P_{max} : 0.9 \text{ W}$  | $C_a : 1 \mu\text{F}$        |
| $C_i : 18 \text{ nF}$      | $L_a : 10 \text{ mH}$        |
| $L_i : 730 \mu\text{H}$    |                              |

- For the sensor input circuitry, these non-incendive parameters must be taken into account when installed.
- Installation Requirements between temperature transmitter and general purpose equipment:  
 $V_{oc} \leq V_{max}$ ,  $I_{sc} \leq I_{max}$ ,  $C_a \geq C_i + C_{cable}$ ,  $L_a \geq L_i + L_{cable}$   
 $V_{oc}$ ,  $I_{sc}$ ,  $C_a$  and  $L_a$  are non-incendive field wiring parameters of general purpose equipment.

Note 3. Installation

- The general purpose equipment must be FM approved which have non-incendive field wiring parameters.

- Installation should be in accordance with ANSI/ISA RP12.6 “Installation of Intrinsically Safe Systems for Hazardous (Classified) Locations” and the National Electric Code (ANSI/NFPA 70).
- non-incendive sensor must be FMRC Approved or be simple apparatus (a device which will neither generate nor store more than 1.2 V, 0.1 A, 25 mW or 20  $\mu$ J, ex. switches, thermocouples, LED’s or RTD’s).
- Dust-tight conduit seal must be used when installed in a Class II and III environments.

#### Note 4. Maintenance and Repair

- The instrument modification or parts replacement by other than authorized representative of Yokogawa Electric Corporation is prohibited and will void Factory Mutual Intrinsically safe and Nonincendive Approval.

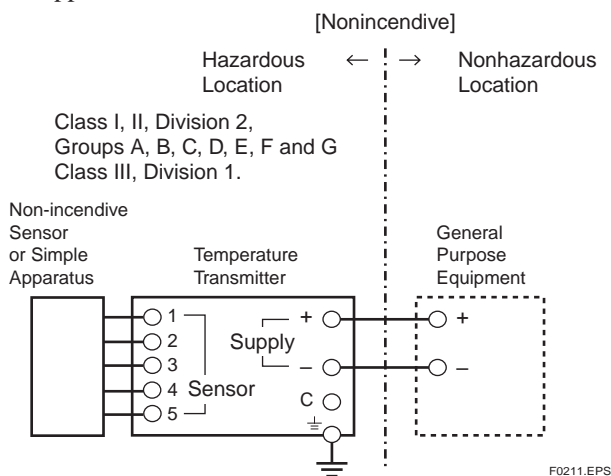

#### c) FM Explosionproof Type

Caution for FM Explosionproof type

Note 1. Model YTA /FU1 and YTA /FF1 temperature transmitters are applicable for use in hazardous locations:

- Applicable Standard: FM 3600, FM 3615, FM 3810, NEMA 250
- Explosionproof for Class I, Division 1, Groups A, B, C, and D.
- Dust-ignitionproof for Class II/III, Division 1, Groups E, F and G.
- Enclosure rating: NEMA 4X.
- Temperature Class: T6
- Ambient Temperature:  $-40$  to  $60^{\circ}\text{C}$
- Supply Voltage: 42 V dc max.
- Output signal: 4 to 20 mA

#### Note 2. Wiring

- All wiring shall comply with National Electrical Code ANSI/NEPA70 and Local Electrical Codes.
- “FACTORY SEALED, CONDUIT SEAL NOT REQUIRED”.

#### Note 3. Operation

- Keep strictly the “WARNING” on the nameplate attached on the transmitter.

**WARNING: OPEN CIRCUIT BEFORE REMOVING COVER. “FACTORY SEALED, CONDUIT SEAL NOT REQUIRED”. INSTALL IN ACCORDANCE WITH THE INSTRUCTION MANUAL IM 1C50B1.**

- Take care not to generate mechanical spark when access to the instrument and peripheral devices in hazardous location.

#### Note 4. Maintenance and Repair

- The instrument modification or parts replacement by other than authorized representative of Yokogawa Electric Corporation is prohibited and will void Factory Mutual Explosionproof Approval.

### 2.7.4 TIIS Certification

#### a) TIIS Flameproof Type

The model YTA /JF3 temperature transmitter, which has obtained certification according to technical criteria for explosion-protected construction of electric machinery and equipment (Standards Notification No.556 from the Japanese Ministry of Labor) conforming to IEC standards, is designed for hazardous areas where explosive gases and/or inflammable vapors may be present. (This allows installation in Division 1 and 2 areas)

To preserve the safety of flameproof equipment requires great care during mounting, wiring, and piping. Safety requirements also place restrictions on maintenance and repair activities. Users absolutely must read “Installation and Operating Precautions for TIIS Flameproof Equipment” at the end of this manual.



#### WARNING

The terminal cover should not be opened at least for three minutes after the power is turned off.

The terminal section of the flameproof YTA series is made of resin-filled, explosion-protected construction. The technical standards for this flameproof construction require that the possibility of explosion resulting from a prospective short-circuit current<sup>1</sup> of up to 4000 A be prevented even for cases when external power supply circuits are short-circuited accidentally. Install a fuse or a circuit breaker having a breaking capacity of at least 4000 A in the higher-order power line connected to the YTA



series. The breaking capacity refers to the upper limit of current that can be cut off. Normally, a fuse or a circuit breaker having a breaking capacity of greater than 5000 A is used in power supply circuits. Confirm that this is true with your factory. No extra measures need be taken after the confirmation.

Note that the rated current of the YTA series in terms of explosion protection is 4 to 20 mA; keep the input current of the YTA series within the appropriate range.

\*1: Refers to a current that flows when a fuse in a circuit is substituted with a connecting metal piece having virtually no impedance and the circuit is then shorted. For AC circuits, this current is represented by a root-mean-square value (JIS C6575).

### 2.7.5 SAA Certification

Model YTA110/SU1, YTA310/SU1 and YTA320/SU1 temperature transmitters can be selected the type of protection (SAA Intrinsically Safe, Type of Protection “n” or Flameproof) for use in hazardous locations.

Note 1. For the installation of this transmitter, once a particular type of protection is selected, any other type of protection cannot be used. The installation must be in accordance with the description about the type of protection in this instruction manual.

Note 2. In order to avoid confusion, cross out unnecessary marking on the label other than the selected type of protection when the transmitter is installed.

#### a) SAA Intrinsically Safe/Type N Type

Caution for SAA Intrinsically safe/Type n type

Note 1. Model YTA110/SU1, YTA310/SU1 and YTA320/SU1 temperature transmitters for potentially explosive atmospheres:

- Certificate: AUS Ex 3652X
- Applicable Standard: AS2380.1, AS2380.7, AS2380.9
- Type of Protection and Marking code:
  - Ex ia IIC T4 (Tamb=70°C) IP66/67 Zone 0
  - Ex n IIC T4 (Tamb=70°C) IP66/67 Zone 2
- Ambient Temperature: -40 to 70°C

Note 2. Entity Parameter

- In type of explosion protection only for connection to a certified intrinsically safe/type n circuit with following maximum values:

[Input parameters (terminals +&-/C)]

Maximum Input Voltage(Ui) = 30 V  
 Maximum Input Current(Ii) = 165 mA  
 Maximum Input Power(Pi) = 0.9 W  
 Maximum Internal Capacitance(Ci) = 30.2 nF  
 Maximum Internal Inductance(Li) = 738 μH

[Output parameters (terminals 1 to 5)]

Maximum Output Voltage(Uo) = 8.6 V  
 Maximum Output Current(Io) = 30 mA  
 Maximum Output Power(Po) = 62 mW  
 Maximum External Capacitance = 1 μF  
 Maximum External Inductance = 20 mH  
 Maximum External Connected L/R = 0.5mH/Ω

Note 3. Installation

- All wiring shall comply with Australian Standards.
- The input and output cables are to be installed either as separate cables or as separate screened circuits.
- Certified IP66/67 glands or plugs must be used on the enclosure cable entries.

Note 4. Maintenance and Repair

- The instrument modification or parts replacement by other than authorized representative of Yokogawa Electric Corporation is prohibited and will void SAA Certification.

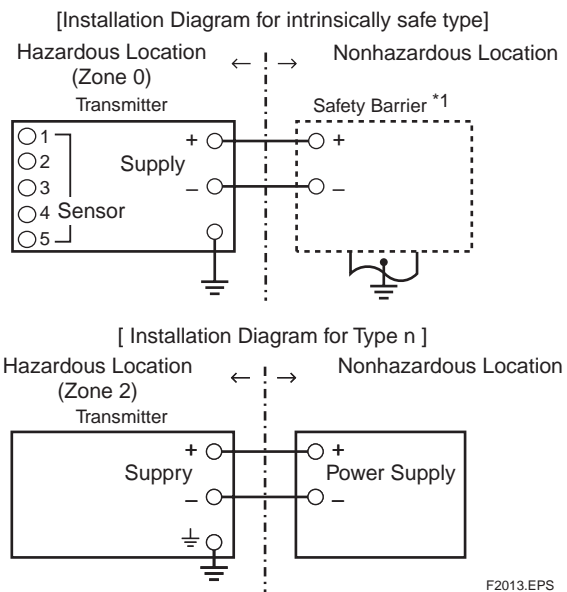

\*1: In any safety barriers used the output current must be limited by a resistor “R” such that  $I_{maxout} < U_z/R$ .

#### b) SAA Flameproof Type

Caution for SAA Flameproof Type

Note 1. Model YTA110/SU1, YTA310/SU1 and YTA320/SU1 temperature transmitters for potentially explosive atmospheres:

- Certificate: AUS Ex 3640
- Applicable Standard: AS2380.1, AS2380.2
- Type of Protection and Marking Code:
  - Ex d IIC T6(Tamb 75°C) IP66/67 Zone 1
- Ambient Temperature: -40 to 75°C

Note 2. Electrical Data

- Supply voltage: 42 V dc max.
- Output signal: 4 to 20 mA

Note 3. Installation

- All wiring shall comply with Australian Standards.
- The cable entry devices shall be of a certified flameproof type, suitable for the conditions of use.

**Note 4. Operation**

- Keep strictly the “WARNING” on the label on the transmitter.

**WARNING: WAIT 5 MIN. AFTER POWER-DISCONNECTION, BEFORE OPENING THE ENCLOSURE. WHEN THE AMBIENT TEMP.  $\geq 70^{\circ}\text{C}$ , USE THE HEATRESISTING CABLES OF HIGHER THAN  $90^{\circ}\text{C}$**

- Take care not to generate mechanical spark when access to the instrument and peripheral devices in hazardous location.

**Note 5. Maintenance and Repair**

- The instrument modification or parts replacement by other than authorized representative of Yokogawa Electric Corporation is prohibited and will void SAA Certification.

**2.7.6 IECEx Certification****a) IECEx Flameproof Type and Dust Ignition Proof Type**

Caution for IECEx flameproof type and Dust Ignition Proof Type

**Note 1.** Model YTA110/SF2, YTA310/SF2, and YTA320/SF2 temperature transmitters are applicable for use in hazardous locations:

- No. IECEx KEM 07.0044
- Applicable Standard: IEC 60079-0, IEC 60079-1, IEC 61241-0, IEC 61241-1
- Type of Protection and Marking Code: Ex d IIC T6/T5, Ex tD A21 IP67 T70°C, T90°C
- Ambient Temperature for Gas Atmospheres:  $-40$  to  $75^{\circ}\text{C}$  (T6),  $-40$  to  $80^{\circ}\text{C}$  (T5)
- Ambient Temperature for Dust Atmospheres:  $-40$  to  $65^{\circ}\text{C}$  (T70°C),  $-40$  to  $80^{\circ}\text{C}$  (T90°C)
- Enclosure: IP67

**Note 2. Electrical Data**

- Supply voltage: 42 V dc max.
- Output signal: 4 to 20 mA

**Note 3. Installation**

- All wiring shall comply with local installation requirement.
- The cable entry devices shall be of a certified flameproof type, suitable for the conditions of use.

**Note 4. Operation**

- Keep strictly the “WARNING” on the label on the transmitter.

**WARNING: AFTER DE-ENERGIZING, DELAY 5 MINUTES BEFORE OPENING. WHEN THE AMBIENT TEMP.  $\geq 70^{\circ}\text{C}$ , USE THE HEATRESISTING CABLES OF HIGHER THAN  $90^{\circ}\text{C}$ .**

- Take care not to generate mechanical spark when access to the instrument and peripheral devices in hazardous location.

**Note 5. Maintenance and Repair**

- The instrument modification or parts replacement by other than authorized representative of Yokogawa Electric Corporation is prohibited and will void IECEx Flameproof Certification.

**2.8 EMC Conformity Standards**

EN61326, AS/NZS CISPR11

**NOTE**

YOKOGAWA recommends customer to apply the Metal Conduit Wiring or to use the twisted pair Shield Cable for signal wiring to conform the requirement of EMC Regulation, when customer installs the YTA Series Transmitters to the plant.

**2.9 Low Voltage Directive**

Applicable standard: EN61010-1

**(1) Pollution Degree 2**

“Pollution degree” describes the degree to which a solid, liquid, or gas which deteriorates dielectric strength or surface resistivity is adhering. “2” applies to normal indoor atmosphere. Normally, only non-conductive pollution occurs. Occasionally, however, temporary conductivity caused by condensation must be expected.

**(2) Installation Category I**

“Overvoltage category(Installation category)” describes a number which defines a transient overvoltage condition. It implies the regulation for impulse withstand voltage. “I” applies to electrical equipment which is supplied from the circuit when appropriate transient overvoltage control means (interfaces) are provided.

# 3. PART NAMES AND FUNCTIONS

## 3.1 Part Names

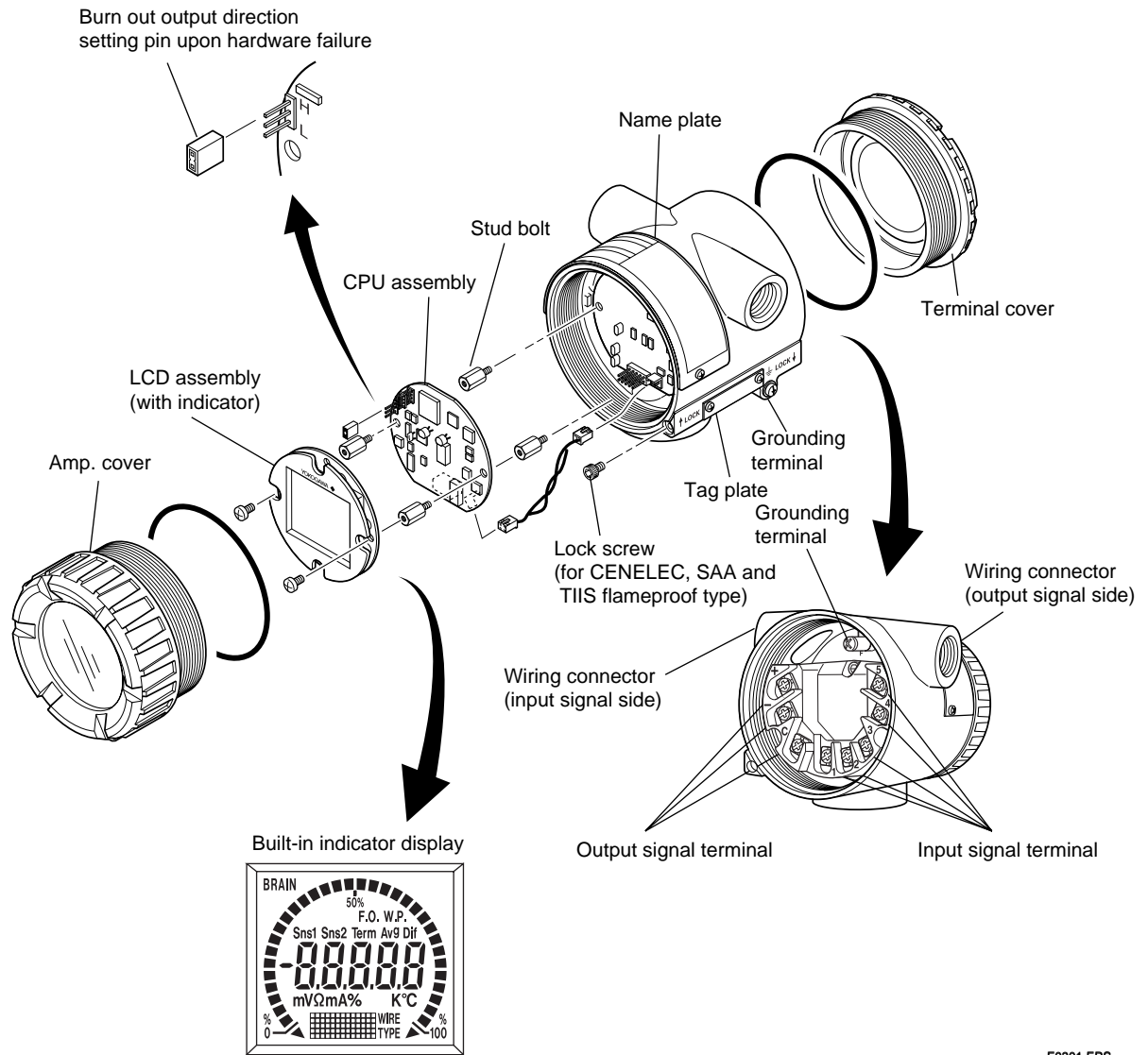

F0301.EPS



Figure 3.1 Part Names

## 3.2 Setting the Hardware Error Burnout Change-over Switch

The temperature transmitter is equipped with a hardware error burnout function used to set the output direction upon hardware error, and a sensor burnout function that sets the direction of the output in the event of burnout of the temperature sensor. When factory-shipped under normal conditions, the output of both hardware error burnout and sensor burnout are set to HIGH, but if suffix code /C1 is specified, the hardware error burnout is set to LOW (-5%) output, and sensor burnout is set to LOW (-2.5%) output, respectively. The setting of the direction of output from burnout can be changed.

To change the direction of output arising from burnout, switch the setting pin on the CPU assembly (see Figure 3.1 and Table 3.1). To change the direction of output arising out of sensor burnout, a dedicated hand-held terminal is required to rewrite the parameters within the transmitter. For details, refer to the separate instruction manual, IM 01C50T01-01E “HART Protocol” or IM 01C50T03-01E “BRAIN Protocol”.

**Table 3.1 Output Direction Setting Pins for Hardware Error Burnout**

| Pin position   | Hardware error burnout direction | Hardware error burnout output | Remark                                      |
|--|----------------------------------|-------------------------------|---|
|  H<br>L | HIGH                             | 110% or more<br>(21.6 mA DC)  | Set to HIGH upon shipment from the factory  |
|  H<br>L | LOW                              | -5% or less<br>(3.2 mA DC)    | Set to LOW when suffix code /C1 is provided |

T0301.EPS

## 3.3 Built-in Indicator Display Function

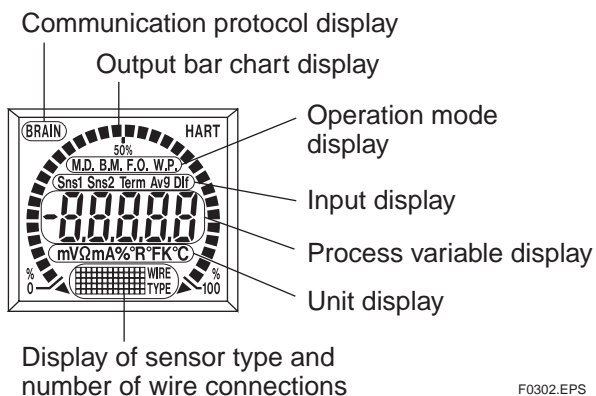

F0302.EPS

**Figure 3.2 Built-in Indicator Display Function**

### (1) Output bar chart display

The output value is displayed in a bar chart. Resolution of the bar chart is to the extent of 32 divisions (each increment is about 3.125%). If the output exceeds 0% or 100%, ▼ is lit. The bar chart can be toggled ON/OFF using the bar chart display parameter.

### (2) Communication protocol display

The indicator is on in accordance with each communication protocol.

### (3) Operation mode display

Lit when each operation mode is activated.

M.D.: Lit when the multidrop mode of HART communication specification is activated.

B.M.: Lit during burst mode transfer of HART communication specification.

F.O.: Lit when manual mode is active.

W.P.: Lit when write protect status is active.

### (4) Input display

Indicates the type of input in accordance with the value shown in the column in Item (5).

Sns1: Meant to show the process variable allocated to Sensor 1.

Sns2: Meant to show the process variable allocated to Sensor 2. (Can be displayed only with the YTA320.)

Term: Meant to show the temperature of the terminal box of the temperature transmitter.

Avg: Meant to show the average of the process variable allocated to Sensor1 and Sensor2. (Can be displayed only with the YTA320.)

Dif: Meant to show the difference of the process variable allocated to Sensor1 and Sensor2. (Can be displayed only with the YTA320.)

### (5) Process variable display

Displays the process variable or output value. The value is displayed down to the second decimal position if the integer part is less than three digits, or down to the first decimal position if the integer part is 4 digits. If the value is negative, the minus (–) sign is lit. For process variables, the indicators for each item specified in the column of input display in Item (4) and the unit column in Item (6) are lit. For output value, % or mA in the unit column in Item (6) is lit. When burnout of the temperature sensor is identified, or the temperature transmitter is found abnormal, an error code flashes. For a list of error codes, refer to “Error code table” in Section 6.4.

**(6)Unit display**

The unit specified as the unit of process in the process variable display column in Item (5) is lit. The output display is fixed to mA or %.

**(7)Display of sensor type and number of wire connections**

Displays process variable/output items, the number of sensor wiring connections and the multidrop address in dot matrix (only applies to HART communication). In the event of hardware error, "FAIL" is displayed.

**Process variable:** To display the process variable value in the process variable display in Item (5), display the type of applicable process variable ("PV", "SV", "TV").

**Output display:** To display the output value in the process variable display in Item (5), display "OUT". During the output of sensor burnout, "Abn" and "OUT" are alternately displayed.

**WIRE:** Displays the number of wiring connections. There are two wiring connections for thermocouple input, while there are two to four connections for thermometer resistor; these are displayed alternately with the sensor type. The display can be hidden by setting an applicable parameter. Note that the DIF and AVG display does not allow the sensor type to be displayed.

**TYPE:** Displays the type of sensor. Note that the DIF and AVG display does not allow the sensor type to be displayed. If the sensor is custom-ordered, "Z1" and "Z2" are displayed.

**Multidrop address:** If the multidrop address is 1 through 15 in HART communication, the output display brings up these addresses instead of displaying "OUT".

Upon shipment from the factory, the indicator is set as follows.

**Table 3.2 Setting of Indicator upon Shipment from the Factory**

| Display location                                      | Contents   |
|---|--|
| Output bar chart display                              | Output bar chart display is on.                              |
| Input display   | Sns1 is lit.   |
| Process variable display                              | PV value and output value (mA) are alternately displayed.    |
| Unit display  | The unit specified upon shipped from factory and mA are lit. |
| Display of sensor type and number of wire connections | "PV" and "OUT" are displayed alternately.                    |

T0302.EPS

# 4. INSTALLATION

## IMPORTANT

- When performing on-site pipe fitting work that involves welding, use care to prevent outflow of the welding current into the transmitter.
- Do not use the transmitter as a foothold for installation.

- For details of choosing the installation location, refer to the guidelines outlined in Section 2.4, “Choosing the installation location”.
- The mounting bracket shown in Figure 4.1 is used for the transmitter and is installed on 50A (2B) pipe. It can be installed either on a horizontal pipe and a vertical pipe or on a wall.
- To install the mounting bracket on the transmitter, torque the transmitter lock screw (1) to about 20 to 30N·m.

### Horizontal Pipe Mounting

- When using a horizontal pipe mounting bracket

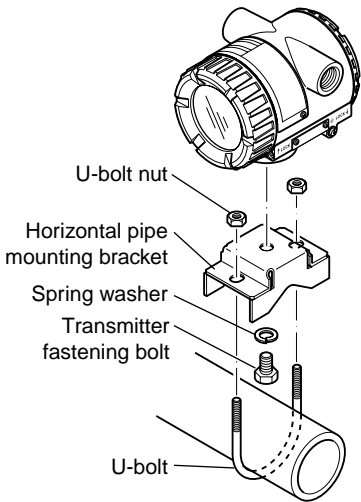

- When using a vertical pipe mounting bracket

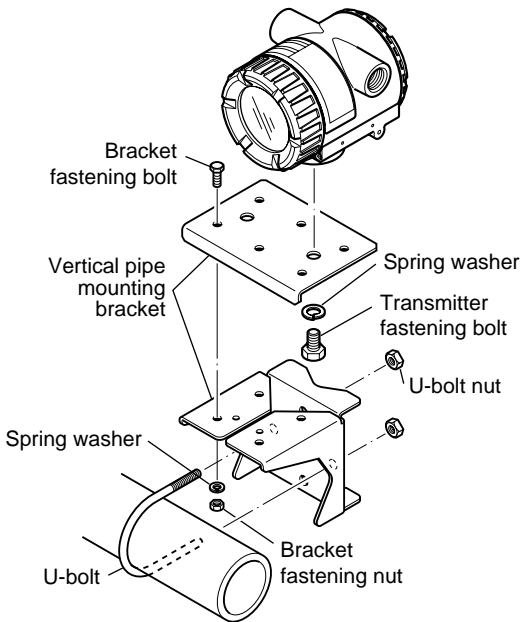

### Vertical Pipe Mounting

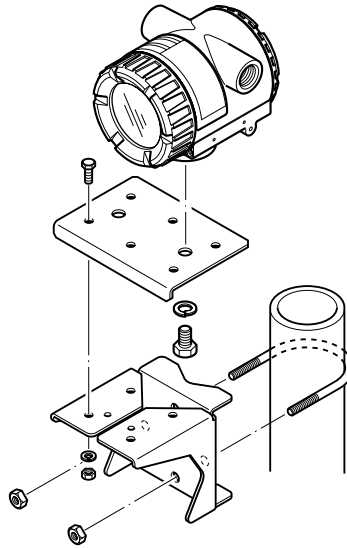

### Wall Mounting

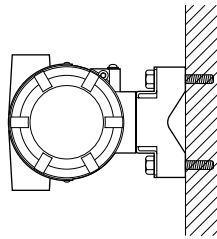

Note: Wall mounting bolts are user-supplied.

Figure 4.1 Mounting the Transmitter

F0401.EPS

# 5. WIRING

## 5.1 Notes on Wiring



### IMPORTANT

- Apply a waterproofing sealant to the threads of the connection port. (It is recommended that you use non-hardening sealant made of silicon resin for waterproofing.)
- Lay wiring as far away as possible from electrical noise sources such as large transformers, motors and power supplies.
- Remove the wiring connection dust-caps before wiring.
- To prevent electrical noise, the signal cable and the power cable must not be housed in the same conduit.
- The terminal box cover is locked by an Allen head bolt (a shrouding bolt) on CENELEC, SAA and TIIS flameproof type transmitters. When the shrouding bolt is driven clockwise by an Allen wrench, it is going in and cover lock is released, and then the cove can be opened by hands. See Subsection 6.3 “Disassembly and Reassembly” for details.

## 5.2 Loop Construction

The YTA is a two-wire temperature transmitter that uses the output power supply wiring and signal wiring alternately.

The transmission loop requires DC power. Connect the transmitter with the distributor as shown in Figure 5.1 or Figure 5.2.

For the transmission loop, the load resistance of the distributor or other instrument to be installed in the loop and the lead wire must be within the range shown in Figure 5.3.

For details of communication requirements, refer to the additional reference materials, IM 01C50T03-01E “YTA Series BRAIN Communication”, and IM 01C50T01-01E “YTA Series HART Communication”.

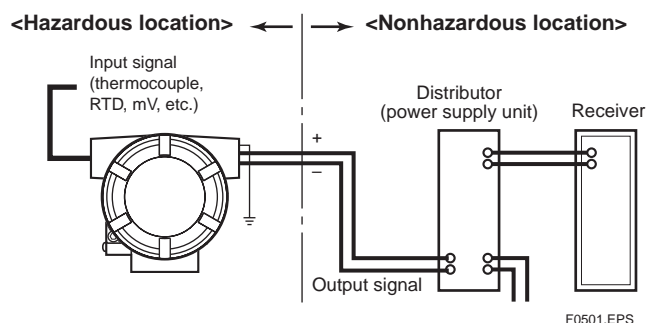

Figure 5.1 Loop Construction (for General-use Type and Flameproof Type)

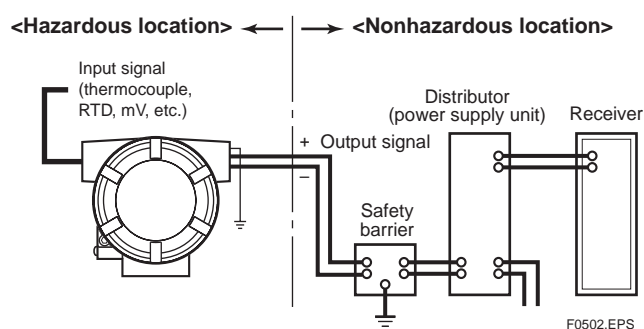

Figure 5.2 Loop Construction (for Intrinsically Safe Type)

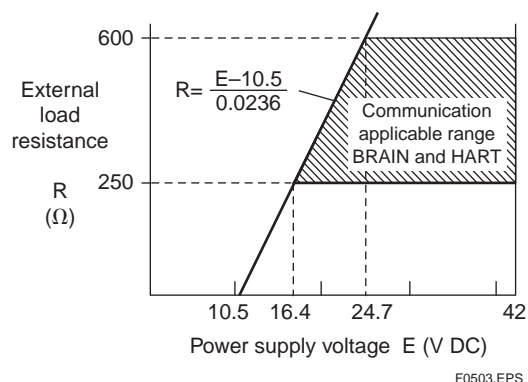

Figure 5.3 Relation between Power Supply Voltage and Load Resistance

Note: For intrinsic safe explosion-proof type units, the internal resistance of the safety barrier is also included in the load resistance.

## 5.3 Cable Selection

### 5.3.1 Input signal Cable Selection

A dedicated cable is used for connection between the temperature sensor and the temperature transmitter. When a thermocouple is used as the temperature sensor, a compensation wire must be used that is appropriate for the type of thermocouple (refer to compensating cables for JIS C 1610/IEC584-3 thermocouples). When a resistance temperature sensor (RTD) is used as the temperature sensor, 2-core/3-core/4-core cable must be used (refer to resistance thermometer sensor JIS C 1604/IEC751). The terminal of the dedicated cable is a 4 mm screw.

### 5.3.2 Output Signal Cable Selection

- With regard to the type of wire to be used for wiring, use twisted wires or cables with performance equivalent of 600V vinyl insulated cable (JIS C3307).
- For wiring in areas susceptible to electrical noise, use shielded wires.
- For wiring in high or low temperature areas, use wires or cables suitable for such temperatures.
- For use in an atmosphere where harmful gases or liquids, oil, or solvents are present, use wires or cables made of materials resistant to those substances.
- It is recommended that a self-sealing terminal with insulation sleeve (4-mm screw) be used for lead wire ends.



### WARNING

If the YTA is T1IS flameproof and the ambient temperature is 50°C or more, use an external cable having a maximum allowable heat resistance of at least 70°C in consideration of the instrument's generation of heat or the cable's self-heating.

## 5.4 Cable and Terminal Connections

### 5.4.1 Input Terminal Connections



### NOTE

It is recommended that the terminals be connected in the order of input terminal (1) and output terminal (2).



### CAUTION

When wiring, pay attention not to damage the cable and cores. All the cores of the cable must have the sufficient insulation around them.

STEP 1  
(1)

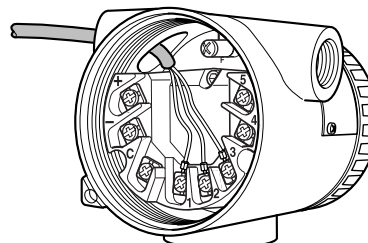

a. Cable connection to thermometer resistor (RTD), 3-wire

STEP 2  
(2)

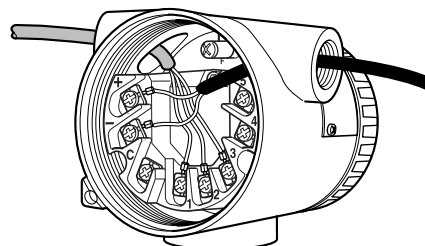

b. Power supply cable connection

F0504.EPS

Figure 5.4 Terminal Connection Procedure

■ The temperature sensor is to be connected as shown in Figures 5.6 and 5.7.

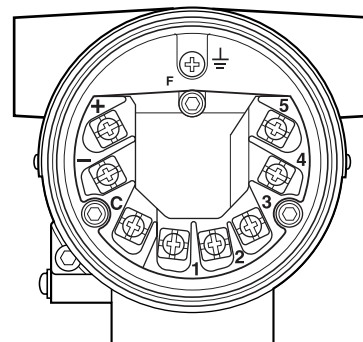

F0505.EPS

Figure 5.5 Terminal diagram



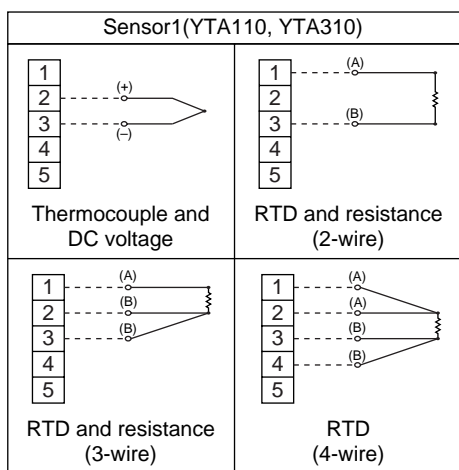

F0506.EPS

Figure 5.6 YTA110 and YTA310 Input Terminal Wire Connection Diagram

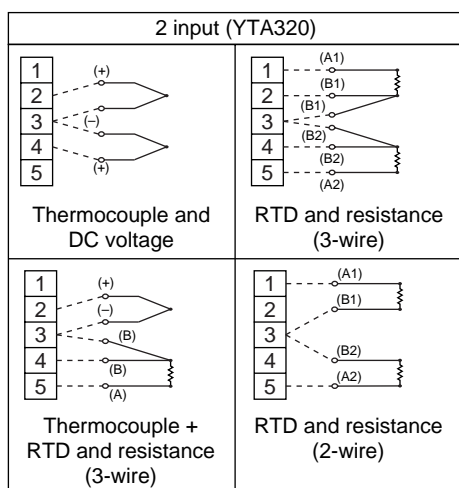
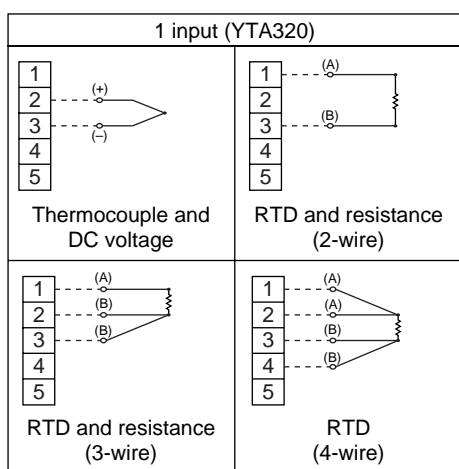

Figure 5.7 YTA320 Input Terminal Wire Connection Diagram

### 5.4.2 Output Terminal Connection

#### (1) Connection of output signal/power supply cable

Connect the output signal cable (shared with the power supply cable) to the – terminal and the + terminal. For details, refer to Figure 5.2, “Loop construction”.

#### (2) Connection of wiring for field indicator

Connect the lead wire for the field indicator with the – terminal and the C terminal.

Note: Use a field indicator with an internal resistance of 10W or less.

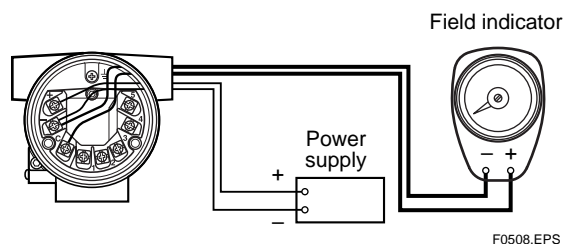

F0508.EPS

Figure 5.8 Connection to Field Indicator

#### (3) Connection of check meter

Connect the check meter with the – terminal and the C terminal.

The current signal of output signal 4 to 20 mA DC is output from the – terminal and the C terminal.

Note: Use a check meter with internal resistance of 10Ω or less.

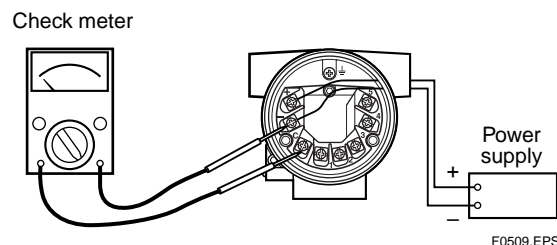

F0509.EPS

Figure 5.9 Check Meter Connection

## 5.5 Wiring Cautions

### (1) General-use Type and Intrinsically Safe Type

Use metal conduit wiring or a waterproof gland (metal wiring conduit JIS F 8801) for cable wiring.

- Apply nonhardening sealant to the threads of the wiring tap and a flexible fitting for secure waterproofing. Figure 5.10 shows an example of wiring on the output side. This example also applies to the wiring on the input side.

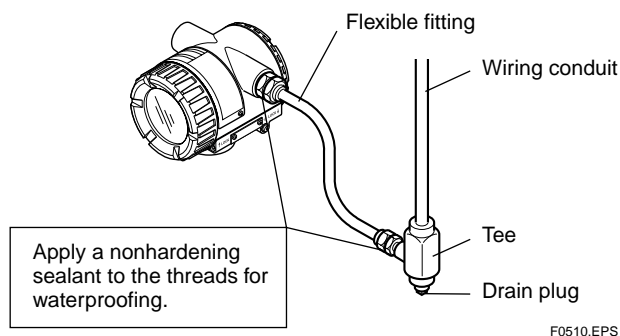

Figure 5.10 Example of Wiring Using a Wiring Conduit

### (2) TIIS Flameproof Type

Wire cables through a flameproof packing adapter, or using a flameproof metal conduit.

#### ■ Wiring cable through flameproof packing adapter for only TIIS flameproof type (see Figure 5.11)

- Use only flameproof packing adapters approved by Yokogawa.
- Apply a nonhardening sealant to the terminal box connection port and to the threads on the flameproof packing adapter for waterproofing.

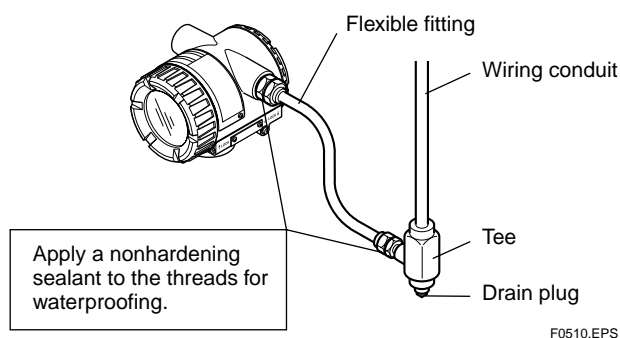

Figure 5.11 Typical Cable Wiring Using Flameproof Packing Adapter

- Measure the cable outer diameter in two directions to within 0.1mm.
- Calculate the average of the two diameters, and use packing with an internal diameter nearest to this value from among the three provided (see Table 5.1).

Table 5.1 Flameproof Packing and Appropriate Cable Outer Diameters

| Wiring Port Thread Diameter | Appropriate Cable Outer Diameter (mm) | Identifying Mark | Part Number |
|-----------------------------|---------------------------------------|------------------|-------------|
| G1/2                        | 8 -10                                 | 16 8-10          | G9601AM     |
|                             | 10.1-12                               | 16 10-12         |             |

T0501.EPS

Follow the procedure below to install the flameproof packing adapter.

- Screw the flameproof packing adapter into the terminal box until the O-ring touches the terminal box wiring port (at least 6 full turns), and tighten the lock nut.
- Insert the cable through the union cover, the union coupling, the gland the clamp nut, the clamp ring, one washer, the rubber packing, and the packing box, in that order.
- Insert the end of the cable into the terminal box.
- Tighten the union cover to grip the cable. When tightening the union cover, tighten approximately one turn past the point where the cable will no longer move up and down. Proper tightening is important. If it is too tight, a circuit break in the cable may occur; if not tight enough, the flameproof effectiveness will be compromised.

#### ⚠ CAUTION

Tighten the union cover approximately one turn after the point where you can no longer shift the cable up and down by hand. Take great care in this step, since proper tightening is very important.

- Fasten the cable with tightening the clamp nut.
- Tighten the lock nut on the union cover.
- Connect the cable wires to each terminal.

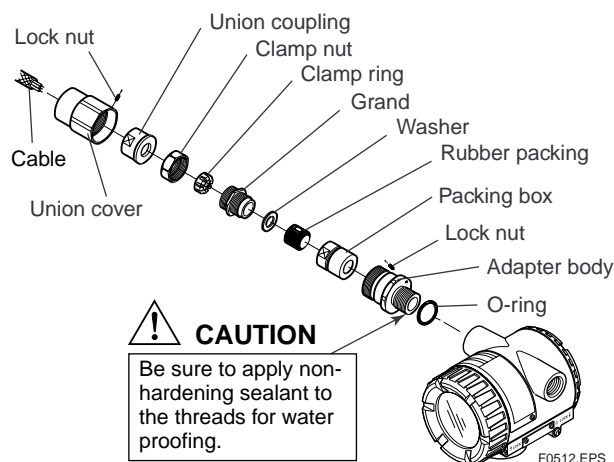
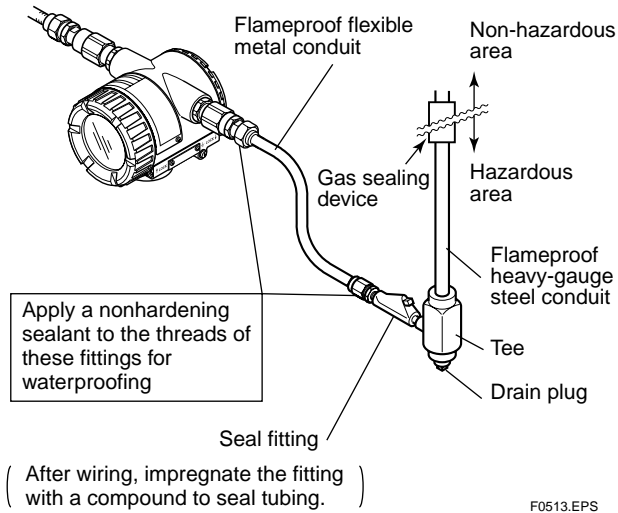

Figure 5.12 Flameproof Gland Packing Adapter Installation

### ■ Flameproof metal conduit wiring

- A seal fitting must be installed near the terminal box connection port for a sealed construction.
- Apply a nonhardening sealant to the threads of the terminal box connection port, flexible metal conduit and seal fitting for waterproofing.



F0513.EPS

**Figure 5.13 Typical Wiring Using Flameproof Metal Conduit**

## 5.6 Grounding

Grounding is always required for the proper operation of transmitters. Follow the domestic electrical requirements as regulated in each country. For a transmitter with built-in lightning protector, grounding should satisfy ground resistance of  $10\Omega$  or less.

Ground terminals are located on the inside and outside of the terminal box. Either of these terminals may be used.



### WARNING

For TIIS flameproof type and intrinsically safe, grounding should satisfy Class D requirements (grounding resistance,  $100\Omega$  or less).

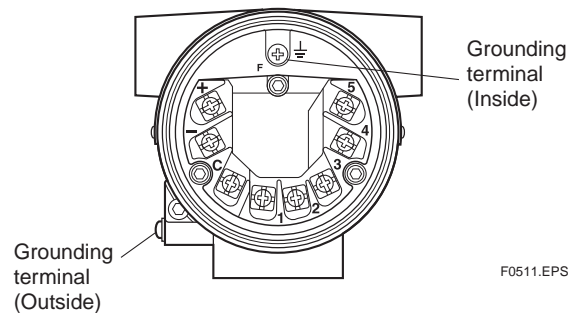

F0511.EPS

**Figure 5.14 Grounding Terminal**

# 6. MAINTENANCE

## 6.1 General

Each component of this instrument is configured in units to make maintenance easier.

This chapter contains disassembly and assembly procedures associated with calibration, adjustment and part replacement required for maintenance of the affected instrument.



### IMPORTANT

- Maintenance of this instrument should be performed in a service shop where the necessary tools are provided.
- Handling the CPU assembly  
Some of the parts contained in the CPU assembly are susceptible to static electricity damage. Before performing maintenance, use a ground wrist band or other antistatic measures, and avoid touching the electronic components and circuits with bare hands. When removed from the instrument, keep the CPU assembly in an antistatic bag.

## 6.2 Calibration

This instrument is fully factory-tested and is guaranteed for the intended accuracy, eliminating the need for calibration. When calibration needs to be verified, the following equipment and calibration procedure is recommended.

### 6.2.1 Selection of Equipment for Calibration

Table 6.1 lists the equipment required for calibration. The calibration equipment traceable to a verifying agency standard should be used.

### 6.2.2 Calibration Procedure

To conduct calibration required to evaluate the uncertainty while using the instrument, follow the steps below:

- In accordance with the example wiring shown in Figure 6.1, connect each equipment and initiate warm up. Lay wiring on the input side according to the sensor to be used.

Table 6.1 Calibration Equipment List

| Name                 | Recommended  | Remark  |
|----------------------|--|---|
| Power supply         | SDBT, SDBS type distributor  | 4 to 20mA DC (Output voltage: $26.5 \pm 1.5V$ , drop by internal $250\Omega$ resistance included) |
| Load resistance      | 2792 type standard resistor ( $250\Omega \pm 0.005\%$ )                      | For 4 to 20mA DC  |
| Voltmeter            | Model 1271 digital multimeter (accuracy: $\pm 0.002\%$ )                     | For 4 to 20mA DC signal   |
| Universal calibrator | Model 9100 type  | For calibration of DC voltage and thermocouple  |
| Variable resistor    | 279301 type 6-dial variable resistor (accuracy: $\pm 0.001\% \pm 2m\Omega$ ) | For calibration of thermometer resistor (RTD) input   |

T0601.EPS

#### a. Wiring of power supply and output

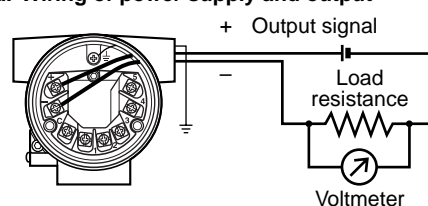

#### b. Example of wiring for thermocouple or DC voltage input (when 1 input type is used)

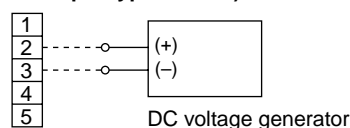

#### c. Example of wiring for thermometer resistor 4-core type (when 1 input type is used)

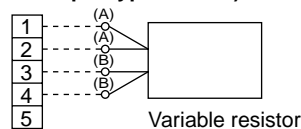

F0601.EPS

Figure 6.1 Example of Wiring for Calibration Equipment

- For DC voltage input  
With a voltage generator, deliver input signals corresponding to 0, 25, 75, or 100% of the input span to the temperature transmitter. Measure the resulting input signal with the voltmeter (digital multimeter) and check the output value relative to the input value.

## 3. For thermocouple input

Since this instrument is equipped with a reference junction compensating function, use a reference junction compensating function in universal calibrator in order to compensate for this function upon calibration. According to the reference millivolt table for thermocouple, obtain millivolt corresponding to 0, 25, 50, 75, or 100% of the span, and use that power as the input value, then deliver it from the universal calibrator to the temperature transmitter. Measure the resulting output signal with the voltage meter (digital multimeter) and check the output value relative to the input value.

## 4. Thermometer resistor (RTD)

Using a thermometer resistor as input, calibration of the temperature transmitter is carried out via a 4-core wire connection.

As defined the reference resistor value table of the thermometer resistor (RTD), obtain resistance values corresponding to 0, 25, 50, 75 or 100% of the span, and use the obtained resistance as the input value, then deliver it to the temperature transmitter by means of a variable resistor. Measure the resulting output signal with the voltmeter (digital multimeter) and check the output value relative to the input value.

## 5. In Steps 2 through 4, if the output signal deviates from the given range of accuracy when a given input signal is delivered, adjust the output using the handheld terminal. For details of how to adjust the output, refer to the additional references, "BRAIN Protocol" IM 01C50T03-01E or "HART Protocol" IM 01C50T01-01E and the instruction manual for each terminal.

## 6.3 Disassembly and Assembly

This section details the procedure for part replacement or disassembly and assembly of each component depending on the maintenance process.

Before starting disassembly and assembly work, turn off the power, and use a tool suited to the associated work.

Table 6.2 lists the tools required for disassembly and assembly of the instrument.

**Table 6.2 Tools for Disassembly and Assembly**

| Tool name            | Quantity | Remark        |
|----------------------|----------|---------------|
| Phillips screwdriver | 1        |               |
| Standard screwdriver | 1        |               |
| Hexagonal wrench     | 1        |               |
| Crescent wrench      | 1        |               |
| Torque wrench        | 1        |               |
| Box wrench           | 1        | For M10 screw |
| Box screwdriver      | 1        |               |
| Forceps              | 1        |               |

T0602.EPS



### CAUTION

#### Precautions for CENELEC, SAA and TIIS Flameproof Type Transmitters

- For a withstand flameproof type transmitter, as a rule, move the transmitter to a non-hazardous location, then proceed with maintenance and restore the instrument to the original condition.
- For a withstand CENELEC, SAA and TIIS flameproof type transmitter, turn the lock bolt (hexagon socket bolt) clockwise with a wrench for hexagon head, unlock and remove the cover. When installing the cover, it is the must to turn the lock bolt counterclockwise and lock the cover (locked to a torque of 0.7 Nm).
- For a withstand flameproof type transmitter, in no case should the user be allowed to modify the transmitter. Therefore, no user is allowed to add a built-in indicator, or use the transmitter with the indicator removed. Contact us for any modification.

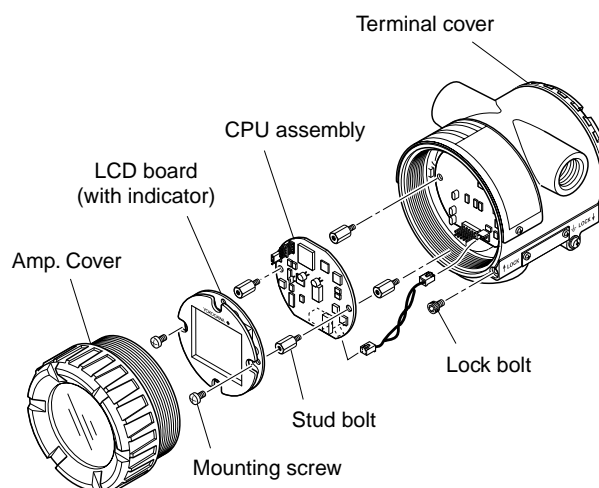

F0602.EPS

**Figure 6.3 Mounting and Removal of Built-in Indicator and CPU Assembly**

### 6.3.1 Replacement of Built-in Indicator

#### ■ Removal of built-in indicator

1. Remove the cover.
2. Loosen two mounting screws while using your hand to support the built-in indicator.
3. Remove the LCD assembly from the CPU assembly. At this time, straighten and pull the LCD assembly forward so that the connector connecting the CPU assembly and the LCD assembly is not damaged.

#### ■ Mounting the built-in indicator

Integral Indicator can be installed in the following three directions.

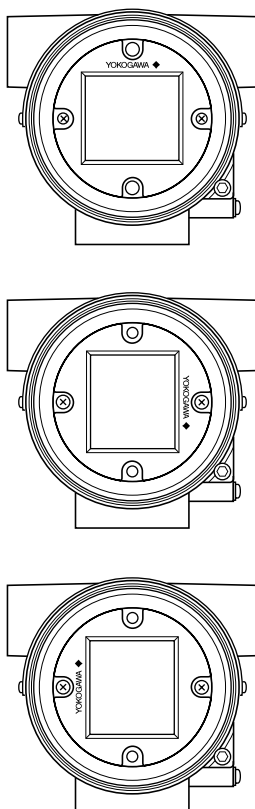

F0603.EPS

Figure 6.4 Installation Direction of Indicator

1. Place the LCD assembly in desired direction over the CPU assembly.
2. Align the mounting hole of the LCD assembly with the stud bolt hole, and carefully insert the indicator into the connector in a straight manner so that the connector is not damaged.
3. Tighten the two mounting screws that secure the indicator.
4. Install the cover.

### 6.3.2 Replacement of CPU Assembly

#### ■ Removal of CPU assembly

1. Remove the cover.
2. Use a Phillips screwdriver to loosen the two screws.
3. For a CPU assembly with a built-in indicator, remove it as described in Section 6.3.1. Next loosen the two stud bolts.
4. Pull the CPU assembly directly toward you.
5. Remove the cable (with a brown connector attached at the head).



#### NOTE

Use care not to apply excessive force to the CPU assembly during removal.

#### ■ Mounting the CPU assembly

1. Connect the cable with the CPU assembly.
2. Align the pin on the base board with the connector (black) of the CPU assembly, and insert the CPU assembly straight into the board.



#### IMPORTANT

Use care not to pinch the cable under the cover, and fully insert the cable into the case.

3. Loosen the two screws. If the unit includes a built-in indicator, install it as described in Section 6.3.1.
4. Mount the cover.

## 6.4 Troubleshooting

When the measured value is found abnormal, follow the troubleshooting flowchart below. If the complex nature of the trouble means that the cause cannot be identified using the following flowchart, refer the matter to our service personnel.

### 6.4.1 Basic Troubleshooting Flow

When the process measurement is found to be abnormal, it is necessary to determine whether the input temperature is out of range, the sensor has failed or being damaged, or the unit has been improperly wired. If it is suspected that the measurement system is the source of the problem, use the flowchart to identify the affected area and determine how to proceed.

In these troubleshooting steps, the self diagnostic function provides helpful solutions to the problem, refer to the instructions in Section 6.5 for details.

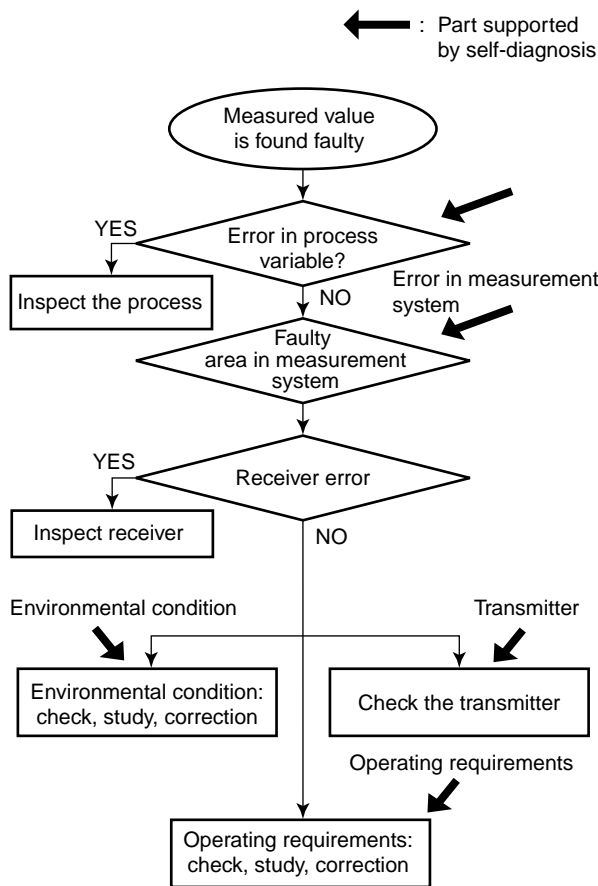
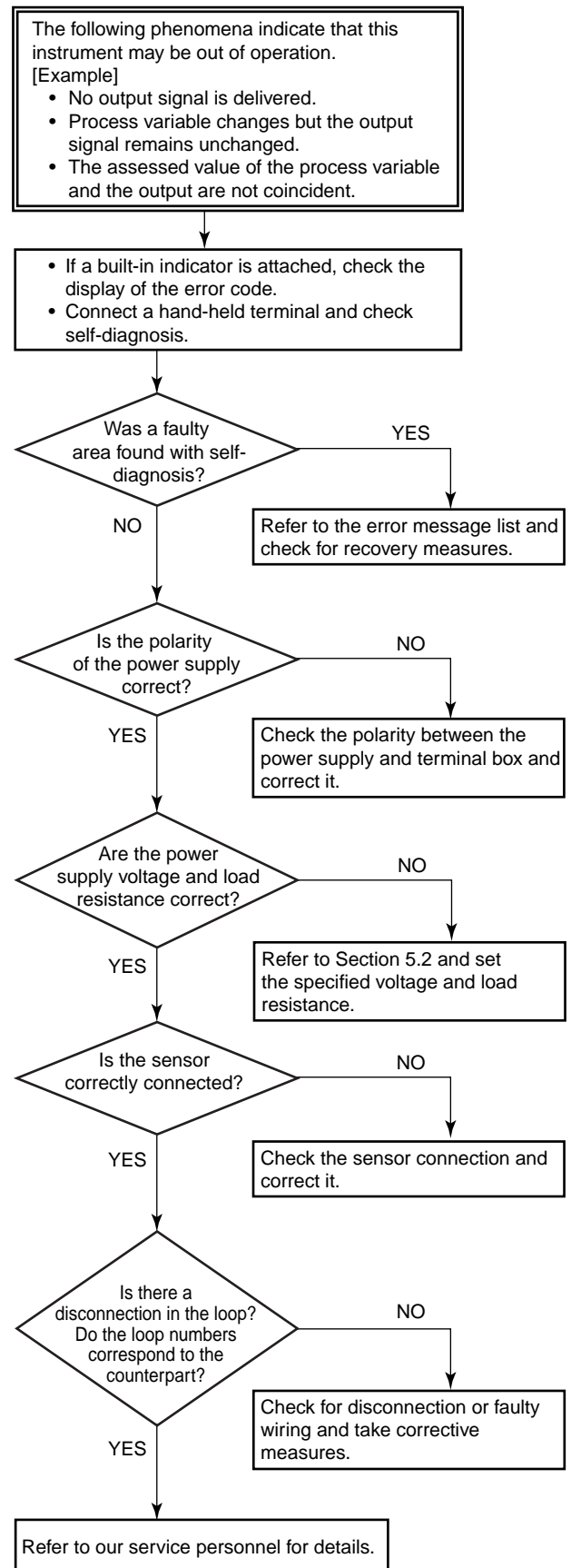

Figure 6.5 Basic Flow and Self-diagnosis

F0604.EPS

### 6.4.2 Example of Troubleshooting Flow



F0605.EPS

Figure 6.6 Example of Troubleshooting Flow

Table 6.3 Problems, Causes and Countermeasures

| Observed Problems                              | Possible Cause                                       | Countermeasure  | Related Parameter                    |  |
|--|--|---|--------------------------------------|--|
|  |  |   | (BRAIN protocol)                     | (HART protocol)                                    |
| Output fluctuates greatly.                     | Span is too narrow.                                  | Check the range, and change the settings to make the span larger.   | F10:LRV<br>F20:URV                   | PV LRV (4)<br>PV URV (5)                           |
|  | Input adjustment by user was not correctly done.     | Clear the user adjustment (Sensor trim) value or set it to off.   | J05:SNSR1 CLR<br>K05:SNSR2 CLR       | Snsr1 Trim Act (123312)<br>Snsr2 Trim Act (123322) |
|  | Output adjustment by user was not correctly done.    | Clear the user adjustment (output trim) value or set it to off.   | L05:OUT CLR                          | D/A Clr to Default (12343)                         |
| Transmitter outputs fixed current.             | The transmitter is in manual (test output) mode.     | Release manual mode. (Make the transmitter return to Automatic Mode)  | G10:OUTPUT MODE                      | Loop test (122)                                    |
|  | Input adjustment by user was not correctly done.     | Clear the user adjustment (Sensor trim) value or set it to off.   | J05:SNSR1 CLR<br>K05:SNSR2 CLR       | Snsr1 Trim Act (123312)<br>Snsr2 Trim Act (123322) |
|  | Output adjustment by user was not correctly done.    | Clear the user adjustment (output trim) value or set it to off.   | L05:OUT CLR                          | D/A Clr to Default (12343)                         |
| Output is reversed. (See note 1)               | LRV is greater than URV.                             | Set the correct value to URV and LRV.   | F10:LRV<br>F20:URV                   | PV LRV (4)<br>PV URV (5)                           |
|  | The transmitter is set to reversed output mode.      | Set the transmitter to normal output mode.  | H10:REVERSE OUT                      | —  |
| Parameters cannot be changed.                  | The transmitter is in write protect status.          | Release write protect.  | H40:WRITE PROTCT                     | Chng wrt Protect (Hot key)                         |
| Sensor backup function doesn't work correctly. | Settings of Process Variables are not correct.       | Set Sensor1 as PV and Sensor2 as SV.  | B10:PV is<br>B20:SV is               | PV is (11211)<br>SV is (11212)                     |
|  | Configuration of Sensor1 and Sensor2 is not correct. | <ul style="list-style-type: none"> <li>Check the type and wire settings for Sensor1 and Sensor2.</li> <li>Check the connection of Sensor1 and Sensor2.</li> </ul> | D10:SENSOR1 TYPE<br>E10:SENSOR2 TYPE | Snsr1 config (134)<br>Snsr2 config (135)           |
|  | Sensor Burnout is set to "off."                      | Check the Sensor Burnout setting.   | F40:BURN OUT                         | Sensor barnout (14315)                             |
|  | Sensor backup mode is not enabled.                   | Change the Sensor Backup function to "enable."  | H20:SNSR BACKUP                      | Snsr backup (14141)                                |
| Output damping doesn't work.                   | Damping time constant is set to "0 second."          | Set correct value.  | B12:PV DAMPING                       | PV damp (1322)                                     |
|  | Setting for "PV damping point" is too small.         | If output fluctuation is great, set a greater value for PV damping point than current setting. (Initial setting is "2%" of output)                                | B13:DMP POINT                        | PV damp point (1323)                               |

T0603.EPS

Note 1: If the reversed output is desired and necessary setting was done by user, it is not considered as a problem.



## 6.5 Integral Indicator and Error Display

For temperature transmitters equipped with an integral indicator, errors in the temperature sensor or the transmitter cause an integral indicator to call up the applicable error code. Table 6.4 lists the error codes and the associated corrective actions.

**Table 6.4 List of Error Codes**

| Indicator | BT200 display                  | Cause  | Output operation upon error  | Action  |
|-----------|--------------------------------|--|--|---|
| N/A       | Good                           |  |  |   |
| Er-01     | Output Too Low                 | Input value is lower than the PV low range value.  | Output goes to minimum value(-2.0%).   | Check the LRV setting and adjust.   |
| Er-02     | Output Too High                | Input value is higher than the PV upper range value.   | Output goes to maximum value(105%).  | Check the URV setting and adjust.   |
| Er-03     | Sensor1 Failure                | Sensor1 fails or disconnects from the terminal block.  | If sensor1 is set as PV, the burnout value is output. When sensor backup mode is set in YTA320, sensor2 input is used as output. | <ul style="list-style-type: none"> <li>• Check sensor for damage.</li> <li>• Check terminal connection.</li> <li>• If sensor backup mode is set, refer to "Er-09".</li> </ul>                         |
| Er-04     | Sensor2 Failure (YTA320 only)  | Sensor2 fails or disconnects from the terminal block.  | If sensor2 is set as PV, or sensor backup mode is in effect, sensor burnout value is output.                                     | <ul style="list-style-type: none"> <li>• Check sensor for damage.</li> <li>• Check terminal connection.</li> <li>• If sensor backup mode is set, repair wiring or replace damaged sensors.</li> </ul> |
| Er-05     | S1 Signal Error                | Sensor1 input value greatly exceeds the sensor measurement range. Sensor type setting or connection polarity may be incorrect. | Output goes to minimum value(-2.0%) or maximum value(105%).  | <ul style="list-style-type: none"> <li>• Check sensor connections.</li> <li>• Check the sensor type selected.</li> </ul>  |
| Er-06     | S2 Signal Error (YTA320 only)  | Sensor2 input value greatly exceeds sensor measurement range. Sensor type setting or connection polarity may be incorrect.     | Output goes to minimum value(-2.0%) or maximum value(105%).  | <ul style="list-style-type: none"> <li>• Check sensor connections.</li> <li>• Check sensor type selected.</li> </ul>  |
| Er-07     | Amb Temp Low                   | The ambient temperature exceeds the lower ambient temp limit and the specified accuracy cannot be achieved.                    | Continues to operate and output.   | Use a heater to raise the ambient temperature, or reset to a higher level.  |
| Er-08     | Amb Temp High                  | The ambient temperature exceeds the upper ambient temp limit and the specified accuracy cannot be achieved.                    | Continues to operate and output.   | Take enough distance from the source of heat, or reset to a lower level.  |
| Er-09     | Sns Backup Start (YTA320 only) | Sensor backup mode is in effect.   | Sensor2 input is used as output. If sensor2 also fails, the transmitter operate with burnout settings.                           | Restore the status of sensor1 to normal and Enable sensor1 return parameters, or turn the power ON again.   |
| Er-10     | Illegal PV MAP                 | There is a problem with the PV mapping settings.   | Output status immediately before error is retained (HOLD).   | Check the setting for PV mapping and correct the setting.   |
| Er-11     | Term Sns Failure               | Terminal block temperature sensor failed.  | Operation and output continues.  | Contact our service personnel.  |
| Er-12     | EEPROM Failure                 | EEPROM failed.   | The output goes to the value set by the hardware failure mode jumper.  | Contact our service personnel.  |
| Er-13     | CPU Failure                    | Output side hardware failure.  | The output goes to the value set by the hardware failure mode jumper.  | Contact our service personnel.  |
| Er-14     | AD Conv Failure                | Input circuit hardware failure.  | The output goes to the value set by the hardware failure mode jumper.  | Contact our service personnel.  |
| Er-15     | Reverse Cal Fail               | Confirmation Calculation result is bad.  | The output goes to the value set by the hardware failure mode jumper.  | Contact our service personnel.  |

T0604.EPS

# 7. GENERAL SPECIFICATIONS

## 7.1 Standard Specifications

For the specifications of Fieldbus communication type marked with (◇), refer to IM 01C50T02-01E.

### Input signal:

|                             |  |
|-----------------------------|--|
| Input points:               | YTA110; 1, YTA310; 1, YTA320; 2  |
| Thermocouple: (T/C)         | J, K, E, T, R, S, B, N (JIS/IEC584), L, U (DIN43710), W3, W5 (ASTM988) |
| Thermometer resistor: (RTD) | Pt100, Pt200, Pt500 (IEC751), JPt100(JIS), Cu, Ni120 2/3/4-wire        |
| DC voltage:                 | mV   |
| Resistance:                 | Resistor 2/3-wire  |

### Input signal source resistance:

1k $\Omega$  or lower (at thermocouple, DC voltage input)

### Input lead wire resistance:

10 $\Omega$ /1-core or less (with thermometer resistor, resistance input)

### Output(◇):

Two wire 4 to 20 mA DC  
Output range: 3.68 mA to 20.8 mA

### Measuring range:

Refer to Table 7.1.

### Power supply voltage(◇):

For general use type;  
10.5 to 42 VDC  
With lightning protection (Optional code A);  
10.5 to 32 VDC  
For intrinsically safe, Type n, non-incendive or non-sparking type;  
10.5 to 30 VDC

### Communication line conditions(◇):

Power supply voltage; 16.4 to 42 VDC  
Load resistance; 250 to 600 $\Omega$  (including cable resistance)  
For relation between power supply voltage and load resistance, refer to Figure 5.3.  
Maximum line length; 2 km when CEV cable is used.  
Load resistance; 0.22  $\mu$ F or less  
Load inductance; 3.3 mH or less

Spacing to power line;

Output signal line; 15 cm or longer (avoid parallel wiring)

Input signal line; 100 cm or longer (avoid parallel wiring)

Input impedance of receiver connected to receiver resistance; 10 k $\Omega$  or higher (at 2.4 kHz)

### Accuracy(◇):

YTA110;  
A/C conversion accuracy + D/A conversion accuracy (Refer to Table 7.1) or  $\pm 0.1\%$ , whichever is greater. For thermocouple input, above plus reference junction compensation accuracy.  
YTA310, YTA320;  
A/C conversion accuracy + D/A conversion accuracy (Refer to Table 7.1) For thermocouple input, above plus reference junction compensation accuracy.

### Reference junction compensation accuracy:

$\pm 0.5^{\circ}\text{C}$  ( $\pm 0.9^{\circ}\text{F}$ )

### Ambient temperature:

$-40$  to  $85^{\circ}\text{C}$  ( $-40$  to  $185^{\circ}\text{F}$ ) . . . general type  
 $-30$  to  $80^{\circ}\text{C}$  ( $-1$  to  $176^{\circ}\text{F}$ ) . . . . with Integral indicator

### Ambient temperature effect per 10 $^{\circ}\text{C}$ change(◇) :

YTA110;  
 $\pm 0.1\%$  or  $\pm$  (Temperature Coefficient/span), whichever is greater (refer to Table 7.2)  
YTA310, YTA320;  
A/D conversion temperature factor + D/A conversion temperature factor (refer to Table 7.3)

### Stability

RTD:  
 $\pm 0.1\%$  of reading or  $\pm 0.1^{\circ}\text{C}$  per 2 years, whichever is greater at  $23 \pm 2^{\circ}\text{C}$ .

T/C:  
 $\pm 0.1\%$  of reading or  $\pm 0.1^{\circ}\text{C}$  per year, whichever is greater at  $23 \pm 2^{\circ}\text{C}$ .

### 5 Year Stability

RTD:  
 $\pm 0.2\%$  of reading or  $\pm 0.2^{\circ}\text{C}$ , whichever is greater at  $23 \pm 2^{\circ}\text{C}$ .

T/C:  
 $\pm 0.4\%$  of reading or  $\pm 0.4^{\circ}\text{C}$ , whichever is greater at  $23 \pm 2^{\circ}\text{C}$ .

**Ambient humidity:**

5 to 100%RH at 40°C (104°F)

**Effect of supply voltage fluctuation:**

±0.005%/V

**Insulation:**

Input/output insulated at 500 V DC

**Mounting:**

Mounted on 2B pipes and wall

**Degrees of Protection:**

IP67, NEMA 4X, JIS C0920 immersion proof

**Electrical connection:**

Refer to "Model and Specification Codes".

**Case and cover:**

Aluminum alloy casting

**Painting:**

Polyurethane resin baked finish

Deep sea moss green (equivalent of Munsell  
0.6GY3.1/2.0)

**Integral indicator (option):**

LCD digital indicator (5-digit display)

Output bar graph; 0 to 100% display

**Damping constant:**

0 to 99 seconds (integer range that can be set)

**Sensor burnout (Output Signal Code D&E) :**

High (110%, 21.6 mA DC) or Low (-2.5%, 3.6  
mA DC)

**Weight:**

1.2 kg; without built-in indicator (without mount-  
ing bracket)

1.4 kg; with Integral indicator (without mounting  
bracket)

**EMC compliant standard: CE , N200**

EN61326, AS/NZS CISPR11

Table 7.1 Input Type, Measurement Range and Accuracy

| Sensor Type | Reference Standard | Measurement Range |              | Minimum Span (Recommended) | Accuracy      |              |              |        | D/A Accuracy |
|-------------|--------------------|-------------------|--------------|----------------------------|---------------|--------------|--------------|--------|--------------|
|             |                    | °C                | °F           |                            | Input range   |              | A/D Accuracy |        |              |
|             |                    |                   |              |                            | °C            | °F           | °C           | °F     |              |
| T/C         | IEC584             | B                 | 100 to 1820  | 212 to 3308                | 25 °C (45 °F) | 100 to 300   | 212 to 572   | ± 3.0  | ± 5.4        |
|             |                    |                   |              |                            |               | 300 to 400   | 572 to 752   | ± 1.0  | ± 1.8        |
|             |                    | 400 to 1820       | 752 to 3308  | ± 0.75                     |               | ± 1.35       |              |        |              |
|             |                    | E                 | -200 to 1000 | -328 to 1832               |               | -200 to -50  | -328 to -58  | ± 0.35 | ± 0.63       |
|             |                    |                   |              |                            |               | -50 to 1000  | -58 to 1832  | ± 0.16 | ± 0.29       |
|             |                    | J                 | -200 to 1200 | -328 to 2192               |               | -200 to -50  | -328 to -58  | ± 0.40 | ± 0.72       |
|             |                    |                   |              |                            |               | -50 to 1200  | -58 to 2192  | ± 0.20 | ± 0.36       |
|             |                    | K                 | -200 to 1372 | -328 to 2502               |               | -200 to -50  | -328 to -58  | ± 0.50 | ± 0.90       |
|             |                    |                   |              |                            |               | -50 to 1372  | -58 to 2502  | ± 0.25 | ± 0.45       |
|             |                    | N                 | -200 to 1300 | -328 to 2372               |               | -200 to -50  | -328 to -58  | ± 0.80 | ± 1.44       |
|             | -50 to 1300        |                   |              |                            | -58 to 2372   | ± 0.35       | ± 0.63       |        |              |
|             | R                  | -50 to 1768       | -58 to 3214  | -50 to 0                   | -58 to 32     | ± 1.0        | ± 1.8        |        |              |
|             |                    |                   |              | 0 to 100                   | 32 to 212     | ± 0.80       | ± 1.44       |        |              |
|             |                    |                   |              | 100 to 600                 | 212 to 1112   | ± 0.60       | ± 1.08       |        |              |
| 600 to 1768 |                    |                   |              | 1112 to 3214               | ± 0.40        | ± 0.72       |              |        |              |
| S           | -50 to 1768        | -58 to 3214       | -50 to 0     | -58 to 32                  | ± 1.0         | ± 1.8        |              |        |              |
|             |                    |                   | 0 to 100     | 32 to 212                  | ± 0.80        | ± 1.44       |              |        |              |
|             |                    |                   | 100 to 600   | 212 to 1112                | ± 0.60        | ± 1.08       |              |        |              |
|             |                    |                   | 600 to 1768  | 1112 to 3214               | ± 0.40        | ± 0.72       |              |        |              |
| T           | -200 to 400        | -328 to 752       | -200 to -50  | -328 to -58                | ± 0.25        | ± 0.45       |              |        |              |
|             |                    |                   | -50 to 400   | -58 to 752                 | ± 0.14        | ± 0.25       |              |        |              |
| W3          | 0 to 2300          | 32 to 4172        | 0 to 400     | 32 to 752                  | ± 0.80        | ± 1.44       |              |        |              |
|             |                    |                   | 400 to 1400  | 752 to 2552                | ± 0.50        | ± 0.90       |              |        |              |
|             |                    |                   | 1400 to 2000 | 2552 to 3632               | ± 0.60        | ± 1.08       |              |        |              |
|             |                    |                   | 2000 to 2300 | 3632 to 4172               | ± 0.90        | ± 1.62       |              |        |              |
| W5          | 0 to 2300          | 32 to 4172        | 0 to 400     | 32 to 752                  | ± 0.70        | ± 1.26       |              |        |              |
|             |                    |                   | 400 to 1400  | 752 to 2552                | ± 0.50        | ± 0.90       |              |        |              |
|             |                    |                   | 1400 to 2000 | 2552 to 3632               | ± 0.70        | ± 1.26       |              |        |              |
|             |                    |                   | 2000 to 2300 | 3632 to 4172               | ± 0.90        | ± 1.62       |              |        |              |
| L           | -200 to 900        | -328 to 1652      | -200 to -50  | -328 to -58                | ± 0.30        | ± 0.54       |              |        |              |
|             |                    |                   | -50 to 900   | -58 to 1652                | ± 0.20        | ± 0.36       |              |        |              |
| U           | -200 to 600        | -328 to 1112      | -200 to -50  | -328 to -58                | ± 0.50        | ± 0.90       |              |        |              |
|             |                    |                   | -50 to 600   | -58 to 1112                | ± 0.25        | ± 0.45       |              |        |              |
| RTD         | IEC751             | Pt100             | -200 to 850  | -328 to 1562               | 10 °C (18 °F) | -200 to 850  | -328 to 1562 | ± 0.14 | ± 0.25       |
|             |                    | Pt200             | -200 to 850  | -328 to 1562               | -200 to 850   | -328 to 1562 | ± 0.30       | ± 0.54 |              |
|             |                    | Pt500             | -200 to 850  | -328 to 1562               | -200 to 850   | -328 to 1562 | ± 0.20       | ± 0.36 |              |
|             | JIS C1604          | JPt100            | -200 to 500  | -328 to 932                | -200 to 500   | -328 to 932  | ± 0.16       | ± 0.29 |              |
|             |                    | Cu                | -70 to 150   | -94 to 302                 | -70 to -40    | -94 to -40   | ± 1.35       | ± 2.43 |              |
|             | Ni120              | —                 | -70 to 320   | -94 to 608                 | -40 to 150    | -40 to 302   | ± 1.0        | ± 1.8  |              |
| mV          | —                  | -10 to 100 [mV]   |              | 3 [mV]                     | —             | ± 12 [µV]    |              |        |              |
| ohm         | —                  | 0 to 2000 [Ω]     |              | 20 [Ω]                     | —             | ± 0.35 [Ω]   |              |        |              |

T0701.EPS

Table 7.2 YTA110 Effect of Ambient Temperature

| Sensor Type                       | Temperature Coefficient         |
|-----------------------------------|---------------------------------|
| Thermocouples E, J, K, N, T, L, U | 0.08°C + 0.02% of abs.reading   |
| Thermocouples R, S, W3, W5        | 0.25°C + 0.02% of abs.reading   |
| T/C B                             | 100°C ≤ Reading < 300°C         |
|                                   | 300°C ≤ Reading                 |
| RTD                               | 1°C + 0.02% of abs.reading      |
| mV                                | 0.08°C + 0.02% of abs.reading   |
| mV                                | 0.002 mV + 0.02% of abs.reading |
| ohm                               | 0.1 Ω + 0.02% of abs.reading    |

T07021.EPS

Note1: Ambient Temperature Effect per 10°C change is ±0.1% or ± (temperature coefficient/span), whichever is greater.

Note2: The "abs.reading" on Table7.2 means the absolute value of the reading in °C.

Example of abs reading;

When the temperature value is 250 Kelvin, abs reading is 23.15, absolute (250–273.15).

Example of Ambient Temperature Effect;

Conditions;

- 1) Input Sensor:Pt100
- 2) Calibration Range:– 100 to 100°C
- 3) Reading value: –50°C

Ambient Temperature Effect per 10°C;

Temperature Coefficient/Span

$$=(0.08°C+0.02/100×|-50°C|)/\{100°C-(-100°C)\}= 0.00045$$

$$\rightarrow 0.045\%$$

Therefore, Ambient Temperature Effect is ±0.1%/10°C

Table 7.3 YTA310, YTA320 Effect of Ambient Temperature

| Sensor Type |              | Input Range  |                                       | A/D Coefficient                       | D/A Coefficient                                 |
|-------------|--------------|--------------|---------------------------------------|---------------------------------------|---|
|             |              | °C           | °F                                    |                                       |   |
| T/C         | B            | 100 to 300   | 212 to 572                            | ± (0.530 °C - 0.080 % of reading)     | ± {0.0088% of span + 0.007% of (reading - LRV)} |
|             |              | 300 to 1000  | 572 to 1832                           | ± (0.350 °C - 0.021 % of reading)     |   |
|             |              | 1000 to 1820 | 1832 to 3308                          | ± (0.140 °C)                          |   |
|             | E            | -200 to 1000 | -328 to 1832                          | ± (0.035 °C + 0.042 % of abs.reading) |   |
|             | J            | -200 to 0    | -328 to 32                            | ± (0.039 °C + 0.020 % of abs.reading) |   |
|             |              | 0 to 1200    | 32 to 2192                            | ± (0.039 °C + 0.0029 % of reading)    |   |
|             | K            | -200 to 0    | -328 to 32                            | ± (0.046 °C + 0.020 % of abs.reading) |   |
|             |              | 0 to 1372    | 32 to 2502                            | ± (0.046 °C + 0.0054 % of reading)    |   |
|             | N            | -200 to 0    | -328 to 32                            | ± (0.054 °C + 0.010 % of abs.reading) |   |
|             |              | 0 to 1300    | 32 to 2372                            | ± (0.054 °C + 0.0036 % of reading)    |   |
|             | R            | -50 to 200   | -58 to 392                            | ± (0.210 °C - 0.032 % of abs.reading) |   |
|             |              | 200 to 1768  | 392 to 3214                           | ± (0.150 °C)                          |   |
|             | S            | -50 to 200   | -58 to 392                            | ± (0.210 °C - 0.032 % of abs.reading) |   |
|             |              | 200 to 1768  | 392 to 3214                           | ± (0.150 °C)                          |   |
| T           | -200 to 0    | -328 to 32   | ± (0.046 °C - 0.036 % of abs.reading) |                                       |   |
|             | 0 to 400     | 32 to 752    | ± (0.046 °C)                          |                                       |   |
| W3          | 0 to 1400    | 32 to 2552   | ± (0.100 °C + 0.0040 % of reading)    |                                       |   |
|             | 1400 to 2300 | 2552 to 4172 | ± (-0.130 °C + 0.020 % of reading)    |                                       |   |
| W5          | 0 to 1400    | 32 to 2552   | ± (0.100 °C + 0.0040 % of reading)    |                                       |   |
|             | 1400 to 2300 | 2552 to 4172 | ± (-0.120 °C + 0.020 % of reading)    |                                       |   |
| L           | -200 to 0    | -328 to 32   | ± (0.039 °C + 0.020 % of abs.reading) |                                       |   |
|             | 0 to 900     | 32 to 1652   | ± (0.039 °C + 0.0029 % of reading)    |                                       |   |
| U           | -200 to 0    | -328 to 32   | ± (0.046 °C + 0.036 % of abs.reading) |                                       |   |
|             | 0 to 600     | 32 to 1112   | ± (0.046 °C)                          |                                       |   |
| RTD         | Pt100        | -200 to 850  | -328 to 1562                          | ± (0.047 °C + 0.009 % of reading)     |   |
|             | Pt200        | -200 to 850  | -328 to 1562                          | ± (0.065 °C + 0.012 % of reading)     |   |
|             | Pt500        | -200 to 850  | -328 to 1562                          | ± (0.047 °C + 0.009 % of reading)     |   |
|             | JPt100       | -200 to 500  | -328 to 932                           | ± (0.047 °C + 0.009 % of reading)     |   |
|             | Cu           | -70 to 150   | -94 to 302                            | ± (0.320 °C + 0.120 % of reading)     |   |
|             | Ni120        | -70 to 320   | -94 to 608                            | ± (0.016 °C + 0.007 % of reading)     |   |
| mV          |              | —            |                                       | ± (0.001mV + 0.0043 % of abs.reading) |   |
| ohm         |              | —            |                                       | ± (0.040 Ω + 0.0088 % of reading)     |   |

T07022.EPS

Note: Temperature Effect = A/D coefficient + D/A coefficient (The data in the table is the coefficient per 10°C change.)

Example 1; Pt100Ω, 0 to 200°C calibration range, 50°C reading  
 $(0.047\text{ °C} + 50\text{ °C} \times 0.009\%) + [200\text{ °C} \times 0.0088\% + (50 - 0) \times 0.007\%]$   
 $= (0.047\text{ °C} + 0.0045\text{ °C}) + (0.0176\text{ °C} + 0.0035\text{ °C})$   
 $= \pm 0.0726\text{ °C}$  [ per 10°C change ]

Example 2; T T/C, -100 to 100°C calibration range, 250°C reading  
 $(0.046\text{ °C} + |250\text{ °C}| \times 0.036\%) + \{200\text{ °C} \times 0.0088\% + [250 - (-100)] \times 0.007\%$   
 $= (0.046\text{ °C} + 0.018\text{ °C}) + (0.0176\text{ °C} + 0.0035\text{ °C})$   
 $= \pm 0.0851\text{ °C}$  [ per 10°C change ]

**Terminals**

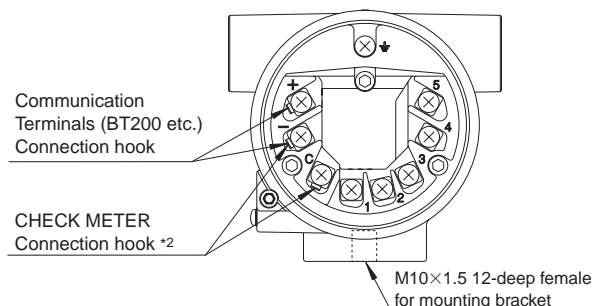

**Terminal Configuration**

|   |  |
|---|--|
| + | Power Supply and output terminal         |
| - | External Indicator (ammeter) terminal *2 |
| C | External Indicator (ammeter) terminal *2 |
| ⊥ | Ground terminal                          |

\*2: When using an external indicator or check meter, the internal resistance must be 10Ω or less. The hook is not available for Fieldbus communication type(output signal code F).

F0702.EPS

## Factory setting (◇)

|                                  |   |
|----------------------------------|---|
| Tag No.                          | Left blank if not specified in order      |
| Input sensor type                | "Pt100, 3-wire" if not specified in order |
| Lower bound of calibration range | "0" if not specified in order             |
| Upper bound of calibration range | "100" if not specified in order           |
| Unit of calibration range        | "°C" if not specified in order            |
| Damping constant                 | 2 seconds                                 |
| Sensor burnout                   | High side (110%, 21.6 mA DC) *1           |
| Output when transmitter fails    | High side (110%, 21.6 mA DC) *2           |

\*1: When option code C1 is specified, Low takes effect (-2.5%, 3.6mADC).<sup>T0705.EPS</sup>

\*2: When option code C1 is specified, Low takes effect (-5%, 3.2mADC or less).

## 7.2 Model and Suffix Codes

| Model                     | Basic Specification Codes | Description   |
|---------------------------|---------------------------|---|
| YTA110                    | .....                     | Temperature transmitter (1 input type)                    |
| YTA310                    | .....                     | High precision temperature transmitter (1 input type)     |
| YTA320                    | .....                     | High precision temperature transmitter (2 input type)     |
| Output signal             | -D .....                  | 4 to 20mA DC output, BRAIN communication type             |
|                           | -E .....                  | 4 to 20mA DC output, HART communication type              |
|                           | -F .....                  | FOUNDATION Fieldbus communication type *1                 |
| —                         | A .....                   | Always A  |
| Electrical connection     | 0 .....                   | G1/2 female   |
|                           | 2 .....                   | 1/2 NPT female  |
|                           | 3 .....                   | Pg13.5 female   |
|                           | 4 .....                   | M20 female  |
| Built-in indicator        | D .....                   | Digital indicator   |
|                           | N .....                   | None  |
| Mounting bracket          | B .....                   | SUS304 Stainless steel 2-inch horizontal pipe mounting *2 |
|                           | D .....                   | SUS304 Stainless steel 2-inch vertical pipe mounting *2   |
|                           | N .....                   | None  |
| Additional specifications |                           | / <input type="checkbox"/> Additional specifications      |

\*1: Applicable for YTA320 only.

\*2: Use bolts for wall mounting.

T0703.EPS

## 7.3 Optional Specifications

| Item  | Descriptions   | Code  | YTA110  | YTA310 | YTA320 |   |
|---|--|---|---|--------|--------|---|
| Lightning protector                             | Power supply voltage: 10.5 to 32 V DC<br>Allowable current: Max. 6000A(1×40μs),<br>repeating 1000A(1×40μs) 100 times | A   | ○   | ○      |        |   |
| Painting  | Coating change   | Epoxy resin coating   | X1  | ○      | ○      |   |
|   | Color change   | Amplifier cover only  | Munsell renotation code: N11.5 Black            | P1     | ○      | ○ |
|   |  |   | Munsell renotation code: 7.5BG4/1.5, Jade green | P2     | ○      | ○ |
|   |  | Metallic silver   | P7  | ○      | ○      |   |
| Amplifier and Terminal covers                   | Munsell renotation code: 7.5R4/14 Red  | PR  | ○   | ○      |        |   |
| Stainless Steel Housing*1                       | Housing Material: SCS14A Stainless steel   | E1  | ○   | ○      |        |   |
| Calibration Unit                                | Addition of Degree F and Degree R unit   | D2  | ○   | ○      |        |   |
| Output signal low-side in Transmitter failure*2 | Output signal low-side: -5 %, 3.2 mA DC or less.<br>Sensor burnout is also set to 'Low': -2.5 %, 3.6 mA DC           | C1  | ○   | ○      |        |   |
| NAMUR NE43 compliant*2                          | Output signal limits:<br>3.8 mA to 20.5 mA   | Failure alarm down-scale: output status at CPU failure and hardware error is -5%, 3.2 mA or less. Sensor burnout is also set to 'Low': -2.5%, 3.6 mA  | C2  | ○      | ○      |   |
|   |  | Failure alarm up-scale: output status at CPU failure and hardware error is 110%, 21.6 mA or more. Sensor burnout is also set to 'High': 110%, 21.6 mA | C3  | ○      | ○      |   |
| Data Configuration*2                            | Description into "Descriptor" parameter of HART protocol.<br>(max. 16 characters)                                    | CA  | ○   | ○      |        |   |
| Sensor matching function*2                      | RTD Sensor matching function   | CM1   | ×   | ○      |        |   |

\*1 : Not applicable with other option codes, except for A, C1, D2 and CM1.

\*2 : Not applicable for output signal code F.

T0704.EPS

**[For Explosion Protected Types]**

For FOUNDATION Fieldbus explosion protected type, see IM 01C50T02-01E.

| Item                                 | Descriptions   | Code |
|--------------------------------------|--|------|
| CENELEC ATEX (KEMA)                  | <p>CENELEC ATEX (KEMA) Intrinsically safe, Flameproof approval and Type n combination<br/>[Intrinsically safe approval]<br/>Applicable standard: EN 50014, EN 50020, EN 50284 Certificate: KEMA 02ATEX1026X<br/>II 1G EEx ia IIC T4,T5 Ambient Temperature: -40 to 70°C for T4, -40 to 50°C for T5<br/>Supply/Output circuit: Ui=30V, Ii=165mA, Pi=900mW, Ci=20nF, Li=660µH<br/>Input circuit: Uo=8.6V, Io=30mA, Po=70mW, Co=3µF, Lo=20mH<br/>Electrical Connection: 1/2 NPT female and M20 female*1</p> <p>[Flameproof and Dust Ignition Proof Approval]<br/>Applicable Standard: EN 60079-0, IEC 60079-1, EN 61241-0, EN 61241-1<br/>Certificate: KEMA 07ATEX0130<br/>II 2G Ex d IIC T6/T5, II 2D Ex tD A21 IP67 T70°C, T90°C<br/>Ambient Temperature for Gas Atmospheres: -40 to 75°C for T6, -40 to 80°C for T5<br/>Ambient Temperature for Dust Atmospheres: -40 to 65°C for T70°C, -40 to 80°C for T90°C<br/>Enclosure: IP67<br/>Electrical Connection: 1/2 NPT female and M20 female*1</p> <p>[Type n approval]<br/>Applicable standard: EN60079-15 Referential standard: IEC60079-0, IEC60079-11<br/>II 3G EEx nL IIC T4, T5 Ambient Temperature: -40 to 70°C for T4, -40 to 50°C for T5<br/>Supply/Output circuit: Ui=30V, Ci=20nF, Li=660µH<br/>Input circuit: Uo=8.6V, Io=30mA, Po=70mW, Co=3µF, Lo=20mH<br/>Electrical Connection: 1/2 NPT female and M20 female*1</p> | KU2  |
| Canadian Standards Association (CSA) | <p>CSA Intrinsically safe, non-incendive and Explosionproof approval combination*3<br/>[Intrinsically safe/non-incendive approval]<br/>Applicable standard: C22.2 No0, C22.2 No0.4, C22.2 No25, C22.2 No94, C22.2 No142, C22.2 No157, C22.2 No213 Certificate: 172608-0001053837<br/>Intrinsically safe for Class I, Division 1, Groups A, B, C and D; Class II, Division 1, Groups E, F and G; Class III, Division 1:<br/>Non-incendive for Class I, Division 2, Groups A, B, C and D; Class II, Division 2, Groups E, F and G; Class III, Division 1:<br/>Enclosure Type 4X Temperature Class: T4, Ambient Temperature: -40 to 60°C,<br/>Supply: Vmax=30V, Imax=165mA, Pmax=0.9W, Ci=18nF, Li=730µH<br/>Sensor input: Voc=9V, Isc=40mA, Po=0.09W, Ca=1µF, La=10mH<br/>Electrical Connection: 1/2 NPT female*1</p> <p>[Explosionproof approval]<br/>Applicable standard: C22.2 No0, C22.2 No0.4, C22.2 No25, C22.2 No30, C22.2 No94, C22.2 No142, C22.2 No157, C22.2 No213, C22.2 No1010.1 Certificate: 1089576<br/>Explosionproof Class I, Div.1, Groups B, C and D, Class II, Groups E, F and G, Class III. For Class I, Div.2 Locations "FACTORY SEALED, CONDUIT SEAL NOT REQUIRED"<br/>Enclosure Type 4X Temperature Class: T4 Ambient Temperature: -40 to 60°C<br/>Electrical Connection: 1/2 NPT female*1</p>   | CU1  |
| Factory Mutual (FM)                  | <p>FM Explosionproof approval<br/>Applicable standard: FM 3600, FM 3615, FM 3810, NEMA250<br/>Explosionproof Class I, Division 1, Groups A, B, C and D;<br/>Dust-ignitionproof for Class II/III, Division 1, Groups E, F and G.<br/>"FACTORY SEALED, CONDUIT SEAL NOT REQUIRED." Enclosure Rating: NEMA 4X<br/>Temperature Class: T6 Ambient Temperature: -40 to 60°C (-40 to 140°F)<br/>Electrical Connection: 1/2 NPT female*2</p>   | FF1  |
|                                      | <p>FM Intrinsically safe, non-incendive and Explosionproof approval combination*3<br/>[Intrinsically safe/non-incendive approval]<br/>Applicable standard: FM 3600, FM 3610, FM 3611, FM 3810<br/>Intrinsically safe for Class I, II, III Division 1 Groups A, B, C, D, E, F and G.<br/>Non-incendive for Class I, II, Division 2 Groups A, B, C, D, E, F and G Class III, Division 1.<br/>Enclosure Type: 4X Temperature Class: T4 Ambient Temperature: -40 to 60°C (-40 to 140°F)<br/>Supply: Vmax=30V, Imax=165mA, Pmax=0.9W, Ci=18nF, Li=730µH<br/>Sensor: Voc=9V, Isc=40mA, Po=90mW, Ca=1µF, La=10mH</p> <p>[Explosionproof approval]<br/>Applicable standard: FM 3600, FM 3615, FM 3810, NEMA250<br/>Class I, Division 1, Groups A, B, C and D.;<br/>Dust-ignitionproof for Class II/III, Division 1, Groups E, F and G.<br/>"FACTORY SEALED, CONDUIT SEAL NOT REQUIRED." Enclosure Ratings: NEMA4X<br/>Temperature Class: T6 Ambient Temperature: -40 to 60°C (-40 to 140°F)<br/>Electrical Connection: 1/2NPT female*2</p>   | FU1  |

T0706-1.EPS

\*1 : Applicable for Electrical Connection Code 2 and 4.

\*2 : Applicable for Electrical Connection Code 2.

\*3 : Not applicable for Output Signal Code F.

## 7. GENERAL SPECIFICATIONS

| Item                                     | Descriptions   | Code       |            |
|--|--|------------|------------|
| Standards Association of Australia (SAA) | SAA Intrinsically safe, non-sparking and Flameproof approval combination<br>[Intrinsically safe and non-sparking]<br>Applicable standard: AS2380.1, AS2380.7, AS2380.9 Certificate: AUS Ex 3652X<br>Ex ia IIC T4 (Tamb=70°C) IP66/67, Ex n IIC T4 (Tamb=70°C), IP66/67<br>Input parameters: Ui=30V, Ii=165mA, Pi=0.9W<br>Output parameters: Uo=8.6V, Io=30mA, Po=62mW, Co=1μF<br>[Flameproof approval]<br>Applicable standard: AS2380.1, AS2380.2 Certificate: AUS Ex 3640<br>Ex d IIC T6 (Tamb=75°C) IP66/67<br>Electrical connection: 1/2 NPT female, Pg13.5 female and M20 female*5 | <b>SU1</b> |            |
| Japanese Industrial Standards (TIIS)     | TIIS Flameproof approval<br>Ex ds IIC T6 X                      Amb. Temp.: -20 to 60°C  | <b>JF3</b> |            |
| Attached flameproof packing adapter*4    | Electrical connection: G1/2 female<br>Applicable cable: O.D. 8.5 to 11 mm  | 1 pc.      | <b>G11</b> |
|  |  | 2 pc.      | <b>G12</b> |
| IECEX Scheme*6                           | ECEX Flameproof and Dust ignition proof Approval<br>Applicable Standard: IEC 60079-0, IEC 60079-1, IEC 61241-0, OEC 61241-1<br>Certificate: IECEX KEM 07.0044<br>Ex d IIC T6/T5, Ex tD A21 IP67 T70°C, T90°C<br>Ambient Temperature for Gas Atmospheres: -40 to 75°C (-40 to 167°F) for T6,<br>-40 to 80°C (-40 to 176°F) for T5<br>Ambient Temperature for Dust Atmospheres: -40 to 65°C (-40 to 149°F) for T70°C,<br>-40 to 80°C (-40 to 176°F) for T90°C<br>Enclosure: IP67<br>Electrical Connection: 1/2 NPT female and M20 female   | <b>SF2</b> |            |

T0706-2.EPS

\*4 : If cable wiring is to be used to a TIIS flameproof type transmitter, do not fail to add the YOKOGAWA-assured flameproof packing adapter.

\*5 : Applicable for Electrical connection code 2, 3 and 4.

\*6 : Applicable only for Australia, New Zealand area.



## 7.4 Dimensions

Unit: mm (Approx. inch)

### ● 2-inch horizontal pipe mounting

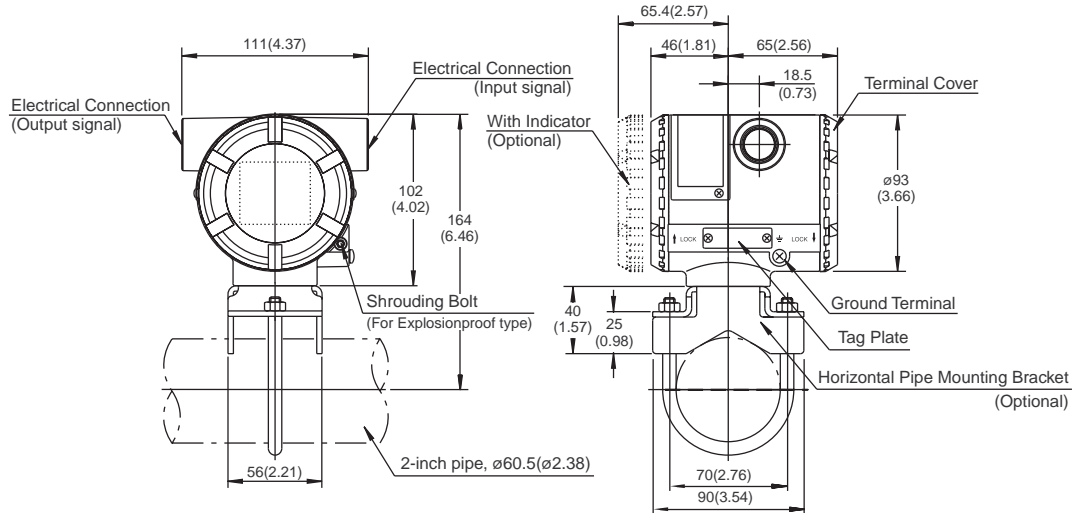

### ● 2-inch vertical pipe mounting

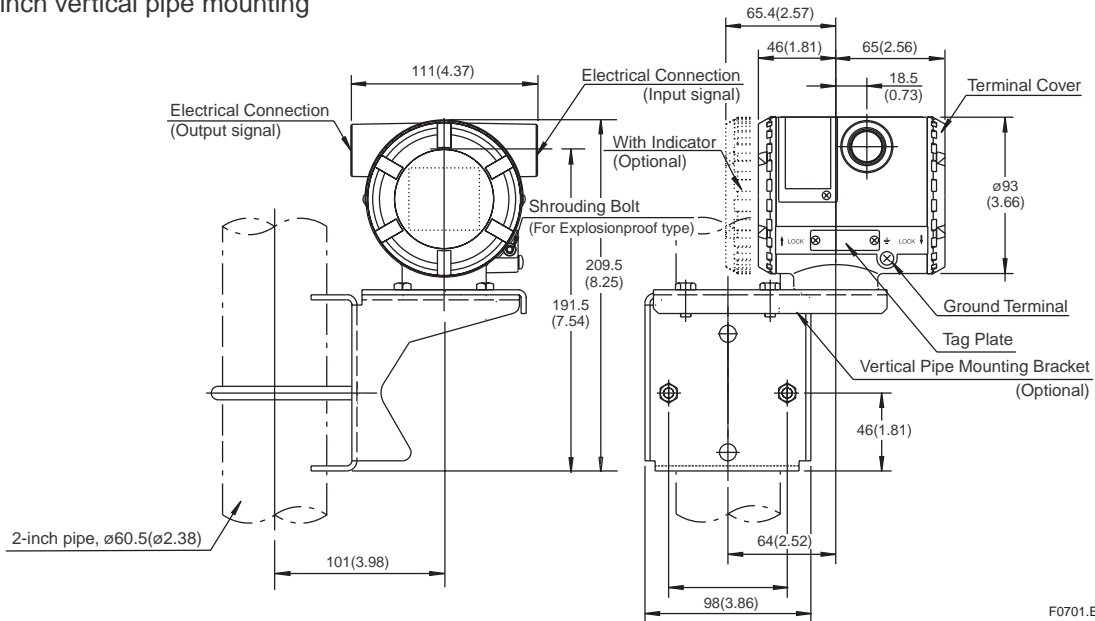

F0701.EPS

# INSTALLATION AND OPERATING PRECAUTIONS FOR TIIS FLAMEPROOF EQUIPMENT

## Apparatus Certified Under Technical Criteria (IEC-compatible Standards)

### 1. General

The following describes precautions on electrical apparatus of flameproof construction (hereinafter referred to as flameproof apparatus) in explosion-protected apparatus.

Following the Labour Safety and Health Laws of Japan, flameproof apparatus is subjected to type tests to meet either the technical criteria for explosionproof electrical machinery and equipment (standards notification no. 556 from the Japanese Ministry of Labour) (hereinafter referred to as technical criteria), in conformity with the IEC Standards, or the “Recommended Practice for Explosion-Protected Electrical Installations in General Industries,” published in 1979. These certified apparatus can be used in hazardous locations where explosive or inflammable gases or vapours may be present.

Certified apparatus includes a certification label and an equipment nameplate with the specifications necessary for explosion requirements as well as precautions on explosion protection. Please confirm these precautionary items and use them to meet specification requirements.

For electrical wiring and maintenance servicing, please refer to “Internal Wiring Rules” in the Electrical Installation Technical Standards as well as “USER’S GUIDELINES for Electrical Installations for Explosive Gas Atmospheres in General Industry,” published in 1994.

To meet flameproof requirements, equipment that can be termed “flameproof” must:

- (1) Be certified by a Japanese public authority in accordance with the Labour Safety and Health Laws of Japan and have a certification label in an appropriate location on its case, and
- (2) Be used in compliance with the specifications marked on its certification label, equipment nameplate and precautionary information furnished.

### 2. Electrical Apparatus of Flameproof Type of Explosion-Protected Construction

Electrical apparatus which is of flameproof construction is subjected to a type test and certified by the Japanese Ministry of Labour aiming at preventing explosion caused by electrical apparatus in a factory or any location where inflammable gases or vapours may be present. The flameproof

construction is of completely enclosed type and its enclosure shall endure explosive pressures in cases where explosive gases or vapours entering the enclosure cause explosion. In addition, the enclosure construction shall be such that flame caused by explosion does not ignite gases or vapours outside the enclosure.

In this manual, the word "flameproof" is applied to the flameproof equipment combined with the types of protection "e", "o", "i", and "d" as well as flameproof equipment.

### 3. Terminology

#### (1) Enclosure

An outer shell of an electrical apparatus, which encloses live parts and thus is needed to configure explosion-protected construction.

#### (2) Shroud

A component part which is so designed that the fastening of joint surfaces cannot be loosened unless a special tool is used.

#### (3) Enclosure internal volume

This is indicated by:— the total internal volume of the flameproof enclosure minus the volume of the internal components essential to equipment functions.

#### (4) Path length of joint surface

On a joint surface, the length of the shortest path through which flame flows from the inside to outside of the flameproof enclosure. This definition cannot be applied to threaded joints.

#### (5) Gaps between joint surfaces

The physical distance between two mating surfaces, or differences in diameters if the mating surfaces are cylindrical.

Note: The permissible sizes of gaps between joint surfaces, the path length of a joint surface and the number of joint threads are determined by such factors as the enclosure’s internal volume, joint and mating surface construction, and the explosion classification of the specified gases and vapours.

## 4. Installation of Flameproof Apparatus

### (1) Installation Area

Flameproof apparatus may be installed, in accordance with applicable gases, in a hazardous area in Zone 1 or 2, where the specified gases are present. Those apparatus shall not be installed in a hazardous area in Zone 0.

Note: Hazardous areas are classified in zones based upon the frequency of the appearance and the duration of an explosive gas atmosphere as follows:

Zone 0: An area in which an explosive gas atmosphere is present continuously or is present for long periods.

Zone 1: An area in which an explosive gas atmosphere is likely to occur in normal operation.

Zone 2: An area in which an explosive gas atmosphere is not likely to occur in normal operation and if it does occur it will exist for a short period only.

### (2) Environmental Conditions

The standard environmental condition for the installation of flameproof apparatus is limited to an ambient temperature range from  $-20^{\circ}\text{C}$  to  $+40^{\circ}\text{C}$  (for products certified under Technical Criteria). However, some field-mounted instruments may be certified at an ambient temperature up to  $+60^{\circ}\text{C}$  as indicated on the instrument nameplates. If the flameproof apparatus are exposed to direct sunshine or radiant heat from plant facilities, appropriate thermal protection measures shall be taken.

## 5. External Wiring for Flameproof Apparatus

Flameproof apparatus require cable wiring or flameproof metal conduits for their electrical connections. For cable wiring, cable glands (cable entry devices for flameproof type) to wiring connections shall be attached. For metal conduits, attach sealing fittings as close to wiring connections as possible and completely seal the apparatus. All non-live metal parts such as the enclosure shall be securely grounded. For details, see the "USER'S GUIDELINES for Electrical Installations for Explosive Gas Atmospheres in General Industry," published in 1994.

### (1) Cable Wiring

- For cable wiring, cable glands (cable entry devices for flameproof type) specified or supplied with the apparatus shall be directly attached to the wiring connections to complete sealing of the apparatus.
- Screws that connect cable glands to the apparatus are those for G-type parallel pipe threads (JIS B 0202) with no sealing property. To protect the apparatus from corrosive gases or moisture, apply nonhardening sealant such as liquid gaskets to those threads for waterproofing.
- Specific cables shall be used as recommended by the "USER'S GUIDELINES for Electrical Installations for Explosive Gas Atmospheres in General Industry," published in 1994.
- In necessary, appropriate protective pipes (conduit or flexible pipes), ducts or trays shall be used for preventing the cable run (outside the cable glands) from damage.
- To prevent explosive atmosphere from being propagated from Zone 1 or 2 hazardous location to any different location or non-hazardous location through the protective pipe or duct, apply sealing of the protective pipes in the vicinity of individual boundaries, or fill the ducts with sand appropriately.
- When branch connections of cables, or cable connections with insulated cables inside the conduit pipes are made, a flameproof or increased-safety connection box shall be used. In this case, flameproof or increased-safety cable glands meeting the type of connection box must be used for cable connections to the box.

### (2) Flameproof Metal Conduit Wiring

- For the flameproof metal conduit wiring or insulated wires shall be used as recommended by the USER'S GUIDELINES for Electrical Installations for Explosive Gas Atmospheres in General Industry, published in 1994.
- For conduit pipes, heavy-gauge steel conduits conforming to JIS C 8305 Standard shall be used.
- Flameproof sealing fittings shall be used in the vicinity of the wiring connections, and those fittings shall be filled with sealing compounds to complete sealing of the apparatus. In addition, to prevent explosive gases, moisture, or flame caused by explosion from being propagated through the conduit, always provide sealing fittings to complete sealing of the conduit in the following locations:
  - (a) In the boundaries between the hazardous and non-hazardous locations.
  - (b) In the boundaries where there is a different classification of hazardous location.
- For the connections of the apparatus with a conduit pipe or its associated accessories, G-type parallel pipe threads (JIS B 0202) shall be used to provide a minimum of five-thread engagement to complete tightness. In addition, since these parallel threads do not have sealing property, nonhardening sealant such as liquid gaskets shall thus be applied to those threads for ensuring waterproofness.
- If metal conduits need flexibility, use flameproof flexible fittings.

## 6. Maintenance of Flameproof Apparatus

To maintain the flameproof apparatus, do the following. (For details, see Chapter 10 “MAINTENANCE OF EXPLOSION-PROTECTED ELECTRICAL INSTALLATION” in the USER’S GUIDELINES for Electrical Installations for Explosive Gas Atmospheres in General Industry.)

### (1) Maintenance servicing with the power on.

Flameproof apparatus shall not be maintenance-serviced with its power turned on. However, in cases where maintenance servicing is to be conducted with the power turned on, with the equipment cover removed, always use a gas detector to check that there is no explosive gas in that location. If it cannot be checked whether an explosive gas is present or not, maintenance servicing shall be limited to the following two items:

- (a) Visual inspection  
Visually inspect the flameproof apparatus, metal conduits, and cables for damage or corrosion, and other mechanical and structural defects.
- (b) Zero and span adjustments  
These adjustments should be made only to the extent that they can be conducted from the outside without opening the equipment cover. In doing this, great care must be taken not to cause mechanical sparks with tools.

### (2) Repair

If the flameproof apparatus requires repair, turn off the power and transport it to a safety (non-hazardous) location. Observe the following points before attempting to repair the apparatus.

- (a) Make only such electrical and mechanical repairs as will restore the apparatus to its original condition. For the flameproof apparatus, the gaps and path lengths of joints and mating surfaces, and mechanical strength of enclosures are critical factors in explosion protection. Exercise great care not to damage the joints or shock the enclosure.
- (b) If any damage occurs in threads, joints or mating surfaces, inspection windows, connections between the transmitter and terminal box, shrouds or clamps, or external wiring connections which are essential in flameproofness, contact Yokogawa Electric Corporation.



### CAUTION

Do not attempt to re-process threaded connections or refinish joints or mating surfaces.

- (c) Unless otherwise specified, the electrical circuitry and internal mechanisms may be repaired by component replacement, as this will not directly affect the

requirements for flameproof apparatus (however, bear in mind that the apparatus must always be restored to its original condition). If you attempt to repair the flameproof apparatus, company-specified components shall be used.

- (d) Before starting to service the apparatus, be sure to check all parts necessary for retaining the requirements for flameproof apparatus. For this, check that all screws, bolts, nuts, and threaded connections have properly been tightened.

### (3) Prohibition of specification changes and modifications

Do not attempt to change specifications or make modifications involving addition of or changes in external wiring connections.

## 7. Selection of Cable Entry Devices for Flameproof Type



### IMPORTANT

The cable glands (cable entry devices for flameproof type) conforming to IEC Standards are certified in combination with the flameproof apparatus. So, Yokogawa-specified cable entry devices for flameproof type shall be used to meet this demand.

### References:

- (1) Type Certificate Guide for Explosion-Protected Construction Electrical Machinery and Equipment (relating to Technical Standards Conforming to International Standards), issued by the Technical Institution of Industrial Safety, Japan
- (2) USER’S GUIDELINES for Electrical Installations for Explosive Gas Atmospheres in General Industry (1994), issued by the Japanese Ministry of Labour, the Research Institute of Industrial Safet

# Customer Maintenance Parts List

## YTA Series Temperature Transmitter [ Style : S3 ]

YTA SERIES

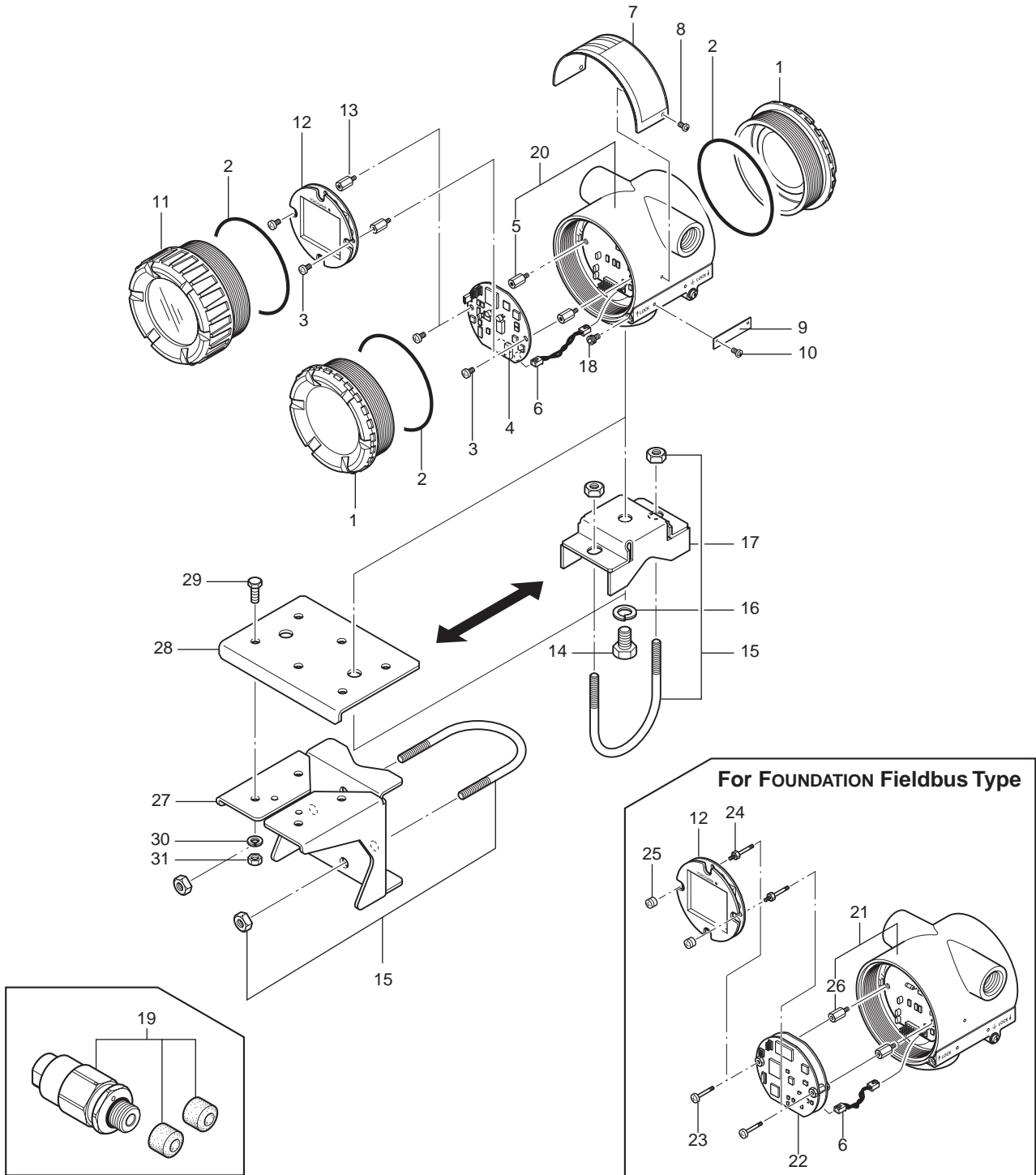

YTA\_CMPL.EPS

| Item | Part No.         | Qty | Description   |
|------|------------------|-----|---|
| 1    | F9165EA          | 2   | Cover   |
| 2    | B1000ER          | 2   | O-Ring  |
| 3    | Y9406JB          | 2   | Screw Machine   |
| 4    | See Table 1      | 1   | CPU Assembly for BRAIN or HART Communication type   |
| 5    | B1002BT          | 2   | Stud Bolt   |
| 6    | F9342MW          | 1   | Connector Assembly  |
| 7    | —                | 1   | Name Plate  |
| 8    | F9300AG          | 2   | Screw   |
| 9    | F9165DF          | 1   | Tag Plate   |
| 10   | F9300AG          | 2   | Screw   |
| 11   | F9165FA          | 1   | Cover Assembly  |
| 12   | F9167DA          | 1   | LCD Assembly  |
| 13   | B1001BT          | 2   | Stud Bolt   |
| 14   | Y9016NU          | 1   | Bolt Hexagon  |
| 15   | D0117XL-A        | 1   | U-bolt Assembly   |
| 16   | Y9100SU          | 1   | Washer Spring   |
| 17   | F9165CY          | 1   | Bracket   |
| 18   | Y9406ZU          | 2   | Screw (for CENELEC, SAA and TIIS flameproof type)   |
| 19   | Below<br>G9601AM | 1   | Cable Grand Assembly (for JIS Flameproof; option code: /JF3)<br>For Electrical Connection: G 1/2 female (option code: /G11) |
| 20   | —                | 1   | Case Assembly for BRAIN or HART Communication type  |
| 21   | —                | 1   | Case Assembly for Fieldbus Communication type   |
| 22   | —                | 1   | CPU Assembly for Fieldbus Communication type  |
| 23   | Y9420JB          | 2   | Screw Machine   |
| 24   | F9165KA          | 2   | Screw   |
| 25   | F9165KF          | 2   | Nut   |
| 26   | F9165KD          | 2   | Stud Bolt   |
| 27   | F9284NZ          | 1   | Bracket   |
| 28   | F9165QB          | 1   | Bracket   |
| 29   | Y9616NU          | 4   | Screw   |
| 30   | Y9600SU          | 4   | Washer  |
| 31   | Y9601BU          | 4   | Nut   |

**Table 1. CPU Assembly (for BRAIN and HART)**

| Model  | Communication protocol | Without /CM1 | With /CM1 |
|--------|------------------------|--------------|-----------|
| YTA110 | -D (BRAIN)             | F9167BJ      | —         |
|        | -E (HART)              | F9167BM      | —         |
| YTA310 | -D (BRAIN)             | F9167BK      | F9167BU   |
|        | -E (HART)              | F9167BN      | F9167BW   |
| YTA320 | -D (BRAIN)             | F9167BL      | F9167BV   |
|        | -E (HART)              | F9167BP      | F9167BX   |

CPU Assembly is shipped with the setting shown in Table 2.

**Table 2. Setting upon shipment**

|                               |                         |
|-------------------------------|-------------------------|
| Input sensor type             | Pt100 three-wire system |
| Calibration range lower limit | "0"                     |
| Calibration range upper limit | "100"                   |
| Calibration unit              | "°C"                    |
| Sensor burnout                | High (110%, 21.6mA DC)  |

# REVISION RECORD

Title: Model YTA series Temperature Transmitter (Hardware) [Style: S3]  
Manual No.: IM 01C50B01-01E

| Edition | Date      | Page   | Revised item   |
|---------|-----------|--|--|
| 1st     | Sep. 1998 | —  | New Publication  |
| 2nd     | Nov. 1998 | 2-5<br>2-7<br>2-9<br>5-5<br>7-2 to 7-3   | 2.7.1 Add subsection 2.7.1 CSA certification.<br>2.7.2 Add subsection 2.7.2 CENELEC(KEMA) certificated.<br>2.8 Add subsection 2.8 EMC Conformity Standards.<br>5.5 Add wiring cautions for intrinsically safe type and flameproof type.<br>7.1 Correct errors.   |
| 3rd     | Jan. 1999 | 2-9<br>5-3<br>6-2<br>6-7<br>6-9<br>7-1<br>7-5<br>7-6<br>CMPL   | 2.7.3 Add subsection 2.7.3 FM certification.<br>5.4 Delete resistance 4-wire type. (Figure 5.6 & 5.7)<br>6.2.2 Delete resistance 4-wire type. (Figure 6.1)<br>6.4. Add HART parameter.<br>6.5 Correct errors. (Er-05 & Er-06 in Table 6.4)<br>7.1 Delete resistance 4-wire type<br>7.3 Add optional code /FF1.<br>7.4 Add Terminal dimensions.<br>CMPL 1C50B1-02E 1st to 2nd<br>Page 1 Correct dimensions  |
| 4th     | June 1999 | Contents<br>2-1<br>2-7<br>2-10<br>2-12<br>2-13<br>5-1<br>5-3<br>5-6<br>6-3<br>7-4<br>Ex-B02E<br>CMPL | Add Ex-B02E 'Installation and Operating Precautions for JIS Flameproof Equipment'.<br>2.1 Add C-tick mark.<br>2.7.2 Add IEC (KEMA) Type of protection 'n'<br>2.7.3 Add FM Intrinsically Safe Type<br>2.7.4 Add JIS Flameproof Type<br>2.8 Add C-tick mark<br>5.1 Add 'IMPORTANT' for JIS Flameproof type.<br>5.3.2 Add 'WARNING' for JIS Flameproof type.<br>5.5(2) Add cable wiring procedure using Flameproof Packing adapter.<br>6.3 Add Figure 6.3.<br>7.3 Add optional code /CM1, /FU1, /JF3, /G11, and /G12.<br>Add Ex-B02E 'Installation and Operating Precautions for JIS Flameproof Equipment'.<br>Add item 18, 19, 20, and 21. |
| 5th     | July 2000 | —  | —  |
| 6th     | July 2000 | Cover<br>Contents<br>2-13<br>7-1<br>7-3<br>7-4<br>CMPL   | Add Style code<br>Add 2.7.5<br>Add '2.7.5 SAA Certification'<br>7.1 Correct Description of Ambient temperature effect<br>Add Table 7.2 YTA110 Effect of Ambient Temperature'<br>7.4 Add Stainless steel housing<br>Change Item 4   |
| 7th     | July 2001 | 2-15<br>7-1<br>7-4 to 7-6<br>EX-B03E<br>CMPL   | 2-15 Change referred standard<br>7. Add Notes for Fieldbus type, change EMC standard.<br>7.1 Add codes and notes for Fieldbus type.<br>EX-B02E superseded to EX-B03E.<br>CMPL 4th to 5th edition (Adding Fieldbus related parts)   |
| 8th     | May 2002  | 1-1<br>2-5<br>7-6<br>CMPL  | Add "■ For Safety Using."<br>2.7.2 Add descriptions based on ATEX directive.<br>7.3 Add Optional code KU2.<br>CMPL 6th to 7th edition (Fieldbus Type Part No. correction)<br>1. Item 5, B1002BT to Item 26, F9165KD<br>2. Item 23, F9165KA (Screw) to Y9420JB (Screw machine)<br>3. Item 24, Y9420JB (Screw machine) to F9165KA (Screw)<br>CMPL 1C50B1-02E 7th to CMPL 01C50B01-02E 8th  |

Rev.1.EPS

| Edition | Date      | Page  | Revised item  |
|---------|-----------|---|---|
| 9th     | Apr. 2003 | 2-1<br>4-1<br>7-5<br>7-7<br>CMPL  | Add Vertical pipe mounting bracket.<br>Add Vertical pipe mounting bracket.<br>7.2 Add mounting bracket code D.<br>7.4 Change Dimensions.<br>CMPL 01C50B01-02E 8th to 9th<br>Add Part No.<br>Item Part No.<br>27 F9284NZ<br>28 F9165QB<br>29 F9616NU<br>30 Y9600SU<br>31 Y9601BU   |
| 10th    | Dec. 2004 | —<br>Contents<br>1-2<br>1-3<br>2-6<br>3-1<br>6-2<br>7-5<br>CMPL   | Change Title of Flameproof (JIS → TIIS)<br>Add 'ATEX Documentation.'<br>1. Add Attention on Maintenance.<br>1. Add ATEX Documentation.<br>2.7.2 Correct errors.<br>3.1 Add Notes for Lock screw.<br>6.3 Add Description about SAA to CAUTION.<br>7.3 Add C2, C3 Options.<br>CMPL 9th to 10th edition.<br>Delete Part Number of Name Plate.<br>Add Note for Lock screw.<br>Add Ports Number of CPU Assembly for /KS25. |
| 11th    | Sep. 2006 | Cover<br>Contents<br>2-3, 2-4<br>2-5, 2-6<br>2-8, 2-9<br>2-10<br>2-11<br>6-6<br>7-1<br>7-3<br>7-5<br>7-6, 7-7 | Change Style Code<br>Add 2.9 Low Voltage Directive<br>2. Add Certificate Number and Applicable Standard for Explosion Protected Types.<br>2.9 Add 2.9 Low Voltage Directive.<br>6.5 Add Error code.<br>7.1 Add Stability Specifications.<br>7.1 Add Note for YTA110 Ambient Temperature Effect.<br>7.3 Add Optional Code CA.<br>7.3 Add Certificate Number and Applicable Standard for Explosion Protected Types.     |
| 12th    | Nov. 2007 | 2-6, 7-6<br>2-11, 7-7<br>7-5<br>CMPL  | 2.7.2 Change Applicable standards and add Dust Ignition Proof for KU2.<br>2.7.6 Add IECEx Certification.<br>7.3 Add Option PR.<br>CMPL Add setting upon shipment for CPU Assembly.  |

Rev.2.EPS