

Dear customer,

Please read these operating instructions carefully.

Pay particular attention to the section "Safety information" on the first few pages. Please retain these operating instructions for later reference. Pass them on to possible new owners of the appliance.

The following symbols are used in the text:



Safety instructions

Warning: Information concerning your personal safety.

Important: Information on how to avoid damaging the appliance.



Information and practical tips



Environmental information

1. These numbers indicate step by step how to use the appliance.

2. ...

3. ...

These operating instructions contain information on steps you can take yourself to rectify a possible malfunction. Refer to the section "What to do if...".

In the event of any technical problems please contact your nearest customer service centre at any time. (Addresses and telephone numbers may be found in the appendix under "Customer Service Centres").

You should also refer to the section "Service".

Printed on recycled paper.

Thinking ecologically means acting ecologically ...

Contents

Operating Instructions	41
Safety	41
Disposal	43
The Key Features of Your Appliance	44
Description of the Appliance	45
Cooking zones and control panel.....	45
Digital Displays.....	46
Cooking Zone Safety Cut-out.....	46
Before Using for the First Time	47
Initial Cleaning.....	47
Operating the Hob	47
Touch Control Sensor Field.....	47
Switching On the Appliance.....	47
Switching Off the Appliance.....	48
Cooking Zone Selection.....	48
Heat Setting Selection.....	49
Switching the Triple Ring Cooking Zone On and Off.....	49
Switching the Casserole Zone On and Off.....	51
Switching off a Cooking Zone.....	52
Residual Heat Indicator.....	52
Cooking with the Automatic Warm up Function.....	53
Cooking without the Automatic Warm up Function.....	54
Locking/Unlocking the Control Panel.....	55
Timer.....	56
Power Management.....	58
Uses, Tables and Tips	60
Pans.....	60
Advice on Cooking with and without Automatic Warm up.....	61
Cleaning and Care	63
Hob.....	63
Hob Frame.....	64
What to do if	65
Rectifying faults.....	65

Installation Instructions	67
Technical Data	67
Regulations, Standards, Directives	68
Safety Instructions for the Installer	69
Electrical Connection	70
Service	73
Assembly	146

Operating Instructions

Safety

The safety aspects of this appliance comply with accepted technical standards and the German Appliance Safety Law. However, as manufacturers we also believe it is our responsibility to familiarise you with the following safety instructions.

Electrical Safety

- The installation and connection of the new appliance must only be carried out by qualified personnel.
- Repairs to the appliance are only to be carried out by approved service engineers. Repairs carried out by inexperienced persons may cause injury or serious malfunctioning. If your appliance needs repairing, please contact your local customer center or your dealer.



Please follow these instructions, otherwise the warranty will not cover any damage that may occur.

- Flush-mounted appliances may only be operated following installation in suitable installation cabinets and workplaces which conform to the relevant standards. This ensures sufficient protection against contact for electrical units as required by the VDE [Association of German Electrical Engineers].
- If your appliance malfunctions or if fractures, cracks or splits appear:
 - switch off all cooking zones,
 - disconnect the hob from the electricity supply.

Child Safety

The cooking zones will become hot when you cook. Therefore, always keep small children away from the appliance.

Safety During Use

- This appliance may only be used for normal cooking and frying in the home. It is not designed for commercial or industrial purposes.
- Do not use the hob to heat the room.
- Take care when plugging electric appliances into mains sockets near the hob. Connection leads must not come into contact with the hot surface.

- Overheated fats and oils catch fire quickly. You should supervise cooking when preparing foods in fat or oil (e.g. chips).
- Switch off the cooking zones after use.

Safety When Cleaning

- For safety reasons do not clean the appliance with a steam jet or high pressure cleaner.
- Clean the hob in accordance with the maintenance and cleaning instructions in this manual.

To Avoid Damaging Your Appliance

- Do not use the hob as a work surface or for storage.
- Do not operate the cooking zones when there is no pan or the pans are empty.
- Ceramic glass is insensitive to temperature shock and very robust; however it is not unbreakable. Especially sharp and hard objects that fall on the cooking surface can damage it.
- Do not use cast iron pans or pans with a rough, burred or damaged base. Scratching may occur if the pans are slid across the surface.
- Do not place any pans on the hob frame. Scratching and damage to the paint may occur.
- Make sure that no acidic liquids, e.g. vinegar, lemon or descaling agents, are spilt onto the hob frame, since these cause dull spots.
- If sugar or a preparation with sugar comes into contact with the hot cooking zone and melts there it must be cleaned off immediately with a scraper while it is still hot. If it cools, the surface may be damaged when it is removed.
- Keep all items and materials that can melt away from the ceramic glass surface, e.g. plastics, aluminium foil, or oven foils. If something of this nature should melt onto the ceramic glass surface, it must also be removed immediately using the scraper.



Disposal

Disposing of the packaging material

All materials used can be fully recycled.

Plastics are marked as follows:

- >PE< for polyethylene, as used for the outer wrapping and the bags inside.
- >PS< for polystyrene foam, e.g., as used for the padding materials. They are completely free of CFCs.

Disposal of old appliances





Warning: Before disposing of old appliances please make them inoperable so that they cannot be the source of danger.

To do this, disconnect the appliance from the mains supply and remove the mains lead.

To protect the environment, it is important that worn out appliances are disposed of in the correct manner.

- The appliance must not be disposed of with household rubbish.
- You can obtain information about collection dates or public refuse disposal sites from your local refuse department or council.

The Key Features of Your Appliance

- **Glass ceramic cooking surface:** The appliance has a glass ceramic cooking surface and 5 rapid response cooking zones. The particularly powerful radiant heater elements significantly shorten the amount of time taken for the zones to heat up.
- **Sensor fields:** Your appliance is operated using Touch Control sensor fields.
- **Cleaning:** The advantage of the ceramic glass cooking surface and the sensor fields is their accessibility for cleaning. The smooth, flat surface is easy to clean.
- **On/Off sensor field:** The "On/Off" sensor field provides the appliance with a separate mains switch. Touching this switches the power supply on or off completely.
- **Control and function indicators:** Digital indicators or control lamp provide information about settings made, functions activated, as well as any residual heat of the corresponding cooking zone.
- **Safety cut-out:** A safety cut-out ensures that all cooking zones switch off automatically after a period of time if the setting has not been changed.
- **Keep warm setting:**  is the setting for keeping foods warm.
- **Residual heat indicator:** An  for residual heat is shown in the display if the cooking zone becomes so hot that there is a risk of burning.
- **Frying zone:** The hob has a special frying zone. This can be set to either the round or the oval shape, for example when using a fryer.
- **Triple ring cooking zone:** The hob features a triple-ring cooking zone. This zone can be set to different sizes, for example to fit smaller pots. This will save power.
- **Timer:** All zones can be automatically switched off using the integrated timer. When the end of the cooking time has been reached, the cooking zone switches off.
- **Power Management:** When the front left, rear right and front right cooking zones are used simultaneously the hob control automatically brings about the optimal distribution of heating power (see section "Power Management").





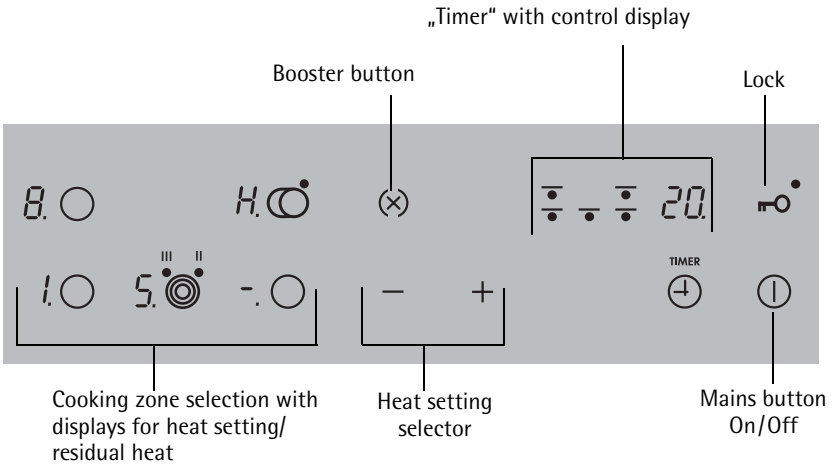
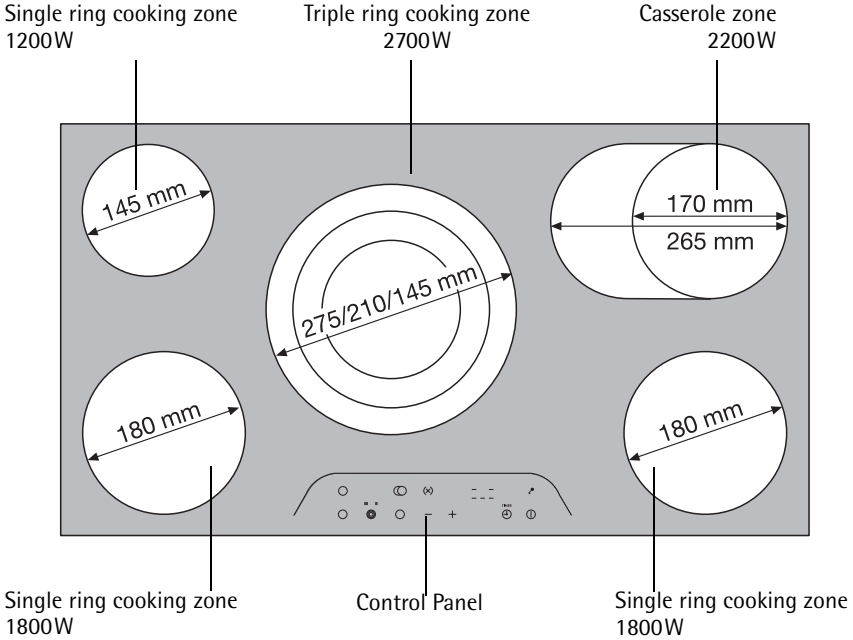

Description of the Appliance

Cooking zones and control panel



Digital Displays



The four display fields that are assigned to the four cooking zones display:

- , after being switched on and when the safety function causes an automatic cut-out,
-  when a cooking zone is selected,
-  to , depending on the selected heat setting,
-  during automatic warm up,
-  when there is residual heat,
-  when there is a fault.



Cooking Zone Safety Cut-out

If one of the cooking zones is not switched off after a certain time or if the heat setting is not changed, the corresponding cooking zone switches itself off automatically.

 appears in the ring display for all rings that are switched on, and  after they have cooled down.

The rings are switched off at:

- Heat setting 1 - 2 after 6 hours
- Heat setting 3 - 4 after 5 hours
- Heat setting 5 after 4 hours
- Heat setting 6 - 9 after 1.5 hours



If one or more cooking zones switch off before the times indicated see section "What to do if ...".

Cancelling the Safety Cut-out

To cancel the activated safety cut-out the appliance must be switched off and then on again using the ON/OFF  sensor field. After this the cooking zones are again ready for use.

Switching Off for Other Reasons

Liquid that boils over onto the control panel causes all cooking zones to switch off immediately.

If you place a wet cloth on the control panel it has the same effect. In both cases the appliance has to be switched on again using the mains switch  after removing the liquid or cloth.

Before Using for the First Time

Initial Cleaning

Wipe the ceramic glass surface with a damp cloth.



Important: Do not use any caustic, abrasive cleaners! The surface could be damaged.

Operating the Hob



When a cooking zone is switched on, it may hum briefly. This is a characteristic of all ceramic glass cooking zones and does not impair either the function or the life of the appliance.

Touch Control Sensor Field

To operate the Touch Control sensor field place your finger from above flat onto the required field until the appropriate displays come on or go out or the required function is carried out.

Switching On the Appliance

The entire appliance is switched on using the "On/Off"  sensor field. Touch the "On/Off" sensor field for approx. 2 seconds.

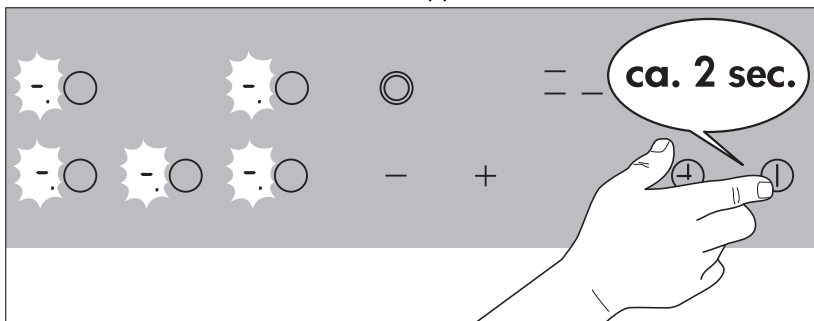

The digital displays will show  and the decimal point will flash.





Once the "On/Off" sensor field has been operated to switch on the appliance, one of the cooking zones must be selected within approx. 10 seconds using the cooking zone selection buttons. Otherwise the appliance switches off again for safety reasons.

Switching Off the Appliance

To switch off the appliance completely activate the "On/Off"  sensor field.

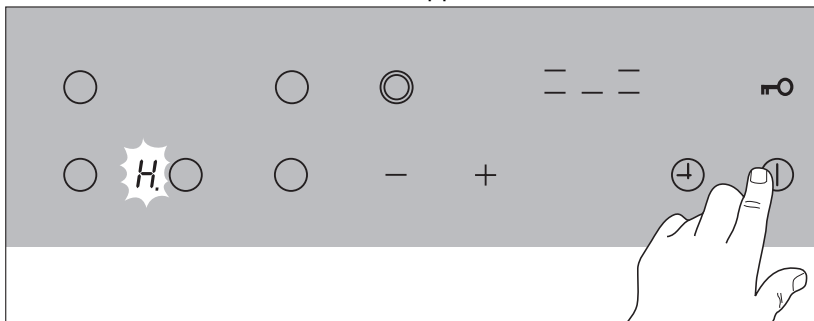
Touch the "On/Off" sensor field for approx. 1 second.





-  When an individual cooking zone or the entire hob is switched off, any residual heat is shown with an  (for "Hot") in the digital display for the appropriate cooking zones.

Cooking Zone Selection

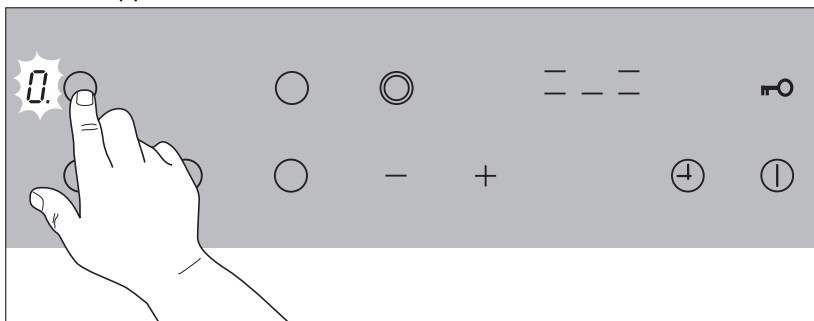
To select the required cooking zone touch the corresponding sensor field for approx. one second.



A zero with a decimal point will light up in the appropriate cooking zone display window .

-  The decimal point indicates that settings may only be made for this cooking zone.

Heat Setting Selection

For setting and adjusting the heat setting (1 to 9) for the selected cooking zone.

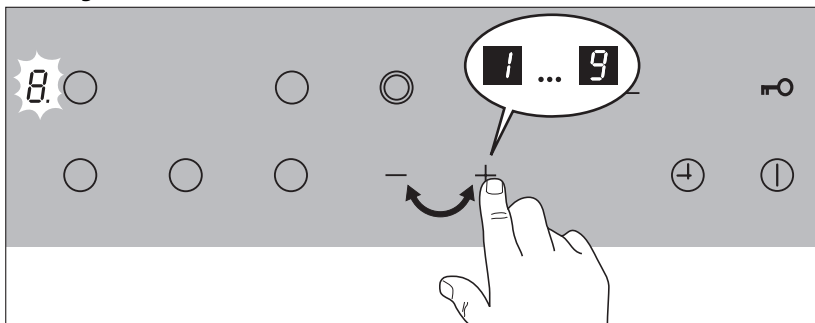

Use sensor field \oplus to increase the heat setting.

Lower the heat setting with sensor field \ominus .

- i** If several cooking zones are being used simultaneously, the required cooking zone must be selected by touching the appropriate sensor field before adjusting the heat setting. The decimal point in the display shows which cooking zone has been selected.

Switching the Triple Ring Cooking Zone On and Off

Depending on the size of the pot or pan, when using the triple ring cooking zone each of the larger cooking rings can be switched on in turn, in addition to the smallest cooking zone, using the "booster" sensor field on the control panel.

- i** These can only be activated if the smaller ring is already switched on.

1. Select the appropriate cooking zone.

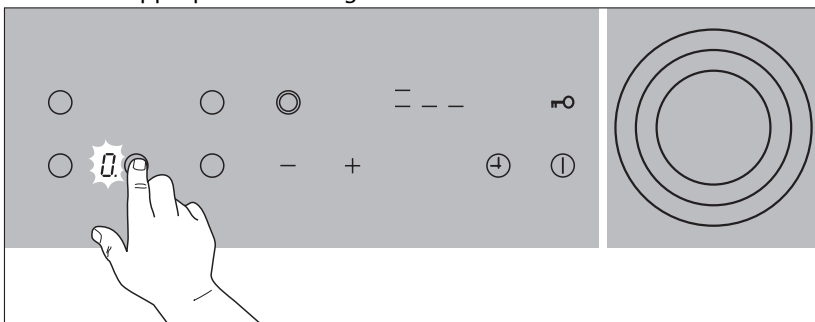

2. Set the required heat setting.

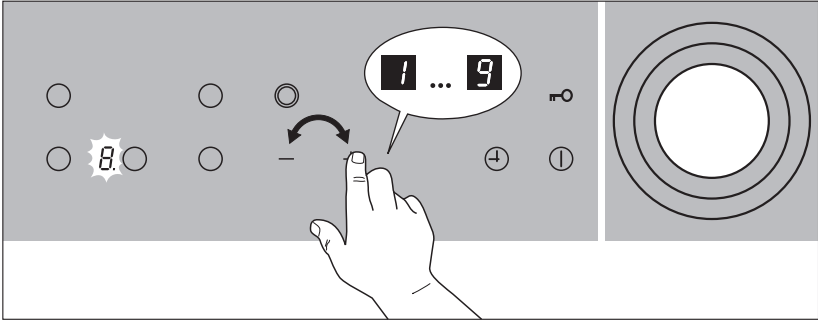

3. Touch the "booster" sensor field.

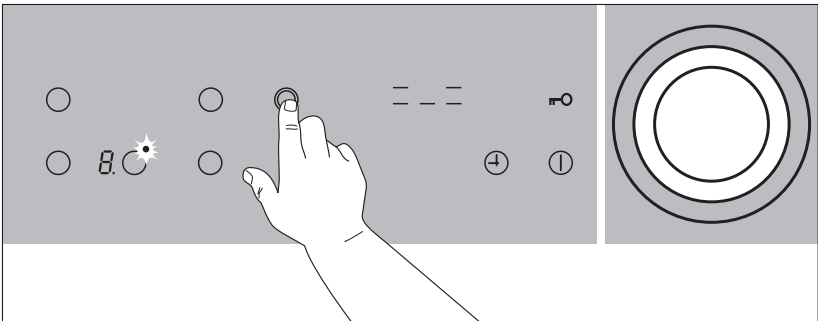

The middle ring is switched on. The control indicator under the symbol II is illuminated.

4. Touching the "booster" sensor field again activates the outer heating ring. The control indicator under symbol III is illuminated.

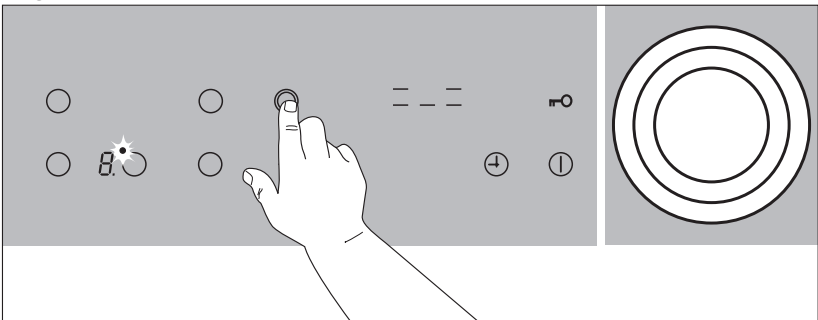

5. To switch off the outer heating rings touch the "booster" sensor field; the corresponding outer heating ring is switched off.

Switching the Casserole Zone On and Off

1. Select the appropriate cooking zone.

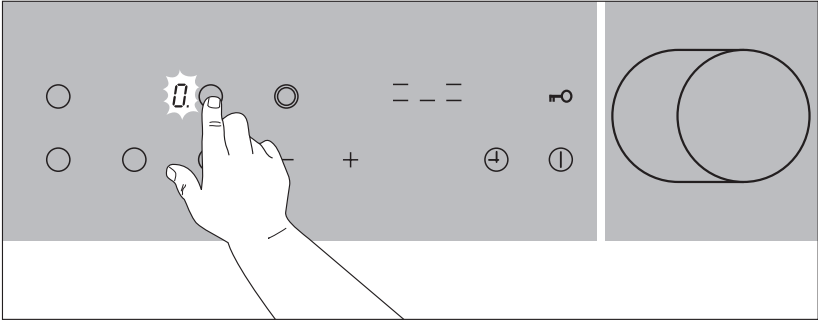

2. Set the required heat setting.

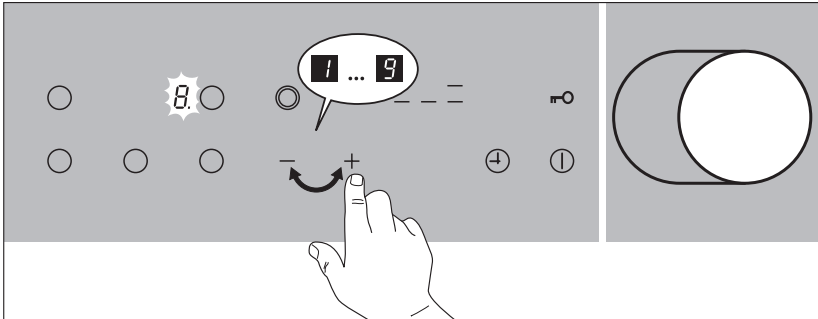

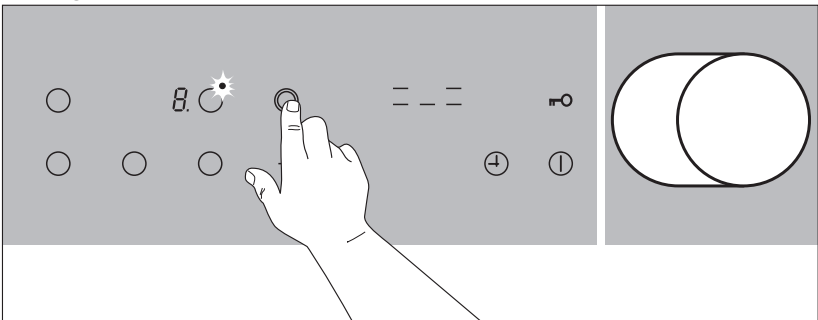

3. To switch the casserole zone on or off place your finger flat on the "booster" touch control sensor field, until the control indicator comes on or goes off.

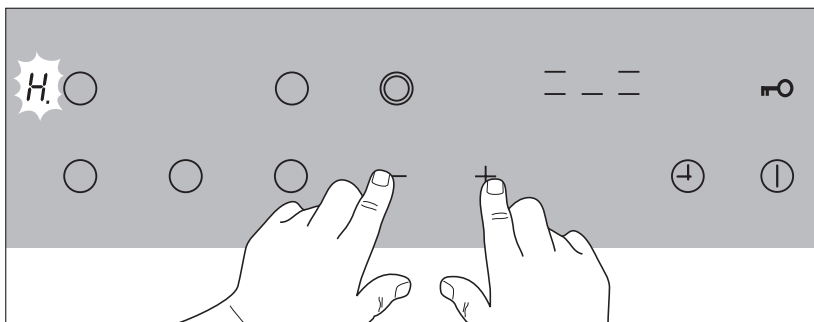

Switching off a Cooking Zone

1. Select the required cooking zone with the cooking zone sensor fields.
2. Touch sensor fields ⊕ and ⊖ simultaneously to switch off or turn sensor field ⊖ back to zero.







-  A cooking zone may only be switched off when the decimal point is on in the cooking zone display.

Residual Heat Indicator

When an individual cooking zone or the entire hob is switched off, any residual heat is shown with an  (for "Hot") in the digital display for the appropriate cooking zones.



Even after the cooking zone has been switched off, the residual heat indicator only goes out when the cooking zone is cold.

-  You can use the residual heat for melting and keeping food warm.
-  **Important!** As long as the residual heat indicator is illuminated, there is a risk of burns.
-  **Important!** If the power supply is interrupted the  symbol will also go out and information about residual heat will no longer be available. However, it may still be possible to burn yourself. This can be avoided by taking care when near the hob.

Cooking with the Automatic Warm up Function

All four of the hob's cooking zones can be controlled in nine stages and have an automatic warm up function:

- [1], lowest heat setting
- [9], highest heat setting
- [A], automatic warm up function

When you select the required heat setting using the ⊕ sensor field, the cooking zone will work for a specific time on full power and then switch automatically to the set heat setting.

The duration of the automatic warm up function depends on the heat setting selected.

Select the required cooking zone with the cooking zone sensor fields.

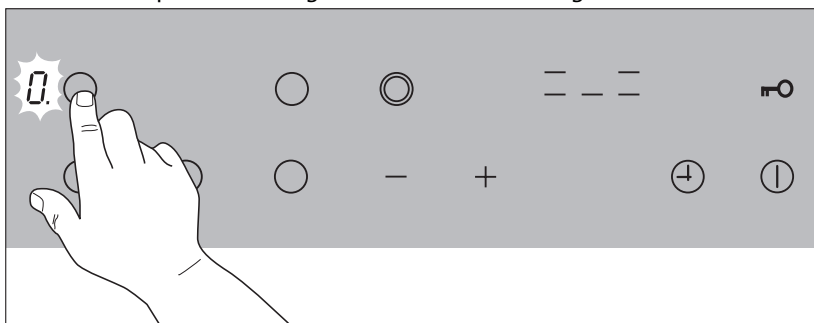

Touch sensor field ⊕ until it reaches the required heat [1] to [9]. The set heat setting will be displayed first. After five seconds [A] (= automatic warm up function) will replace the heat setting in the display. At the end of the warm up time the heat setting will be shown again.

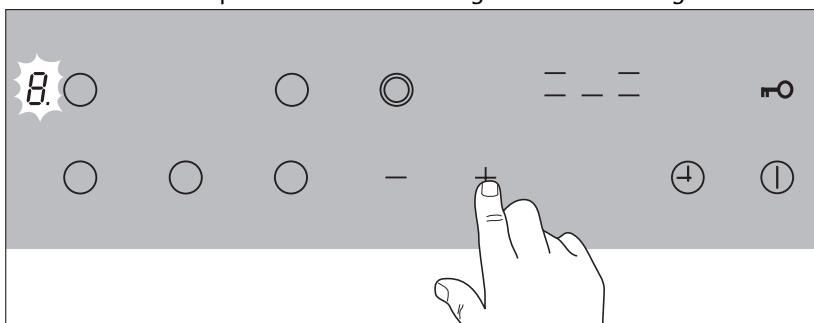

If during the automatic warm up function you select a higher setting, eg. from [3] to [5], the warm up time is adjusted to match. If you select a lower setting, the warm up time ends at once.



If you start cooking again on a cooking zone that is still warm, the automatic warm up function uses the residual heat. This saves time and energy.



If you again wish to switch on a cooking zone on which hot items are already standing, you should always select the required heat setting with the sensor field. In this way you can avoid making the food boil over as a result of the extra burst of heat from the automatic warm up.

Cooking without the Automatic Warm up Function

If you wish to use the cooking zone without automatic warm up, select the required heat setting with the sensor field.

1. Switch on the appliance and select the desired cooking zone using the cooking zone selection buttons.
2. Touch sensor field to select the required heat setting from to .

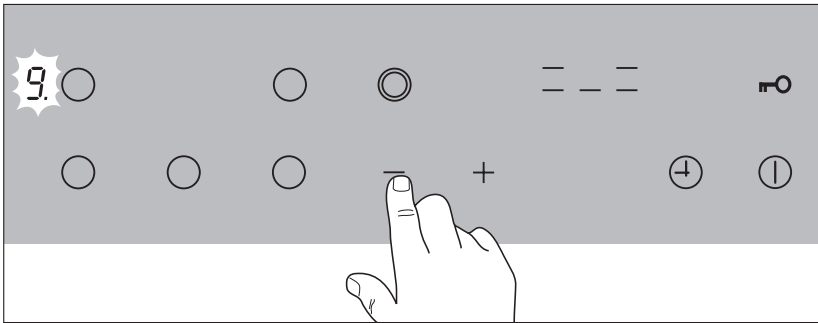

You can adjust the heat setting at any time using the and buttons, providing the cooking zone has been selected.

Switching off a cooking zone

1. Select the desired cooking zone using the cooking zone buttons.
2. Press the and buttons simultaneously to switch off.



When the rings are still hot cooking should be carried out without automatic warm up.

Locking/Unlocking the Control Panel

With the exception of the "On/Off" sensor field the control panel can be locked at any required time during cooking in order to prevent adjusting the settings such as when wiping over with a cloth. This function is also suitable as a child safety feature.

1. Touch the „lock“ sensor field until the control indicator comes on.

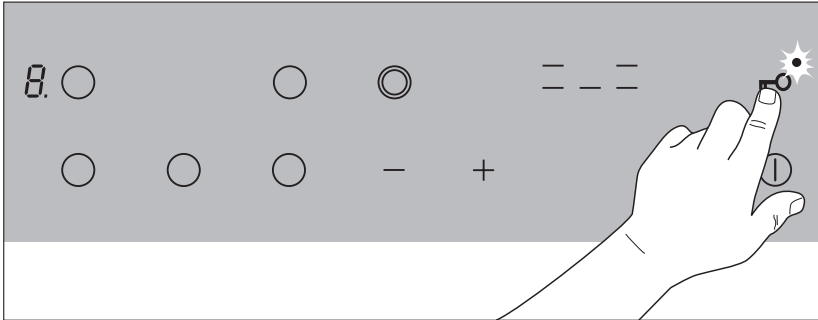



2. To release the lock touch the „lock“ sensor field again continuously until the control indicator goes out.





Child safety feature! If the hob is completely switched off using the "On/Off" sensor field while the lock is on, then the lock will still be active when the hob is switched on again. To reactivate the cooking zones, the locking function must be cancelled as described above.

Timer

A cooking duration can be set with the integrated timer for all cooking zones. When the end of the cooking duration is reached, the cooking zone switches itself off automatically.

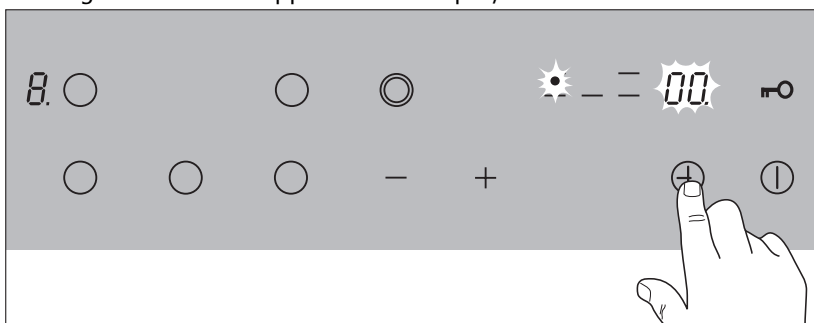
1. Using the cooking zone sensor field, select the required cooking zone and set the required heat setting.
2. Touch the TIMER  sensor field to activate the timer function for this cooking zone.  will appear in the display.



3. Using the  or  sensor fields set or adjust the required period of time until the zone is to switch off automatically (eg. 15 minutes).

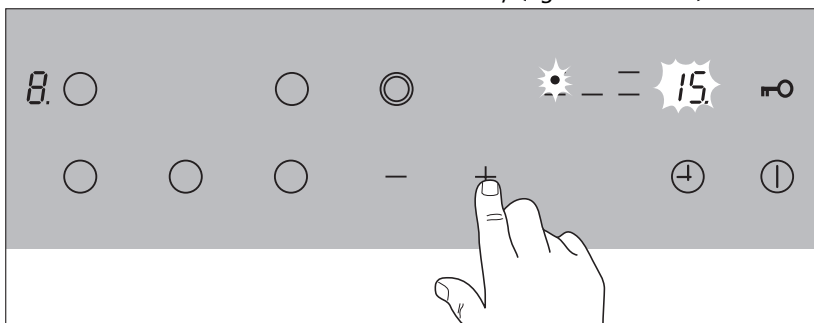

After a few seconds the timer will start automatically and will show how much time remains before it will switch off.

In addition, the "Timer active" display for the relevant cooking zone will light up.

At the end of the set cooking time, the cooking zone will switch off automatically and an acoustic signal will sound.

4. Touch the TIMER  sensor field to switch off the signal and control indicator.



To set the timer more quickly, leave your finger on the ⊕ or ⊖ sensor field until the required time is reached.

If the ⊖ sensor field is operated first, the time setting will begin at 99 minutes; if the ⊕ sensor field is operated first, the time setting will begin at 1 minute.

Displaying the remaining cooking time

If you select a cooking zone which is in timer mode, the cooking time still remaining appears in the timer display window.

Using the timer to measure short periods of time ("Minute Minder").



Important! None of the cooking zones should be set with the Timer!

1. Touch the "On/Off" sensor field for around two seconds.
The digital display □ flashes.
2. Touch the TIMER ⊗ sensor field to activate the Timer function.
3. Using the ⊕ or ⊖ sensor fields, set the desired length of time (for example, 20 minutes).
The Timer begins to run after a few seconds, and indicates the time remaining.
When the set time has elapsed, an audible signal is sounded.
4. Touch the TIMER ⊗ sensor field, to switch off the signal.

Ending the timer function prematurely

There are two ways of switching off the timer early:

Switching off the cooking zone and timer simultaneously

1. Select the desired cooking zone using the cooking zone buttons.
2. Touch the ⊕ and ⊖ buttons simultaneously: **The cooking zone and timer** will switch off.

Switching off the timer - leaving the cooking zone active

1. Select the desired cooking zone using the cooking zone buttons.
2. Touch the "Timer" button again.
3. Touch the ⊕ and ⊖ buttons simultaneously:
 - Only the **timer** will switch off.
 - The cooking zone will stay on.

Power Management

If a high heat setting (8 or 9) is set for the front left, rear right and front right cooking zones simultaneously, the hob control automatically brings about the optimal distribution of heating power. In this case the last cooking zone to be switched on takes priority and is allocated the selected heat setting 8 or 9. The automatic power management sets the remaining two cooking zones to heat setting 7. The heat setting displays for these two cooking zones display alternately the setting originally set (8 / 9) and 7.

The automatic warm up is not available for the front left, rear right and front right cooking zones if these three cooking zones are operated simultaneously. This means that if two of the rings are working in automatic warm up mode and the third ring is then also switched on, the automatic warm up will switch off automatically and the rings will be set to the selected heat setting. The 8 display shown in the display window changes to the set heat setting.

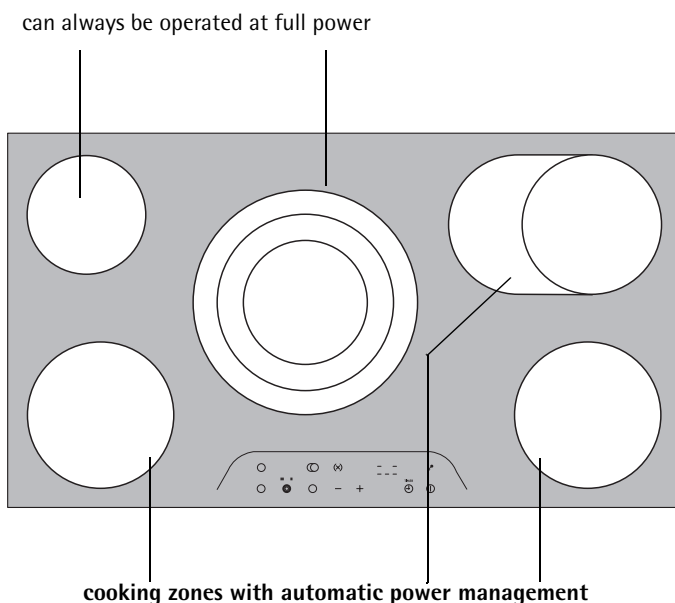

Example:

Cooking zone	Heat setting	Display
1. front left	9	7 and 9 alternately
2. rear right	9	7 and 9 alternately
3. front right	9	9
change front left	5	5
rear right	9	7 and 9 alternately
front right	9	9

Uses, Tables and Tips

Pans

The better the pan, the better the results.

- You can recognise good pans by their bases. The base should be as thick and flat as possible.
- Pay particular attention when buying new pans to the diameter of the base. Manufacturers often give only the diameter of the upper rim.
- Pots with aluminium or copper bases can cause metallic discolouring on the glass ceramic surface, which is very difficult or impossible to remove.
- Do not use cast iron pans or pans with a rough, burred or damaged base. This can produce permanent scratching if the pan is slid across the surface.
- When cold, pan bases are normally bowed slightly inwards (concave). They should never be bowed outwards (convex).
- If you wish to use special types of pan (e.g. a pressure cooker, simmering pan, wok, etc.), please observe the manufacturer's instructions.

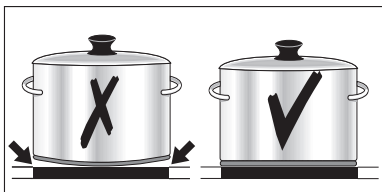

Energy saving tips

You can save valuable energy by observing the following points:

- Always position pots and pans before switching on the cooking zone.
- Dirty cooking zones and pan bases increase power consumption.
- Whenever possible always position the lids firmly on pots and pans to cover completely.
- Switch off the cooking zones before the end of the cooking time to use the residual heat such as to keep foods warm or for melting.
- The base of the pan should be the same size as the cooking zone.
- Using a pressure cooker reduces cooking times by up to 50%.

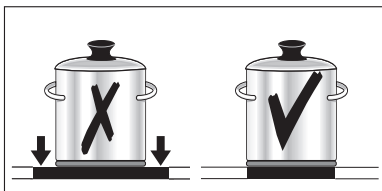
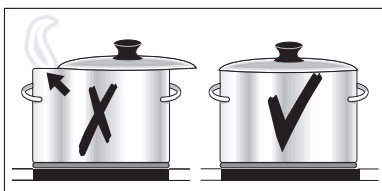

Advice on Cooking with and without Automatic Warm up



The automatic warm up function is suitable for:

- dishes that start off cold, are heated up at high power and do not need to be continually watched when cooking on the selected heat setting,
- dishes that are put in a hot frying pan.

The automatic warm up function is not suitable for:

- goulash, beef olives and similar braised dishes that need continual turning until browned correctly, have liquid added and are then braised until cooked,
- dumplings, pasta dishes with large amounts of liquid,
- cooking with pressure cookers,
- very large quantities of soup/stew with more than 2 litres of liquid.

General notes:

- When cooking without the automatic warm up function, we recommend the use of a high heat setting to warm up the food (using the  button) and then leave the dish to finish cooking at an appropriate lower heat setting.
- Take special note of the results when you first use the appliance! You can then decide which heat setting is the best for "your dishes" in the "quantities you are accustomed to preparing" with "your pans". You will then quickly appreciate the advantages of the automatic function and will feel relaxed about using your new hob.
- You can use the  heat setting for keeping food warm.

Typical Heat Settings

The information given in the following tables is for guidance. The heat setting required for cooking depends on the quality of the pans and on the type and quantity of food.

Switch Setting	Automatic Warm Up Time ¹⁾ (Min.)	Cooking Process	Examples of Usage
9		Warming up Frying Deep-fat frying	Warming up large amounts of liquid, boiling pasta, browning meat, (browning goulash, pot-roast)
8	4.5	Fast frying	Steaks, pieces of loin, potato fritters, fried sausages, pancakes, doughnuts
7	3.5		
6	2.5	Frying	Schnitzel/cutlets, liver, fish, rissoles, fried eggs
5	8.5	Boiling	Boiling up to 1.5 l liquid, potatoes, vegetables
4	6.5		
3	4.8	Steaming Sautéing Poaching	Steaming and sautéing small quantities of vegetables, cooking rice and milk-based dishes
2	3.0		
1	1.0	Keeping warm melting	Keeping foods warm, melting butter, dissolving gelatine, melting chocolate

1) When cooking without the automatic warm up function, the warm up time can be selected as required.



When heating up or frying, we recommend using the warm up setting "9" and then continue cooking foods that require longer cooking times at an appropriate lower heat setting.

Cleaning and Care

Hob



Important: Cleaning agents must not come into contact with the **hot** ceramic glass surface! All cleaning agents must be removed with plenty of clean water after cleaning because they can have a caustic effect when the rings are next heated!

Do not use any aggressive cleaners such as grill or oven sprays, coarse scourers or abrasive pan cleaners.



Clean the ceramic glass surface after each use when it is warm to the touch or cold. This will avoid spillages becoming burnt on.

Remove scale and water marks, fat spots and discolouration with a metallic shimmer using a commercially available ceramic glass or stainless steel cleaner.

Light Soiling

1. Wipe the ceramic glass surface with a damp cloth and a little washing up liquid.
2. Then rub dry with a clean cloth. Remnants of cleaner must not be left on the surface.
3. Thoroughly clean the entire ceramic glass cooking surface once a week with a commercially available ceramic glass or stainless steel cleaner.
4. Then wipe the ceramic glass surface using plenty of clean water and rub dry with a clean fluff-free cloth.

Stubborn Soiling

1. To remove food that has boiled over or stubborn splashes, use a glass scraper.
2. Place the glass scraper at an angle to the ceramic glass surface.
3. Remove soiling by sliding the blade.



You can obtain glass scrapers and ceramic glass cleaners from specialist retailers.

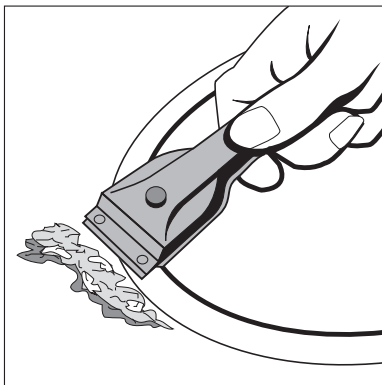



Problem Dirt

1. Remove burnt-on sugar, melted plastic, aluminium foil or other meltable materials with a glass scraper **immediately and while still hot**.



Important: There is a risk of burning yourself when the glass scraper is used on a hot cooking zone!

2. Then clean the hob normally when it has cooled down.



If the cooking zone on which something has melted has already cooled down, warm it up again for cleaning.

Scratches or dark marks on the ceramic glass surface, caused for example by a pan base with sharp edges, cannot be removed. However, they do not impair the function of the hob.

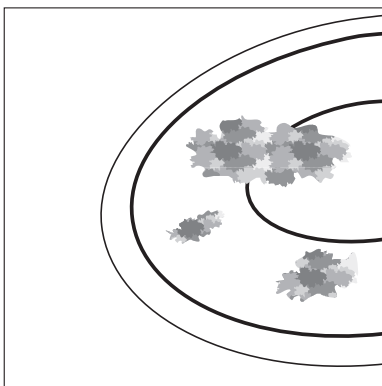

Hob Frame



Important! Do not put vinegar, lemon-juice or scale removers on the hob frame, otherwise dull spots will appear.

1. Wipe the frame with a damp cloth and a little washing up liquid.
2. Soften dried dirt with a wet cloth. Then wipe off and rub dry.

What to do if ...

Rectifying faults

It is possible that faults have been caused by a minor error, which you can correct yourself with the help of the following instructions. Do not attempt any further repairs if the following instructions do not help in each specific case.



Warning! Repairs to the appliance are only to be carried out by approved service engineers. Improperly effected repairs may result in considerable risk to the user. If your appliance needs repairing, please contact your specialist dealer or customer service.

What to do if ...

.... the cooking zones do not work?

Check whether

- the mains fuse (fuse box) is intact or the circuit breaker (at the household fuse box) has tripped. If the circuit breaker trips or the fuse blows several times, please call an approved electrician.
- the appliance has been properly switched on,
- the control indicators in the control panel are on,
- the correct cooking zone has been switched on,
- the cooking zones are set to the desired heat setting for cooking,
- the cooking zones have been switched off by the safety switch (see section "Safety functions").

.... the cooking zones cannot be switched on?

Check whether

- the control panel is locked (see section "Locking the Control Panel").
- more than 10 seconds have elapsed between operating the On/Off button and switching on the desired cooking zone, (see section "Switching on the Appliance").
- the sensor fields are partially covered by a damp cloth or with liquid.

.... the display suddenly changes to or for residual heat?

Check whether

- the On/Off button has been operated accidentally.
- the sensor fields are partially covered by a damp cloth, liquid or similar
- the safety switch has been activated.

.... after switching off the cooking zones, neither  nor  for residual heat appears in the display?

Check whether

- the cooking zone was only used for a short period and is therefore not hot enough.

If the cooking zone is hot, call the customer service.

.... a cooking zone cannot be switched off?

Check whether

- the sensor fields are partially covered by a damp cloth or liquid.
- the lock is activated.

.... a cooking zone cannot be switched on?



Check whether

- the lock is activated.

....  is shown in the display?

Check whether the cooking zone has been overheated.

This indicator lights up to show overheating, electronic faults or for safety reasons.

.... the display alternates between two heat settings, e.g.,  and  ?

Check whether the front left, rear right and front right cooking zones are being used simultaneously and read the section "Power Management".

If you call in customer service to resolve a problem caused by incorrect operation of the appliance, the customer service engineer's visit will not be free of charge, even during the warranty period.

Installation Instructions



Important! The new appliance may only be installed and connected by **qualified personnel**.

Please observe this instruction, otherwise the warranty will not cover any damage that may occur.

Technical Data

Appliance dimensions

Width	890 mm
Depth	501 mm
Height	47 mm

Worktop cut-out dimensions

Width	880 mm
Depth	490 mm
Corner radius	R5

Cooking rings

Position	Diameter	Power
Front left	180 mm	1800 W
Rear left	145 mm	1200 W
Centre	145/210/275 mm	1050/1950/2700 W
Rear right	170/265 mm	1400/2200 W
Front right	180 mm	1800 W

Connection voltage 230 V ~ 50 Hz

Maximum connected load power 7,9 kW

Regulations, Standards, Directives

This appliance meets the following standards:

- EN 60 335-1 and EN 60 335-2-6
relating to the safety of electrical appliances for household use and similar purposes and
- EN 60350, or DIN 44546 / 44547 / 44548
relating to the operating features of electric cookers, hobs, ovens, and grills for household use.
- EN 55014-2
- EN 55014
- EN 61000-3-2
- EN 61000-3-3
- relating to basic requirements for electro-magnetic compatibility protection (EMC).



This appliance complies with the following EU Directives:

- 73/23/EWG dated 19.02.1973 (Low Voltage Directive)
- 89/336/EWG dated 03.05.1989 (EMC Directive including Amending Directive 92/31/EWG).



Safety Instructions for the Installer

- A device must be provided in the electrical installation which allows the appliance to be disconnected from the mains at all poles with a contact opening width of at least 3 mm. Suitable isolation devices include line protecting cut-outs, fuses (screw type fuses are to be removed from the holder), earth leakage trips and contactors.
- In respect of fire protection, this appliance corresponds to EN 60 335-2-6. This type of appliance may be installed with a high cupboard or wall on one side.
- Drawers may not be fitted underneath the hob.
- The installation must guarantee shock protection.
- The kitchen unit in which the appliance is fitted must satisfy the stability requirements of DIN 68930.
- For protection against moisture, all cut surfaces are to be sealed with a suitable sealant.
- On tiled work surfaces, the joints in the area where the hob sits must be completely filled with grout.
- On natural, artificial stone, or ceramic tops, the snap action springs must be bonded in place with a suitable artificial resin or mixed adhesive.
- Ensure that the seal is correctly seated against the work surface without any gaps. Additional silicon sealant must not be applied; this would make removal more difficult when servicing.
- The hob must be pressed out from below when removed.

Electrical Connection

Before connecting, check that the nominal voltage of the appliance, that is the voltage stated on the rating plate, corresponds to the available supply voltage. The rating plate is located on the lower casing of the hob.

The heating element voltage is AC230V~. The appliance also works perfectly on older networks with AC220V~.

The hob is to be connected to the mains using a device that allows the appliance to be disconnected from the mains at all poles with a contact opening width of at least 3 mm, eg. automatic line protecting cut-out, earth leakage trips or fuse.

A type H05W-F cable or one with a higher grade must be used as the mains connecting cable.

The connection must be carried out as shown in the diagram. The connecting links should be fitted according to the appropriate connection diagram. The earth lead is connected to terminal . The earth lead must be longer than leads carrying electric current.

The cable connections must be made in accordance with regulations and the terminal screws tightened securely.

Finally, the connecting cable is to be secured with the mains cable cleat and the covering closed by pressing firmly (lock into place).

Before switching on for the first time, any protective foil or stickers must be removed from the glass ceramic surface.



Once connected to the mains supply check that all cooking zones are ready for use by briefly switching each on in turn at the maximum setting.

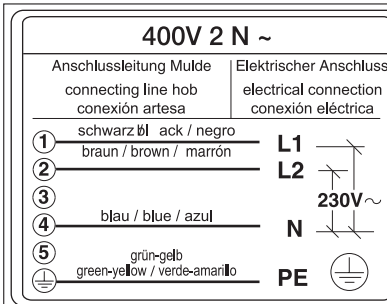

330 17 84-01

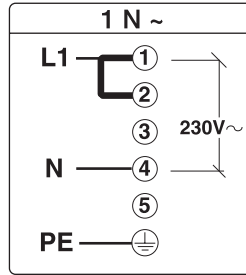
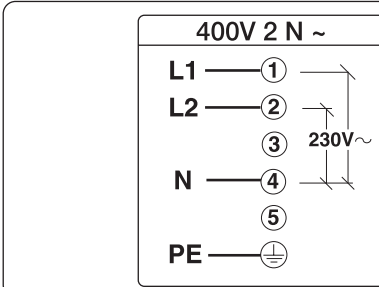
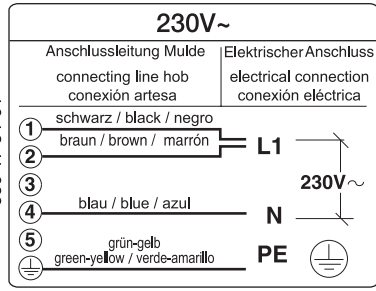

330 17 84-02

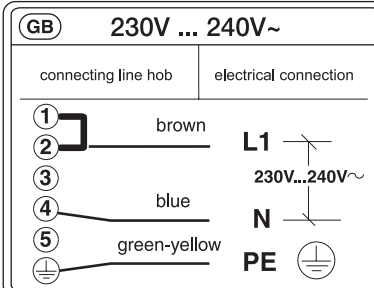

330 17 84-03

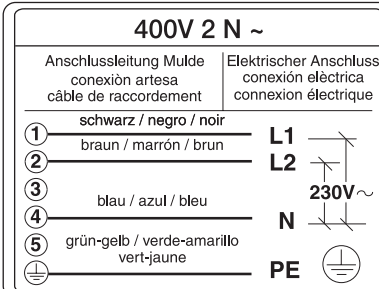
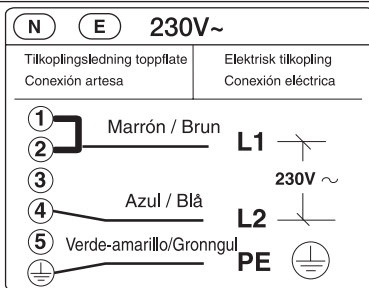

330 17 84-04

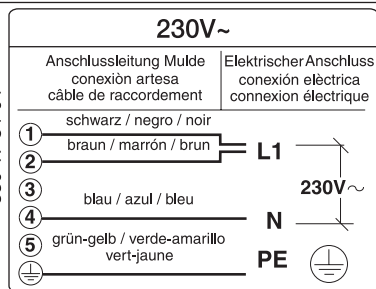

Service

In the "What to do if ..." section a number of malfunctions are listed that you can rectify yourself. Look there first if a fault occurs.

Is it a technical fault?

If so, please contact your customer service centre. (You will find addresses and telephone numbers in the section "Customer Service Centres".)

Always prepare in advance for the discussion. This will make diagnosis of the problem easier and also make it easier to decide if a customer service visit is necessary:

Please make a note of the following information as accurately as possible:

- What form does the fault take?
- Under what circumstances does the fault occur?

Prior to the telephone call it is important that you make a note of the following appliance code numbers that are given on the rating plate:

- model description,
- PNC code (9 digits),
- S No code (8 digits).

We recommend that you record the code numbers here so that you always have them to hand:

Model:

PNC:

S-No:

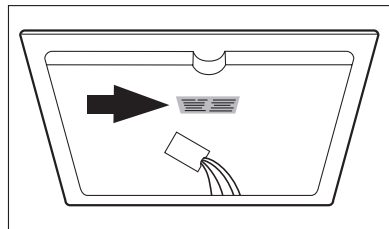

When do you incur costs even during the warranty period?

- if you could have remedied the fault yourself using the fault table (see section "What to do if ..."),
- if the customer service technician has to make several journeys because he was not provided with all the relevant information before his visit and therefore, for example, has to fetch spare parts. These multiple trips can be avoided if you prepare your phone call as described above.

Montage / Assembly

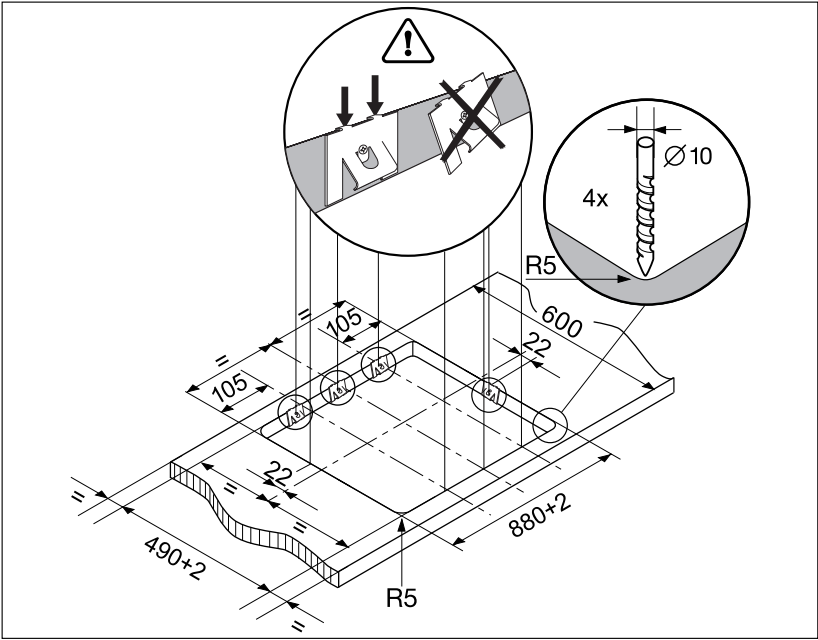
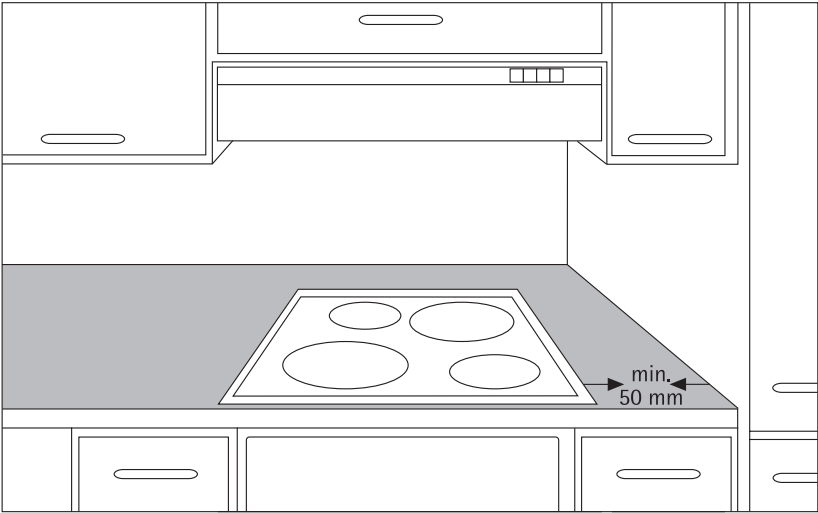

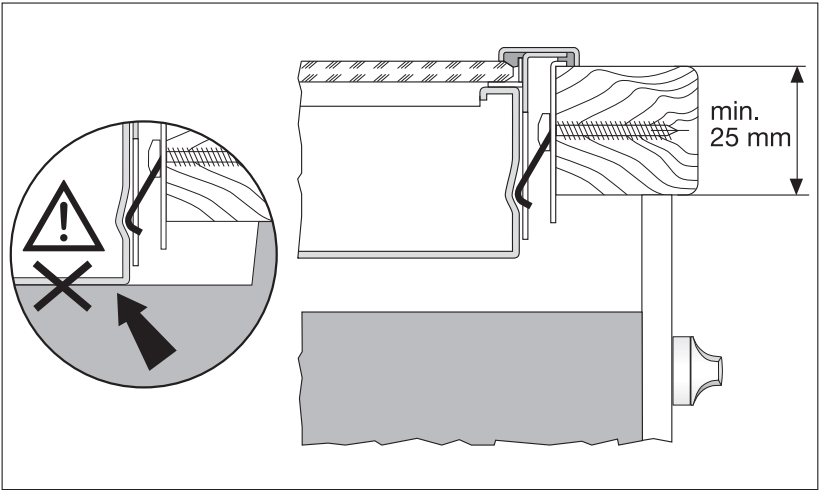
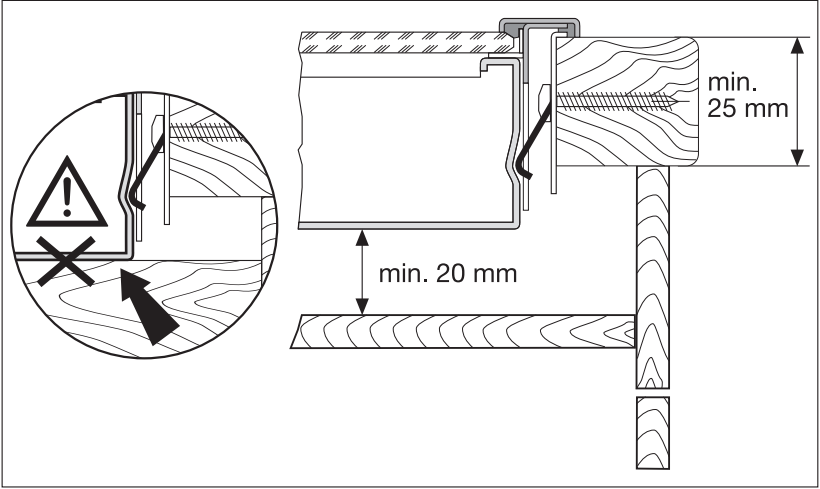

 **From the Electrolux Group. The world's No. 1 choice.**

The Electrolux Group is the world's largest producer of powered appliances for kitchen, cleaning and outdoor use. More than 55 million Electrolux Group products (such as refrigerators, cookers, washing machines, vacuum cleaners, chain saws and lawn mowers) are sold each year to a value of approx. USD 14 billion in more than 150 countries around the world.

Hier Typenschild aufkleben

(nur für Werk)

AEG Hausgeräte GmbH
Postfach 1036
D-90327 Nürnberg

<http://www.aeg.hausgeraete.de>

© Copyright by AEG

319 559 000-A-250203-03

Änderungen vorbehalten
Subject to change without notice
Sous réserve de modifications
Wijzigingen voorbehouden