

ME6008M Batch Monitor Printer Driver Unit

FEATURES

- Prints QA batch totals automatically (programmable delay), or manually.
- Internally logs 500 batch events, downloadable to your laptop/PC via optional front-access DB9 RS232 connector (that also comes with a RS232-to-USB adapter).
- Monitors up to 8 channels of water and admixture.
- Channel units in millilitres or Litres.
- Batch number ID, time and date.
- Real time clock.
- Grand Totals and batch history can also be printed (or dumped to a PC) on demand.
- User-friendly menu tree.
- Programmable pulse scaling (K-Factor).
- IP65-rated touchpad.



The Manu Electronics ME6008M has been designed to interface from Batch Controllers to loggers or serial printers, and will provide automatic end-of-batch printing and datalogging of 500 batch events. All records are time-stamped from the unit's Real Time Clock.

The unit is operated from a front panel keypad with a LCD 2-line display. Selections are made from a four-function "soft-key" tree structured menu.

SAMPLE PRINTOUTS

ME6008M Batch Monitor Printer Driver



WIDE
dot matrix tractor feed
LX300+II printer
204mm wide printout
80 characters

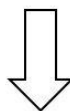

or

COMPACT
dot matrix paper roll
DP8340 printer
84mm wide printout
40 characters

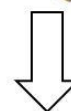

	DATE	TIME	CH:1	CH:2	CH:3	CH:4	CH:5	CH:6	CH:7	CH:8
			L	L	mL	mL	mL	mL	L	L
B-0001	20-06-11	10:34	000000	000349	000000	000000	000000	000000	000000	000000
B-0002	20-06-11	10:34	000000	000000	000450	000000	000000	000000	000000	000000

BATCH No	DATE	TIME	CH - 4
CH - 1	CH - 2	CH - 3	CH - 8
CH - 5	CH - 6	CH - 7	
B - 0001	21 - 03 - 11	10 : 48	
0 0 0 0 1 0 m L	0 0 0 0 0 5 L	0 0 0 0 0 0 m L	0 0 0 0 0 0 L
0 0 0 0 1 0 L	0 0 0 0 0 9 0 m L	0 0 0 0 0 0 0 L	0 0 0 0 0 0 0 m L
B - 0002	21 - 03 - 11	10 : 49	
0 0 0 0 7 0 0 m L	0 0 0 0 0 2 L	0 0 0 0 8 0 m L	0 0 0 0 0 0 L
0 0 0 0 0 4 L	0 0 0 0 0 8 0 m L	0 0 0 0 0 4 L	0 0 0 0 0 0 m L

SETUP

- 1 The printer supplied by ManuFlo will have its serial port settings already configured as described on Page 8. If using another serial printer then check, and if necessary adjust, its serial port settings (refer to the printer's User Manual).
- 2 Ensure that power is off to the serial printer, to the ME6008M, and to your existing Batch Controllers from which the flowmeter signals will be obtained.
- 3 Connect the supplied RS232 Communication Cable (see Page 8) between the ME6008M's DB9 RS232 port and the DB25 port of the LX300+II or DP8340 serial printer (or another serial printer).
- 4 Parallel from the back of your existing Batch Controllers (or ME2000, or flowmeters), to connect 0 Volts and Pulse signals from flowmeters to the ME6008M (see pages 3 and 4).

IMPORTANT:

If using a paddlewheel-type flowsensor, then connect the flowsensor to either Channel 1 or to Channel 2 only of the ME6008M, as these channels have specialised inputs for paddlewheel water measurement pulses.

- 5 Connect power to the ME6008M:
 - if an ac-powered unit, then connect 240 vac mains power to the ME6008M;
 - if a DC-powered unit, then connect 12 VDC power.
- 6 Turn power on to the serial printer, and to the ME6008M.
The printer "online" indicator will come on.
The ME6008M will show the power on screen for about 3 seconds, then will show Screen 1 (see the Menu Tree section on page 5).
- 7 Ensure that the correct printer model is selected (menu screen 11B). This is usually pre-configured by ManuFlo.
- 8 Parameters including input pulse scaling are factory set to 1 pulse per unit (L).
Parameters including pulse scaling can be reprogrammed to suit your specific installation (see menus 10A and 10B) e.g.
if using 25mm MES25 admixture flowmeter, set pulses/unit to 0555.00 and units to Litres
if using 50mm RPFS-P water flowmeter, set pulses/unit to 0020.00 and units to Litres.
- 9 Power up the Batch Controllers (or ME2000, or flowmeters), and perform normal batching operations. At completion of each batch (after a programmable delay time), another record will print, logging the batch.

IMPORTANT: PRINT MODE

For the ME6008M to automatically print out batch quantities, the RUN key must be selected. The unit is then in Count Mode (Screen 2 on the Menu Tree diagram on Page 5).

To Read Batch Log via a Personal Computer (PC), using the PC serial port:

To read the entire batch log via a PC:

- connect a communications cable (see page 8) between the ME6008M serial port and the PC's port (using the serial to USB adapter if necessary).
- start HyperTerminal software on the PC. HyperTerminal is supplied as a part of Windows up to Windows XP, or can be downloaded from the Internet, at sites such as:
<http://www.hilgraeve.com/hyperterminal-trial/> , <http://hyperterminal-private-edition.findmysoft.com/> ,
http://download.cnet.com/HyperTerminal-Private-Edition/3000-2155_4-10966768.html
- ensure the PC's serial port settings are as described page 8.
- ensure printer is switched off to avoid the event log also printing out on the printer.

On the ME6008M, go to Screen 5 "PRINT FLOW HIST?" (see page 5) and press ALL, and the ME6008M will dump the batch log to the PC.

CONNECTION DIAGRAM - TO MANUFLO BATCH CONTROLLERS

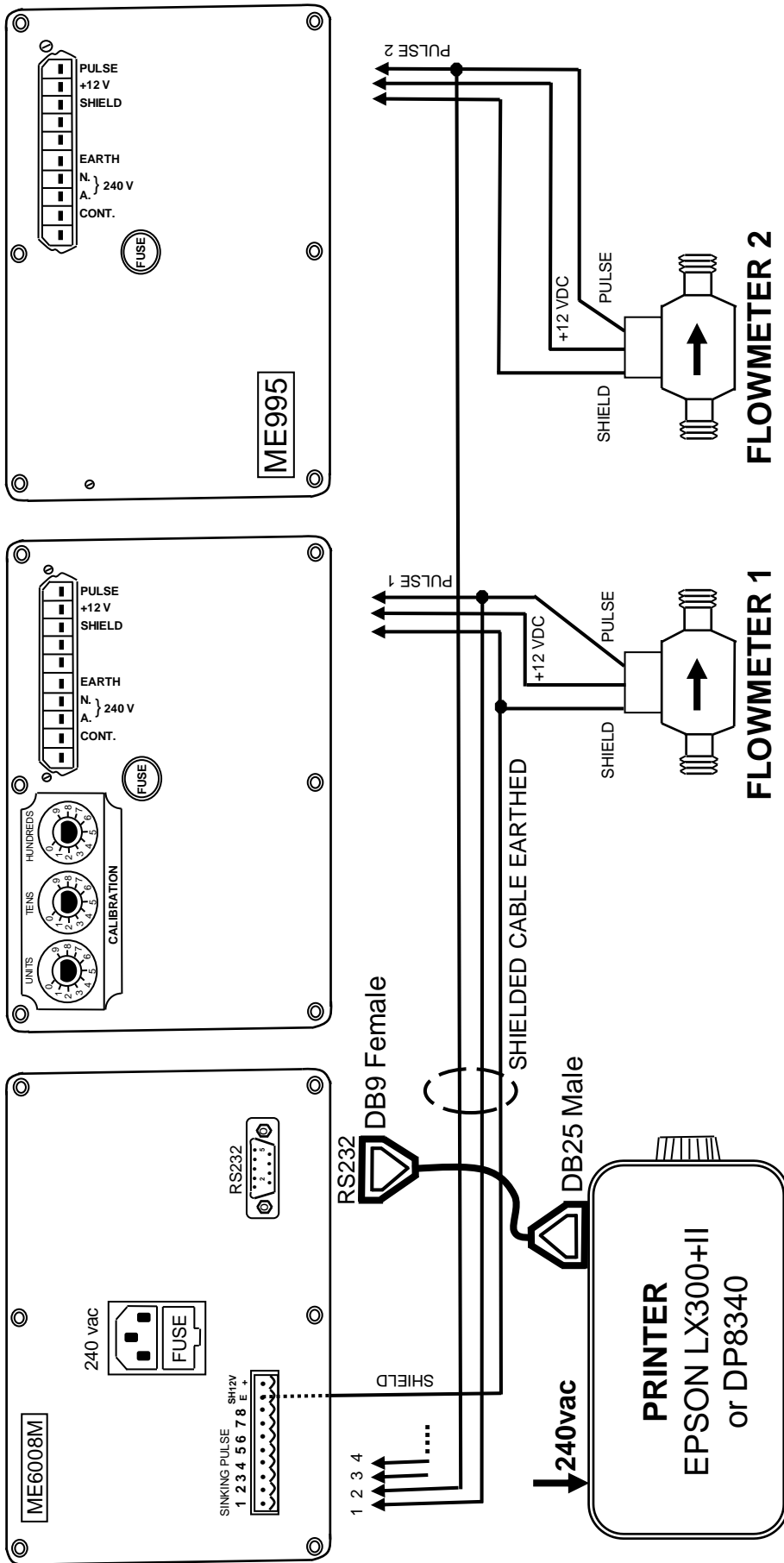

The flowmeter PULSE and 0 V are paralleled from the back of the Batch Controllers to the ME6008M.

ME2008 2-channel module

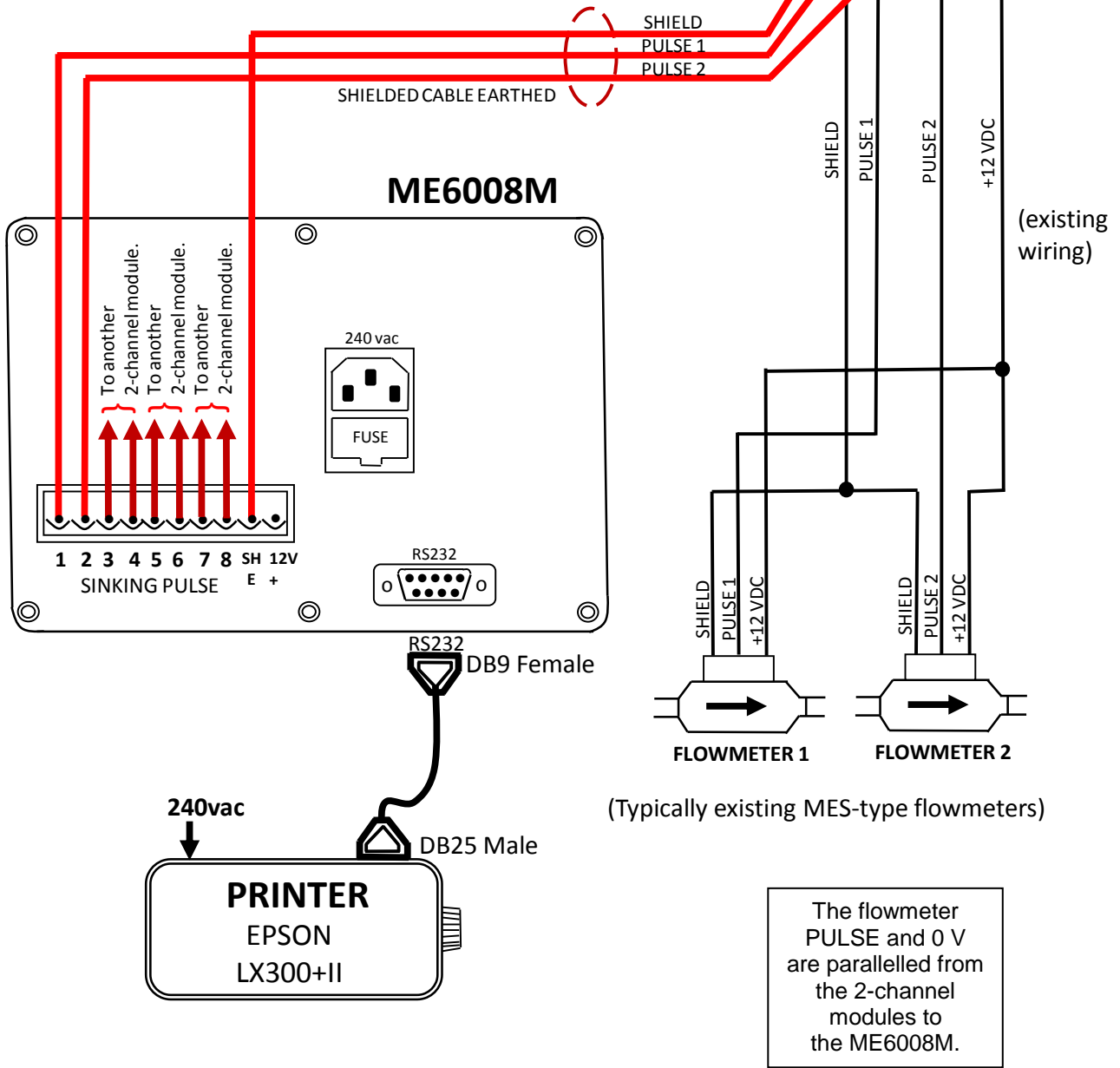
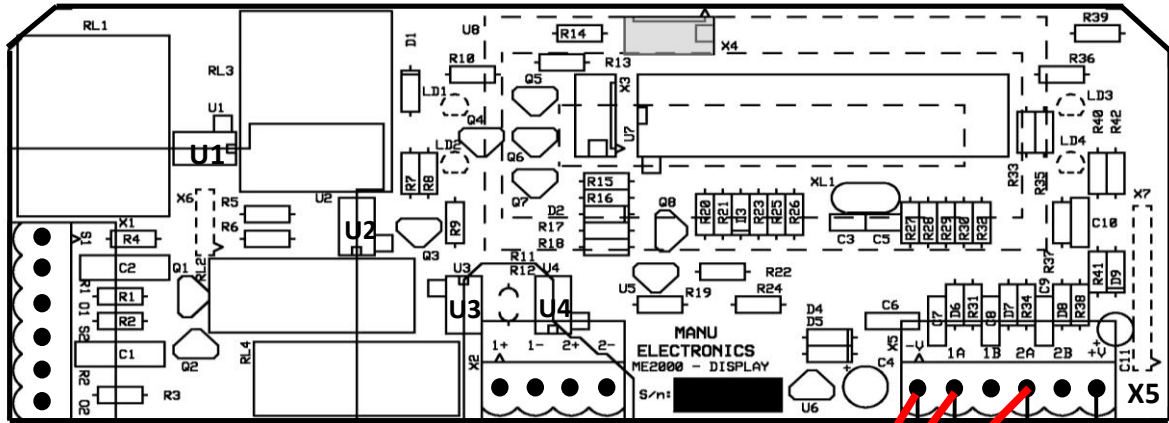

MENU TREE

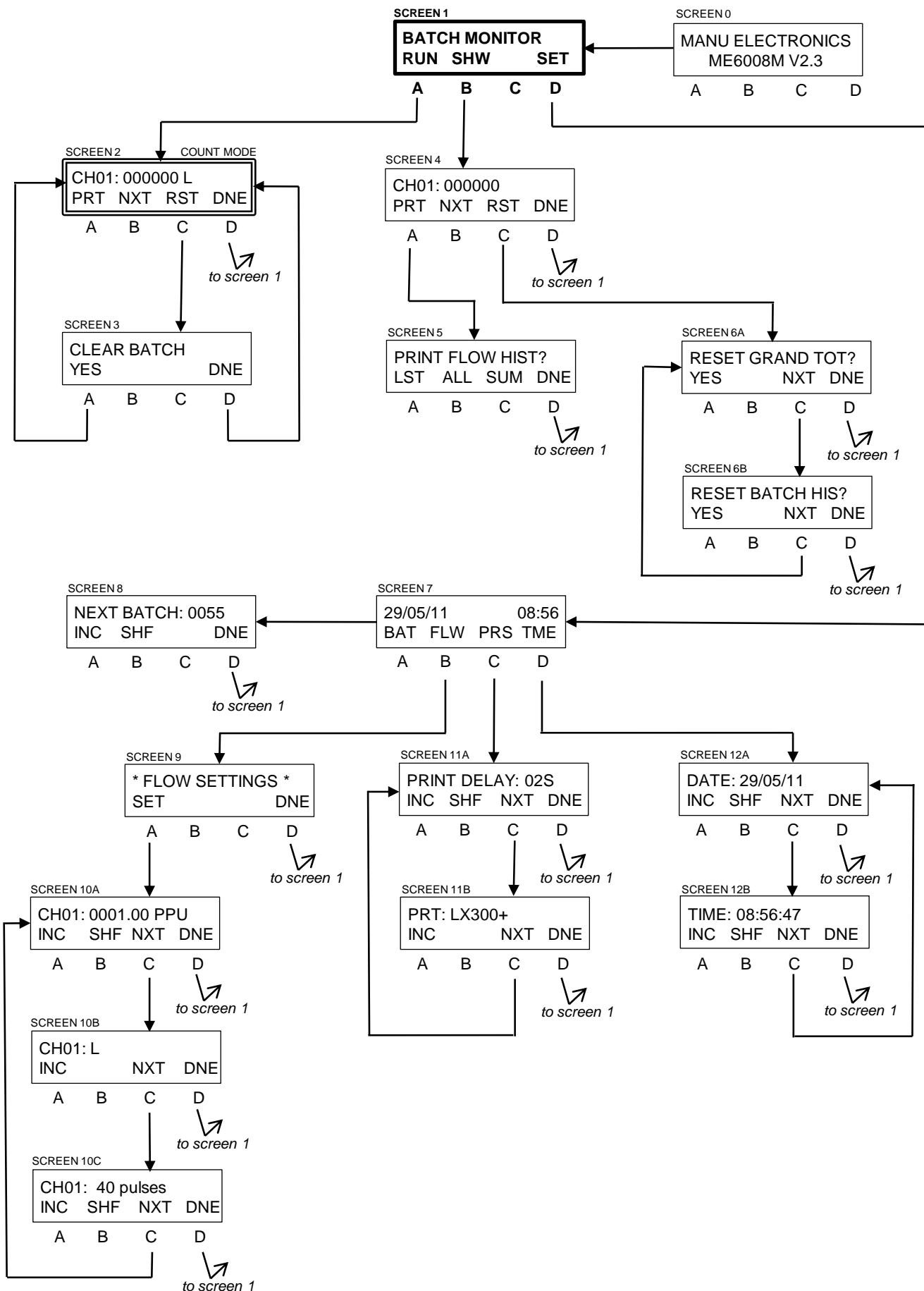

OPERATING INSTRUCTIONS

SCREEN 0: POWER-ON SCREEN.

- LASTS APPROXIMATELY 3 SECONDS. GIVES CURRENT FIRMWARE VERSION.

SCREEN 1: MAIN MENU

- PRESS RUN TO ENABLE COUNTING TO COMMENCE.
- PRESS SHW TO DISPLAY THE CURRENT GRAND TOTALS FOR EACH CHANNEL.
- PRESS SET TO CONFIGURE THE BATCH MONITOR.

SCREEN 2: COUNT MODE

- PRESS PRT TO PRINT THE CURRENT BATCH DATA.
- PRESS NXT TO DISPLAY THE NEXT CHANNEL.
- PRESS RST TO CLEAR THE CURRENT BATCH DATA.
- PRESS DNE TO RETURN TO THE PREVIOUS SCREEN.

SCREEN 3: CLEAR BATCH

- PRESS YES TO CLEAR THE CURRENT BATCH DATA ONLY.
- PRESS DNE TO RETURN TO THE PREVIOUS SCREEN.

SCREEN 4: SHOW CURRENT GRAND TOTALS

- PRESS PRT TO ENABLE PRINTING.
- PRESS NXT TO DISPLAY THE NEXT CHANNELS GRAND TOTAL.
- PRESS RST TO CLEAR EITHER THE GRAND TOTALS OR BATCH HISTORY
- PRESS DNE TO RETURN TO THE PREVIOUS SCREEN.

SCREEN 5: PRINT FLOW HISTORY

- PRESS LST TO PRINT THE LAST BATCH RECORDED
- PRESS ALL TO PRINT THE TOTAL BATCH HISTORY RECORDED.
- PRESS SUM TO PRINT THE GRAND TOTALS.
- PRESS DNE TO RETURN TO SCREEN 1.

SCREEN 6A: RESET GRAND TOTALS

- PRESS YES TO RESET THE GRAND TOTALS.
- PRESS NXT TO RESET THE BATCH HISTORY.
- PRESS DNE TO RETURN TO SCREEN 1.

SCREEN 6B: RESET BATCH HISTORY

- PRESS YES TO RESET THE BATCH HISTORY.
- PRESS NXT TO RESET THE GRAND TOTALS.
- PRESS DNE TO RETURN TO SCREEN 1.

SCREEN 7: CONFIGURE THE BATCH MONITOR

- PRESS BAT TO ENTER THE NEXT BATCH NUMBER REQUIRED.
- PRESS FLW TO ENTER THE K FACTORS FOR EACH CHANNEL.
- PRESS PRS TO ENTER THE PRINT DELAY OR PRINTER MODEL.
- PRESS TME TO ENTER THE DATE OR TIME.

SCREEN 8: ENTER BATCH NUMBER

- THE UNDERScore INDICATES WHICH DIGIT IS CURRENTLY SELECTED.
- PRESS INC TO INCREMENT THE DIGIT CURRENTLY SELECTED.
- PRESS SHF TO MOVE THE UNDERScore TO THE NEXT DIGIT.
- PRESS DNE TO RETURN TO SCREEN 1.

SCREEN 9: CHANGE FLOW SETTINGS (OR K-FACTOR)

- PRESS SET TO SET THE K-FACTOR FOR EACH CHANNEL (see Table 2 on Page 8).
- PRESS DNE TO RETURN TO SCREEN 1.

SCREEN 10A: ENTER THE K-FACTOR FOR EACH CHANNEL

- THE UNDERScore INDICATES WHICH DIGIT IS CURRENTLY SELECTED.
- PRESS INC TO INCREMENT THE DIGIT CURRENTLY SELECTED.
- PRESS SHF TO MOVE THE UNDERScore TO THE NEXT DIGIT.
- PRESS NXT TO SELECT CHANNEL UNIT (L or mL).
- PRESS DNE TO RETURN TO SCREEN 1.

SCREEN 10B: ENTER THE UNIT FOR EACH CHANNEL

- PRESS INC TO SELECT L (Litres) or mL (milliliters).
- PRESS NXT TO GO TO THE NEXT CHANNEL.
- PRESS DNE TO RETURN TO SCREEN 1.

SCREEN 10C: PULSE THRESHOLD BEFORE PRINTING A BATCH (default is 40 pulses)

- PRESS INC TO INCREMENT THE DIGIT CURRENTLY SELECTED.
- PRESS SHF TO MOVE THE UNDERScore TO THE NEXT DIGIT.
- PRESS NXT TO GO TO THE NEXT CHANNEL.
- PRESS DNE TO RETURN TO SCREEN 1.

SCREEN 11A: ENTER THE PRINT DELAY

- THE PRINT DELAY IS THE TIME OF INACTIVITY ON ALL CHANNELS THAT INDICATES THE END OF A BATCH.
- IT CAN BE SET FROM 2 TO 99 SECONDS.
- PRESS INC TO INCREMENT THE DIGIT CURRENTLY SELECTED.
- PRESS SHF TO MOVE THE UNDERScore TO THE NEXT DIGIT.
- PRESS NXT TO ENTER PRT (PRINTER MODEL).
- PRESS DNE TO RETURN TO SCREEN 1.

SCREEN 11B: ENTER THE PRINTER MODEL

- PRESS INC TO SELECT EITHER THE LX300+II OR THE DP8340 PRINTER.
- PRESS NXT TO RETURN TO SCREEN 11A.
- PRESS DNE TO RETURN TO SCREEN 1

SCREEN 12A: ENTER THE DATE

- THE UNDERScore INDICATES WHICH DIGIT IS CURRENTLY SELECTED.
- PRESS INC TO INCREMENT THE DIGIT CURRENTLY SELECTED.
- PRESS SHF TO MOVE THE UNDERScore TO THE NEXT DIGIT.
- PRESS NXT TO ENABLE A CHANGE OF THE TIME.
- PRESS DNE TO SAVE DATE CHANGES AND RETURN TO SCREEN 1.

SCREEN 12B: ENTER THE TIME

- THE UNDERScore INDICATES WHICH DIGIT IS CURRENTLY SELECTED.
- PRESS INC TO INCREMENT THE DIGIT CURRENTLY SELECTED.
- PRESS SHF TO MOVE THE UNDERScore TO THE NEXT DIGIT.
- PRESS NXT TO ENABLE A CHANGE OF THE DATE.
- PRESS DNE TO SAVE TIME CHANGES AND RETURN TO SCREEN 1.

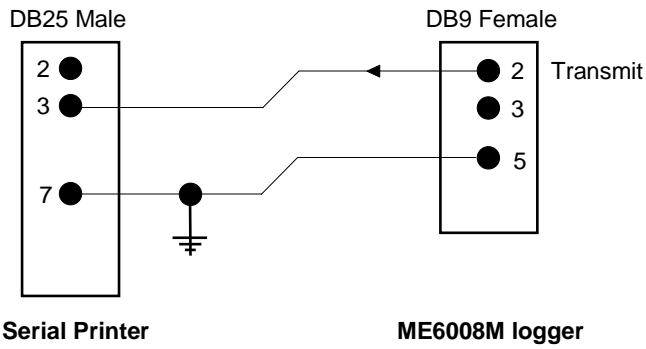

RS232 Communication Cable
ME6008M to Printer
(via back serial port)

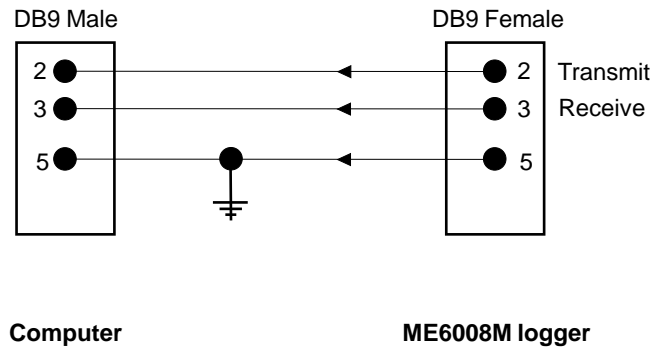

RS232 Communication Cable
ME6008M to Computer
(usually via ME6008M's front serial port but can use the
back serial port after disconnecting printer)

The serial port of the attached printer
(or PC terminal)
must be set to the following:

Baud rate	9600
data bits	8
stop bit	1
parity	none

as from
Aug 2015

Printer Serial Port Settings

Flowmeter	Pulses/Litre	ME6008M Pulses Per Unit setting	
		to print Litres	to print mls
RPFS-P (25mm)	75	0075.00	0000.08
RPFS-P (32mm)	46	0046.00	0000.05
RPFS-P (40mm)	30	0030.00	0000.03
RPFS-P (50mm)	20	0020.00	0000.02
MES20	1000	1000	0001.00
MES25	555	0555.00	0000.56
any	1	0001.00	do not use
any	0.1	0000.10	do not use

Pulses Per Unit settings

Notes:

- To avoid possible noise causing bad records, there is a default threshold of 40 pulses before a batch is logged.

TECHNICAL SPECIFICATIONS - ME6008M Printer Driver Unit

Power supply options	240 vac, 110 vac, 12-24 VDC
Voltage output	+12VDC (to flowmeters, if no Batch Controllers)
Input Channels	8 (Channels 1 & 2 will accept ManuFlo RPFs-P paddlewheel sensors or NAMUR sensors).
Inputs from Flowmeters	Sinking pulse (connect between Pulse and 0v). NPN input.
Inputs - max. frequency	1.5 kHz, each channel
Memory	500 batches (circular buffer)
Communications port	RS232 Serial DB9, 9600 baud* Optional RS232 to USB adapter.
Display	LCD 2-line 16-character LCD display, with backlight
Keypad	Membrane over back switch
Connector Inputs	10-pin 5.08mm plug and socket
Power connector	IEC male chassis connector
Operating current	150 mA
Power consumption	36 W
Max. operating temperature	50 °C
Mounting	Panel mount
Instrument housing	ABS hi-impact case mould. IP65 front face
Dimensions (mm)	206 L, 130 H, 90 D
Cutout (mm)	190 L, 122 H
Weight	1 kg

TECHNICAL SPECIFICATIONS - PRINTERS

	LX300+II Printer	DP8340 Printer
Type	Narrow carriage dot matrix impact printer, 9 pins, 80 columns	Dot matrix printer, 9-pins, 40 columns, 115mm paper width
Paper feed	Continuous	Continuous, friction
Interfaces	1x Serial (set to 9600 baud*), 1x Parallel	1x Serial (set to 9600 baud*)
memory	8kb buffer	1.5 kb buffer
Speed	337cps high speed draft @12cpi, 270cps draft @12cpi, 67cps NLQ @12cpi	2 lines per second bi-directional
Size	366 (w) x 275 (d) x 159 (h) mm	202 (w) x 200 (d) x 98 (h) mm
Weight	4.4 kg	1.9 kg
Power supply	240vac powered.	Standard: 12 VDC (2 Amps) Optional: 100 vac or 240 vac powered.

* as from Aug 2015

Order Code	Description
ME6008M	8-channel Batch Monitor Printer Driver Unit, 240 vac powered
ME6008M-110	8-channel Batch Monitor Printer Driver Unit, 110 vac powered
ME6008M-DC	8-channel Batch Monitor Printer Driver Unit, 12-24 VDC powered
-FP	RS232 port on front of ME6008M (includes RS232 to USB converter cable), in addition to the RS232 port at the back of ME6008M, for easy access to download data to laptop.
LX300+II	Wide printer. Dot matrix, tractor feed. 1 line report. 204mm wide printout, 80 characters.
DP8340	Compact printer. Dot matrix, paper roll. 2 line report. 84mm wide printout. 12 VDC powered.
DP-AC	Transformer pack for DP8340 printer: 100 – 240vac input, 12 VDC output.

Due to continuous product improvement, specifications are subject to change without notice.

Water Batching Equipment

Typical batching installation

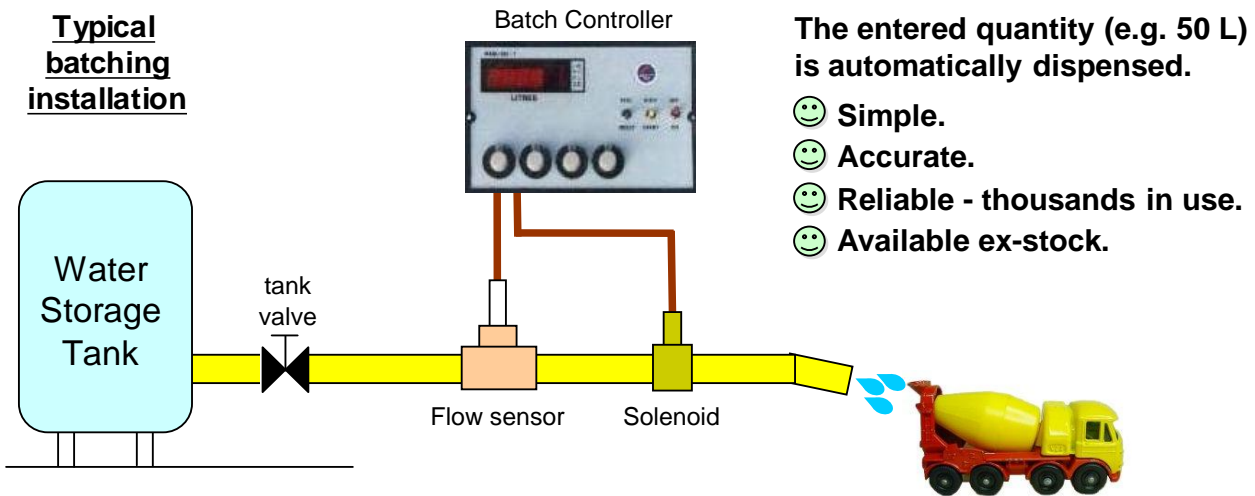

ME995-7 Batch Controller



- **simple to use and calibrate.**
- set batch quantity via rotary dials.
- select up to 9999 Litres.
- easy to connect/disconnect.

ME3000 Batch Controller

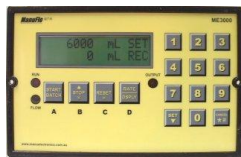

- **ideal for outdoor use (IP64 front face).**
- set batch quantity via touchpad.
- fully programmable. Many safety features.
- displays in either Litres or millilitres.
- easy to connect/disconnect.
- interchangeable with ME995-7 (same size and connection).

RPFS-P Paddlewheel Flow Sensor



- **economical.**
- simple insertion flowmeter, with a range of pipe adapters in various sizes and materials.
- easy to clean.
- for fresh or mild recycled water.

PMS Electromagnetic flowmeter



- **for heavy recycled water.**
- obstructionless bore, virtually maintenance free.
- robust construction.
- high level of performance.
- available in various sizes.

ManuFlo®™

Flow Measurement & Control Products

a division of

MANU ELECTRONICS PTY LTD

41 Carter Road, Brookvale
Sydney NSW 2100 Australia
Ph: + 61 2 9905-4324, 9938-1425
Fax: + 61 2 9938-5852

Web: www.manuelectronics.com.au
Email: sales@manuelectronics.com.au