

SPA



HLPRG

SPA *Site-Programmable Volt &
Milliamp Limit Alarm Trips*



SPA HLPRG Quickstart Guide

Use the front push-buttons to quickly and easily setup the SPA for your application. After programming your alarm using the diagram below, install the unit into your application using the connection diagram and terminal designation table on pages 35 and 36 of this manual.

Use  or  push buttons to scroll through menus and sub-menus. Use SELECT push button to access menu and/or make a choice.

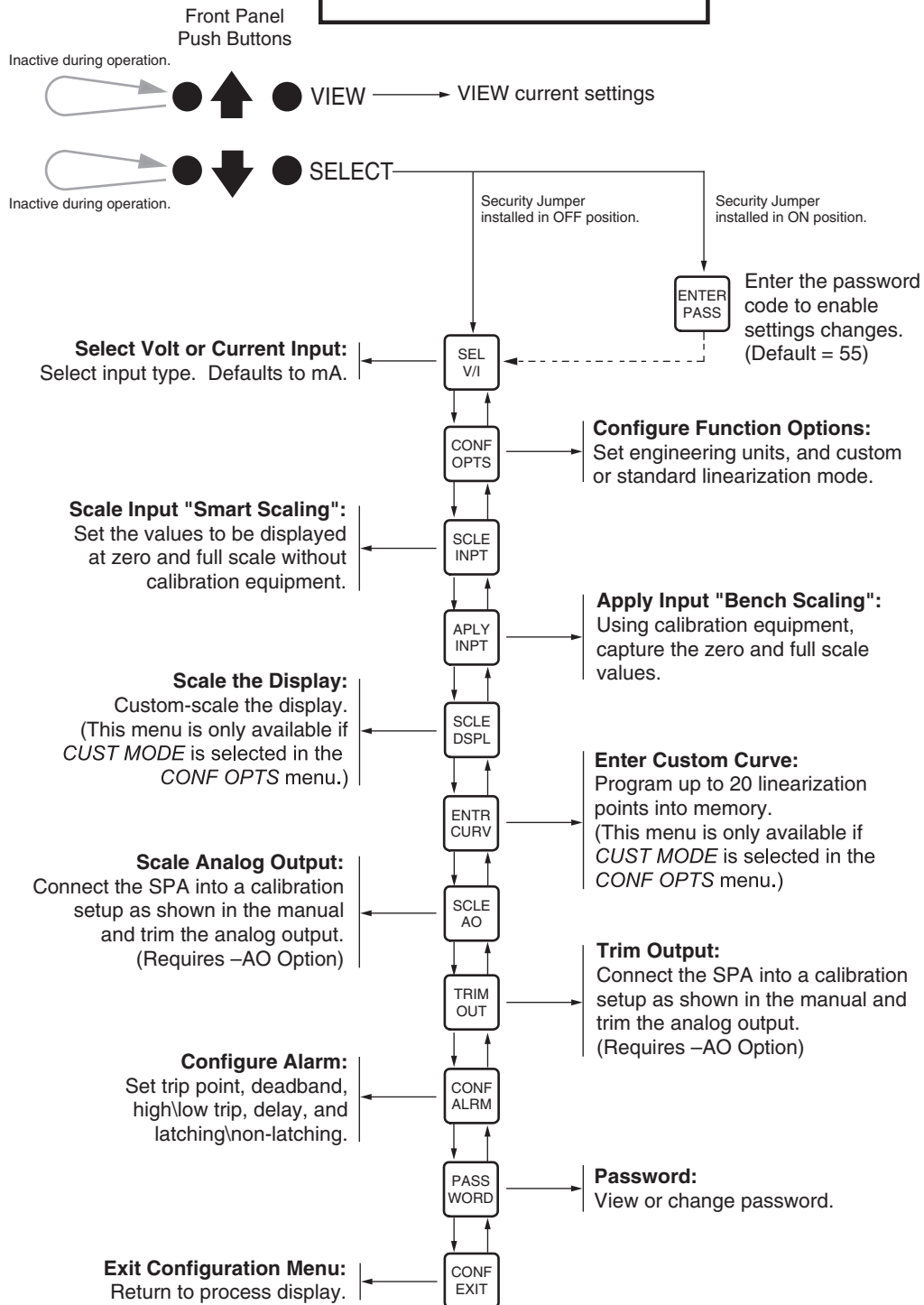

Table of Contents

SPA Volt/Milliamp Alarm Trips	4
Programmable Inputs	4
Programmable Outputs	4
Programmable Display	4
Programmable Input Failure Alarms	4
Universal Mounting	4
Specifications	5
Alarm Terminology	6
Internal Settings.....	7
Programming the HLPRG SPA.....	9
Main Menu/View Settings	9
Password	11
Select Input Type	12
Configure Function Options	13
Scaling Input – "Smart Scaling" the HLPRG	15
Applying Input – "Bench Ranging" the HLPRG	17
Scaling the Display – Setting the Engineering Units in Custom Mode	19
Programming SPA Linearization – Entering Segment Endpoints in Custom Mode	21
Scaling the Analog Output – SPAs with AO	25
Trim Output	25
Configure Alarm(s)	28
Change the Security Password Code	32
Installation	33
Mounting	33
Connections	34
Operation	36
LEDs	36
Manual Reset	36
Error Codes	37
Customer Service	37

SPA

Site-Programmable Volt & Milliamp Limit Alarm Trips

SPA Volt/Milliamp Alarm Trips

This is the users' manual for the Volt/Milliamp Input model of the Moore Industries' Site-Programmable process Alarms (SPA). The SPA monitors a process variable and provides up to four, fully configurable, contact closure outputs whenever that input falls outside a user-set, high or low trip point. SPAs are typically used to activate a warning light, bell, or buzzer; or to initiate a system shutdown, thus acting as simple, but highly reliable and effective means of safe-guarding a process.

Programmable Inputs

The Programmable Current/Voltage unit, or HLPRG SPA (for "High Level" Programmable input), handles either current or voltage inputs in any user-set span in a 0-50mA or 0-10V range. The HLPRG comes standard with transmitter excitation capability for use with 2-wire loop transmitters.

Programmable Outputs

The SPA HLPRG can be equipped with a fully scaleable analog output (-AO) option with the capacity of being switched by the user to either 0-20mA (source or sink), or 0-5V.

The source/sink setting for the optional analog output is controlled by DIP switches that are located behind an easy-to-remove access panel inside the unit's housing.

Programmable Display

With the Volt/Milliamp Input SPA, the user can choose between the Linear function mode and the Custom function mode.

In the Linear Mode, the SPA HLPRG behaves much like a simple input meter. The display is set by the user to show the input in either mA or volts. Its scaling is tied to any input scaling performed. (If equipped with the -AO option, the SPA's output can be scaled independent of the input.)

The SPA HLPRG's Custom Mode sets the unit up for independent programming of input scaling, display scaling, and, if equipped with the -AO option, output scaling. In Custom Mode, the user selects °C, °F, % of scale, Blank (for raw display), or a pre-specified 4-place custom engineering unit label.

Programmable Input Failure Alarms

The SPA can be ordered with 1, 2, 3, or 4 contact closure alarms. Each alarm can be individually programmed for a different trip point, deadband, delay, high or low alarming, latching or non-latching, and failsafe or non-failsafe operation.

The SPA also provides two ways to set the alarm trip point. If an input source is either unavailable or inconvenient, the unit's front panel push buttons and integral liquid crystal display (LCD) can be used to enter the desired trip point.

When a source is available, the SPA can capture trip points by setting the input to the desired trip and pressing the appropriate button.

Failsafe or Non-failsafe alarm functioning is controlled by DIP switches that are located behind an easy-to-remove access panel inside the unit's housing.

Universal Mounting

The SPA is housed in a "universal" DIN case that can be mounted on both 32mm G-type (EN50035) and 35mm Top-Hat (EN50022) DIN-rail. The Installation section of this manual gives the dimensions of the housings for the various SPA configurations.

Specifications

<p>Performance Repeatability: Trip point repeats within $\pm 0.05\%$ of input span Display Accuracy: ± 1 digit; When scaling the display (in Custom Mode), high input-to-display span ratios decrease display accuracy Input Accuracy: Current input, $\pm 5\mu\text{A}$; Voltage inputs, $\pm 1\text{mV}$ Stability: $\pm 0.1\%$ of calibrated span, maximum, over 6 months Deadband: 11.5V or 57.5mA, maximum in Linear Mode; equivalent of maximum input range in user-set engineering units in Custom Mode Response Time: 600 milliseconds (Defined as time from step change on input to alarm state change when alarm is set to trip at mid-point) Alarm Trip Delay: Programmable from 0-60 seconds Line Voltage Effect: $\pm 0.005\%$ of span for a 1% change in line voltage (ac or dc) Isolation: 1000Vrms between case, input, output (units with -AO option) and power terminals (NOTE: High voltage effect of $\pm 0.0004\%$ of output span/V possible with prolonged exposure to ac voltage above 200Vac) Power Consumption: 2-4W, nominal; 6W, maximum</p>	<p>Performance (continued) Input Impedance: $1\text{M}\Omega$ for voltage inputs; 20Ω nominal for current inputs Input Over-Range Protection: 18Vdc for voltage inputs; 180% of maximum input span</p> <p>Performance with Analog Output (-AO Option) WITH ANALOG OUTPUT Output Accuracy: $\pm 0.03\%$ of output span (includes the combined effects of linearity, hysteresis, repeatability, and adjustment resolution) Response Time: 250 msec maximum time for output to go from 10% to 90% for step change on input Ripple (up to 120Hz): Current output, 10mV peak-to-peak max. when measured across a 250Ω resistor; Voltage output, 15mV peak-to-peak max. Output Limiting: 117% of span max., 115% of span typical Load Effect: $\pm 0.01\%$ of span from 0 to maximum load resistance on current output</p> <p>Ambient Conditions Operating Range: -25°C to $+65^{\circ}\text{C}$ (-13°F to $+149^{\circ}\text{F}$) Storage Range: -40°C to $+80^{\circ}\text{C}$ (-40°F to $+176^{\circ}\text{F}$) Ambient Temperature Effect: $\pm 0.005\%$ of output span per $^{\circ}\text{C}$ maximum; $\pm 15\text{ppm}$ of input signal</p>	<p>Ambient Conditions (continued) Relative Humidity: 0-95% non-condensing RFI/EMI Protection: 30V/m - ABC $\leq 0.5\%$ error in reading when tested according to SAMA standard PMC 33.1 Common Mode Rejection: 100dB @ 60Hz Normal Mode Rejection: 40dB @ 60Hz (measured w/current input)</p> <p>Adjustments Front panel push buttons control settings for zero, span, alarm trip points, high/low alarms, etc.; Easy access internal settings select current (source or sink) or voltage output, and failsafe or non-failsafe alarm functions; Internal jumper and menu password protect parameter settings</p> <p>Indicators LCD: 2x4 character, backlit, alphanumeric readout accurate to the nearest digit. Range: -9999 to 9999; Decimal point can be user-set when in Custom Mode LED's: Dual-color TRIP light (one for each relay) shows green for non-alarm, red for alarm; READY light indicates normal operation, extinguishes in the event of any internal failure; INPUT light is always green</p> <p>Weight 456 to 513 g (16.1 to 18.1 oz)</p>
--	--	--

Specifications and information subject to change without notice.

SPA

Site-Programmable Volt & Milliamp Limit Alarm Trips

Alarm Terminology

Before setting up the SPA, or incorporating the unit in your application, Moore Industries suggests that all users take a few moments to become familiar with some of the terms associated with the use of process instrumentation alarms. Figure 1 illustrates the way the SPA alarms operate.

The **Trip Point** is the process input level at which the user wants an alarm relay to change state, typically going into an alarm condition, or “tripping”. In the SPA, the user sets the trip point for each installed relay.

High/Low Alarms: High Alarms trip when the process input goes above the trip point. Low Alarms trip when the process input drops below the trip point. Each of the SPA outputs can be set by the user to function independently as either high or low alarms.

Latching and Non-latching Alarms; once tripped, a latching alarm remains in alarm until the input returns to a non-alarm level **AND** is manually reset. Non-latching alarms return to a non-alarm state whenever the process input returns to the Reset Point. The SPA relays can be set by the user to function as either latching or non-latching.

Figure 1. How Alarms Work with the Process Input

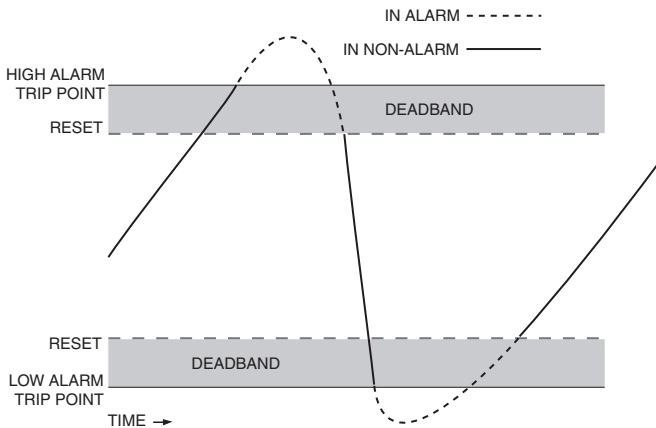

The **Reset Point** is the process input level at which the user wants an alarm relay to change state, typically going from alarm to non-alarm. The reset point is not necessarily the same as the trip point, because most applications call for a buffer zone or “Deadband” around the trip point to allow for minute fluctuations in the process input. In the SPA, the reset point is determined by the deadband setting. Latching SPA alarms will not “clear” unless the reset point has been reached or passed **AND** the manual reset contacts have been shorted.

The **Deadband** is the range in which an alarm remains tripped even after the process input has returned to or passed the trip point. Deadband is not required. When it is not incorporated into an alarm application, the trip point and reset point are the same. The deadband of the SPA is set by the user.

Failsafe Alarms are de-energized when tripped, energized when the process input is at a non-alarm level. Non-failsafe Alarms are energized whenever tripped, de-energized when the process input is at an alarm level. The relays in the SPA can be switched from failsafe to non-failsafe at any time by the user.

Normal is the term used to describe the “shelf-state” of relay contacts. The contacts of a *Normally Open* relay are open (infinite resistance) when the relay is not energized. The contacts of a *Normally Closed* relay are open when the relay is energized (closed when not energized).

NOTE:

Sometimes a non-alarm input level is referred to as being in a “normal” condition. This practice is intentionally avoided in this manual. Do not confuse the term “normal”, as in Normally Open or Normally Closed, with a non-alarm input condition. In this manual, “normal” is an exclusive reference to the shelf state or quiescent state of an alarm’s relay contacts, whether open or closed.

Internal Settings

The Failsafe/Non-failsafe relay and the password security functions of the SPA are controlled by means of simple DIP switches and a single jumper inside the unit housing.

If the unit is equipped with the AO option, voltage and current sink/source selection is also inside.

The SPA housing is fitted with a sliding access door in its bottom panel. Figures 3, 4, and 5 show the panel and the location of each of the controls for setting:

- Password Security ON/OFF (**Figure 2**)
- Failsafe/Non-failsafe Alarm Function (**Figure 3**)
- Current Source/Sink or Voltage (**Figure 4**)
(Available in AO-equipped SPAs only)

NOTE:

SPAs equipped with the DPDT option make use of switches 1 and 2 only (see Figure 3).

Figure 2. Setting the Internal Jumper for Password Security ON or OFF

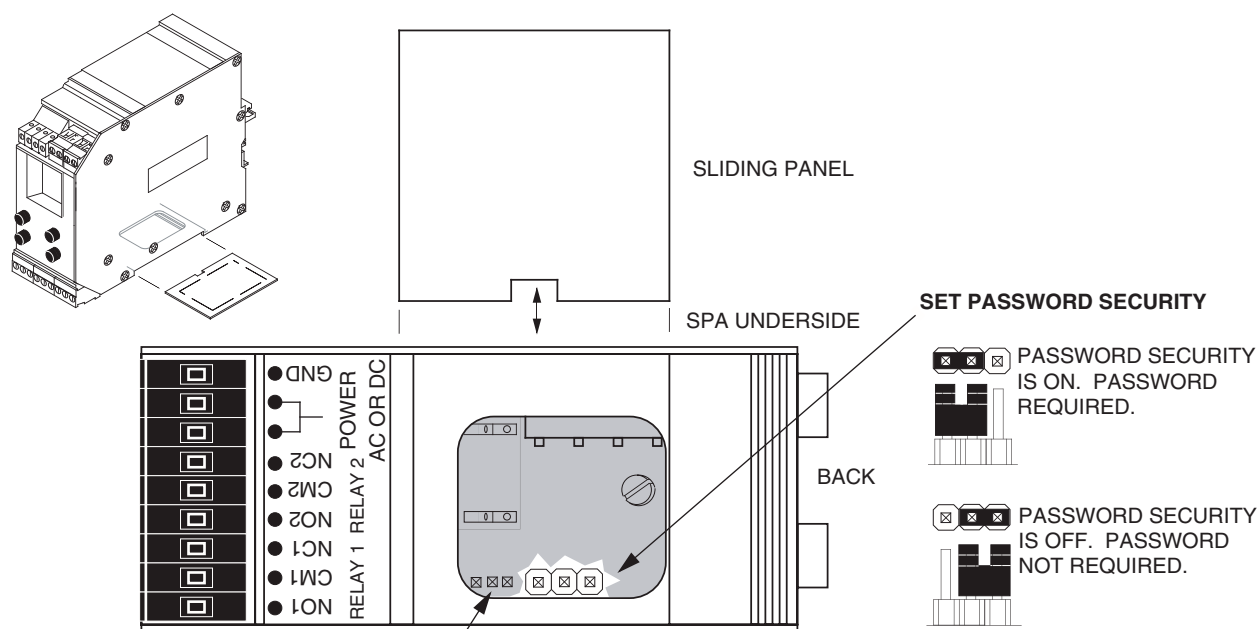

NOTE: THE THREE PINS TOWARD THE LEFT SIDE OF THE COMPARTMENT ARE FOR FACTORY TESTING ONLY. DO NOT INSTALL JUMPERS ON THESE PINS!

SPA

Site-Programmable Volt & Milliamp Limit Alarm Trips

Figure 3. Setting the Internal DIP Switches for Failsafe or Non-Failsafe Alarm Function

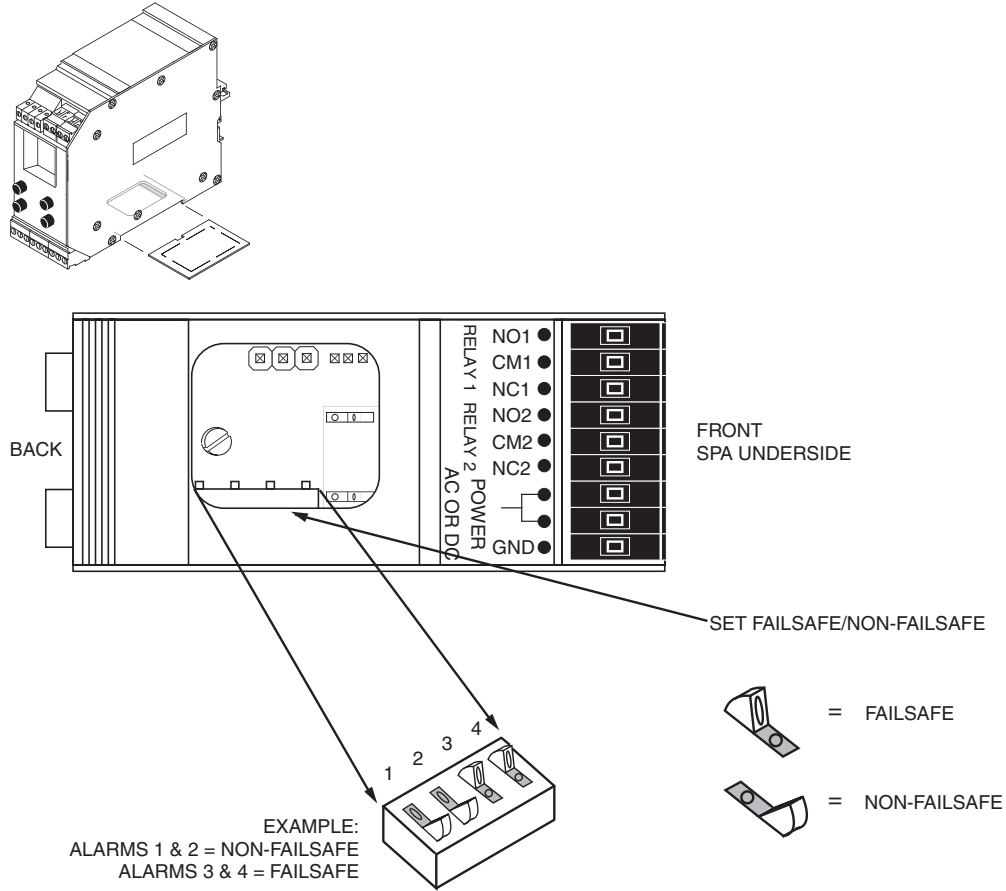
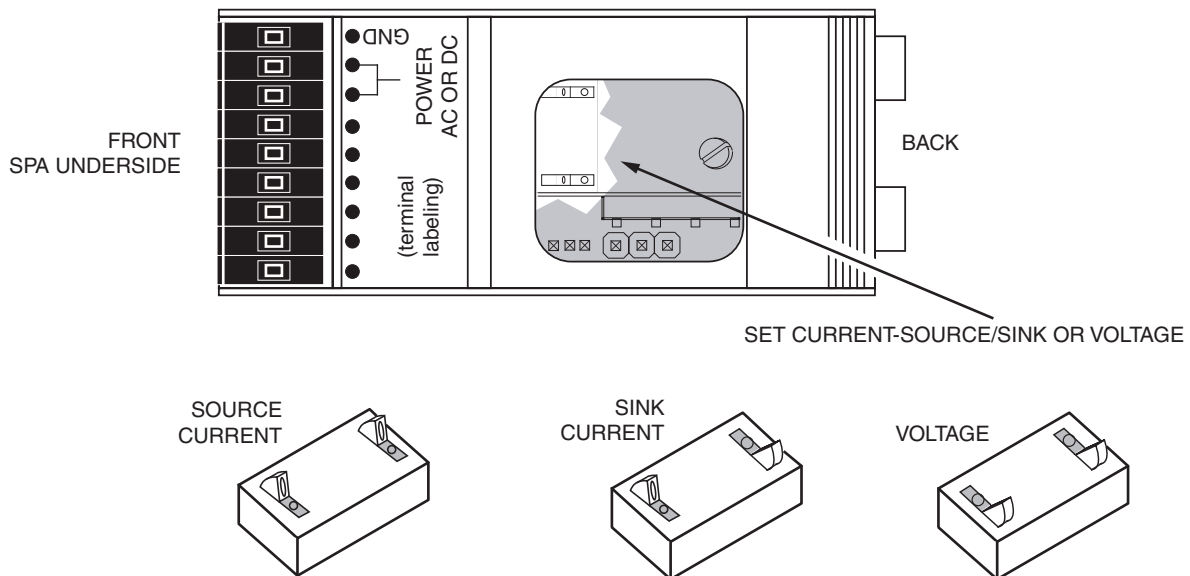

Figure 4. Setting the Internal DIP Switches for Current Source/Sink or Voltage (AO-equipped SPAs only)



Programming the HLPRG SPA

The High Level Input SPA operating parameters are set, and the settings are stored in on-board, non-volatile EEPROM. There are four push buttons on the unit front panel; VIEW, SELECT, an UP arrow, and a DOWN arrow. Together with the prompting messages displayed on the LCD, these are used to access menus, and to view and change the settings for:

- **Select Input Type: current (I) or voltage (V)**
- **Select Functional Setting (Linear Mode or Custom Mode) and, if selected, set Custom Mode Engineering units.**
- **Scale Input — Smart Scaling**
- **Apply Input — Bench Scaling**
- **Scale Display readout**
- **Set Linearization Curve (Custom Mode only)**
- **Scale Analog Output (AO-equipped units only)**
- **Trim Analog Output (AO-equipped units only)**
- **Configure Alarm Functions (Trip points, etc.)**
- **Change/View Password**

Main Menu/View Settings

Figure 5 gives an overview of the first level of menus used to configure the SPA.

On power-up, the SPA defaults to a display of the measured value. Pressing the VIEW button accesses a series of displays that show, in succession, the settings currently stored in unit memory (see Figure 6).

Depending upon whether or not the Security Jumper has been installed (see Figure 2), SELECT will access either the first screen in the main configuration menu, “SEL V/I”, or the password code query screen, “ENTR PASS”.

Once the Main Menu has been accessed, the up and down arrow buttons are used to move through all of the sub-menus in a loop. Pressing the SELECT button accesses the first screen of the sub-menu shown on the LCD.

SPA

Site-Programmable Volt & Milliamp Limit Alarm Trips

Figure 5. The HLPRG SPA Main Menu

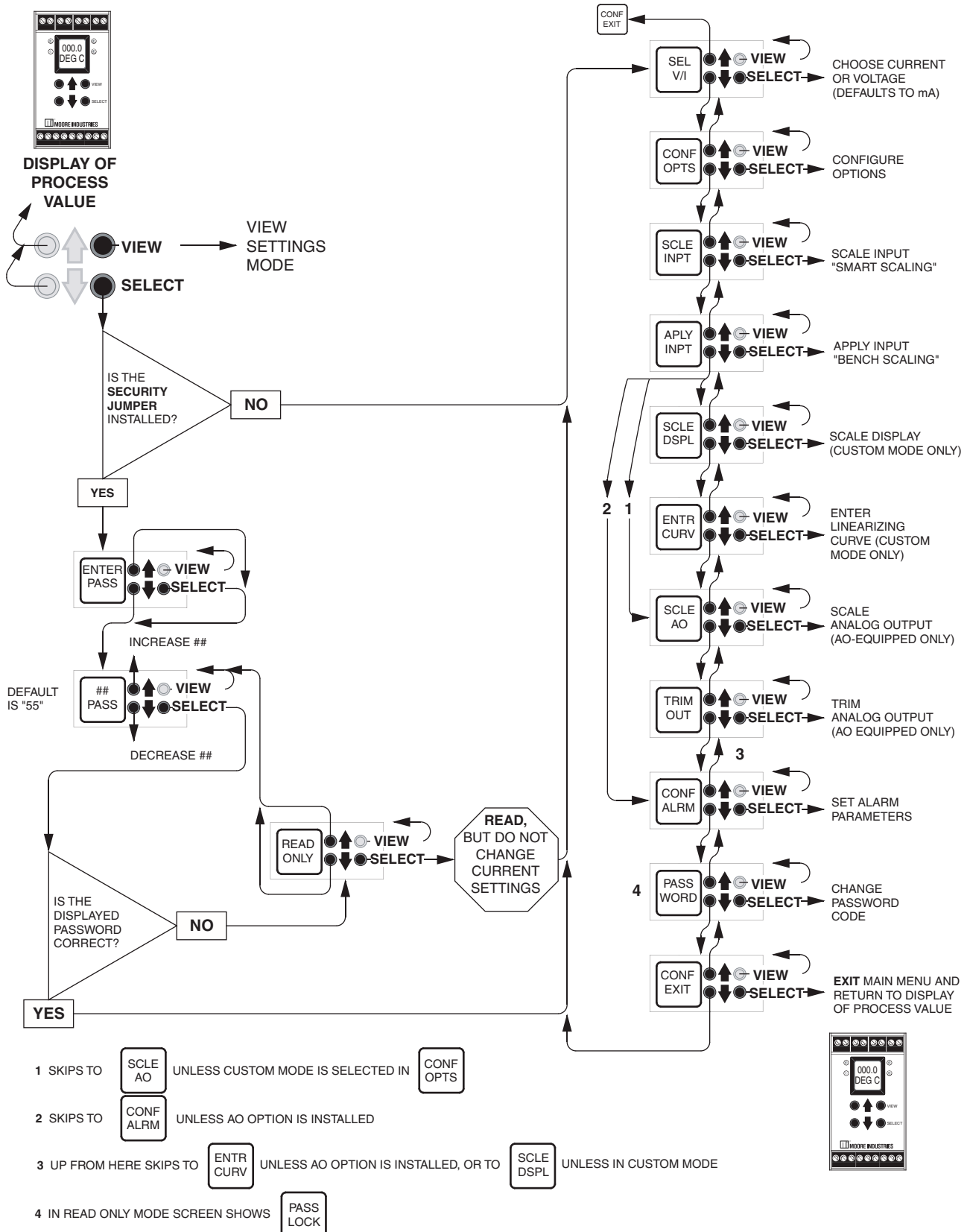

Password

This menu is bypassed if the Password Security Jumper is not installed (see Figure 2). If the jumper is installed, the menu comes up when SELECT is pressed from the display of the process variable input. The flow chart is shown as part of Figure 5.

1. If the jumper is installed, pressing SELECT from the display of the process variable input will bring up the "ENTR PASS" screen.
2. Use the up or down arrow buttons, or press SELECT again to access "55 PASS", the default screen for this point in the menu.
3. Use the up or down arrow buttons to display the correct password.

When the correct password number is displayed, press SELECT.

NOTE:

If the correct password is not known, the unit settings can be viewed, but not changed, as shown in Figure 17.

4. If you have entered the correct password, the Select Input Type menu, "SEL V/I", will be accessed. If not, the display will show a "READ ONLY" message.
5. From "READ ONLY", press SELECT to view the settings in the various menus. READ ONLY mode locks out any attempt to make changes to the settings.

Press the up or down arrow buttons to return to "55 PASS" from "READ ONLY".

NOTE:

The menu to set or change the Password stored in SPA memory is presented later in this section of the manual.

Figure 6. The HLPRG SPA View Mode

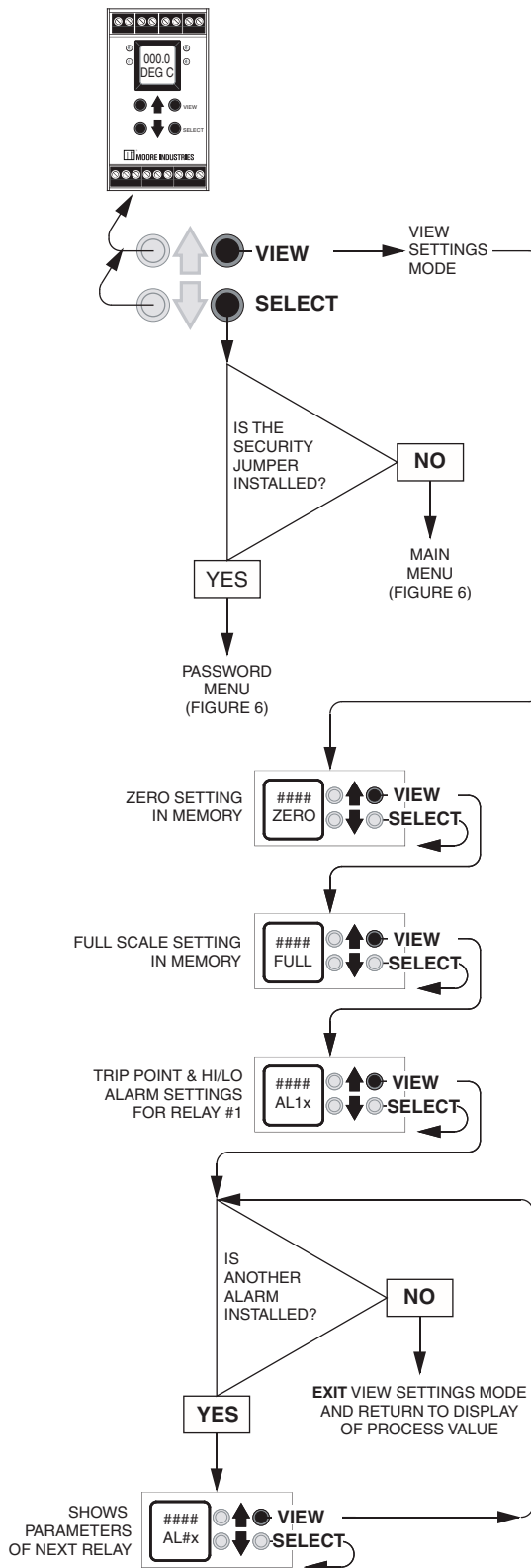

Configure Function Options

This menu allows the user to choose between Linear and Custom modes of functioning.

Linear Function. In its Linear Mode, the HLPRG SPA behaves much like a simple input meter. The display is set by the user to show the input in either mA or volts. Its scaling is tied to any input scaling performed (set in another menu). If equipped with one of the AO options, SPA output also can be scaled independently with respect to the input.

Custom Function. The HLPRG's Custom Mode sets the unit up for *independent* programming of input scaling, display scaling, and, if equipped with the AO option, output scaling. In Custom Mode, the user can select °C, °F, % of scale, or Blank (for raw display); or a user-specified, 4-place engineering unit, set at the factory.

Also, if Custom Mode is selected, the user can select either linear or non-linear display scaling, which enables a user-programmed, 20-point linearization set in a separate menu.

NOTE:

The SPA's Linear Mode and its linearizing of the Custom Mode functioning are not the same. Refer to Figure 8.

Figure 8 gives an overview of the HLPRG SPA Configure Options menu.

1. From the "CONF OPTS" screen of the Main Menu, press SELECT. This brings up "SET FUNC", which is the access screen for choosing between Linear and Custom Function Modes.

2. Press SELECT again to set the desired function mode, or use the arrow buttons to move to "EXIT OPT" and bypass the Select Options procedure.

Note that, depending upon the Mode setting, it may be necessary to bypass "SET LIN" screen.

3. With "SET FUNC" showing on the LCD, use the arrow buttons to toggle between "CUST FUNC" and "LINR FUNC". Refer to the explanation above for information about each of the operating modes.
4. When the LCD shows the desired mode, press SELECT.
5. If "CUST FUNC" was selected, go to step 7.
6. If "LINR FUNC" was selected, the LCD will now show "EXIT OPTS".

Use the arrow buttons to return to "SET FUNC" (step 3), or press SELECT to return to the Main Menu.

7. Press SELECT to begin the process of setting the desired engineering units to be displayed during HLPRG operation.
8. Use the arrow buttons to "scroll" through the available options.
9. When the appropriate units are showing on the LCD, press SELECT.

This brings up a sub-menu that allows the user to choose between a linearized or non-linearized display of the selected, custom engineering units.

10. Use the arrow buttons to toggle linearization on or off, then press SELECT to go to "EXIT OPTS".
11. Press SELECT again (from "EXIT OPTS") to return to the Main Menu, or to correct any mistake, go to step 2.

SPA

Site-Programmable Volt & Milliamp Limit Alarm Trips

Figure 8. The HLPRG SPA Configure Options Menu

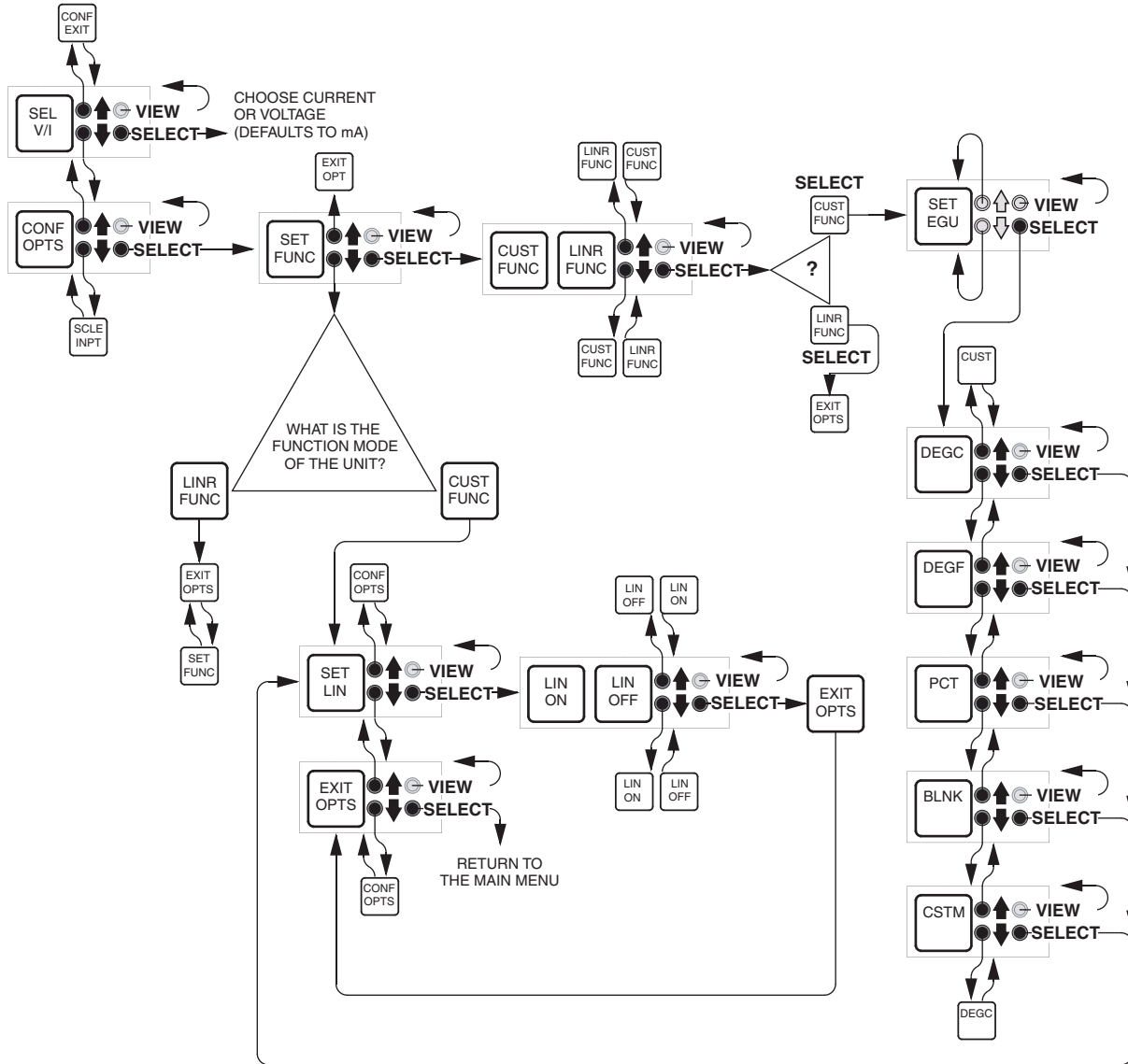

Scaling Input — “Smart Scaling” the HLPRG

This feature of the HLPRG SPA allows users to set the zero and full scale values of the input from the intended application without having to connect the unit to any calibration equipment.

With Smart Scaling, the LCD and menus are used to enter the value for zero and full scale, in either milliamps or volts.

Once these two input parameters are set, the HLPRG automatically routes the user to the next appropriate menu; Scale the Display, for Custom Mode users; Scale the Output, for Linear Mode users (with AO-equipped HLPRG SPAs); or Configure Alarms, for Linear Mode users whose units are not equipped with analog output.

Figure 9 shows the Smart Scaling menu.

1. From the readout of “SCLE INPT” on the Main Menu, press SELECT.
2. Use the arrow buttons to “scroll” from “SET ZERO” to “SET FULL”, or to “EXIT SCLE” to abort Smart Scaling and return to the Main Menu.
3. When the desired parameter shows on the LCD, press SELECT.

The LCD will show the engineering units selected in Configure Options menu, discussed previously in this section.

4. Use the arrow buttons to set the display to show the known zero or full scale input from the intended application. Holding the push button in accelerates the display change.
5. When the LCD shows the correct setting, press SELECT.
6. If “EXIT SCLE” is showing and both zero and full scale have not been set, go to step 2.
7. If both the zero input and full scale input parameters have been entered into the SPA memory, go to step 9.
8. Go to step 4.
9. Use the arrow buttons to “scroll” to “EXIT SCLE” and press SELECT.

If the SPA Custom Mode was selected in the Configure Options menu, the next menu shown will be Scale the Display, since in Custom Mode the input, display, and output (if present) are independent.

If the SPA Linear Mode was selected in the Configure Options menu, the next menu shown will either be Scale Analog Output, for units equipped with an AO option, or Configure Alarms.

SPA

Site-Programmable Volt & Milliamp Limit Alarm Trips

Figure 9. Smart Scaling the HLPRG SPA Input

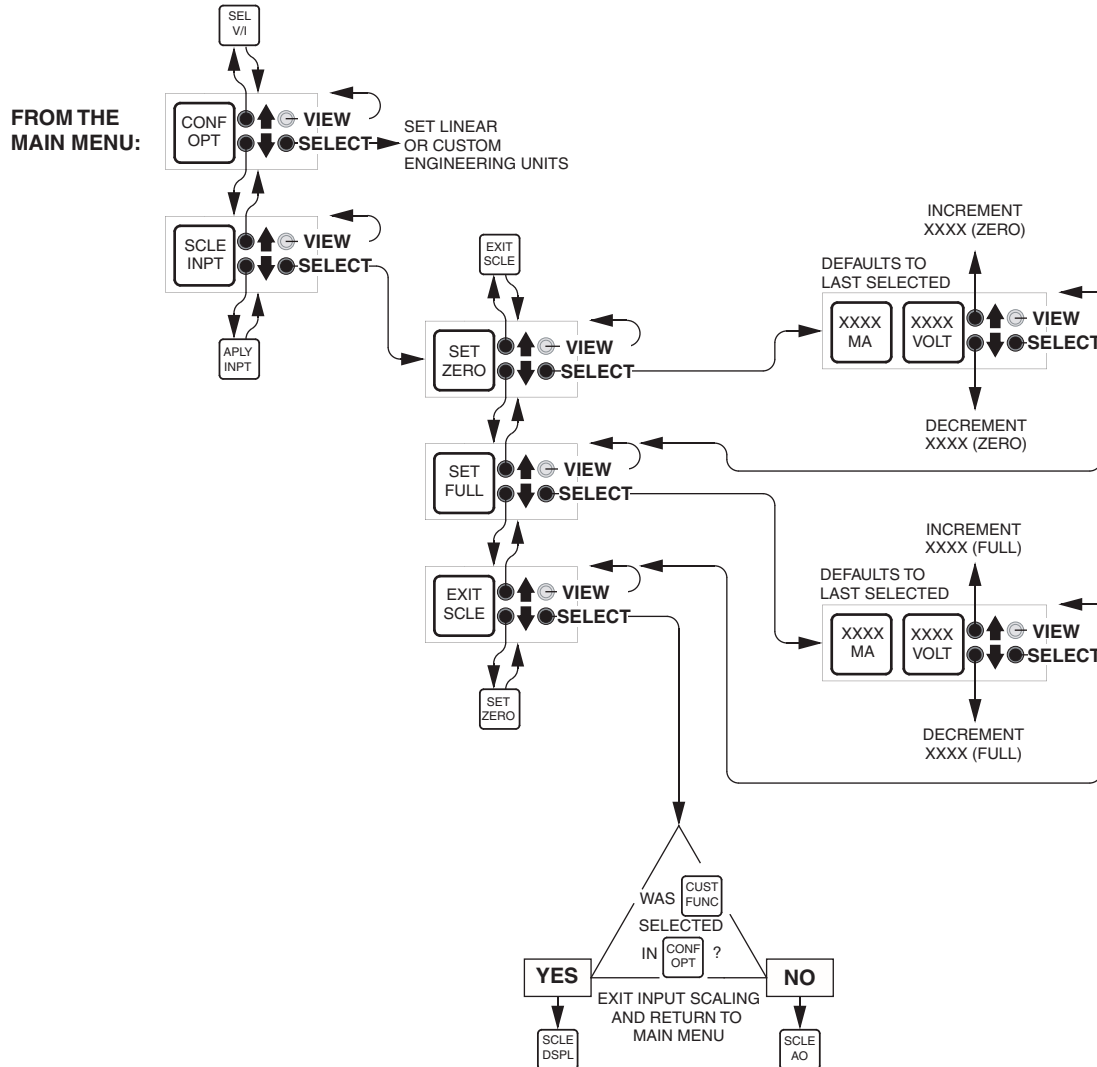

Applying Input — “Bench Ranging” the HLPRG

With this method of calibrating input to the SPA, the inputs are “captured” at their zero and full scale levels.

Figure 10 shows the setup required for applying and capturing input scaling for the HLPRG SPA. After the connections shown in the diagram have been made, apply appropriate power and allow approximately 5 minutes for unit warm-up/stabilization.

Figure 11 shows the SPA menu used in this procedure.

Figure 10. The HLPRG SPA Bench Scaling Setup

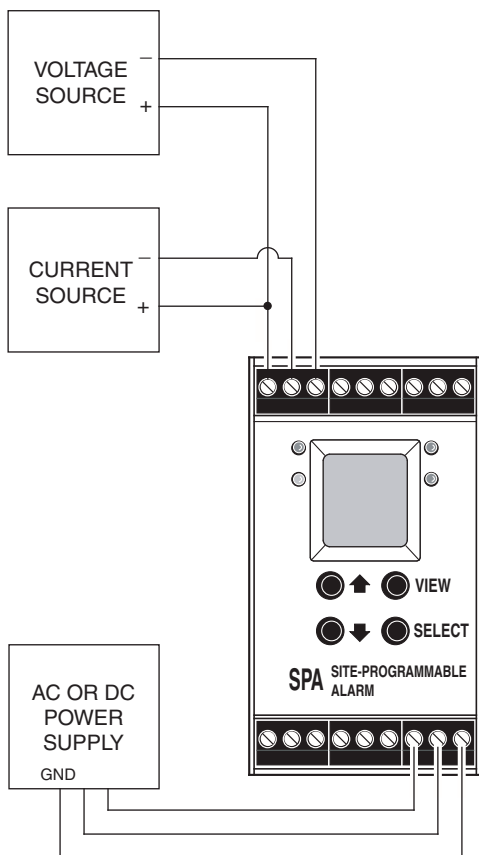

1. From the “APLY INPT” point of the HLPRG SPA Main Menu, press SELECT.
2. Use the arrow buttons to bring up the desired parameter, Save Zero, Save Full, or Exit Input to abort the Bench Ranging procedure.
3. When the appropriate display for the parameter to be input is showing on the LCD, press SELECT.

The display will show the engineering units selected in the Configure Options menu, discussed earlier in this section.

4. Vary the input to either the zero or full scale level from the intended application.
5. When the display shows the appropriate readout, press SELECT to capture the value in the HLPRG SPA memory.
6. Repeat steps 2 through 5 until both the zero and full scale values from the intended application have been captured.
7. If the SPA has been set up to operate in Linear Mode and no analog output option is present, go to step 10.
8. If the SPA has been set up to operate in Linear Mode and an analog output option is present, go to step 11.
9. If neither step 7 or 8 apply, use the arrow buttons to bring up the “EXIT INPT” display from step 5, and press SELECT to return to the Main Menu at the Scale Display point.
10. Use the arrow buttons to bring up the “EXIT INPT” display from step 5, and press SELECT to return to the Main Menu at the Configure Alarm(s) point.
11. Use the arrow buttons to bring up the “EXIT INPT” display from step 5, and press SELECT to return to the Main Menu at the Scale Output point.

SPA

Site-Programmable Volt & Milliamp Limit Alarm Trips

Figure 11. The HLPGRG SPA Bench Scaling Menu

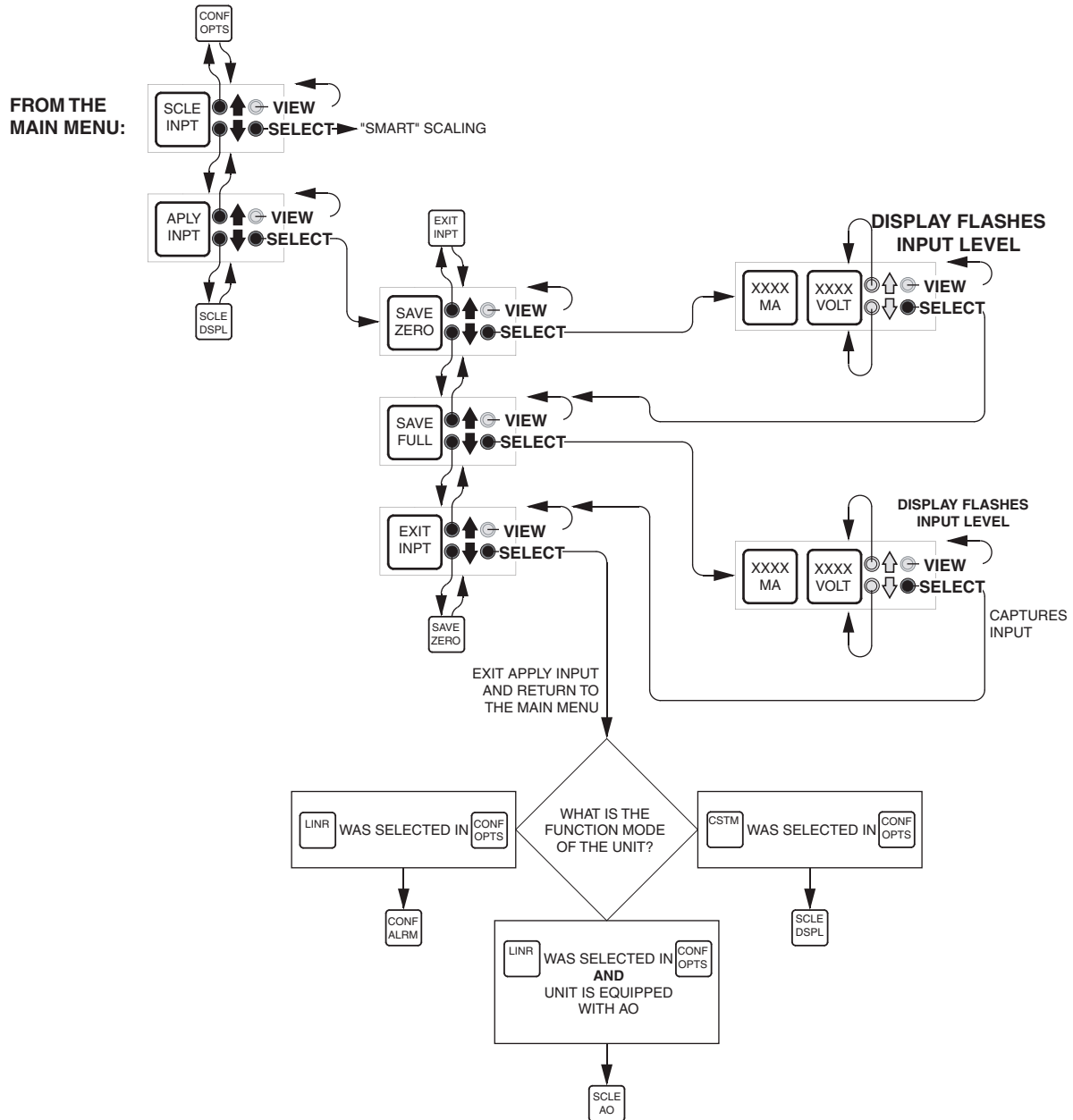

Scaling the Display — Setting the Engineering Units in Custom Mode

This is the menu with which the HLPARG SPA user can further “customize” unit operations. This menu is available only in units where the “CUST FUNC” Custom Mode selection has been made in the Configure Options menu, earlier.

NOTE:

The settings for decimal place and zero and full scale display that are entered into SPA memory are saved as numeric values as opposed to percentages.

They are independent of settings for input scaling and trip points.

If changes are made to the Input Scaling or Trip Points (in the Configure Alarms menu), this menu must be accessed and the values changed appropriately in order to carry any scaling changes through to the display.

Figure 12 shows the menu for this procedure.

1. From the “SCLE DSPL” screen of the Main Menu, press SELECT.
2. Use the arrow buttons to “scroll” through the parameters for scaling the display:
 - Set the decimal position
 - Set the displayed zero
 - Set the displayed full scale
 - Exit the Display Scaling procedure and return to the Main Menu
3. When the parameter that is to be set is showing on the LCD, press SELECT.
4. Refer to Figure 12 for information on the function of the up and down arrow buttons for each of these parameters.
5. When the parameter has been set appropriately for the intended application, make a note of the scaling for future reference, and press SELECT.
6. Repeat steps 2 through 5 until all parameters for the display have been set as required.
7. With “EXIT DSPL” showing on the LCD, press SELECT to return to the Main Menu.

SPA

Site-Programmable Volt & Milliamp Limit Alarm Trips

Figure 12. Scaling the HLPRG SPA Display in Custom Mode

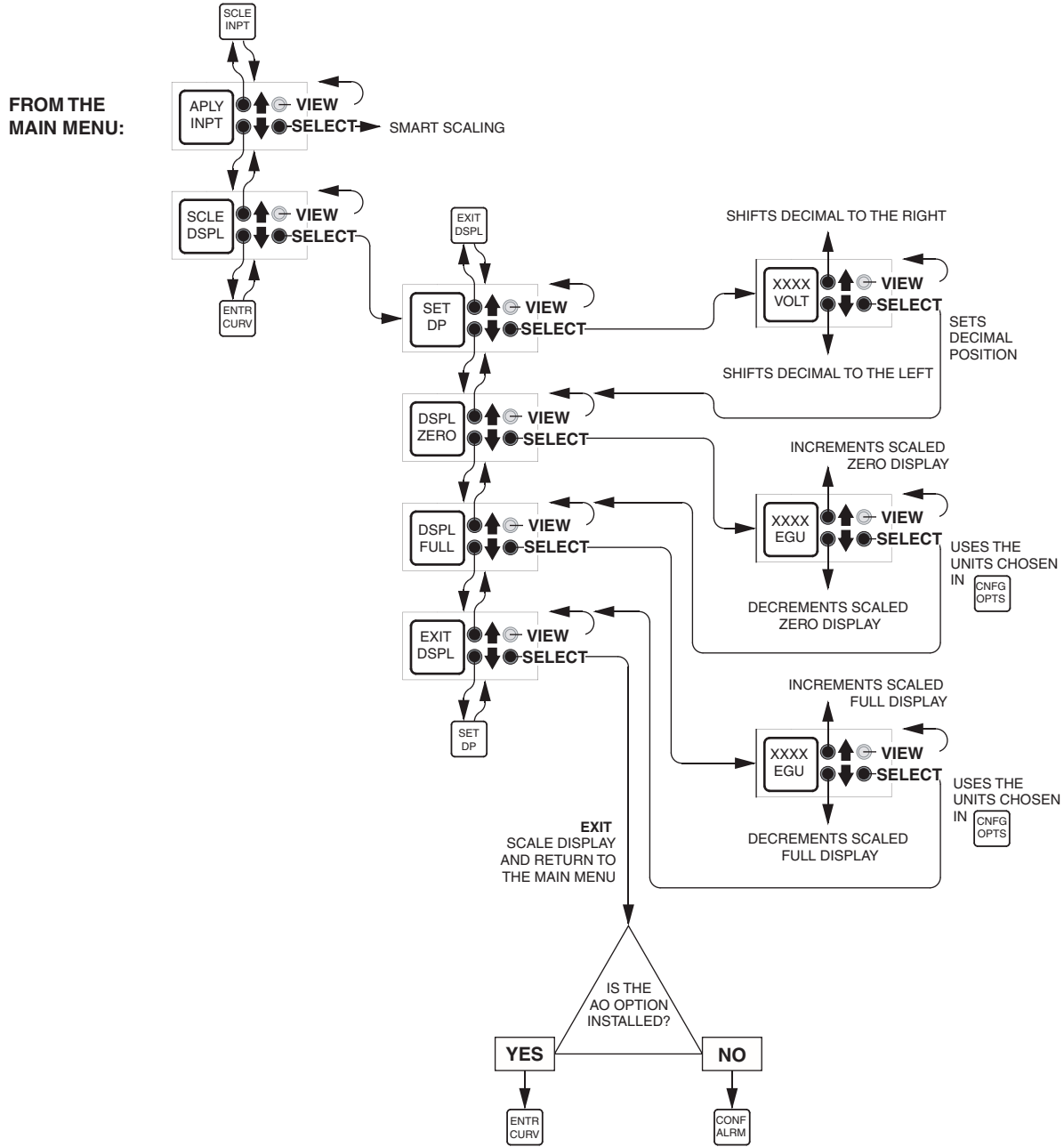

NOTE: MAXIMUM DISPLAY RANGE* = $\frac{\text{INPUT RANGE}}{\text{INPUT ACCURACY}}$
 (1mV FOR VOLTAGE INPUTS
 5mA FOR CURRENT INPUTS)

*DISPLAY FULL SETTING - DISPLAY ZERO SETTING

Programming SPA Linearization — Entering Segment Endpoints in Custom Mode

From this menu the user can program up to 20 linearization points into non-volatile HLPNG SPA memory. This capability works exclusively with the unit's Custom Mode to make the SPA display linear with respect to its scaled input. When enabled (in the "CONF OPTS" menu, discussed earlier), the SPA's Custom Mode sets the unit to display the *linearized* input value in the user-set engineering units.

As mentioned, the "ENTR CURV" menu is active only when the SPA's "CUST FUNC" Custom Mode selection has been made in the Configure Options menu.

IMPORTANT:

Input zero and full scale as well as display zero and full scale must be programmed prior to programming the linearization curve.

The procedure consists of defining the number of points that are to constitute the linearization curve, then specifying first the input, then its corresponding display value at each point. Figure 13 shows the menu.

1. Make sure that the zero and full scale values have been entered into memory for:
 - Input scaling ("smart" scaling) or input capturing (bench scaling)
 - Display scaling
 - Analog Output (if present)
2. From the "ENTR CURV" point of the main, HLPNG SPA menu, press SELECT.
3. Press SELECT from the next screen, "NUMB PNTS", to bring up a screen for entering the number of points to be used in the linearization curve.

or

Press the down arrow button to bring up the "ENTR PNT" screen. Pressing SELECT will bring up a screen allowing you to enter a particular point that is to be changed, assuming that the curve has been entered previously.

The "rules" for entering points are:

- $X_z < X_n < X_{n+1} < X_{n+2} < \dots < X_{n+19} < X_f$
Where X_z =Input zero, in this case, 0mA; and X_f =Input full scale, in this case, 50mA; X_n, X_{n+1} through X_{n+19} = Input curve
- $Y_z < Y_n < Y_{n+1} < Y_{n+2} < \dots < Y_{n+19} < Y_f$
Where Y_z =Display zero, in this case, 0%; and Y_f =Display full scale, in this case, 100%; Y_n, Y_{n+1} through Y_{n+19} = Display curve

NOTE:

*The endpoints of the curve must fall **within** a range defined by the zero and full scale values for both the input **and** the display (see the graph, below).*

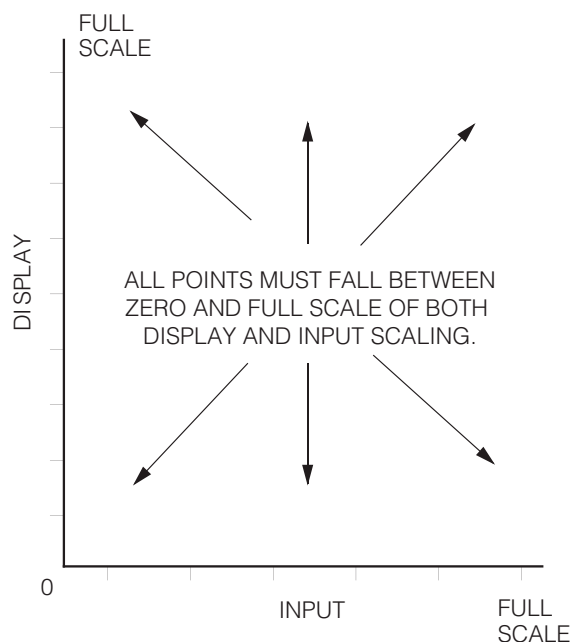

4. When the display shows the point number that is to be programmed, press SELECT.

SPA

Site-Programmable Volt & Milliamp Limit Alarm Trips

Figure 13. Entering the Linearization Points for the SPA in Custom Mode (only)

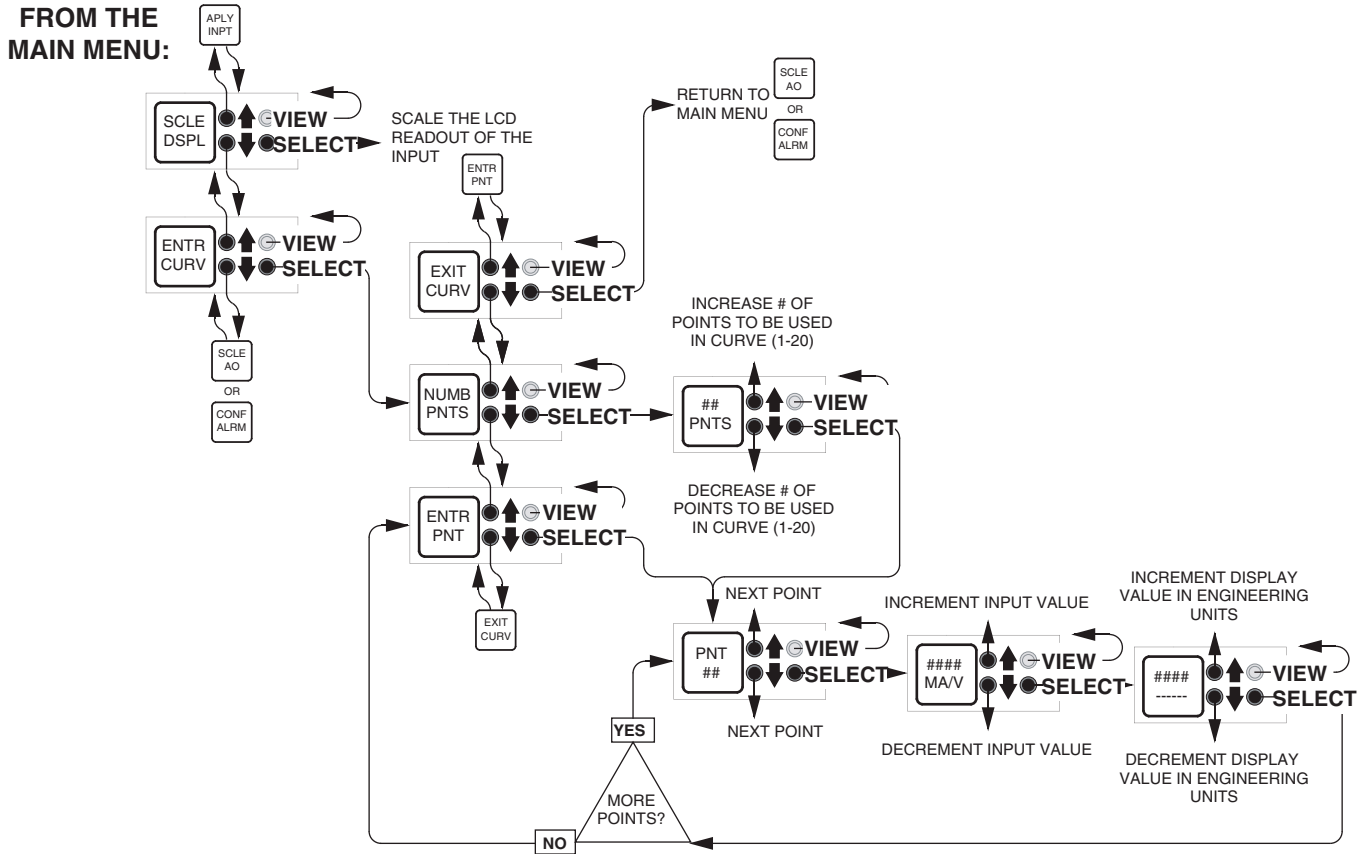

- Use the arrow buttons to set the desired INPUT VALUE for the first point. Note that the default units are those selected in the "SEL V/I" menu, mA or V.
- When the display shows the desired value, press SELECT.
- The next screen prompts for the value that the DISPLAY is to show at the input level just programmed (steps 5 and 6).

- When the display shows the desired value, press SELECT.
- The SPA automatically brings up the screen "PNT ##" for the next point to be programmed (if the "NUMB PNTS" value was changed), or returns to the "ENTR PNT" screen to allow the user to select the next point. From "ENTR PNT" the user can also exit to the main menu.

NOTE:

When programming linearization points, the LCD will flash if an attempt is made to enter an "illegal" point.

- Refer to the following example for further clarification.

**EXAMPLE -
Programming an HLPRG Linearization Curve**

Following the instructions is step 1 on the preceding page, a SPA is set up with the following parameters:

- 0-50mA input
("SEL V/I", and "SCLE INPT" or "APLY INPT")
- 0-100% LCD readout
("PCT" in "CUST FUNC" under "CONF OPTS", and 000.0 for zero, 100.0 for full scale in "SCLE DSPL")

Use a graph to show the relationship between INPUT and DISPLAY:

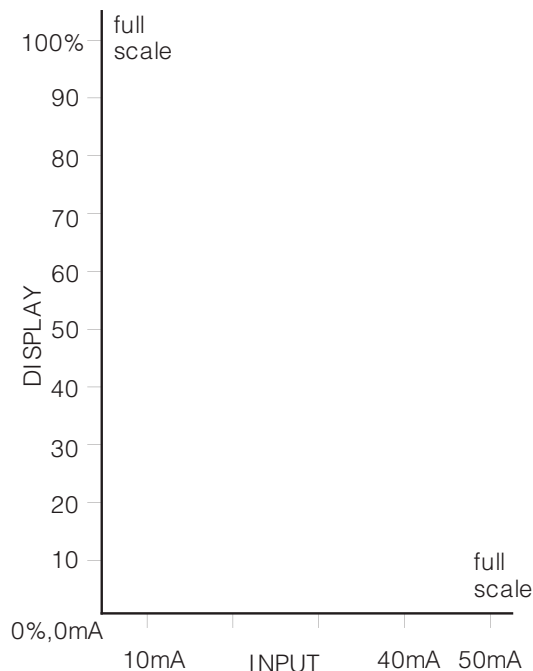

As shown, plot the INPUT points along the X axis, and the DISPLAY points along the Y axis.

The "rules" for inputting linearization points are as follows:

- $X_z < X_n < X_{n+1} < X_{n+2} < \dots < X_{n+19} < X_f$
Where X_z =Input zero, in this case, 0mA;
and X_f =Input full scale, in this case, 50mA;
 X_n, X_{n+1} through X_{n+19} = Input curve
- $Y_z < Y_n < Y_{n+1} < Y_{n+2} < \dots < Y_{n+19} < Y_f$
Where Y_z =Display zero, in this case, 0%:
and Y_f =Display full scale, in this case, 100%;
 Y_n, Y_{n+1} through Y_{n+19} = Display curve

From steps 2 and 3 of the procedure, 5 points between 0 and 50mA are chosen.

"5" is entered in the "NUMB PNTS" screen. When SELECT is pressed, the "PNT 01" screen appears. Pressing select, the arrow buttons are used to enter the first input point, which, in this example is to be 10mA.

When SELECT is pressed, we are prompted for the DISPLAY at point 01, which, in this example, we want to be 20%. Our graph would look like this for point 01:

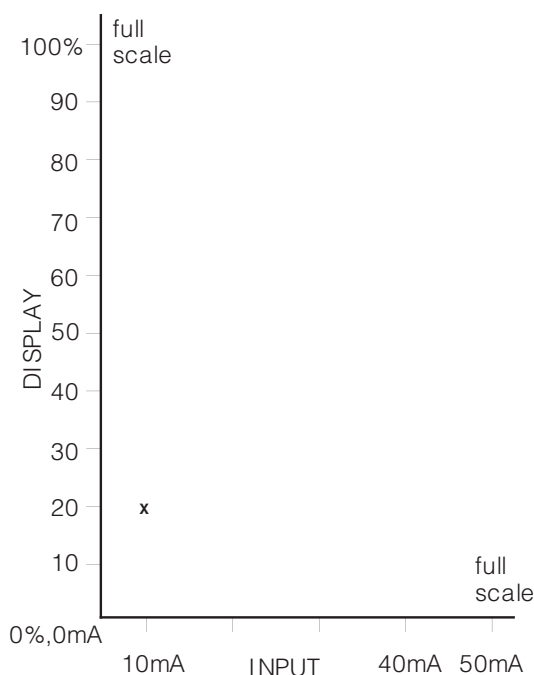

SPA

Site-Programmable Volt & Milliamp Limit Alarm Trips

Following the menu prompts for each of the five points, the graph would look like this:

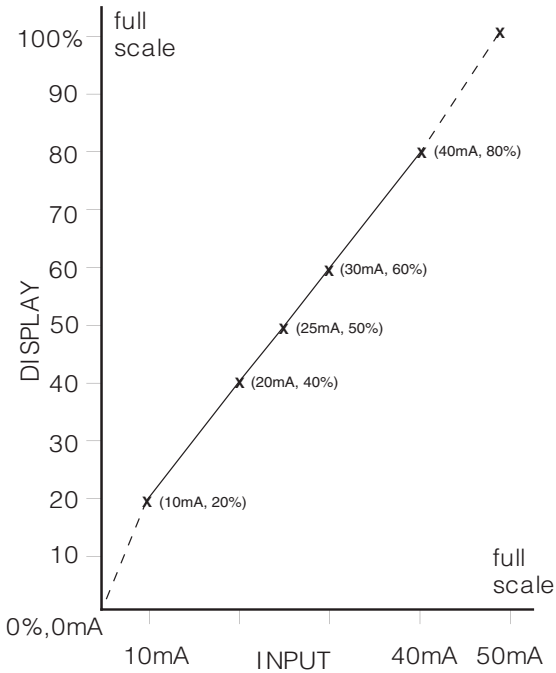

Notice that the 5 points create 4 segments. The end segments, shown by the dashed lines are defined by the coordinates of the input scale and the display scale and the adjacent curve points.

Any inputs that fall outside the input scale are defined by the same slope and offset of the dashed segments in the graph.

A 20-point curve can therefore define 21 segments.

If more points are to be added...

the SPA menu automatically takes the user to the point that has not yet been defined. The user cannot exit the curve programming until all points are defined.

NOTES:

If **INPUT SCALING (X-axis)** is changed, during SPA operation, to fall within the curve values (violation of the "rules" on the preceding page), a **TABLE ERROR** message will be returned.

If the **DISPLAY SCALING (Y-axis)** is changed, the curve coordinates automatically change to proportionally fall within the new display scale.

If the display scaling in our example were changed, the following would be implemented automatically by the unit:

INPUT	INITIAL DISPLAY SCALE	0-750 UNITS	500-1000 UNITS
10mA	20%	150	600
20mA	40%	300	700
30mA	60%	450	800
40mA	80%	600	900

NOTE:

When a **TABLE ERROR** occurs, change the **INPUT SCALE** to "follow the rules".

The change will not be processed by the SPA until the Configuration menu is exited, or until power is recycled.

Scaling the Analog Output — SPAs with AO

This menu is only applicable to those HLPRG SPAs equipped with an analog output option.

Scaling for the analog output of the HLPRG SPA is stored as numerical values in unit memory. They are not stored as percentages of scale.

NOTE:

If either Input Scaling or Display Scaling is changed, any existing scaling operating on the analog output (if present) must also be changed.

Figure 14 shows the menu for this procedure.

1. From the “SCLE AO” display of the Main Menu, press SELECT.
2. Use the arrow buttons to “scroll” through the parameters for scaling the output:
 - Set the zero value
 - Set the full scale value
 - Exit the Output Scaling procedure and return to the Main Menu
3. When the parameter that is to be set is showing on the LCD, press SELECT.
4. Use the arrow buttons to increment and/or decrement the displayed parameter. Holding the arrow button in accelerates changes.
5. When the parameter has been set appropriately for the intended application, make a note of the scaling for future reference, and press SELECT.
6. Repeat steps 2 through 5 until all parameters for the display have been set as required.
7. With “EXIT Z/FS” showing on the LCD, press SELECT to return to the Main Menu.

Trim Output

This procedure is only required on those SPAs equipped with the AO option.

Figure 15 shows the setup needed. Figure 16 shows the menu.

Connect the unit as shown, apply the appropriate power, and allow 5 minutes for stabilization/warm-up.

1. Access the configuration menus, and use the arrow buttons to scroll to “TRIM OUT”.
2. Press SELECT to access the menu. The “TRIM ZERO” screen will be displayed.
3. Use the arrow buttons to choose the level, zero or full scale, that is to be trimmed.
4. Press SELECT to begin the trim process.
5. While monitoring the reading on the meter, use the arrow buttons to adjust the output to the desired level. Use the meter in the setup to monitor the output as the output is adjusted.
6. When the output is set as desired, press SELECT. This sets the adjustment into SPA memory, and brings up either the next output level to be adjusted (repeat steps 3, 4, and 5), or “EXIT OUT” if both zero and full scale output have been adjusted.
7. To exit the menu, press SELECT when “EXIT OUT” is displayed. The unit will return to the Main Menu.

SPA

Site-Programmable Volt & Milliamp Limit Alarm Trips

Figure 14. Scale HLPGR SPA Analog Output (AO-equipped units only)

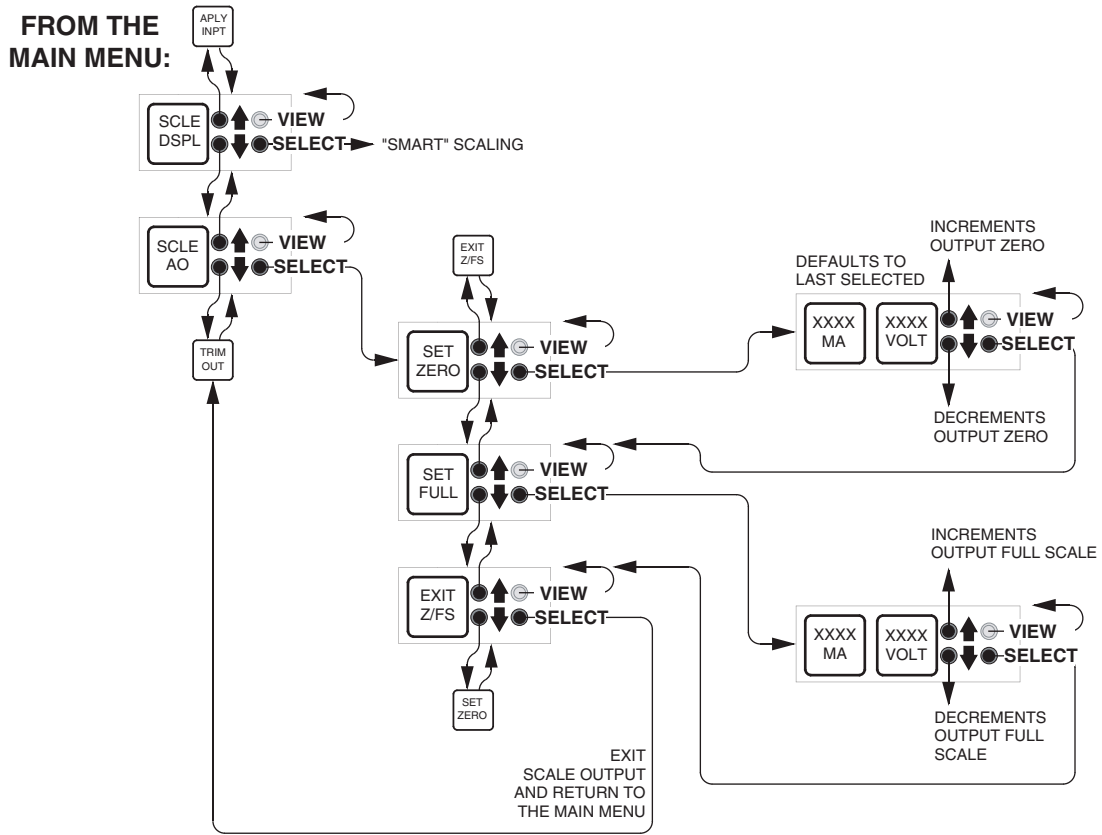

NOTE: RE-RANGING THE UNIT NULLIFIES ANY OUTPUT TRIM. RE-TRIM AFTER ANY RE-RANGING.

Figure 15. Connections for Trimming SPA Output (AO-equipped units only)

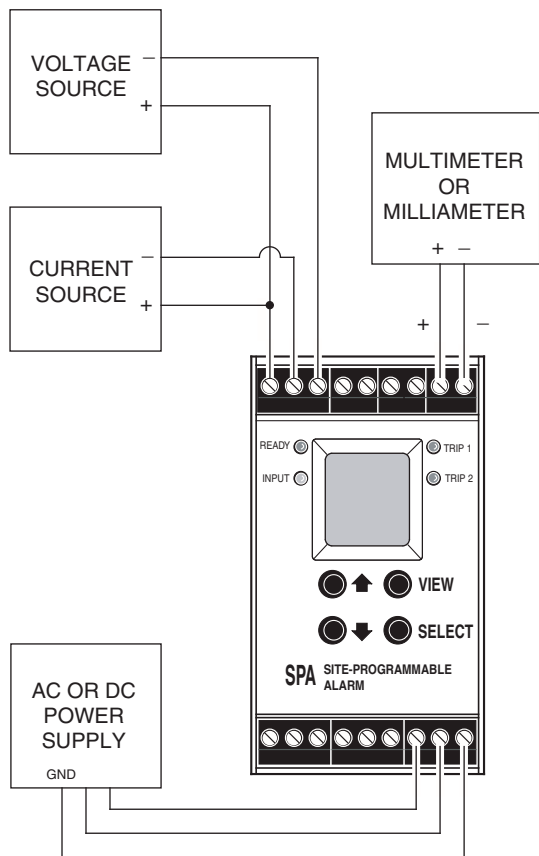
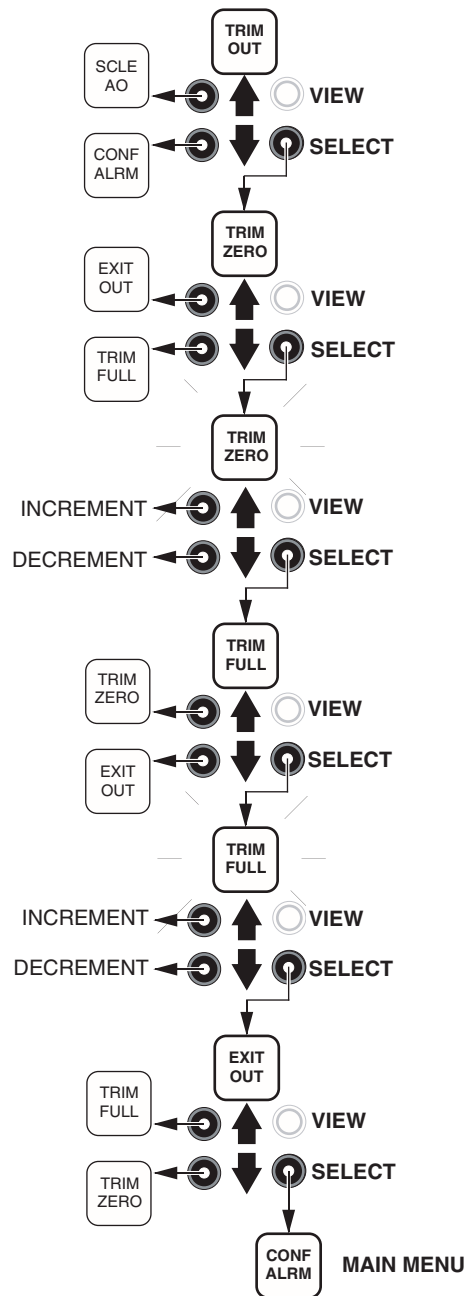

Figure 16. Trimming the SPA Analog Output (AO-equipped units only)



SPA

Site-Programmable Volt & Milliamp Limit Alarm Trips

Configure Alarm(s)

This menu sets:

- Trip Point(s)
- Deadband(s)
- Trip Delay(s)
- High Alarm or Low Alarm Function
- Latching or Non-Latching Operation

Figure 17 gives the menu overview.

1. From the “CONF ALRM” screen of the Main Menu, press SELECT.
2. Press SELECT again to access the settings for the first installed alarm, or use the arrow buttons to access the “ALRM EXIT” screen. Pressing SELECT from “ALRM EXIT” returns to the Main Menu at “PASS WORD”.
3. Use the arrow buttons to scroll through the alarm operation parameters. Press SELECT to access the settings for the displayed parameter.

For convenience, it is recommended that the settings be entered into SPA memory in the order that they come up in this step (shown in Figure 17 from top to bottom):

- Enter/Apply Trip
- Enter Deadband
- Enter Delay
- Set High Alarm or Low Alarm Functioning
- Set Latching or Non-Latching
- Exit

NOTES:

There are two options for setting the trip points of the installed alarms, “ENTR TRIP” and “APLY TRIP”.

In the “ENTR TRIP” menu, the user employs the Smart Ranging feature of the SPA, entering the desired trip point with the front panel push buttons. (Steps 4 through 6)

In the “APLY TRIP” menu, the SPA must be set up with calibration equipment (see Figure 21, page 37). In this, the Standard Ranging procedure, the unit “captures” its trip point from the input of an adjustable source. (Steps 7 through 14)

ENTER TRIP

If the value of the trip point is known, use this, the Smart Ranging feature, of the SPA to program the value into SPA memory. If the trip point is not known, or cannot be entered numerically, skip to step 7, APPLY TRIP.

4. From “ENTR TRIP” in step 3, press SELECT.

NOTE:

When the HLPRG is in Linear Mode, the display will show either mA or V. When in Custom Mode, the display will show the engineering units set in the CONF OPTS menu, Figure 8.

5. Use the arrow buttons to ramp the display to the trip point value, and press SELECT. This enters the displayed value into SPA memory, and brings up the “ENTR DB” (enter deadband) display.
6. Skip to step 14.

Figure 17. Configuring the HLPGR SPA Alarms

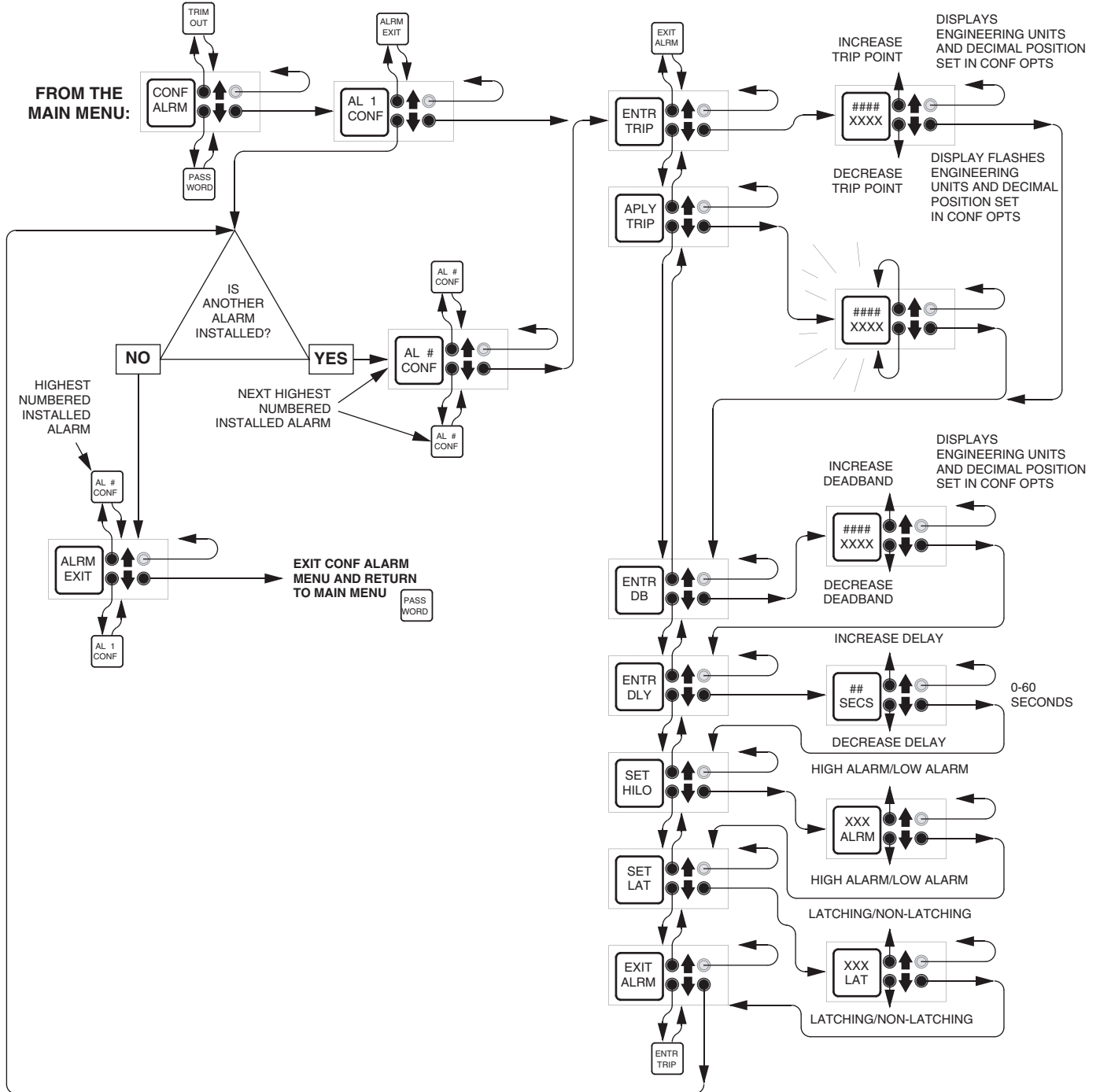

SPA

Site-Programmable Volt & Milliamp Limit Alarm Trips

APPLY TRIP

A signal can be applied to the input terminals of the SPA, using the setup shown in Figure 10. With this setup and the following procedure, the unit can “capture” the desired trip point.

7. Install the SPA being configured into the setup shown in the figure, apply appropriate power, and allow approximately 5 minutes for stabilization/warm-up.
8. Access the configuration menus, and use the down arrow to access the “CONF ALRM” menu.
9. Press SELECT.
10. Use the arrow buttons to access “APLY TRIP”.
11. Press SELECT. The display will flash the input level present at the terminals.
12. Adjust the input to the desired trip point level.
13. Press SELECT when the flashing value on the display reaches the desired trip point value. This stores the value in SPA memory and returns the unit to the Alarm Configuration menu at the “ENTR DB” (enter deadband) screen.

Disconnect the SPA from the input.

14. Press SELECT to access the deadband setting screen, or use the arrow buttons to scroll through the other alarm operating parameters. Press SELECT to access the screen(s) for the parameter displayed, or scroll to “EXIT ALRM” and press SELECT to access the menus for another alarm (if installed), or to return to the Main Menu.

ENTER DEADBAND

15. From the “ENTR DB” screen, press SELECT.
16. Use the arrow buttons to increase or decrease the deadband around the trip point in SPA memory. The display will show the value in the engineering units selected in the “CONF OPTS” menu, discussed earlier.
17. Press SELECT when the display shows the desired deadband value. This returns the unit to the Alarm Configuration menu at the “ENTR DLY” (enter response delay) screen.
18. Press SELECT to access the delay setting screen, or use the arrow buttons to scroll through the other alarm operating parameters. Press SELECT to access the screen(s) for the parameter displayed, or scroll to “EXIT ALRM” and press SELECT to access the menus for another alarm (if installed), or to return to the Main Menu.

ENTER DELAY

19. From the “ENTR DLY” screen, press SELECT.
20. Use the arrow buttons to change the amount of delay time between the input’s exceeding the trip point setting and the actual state change of the alarm. Settings from 0 to 60 seconds are available in 1 second increments.
21. Press SELECT when the display shows the desired delay setting. This returns the unit to the Alarm Configuration menu at “SET HILO” (choose high or low alarm function).

22. Press SELECT to access the high/low setting screen, or use the arrow buttons to scroll through the other alarm operating parameters. Press SELECT to access the screen(s) for the parameter displayed, or scroll to "EXIT ALRM" and press SELECT to access the menus for another alarm (if installed), or to return to the Main Menu.

SET HI/LO

23. From the "SET HILO" screen, press SELECT.
24. Use the arrow buttons to toggle the alarm function between high alarm operation (trips when input exceeds the trip point setting) and low alarm operation (trips when input drops below the trip point).
25. Press SELECT when the display shows the desired setting. This returns the unit to the Alarm Configuration menu at "SET LAT" (choose latching or non-latching alarm function).
26. Press SELECT to access the latch/no latch setting screen, or use the arrow buttons to scroll through the other alarm operating parameters. Press SELECT to access the screen(s) for the parameters displayed, or scroll to "EXIT ALRM" and press SELECT to access the menus for another alarm (if installed), or to return to the Main Menu.

SET LATCHING/NON-LATCHING

27. From the "SET LAT" screen, press SELECT.
28. Use the arrow buttons to toggle the alarm function between latching (alarm stays tripped until input returns to normal (allowing for any deadband) **AND** unit is manually reset) and non-latching (alarm returns to normal as soon as input returns to normal, allowing for any deadband) function.
29. Press SELECT when the display shows the desired setting. This returns the unit to the Alarm Configuration menu at "EXIT ALRM".
30. Press SELECT to bring up the menu for the next installed alarm. If no additional alarms are installed, or to return to the Main Menu, press SELECT from "EXIT ALRM".

To set the operating parameters for the next installed alarm, use the arrow buttons from the "EXIT ALRM" screen to display the next alarm, "AL2 CONF", for example, and press SELECT, and return to step 3.

When all of the alarm parameters for all of the installed alarms have been set as desired, press SELECT from "EXIT ALRM", and press SELECT again from "ALRM EXIT". This returns the unit to the Main Menu at "PASS WORD"

SPA

Site-Programmable Volt &
Milliamp Limit Alarm Trips

Change the Security Password Code

This menu is active when the Security Jumper is NOT installed, or when the jumper is installed and a correct password has been entered. When the jumper is installed, unless the correct password is entered, accessing this menu causes the “PASS LOCK” message to appear. Any attempt to make changes will be “locked out” (READ ONLY mode).

Figure 18 shows the menu.

1. From the “PASS WORD” screen, press SELECT to access “## PASS”.
2. Use the arrow buttons to increment or decrement the password number to be stored in unit memory.
3. Press SELECT when the desired password number is displayed. This returns the user to the Main Menu.

NOTES:

The password can be any number between 00 AND 99.

When the security jumper (Figure 3) is NOT installed, pressing SELECT from “PASS WORD” shows the current password setting.

Figure 18. Changing the HLPRG SPA Password Code

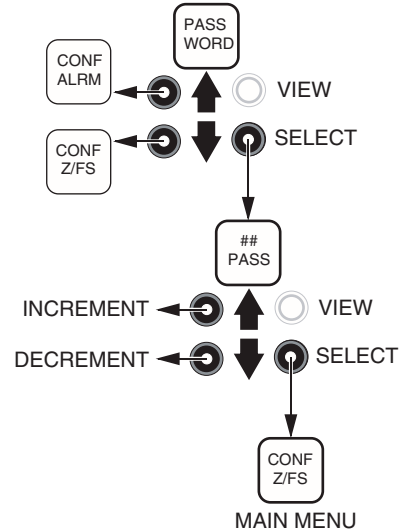

Installation

The SPA is housed in a universal DIN-style case. Its back panel is equipped with fittings that make it possible to mount the unit on both G-type and Top Hat rails.

Figure 19 shows the unit dimensions, including the sizes for dual- and triple/quad-alarm SPAs.

Mounting

To mount the SPA on Top Hat DIN-rail, seat the upper extrusion on the unit back panel over the top lip of the rail and pivot downward until the housing locks into place.

To mount the unit on G-type rail, seat the extrusion under the top lip of the rail and again, pivot downward.

When mounting SPAs in multiple unit scenario like a rack or cabinet, make sure to allow adequate vertical spacing for pivoting the units.

Figure 19. The Dimensions of the SPA

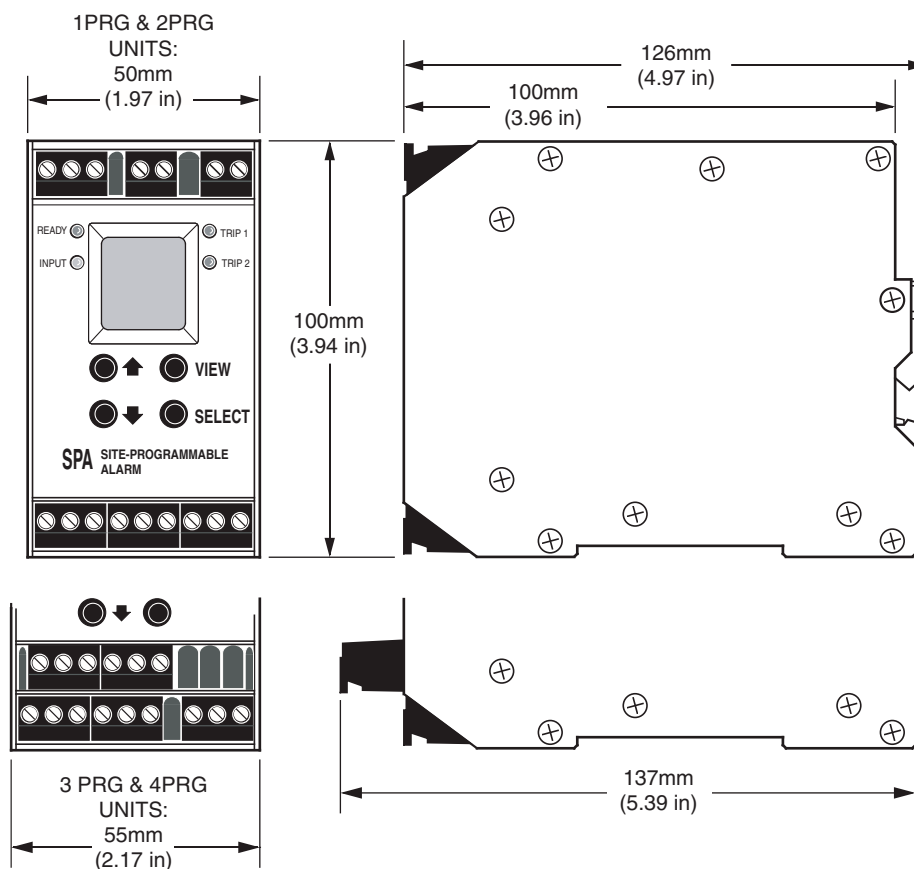

NOTE: All units with the -DPDT option will have the same dimensions as the 3PRG/4PRG units

SPA

Site-Programmable Volt & Milliamp Limit Alarm Trips

Figure 20. Connections for the HLPRG SPA

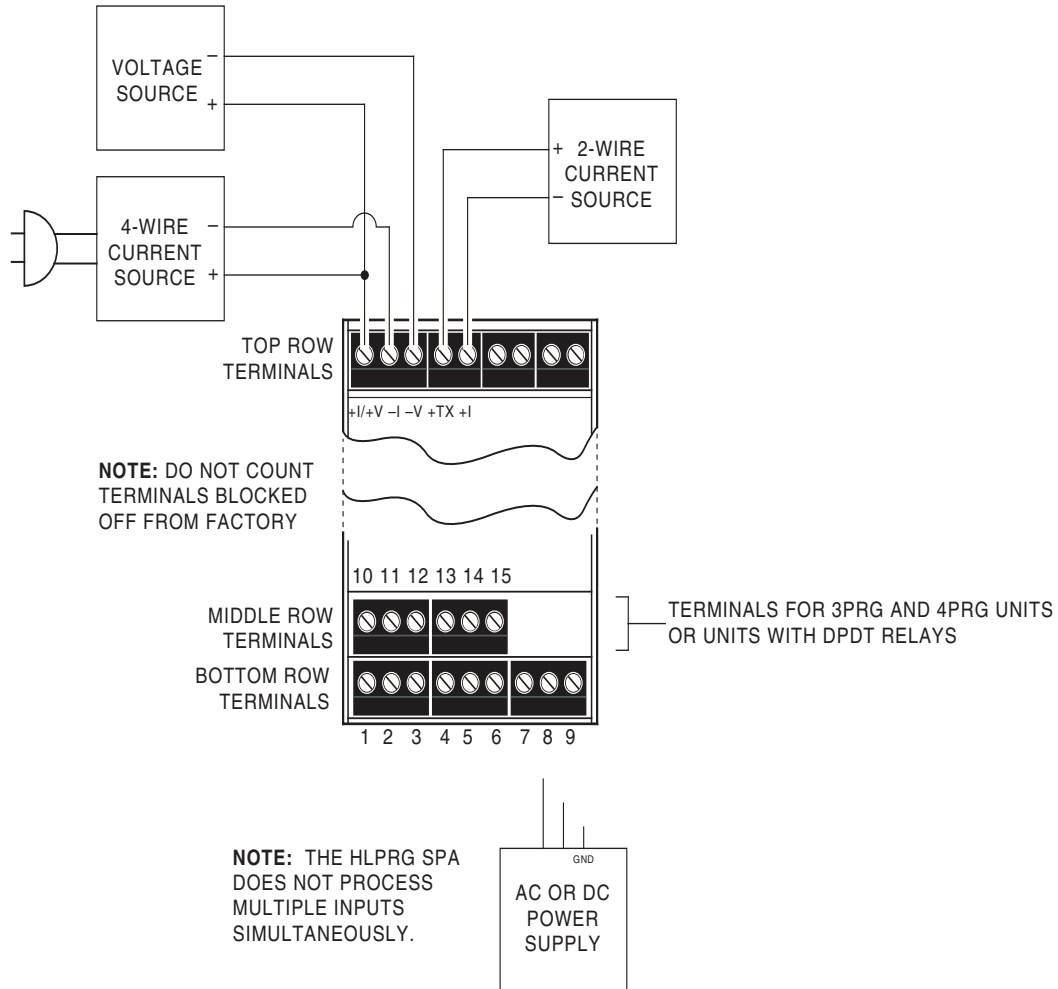

Connections

Figure 20 shows HLPRG input connections. Table 1 gives terminal designations.

Table 2. Terminals for the SPA

Top Row Terminals	T1	T2	T3	T4	T5	T6	T7	T8	T9
High Level SPA	+I/+V	-I	-V	+TX (Note 2)	+I (Note 2)	MR	MR	+Analog OUT (Note 1)	-Analog OUT (Note 1)
Middle Row Terminals	10	11	12	13	14	15			
1 and 2 Relays (1PRG and 2PRG)	Not Present								
3 Relays (3PRG)	NO3	CM3	NC3	Not Present					
4 Relays (4PRG)	NO3	CM3	NC3	NO4	CM4	NC4			
1DPDT Relay	NO2	CM2	NC2	Not Present					
	Relay 1(above)								
2 DPDT Relays	NO2	CM2	NC2	NO2	CM2	NC2			
	Relay 1(above)			Relay 2(above)					
Bottom Row Terminals	B1	B2	B3	B4	B5	B6	B7	B8	B9
1 Relay (1PRG)	NO	CM	NC	NA	NA	NA	POWER AC or DC	POWER AC or DC	GND
2 Relays (2PRG)	NO1	CM1	NC1	NO2	CM2	NC2			
3 Relays (3PRG)	NO1	CM1	NC1	NO2	CM2	NC2			
4 Relays (4PRG)	NO1	CM1	NC1	NO2	CM2	NC2			
1DPDT Relay	NO1	CM1	NC1	Not Present					
	Relay 1(above)								
2 DPDT Relays	NO1	CM1	NC1	NO1	CM1	NC1			
	Relay 1(above)			Relay 2(above)					

NOTES:

1. When AO option is installed.
2. Use when the SPA is to provide power for 2-wire, loop-powered input devices.
3. When determining the terminal designations, terminals blocked off from the factory should not be counted.

SPA

Site-Programmable Volt & Milliamp Limit Alarm Trips

Operation

Once connected to sensors, annunciators (or other discrete devices), and appropriate power, the SPA begins to function according to its internal switch settings and the configuration stored in its non-volatile internal memory.

Configuration data, stored in memory, is monitored continuously. Changes can be made at any time. Any changes made to operating parameters controlled by choices made in the SPA menu system take effect immediately.

The settings of the internal DIP switches and security jumper may also be changed at any time. Changes to the security jumper setting, however, do not take effect until unit power is cycled off and on.

The settings for failsafe/non-failsafe and source/sink (see Figures 3 and 4, respectively), once made, take effect right away.

LEDs

There are at least three, and as many as six LEDs on the front panel of the SPA. Each is labeled, and provides a quick reference for input condition during normal unit operations.

- **READY** This LED shows green during normal operation. Green indicates that the SPA has run its startup diagnostic and that all internal circuitry is functioning properly.

The LED goes out if internal errors occur.

- **INPUT** This LED shows green during normal operation. Green indicates that an input sensor or sensors has/have been connected, and that they are functioning properly.
- **TRIP #** These LEDs, one per installed relay, show green when the connected input is in a non-alarm condition relative to the trip point setting. A red LED indicates alarm.

NOTE:

The state of the SPA relays in alarm or non-alarm is determined by the failsafe/non-failsafe setting of the unit's internal DIP switches (see Figure 3, earlier in this manual). Do not confuse the state of the LED with the state of its associated relay.

Failsafe relays are ON (energized) when input is in a non-alarm condition (green LED), OFF (de-energized) in alarm (red LED).

Non-failsafe relays are ON (energized) when input is in an alarm condition (red LED), OFF (de-energized) in non-alarm (green LED).

This design scheme means that the LEDs associated with relays will always show red when the corresponding input is in an alarm condition, green in non-alarm.

Manual Reset

There are two connections labeled "MR" on the SPA top terminal block. These terminals work in conjunction with the latching/non-latching alarm function.

When an SPA is configured with latching alarms (refer to the description of the "CONF ALRM" menu, earlier in this manual), an alarm condition will not "clear", that is, the relay will not change state, until the input returns to a non-alarm state **AND** these manual reset terminals are shorted and then opened.

Shorting and then opening the MR terminals "clears" all alarms.

Error Codes

Every SPA is subjected to an exhaustive battery of operational checks and tests prior to its shipment. Occasionally, however, units can sustain damage getting from the factory to the user.

As a safeguard, the unit is equipped with a full set of internal diagnostics that check operation and configuration on power-up. If there are problems with the microprocessor, or with conflicting operating parameter settings, the LCD will show an error code upon unit start-up.

Table 2 lists the error codes.

For most of these problems, it will be necessary to return the offending SPA to the factory.

Table 2. SPA LCD Error Codes

Error Message	What it Means	What to Do
EE FLT	EEPROM Error - The internal processor failed	Cycle power to the unit, and if the error occurs again, return the unit to the factory for service.
RAM ERR	RAM(memory) Error - The internal processor failed	
ROM ERR		
CAL ERR	Calibration Error - The factory-set calibration of the unit has failed to initialize.	
DATA ERR	Data Error - There are conflicts in the settings entered into unit memory. This can be caused by power loss or fluctuation during power-up.	Cycle power to the unit, then run through the configuration menus to ensure that the technician made the correct sensor selections for the range settings, etc.
PACT ERR	Memory Packet Failure - Internal memory failure	Cycle power to the unit, and if the error occurs again, return the unit to the factory for service.
CONF ERR	Data Error - There are conflicts in the settings entered into unit memory. This can be caused by power loss or fluctuation during power-up.	Cycle power to the unit, then run through the configuration menus to ensure that the technician made the correct sensor selections for the range settings, etc.
RJC OPEN	Reference Junction Compensation Resistor Burnout.	Cycle power to the unit, and if the error occurs again, return the unit to the factory for service.
TABL ERR	Internal Table Error - The linearization curve programming is not correct.	Make sure that the endpoints of the programmed curve are within the selected INPUT SCALING.

Customer Service

If service assistance is ever required for one of the SPAs in your application, refer to the inside of the back cover of this manual for the telephone numbers to Moore Industries STAR Center customer service department.

If possible, make a note of the model number of the offending unit before calling. For fastest assistance, try to gather information on the unit(s) serial number and the job and purchase order number under which it was shipped.



Declaration of Conformity

EMC Directive 89/336/EEC



Manufacturer's Name: Moore Industries-International, Inc.
Manufacturer's Address: 16650 Schoenborn Street
 North Hills, CA 91343-6196
 USA

Declares that the product(s):

Product Name: SPA-CE

	<u>MODEL</u>	<u>INPUT</u>	<u>OUTPUT</u>	<u>POWER</u>	<u>OPTIONS</u>	<u>HOUSING</u>
Model Number(s):	SPA	*	*	117VAC	- CE ¹	*
	SPA	*	*	230VAC	- CE ¹	*
	SPA	*	*	**24VDC	- CE ¹	*

*Indicates any input, output, option and housing as stated on the product data sheet.
 ** Indicates any power between 22VDC and 50VDC.

Conforms to the following EMC specifications:

- EN50081-1, 1992, Generic Emissions Standard, Residential, Commercial and Light Industry.
- EN50082-1, 1992, Generic Immunity Standard, Residential, Commercial and Light Industry.
- EN61010-1, 1995, Safety requirements for electrical equipment for measurement and control use.

Supplemental Information:

¹ CE option is required.

March 21, 2001
Date

Fred Adt
Quality Assurance Director

Robert Stockham
Moore Industries-International, Inc.

European Contact: Your Local Moore Industries Sales and Service Office

The Interface Solution Experts • www.miinet.com



United States • info@miinet.com
 Tel: (818) 894-7111 • FAX: (818) 891-2816
 Australia • sales@mooreind.com.au
 Tel: (02) 8536-7200 • FAX: (02) 9525-7296

Belgium • info@mooreind.be
 Tel: 03/448.10.18 • FAX: 03/440.17.97
 The Netherlands • sales@mooreind.nl
 Tel: (0)344-617971 • FAX: (0)344-615920

China • sales@mooreind.sh.cn
 Tel: 86-21-62481120 • FAX: 86-21-62490635
 United Kingdom • sales@mooreind.com
 Tel: 01293 514488 • FAX: 01293 536852

RETURN PROCEDURES

To return equipment to Moore Industries for repair, follow these four steps:

1. Call Moore Industries and request a Returned Material Authorization (RMA) number.

Warranty Repair –

If you are unsure if your unit is still under warranty, we can use the unit's serial number to verify the warranty status for you over the phone. Be sure to include the RMA number on all documentation.

Non-Warranty Repair –

If your unit is out of warranty, be prepared to give us a Purchase Order number when you call. In most cases, we will be able to quote you the repair costs at that time. The repair price you are quoted will be a "Not To Exceed" price, which means that the actual repair costs may be less than the quote. Be sure to include the RMA number on all documentation.

2. Provide us with the following documentation:
 - a) A note listing the symptoms that indicate the unit needs repair
 - b) Complete shipping information for return of the equipment after repair
 - c) The name and phone number of the person to contact if questions arise at the factory
3. Use sufficient packing material and carefully pack the equipment in a sturdy shipping container.
4. Ship the equipment to the Moore Industries location nearest you.

The returned equipment will be inspected and tested at the factory. A Moore Industries representative will contact the person designated on your documentation if more information is needed. The repaired equipment, or its replacement, will be returned to you in accordance with the shipping instructions furnished in your documentation.

WARRANTY DISCLAIMER

THE COMPANY MAKES NO EXPRESS, IMPLIED OR STATUTORY WARRANTIES (INCLUDING ANY WARRANTY OF MERCHANTABILITY OR OF FITNESS FOR A PARTICULAR PURPOSE) WITH RESPECT TO ANY GOODS OR SERVICES SOLD BY THE COMPANY. THE COMPANY DISCLAIMS ALL WARRANTIES ARISING FROM ANY COURSE OF DEALING OR TRADE USAGE, AND ANY BUYER OF GOODS OR SERVICES FROM THE COMPANY ACKNOWLEDGES THAT THERE ARE NO WARRANTIES IMPLIED BY CUSTOM OR USAGE IN THE TRADE OF THE BUYER AND OF THE COMPANY, AND THAT ANY PRIOR DEALINGS OF THE BUYER WITH THE COMPANY DO NOT IMPLY THAT THE COMPANY WARRANTS THE GOODS OR SERVICES IN ANY WAY.

ANY BUYER OF GOODS OR SERVICES FROM THE COMPANY AGREES WITH THE COMPANY THAT THE SOLE AND EXCLUSIVE REMEDIES FOR BREACH OF ANY WARRANTY CONCERNING THE GOODS OR SERVICES SHALL BE FOR THE COMPANY, AT ITS OPTION, TO REPAIR OR REPLACE THE GOODS OR SERVICES OR REFUND THE PURCHASE PRICE. THE COMPANY SHALL IN NO EVENT BE LIABLE FOR ANY CONSEQUENTIAL OR INCIDENTAL DAMAGES EVEN IF THE COMPANY FAILS IN ANY ATTEMPT TO REMEDY DEFECTS IN THE GOODS OR SERVICES, BUT IN SUCH CASE THE BUYER SHALL BE ENTITLED TO NO MORE THAN A REFUND OF ALL MONIES PAID TO THE COMPANY BY THE BUYER FOR PURCHASE OF THE GOODS OR SERVICES.

ANY CAUSE OF ACTION FOR BREACH OF ANY WARRANTY BY THE COMPANY SHALL BE BARRED UNLESS THE COMPANY RECEIVES FROM THE BUYER A WRITTEN NOTICE OF THE ALLEGED DEFECT OR BREACH WITHIN TEN DAYS FROM THE EARLIEST DATE ON WHICH THE BUYER COULD REASONABLY HAVE DISCOVERED THE ALLEGED DEFECT OR BREACH, AND NO ACTION FOR THE BREACH OF ANY WARRANTY SHALL BE COMMENCED BY THE BUYER ANY LATER THAN TWELVE MONTHS FROM THE EARLIEST DATE ON WHICH THE BUYER COULD REASONABLY HAVE DISCOVERED THE ALLEGED DEFECT OR BREACH.

RETURN POLICY

For a period of thirty-six (36) months from the date of shipment, and under normal conditions of use and service, Moore Industries ("The Company") will at its option replace, repair or refund the purchase price for any of its manufactured products found, upon return to the Company (transportation charges prepaid and otherwise in accordance with the return procedures established by The Company), to be defective in material or workmanship. This policy extends to the original Buyer only and not to Buyer's customers or the users of Buyer's products, unless Buyer is an engineering contractor in which case the policy shall extend to Buyer's immediate customer only. This policy shall not apply if the product has been subject to alteration, misuse, accident, neglect or improper application, installation, or operation. THE COMPANY SHALL IN NO EVENT BE LIABLE FOR ANY INCIDENTAL OR CONSEQUENTIAL DAMAGES.



WORLDWIDE • www.miinet.com

United States • info@miinet.com
Tel: (818) 894-7111 • FAX: (818) 891-2816

Australia • sales@mooreind.com.au
Tel: (02) 8536-7200 • FAX: (02) 9525-7296

Belgium • info@mooreind.be
Tel: 03/448.10.18 • FAX: 03/440.17.97

The Netherlands • sales@mooreind.nl
Tel: (0)344-617971 • FAX: (0)344-615920

China • sales@mooreind.sh.cn
Tel: 86-21-62491499 • FAX: 86-21-62490635

United Kingdom • sales@mooreind.com
Tel: 01293 514488 • FAX: 01293 536852

January 2006

The information contained within this document affects the following user's manuals: SPA (HLPRG) 224-715-00, Revision B and SPA HART, 224-741-00, Revision D.

This supplement has been issued to provide Transmitter Excitation (TX) Power Supply information and specifications which were not included in the SPA (HLPRG) and SPA HART User's Manuals.

Power Supply:

U (Universal): 22-300Vdc or 90-260Vac

CE Unit: 117Vac or 230Vac, $\pm 10\%$, 47-63Hz.

The CE version is built to order. A change in the voltage requires a change in fuse value.

Power Consumption:

U (Universal): 2 to 3W, nominal, including use of TX

CE Unit: 2.5 to 4W, nominal, including use of TX

TX Power Output:

Transmitter excitation power of 24Vdc, $\pm 10\%$ @ 24mA is provided at the terminals marked *TX*.