

A Division of Systems, Inc.

POWERAMP[®]

Premium Loading Dock Systems

EH SERIES

Dock Leveler

Owner's/User's Manual



POWERAMP • Division of Systems, Inc. • W194 N11481 McCormick Drive • Germantown, WI 53022
800.643.5424 • fax: 262.255.5917 • www.docksystemsinc.com • techservices@docksystemsinc.com

Table of Contents

| | Page |
|--|------------|
| Safety | |
| Recognize Safety Information | 1 |
| General Operational Safety Precautions | 1 |
| Operational Safety Precautions..... | 2 |
| Maintenance Safety Precautions..... | 4 |
| Safety Decal's..... | 5 |
| Owner's User's Responsibilities | 6 |
| | |
| Introduction | |
| General Information..... | 7 |
| Dock Leveler Stock Specifications | 7 |
| Component Identification..... | 8 |
| Theory | 8 |
| | |
| Installation | |
| Placard Instructions | 9 |
| Prepare Pit | 10 |
| Prepare Dock Leveler | 11 |
| Install Dock Leveler | 12 |
| Install Control Panel and Wiring | 18 |
| Put New Leveler Into Service..... | 19 |
| | |
| Operation | |
| Operating Instructions | 20 |
| Ramp Loading/Unloading Instructions | 21 |
| End Loading/Unloading Instructions | 22 |
| | |
| Maintenance | |
| Service Dock Leveler Safely..... | 23 |
| Periodic Maintenance | 24 |
| | |
| Adjustments | |
| Valve Adjustment Procedure..... | 27 |
| Adjust Auto Return To Dock (ARTD)..... | 30 |
| | |
| Troubleshooting | |
| Troubleshooting..... | 33 |
| | |
| Parts | |
| Controls | 37 |
| Frame and Platform | 38 |
| Hydraulic Components..... | 40 |
| Power Pack Assembly..... | 42 |
| Operation Instruction | 46 |
| Weather Seal | 47 |
| | |
| Miscellaneous | |
| Electrical Diagram..... | 48 |
| Customer Information | 49 |
| Warranty..... | Back Cover |

Recognize Safety Information

Safety-Alert Symbol



The Safety-Alert Symbol identifies important safety messages on equipment, safety signs, in manuals, or elsewhere. When you see this symbol, be alert to the possibility of personal injury or death. Follow the instructions in the safety message.

DANGER

The use of the word DANGER signifies the presence of an extreme hazard or unsafe practice which will most likely result in severe injury or death.

WARNING

The use of the word WARNING signifies the presence of a serious hazard or unsafe practice which may result in serious injury or death.

CAUTION

The use of the word CAUTION signifies possible hazard or unsafe practice which could result in personal injury.

IMPORTANT

The use of the word IMPORTANT is to draw attention to a procedure that needs to be followed to prevent machine damage.

General Operational Safety Precautions

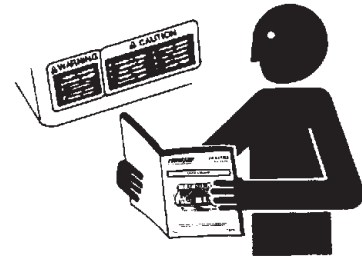

Read and understand the operating instructions and become thoroughly familiar with the equipment and its controls before operating the dock leveler.

Never operate a dock leveler while a safety device or guard is removed or disconnected.

Never remove DANGER, WARNING, or CAUTION signs or Decal's on the equipment unless replacing them.

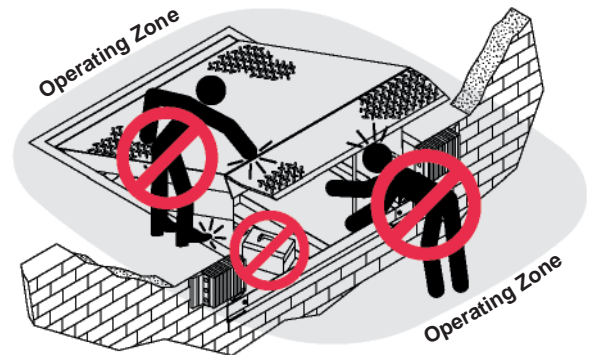

Do not start the equipment until all unauthorized personnel in the area have been warned and have moved outside the operating zone.

Remove any tools or foreign objects from the operating zone before starting.

Keep the operating zone free of obstacles that could cause a person to trip or fall.

SAFETY

Operational Safety Precautions



Learn the safe way to operate this equipment. Read and understand the manufacturer's instructions. If you have any questions, ask your supervisor.

DANGER



Stay clear of dock leveling device when transport vehicle is entering or leaving area.



Do not move or use the dock leveling device if anyone is under or in front of it.



Keep hands and feet clear of pinch points. Avoid putting any part of your body near moving parts.

WARNING

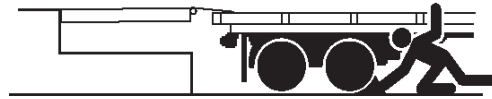

Chock/restrain all transport vehicles. Never remove the wheel chocks until loading or unloading is finished and driver has been given permission to drive away.



Do not use a broken or damage dock leveling device. Make sure proper service and maintenance procedures have been performed before using.

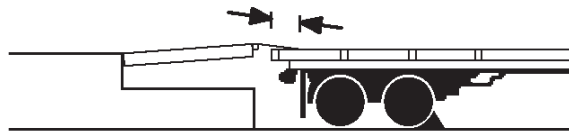

Make sure lip overlaps onto the transport vehicles trailer at least 4 in. (102 mm).

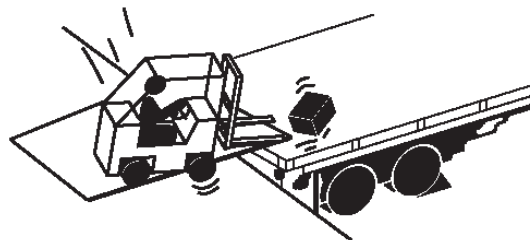

Keep a safe distance from both side edges.

⚠ WARNING

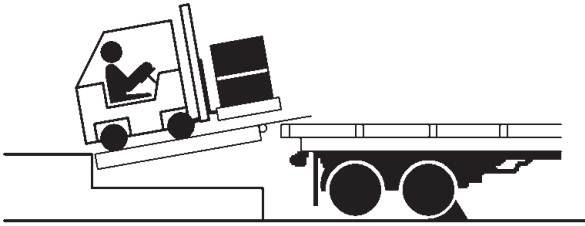

Do not use dock leveling device if transport vehicle is too high or too low.

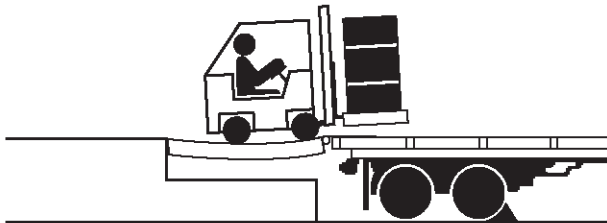

Do not overload the dock leveling device.

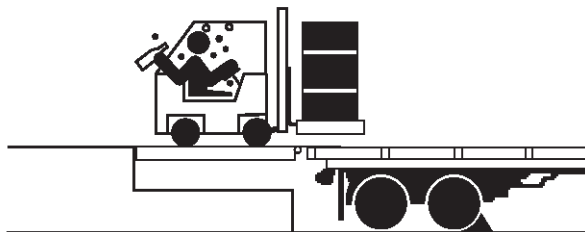

Do not operate any equipment while under the influence of alcohol or drugs.

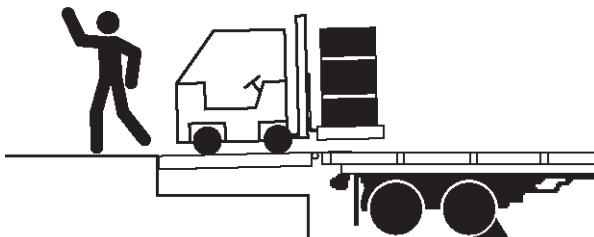

Do not leave equipment or material unattended on dock leveling device.

SAFETY

Maintenance Safety Precautions

DANGER

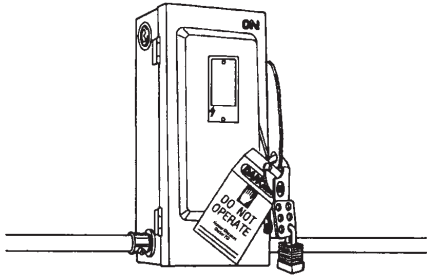

Hydraulic and electrical power must be OFF when servicing the equipment. For maximum protection, use an OSHA approved locking device to lock out all power sources. Only the person servicing the equipment should have the key to unlock the device.

CAUTION



Always post safety warnings and barricade the work area at dock level and ground level to prevent unauthorized use of the unit before maintenance is complete.

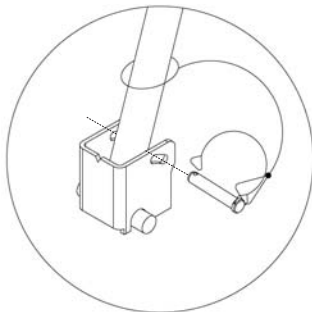

The maintenance prop must be in the upright "service" position when working under the dock leveler. For maximum protection, use an OSHA approved locking device to lock the maintenance prop in the service position. Only the person servicing the equipment should have the key to unlock the device.

WARNING

ALWAYS disconnect electrical power source and ground wire before welding on dock leveler.

DO NOT ground welding equipment to any hydraulic or electrical components of the dock leveler. Always ground to the dock leveler frame.

Failure to follow these instructions may result in damage to dock leveler and/or serious personal injury or death.

WARNING

DO NOT grind or weld if hydraulic fluid or other flammable liquid is present on the surface to be ground or welded

DO NOT grind or weld if uncontained hydraulic fluid or other flammable liquid is present. Stray sparks can ignite spills or leaks near the work area. Always clean up the oil leaks and spills before proceeding with grinding or welding.

Always keep a fire extinguisher of the proper type nearby when grinding or welding.

Failure to follow these instructions may result in serious personal injury or death.

WARNING

ALWAYS stand clear of dock leveler lip when working in front of the dock leveler. Failure to do this may result in serious personal injury or death.

DANGER



Arc Flash and Shock Hazard
PPE (Personal Protection Equipment) Required

De-energize equipment before working on or inside. Do not open cover without appropriate PPE. Refer to NFPA 70E for PPE requirements. This panel may contain more than one power source.

Hazardous Voltage
Will Cause Severe
Injury or Death

Safety Decal's

Every 90 days (quarterly) inspect all safety labels and tags to ensure they are on the dock leveler and are easily legible. If any are missing or require replacement, please call 1-800-643-5424 for replacements.

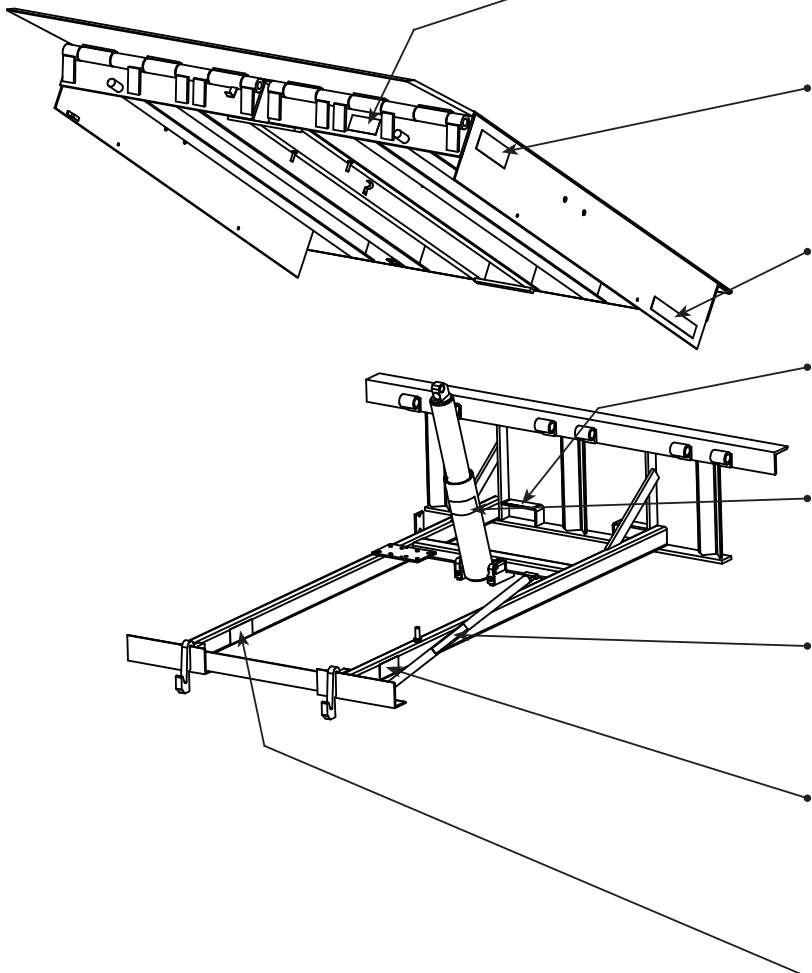

| | |
|---|--|
| <p>1751-0727</p> | |
| <p>1751-0730 (x2)</p> | |
| <p><i>(decal placed in same position on both sides)</i></p> | |
| <p>1751-0329 (x2)</p> | |
| <p><i>(decal placed in same position on both sides)</i></p> | |
| <p>1751-0330 (x2)</p> | |
| <p><i>(decal placed in same position on both sides)</i></p> | |
| <p>1751-0138</p> | |
| <p>1751-0729</p> | |
| <p>1751-0731</p> | |
| <p>1751-0726</p> | |

OWNER'S/USER'S RESPONSIBILITIES

1. The owner/ user should recognize the inherent dangers of the interface between the loading dock and the transportation vehicle. The owner/ user should, therefore, train and instruct all operators in the safe operation and use of the loading dock equipment in accordance with manufacturer's recommendations and industry standards. Effective operator training should also focus on the owner's/user's company policies and operating conditions. Maintaining, updating and re training all operators on safe working habits and operation of the equipment, regardless of previous experience, should be done on a regular basis and should include an understanding and familiarity with all functions of the equipment. Owner's/user's shall actively maintain, update and retrain all operators on safe working habits and operations of the equipment.
2. The manufacturer shall provide to the initial purchaser all necessary information regarding Safety Information, Operation, Installation and Safety Precautions, Recommended Initial and Periodic Inspections Procedures, Planned Maintenance Schedule, Product Specifications, Troubleshooting Guide, Parts Break Down, Warranty Information, and Manufacturers Contact Information, as well as tables to identify the grade(slope) for all variations of length or configuration of the dock leveling device and information identifying the maximum uncontrolled drop encountered when sudden removal of support while in the working range of the equipment.
3. It is recommended that when the transportation vehicle is positioned correctly in the dock opening and in contact with both bumpers, there shall be a minimum of 4.00 inches (100mm) overlap of the leveling device and the transportation vehicle at all times during the loading and unloading process.
4. The Owner/User must review all name plates, placards, decals, instructions and posted warnings and place the same in view of the operator or maintenance personnel for whom such warnings are intended for. Contact manufacturer for any replacements.
5. Manufacturer's recommended periodic maintenance and inspection procedures in effect at the date of shipment shall be followed at all times. Written documentation of maintenance, replacement parts or damage should be retained. In the event of damage notification to the manufacturer is required.
6. Loading dock equipment that has been structurally damaged or has experienced a sudden loss of main support while under load (such as what might occur when a transport vehicle pulls out from under the leveling device) shall be removed from service, inspected by a manufacturer's authorized representative, and repaired or replaced as needed before being placed back in service.
7. Any modifications or alterations of loading dock equipment shall only be done with prior written approval from the manufacturer and the same shall be at least as safe as the original equipment was prior to the modification and shall also satisfy all safety requirements of the manufacturer for the particular application of the leveling device.
8. When industrial moving devices are being used in the loading or unloading of product from the transportation vehicle, this vehicle shall have the brakes and wheel chocks applied appropriately or all other positive restraining device shall be fully utilized. It is recommended that trailers with air-ride suspension systems shall have its air exhausted prior to performing loading and unloading operation to minimize trailer bed drop.
9. Loading dock safety equipment should never be used outside of its intended use, vertical working range, or capacity. Please consult the manufacturer if you have any questions as to the use, vertical working range or capacity of the equipment. Only properly trained and authorized personnel should operate the equipment.
10. When selecting loading dock safety equipment, it is important to consider not only present requirements but also future plans and any possible adverse conditions, environmental factors or usage.

General Information

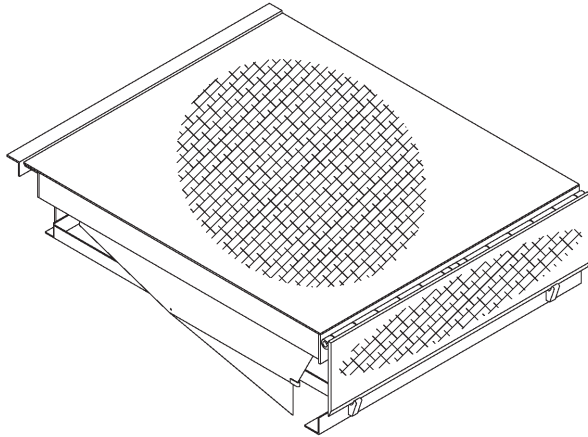

Congratulations on your choice of a Poweramp dock leveler. This manual covers the EH series hydraulic dock leveler.

Designed by Poweramp to be a marvel of simplicity and efficiency, your dock leveler, when properly installed, will provide many years of trouble-free performance with an absolute minimum of maintenance. Its revolutionary hydraulic system efficiently controls and operates every function. To obtain maximum performance and longest possible use, a simple program of preventive maintenance is recommended.

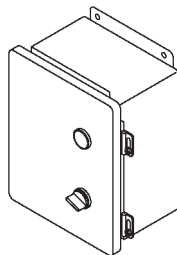

The EH series dock leveler comes equipped with an electrical control panel, which allows pushbutton operation of the dock leveler functions. Each EH dock leveler unit and control panel has been factory prewired and tested to ensure satisfactory operation.

To illustrate which connections are to be made in the field at installation, electrical drawings are included with each order or by contacting Poweramp Technical Services.

Once again, thank you and congratulations on your purchase of a Poweramp hydraulic dock leveler.

Dock Leveler Stock Specifications

EH dock leveler's are available in the following sizes, weight capacities, and options:

Width: EH

- 6 ft (1828.8 mm)
- 6-1/2 ft (1981.2 mm)
- 7 ft (2133.6 mm)

Length

- 6 ft (1828.8 mm)
- 8 ft (2438 mm)
- 10 ft (3048 mm)
- 12 ft (3658 mm)

Capacity (CIR*)

- 25,000 lb (11 340 kg)
- 30,000 lb (13 608 kg)
- 35,000 lb (15 876 kg)
- 40,000 lb (18 144 kg)
- 45,000 lb (20 412 kg)
- 50,000 lb (22 680 kg)
- 60,000 lb (27 216 kg)

* CIR (Comparative Industry Rating)

Call Poweramp to discuss available voltages, phases and options to meet your specific needs.

INTRODUCTION

Component Identification

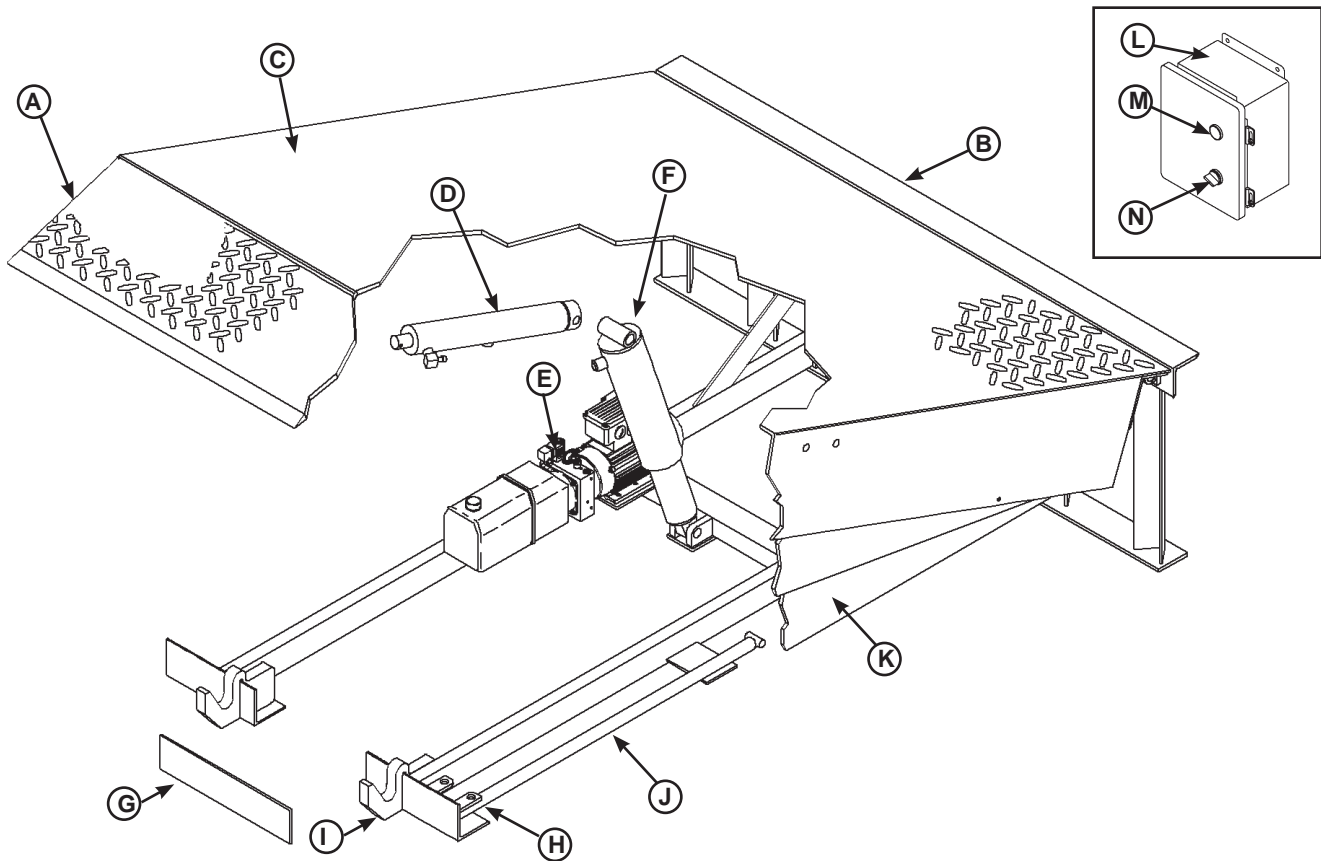

- | | | | |
|------------------|--------------------------------------|-------------------------------|--------------------------|
| A — Lip | E — Powerpack (Motor/Pump/Reservoir) | H — Maintenance Prop Lock-Out | L — Control Box |
| B — Main Frame | F — Platform Cylinder | J — Maintenance Prop | M — Raise Button |
| C — Platform | G — Clean Sweep Removable Section | K — Toe Guards (2 used) | N — ARTD Switch (option) |
| D — Lip Cylinder | | | |

THEORY

The EH dock leveler uses hydraulic logic and one-button operation for ease of use.

The dock leveler can be operated remotely using the RAISE button (M) on the control panel .

Platform (C) is raised by pushing and holding the RAISE button (M). This activates an electric motor (E) which, in turn, drives a hydraulic pump. The hydraulic pump forces oil into the platform cylinder(s) (F), causing the platform to rise. Releasing the RAISE button allows the platform to lower.

When the platform rises to the highest point of travel left in the platform cylinder, a sequence in the Powerpack directs fluid flow to the lip cylinder, extending the lip.

With the lip fully extended, the raise button may be released, allowing the leveler to float down on to the truck for loading or unloading.

**See Operating Instructions for a complete operation guide.*

Placard Installation Instructions

- Owner is responsible for the installation and placement of product placards.
- Make sure placard is in plain view of dock leveler operations.
- Suggested placement of placard is near control box attached to electrical conduit by using nylon tie. If there is no control box present, mount placard on wall to the immediate left of leveler at eye level.

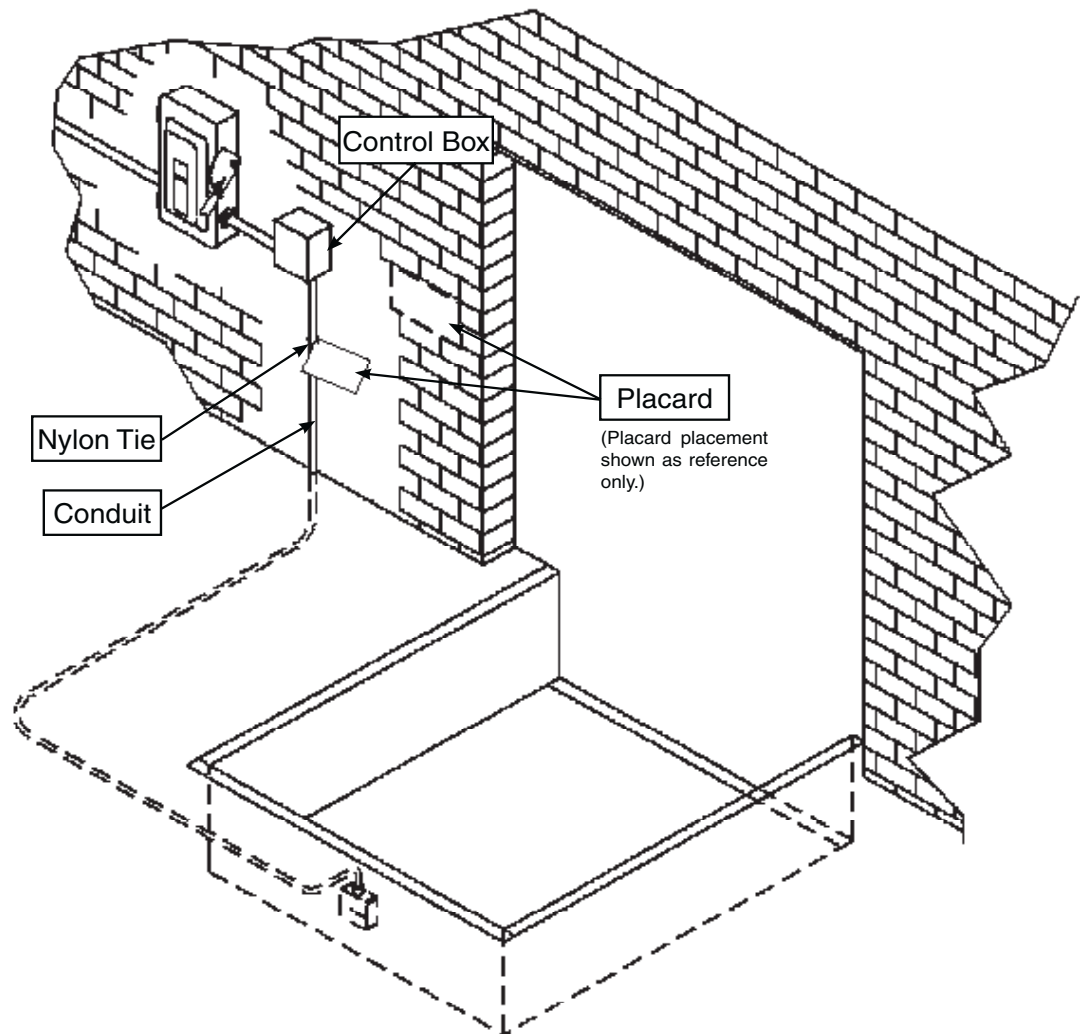

INSTALLATION

Prepare Pit

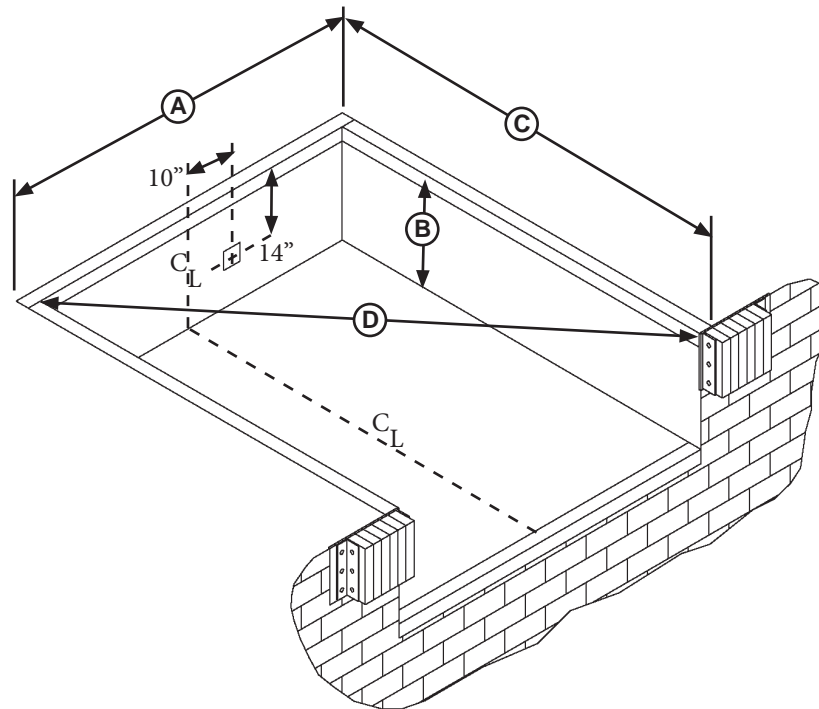

A—Distance (Pit Width) (Front and Rear) B—Distance (Dock Floor-to-Pit Floor) (All Four Corners) C—Distance (Pit Length) (Both Sides of Pit) D—Distance (Pit Corner-to-Corner) (Top, Bottom, and Both Sides)



WARNING

Post safety warnings and barricade the work area at dock level and ground level to prevent unauthorized use of the dock leveler before installation has been completed.

Failure to follow the installation instructions can result in damage to dock leveler, the facilities, and/or serious personal injury or death.



CAUTION

Only trained installation professionals with the proper equipment should install this product.

IMPORTANT

DO NOT remove the shipping bands around the dock leveler lip until instructed to do so.

Before lowering the dock leveler into the pit, the following must be performed:

1. Remove all debris from the pit and sweep the pit clean.
2. Check the entire dock leveler pit for proper construction according to approved/certified pit drawings. Make sure pit is square by making the following measurements:

- Measure pit width distance (A) at both front and rear of pit.
- Measure dock floor-to-pit floor distance (B) at all four corners.
- Measure pit length distance (C) at both sides.
- Measure corner-to-corner (cris-cross) distance (D) at both sides. Take measurements at dock floor level and at pit floor level.

If any measurement is off by more than 1/8 in. (3.18 mm), contact Poweramp Technical Services before proceeding.

3. Make sure the field junction box for the dock leveler (E) is at the correct location per pit diagrams.

Prepare Dock Leveler

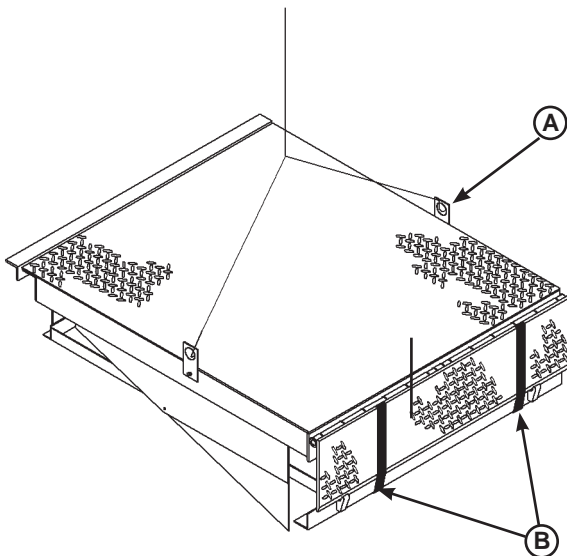

A— Lifting Bracket (2 used)

B — Shipping Bands

Poweramp dock leveler's are designed with installation in mind. Each unit is shipped with lifting brackets (A) fastened to the platform side joists.

WARNING

The dock leveler is heavy. Use a lifting device and chains with the appropriate lifting capacity and reach.

Always use the lifting brackets provided with the unit whenever lowering or lifting a dock leveler into or out of a pit.

Failure to follow these instructions may result in damage to dock leveler and/or serious personal injury or death.

IMPORTANT

DO NOT remove the shipping bands (B) around the platform lip and leveler frame at this time. The shipping bands are needed to hold the leveler together during the installation process.

1. Remove any control panel and bumpers that may be banded to the frame of the dock leveler. DO NOT remove the shipping bands (B) around the platform lip and leveler frame at this time.

IMPORTANT

DO NOT over tighten the lifting bracket hardware. Over tightening can damage the weather seal, if equipped.

NOTE: Overall width of platform and lifting brackets (A) must be kept to a minimum to prevent interference between the lifting brackets and the pit walls as the dock leveler is lowered into the pit.

2. Make sure the mounting hardware of lifting brackets (A) is snug. The brackets should pivot relatively freely on the mounting cap screw. DO NOT over tighten.
3. Attach lifting chains to lifting brackets (A) and to a lifting device (i.e., hoist or fork truck) having the appropriate lifting capacity and reach.
4. Remove wood blocks that are attached to the leveler frame before putting the dock leveler into the pit.

INSTALLATION

Install Dock Leveler

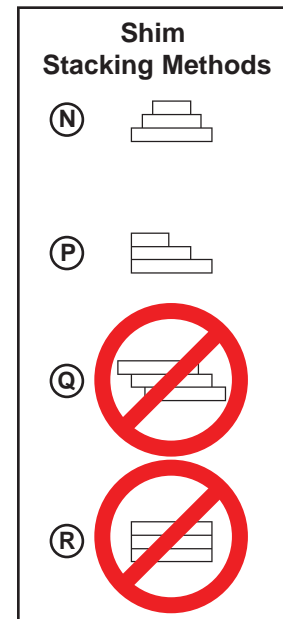
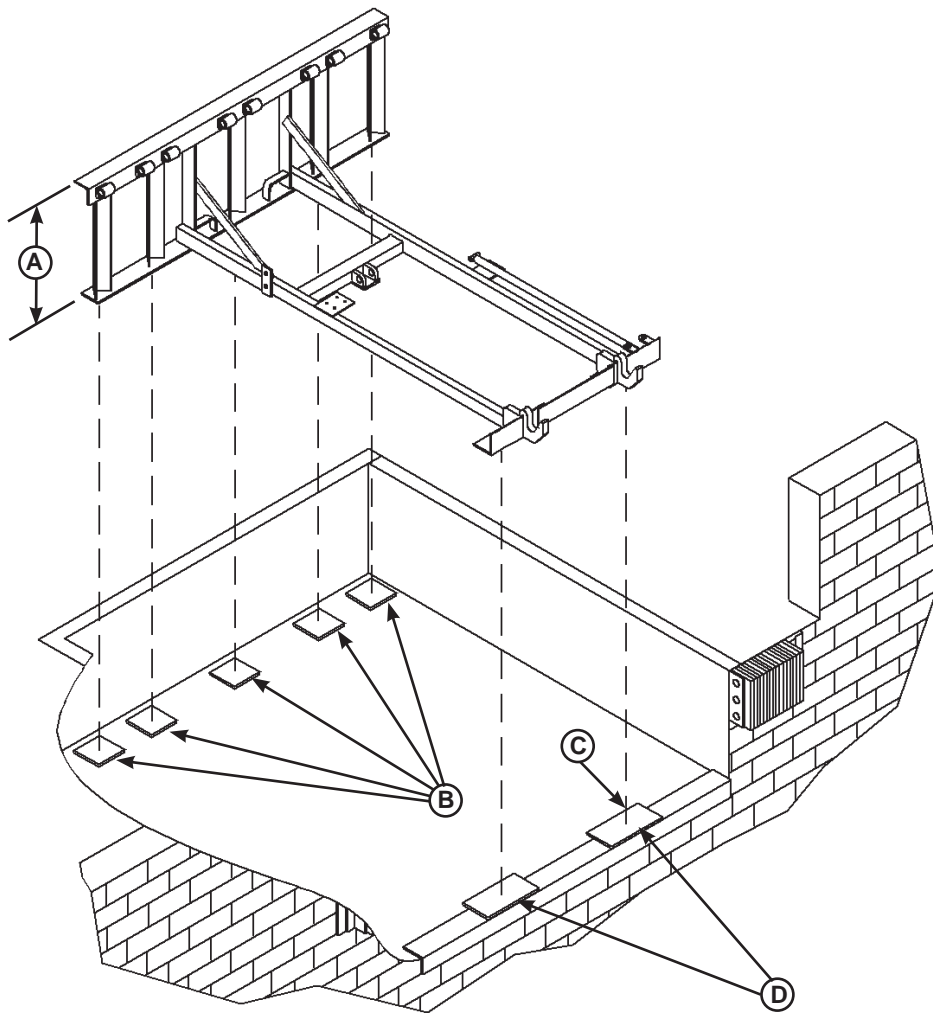

See page 16 for Hoist cylinder shimming

- A— Distance (Leveler Frame Height)
- B— Shim Locations (Under Rear Vertical Supports)
- C— Shim Location (Under Maintenance Prop)
*Same as (D)
- D— Shim Locations (Under Lip Keepers)
- E— Dock Floor
- F— Rear Pit Curb Angle
- G— String
- H— Rear Hinge Frame Angle
- J— Distance (Dock Floor-to-Pit Floor)
- K— Distance (Top of Shim Stack-to-Dock Floor)
- L— Shim Stack
- M— Dock Leveler Frame
- N— Pyramid (Preferred)
- P— Stepped (Acceptable)
- Q— Offset (Not Acceptable)
- R— Straight (Not Acceptable)

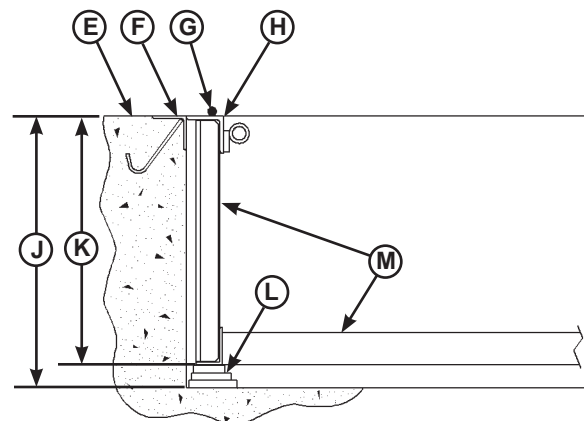

NOTE: Poweramp dock leveler's are designed with a nominal 1/2 in. (12.7 mm) shimming distance to allow for pit inconsistencies.

1. Determine height of shim stack (L) for each shim location (B) by performing the following:
 - a. Measure leveler frame height distance (A).
 - b. Measure dock floor-to-pit floor distance (J) at each shim location (B). Write down the dimensions obtained at each location.
 - c. Subtract distance (A) from distance (J) to obtain the shim height. Repeat for each shim location.

IMPORTANT

The minimum size of the shim that contacts the leveler frame (i.e., the top shim of each shim stack) must be at least 4-1/2 x 4-1/2 in. (114.3 x 114.3 mm) to support the full width of the frame rail and to provide a shelf for a fillet weld.

Use the thickest shim stock possible for stability and weld penetration purposes. DO NOT use multiple layers of 1/8 in. (3.18 mm) or thinner shim stock.

2. Using the results obtained in step 1, create the individual shim stacks on the pit floor at locations (B). Build each shim stack (L) using the pyramid method (N) (preferred) or stepped method (P) with the top shim having a minimum size of 4-1/2 x 4-1/2 in. (114.3 x 114.3 mm) and each successive lower shim being larger so the shims can be welded together using a fillet weld. DO NOT use offset method (Q) or straight method (R).

NOTE: To assist in obtaining an accurate measurement of distance (K), use a string (G) pulled tight across the pit opening, directly over the shim locations.

3. Verify that each shim stack is at the correct height by measuring distance (K) [top of shim stack (L) to dock floor]. Distance (K) must equal the dock leveler height (A).

4. For all EH models, put a 1/4 in. (6.6 mm) thick shim at locations (C and D) .

NOTE: A 1/4 in. (6.6 mm) thick shim at locations (C and D) is used only as a starting point. The final shim stack height will be determined after dock leveler is lowered into the pit.



WARNING

The dock leveler is heavy. Use chains and a lifting device with the appropriate lifting capacity and reach. Failure to do so may result in damage to dock leveler and/or serious personal injury or death.

5. Using an appropriate lifting device connected to the lifting brackets, lower dock leveler into the pit so rear hinge frame angle (H) is tight against rear pit curb angle (F) across full width of the leveler frame.
6. Allow rear of dock leveler to rest on the rear shims while keeping the front of the dock leveler level with the dock floor.
7. For all EH models, add shims at front shim locations (C and D) so front of dock leveler will stay level with dock floor when leveler is resting fully on shims.

INSTALLATION

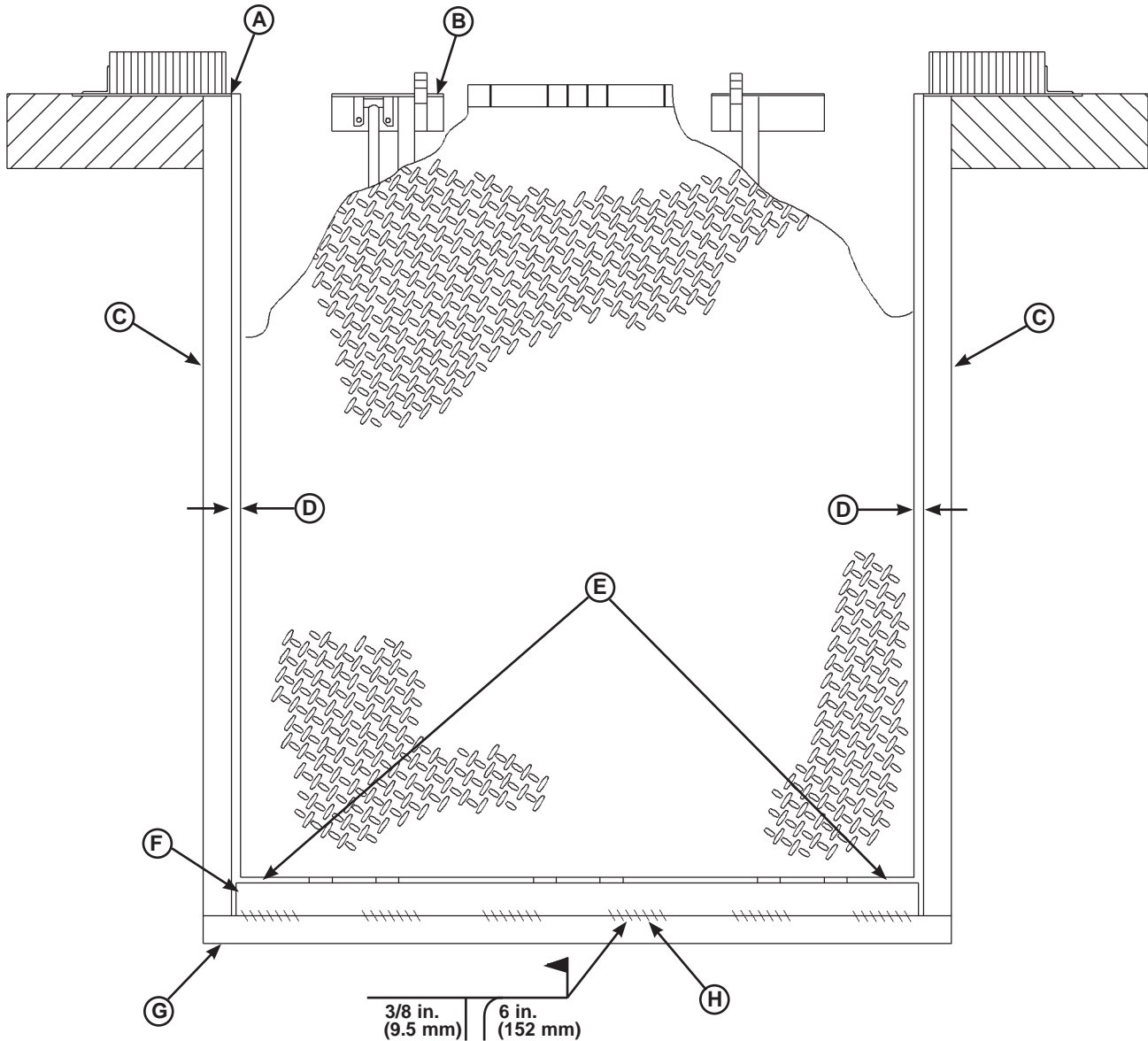

- | | | | |
|-----------------------|----------------------------------|---------------------------|---|
| A— Front of Dock Pit | C— Side Pit Curb Angle | E— Pry Locations | G— Rear Pit Curb Angle |
| B— Dock Leveler Frame | D— Gap [3/4 in. (19 mm) Minimum] | F— Rear Hinge Frame Angle | H— Flare Bevel Weld, Typical (To Fit Spacing) |

8. With rear hinge frame angle (F) tight against rear pit curb angle (G), perform/check the following:
 - Pry between the platform and rear hinge frame angle at locations (E) to make sure rear edge of platform is parallel to the rear hinge frame angle (F).
 - Gap (D) must exist equally along both sides of leveler so weather seal (if equipped) will not bind during dock leveler operation.
9. If gap (D) cannot be obtained equally at both sides of leveler, grind or add material at the rear edge of rear hinge frame angle (F) as needed.
10. Allow the dock leveler to rest fully on the shim stacks. Check that a smooth and level transition exists between the dock floor and the dock leveler platform. Add or remove shims as necessary until a smooth transition is obtained.
11. If leveler cannot be squared and/or made level as instructed in steps 8 — 10, contact Poweramp Technical Services.



WARNING

DO NOT grind or weld if hydraulic fluid or other flammable liquid is present on the surface to be ground or welded.

DO NOT grind or weld if uncontained hydraulic fluid or other flammable liquid is present. Stray sparks can ignite spills or leaks near the work area. Always clean up the oil leaks and spills before proceeding with grinding or welding.

Always keep a fire extinguisher of the proper type nearby when grinding or welding.

Failure to follow these instructions may result in serious personal injury or death.

IMPORTANT

DO NOT connect the dock leveler electrical wiring and ground connections until all welding has been completed.

DO NOT ground welding equipment to any hydraulic or electrical components of the dock leveler. Always ground welding equipment to the dock leveler frame, NEVER to the platform.

Failure to follow these instructions may damage the motor, hoist cylinder, wiring, and/or control panel.

NOTE: The illustration on the previous page shows a typical weld pattern. The weld pattern will vary slightly depending on size of dock leveler.

IMPORTANT

DO NOT weld continuously along the full length of the rear hinge frame angle. This can put unnecessary stress on the leveler components, causing the leveler to malfunction and shorten the life span of the affected components.

11. With the rear hinge frame angle (F) tight against the rear pit curb angle (G), weld the rear hinge frame angle (F) to the rear pit curb angle (G) using a 3/8 in. (9.5 mm) flare bevel skip weld — each weld being 6 in. (152 mm) long.

Start at each end with a 6 in. (152 mm) long weld. Space all the other welds out evenly leaving approximately 6 in. (152 mm) space between each weld.

12. Weld front of dock leveler frame (B) to shims located under the keepers, then weld the shims to the front pit curb steel.
13. With leveler welded into place, remove the shipping bands from around lip and leveler frame.



WARNING

If the platform is raised using an external lifting device or the hydraulic system is opened to atmosphere, air will enter into the hydraulic system.

Whenever this happens, always cycle the leveler at least 4 times using the leveler's own hydraulic power system before allowing the leveler to be put into service. This is to make sure all air is purged from the hydraulic cylinders. Failure to do this may result in serious personal injury or death.

INSTALLATION

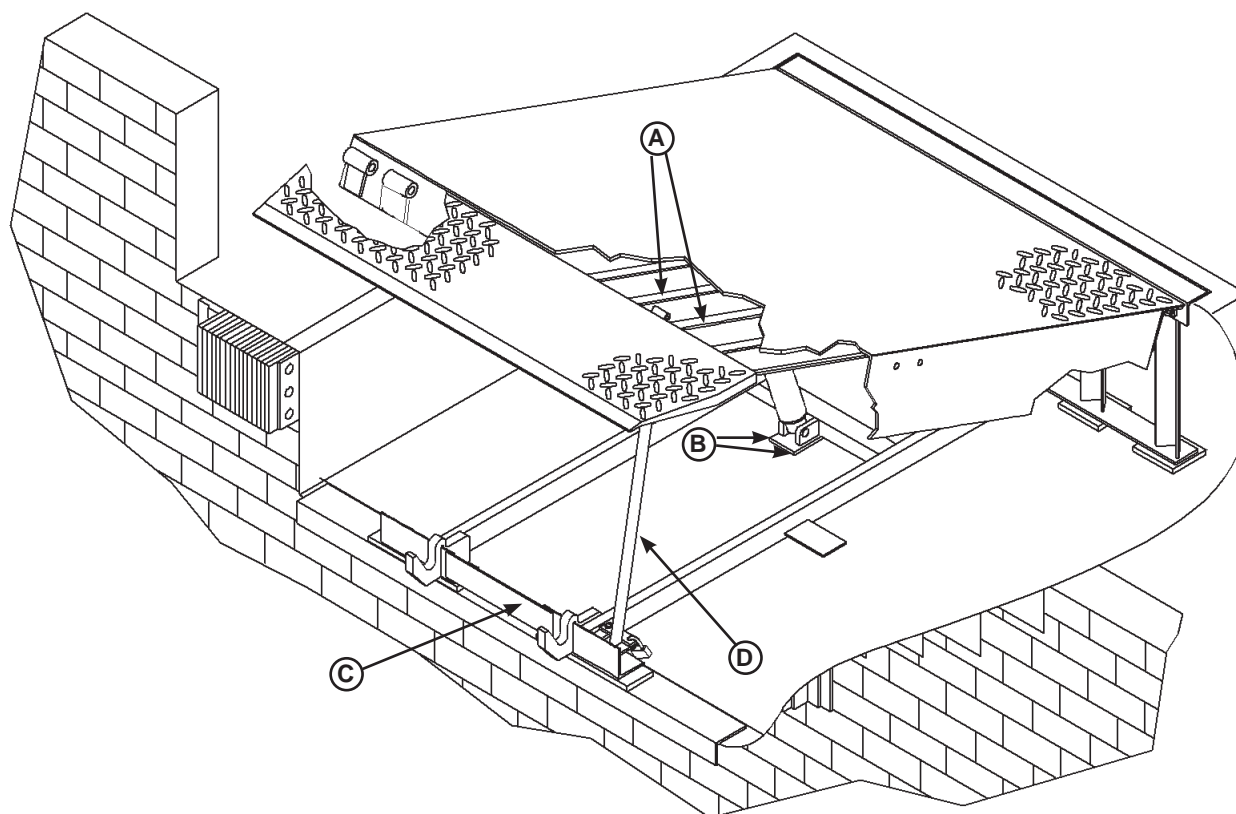

A— Platform Joists
B— Shim Locations (Under Platform Cylinder Trunnions)
C— Removable “Clean Sweep” Frame Section

C—Clean Sweep Removable Frame Section
D— Maintenance Prop

14. Using an external lifting device (i.e., crane or fork truck) attached to the platform lifting brackets, slowly raise the platform. Check for binding as platform is being raised.
15. If binding occurs, lower the platform. Reposition leveler and/or add or remove shims as necessary. Slowly raise platform again. If platform still binds, contact Poweramp Technical Services for further instructions.
16. All EH models:
 - a. Install shims under maintenance prop (D) where prop attaches to leveler frame. Make sure prop is solidly shimmed.
 - b. Using the appropriate lifting device, attached to the platform lifting lugs, slowly raise the dock to the fully open position.

CAUTION

Two people are required to engage the maintenance prop: one person to operate the lifting device, the other person to engage the maintenance prop.

WARNING

DO NOT use the maintenance prop to support the raised platform until the maintenance prop has been properly shimmed and welded. The shims must be welded to each other, the leveler frame, and to the front pit curb steel. Failure to do this may result in serious personal injury or death.

- c. Raise maintenance prop (D) to the service (upright) position and lock prop in this position using an OSHA approved locking device.

- d. Proceed to step 18.



WARNING

Make sure the platform is properly supported in the raised position before entering the pit to finish weld the shims. Failure to do this may result in serious personal injury or death.

18. All model leveler's: Install shims at locations (B) using the pyramid or stepped shimming method. Both platform cylinder trunnions must be solidly shimmed the entire length of the trunnion. Make sure the trunnions are level from side-to-side as well as from front-to-back.
19. Finish weld all frame and cylinder trunnion shims using a fillet weld.
 - Adjust shim height as needed. Remember, each upright rear frame member must be solidly shimmed between the floor of the leveler pit and the bottom of the frame section.
 - Weld all shims within each shim stack to each other, then weld the shim stack to the leveler frame.
 - Weld the front leveler frame shim stacks to the front pit curb steel.

20. When all welding has been completed, paint all the welds and shims.

NOTE: EH models are shipped with a front frame section (C) installed. This temporary frame holds the leveler frame at the correct dimensions until the leveler is permanently anchored into place. Only then should it be removed.

There are four cap screws and nuts that fasten the T-frame to the rest of the leveler frame. Tack welds may also be used.

21. For all EH models, remove the Clean Sweep frame section (C) by grinding the tack welds that hold it in place during transport. Paint after.

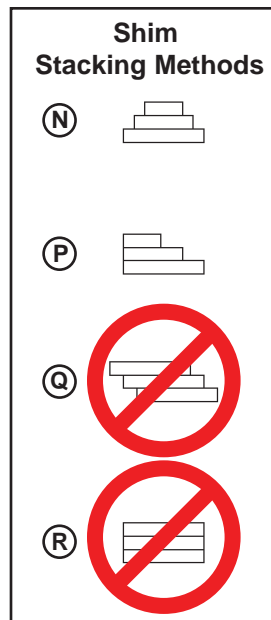

* For left/right orientation of dock leveler, see inside back cover of this manual.

INSTALLATION

Install Control Panel and Wiring

⚠ DANGER



**Arc Flash and Shock Hazard
PPE (Personal Protection Equipment) Required**

De-energize equipment before working on or inside. Do not open cover without appropriate PPE. Refer to NFPA 70E for PPE requirements. This panel may contain more than one power source.

**Hazardous Voltage
Will Cause Severe
Injury or Death**

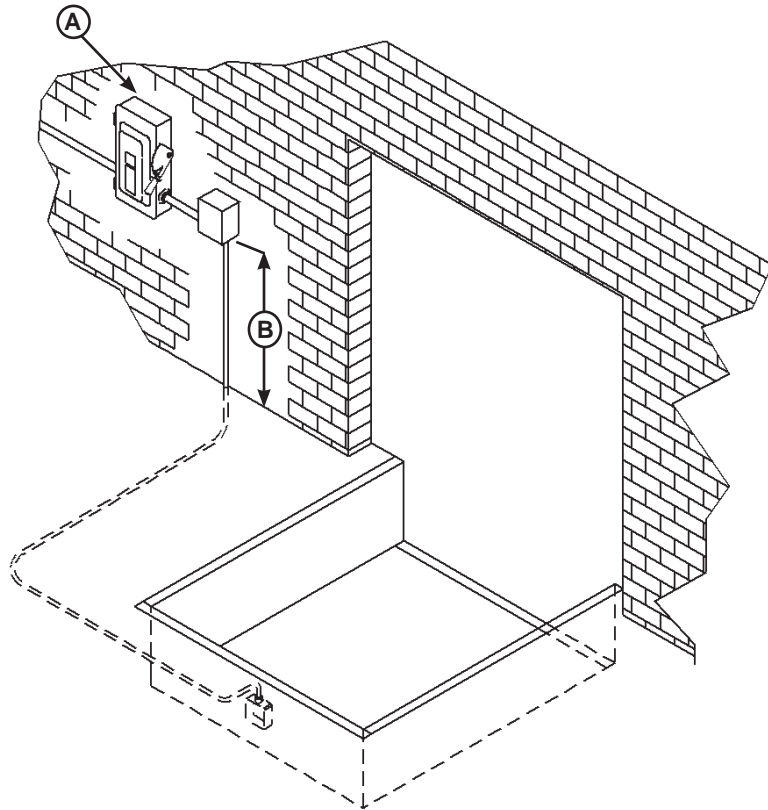

⚠ WARNING

DO NOT make any final electrical connections until all welding has been completed. Failure to do this may result in serious personal injury or death.

⚠ WARNING

The electrical power must be OFF prior to electrical installation. For maximum protection, use an OSHA approved locking device to lock out all power sources. Only the person installing the equipment should have the key to unlock the power source.

Failure to follow these instructions may result in serious personal injury or death.

⚠ CAUTION

All electrical work — including the installation of the disconnect panel, control panel, and final connections to the pit junction box — must be performed by a certified electrician and conform to all local and applicable national codes.

A— Disconnect Panel (provided by others)
B— Distance, 48 in. (14 630 mm)

1. Mount the push button control panel (B) so bottom of control panel-to-dock floor distance (C) is 48 in. (1219.2 mm).
2. Install electrical disconnect panel (A) if not already installed.
3. Install and connect the control wiring.
4. Connect the dock leveler power cable to the field wires in the pit junction box. Refer to the electrical drawings supplied with the dock leveler.
5. After all electrical connections in the pit have been made, disengage the maintenance prop and lower the platform using the external lifting device connected to the platform lifting brackets.

Put New Dock Leveler Into Service

1. Disconnect the external lifting device and chains from the lifting brackets.
2. Check that the leveler is flush with the dock floor and that the platform lip contacts both lip keepers evenly.

If an excessive transition exists between the dock floor and leveler and/or lip does not contact both lip keepers evenly, contact Poweramp Technical Services for further instructions.

3. Install the dock bumpers as required.
4. Turn the main electrical power ON.



WARNING

Always stand clear of platform lip when working in front of the dock leveler. Serious personal injury or death may result.

5. Raise the leveler platform fully by pushing and holding the RAISE button .

NOTE: The platform of a properly operating dock leveler will automatically stop rising when it reaches its maximum full raised height, at which point, the lip extends. When the lip is fully extended, the powerpack will go in to by-pass. (If the lip does not extend or extend fully, see Platform Rises to Full Height, But Lip Does Not Fully Extend in the Troubleshooting section.)

6. Release the RAISE button to lower the platform. As long as there is no vehicle present at the dock, the platform will lower to the full below-dock position as the lip folds.

NOTE: If a Transport Vehicle is present, the platform will lower until the lip rests on the Transport Vehicles bed. (See Operating Instructions in Operation section.)

7. When the platform lowers to the full below-dock position, push and hold the RAISE button until the platform rises just enough to clear the lip keepers, then release the RAISE button to allow the platform to lower to the cross-traffic (stored) position (lip engages lip keepers).

NOTE: For dock leveler's equipped with the Auto Return To Dock (ARTD), the platform will automatically return to the cross-traffic position if the ARTD is enabled. When the platform is at the full below-dock position, there is a six-second delay before the platform will automatically rise to the cross-traffic position.

8. Perform steps 5 – 7 at least four times to purge any air that may be in the hydraulic system and to ensure proper operation.



CAUTION

Unless the dock leveler is equipped with a tethered remote, two people are required to engage the maintenance prop: one person to operate the unit, the other person to engage the maintenance prop.

9. Raise the platform fully. Hold the platform at this position using the RAISE button and move the maintenance prop to the service (upright) position. Release the RAISE button to allow the platform to lower until it is resting on the maintenance prop.
10. Secure the maintenance prop with the maintenance prop lock-out.
10. With the maintenance prop supporting the platform, remove the lifting brackets and Clean Sweep frame section in between lip keepers, if you haven't already done so.
10. Release the maintenance prop by unlocking the lock-out.
12. Push and hold the RAISE button until the maintenance prop drops to its stored position. Release the RAISE button and allow the platform to lower fully.
13. Perform step 7 if not equipped with ARTD.

OPERATION

Operating Instructions

DANGER

Stay clear of dock leveler when transport vehicle is entering or leaving dock area.

DO NOT move or use the dock leveler if anyone is under or in front of leveler.

Keep hands and feet clear of pinch points. Avoid putting any part of your body near moving parts.

Failure to follow these instructions may result in severe personal injury or death.

WARNING

Only trained personnel should operate the dock leveler.

DO NOT use a broken or damaged dock leveler. Make sure proper service and maintenance procedures have been performed on leveler before using.

Transport vehicles wheels must be chocked unless the vehicle restraint is used. Never remove the wheel chocks until loading/unloading is finished and transport driver has been given permission to leave.

Make sure platform lip rests on the transport vehicles bed with at least 4 in. (102 mm) of overlap.

Maintain a safe distance from side edges of leveler during the loading/unloading process.

Failure to follow these instructions may result in serious personal injury or death.

WARNING

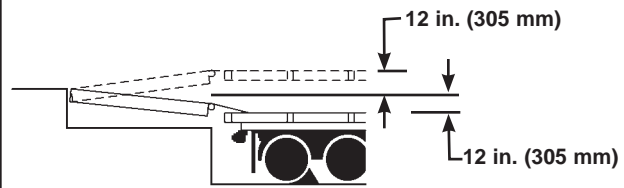

The EH hydraulic dock leveler is designed to compensate for a maximum ± 12 in.* (305 mm) of height difference between the loading dock and the transport vehicles bed. DO NOT use the dock leveler if the transport vehicles bed is more than 12 in. (305 mm) higher or lower than the dock floor.

*Service height may vary with design specifications

DO NOT overload the dock leveler.

DO NOT operate any equipment while under the influence of alcohol or drugs.

DO NOT leave equipment or material unattended on the dock leveler.

Failure to follow these instructions may result in personal injury and/or damage to equipment.

The dock leveler operating instructions are divided into the two methods of loading and unloading:

- **For ramp loading and unloading, see Ramp Loading/Unloading Instructions on page 21.**
- **For end loading and unloading, see End Loading/Unloading Instructions on page 22.**

Operating Instructions—Continued

Ramp Loading/Unloading Instructions

NOTE: If end unloading is required, see End Loading/Unloading Instructions on page 24.

For ramp loading or unloading, the EH dock leveler can be operated by using the RAISE button on the control panel.

1. Check to make sure the transport vehicle is positioned squarely against dock bumpers.
2. Instruct driver to remain at the dock until the loading or unloading process has been completed.
3. Chock the transport vehicles wheels or use the truck restraint if available.

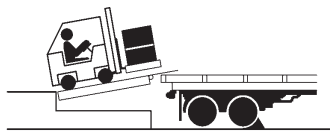
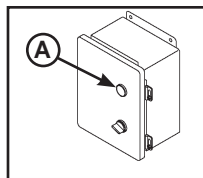

A—RAISE Button

4. Extend the platform lip onto transport vehicle as follows:
 - a. Raise the platform by pushing and holding RAISE button .
 - b. Hold the RAISE button until the lip is fully extended, then release the RAISE button. The platform will lower until the lip is resting on the Transport Vehicle bed.
 - c. Make sure that the lip is fully extended and supported on the transport vehicle along the entire width of the platform with at least 4 in. (102 mm) of lip contacting the transport vehicle bed.

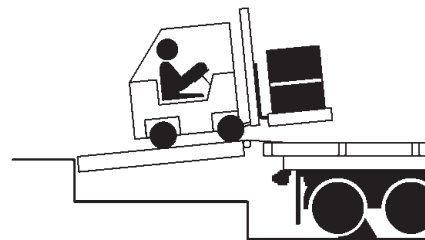

5. Proceed with loading or unloading the transport vehicle.
6. If end loading is necessary, see End Loading/Unloading Instructions on page 20.

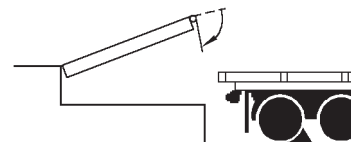
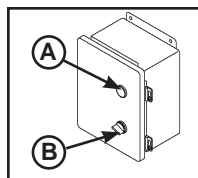

A—RAISE Button

B—ARTD Switch

7. When loading or unloading is finished, raise the platform by pushing and holding RAISE button (A) .

Hold the RAISE button until the lip folds enough to clear the transport vehicles bed, then release the RAISE button. The lip will fold and the platform will return to the cross-traffic position.
8. Remove chocks from transport vehicle wheels or release the truck restraint if used.
9. Indicate to driver that the transport vehicle may leave the dock.

OPERATION

Operating Instructions—Continued

End Loading/Unloading Instructions

NOTE: If ramp loading is required, see Ramp Loading/Unloading Instructions on page 19.

End loading or unloading can be done with the dock at the cross-traffic position or below-dock position, depending on the height of the Transport Vehicles bed.

1. Check to make sure transport vehicle is positioned squarely against dock bumpers.
2. Instruct driver to remain at the dock until the loading or unloading process has been completed.
3. Chock the transport vehicles wheels or use the vehicle restraint if available.

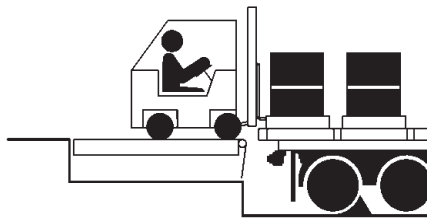

End Loading/Unloading — Platform at Cross-Traffic Position.

4. If transport vehicles bed is at or above dock floor level, leave leveler at the cross-traffic position and proceed with loading or unloading.

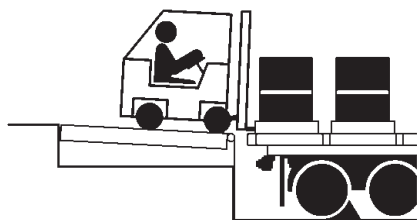

End Loading/Unloading — Platform at Below-Dock Position.

5. If transport vehicles bed is below the dock floor level, and the dock is equipped with the optional lip-out button, perform steps 6–12.

CAUTION

Whenever end loading or unloading with the platform in the below-dock position, make sure the ARTD switch is in the OFF position. DO NOT turn the ARTD switch to the ON position until end loading or unloading is finished.

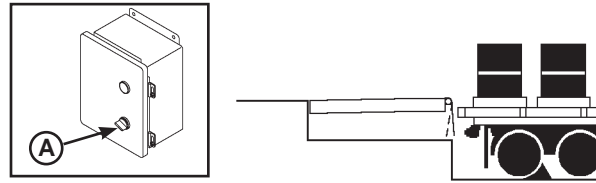

A—ARTD Switch

6. Turn the ARTD switch (A) on the control panel to the OFF position, if equipped.
7. Push the Raise button (B) to the platform just enough to clear the lip keepers.
8. When the platform lip clears the lip keepers, push the Lip-Out button (C) just long enough to clear the lip keepers. Release Lip-Out button. The platform will drift down to the full below-dock position.
9. Proceed with loading or unloading.

NOTE: When end unloading is finished and access to the rest of the Transport Vehicles is still required, the platform lip will need to be extended. See Ramp Loading/Unloading Instructions on page 19 for further instructions.

10. When the loading or unloading is finished, return the dock leveler platform to the cross-traffic (stored) position by performing one of the following:

- Turn the ARTD switch (A) to the ON position, if equipped. After approximately six seconds, the platform will automatically rise to the cross-traffic position.

OR

- Push the Raise button (B) until the lip clears the lip keepers. Release Raise button, leveler will return to the stored or cross traffic position.
11. Remove chocks from Transport Vehicles wheels or release the restraint if used.
 12. Indicate to the driver that the Transport Vehicle may leave the dock.

Service Dock Leveler Safely

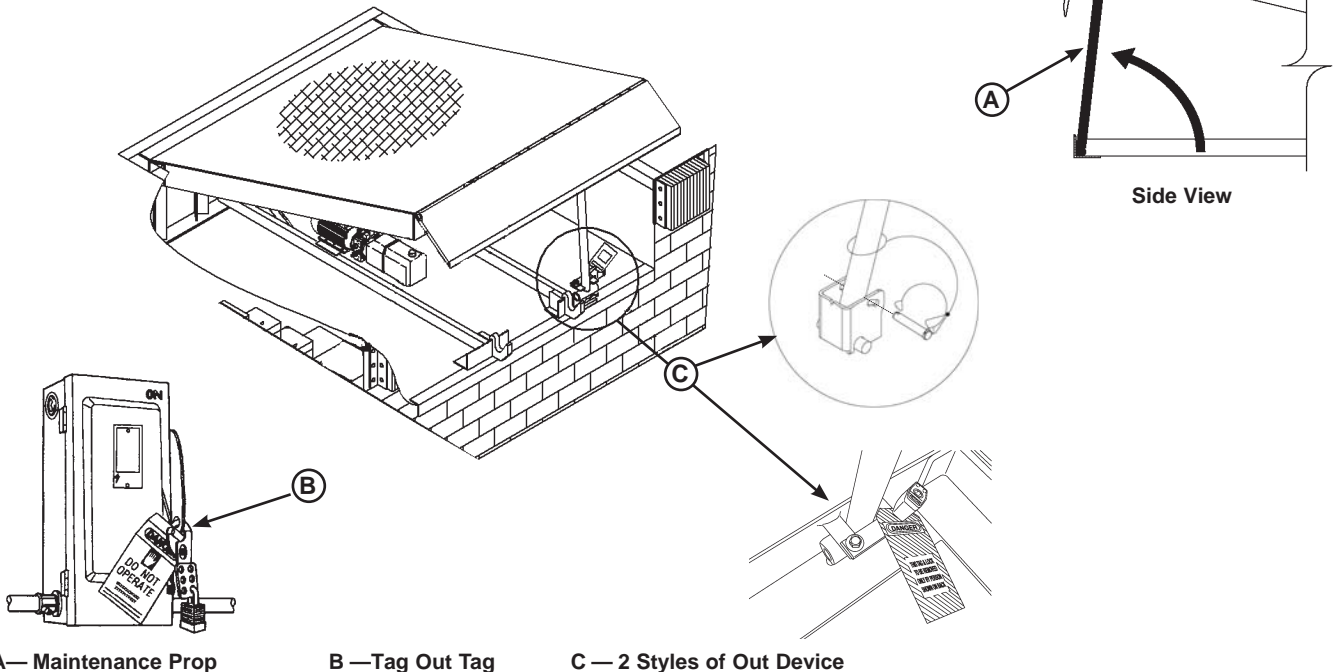

A— Maintenance Prop

B —Tag Out Tag

C — 2 Styles of Out Device

! WARNING

When service under the dock leveler is required, always lock all electrical disconnects in the OFF position after raising the platform and engaging the maintenance prop. Failure to do this may result in serious personal injury or death.

! WARNING

Always post safety warnings and barricade the work area at dock level and ground level to prevent unauthorized use of the dock leveler before maintenance is complete. Failure to do this may result in serious personal injury or death.

! WARNING

Always stand clear of the dock leveler lip when working in front of the dock leveler.

The maintenance prop MUST be in the service position when working under the dock leveler. For maximum protection, use an OSHA approved locking device to lock the maintenance prop in the service position. Only the person servicing the equipment should have the key to unlock the maintenance prop.

Unless the dock leveler is equipped with a tethered remote, two people are required to engage the maintenance prop: one person to operate the unit, the other person to engage the maintenance prop.

Failure to follow these instructions may result in serious personal injury or death.

Whenever maintenance is to be performed under the dock leveler platform, support the platform with maintenance prop (E). Position the maintenance prop behind front header plate while staying clear of the lip. The lip will fold down after the platform has rested on the maintenance prop. Lock the maintenance prop in the service (upright) position using an OSHA approved lockout device* (C) and Tag-Out device* (D).

Whenever servicing the dock leveler, lock the electrical power disconnect in the OFF position. Use only an OSHA approved lockout device* (B) and Tag-Out device (A).

Only the person servicing the equipment should have the capability to remove the lockout devices. The Tag-Out devices* must inform that repairs are in process and clearly state who is responsible for the lockout condition.

* Refer to OSHA regulation 1910.147.

* Refer to OSHA regulation 1910.146.

MAINTENANCE

Periodic Maintenance

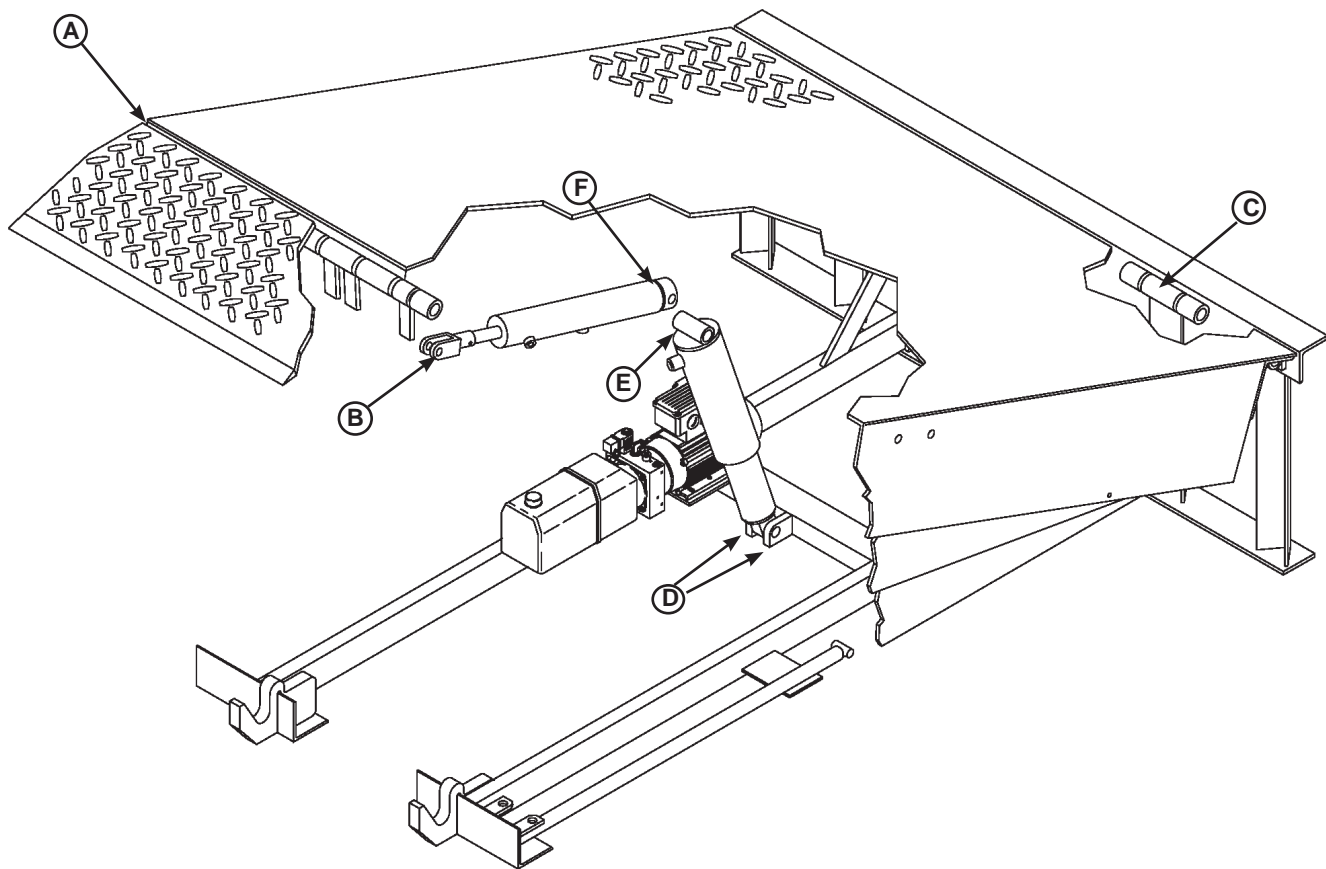

A— Lip Hinge Area

B— Lip Lifter and Lip Cylinder Pin

C— Platform Hinge Area

D— Platform Cylinder Trunnion

E— Platform Cylinder-to-Platform Pin

F— Lip Cylinder-to-Platform Frame Pin



WARNING

Before performing any maintenance under the dock leveler, lock the electrical power source in OFF position and lock the maintenance prop in the service position using an approved locking device. (See Service Dock Leveler Safely in this section.)

Failure to follow these instructions may result in serious personal injury or death.

To ensure normal operation of the dock leveler, use only aircraft hydraulic fluid designed to meet or exceed military specification MIL-L-5606. It is recommended that the following hydraulic fluids be used:

- ULTRA-VIS-HVI-15
- Aero Shell Fluid 4 or Fluid 41
- Mobile Aero HFA Mil-HS606A or Aero HF
- Texaco Aircraft Hydraulic Oil 15 or 5606
- Exxon Univis J13

IMPORTANT

Use of fluids that do not have equivalent specifications to those in the following list will result in abnormal operation of the dock leveler and voiding of warranty.

These fluid brands can be mixed together. Mixing with fluids that do not meet or exceed MIL-H-5606-G may damage the equipment and WILL void warranty. Use of hydraulic fluids with equivalent specifications to those listed here are acceptable.

Regular maintenance must be performed on a weekly and quarterly schedule.

Weekly Maintenance

- Operate the dock leveler through the complete operating cycle to maintain lubrication.

NOTE: To thoroughly inspect the platform hinge area, put the platform in the full below-dock position.

- Inspect the platform hinge and the lip hinge areas. The hinge areas must be kept free of dirt and debris. Build-up of foreign material in the hinge areas will cause abnormal operation.

Quarterly Maintenance

IMPORTANT

Failure to properly lubricate the dock leveler will cause abnormal operation of the leveler.

- Lubricate the following areas with light weight machine oil:
 - (A)— Lip hinge area unless equipped with grease fittings (apply oil to the top of the entire length of lip hinge when platform is at the full below-dock position and lip is folded)
 - (C)— Platform hinge area (apply oil to top of all platform hinges when platform is at the full below-dock position)
 - (E)— Platform cylinder-to-platform frame pin
 - (F)— Lip cylinder-to-platform frame pin
 - (G)— Lip lifter and lift cylinder pin
- Lubricate the following areas with white lithium grease:
 - (B)— Valve lever pivot and top of logic block spool valve.
 - (D)— All platform cylinder trunnions

NOTE: Apply grease to lip hinge grease fittings if equipped.

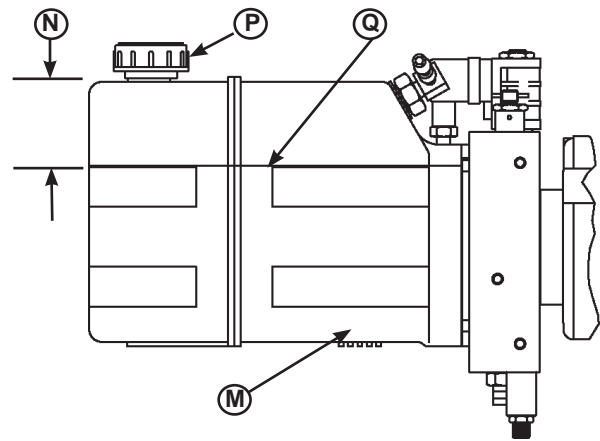

M— Reservoir
N— 2 in. (51 mm)
From Top of Reservoir

P— Breather Cap
Q— Fluid Level

IMPORTANT

A low fluid level or the use of hydraulic fluids not equivalent to the fluid types recommended, will cause abnormal operation of the leveler and WILL void warranty.

WARNING

Before performing any maintenance under the dock leveler, lock the electrical power source in OFF position and lock the maintenance prop in the service position using an approved locking device. (See Service Dock Leveler Safely in this section.)

Failure to follow these instructions may result in serious personal injury or death.

- Check reservoir fluid level (Q):
 1. Put the dock leveler platform at the full above-dock position.
 2. Turn OFF all electrical power to the leveler.
 4. Remove breather cap (P).
 5. Measure fluid level. The fluid level should be approximately 2 in. (50.8 mm) (N) from top of reservoir (M) with platform at the below-dock position.
 6. Add hydraulic fluid if necessary. Use only recommended fluid.
 7. Install breather cap and inspection plate.
 8. Turn ON electrical power to the leveler.
 9. Return the platform to the cross-traffic position.

ADJUSTMENTS

Valve Adjustment Procedure

WARNING

When service under the dock leveler is required, always lock all electrical disconnects in the OFF position after raising the platform and engaging the maintenance prop. Failure to do this may result in serious personal injury or death.

WARNING

Always post safety warnings and barricade the work area at dock level and ground level to prevent unauthorized use of the dock leveler before maintenance is complete. Failure to do this may result in serious personal injury or death.

WARNING

Always stand clear of the dock leveler lip when working in front of the dock leveler.

The maintenance prop **MUST** be in the service position when working under the dock leveler. For maximum protection, use an OSHA approved locking device to lock the maintenance prop in the service position. Only the person servicing the equipment should have the key to unlock the maintenance prop.

Unless the dock leveler is equipped with a tethered remote, two people are required to engage the maintenance prop: one person to operate the unit, the other person to engage the maintenance prop.

Failure to follow these instructions may result in serious personal injury or death.

NOTE: All Poweramp EH leveler's are factory tested and should not require additional adjustments in the field. Consult the factory if minor adjustments do not result in proper operation.

Whenever valve adjustments are made, note the number of turns made to allow an undesirable adjustment result to be reversed.

CAUTION: Do not adjust relief valve (RV1) this valve is preset has a security lock to prevent adjustment.

Valve Adjustment Procedure Hoke / KTI

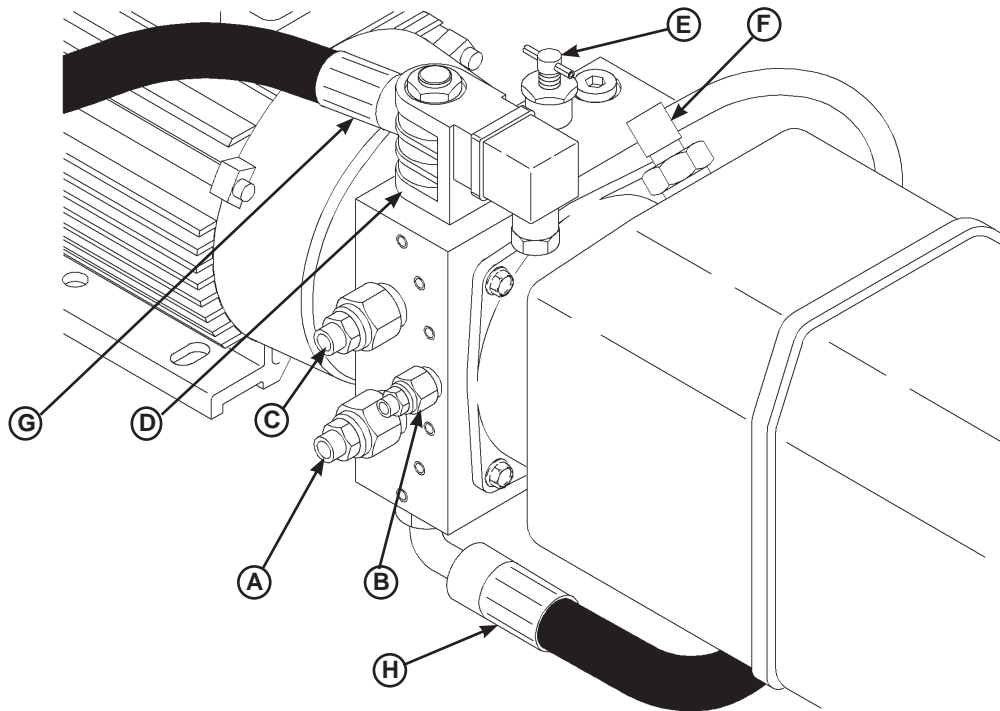

A—S2 Valve
B— RV1 Valve

C—S1 Valve
D— 2W NO Spool Valve/Coil

E— NV1 Valve
F— Breather Tube/Fitting

G—To Hoist Cylinder
H—To Lip Cylinder

*Note: Not pictured on the bottom of the valve body are the RV2 and PO Check Valves

S1 Sequence Valve 1

Controls the Platform Cylinder. When the leveler has reached the top of its travel allow the leveler to float down. Fluid should flow through the NV1 valve. If you hear the motor spinning backwards, or Leveler and/or Lip may dropping prematurely adjust S1 clockwise in small increments, testing each time, until the motor is not spinning backwards or Leveler and/or Lip may drop correctly.

S2 Sequence Valve 2

Controls the Lip Cylinder. This valve should be set to allow a smooth, quiet shift. Turning S2 counter-clockwise causes the lip to extend.

If the lip does not extend turn S2 counter-clockwise out small increments until lip begins to extend. Once the lip is extended allow the powerpack to operate in pressure relief, then allow the leveler to return below dock.

Raise the leveler and continue to adjust the S2 valve to allow a smooth, quiet shift. When adjusted properly, the lip should stay extended until below dock. Lip extension cycle should not take more than a few seconds.

NV1 Need Valve 1

Controls the Down speed of the ramp cylinder. Increase Down speed by turning NV1 counter-clockwise, Decrease Down speed by turning NV1 clockwise.

RV2 Relief Valve 2

Allows the lip to collapse below dock, protects the lip if it is backed in to. Set the RV2 valve by backing out adjustment screw as far as it goes.

Return leveler to keepers and begin to raise it. Halfway up, allow the leveler to return for a second, then raise leveler. The lip should not extend. If lip extends, turn S2 valve clockwise 1/4 turn and repeat until lip does not extend.

PO CHK Pilot Operated Check Valve

Keeps Lip from collapsing until it is below dock. This valve is not adjustable. If lip malfunctions, cleaning or replacement may be required.

RV1 Main Relief Valve

Sets system pressure

2W 2 Way Normally Open Spool Valve - Optional

If present, can extend lip with Lip Out option or it can be used as an emergency stop if power is not running.

ADJUSTMENTS

Valve Adjustment Procedure Monarch/Bucher

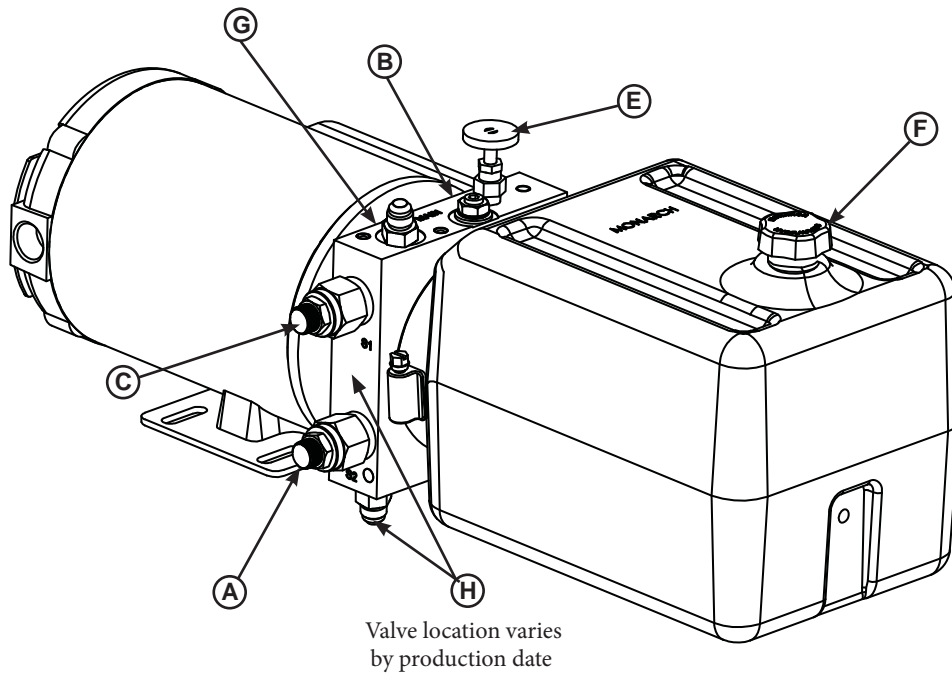

A—S2 Valve
B—RV1 Valve

C—S1 Valve
D— Not Used

E— NV1 Valve
F— Breather Tube/Fitting

G—To Hoist Cylinder
H—To Lip Cylinder

S1 Sequence Valve 1

Controls the Platform Cylinder. When the leveler has reached the top of its travel allow the leveler to float down. Fluid should flow through the NV1 valve. If you hear the motor spinning backwards, or Leveler and/or Lip may dropping prematurely adjust S1 clockwise in small increments, testing each time, until the motor is not spinning backwards or Leveler and/or Lip may drop correctly.

S2 Sequence Valve 2

Controls the Lip Cylinder. This valve should be set to allow a smooth, quiet shift. Turning S2 counter-clockwise causes the lip to extend.

If the lip does not extend turn S2 counter-clockwise out small increments until lip begins to extend. Once the lip is extended allow the powerpack to operate in pressure relief, then allow the leveler to return below dock.

Raise the leveler and continue to adjust the S2 valve to allow a smooth, quiet shift. When adjusted properly, the lip should stay extended until below dock. Lip extension cycle should not take more than a few seconds.

NV1 Need Valve 1

Controls the Down speed of the ramp cylinder. Increase Down speed by turning NV1 counter-clockwise, Decrease Down speed by turning NV1 clockwise.

PO CHK Pilot Operated Check Valve

Keeps Lip from collapsing until it is below dock. This valve is not adjustable. If lip malfunctions, cleaning or replacement may be required.

RV1 Main Relief Valve

Sets system pressure

This page intentionally left blank

ADJUSTMENTS

Adjust Auto Return To Dock (ARTD)

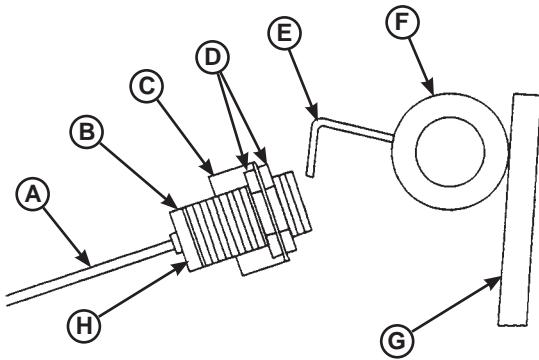

- | | |
|---------------------|--------------------|
| A— Cable | E— Target |
| B— Proximity Switch | F— Lip Hinge Tube |
| C— Bracket | G— Platform Lip |
| D— Lock Nuts | H— Indicator Light |

EH leveler's are equipped with the optional Auto Return To Dock (ARTD) if leveler not interlocked with a truck restraint.

The ARTD allows the platform to automatically return to the cross-traffic (stored) position after the truck departs. The ARTD uses a proximity switch (B) located under the platform and a piece of angled steel called the target (E) that is attached to the lip hinge tube (F).

The proximity switch provides a six-second delay after the platform has lowered to the full below-dock position, after which, the platform will return to the cross-traffic position. The switch also contains an indicator light (H) that can be used for diagnosing and adjusting the switch.

NOTE: Some proximity switches have an indicator light at the back of the housing and some have the light at the side of the housing.

Adjust the ARTD as Follows:

WARNING

When service under the dock leveler is required, always lock all electrical disconnects in the OFF position after raising the platform and engaging the maintenance prop. Failure to do this may result in serious personal injury or death.

WARNING

Always post safety warnings and barricade the work area at dock level and ground level to prevent unauthorized use of the dock leveler before maintenance is complete. Failure to do this may result in serious personal injury or death.

WARNING

Always stand clear of the dock leveler lip when working in front of the dock leveler.

The maintenance prop **MUST** be in the service position when working under the dock leveler. For maximum protection, use an OSHA approved locking device to lock the maintenance prop in the service position. Only the person servicing the equipment should have the key to unlock the maintenance prop.

Unless the dock leveler is equipped with a tethered remote, two people are required to engage the maintenance prop: one person to operate the unit, the other person to engage the maintenance prop.

Failure to follow these instructions may result in serious personal injury or death.

1. Raise platform fully and engage the maintenance prop in the service position. Allow platform to rest on the prop so the lip will fully fold until it contacts the lip stops.
2. Turn OFF all electrical power to the dock leveler. Attach safety lockout and Tag-Out devices.

IMPORTANT

Anytime proximity switch and target are adjusted, always check for interference between target and switch before operating the leveler. Damage to switch will occur if the target contacts the switch.

The maximum torque for proximity switch lock nuts is 10 N·m (7 lb-ft). Damage to switch will occur if maximum torque is exceeded.

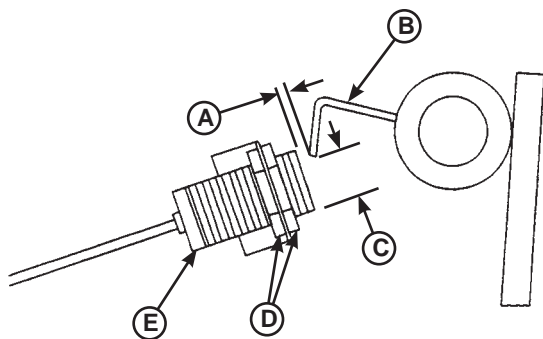

A— 1/4 in. (6.4 mm)
Approximate
B— Target

C— 1 in. (25.4 mm)
Approximate
D— Lock Nuts
E— Proximity Switch

NOTE: Distances (A and C) are typical factory settings. Use these dimensions only as a starting point when adjusting the proximity switch and target, especially if switch and/or target have been replaced.

When dimensions (A and C) are obtained, the proximity switch and target may need finer adjustments to get the ARTD to operate satisfactorily.

- Loosen lock nuts (D). Adjust proximity switch (E) to obtain distance (A). Tighten lock nuts.
- Bend target (B) as needed to obtain distance (C). Recheck distance (A) and readjust if necessary.

NOTE: At least two people may be required to manually move the lip.

- After adjusting proximity switch and target, slowly move the lip up by hand while observing the target and proximity switch. The target **MUST NOT** contact the switch, otherwise, damage to switch will occur. Readjust switch and/or target if necessary, then recheck for interference.

- Turn ON electrical power to the dock leveler.
 - Disengage the maintenance prop.
 - Turn the ARTD switch (on control panel) to the ON position.
 - Raise the platform until the lip is fully extended, then allow the platform to drift to the below-dock position.
- After approximately 6 seconds, the platform must return to the cross-traffic position.
- Adjust the proximity switch and target as necessary. Make small adjustments, then operate the dock leveler to check results. Do this until satisfied with the ARTD operation.

Use the following illustrations to assist in fine tuning and/or diagnosing the ARTD operation.

Cross-Traffic Position

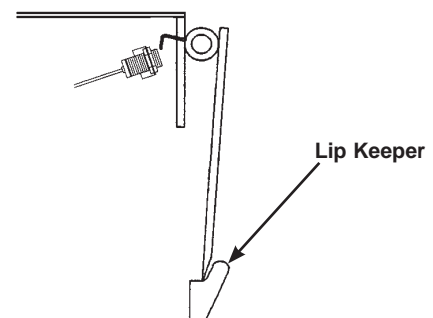

NOTE: The platform lip is fully folded when the platform is at the cross-traffic (stored) position (lip engaged with keepers) or when platform is resting on the maintenance prop.

Whenever the platform lip is at the cross-traffic position, the following conditions will exist for a normally operating ARTD:

- Target not in the sensing area of proximity switch.
- Proximity switch OFF (open) (no signal sent to control panel).
- Proximity switch indicator light is OFF.
- Platform stays at this position unless the operator activates the leveler.

ADJUSTMENTS

Full Below-Dock Position

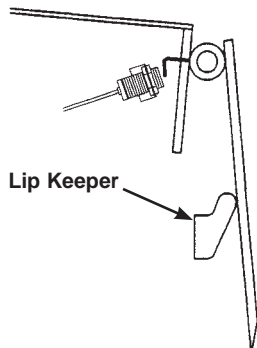

Whenever the platform lip is at the full below-dock position, the following conditions will exist for a normally operating ARTD:

- Proximity switch senses target.
- Proximity switch ON (closed) (signal sent to the control panel).
- Proximity switch indicator light is ON.
- Platform will automatically rise after approximately a six-second delay, then returns to the cross-traffic position.

Lip Fully Extended Position

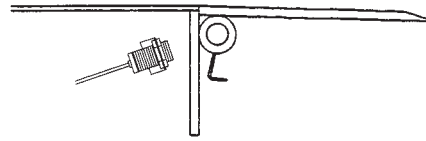

Whenever the platform lip is at the fully extended position, the following conditions will exist for a normally operating ARTD:

- Target not in the sensing area of proximity switch.
- Proximity switch OFF (open) (no signal sent to the control panel).
- Proximity switch indicator light is OFF.
- If the platform lip is resting on the truck bed, the platform will stay at this position unless the operator activates the leveler.

Troubleshooting



WARNING

When service under the dock leveler is required, always lock all electrical disconnects in the OFF position after raising the platform and engaging the maintenance prop. Failure to do this may result in serious personal injury or death.



WARNING

Always post safety warnings and barricade the work area at dock level and ground level to prevent unauthorized use of the dock leveler before maintenance is complete. Failure to do this may result in serious personal injury or death.



WARNING

Always stand clear of the dock leveler lip when working in front of the dock leveler.

The maintenance prop **MUST** be in the service position when working under the dock leveler. For maximum protection, use an OSHA approved locking device to lock the maintenance prop in the service position. Only the person servicing the equipment should have the key to unlock the maintenance prop.

Unless the dock leveler is equipped with a tethered remote, two people are required to engage the maintenance prop: one person to operate the unit, the other person to engage the maintenance prop.

Failure to follow these instructions may result in serious personal injury or death.

Before performing the detailed troubleshooting procedures, check the following items first:

- Check all fuses inside the control panel(s). Replace any blown fuse(s) with a fuse of equal specification.
- Make sure the correct voltages are present at the proper locations inside the control panel(s).

| Symptom | Possible Cause | Solution |
|---|---|--|
| Platform does not rise. Motor does not energize. | Motor overload device tripped or fuse blown. | Reset overload relay (three-phase) or replace fuse(s) (single-phase). Determine cause of overload. <i>NOTE: When replacing fuse(s), the new fuse must have the same specification as the old fuse.</i> |
| | Motor starter (three-phase) or motor relay (single-phase) not energizing. | Check voltage at starter or relay coil. <ul style="list-style-type: none"> • If voltage is present and starter or relay does not energize, replace starter or relay. • If voltage is not present, check all components in series with the starter or relay coil. |

TROUBLESHOOTING

| Symptom | Possible Cause | Solution |
|--|---|---|
| Three-phase units only: Platform does not rise. Motor hums, but does not run. | No voltage is present on one line. | Check for blown fuses at branch circuit disconnect. Replace fuse. Determine cause of blown fuse. |
| | <i>NOTE: A motor that is missing voltage on one line is said to be single-phased.</i> | Check motor starter as follows: 1. Disconnect wires at load side of starter. 2. Energize the starter. 3. Measure line-to-line voltage at line side of starter. 4. Measure line-to-line voltage at load side of starter. 5. Line-side and load-side voltages should be approximately the same. Replace starter if voltage values are considerably different from one another. |
| | | Check all wiring to motor for high resistance or no connection. |
| Three-phase units only: Platform does not rise. Motor runs in reverse | Phase reversed. | Reverse any two legs at the branch circuit disconnect. |
| Single-phase units only: Platform does not rise. Motor energizes, but does not run. | Line voltage too low. | Check wiring to motor for high resistance. Check for loose or corroded connections. Check if gauge of wires to motor are of correct size and specification for load requirement. Replace if necessary. |
| | Defective motor centrifugal switch. | Replace motor. |
| | Defective motor capacitor. | Replace motor. |
| Dock leveler equipped with ARTD: Platform does not automatically return to the cross-traffic position or operates abnormally. | The auto return proximity switch not sensing target correctly. | Adjust proximity switch and target as necessary. See Adjust Auto Return To Dock (ARTD) in the Adjustment section. |
| | Defective proximity switch. | Replace switch. |
| | Broken wire. Loose or corroded wire connections. | Repair or replace wires and connections as necessary. |

TROUBLESHOOTING

| Symptom | Possible Cause | Solution |
|--|--|---|
| Platform does not rise. Pump operates in pressure relief mode. | Heavy object(s) on platform. | Remove object(s) from platform. <i>NOTE: For safety reasons, the dock leveler is designed to lift only the platform's own weight.</i> |
| | Dock leveler binds. | Check for visible obstructions that could cause binding. Remove obstructions. If no obstructions found, call Poweramp Technical Services. See inside back cover for phone number and address. |
| | Pressure relief set too low. | Increase pressure relief. See Adjust Main Pressure Relief in the Adjustment section. <i>NOTE: The pressure relief valve must not be set at a level that causes the motor operating current to exceed the full load amp value* at any time, including when operating in pressure relief.</i> <i>* The full load amp value can be found on the inside cover of the control panel.</i> |
| Platform rises slowly. | Low hydraulic fluid. | Add fluid as needed. See Periodic Maintenance in the Maintenance section. |
| | Contaminated hydraulic system. | Clean and inspect valves. Flush contaminated oil from hydraulic system. Fill system with new oil. See Periodic Maintenance in the Maintenance section. |
| | Damaged or restricted hydraulic hose(s). | Replace damaged hose(s). Remove restriction. |
| | Pressure relief set too low. | Increase pressure relief. See Valve Adjustment section. <i>NOTE: The pressure relief valve RV1 must not be set at a level that causes the motor operating current to exceed the full load amp value* at any time, including when operating in pressure relief.</i> <i>* The full load amp value can be found on the inside cover of the control panel.</i> |
| Pump motor loads down when platform reaches the full raised position. | Pressure relief set too high. | Decrease pressure relief. See Adjust Main Pressure Relief in the Adjustment section. <i>NOTE: The pressure relief valve RV1 must not be set at a level that causes the motor operating current to exceed the full load amp value* at any time, including when operating in pressure relief.</i> <i>* The full load amp value can be found on the inside cover of the control panel.</i> |

TROUBLESHOOTING

| Symptom | Possible Cause | Solution |
|---|---|--|
| Platform does not rise to full height. | Low hydraulic fluid. | Add fluid as needed. See Periodic Maintenance in the Maintenance section. |
| Lip does not stay extended when leveler lowers. | S1 Sequence Valve requires adjustment 1/8" increments clockwise at a time | See Valve Adjustment Procedure Section |
| Platform DOES rise to full height, but lip DOES NOT extend or extend fully. | Low hydraulic fluid. | Add fluid as needed. See Periodic Maintenance in the Maintenance section. |
| | S2 Sequence Valve 2 requires adjustment. 1/8" increments at a time | See Valve Adjustment Procedure Section. |
| Lip does not extend. | S2 Sequence Valve 2 requires adjustment 1/8" increments at a time | See Valve Adjustment Procedure Section. |
| Lip extends almost immediately when the RAISE button is pushed. Platform rises after lip is fully extended. | S2 Sequence Valve 2 requires adjustment. | See Valve Adjustment Procedure Section. |
| Platform locks into "safety" as platform lowers. Lip drops to vertical position. | Platform lowering speed is too fast. NV1 Needle Valve 1 requires adjustment | See Valve Adjustment Procedure Section. |
| | Velocity fuse failed. | <i>Replace Velocity Fuse</i> |
| | Incorrect fluid. | <i>NOTE: Extreme cold weather OR incorrect fluid may cause platform to lock. Adjustment is same. If adjustments and velocity fuse replacement fail to correct problem, fluid replacement may be required.</i> |

Controls

Standard Control Box

Optional Control Box

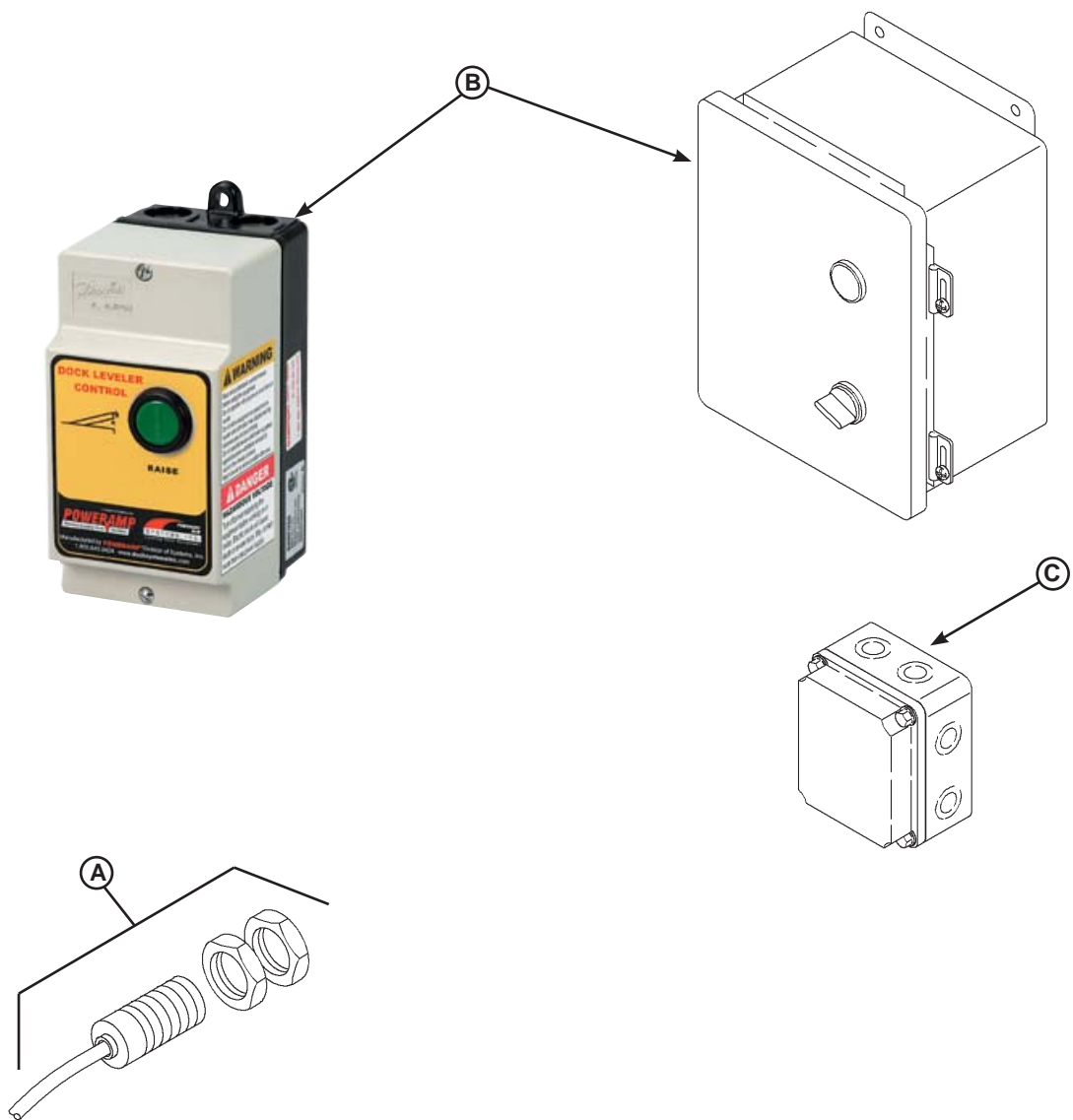

| Item | Quantity | Part Number | Description |
|------|----------|-------------|---|
| A | 1 | 0961-0085 | Proximity Switch with Harness (ARTD Feature Only) |
| B | 1 | * | Push Button Controller |
| C | 1 | 9511-0004 | J-Box, Standard (4 x 4 in. Metal Box) |
| | | 9512-0429 | J-Box, Cold Weather (5 x 5 in. Plastic Box) |

* Provide dock leveler serial number, voltage, phase, and options when calling or faxing controller orders.

PARTS

Frame and Platform

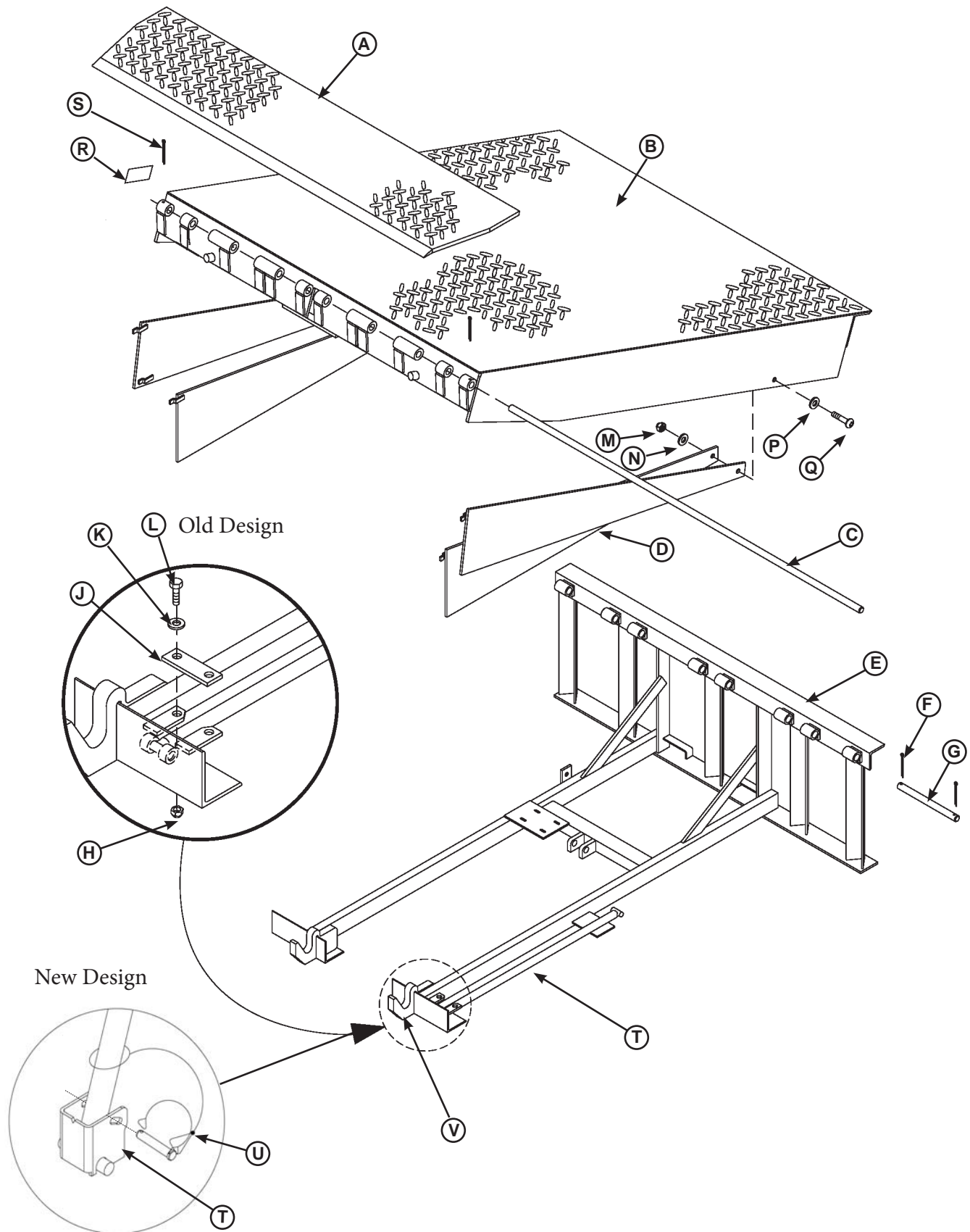

Frame and Platform

| Item | Quantity | Part Number | Description |
|------|----------|------------------------|---|
| A | 1 | 0595-____ ¹ | Lip, Welded Assembly |
| B | 1 | 7823-____ ² | Platform, Welded Assembly |
| C | 1 | 9515-____ ¹ | Pin, Lip Hinge |
| D | 1 | DKIT-9179 | Toe Guards, Sliding 6' (Includes Both Sides) |
| | | DKIT-9180 | Toe Guards, Sliding 8' (Includes Both Sides) |
| | | DKIT-9181 | Toe Guards, Sliding 10' (Includes Both Sides) |
| E | 1 | 9202-____ ¹ | Frame,EH |
| F | 6 | 2101-0047 | Cotter Pin, 1/4 x 2 in. |
| G | 3 | 9202-0002 | Rear Hinge Pin |
| H | 1 | 2101-0039 | Nylon Lock Nut, 5/16-18 UNC |
| J | 1 | 9222-0382 | Lockout Strap, Maintenance Prop |
| K | 1 | 2101-0163 | Washer, 5/16 in., Flat |
| L | 1 | 2101-0012 | Cap Screw, 5/16-18 UNC x 1-1/4 in. |
| M | AR | 2101-0039 | Nylon Lock Nut, 5/16-18 UNC |
| N-P | AR | 2101-0163 | Washer, 5/16 in., Flat |
| Q | AR | 2101-0011 | Cap Screw, 5/16-18 UNC x 1 in. |
| R | 1 | 1751-0010 | Decal, Model/Serial ID |
| S | 2 | 2101-0046 | Cotter Pin, 1/4 x 1-1/4 in. |
| T | 1 | 9225-____ ¹ | Maintenance Prop Rod |
| U | 1 | 9201-0006 | Prop Pin and Clip |
| V | 2 | 8432-0983 | Lip Keeper 16 Inch Lip 20 Inch Pit |
| | | 8432-0984 | Lip Keeper 18 Inch Lip 20 Inch Pit |
| | | 8432-0985 | Lip Keeper 20 Inch Lip 20 Inch Pit |
| | | 8432-0986 | Lip Keeper 16 Inch Lip 24 Inch Pit |
| | | 8432-0987 | Lip Keeper 16 Inch Lip 24 Inch Pit |
| | | 8432-0988 | Lip Keeper 16 Inch Lip 24 Inch Pit |

AR = As Required

¹ Provide dock leveler serial number, platform size, and lip size when calling or faxing orders.

² Provide length and width of inspection plate opening when calling or faxing orders.

* For left/right orientation of dock leveler, see inside back cover of this manual.

PARTS

Hydraulic Components

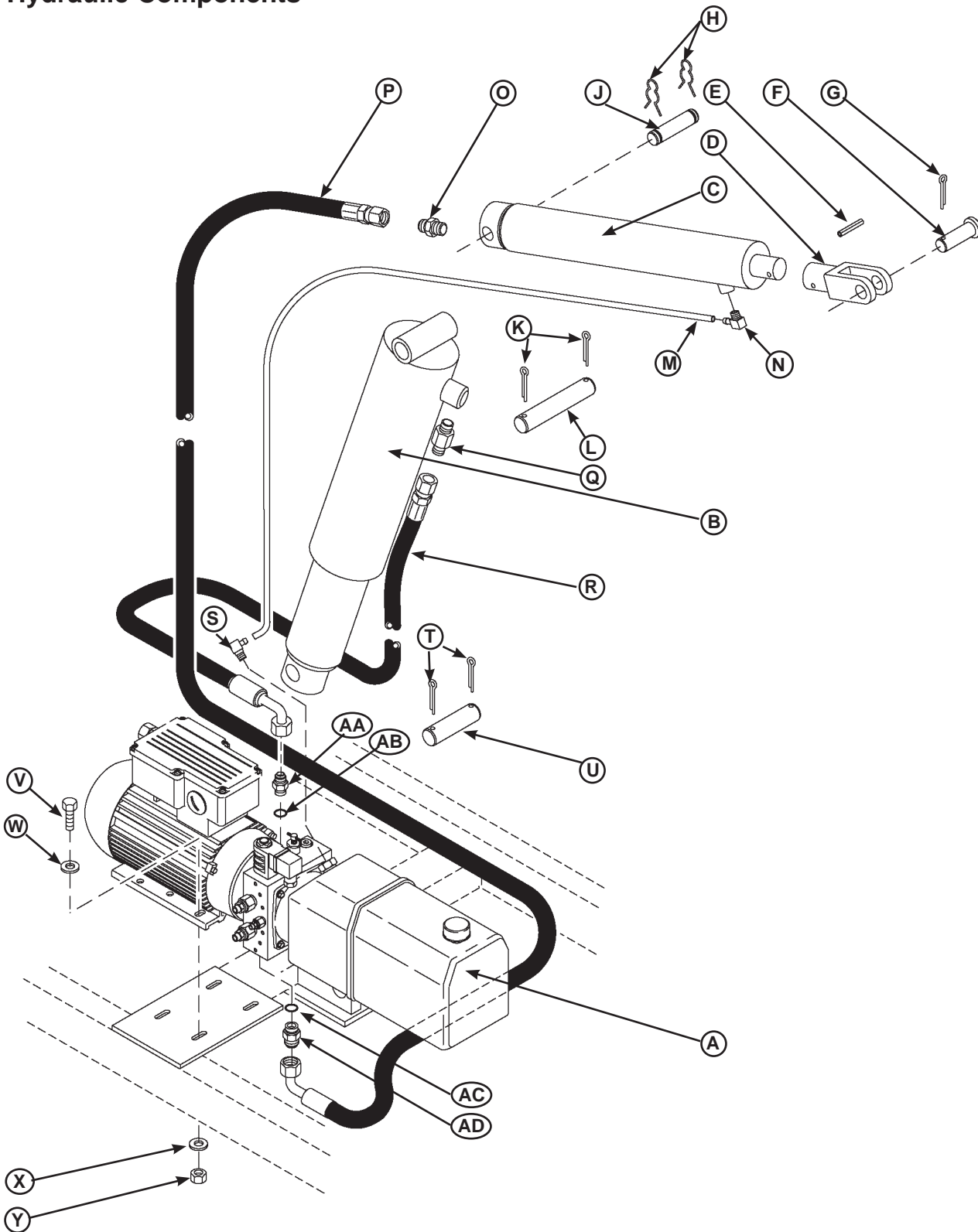

Hydraulic Components

| Item | Quantity | Part Number | Description |
|------|----------|-------------|---|
| A | 1 | 9391-0045 | PPAC, Monarch, 1.25HP, 1PH, 115/230V, |
| | | 9391-0046 | PPAC, Monarch, 1.25HP, 3PH, 208/230/460/575V, |
| B | 1 | 0521-0159 | Cylinder, Platform, in. (mm) Barrel Length |
| C | 1 | 0525-0085 | Lip Cylinder, in. (mm) Barrel Length |
| D | 1 | 0522-0156 | Yoke |
| E | 1 | 0521-0005 | Roll Pin, 1/4" x 1.5" Long |
| F | 1 | 0522-0005 | Clevis Pin, 3/4" x 2", Plated |
| G | 1 | 2101-0045 | Cotter Pin, 1/8" Diameter x 1" Long |
| H | 2 | 2101-0049 | Clip, Hairpin, 5/8" Diameter |
| J | 1 | 9202-0004 | Pin, Lip Cylinder Mounting, 3/4" x 4.38" Long |
| K | 2 | 2101-0047 | Cotter Pin, 1/4" x 2" Long |
| L | 1 | 9202-0058 | Pin, Hoist Cylinder Mounting, 1.25" x 7.5" Long |
| M | 1 | R509-0060 | Tube, Vent (3/8" OD x 1/16" Wall) |
| N | 1 | 0521-0007 | Elbow, 90° 1/4 NPT Male x 1/4 Tube |
| O | 1 | 9301-0111 | Fitting, #6-ORB Male x #8-JIC Male |
| P | 1 | 9904-0128 | Hose, Lip Cylinder, 6' Leveler |
| | | 9904-0129 | Hose, Lip Cylinder, 8' Leveler |
| | | 9904-0130 | Hose, Lip Cylinder, 10' Leveler |
| Q | 1 | 8581-0127 | Velocity Fuse, 4gpm, #8 Male Straight Thread ORB to #8-JIC Male |
| R | 1 | 9904-0128 | Hose, Platform Cylinder |
| S | 1 | 0521-0007 | Elbow, 90° 1/4 NPT Male x 1/4 Tube |
| T | 1 | 2101-0047 | Cotter Pin, 1/4" x 2" Long |
| U | 1 | 9202-0059 | Pin, Hoist Cylinder Mounting, 1.25" x 5.5" Long |
| V | 4 | 2101-0011 | Cap Screw, 5/16-18 UNC x 1 in. |
| W | 4 | 2101-0058 | Washer, 5/16" |
| X | 4 | 2101-0058 | Washer, 5/16" |
| Y | 4 | 2101-0039 | Nylon Lock Nut, 5/16-18 UNC in. |

¹ Provide length and diameter of hose when calling or faxing orders.

² Provide length of lip cylinder when calling or faxing orders.

³ Provide dock leveler serial number, voltage, and phase when calling or faxing orders.

PARTS

Hoke / KTI Power Pack Assembly

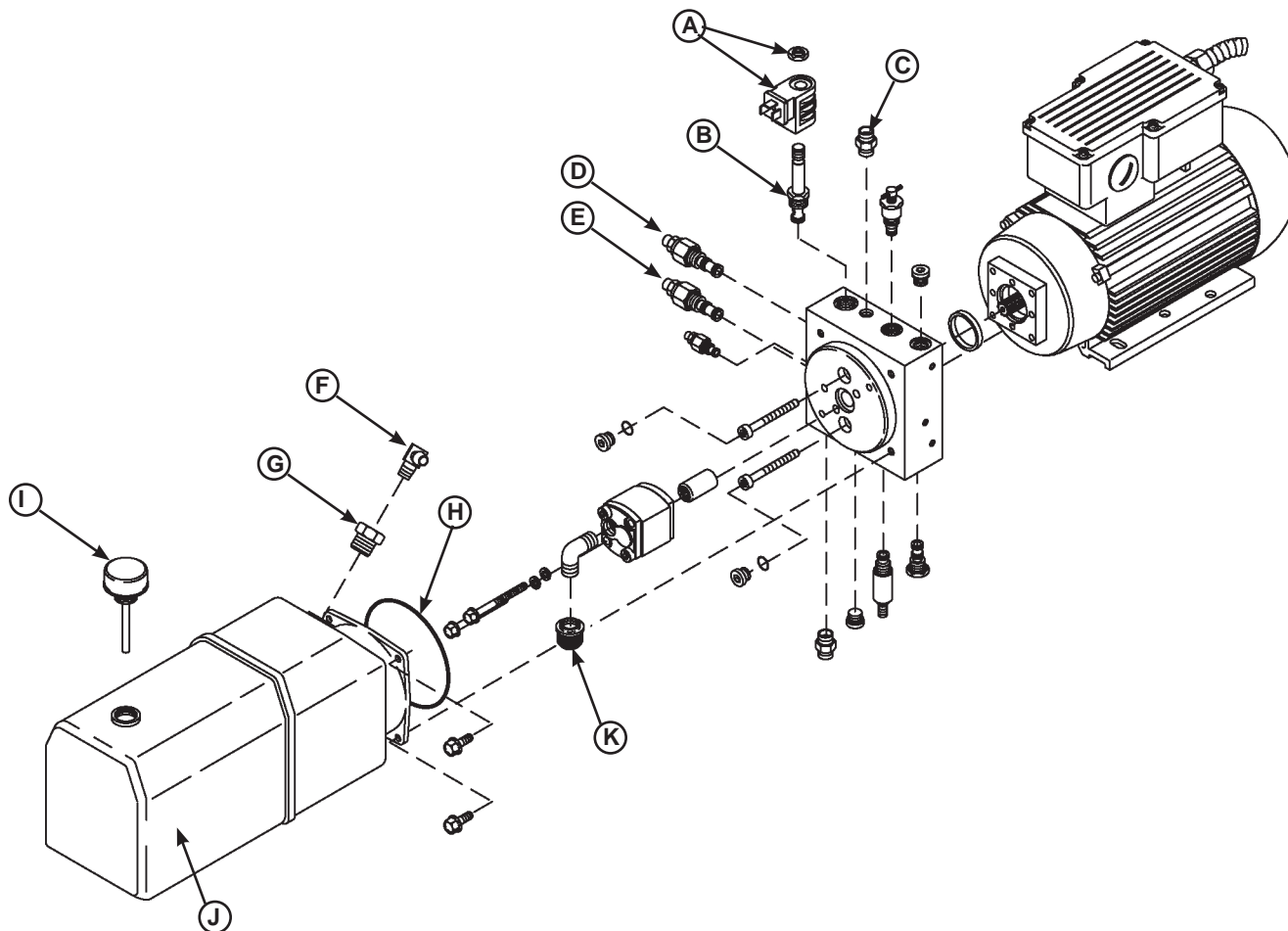

Hoke PPAC Motor

115 Volt 1 PH 220 Volt 1 PH

| | | |
|----|----|-------|
| 1 | 2 | 2-3 |
| | | |
| 3 | 4 | 1 4 |
| | | |
| T1 | T2 | T1 T2 |

208/230 Volt 3 PH 460 Volt 3 PH

| | | | |
|----|----|----|----------|
| 6 | 5 | 4 | 4-5-6 |
| | | | |
| 9 | 8 | 7 | 9 8 7 |
| | | | |
| 3 | 2 | 1 | 3 2 1 |
| | | | |
| T1 | T2 | T3 | T1 T2 T3 |

2nd Design 1Phase
Hoke PPAC Motor.

115 Volt 1 PH 220 Volt 1 PH

| | |
|-------------|------------|
| P1= L1 | P1=L1 |
| T2+T4+T5=L2 | T4+T5= L2 |
| (P2+T3+T8) | (P2) |
| | (T2+T3+T8) |

Hoke / KTI Power Pack Components

| Item | Quantity | Part Number | Description |
|------|----------|-------------|--|
| A | 1 | 8581-0134 | Coil & Nut for 8581-0133 Valve |
| B | 1 | 8581-0133 | Valve, 2 Way Normally Open |
| C | 2 | 9301-0109 | Fitting, #6 SAE to #6 JIC |
| D | 1 | 8581-0128 | Valve, Sequence, S1 (Silver Tip) |
| E | 1 | 8581-0136 | Valve, Sequence, S2 (Red Tip) |
| F | 1 | 0521-0007 | Elbow, 90° 1/4 NPT Male x 1/4 Tube |
| G | 1 | 0521-0161 | Fitting, Reducer, Pipe, 3/4" NPTM to 1/4" NPTF |
| H | 1 | 9391-0032 | O-Ring, Power Pack |
| I | 1 | 9391-0031 | Breather, Hoke Power Pack |
| J | 1 | 9391-0030 | Reservoir, 4 Quart, Hoke H8 |
| K | 1 | 9301-0209 | Strainer, N/A |

¹ Provide dock leveler serial number and type of installation when calling or faxing orders.

² Provide dock leveler serial number, voltage, and phase when calling or faxing orders.

PARTS

Monarch Power Pack Assembly

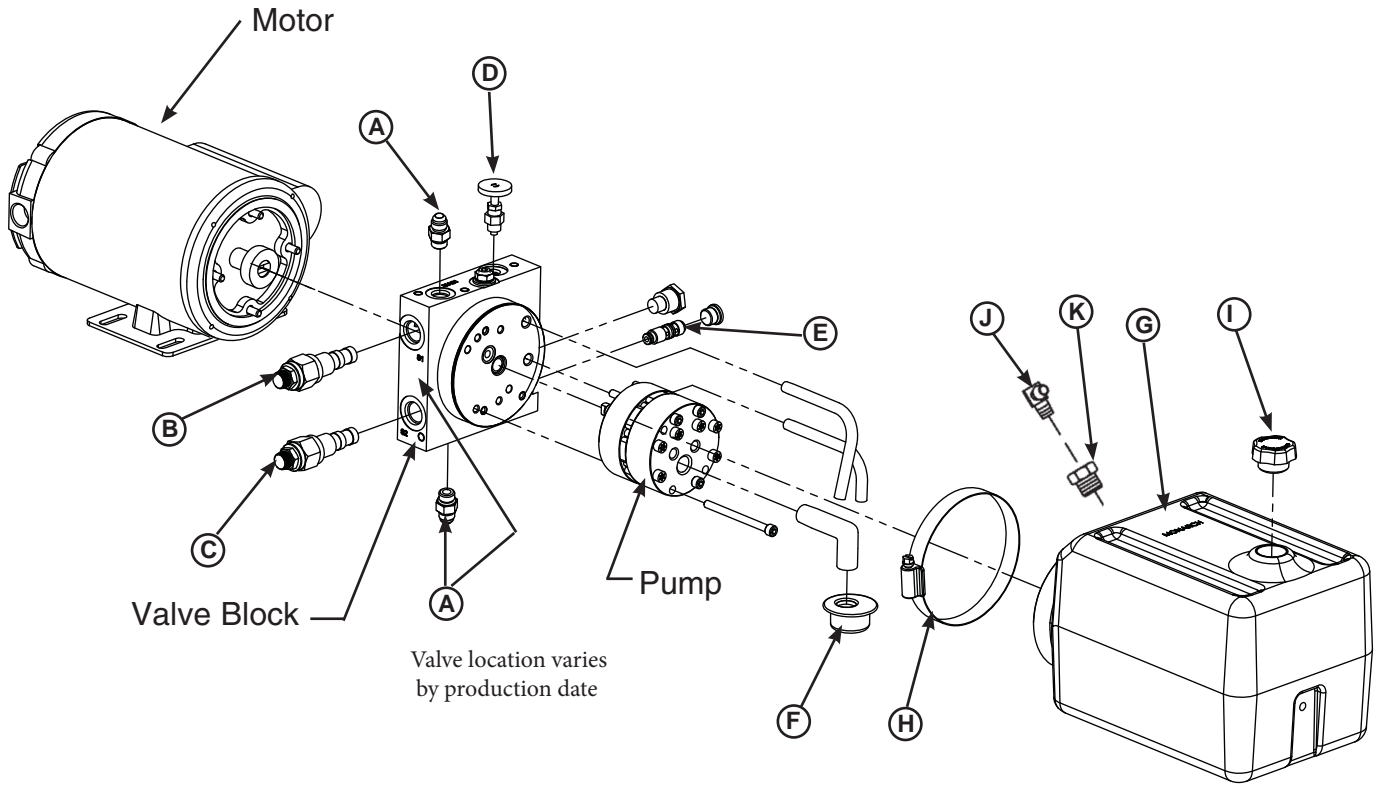

Monarch PPAC Motor

115 Volt 1 PH

230 Volt 1 PH

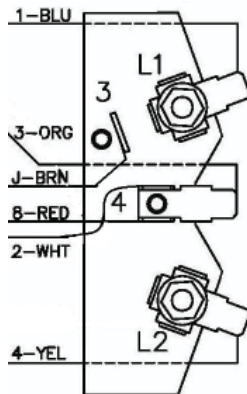
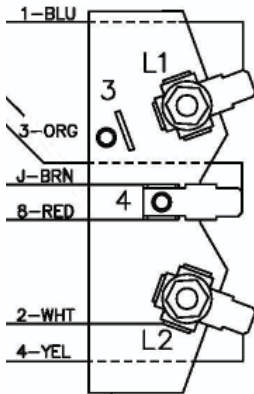

208/230 Volt 3 PH

460 Volt 3 PH

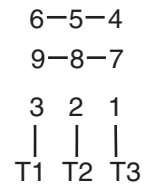
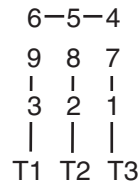

Notes:

Low: Voltage: connect as shown

High: Voltage: Move lead J to Term. 3
move Lead 2 to Term. 4.

Monarch Power Pack Components

| Item | Quantity | Part Number | Description |
|-------------|-----------------|--------------------|--|
| A | 2 | 9301-0109 | Fitting, #6 SAE to #6 JIC |
| B | 1 | 8581-0128 | Valve, Sequence, S1 (Red Tip) |
| C | 1 | 8581-0136 | Valve, Sequence, S2 (Silver Tip) |
| D | 1 | 8581-0151 | Needle valve, Down Speed |
| E | 1 | 8581-0150 | Valve, Pilot Operated Check |
| F | 1 | 9301-0232 | Strainer, Suction |
| G | 1 | 9301-0233 | Reservoir, Plastic |
| H | 1 | 9301-0234 | Clamp, Reservoir |
| I | 1 | 9301-0235 | Breather |
| J | 1 | 0521-0007 | Elbow, 90° 1/4 NPT Male x 1/4 Tube |
| K | 1 | 0521-0161 | Fitting, Reducer, Pipe, 3/4" NPTM to 1/4" NPTF |

PARTS

Operating Instruction

! **DANGER**

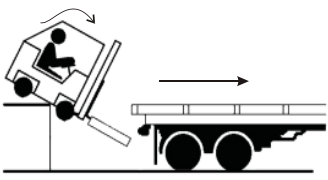

- Read and follow all instructions, warnings and maintenance schedules in the manual and on placards.
- Operation and servicing of dock leveler is restricted to trained personnel.

- Always chock transport vehicle wheels or engage vehicle restraint and set parking brakes before operating dock leveler or beginning to load or unload.
- Before activating dock leveler, ensure lip avoids contact with transport vehicle sides and cargo. If lip does not lower to transport vehicle bed, reposition transport vehicle.
- Ensure the transport vehicle floor supports extended lip or the leveler frame (lip keepers or below dock endload supports) supports the ramp before driving on ramp.
- Stay clear of hinges and front and sides of moving dock leveler.
- Never use hands or equipment to move the ramp or lip.
- Never use damaged or malfunctioning dock leveler. Report problems immediately to supervisor.
- Always store dock leveler and remove people, material, and equipment from ramp before vehicle leaves the dock.
- DO NOT ENTER PIT unless dock leveler is securely supported by the maintenance prop.
- Disconnect power and follow proper lockout/tagout procedures for the dock leveler before entering the dock leveler pit or doing any repair or inspection under the dock leveler.

FAILURE TO FOLLOW THESE INSTRUCTIONS COULD RESULT IN DEATH OR OTHER SERIOUS INJURY.



1.262.255.1510 or 1.800.643.5424

Call for additional placards, or manuals, or with questions regarding proper use, maintenance, and repair of dock leveler.
www.DockSystemsInc.com

1751-0874

OPERATING INSTRUCTIONS

POWERED DOCK LEVELERS

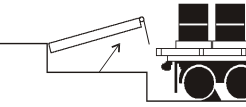

NORMAL OPERATION

- 1 Raise the platform by depressing and holding the RAISE button.
- 2 Hold the RAISE button until the lip is fully extended, then release the RAISE button. The platform will lower until lip is resting on the transport vehicle.

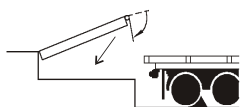

STORING LEVELER

- 1 Depress the RAISE button until the lip is completely folded. When the lip is folded release the RAISE button. The platform will lower returning to the cross-traffic position.



BELOW DOCK ENDLOADING

- (HYDRAULIC ONLY)** Depress and hold the RAISE button until the leveler is fully raised. As the lip starts to extend, release the RAISE button. The leveler will lower to the below dock position provided the lip extension allows the lip to clear the lip keepers.
- (AIR POWERED ONLY)** Depress and hold the RAISE button until the leveler is 12" above dock level. Pull the below dock level chain until the leveler passes the below dock position.
- (HYDRAULIC WITH INFINITE LIP CONTROL)** If equipped raise the platform by depressing and holding the RAISE button. When the lip is just above the lip keepers, simultaneously depress and hold the RAISE button and the LIP OUT button until lip has extended beyond the lip keepers. Release both buttons.

NOTE: If equipped, depressing E-STOP button will stop platform from lowering

| Item | Quantity | Part Number | Description |
|------|----------|-------------|-----------------------|
| A | 1 | 1751-0874 | Operating Instruction |

Weather Seal, Brush Style

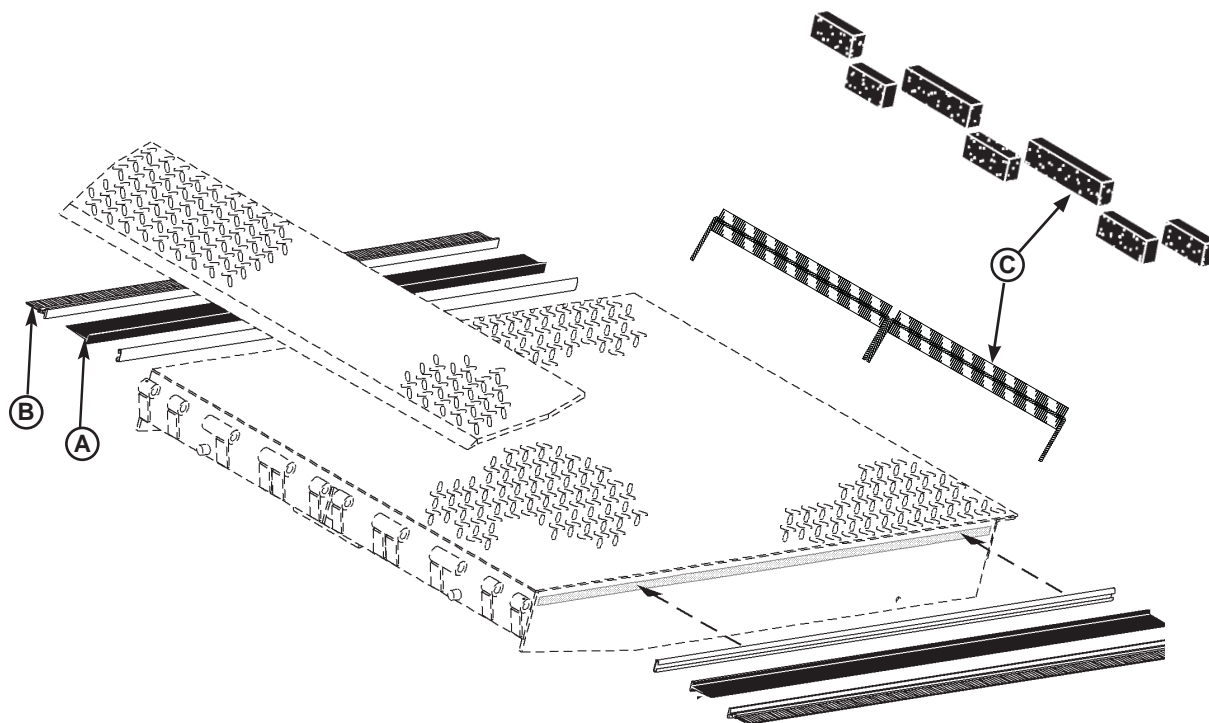

| Item | Quantity | Part Number | Description |
|------|----------|-------------|----------------------------------|
| A | 1 | 0195-0018 | 6' Brush and Track, 1-1/2 in |
| | 1 | 0195-0021 | 8' Brush and Track, 1-1/2 in |
| | 1 | 0195-0024 | 10' Brush and Track, 1-1/2 in |
| | 1 | 0195-0027 | 12' Brush and Track, 1-1/2 in |
| B | 1 | 0192-0097 | 6' Rubber Seal and Track, 1 in |
| | 1 | 0192-0098 | 8' Rubber Seal and Track, 1 in |
| | 1 | 0195-0036 | 10' Rubber Seal and Track, 1 in |
| | 1 | 0195-0039 | 12' Rubber Seal and Track, 1 in |
| C | 1 | 0195-0044 | Rear Brush Weather Seal fits all |
| | 1 | 0192-___* | Foam Rear, Seal Hinge |

AR = As Required

NOTE: Brush or track can be purchased separately as replacement parts. Contact factory for part numbers.
Kits are for existing dock leveler without weather seal.

* Provide dock leveler serial number and size of platform when calling or faxing orders.

*Provide width of weatherstrip when replacing existing seals

Electrical

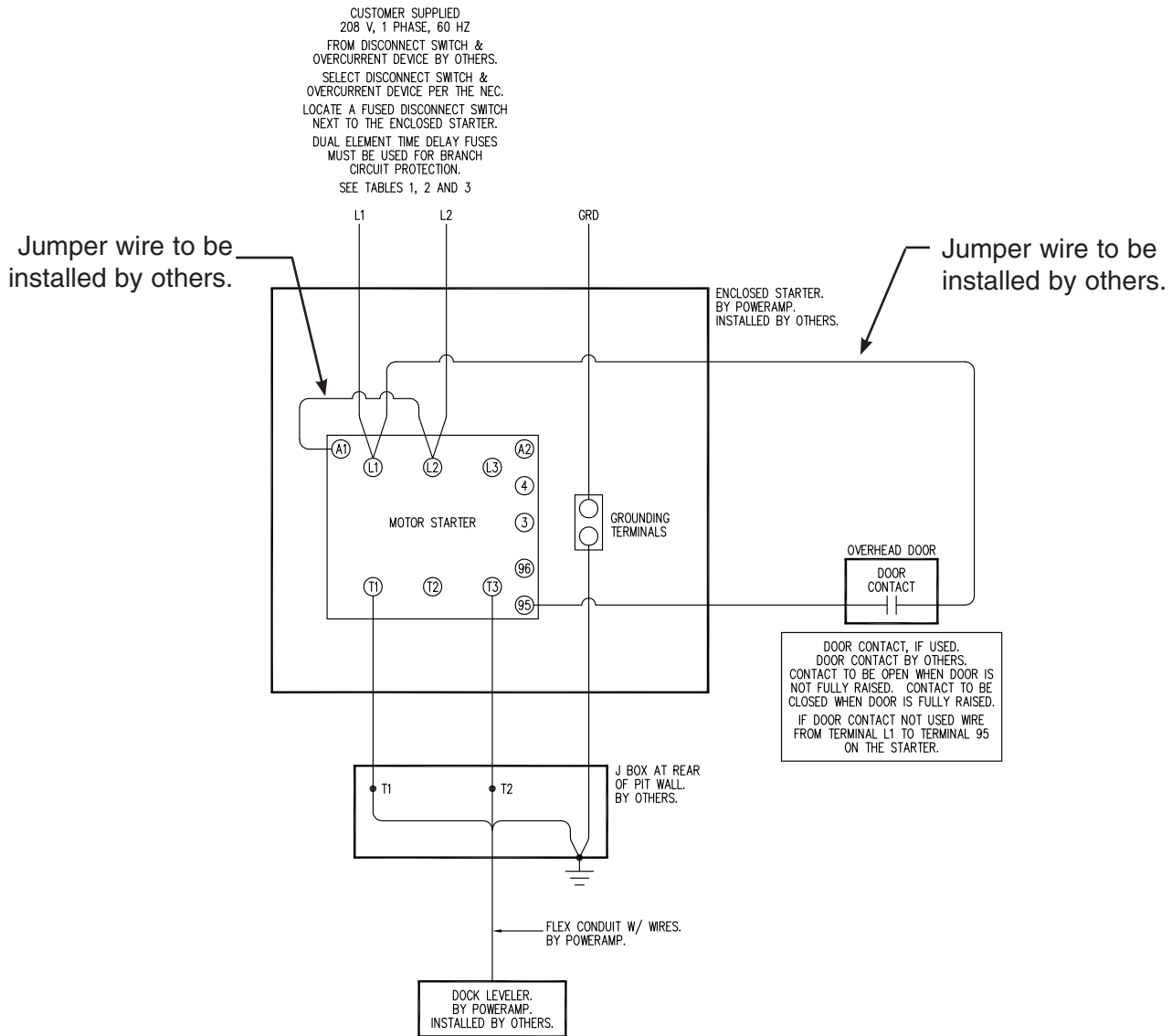

Note:

1 Phase control box show jumper will be the same for 3 phase control box's.

Customer Information

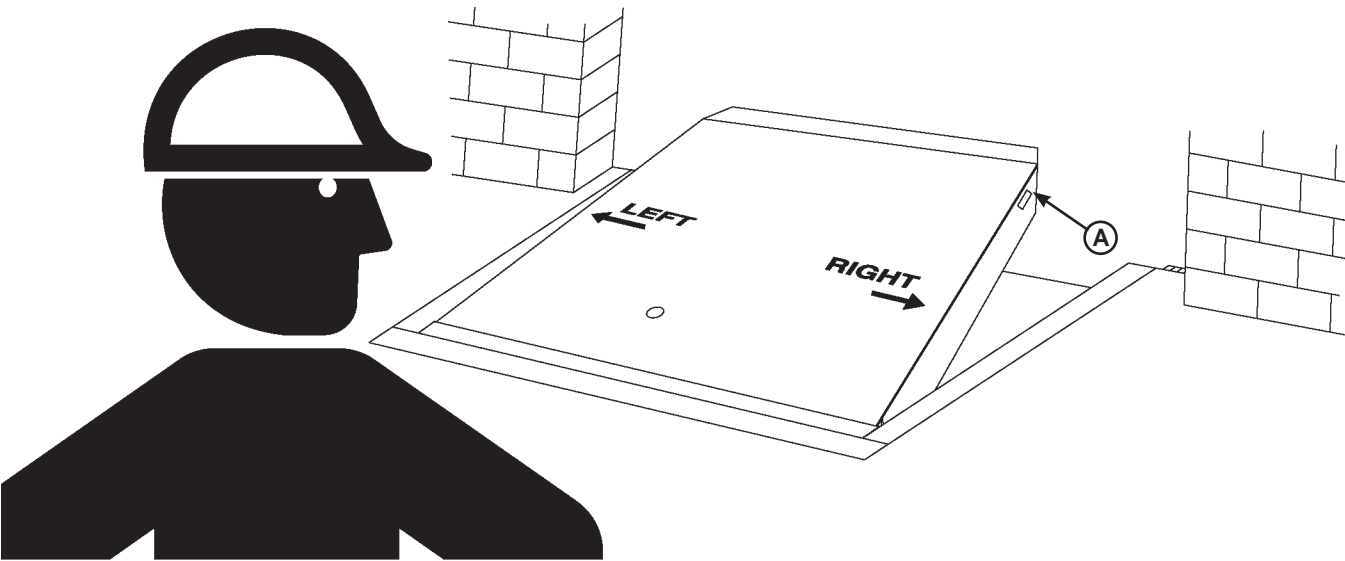

NOTE: Refer to illustration for left/right orientation of dock leveler.

The model/serial number decal (A) is located on the right platform joist near the front (lip) of dock leveler.

When you receive your EH dock leveler, write down the dock leveler model and serial number in the form provided. This will help ensure safe keeping of the numbers in the event the model/serial number decal (A) becomes lost or damaged.

Also, write down Systems, Inc.'s job number, the company that installed the dock leveler, and the original owner's name. This will all help to identify the specific dock leveler if more information is required.

When ordering, use part numbers and description to help identify the item ordered. Do not use "item" numbers. These are only for locating the position of the parts. Always give dock leveler MODEL NUMBER and/or SERIAL NUMBER.

For service, call or contact:

Systems, Inc.
P.O. Box 309
Germantown, WI 53022

Phone: (800) 643-5424
Fax: (262) 255-5917

| | |
|--|----------------|
| <u>Dock Leveler Information</u> | |
| Model | _____ |
| Serial No. | _____ |
| Systems, Inc., Job No. | _____ |
| <u>Original Owner Information</u> | |
| Name | _____ |
| Address | _____ _____ |
| <u>Installer Information</u> | |
| Name | _____ |
| Address | _____ _____ |
| Date of Installation | _____ |

STANDARD PRODUCT WARRANTY

SYSTEMS, INC. warrants that its products will be free from defects in design, materials and workmanship for a period of one (1) year from the date of shipment. All claims for breach of this warranty must be made within 30 days after the defect is or can with reasonable care, be detected. In no event shall any claim be made more than 30 days after this warranty has expired. In order to be entitled to the benefits of this warranty, the product must have been properly installed, maintained and operated in accordance with all manufacturer's recommendations and/or specified design parameters and not otherwise have been subject to abuse, misuse, misapplication, acts of nature, overloading, unauthorized repair or modification, application in a corrosive environment or lack of maintenance. Periodic lubrication, adjustment and inspection in accordance with all manufacturers' recommendations are the sole responsibility of the Owner/User.

In the event of a defect, as determined by SYSTEMS INC., covered by this warranty, SYSTEMS INC. shall remedy such defect by repairing or replacing any defective equipment or parts, bearing the cost for the parts, labor and transportation. This shall be exclusive remedy for all claims whether based on contract, negligence or strict liability.

WARRANTY LIMITATIONS

THE ABOVE WARRANTIES ARE IN LIEU OF ANY OTHER WARRANTIES, WHETHER EXPRESSED OR IMPLIED, INCLUDING BUT NOT LIMITED TO ANY IMPLIED WARRANTY OF MERCHANTABILITY OR FITNESS FOR A PARTICULAR PURPOSE. SYSTEMS INC. AND ITS SUBSIDIARIES SHALL NOT IN ANY EVENT BE LIABLE TO ANYONE, INCLUDING THIRD PARTIES, FOR INCIDENTAL, CONSEQUENTIAL OR SPECIAL DAMAGES OF ANY KIND INCLUDING BUT NOT LIMITED TO, BREACH OF WARRANTY, LOSS OF USE, LOSS OF PROFIT, INTERRUPTION OF BUSINESS OR LOSS OF GOODWILL.

PRODUCT SPECIFIC WARRANTY "EH" SERIES LEVELER

In addition to the "Standard Product Warranty" provided with all Poweramp® Products, Systems Inc., guarantees materials, components and workmanship to be free of defects for the following extended periods:

- Structural Warranty – For a period of ten (10) years from the date of shipment, product will carry a prorated structural warranty. This warranty specifically applies to; the deck section, lip section, frame, rear hinge assembly and front hinge assembly only. This warranty covers structural repairs to or replacement of dock leveler in Systems Inc sole discretion and expense including reasonable labor, materials, freight and travel. If Systems Inc. determines replacement is necessary, it will provide the original purchaser with a credit toward the purchase of the new replacement Systems Inc. product in the amount equal to the original purchase price of the warranted product F.O.B. point of manufacture, discounted on a ten year straight line basis by the number of years of use prior to replacement.
- Hydraulic Warranty – For a period of three (3) years from date of shipment, this warranty specifically applies to; the hydraulic pump and motor, all hydraulic cylinders, hydraulic pressure lines and fittings and fluid logic control assembly only.