

HP ProLiant DL320 Generation 5 Server Maintenance and Service Guide



Part Number 419195-002
November 2007 (Second Edition)

© Copyright 2006, 2007 Hewlett-Packard Development Company, L.P.

The information contained herein is subject to change without notice. The only warranties for HP products and services are set forth in the express warranty statements accompanying such products and services. Nothing herein should be construed as constituting an additional warranty. HP shall not be liable for technical or editorial errors or omissions contained herein.

Microsoft and Windows are U.S. registered trademarks of Microsoft Corporation.

Intel, Xeon, and Celeron are trademarks or registered trademarks of Intel Corporation or its subsidiaries in the United States and other countries.

Audience assumptions

This guide is for an experienced service technician. HP assumes you are qualified in the servicing of computer equipment and trained in recognizing hazards in products with hazardous energy levels and are familiar with weight and stability precautions for rack installations.

Contents

Customer self repair	5
Parts only warranty service	5
Illustrated parts catalog	16
Mechanical components	16
System components	19
Removal and replacement procedures	23
Required tools	23
Safety considerations	23
Preventing electrostatic discharge	23
Symbols on equipment	23
Rack warnings	24
Server warnings and cautions	25
Preparation procedures	25
Extend the server from the rack	25
Power down the server	26
Remove the server from the rack	26
Access panel	27
Hard drives	27
Hard drive blanks	28
SAS/SATA backplane	28
Air baffle	29
Fan assembly	30
BBWC battery holder	31
BBWC battery	31
Media cage	32
Optical drive	33
Diskette drive	34
Front video connector	35
Power button/LED board	36
Front bezel	37
PCI riser board assembly	39
Expansion boards	39
Storage controller	40
PCI Express or PCI-X riser board	41
DIMMs	42
Memory options	42
DIMM installation guidelines	42
Interleaving and non-interleaving memory configuration	43
Power supply	43
Heatsink	44
Processor	46
System board	50
Battery	56
Cabling	58

Server cable routing	58
Embedded SATA controller cable routing	58
Optional SAS/SATA controller cable routing	59
Slot 2.....	59
Slot 1.....	60
Video connector option cable routing	60
Battery-backed write cache cable routing	61
Diagnostic tools	62
Troubleshooting resources	62
HP Insight Diagnostics.....	62
HP Insight Diagnostics survey functionality	62
Integrated Management Log	63
Array Diagnostic Utility	63
HP Systems Insight Manager.....	63
Component identification.....	64
Front panel components	64
Front panel LEDs and buttons	65
Rear panel components.....	66
PCI expansion slot definitions.....	66
Rear panel LEDs.....	67
System board components.....	68
System maintenance switch.....	68
NMI functionality.....	69
System board LEDs	70
System LEDs and internal health LED combinations.....	71
Internal USB connector.....	72
SATA and SAS device numbers.....	72
Fan assembly location.....	73
Specifications.....	74
Environmental specifications	74
Server specifications	74
Acronyms and abbreviations.....	76
Index.....	78

Customer self repair

HP products are designed with many Customer Self Repair (CSR) parts to minimize repair time and allow for greater flexibility in performing defective parts replacement. If during the diagnosis period HP (or HP service providers or service partners) identifies that the repair can be accomplished by the use of a CSR part, HP will ship that part directly to you for replacement. There are two categories of CSR parts:

- **Mandatory**—Parts for which customer self repair is mandatory. If you request HP to replace these parts, you will be charged for the travel and labor costs of this service.
- **Optional**—Parts for which customer self repair is optional. These parts are also designed for customer self repair. If, however, you require that HP replace them for you, there may or may not be additional charges, depending on the type of warranty service designated for your product.

NOTE: Some HP parts are not designed for customer self repair. In order to satisfy the customer warranty, HP requires that an authorized service provider replace the part. These parts are identified as "No" in the Illustrated Parts Catalog.

Based on availability and where geography permits, CSR parts will be shipped for next business day delivery. Same day or four-hour delivery may be offered at an additional charge where geography permits. If assistance is required, you can call the HP Technical Support Center and a technician will help you over the telephone. HP specifies in the materials shipped with a replacement CSR part whether a defective part must be returned to HP. In cases where it is required to return the defective part to HP, you must ship the defective part back to HP within a defined period of time, normally five (5) business days. The defective part must be returned with the associated documentation in the provided shipping material. Failure to return the defective part may result in HP billing you for the replacement. With a customer self repair, HP will pay all shipping and part return costs and determine the courier/carrier to be used.

For more information about HP's Customer Self Repair program, contact your local service provider. For the North American program, refer to the HP website (<http://www.hp.com/go/selfrepair>).

Parts only warranty service

Your HP Limited Warranty may include a parts only warranty service. Under the terms of parts only warranty service, HP will provide replacement parts free of charge.

For parts only warranty service, CSR part replacement is mandatory. If you request HP to replace these parts, you will be charged for the travel and labor costs of this service.

Réparation par le client (CSR)

Les produits HP comportent de nombreuses pièces CSR (Customer Self Repair = réparation par le client) afin de minimiser les délais de réparation et faciliter le remplacement des pièces défectueuses. Si pendant la période de diagnostic, HP (ou ses partenaires ou mainteneurs agréés) détermine que la réparation peut être effectuée à l'aide d'une pièce CSR, HP vous l'envoie directement. Il existe deux catégories de pièces CSR:

- **Obligatoire** - Pièces pour lesquelles la réparation par le client est obligatoire. Si vous demandez à HP de remplacer ces pièces, les coûts de déplacement et main d'œuvre du service vous seront facturés.
- **Facultatif** - Pièces pour lesquelles la réparation par le client est facultative. Ces pièces sont également conçues pour permettre au client d'effectuer lui-même la réparation. Toutefois, si vous demandez à HP de remplacer ces pièces, l'intervention peut ou non vous être facturée, selon le type de garantie applicable à votre produit.

REMARQUE: Certaines pièces HP ne sont pas conçues pour permettre au client d'effectuer lui-même la réparation. Pour que la garantie puisse s'appliquer, HP exige que le remplacement de la pièce soit effectué par un Mainteneur Agréé. Ces pièces sont identifiées par la mention "Non" dans le Catalogue illustré.

Les pièces CSR sont livrées le jour ouvré suivant, dans la limite des stocks disponibles et selon votre situation géographique. Si votre situation géographique le permet et que vous demandez une livraison le jour même ou dans les 4 heures, celle-ci vous sera facturée. Pour bénéficier d'une assistance téléphonique, appelez le Centre d'assistance technique HP. Dans les documents envoyés avec la pièce de rechange CSR, HP précise s'il est nécessaire de lui retourner la pièce défectueuse. Si c'est le cas, vous devez le faire dans le délai indiqué, généralement cinq (5) jours ouvrés. La pièce et sa documentation doivent être retournées dans l'emballage fourni. Si vous ne retournez pas la pièce défectueuse, HP se réserve le droit de vous facturer les coûts de remplacement. Dans le cas d'une pièce CSR, HP supporte l'ensemble des frais d'expédition et de retour, et détermine la société de courses ou le transporteur à utiliser.

Pour plus d'informations sur le programme CSR de HP, contactez votre Mainteneur Agréé local. Pour plus d'informations sur ce programme en Amérique du Nord, consultez le site Web HP (<http://www.hp.com/go/selfrepair>).

Service de garantie "pièces seules"

Votre garantie limitée HP peut inclure un service de garantie "pièces seules". Dans ce cas, les pièces de rechange fournies par HP ne sont pas facturées.

Dans le cadre de ce service, la réparation des pièces CSR par le client est obligatoire. Si vous demandez à HP de remplacer ces pièces, les coûts de déplacement et main d'œuvre du service vous seront facturés.

Riparazione da parte del cliente

Per abbreviare i tempi di riparazione e garantire una maggiore flessibilità nella sostituzione di parti difettose, i prodotti HP sono realizzati con numerosi componenti che possono essere riparati direttamente dal cliente (CSR, Customer Self Repair). Se in fase di diagnostica HP (o un centro di servizi o di assistenza HP) identifica il guasto come riparabile mediante un ricambio CSR, HP lo spedisirà direttamente al cliente per la sostituzione. Vi sono due categorie di parti CSR:

- **Obbligatorie** – Parti che devono essere necessariamente riparate dal cliente. Se il cliente ne affida la riparazione ad HP, deve sostenere le spese di spedizione e di manodopera per il servizio.
- **Opzionali** – Parti la cui riparazione da parte del cliente è facultativa. Si tratta comunque di componenti progettati per questo scopo. Se tuttavia il cliente ne richiede la sostituzione ad HP, potrebbe dover sostenere spese addizionali a seconda del tipo di garanzia previsto per il prodotto.

NOTA: alcuni componenti HP non sono progettati per la riparazione da parte del cliente. Per rispettare la garanzia, HP richiede che queste parti siano sostituite da un centro di assistenza autorizzato. Tali parti sono identificate da un "No" nel Catalogo illustrato dei componenti.

In base alla disponibilità e alla località geografica, le parti CSR vengono spedite con consegna entro il giorno lavorativo seguente. La consegna nel giorno stesso o entro quattro ore è offerta con un supplemento di costo solo in alcune zone. In caso di necessità si può richiedere l'assistenza telefonica di un addetto del centro di supporto tecnico HP. Nel materiale fornito con una parte di ricambio CSR, HP specifica se il cliente deve restituire dei componenti. Qualora sia richiesta la resa ad HP del componente difettoso, lo si deve spedire ad HP entro un determinato periodo di tempo, generalmente cinque (5) giorni lavorativi. Il componente difettoso deve essere restituito con la documentazione associata nell'imballo di spedizione fornito. La mancata restituzione del componente può comportare la fatturazione del ricambio da parte di HP. Nel caso di riparazione da parte del cliente, HP sostiene tutte le spese di spedizione e resa e sceglie il corriere/vettore da utilizzare.

Per ulteriori informazioni sul programma CSR di HP contattare il centro di assistenza di zona. Per il programma in Nord America fare riferimento al sito Web HP (<http://www.hp.com/go/selfrepair>).

Servizio di garanzia per i soli componenti

La garanzia limitata HP può includere un servizio di garanzia per i soli componenti. Nei termini di garanzia del servizio per i soli componenti, HP fornirà gratuitamente le parti di ricambio.

Per il servizio di garanzia per i soli componenti è obbligatoria la formula CSR che prevede la riparazione da parte del cliente. Se il cliente invece richiede la sostituzione ad HP, dovrà sostenere le spese di spedizione e di manodopera per il servizio.

Customer Self Repair

HP Produkte enthalten viele CSR-Teile (Customer Self Repair), um Reparaturzeiten zu minimieren und höhere Flexibilität beim Austausch defekter Bauteile zu ermöglichen. Wenn HP (oder ein HP Servicepartner) bei der Diagnose feststellt, dass das Produkt mithilfe eines CSR-Teils repariert werden kann, sendet Ihnen HP dieses Bauteil zum Austausch direkt zu. CSR-Teile werden in zwei Kategorien unterteilt:

- **Zwingend** – Teile, für die das Customer Self Repair-Verfahren zwingend vorgegeben ist. Wenn Sie den Austausch dieser Teile von HP vornehmen lassen, werden Ihnen die Anfahrt- und Arbeitskosten für diesen Service berechnet.
- **Optional** – Teile, für die das Customer Self Repair-Verfahren optional ist. Diese Teile sind auch für Customer Self Repair ausgelegt. Wenn Sie jedoch den Austausch dieser Teile von HP vornehmen lassen möchten, können bei diesem Service je nach den für Ihr Produkt vorgesehenen Garantiebedingungen zusätzliche Kosten anfallen.

HINWEIS: Einige Teile sind nicht für Customer Self Repair ausgelegt. Um den Garantieanspruch des Kunden zu erfüllen, muss das Teil von einem HP Servicepartner ersetzt werden. Im illustrierten Teilekatalog sind diese Teile mit „No“ bzw. „Nein“ gekennzeichnet.

CSR-Teile werden abhängig von der Verfügbarkeit und vom Lieferziel am folgenden Geschäftstag geliefert. Für bestimmte Standorte ist eine Lieferung am selben Tag oder innerhalb von vier Stunden gegen einen Aufpreis verfügbar. Wenn Sie Hilfe benötigen, können Sie das HP technische Support Center

anrufen und sich von einem Mitarbeiter per Telefon helfen lassen. Den Materialien, die mit einem CSR-Ersatzteil geliefert werden, können Sie entnehmen, ob das defekte Teil an HP zurückgeschickt werden muss. Wenn es erforderlich ist, das defekte Teil an HP zurückzuschicken, müssen Sie dies innerhalb eines vorgegebenen Zeitraums tun, in der Regel innerhalb von fünf (5) Geschäftstagen. Das defekte Teil muss mit der zugehörigen Dokumentation in der Verpackung zurückgeschickt werden, die im Lieferumfang enthalten ist. Wenn Sie das defekte Teil nicht zurückschicken, kann HP Ihnen das Ersatzteil in Rechnung stellen. Im Falle von Customer Self Repair kommt HP für alle Kosten für die Lieferung und Rücksendung auf und bestimmt den Kurier-/Frachtdienst.

Weitere Informationen über das HP Customer Self Repair Programm erhalten Sie von Ihrem Servicepartner vor Ort. Informationen über das CSR-Programm in Nordamerika finden Sie auf der HP Website unter (<http://www.hp.com/go/selfrepair>).

Parts-only Warranty Service (Garantieservice ausschließlich für Teile)

Ihre HP Garantie umfasst möglicherweise einen Parts-only Warranty Service (Garantieservice ausschließlich für Teile). Gemäß den Bestimmungen des Parts-only Warranty Service stellt HP Ersatzteile kostenlos zur Verfügung.

Für den Parts-only Warranty Service ist das CSR-Verfahren zwingend vorgegeben. Wenn Sie den Austausch dieser Teile von HP vornehmen lassen, werden Ihnen die Anfahrt- und Arbeitskosten für diesen Service berechnet.

Reparaciones del propio cliente

Los productos de HP incluyen muchos componentes que el propio usuario puede reemplazar (*Customer Self Repair*, CSR) para minimizar el tiempo de reparación y ofrecer una mayor flexibilidad a la hora de realizar sustituciones de componentes defectuosos. Si, durante la fase de diagnóstico, HP (o los proveedores o socios de servicio de HP) identifica que una reparación puede llevarse a cabo mediante el uso de un componente CSR, HP le enviará dicho componente directamente para que realice su sustitución. Los componentes CSR se clasifican en dos categorías:

- **Obligatorio:** componentes para los que la reparación por parte del usuario es obligatoria. Si solicita a HP que realice la sustitución de estos componentes, tendrá que hacerse cargo de los gastos de desplazamiento y de mano de obra de dicho servicio.
- **Opcional:** componentes para los que la reparación por parte del usuario es opcional. Estos componentes también están diseñados para que puedan ser reparados por el usuario. Sin embargo, si precisa que HP realice su sustitución, puede o no conllevar costes adicionales, dependiendo del tipo de servicio de garantía correspondiente al producto.

NOTA: Algunos componentes no están diseñados para que puedan ser reparados por el usuario. Para que el usuario haga valer su garantía, HP pone como condición que un proveedor de servicios autorizado realice la sustitución de estos componentes. Dichos componentes se identifican con la palabra "No" en el catálogo ilustrado de componentes.

Según la disponibilidad y la situación geográfica, los componentes CSR se enviarán para que lleguen a su destino al siguiente día laborable. Si la situación geográfica lo permite, se puede solicitar la entrega en el mismo día o en cuatro horas con un coste adicional. Si precisa asistencia técnica, puede llamar al

Centro de asistencia técnica de HP y recibirá ayuda telefónica por parte de un técnico. Con el envío de materiales para la sustitución de componentes CSR, HP especificará si los componentes defectuosos deberán devolverse a HP. En aquellos casos en los que sea necesario devolver algún componente a HP, deberá hacerlo en el periodo de tiempo especificado, normalmente cinco días laborables. Los componentes defectuosos deberán devolverse con toda la documentación relacionada y con el embalaje de envío. Si no enviara el componente defectuoso requerido, HP podrá cobrarle por el de sustitución. En el caso de todas sustituciones que lleve a cabo el cliente, HP se hará cargo de todos los gastos de envío y devolución de componentes y escogerá la empresa de transporte que se utilice para dicho servicio.

Para obtener más información acerca del programa de Reparaciones del propio cliente de HP, póngase en contacto con su proveedor de servicios local. Si está interesado en el programa para Norteamérica, visite la página web de HP siguiente (<http://www.hp.com/go/selfrepair>).

Servicio de garantía exclusivo de componentes

La garantía limitada de HP puede que incluya un servicio de garantía exclusivo de componentes. Según las condiciones de este servicio exclusivo de componentes, HP le facilitará los componentes de repuesto sin cargo adicional alguno.

Para este servicio de garantía exclusivo de componentes, es obligatoria la sustitución de componentes por parte del usuario (CSR). Si solicita a HP que realice la sustitución de estos componentes, tendrá que hacerse cargo de los gastos de desplazamiento y de mano de obra de dicho servicio.

Customer Self Repair

Veel onderdelen in HP producten zijn door de klant zelf te repareren, waardoor de reparatieduur tot een minimum beperkt kan blijven en de flexibiliteit in het vervangen van defecte onderdelen groter is. Deze onderdelen worden CSR-onderdelen (Customer Self Repair) genoemd. Als HP (of een HP Service Partner) bij de diagnose vaststelt dat de reparatie kan worden uitgevoerd met een CSR-onderdeel, verzendt HP dat onderdeel rechtstreeks naar u, zodat u het defecte onderdeel daarmee kunt vervangen. Er zijn twee categorieën CSR-onderdelen:

- **Verplicht:** Onderdelen waarvoor reparatie door de klant verplicht is. Als u HP verzoekt deze onderdelen voor u te vervangen, worden u voor deze service reiskosten en arbeidsloon in rekening gebracht.
- **Optioneel:** Onderdelen waarvoor reparatie door de klant optioneel is. Ook deze onderdelen zijn ontworpen voor reparatie door de klant. Als u echter HP verzoekt deze onderdelen voor u te vervangen, kunnen daarvoor extra kosten in rekening worden gebracht, afhankelijk van het type garantieservice voor het product.

OPMERKING: Sommige HP onderdelen zijn niet ontwikkeld voor reparatie door de klant. In verband met de garantievoorzwaarden moet het onderdeel door een geautoriseerde Service Partner worden vervangen. Deze onderdelen worden in de geïllustreerde onderdelencatalogus aangemerkt met "Nee".

Afhankelijk van de leverbaarheid en de locatie worden CSR-onderdelen verzonden voor levering op de eerstvolgende werkdag. Levering op dezelfde dag of binnen vier uur kan tegen meerkosten worden aangeboden, indien dit mogelijk is gezien de locatie. Indien assistentie gewenst is, belt u een HP Service Partner om via de telefoon technische ondersteuning te ontvangen. HP vermeldt in de documentatie bij het vervangende CSR-onderdeel of het defecte onderdeel aan HP moet worden geretourneerd. Als het defecte onderdeel aan HP moet worden teruggezonden, moet u het defecte onderdeel binnen een bepaalde

periode, gewoonlijk vijf (5) werkdagen, retourneren aan HP. Het defecte onderdeel moet met de bijbehorende documentatie worden geretourneerd in het meegeleverde verpakkingsmateriaal. Als u het defecte onderdeel niet terugzendt, kan HP u voor het vervangende onderdeel kosten in rekening brengen. Bij reparatie door de klant betaalt HP alle verzendkosten voor het vervangende en geretourneerde onderdeel en kiest HP zelf welke koerier/transportonderneming hiervoor wordt gebruikt.

Neem contact op met een Service Partner voor meer informatie over het Customer Self Repair programma van HP. Informatie over Service Partners vindt u op de HP website (<http://www.hp.nl/services/servicepartners>).

Garantieservice "Parts Only"

Het is mogelijk dat de HP garantie alleen de garantieservice "Parts Only" omvat. Volgens de bepalingen van de Parts Only garantieservice zal HP kosteloos vervangende onderdelen ter beschikking stellen.

Voor de Parts Only garantieservice is vervanging door CSR-onderdelen verplicht. Als u HP verzoekt deze onderdelen voor u te vervangen, worden u voor deze service reiskosten en arbeidsloon in rekening gebracht.

Reparo feito pelo cliente

Os produtos da HP são projetados com muitas peças para reparo feito pelo cliente (CSR) de modo a minimizar o tempo de reparo e permitir maior flexibilidade na substituição de peças com defeito. Se, durante o período de diagnóstico, a HP (ou fornecedores/parceiros de serviço da HP) concluir que o reparo pode ser efetuado pelo uso de uma peça CSR, a peça de reposição será enviada diretamente ao cliente. Existem duas categorias de peças CSR:

- **Obrigatória** – Peças cujo reparo feito pelo cliente é obrigatório. Se desejar que a HP substitua essas peças, serão cobradas as despesas de transporte e mão-de-obra do serviço.
- **Opcional** – Peças cujo reparo feito pelo cliente é opcional. Essas peças também são projetadas para o reparo feito pelo cliente. No entanto, se desejar que a HP as substitua, pode haver ou não a cobrança de taxa adicional, dependendo do tipo de serviço de garantia destinado ao produto.

OBSERVAÇÃO: Algumas peças da HP não são projetadas para o reparo feito pelo cliente. A fim de cumprir a garantia do cliente, a HP exige que um técnico autorizado substitua a peça. Essas peças estão identificadas com a marca "No" (Não), no catálogo de peças ilustrado.

Conforme a disponibilidade e o local geográfico, as peças CSR serão enviadas no primeiro dia útil após o pedido. Onde as condições geográficas permitirem, a entrega no mesmo dia ou em quatro horas pode ser feita mediante uma taxa adicional. Se precisar de auxílio, entre em contato com o Centro de suporte técnico da HP para que um técnico o ajude por telefone. A HP especifica nos materiais fornecidos com a peça CSR de reposição se a peça com defeito deve ser devolvida à HP. Nos casos em que isso for necessário, é preciso enviar a peça com defeito à HP dentro do período determinado, normalmente cinco (5) dias úteis. A peça com defeito deve ser enviada com a documentação correspondente no material de transporte fornecido. Caso não o faça, a HP poderá cobrar a reposição. Para as peças de reparo feito pelo cliente, a HP paga todas as despesas de transporte e de devolução da peça e determina a transportadora/serviço postal a ser utilizado.

Para obter mais informações sobre o programa de reparo feito pelo cliente da HP, entre em contato com o fornecedor de serviços local. Para o programa norte-americano, visite o site da HP (<http://www.hp.com/go/selfrepair>).

Serviço de garantia apenas para peças

A garantia limitada da HP pode incluir um serviço de garantia apenas para peças. Segundo os termos do serviço de garantia apenas para peças, a HP fornece as peças de reposição sem cobrar nenhuma taxa.

No caso desse serviço, a substituição de peças CSR é obrigatória. Se desejar que a HP substitua essas peças, serão cobradas as despesas de transporte e mão-de-obra do serviço.

顧客自己修理保証サービス

修理時間を短縮し、故障部品の交換における高い柔軟性を確保するために、HP製品には多数の顧客自己修理（CSR）部品があります。診断の際に、CSR部品を使用すれば修理ができるとHP（HPまたはHP正規保守代理店）が判断した場合、HPはその部品を直接、お客様に発送し、お客様に交換していただきます。CSR部品には以下の2通りがあります。

- 必須 - 顧客自己修理が必須の部品。当該部品について、もしもお客様がHPに交換作業を依頼される場合には、その修理サービスに関する交通費および人件費がお客様に請求されます。
- 任意 - 顧客自己修理が任意である部品。この部品も顧客自己修理用です。当該部品について、もしもお客様がHPに交換作業を依頼される場合には、お買い上げの製品に適用される保証サービス内容の範囲内においては、別途費用を負担していただくことなく保証サービスを受けることができます。

注： HP製品の一部の部品は、顧客自己修理用ではありません。製品の保証を継続するためには、HPまたはHP正規保守代理店による交換作業が必須となります。部品カタログには、当該部品が顧客自己修理除外品である旨が記載されています。

部品供給が可能な場合、地域によっては、CSR部品を翌営業日に届くように発送します。また、地域によっては、追加費用を負担いただくことにより同日または4時間以内に届くように発送することも可能な場合があります。サポートが必要なときは、HPの修理受付窓口にご連絡いただければ、技術者が電話でアドバイスします。交換用のCSR部品または同梱物には、故障部品をHPに返送する必要があるかどうかが表示されています。故障部品をHPに返送する必要がある場合は、指定期限内（通常は5営業日以内）に故障部品をHPに返送してください。故障部品を返送する場合は、届いた時の梱包箱に関連書類とともに入れてください。故障部品を返送しない場合、HPから部品費用が請求されます。顧客自己修理の際には、HPは送料および部品返送費を全額負担し、使用する宅配便会社や運送会社を指定します。

部品のみ保証サービス

HP保証サービスには、部品のみ保証サービスが適用される場合があります。このサービスでは、交換部品は無償で提供されます。

部品のみ保証サービスにおいては、CSR部品をお客様により交換作業していただくことが必須となります。当該部品について、もしもお客様がHPに交換作業を依頼される場合には、その修理サービスに関する交通費および人件費はお客様の負担となります。

客户自行维修

HP 产品提供许多客户自行维修 (CSR) 部件，以尽可能缩短维修时间和在更换缺陷部件方面提供更大的灵活性。如果在诊断期间 HP（或 HP 服务提供商或服务合作伙伴）确定可以通过使用 CSR 部件完成维修，HP 将直接把该部件发送给您进行更换。有两类 CSR 部件：

- **强制性的** — 要求客户必须自行维修的部件。如果您请求 HP 更换这些部件，则必须为该服务支付差旅费和人工费用。
- **可选的** — 客户可以选择是否自行维修的部件。这些部件也是为客户自行维修设计的。不过，如果您要求 HP 为您更换这些部件，则根据为您的产品指定的保修服务类型，HP 可能收取或不再收取任何附加费用。

注：某些 HP 部件的设计并未考虑客户自行维修。为了满足客户保修的需要，HP 要求授权服务提供商更换相关部件。这些部件在部件图解目录中标记为“否”。

CSR 部件将在下一个工作日发运（取决于备货情况和允许的地理范围）。在允许的地理范围内，可在当天或四小时内发运，但要收取额外费用。如果需要帮助，您可以致电 HP 技术支持中心，将会有技术人员通过电话为您提供帮助。HP 会在随更换的 CSR 部件发运的材料中指明是否必须将有缺陷的部件返还给 HP。如果要求您将缺陷的部件返还给 HP，那么您必须在规定期限内（通常是五 (5) 个工作日）将缺陷部件发给 HP。有缺陷的部件必须随所提供的发运材料中的相关文件一起返还。如果未能送还有缺陷的部件，HP 可能会要求您支付更换费用。客户自行维修时，HP 将承担所有相关运输和部件返回费用，并指定快递商/承运商。

有关 HP 客户自行维修计划的详细信息，请与您当地的服务提供商联系。有关北美地区的计划，请访问 HP 网站 (<http://www.hp.com/go/selfrepair>)。

仅部件保修服务

您的 HP 有限保修服务可能涉及仅部件保修服务。根据仅部件保修服务条款的规定，HP 将免费提供更换的部件。

仅部件保修服务要求进行 CSR 部件更换。如果您请求 HP 更换这些部件，则必须为该服务支付差旅费和人工费用。

客戶自行維修

HP 產品設計了許多「客戶自行維修」(CSR) 的零件以減少維修時間，並且使得更換瑕疵零件時能有更大的彈性。如果在診斷期間 HP（或 HP 服務供應商或維修夥伴）辨認出此項維修工作可以藉由使用 CSR 零件來完成，則 HP 將直接寄送該零件給您作更換。CSR 零件分為兩種類別：

- **強制的** — 客戶自行維修所使用的零件是強制性的。如果您要求 HP 更換這些零件，HP 將會向您收取此服務所需的外出費用與勞動成本。
- **選購的** — 客戶自行維修所使用的零件是選購的。這些零件也設計用於客戶自行維修之用。不過，如果您要求 HP 為您更換，則可能需要也可能不需要負擔額外的費用，端視針對此產品指定的保固服務類型而定。

備註：某些 HP 零件沒有消費者可自行維修的設計。為符合客戶保固，HP 需要授權的服務供應商更換零件。這些零件在圖示的零件目錄中，被標示為「否」。

基於材料取得及環境允許的情況下，CSR 零件將於下一個工作日以快遞寄送。在環境的允許下當天或四小時內送達，則可能需要額外的費用。若您需要協助，可致電「HP 技術支援中心」，會有一位技術人員透過電話來協助您。不論損壞的零件是否必須退回，HP 皆會在與 CSR 替換零件一起運送的材料中註明。若要將損壞的零件退回 HP，您必須在指定的一段時間內（通常為五 (5) 個工作天），將損壞的零件寄回 HP。損壞的零件必須與寄送資料中隨附的相關技術文件一併退還。如果無法退還損壞的零件，HP 可能要向您收取替換費用。針對客戶自行維修情形，HP 將負責所有運費及零件退還費用並指定使用何家快遞/貨運公司。

如需 HP 的「客戶自行維修」方案詳細資訊，請連絡您當地的服務供應商。至於北美方案，請參閱 HP 網站 (<http://www.hp.com/go/selfrepair>)。

僅限零件的保固服務

您的「HP 有限保固」可能包含僅限零件的保固服務。在僅限零件的保固服務情況下，HP 將免費提供替換零件。

針對僅限零件的保固服務，CSR 零件替換是強制性的。如果您要求 HP 更換這些零件，HP 將會向您收取此服務所需的外出費用與勞動成本。

고객 셀프 수리

HP 제품은 수리 시간을 최소화하고 결함이 있는 부품 교체 시 더욱 융통성을 발휘할 수 있도록 하기 위해 고객 셀프 수리(CSR) 부품을 다량 사용하여 설계되었습니다. 진단 기간 동안 HP(또는 HP 서비스 공급업체 또는 서비스 협력업체)에서 CSR 부품을 사용하여 수리가 가능하다고 판단되면 HP는 해당 부품을 바로 사용자에게 보내어 사용자가 교체할 수 있도록 합니다. CSR 부품에는 두 가지 종류가 있습니다.

- **고객 셀프 수리가 의무 사항인 필수 부품.** 사용자가 HP에 이 부품의 교체를 요청할 경우 이 서비스에 대한 출장비 및 작업비가 청구됩니다.
- **고객 셀프 수리가 선택 사항인 부품.** 이 부품들도 고객 셀프 수리가 가능하도록 설계되었습니다. 하지만 사용자가 HP에 이 부품의 교체를 요청할 경우 사용자가 구입한 제품에 해당하는 보증 서비스 유형에 따라 추가 비용 없이 교체가 가능할 수 있습니다.

참고: 일부 HP 부품은 고객 셀프 수리가 불가능하도록 설계되었습니다. HP는 만족스러운 고객 보증을 위해 공인 서비스 제공업체를 통해 부품을 교체하도록 하고 있습니다. 이러한 부품들은 Illustrated Parts Catalog에 "No"라고 표시되어 있습니다.

CSR 부품은 재고 상태와 지리적 조건이 허용하는 경우 다음 영업일 납품이 가능하도록 배송이 이루어집니다. 지리적 조건이 허용하는 경우 추가 비용이 청구되는 조건으로 당일 또는 4시간 배송이 가능할 수도 있습니다. 도움이 필요하시면 HP 기술 지원 센터로 전화하십시오. 전문 기술자가 전화로 도움을 줄 것입니다. HP는 결함이 발생한 부품을 HP로 반환해야 하는지 여부를 CSR 교체 부품과 함께 배송된 자료에 지정합니다. 결함이 발생한 부품을 HP로 반환해야 하는 경우에는 지정된 기간 내(통상 영업일 기준 5일)에 HP로 반환해야 합니다. 이 때 결함이 발생한 부품은 제공된 포장 재료에 넣어 관련 설명서와 함께 반환해야 합니다. 결함이 발생한 부품을 반환하지 않는 경우 HP가 교체 부품에 대해 비용을 청구할 수 있습니다. 고객 셀프 수리의 경우, HP는 모든 운송 및 부품 반환 비용을 부담하며 이용할 운송업체 및 택배 서비스를 결정합니다.

HP 고객 셀프 수리 프로그램에 대한 자세한 내용은 가까운 서비스 제공업체에 문의하십시오. 북미 지역의 프로그램에 대해서는 HP 웹 사이트(<http://www.hp.com/go/selfrepair>)를 참조하십시오.

부품 제공 보증 서비스

HP 제한 보증에는 부품 제공 보증 서비스가 포함될 수 있습니다. 이러한 경우 HP는 부품 제공 보증 서비스의 조건에 따라 교체 부품만을 무료로 제공합니다.

부품 제공 보증 서비스 제공 시 CSR 부품 교체는 의무 사항입니다. 사용자가 HP에 이 부품의 교체를 요청할 경우 이 서비스에 대한 출장비 및 작업비가 청구됩니다.

Illustrated parts catalog

Mechanical components

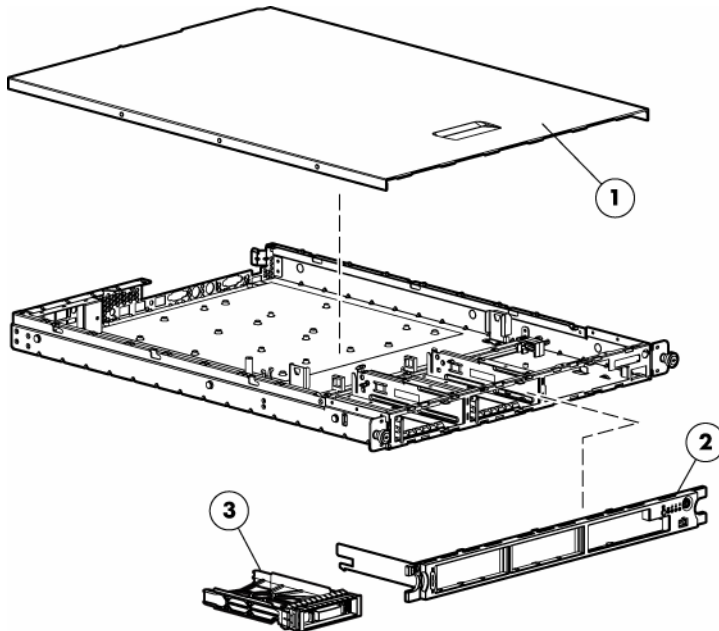

Item	Description	Spare part number	Customer self repair (on page 5)
1	Access panel	432934-001	Mandatory ¹
2	Front bezel	432935-001	Mandatory ¹
3	Hard drive blank	413960-001	Mandatory ¹

¹Mandatory—Parts for which customer self repair is mandatory. If you request HP to replace these parts, you will be charged for the travel and labor costs of this service.

²Optional—Parts for which customer self repair is optional. These parts are also designed for customer self repair. If, however, you require that HP replace them for you, there may or may not be additional charges, depending on the type of warranty service designated for your product.

³No—Some HP parts are not designed for customer self repair. In order to satisfy the customer warranty, HP requires that an authorized service provider replace the part. These parts are identified as "No" in the Illustrated Parts Catalog.

¹Mandatory: Obligatoire—Pièces pour lesquelles la réparation par le client est obligatoire. Si vous demandez à HP de remplacer ces pièces, les coûts de déplacement et main d'œuvre du service vous seront facturés.

²Optional: Facultatif—Pièces pour lesquelles la réparation par le client est facultative. Ces pièces sont également conçues pour permettre au client d'effectuer lui-même la réparation. Toutefois, si vous demandez à HP de remplacer ces pièces, l'intervention peut ou non vous être facturée, selon le type de garantie applicable à votre produit.

³No: Non—Certaines pièces HP ne sont pas conçues pour permettre au client d'effectuer lui-même la réparation. Pour que la garantie puisse s'appliquer, HP exige que le remplacement de la pièce soit effectué par un Mainteneur Agréé. Ces pièces sont identifiées par la mention "Non" dans le Catalogue illustré.

¹Mandatory: Obbligatorie—Parti che devono essere necessariamente riparate dal cliente. Se il cliente ne affida la riparazione ad HP, deve sostenere le spese di spedizione e di manodopera per il servizio.

²Optional: Opzionali—Parti la cui riparazione da parte del cliente è facoltativa. Si tratta comunque di componenti progettati per questo scopo. Se tuttavia il cliente ne richiede la sostituzione ad HP, potrebbe dover sostenere spese aggiuntive a seconda del tipo di garanzia previsto per il prodotto.

³No: Non CSR—Alcuni componenti HP non sono progettati per la riparazione da parte del cliente. Per rispettare la garanzia, HP richiede che queste parti siano sostituite da un centro di assistenza autorizzato. Tali parti sono identificate da un "No" nel Catalogo illustrato dei componenti.

¹Mandatory: Zwingend—Teile, die im Rahmen des Customer Self Repair Programms ersetzt werden müssen. Wenn Sie diese Teile von HP ersetzen lassen, werden Ihnen die Versand- und Arbeitskosten für diesen Service berechnet.

²Optional: Optional—Teile, für die das Customer Self Repair-Verfahren optional ist. Diese Teile sind auch für Customer Self Repair ausgelegt. Wenn Sie jedoch den Austausch dieser Teile von HP vornehmen lassen möchten, können bei diesem Service je nach den für Ihr Produkt vorgesehenen Garantiebedingungen zusätzliche Kosten anfallen.

³No: Kein—Einige Teile sind nicht für Customer Self Repair ausgelegt. Um den Garantieanspruch des Kunden zu erfüllen, muss das Teil von einem HP Servicepartner ersetzt werden. Im illustrierten Teilekatalog sind diese Teile mit „No“ bzw. „Nein“ gekennzeichnet.

¹Mandatory: Obligatorio—componentes para los que la reparación por parte del usuario es obligatoria. Si solicita a HP que realice la sustitución de estos componentes, tendrá que hacerse cargo de los gastos de desplazamiento y de mano de obra de dicho servicio.

²Optional: Opcional— componentes para los que la reparación por parte del usuario es opcional. Estos componentes también están diseñados para que puedan ser reparados por el usuario. Sin embargo, si precisa que HP realice su sustitución, puede o no conllevar costes adicionales, dependiendo del tipo de servicio de garantía correspondiente al producto.

³No: No—Algunos componentes no están diseñados para que puedan ser reparados por el usuario. Para que el usuario haga valer su garantía, HP pone como condición que un proveedor de servicios autorizado realice la sustitución de estos componentes. Dichos componentes se identifican con la palabra "No" en el catálogo ilustrado de componentes.

¹Mandatory: Verplicht—Onderdelen waarvoor Customer Self Repair verplicht is. Als u HP verzoekt deze onderdelen te vervangen, komen de reiskosten en het arbeidsloon voor uw rekening.

²Optional: Optioneel—Onderdelen waarvoor reparatie door de klant optioneel is. Ook deze onderdelen zijn ontworpen voor reparatie door de klant. Als u echter HP verzoekt deze onderdelen voor u te vervangen, kunnen daarvoor extra kosten in rekening worden gebracht, afhankelijk van het type garantieservice voor het product.

³No: Nee—Sommige HP onderdelen zijn niet ontwikkeld voor reparatie door de klant. In verband met de garantievoorwaarden moet het onderdeel door een geautoriseerde Service Partner worden vervangen. Deze onderdelen worden in de geïllustreerde onderdelencatalogus aangemerkt met "Nee".

¹Mandatory: Obrigatória—Peças cujo reparo feito pelo cliente é obrigatório. Se desejar que a HP substitua essas peças, serão cobradas as despesas de transporte e mão-de-obra do serviço.

²Optional: Opcional—Peças cujo reparo feito pelo cliente é opcional. Essas peças também são projetadas para o reparo feito pelo cliente. No entanto, se desejar que a HP as substitua, pode haver ou não a cobrança de taxa adicional, dependendo do tipo de serviço de garantia destinado ao produto.

³No: Nenhuma—Algumas peças da HP não são projetadas para o reparo feito pelo cliente. A fim de cumprir a garantia do cliente, a HP exige que um técnico autorizado substitua a peça. Essas peças estão identificadas com a marca "No" (Não), no catálogo de peças ilustrado.

¹Mandatory: 必須・顧客自己修理が必須の部品。当該部品について、もしもお客様がHPに交換作業を依頼される場合には、その修理サービスに関する交通費および人件費がお客様に請求されます。

²Optional: 任意・顧客自己修理が任意である部品。この部品も顧客自己修理用です。当該部品について、もしもお客様がHPに交換作業を依頼される場合には、お買い上げの製品に適用される保証サービス内容の範囲内においては、費用を負担していただくことなく保証サービスを受けることができます。

³No: 除外・HP製品の一部の部品は、顧客自己修理用ではありません。製品の保証を継続するためには、HPまたはHP正規保守代理店による交換作業が必須となります。部品カタログには、当該部品が顧客自己修理除外品である旨が記載されています。

¹Mandatory: 强制性的 — 要求客户必须自行维修的部件。如果您请求 HP 更换这些部件，则必须为该服务支付差旅费和人工费用。

²Optional: 可选的 — 客户可以选择是否自行维修的部件。这些部件也是为客户自行维修设计的。不过，如果您要求 HP 为您更换这些部件，则根据为您的产品指定的保修服务类型，HP 可能收取或不再收取任何附加费用。

³No: 否 — 某些 HP 部件的设计并未考虑客户自行维修。为了满足客户保修的需要，HP 要求授权服务提供商更换相关部件。这些部件在部件图解目录中标记为“否”。

¹Mandatory: 强制的 — 客户自行维修所使用的零件是强制性的。如果您要求 HP 更换这些零件，HP 将会向您收取此服务所需的外出费用与劳动成本。

²Optional: 選購的 — 客户自行维修所使用的零件是選購的。這些零件也設計用於客戶自行維修之用。不過，如果您要求 HP 為您更換，則可能需要也可能不需要負擔額外的費用，端視針對此產品指定的保固服務類型而定。

³No: 否 — 某些 HP 零件沒有消費者可自行維修的設計。為符合客戶保固，HP 需要授權的服務供應商更換零件。這些零件在圖示的零件目錄中，被標示為「否」。

¹ Mandatory: 필수 — 고객 셀프 수리가 의무 사항인 필수 부품. 사용자가 HP에 이 부품의 교체를 요청할 경우 이 서비스에 대한 출장비 및 작업비가 청구됩니다.

² Optional: 옵션 — 고객 셀프 수리가 선택 사항인 부품. 이 부품들도 고객 셀프 수리가 가능하도록 설계되었습니다. 하지만 사용자가 HP에 이 부품의 교체를 요청할 경우 사용자가 구입한 제품에 해당하는 보증 서비스 유형에 따라 추가 비용 없이 교체가 가능할 수 있습니다.

³ No: No — 고객 셀프 수리가 불가능하도록 설계된 HP 부품. 이 부품들은 고객 셀프 수리가 불가능하도록 설계되었습니다. HP는 고객 보증을 만족시키기 위해 공인 서비스 제공업체를 통해 부품을 교체하도록 하고 있습니다.

System components

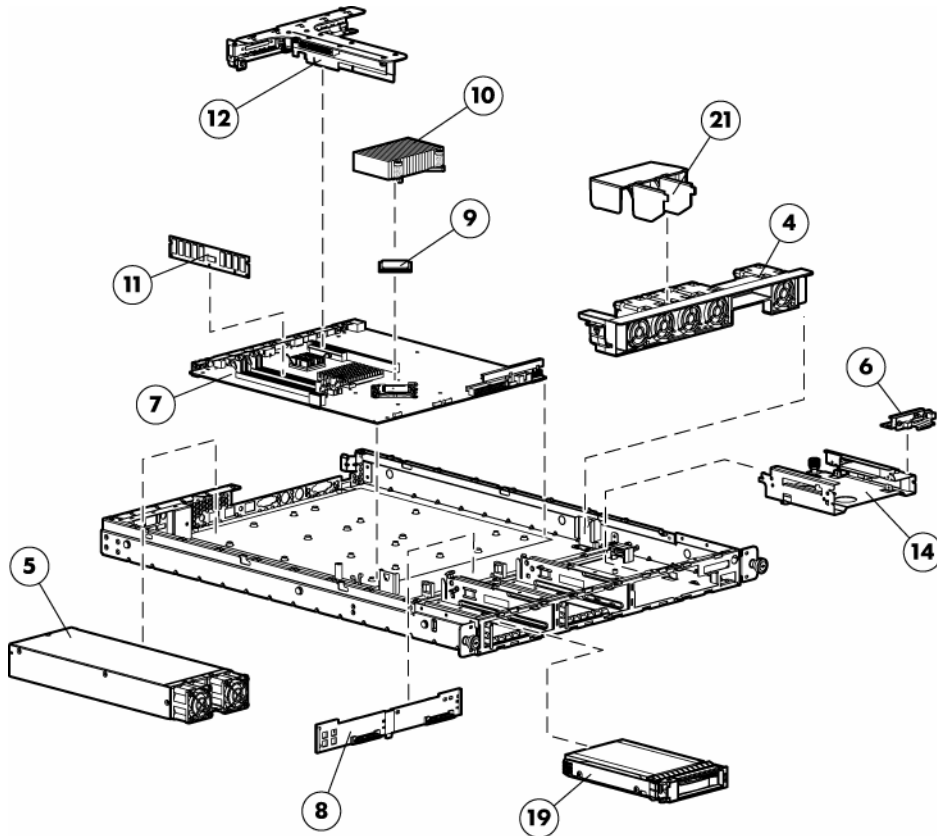

Item	Description	Spare part number	Customer self repair (on page 5)
	System components		
4	Fan assembly	432933-001	Optional ²
5	Power supply, 420-W	432932-001	Optional ²
	Boards		
6	Power button/LED board	432931-001	Optional ²
7	System board	432924-001	Optional ²
8	SAS/SATA backplane	432926-001	Optional ²
9	Processors	—	—
	a) 3.2-GHz Intel® Celeron® D 352 processor, 512-KB L2 cache, 533-MHz FSB	418779-001	Optional ²
	b) 1.86-GHz Intel® Xeon™ processor 3040, dual-core, 2-MB cache, 1066-MHz FSB*	436522-001	Optional ²
	c) 2.13-GHz Intel® Xeon™ processor 3050, dual-core, 2-MB cache, 1066-MHz FSB*	436523-001	Optional ²
	d) 2.4-GHz Intel® Xeon™ processor 3060, dual-core, 4-MB cache, 1066-MHz FSB*	432943-001	Optional ²
	e) 2.8-GHz Intel® Pentium® D 820 processor, dual-core, 2 × 1-MB cache, 800-MHz FSB*	436421-001	Optional ²

Item	Description	Spare part number	Customer self repair (on page 5)
	f) 3.4-GHz Intel® Pentium® 4 651 processor, 2-MB cache, 800-MHz FSB*	418787-001	Optional ²
10	Heatsink	432929-001	Optional ²
11	Memory	—	—
	a) 512-MB, PC2-5300 DDR ECC Unbuffered DIMM	433555-001	Mandatory ¹
	b) 1-GB, PC2-5300 DDR ECC Unbuffered DIMM*	432930-001	Mandatory ¹
	c) 2-GB, PC2-5300 DDR ECC Unbuffered DIMM*	433935-001	Mandatory ¹
12	PCI riser board assembly with PCIe riser boards and bracket	432936-001	Optional ²
13	PCI-X riser board*	409451-001	Optional ²
	Mass storage devices		
14	Media cage	—	—
15	CD-ROM drive*	390629-001	Optional ²
16	DVD-ROM drive*	383981-001	Optional ²
17	DVD-RW drive*	398663-001	Optional ²
18	Diskette drive*	390530-001	Optional ²
19	SATA hard drives	—	—
	a) 80-GB	397551-001	Mandatory ¹
	b) 160-GB*	397552-001	Mandatory ¹
	c) 250-GB*	397553-001	Mandatory ¹
	d) 500-GB*	395501-001	Mandatory ¹
	e) 750-GB*	432401-001	Mandatory ¹
20	SAS hard drives*	—	—
	a) 36-GB	376593-001	Mandatory ¹
	b) 72-GB	376594-001	Mandatory ¹
	c) 146-GB	376595-001	Mandatory ¹
	Miscellaneous		
21	Miscellaneous plastics kit*	378632-001	Mandatory ¹
	a) Air baffle	—	—
	b) PCI card guide*	—	—
	c) Bezel screws, T-15*	—	—
	d) Serial label pull tab*	—	—
22	Power cord*	378675-001	Mandatory ¹
23	Battery, 3-V lithium*	234556-001	Optional ²
24	Hard drive cable*	432927-001	Optional ²

Item	Description	Spare part number	Customer self repair (on page 5)
25	Optical drive cable*	433137-001	Optional ²
26	Diskette drive cable*	433138-001	Optional ²
27	USB cable*	432938-001	Optional ²
28	Cable management arm kit*	360105-001	Mandatory ¹
29	Rack-mounting hardware kit*	360104-001	Mandatory ¹

*Not shown

¹Mandatory—Parts for which customer self repair is mandatory. If you request HP to replace these parts, you will be charged for the travel and labor costs of this service.

²Optional—Parts for which customer self repair is optional. These parts are also designed for customer self repair. If, however, you require that HP replace them for you, there may or may not be additional charges, depending on the type of warranty service designated for your product.

³No—Some HP parts are not designed for customer self repair. In order to satisfy the customer warranty, HP requires that an authorized service provider replace the part. These parts are identified as "No" in the Illustrated Parts Catalog.

¹Mandatory: Obligatoire—Pièces pour lesquelles la réparation par le client est obligatoire. Si vous demandez à HP de remplacer ces pièces, les coûts de déplacement et main d'œuvre du service vous seront facturés.

²Optional: Facultatif—Pièces pour lesquelles la réparation par le client est facultative. Ces pièces sont également conçues pour permettre au client d'effectuer lui-même la réparation. Toutefois, si vous demandez à HP de remplacer ces pièces, l'intervention peut ou non vous être facturée, selon le type de garantie applicable à votre produit.

³No: Non—Certaines pièces HP ne sont pas conçues pour permettre au client d'effectuer lui-même la réparation. Pour que la garantie puisse s'appliquer, HP exige que le remplacement de la pièce soit effectué par un Mainteneur Agréé. Ces pièces sont identifiées par la mention "Non" dans le Catalogue illustré.

¹Mandatory: Obbligatorie—Parti che devono essere necessariamente riparate dal cliente. Se il cliente ne affida la riparazione ad HP, deve sostenere le spese di spedizione e di manodopera per il servizio.

²Optional: Opzionali—Parti la cui riparazione da parte del cliente è facoltativa. Si tratta comunque di componenti progettati per questo scopo. Se tuttavia il cliente ne richiede la sostituzione ad HP, potrebbe dover sostenere spese addizionali a seconda del tipo di garanzia previsto per il prodotto.

³No: Non CSR—Alcuni componenti HP non sono progettati per la riparazione da parte del cliente. Per rispettare la garanzia, HP richiede che queste parti siano sostituite da un centro di assistenza autorizzato. Tali parti sono identificate da un "No" nel Catalogo illustrato dei componenti.

¹Mandatory: Zwingend—Teile, die im Rahmen des Customer Self Repair Programms ersetzt werden müssen. Wenn Sie diese Teile von HP ersetzen lassen, werden Ihnen die Versand- und Arbeitskosten für diesen Service berechnet.

²Optional: Optional—Teile, für die das Customer Self Repair-Verfahren optional ist. Diese Teile sind auch für Customer Self Repair ausgelegt. Wenn Sie jedoch den Austausch dieser Teile von HP vornehmen lassen möchten, können bei diesem Service je nach den für Ihr Produkt vorgesehenen Garantiebedingungen zusätzliche Kosten anfallen.

³No: Kein—Einige Teile sind nicht für Customer Self Repair ausgelegt. Um den Garantieanspruch des Kunden zu erfüllen, muss das Teil von einem HP Servicepartner ersetzt werden. Im illustrierten Teilekatalog sind diese Teile mit „No“ bzw. „Nein“ gekennzeichnet.

¹Mandatory: Obligatorio—componentes para los que la reparación por parte del usuario es obligatoria. Si solicita a HP que realice la sustitución de estos componentes, tendrá que hacerse cargo de los gastos de desplazamiento y de mano de obra de dicho servicio.

²Optional: Opcional— componentes para los que la reparación por parte del usuario es opcional. Estos componentes también están diseñados para que puedan ser reparados por el usuario. Sin embargo, si precisa que HP realice su sustitución, puede o no conllevar costes adicionales, dependiendo del tipo de servicio de garantía correspondiente al producto.

³No: No—Algunos componentes no están diseñados para que puedan ser reparados por el usuario. Para que el usuario haga valer su garantía, HP pone como condición que un proveedor de servicios autorizado realice la sustitución de estos componentes. Dichos componentes se identifican con la palabra “No” en el catálogo ilustrado de componentes.

¹Mandatory: Verplicht—Onderdelen waarvoor Customer Self Repair verplicht is. Als u HP verzoekt deze onderdelen te vervangen, komen de reiskosten en het arbeidsloon voor uw rekening.

²Optional: Optioneel—Onderdelen waarvoor reparatie door de klant optioneel is. Ook deze onderdelen zijn ontworpen voor reparatie door de klant. Als u echter HP verzoekt deze onderdelen voor u te vervangen, kunnen daarvoor extra kosten in rekening worden gebracht, afhankelijk van het type garantieservice voor het product.

³No: Nee—Sommige HP onderdelen zijn niet ontwikkeld voor reparatie door de klant. In verband met de garantiev voorwaarden moet het onderdeel door een geautoriseerde Service Partner worden vervangen. Deze onderdelen worden in de geïllustreerde onderdelencatalogus aangemerkt met "Nee".

¹Mandatory: Obrigatória—Peças cujo reparo feito pelo cliente é obrigatório. Se desejar que a HP substitua essas peças, serão cobradas as despesas de transporte e mão-de-obra do serviço.

²Optional: Opcional—Peças cujo reparo feito pelo cliente é opcional. Essas peças também são projetadas para o reparo feito pelo cliente. No entanto, se desejar que a HP as substitua, pode haver ou não a cobrança de taxa adicional, dependendo do tipo de serviço de garantia destinado ao produto.

³No: Nenhuma—Algumas peças da HP não são projetadas para o reparo feito pelo cliente. A fim de cumprir a garantia do cliente, a HP exige que um técnico autorizado substitua a peça. Essas peças estão identificadas com a marca “No” (Não), no catálogo de peças ilustrado.

¹Mandatory : 必須 - 顧客自己修理が必須の部品。当該部品について、もしもお客様がHPに交換作業を依頼される場合には、その修理サービスに関する交通費および人件費がお客様に請求されます。

²Optional : 任意 - 顧客自己修理が任意である部品。この部品も顧客自己修理用です。当該部品について、もしもお客様がHPに交換作業を依頼される場合には、お買い上げの製品に適用される保証サービス内容の範囲内においては、費用を負担していただくことなく保証サービスを受けることができます。

³No : 除外 - HP製品の一部の部品は、顧客自己修理用ではありません。製品の保証を継続するためには、HPまたはHP正規保守代理店による交換作業が必須となります。部品カタログには、当該部品が顧客自己修理除外品である旨が記載されています。

¹Mandatory: 强制性的 — 要求客户必须自行维修的部件。如果您请求 HP 更换这些部件，则必须为该服务支付差旅费和人工费用。

²Optional: 可选的 — 客户可以选择是否自行维修的部件。这些部件也是为客户自行维修设计的。不过，如果您要求 HP 为您更换这些部件，则根据为您的产品指定的保修服务类型，HP 可能收取或不再收取任何附加费用。

³No: 否 — 某些 HP 部件的设计并未考虑客户自行维修。为了满足客户保修的需要，HP 要求授权服务提供商更换相关部件。这些部件在部件图解目录中标记为“否”。

¹Mandatory: 强制的 — 客户自行维修所使用的零件是强制性的。如果您要求 HP 更换这些零件，HP 将会向您收取此服务所需的外出费用与劳动成本。

²Optional: 選購的 — 客户自行维修所使用的零件是選購的。這些零件也設計用於客戶自行維修之用。不過，如果您要求 HP 為您更換，則可能需要也可能不需要負擔額外的費用，端視針對此產品指定的保固服務類型而定。

³No: 否 — 某些 HP 零件沒有消費者可自行維修的設計。為符合客戶保固，HP 需要授權的服務供應商更換零件。這些零件在圖示的零件目錄中，被標示為「否」。

¹ Mandatory: 필수 — 고객 셀프 수리가 의무 사항인 필수 부품. 사용자가 HP에 이 부품의 교체를 요청할 경우 이 서비스에 대한 출장비 및 작업비가 청구됩니다.

² Optional: 옵션 — 고객 셀프 수리가 선택 사항인 부품. 이 부품들도 고객 셀프 수리가 가능하도록 설계되었습니다. 하지만 사용자가 HP에 이 부품의 교체를 요청할 경우 사용자가 구입한 제품에 해당하는 보증 서비스 유형에 따라 추가 비용 없이 교체가 가능할 수 있습니다.

³ No: No — 고객 셀프 수리가 불가능하도록 설계된 HP 부품. 이 부품들은 고객 셀프 수리가 불가능하도록 설계되었습니다. HP는 고객 보증을 만족시키기 위해 공인 서비스 제공업체를 통해 부품을 교체하도록 하고 있습니다.

Removal and replacement procedures

Required tools

You need the following items for some procedures:

- T-10/T-15 Torx screwdriver (included with the server)
- HP Insight Diagnostics software ("[HP Insight Diagnostics](#)" on page 62)

Safety considerations

Before performing service procedures, review all the safety information.

Preventing electrostatic discharge

To prevent damaging the system, be aware of the precautions you need to follow when setting up the system or handling parts. A discharge of static electricity from a finger or other conductor may damage system boards or other static-sensitive devices. This type of damage may reduce the life expectancy of the device.

To prevent electrostatic damage:

- Avoid hand contact by transporting and storing products in static-safe containers.
- Keep electrostatic-sensitive parts in their containers until they arrive at static-free workstations.
- Place parts on a grounded surface before removing them from their containers.
- Avoid touching pins, leads, or circuitry.
- Always be properly grounded when touching a static-sensitive component or assembly.

Symbols on equipment

The following symbols may be placed on equipment to indicate the presence of potentially hazardous conditions.



This symbol indicates the presence of hazardous energy circuits or electric shock hazards. Refer all servicing to qualified personnel.

WARNING: To reduce the risk of injury from electric shock hazards, do not open this enclosure. Refer all maintenance, upgrades, and servicing to qualified personnel.



This symbol indicates the presence of electric shock hazards. The area contains no user or field serviceable parts. Do not open for any reason.

WARNING: To reduce the risk of injury from electric shock hazards, do not open this enclosure.



This symbol on an RJ-45 receptacle indicates a network interface connection.

WARNING: To reduce the risk of electric shock, fire, or damage to the equipment, do not plug telephone or telecommunications connectors into this receptacle.



This symbol indicates the presence of a hot surface or hot component. If this surface is contacted, the potential for injury exists.

WARNING: To reduce the risk of injury from a hot component, allow the surface to cool before touching.



12.27 kg
27.00

This symbol indicates that the component exceeds the recommended weight for one individual to handle safely.

WARNING: To reduce the risk of personal injury or damage to the equipment, observe local occupational health and safety requirements and guidelines for manual material handling.



These symbols, on power supplies or systems, indicate that the equipment is supplied by multiple sources of power.

WARNING: To reduce the risk of injury from electric shock, remove all power cords to completely disconnect power from the system.

Rack warnings



WARNING: To reduce the risk of personal injury or damage to the equipment, be sure that:

- The leveling jacks are extended to the floor.
- The full weight of the rack rests on the leveling jacks.
- The stabilizing feet are attached to the rack if it is a single-rack installation.
- The racks are coupled together in multiple-rack installations.
- Only one component is extended at a time. A rack may become unstable if more than one component is extended for any reason.



WARNING: To reduce the risk of personal injury or equipment damage when unloading a rack:

- At least two people are needed to safely unload the rack from the pallet. An empty 42U rack can weigh as much as 115 kg (253 lb), can stand more than 2.1 m (7 ft) tall, and may become unstable when being moved on its casters.
- Never stand in front of the rack when it is rolling down the ramp from the pallet. Always handle the rack from both sides.



WARNING: To reduce the risk of personal injury or damage to the equipment, adequately stabilize the rack before extending a component outside the rack. Extend only one component at a time. A rack may become unstable if more than one component is extended.



WARNING: When installing a server in a telco rack, be sure that the rack frame is adequately secured at the top and bottom to the building structure.

Server warnings and cautions

Before installing a server, be sure that you understand the following warnings and cautions.



WARNING: To reduce the risk of electric shock or damage to the equipment:

- Do not disable the power cord grounding plug. The grounding plug is an important safety feature.
 - Plug the power cord into a grounded (earthed) electrical outlet that is easily accessible at all times.
 - Unplug the power cord from the power supply to disconnect power to the equipment.
 - Do not route the power cord where it can be walked on or pinched by items placed against it. Pay particular attention to the plug, electrical outlet, and the point where the cord extends from the server.
-



WARNING: To reduce the risk of personal injury from hot surfaces, allow the drives and the internal system components to cool before touching them.



CAUTION: Do not operate the server for long periods with the access panel open or removed. Operating the server in this manner results in improper airflow and improper cooling that can lead to thermal damage.

Preparation procedures

To access some components and perform certain service procedures, you must perform one or more of the following procedures:

- Extend the server from the rack, if applicable ("[Extend the server from the rack](#)" on page 25).
If you are performing service procedures in an HP, Compaq branded, telco, or third-party rack cabinet, you can use the locking feature of the rack rails to support the server and gain access to internal components.
For more information about telco rack solutions, refer to the RackSolutions.com website (<http://www.racksolutions.com/hp>).
- Power down the server (on page 26).
If you must remove a server from a rack or a non-hot-plug component from a server, power down the server.
- Remove the server from the rack (on page 26).
If the rack environment, cabling configuration, or the server location in the rack creates awkward conditions, remove the server from the rack.

Extend the server from the rack

NOTE: If the optional cable management arm option is installed, you can extend the server without powering down the server or disconnecting peripheral cables and power cords. These steps are only necessary with the standard cable management solution.

1. Power down the server (on page 26).

2. Disconnect all peripheral cables and power cords from the server rear panel.
3. Loosen the thumbscrews that secure the server faceplate to the front of the rack.
4. Extend the server on the rack rails until the server rail-release latches engage.



WARNING: To reduce the risk of personal injury or equipment damage, be sure that the rack is adequately stabilized before extending a component from the rack.



WARNING: To reduce the risk of personal injury, be careful when pressing the server rail-release latches and sliding the server into the rack. The sliding rails could pinch your fingers.

5. After performing the installation or maintenance procedure:
 - a. Slide the server fully into the rack.
 - b. Secure the server by tightening the thumbscrews.
6. Connect all peripheral cables and power cords.

Power down the server



WARNING: To reduce the risk of personal injury, electric shock, or damage to the equipment, remove the power cord to remove power from the server. The front panel Power On/Standby button does not completely shut off system power. Portions of the power supply and some internal circuitry remain active until AC power is removed.



IMPORTANT: If installing a hot-plug device, it is not necessary to power down the server.

1. Back up the server data.
2. Shut down the operating system as directed by the operating system documentation.
3. If the server is installed in a rack, press the UID LED button on the front panel. Blue LEDs illuminate on the front and rear panels of the server.
4. Press the Power On/Standby button to place the server in standby mode. When the server activates standby power mode, the system power LED changes to amber.
5. If the server is installed in a rack, locate the server by identifying the illuminated rear UID LED button.
6. Disconnect the power cords.

The system is now without power.

Remove the server from the rack

To remove the server from an HP, Compaq branded, telco, or third-party rack:

1. Power down the server (on page 26).
2. Disconnect all peripheral cables and power cords from the server rear panel.
3. Disconnect the cable management arm, if necessary. For more information, refer to the documentation that ships with the cable management arm.
4. Loosen the thumbscrews that secure the server faceplate to the front of the rack.
5. Extend the server from the rack (on page 25).

6. Disengage the server from the rack. For more information, refer to the documentation that ships with the rack mounting option.
7. Place the server on a sturdy, level surface.

Access panel

⚠ WARNING: To reduce the risk of personal injury from hot surfaces, allow the drives and the internal system components to cool before touching them.

⚠ CAUTION: To prevent damage to electrical components, properly ground the server before beginning any installation procedure. Improper grounding can cause ESD.

1. Identify the proper server in the server blade enclosure.
2. Back up all server data.
3. Power down the server (on page 26).
4. Remove the server ("[Remove the server from the rack](#)" on page 26).
5. Loosen the thumbscrew on the rear of the access panel.
6. Press down on the thumb indentations, slide the access panel toward the rear of the unit about 1.25 cm (0.5 in), and lift to remove the panel.

Hard drives

To remove the component:

1. Back up all data on the hard drive.
2. Power down the server (on page 26).
3. Remove the hard drive.

⚠ CAUTION: To prevent improper cooling and thermal damage, do not operate the server unless all bays are populated with either a component or a blank.

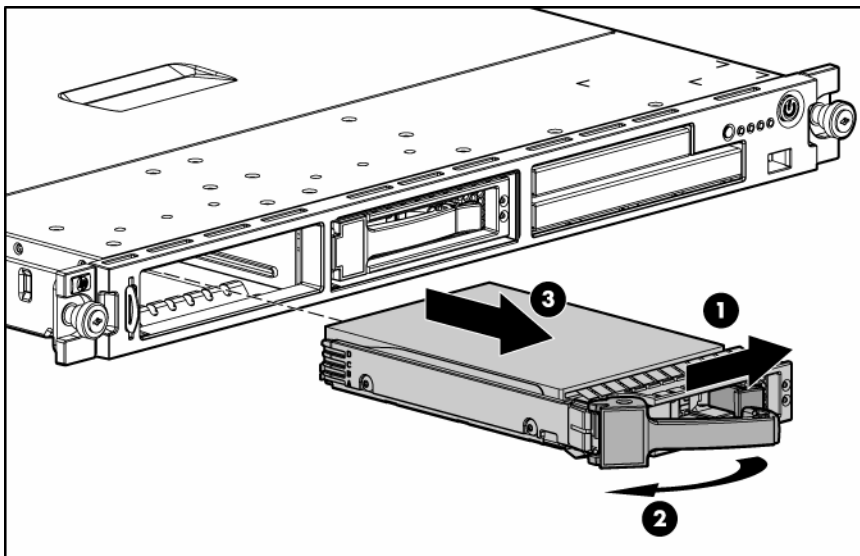

To replace the component, reverse the removal procedure.

When adding hard drives to the server, observe the following general guidelines:

- The system automatically sets all drive numbers.
- If only one hard drive is used, install it in the bay with the lowest drive number.
- Drives must be the same capacity to provide the greatest storage space efficiency when drives are grouped together into the same drive array.

Optional storage controllers provide support for hot-plug capability and drive LEDs. Controller options are:

- The embedded controller supports non-hot-plug SATA hard drives. Drive LEDs are not supported.
- Optional SATA controllers support hot-plug SATA hard drives and drive LEDs.
- Optional SAS controllers support hot-plug SAS or SATA hard drives and drive LEDs.

NOTE: ACU does not support mixing SAS and SATA drives in the same logical volume.

Hard drive blanks

Remove the component as indicated.

- △ **CAUTION:** To prevent improper cooling and thermal damage, do not operate the server unless all bays are populated with either a component or a blank.
-

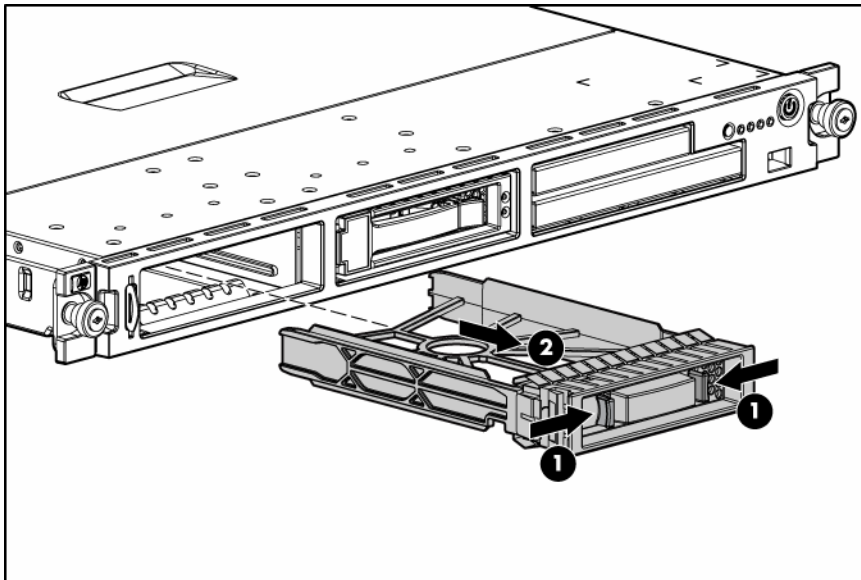

To replace the component, reverse the removal procedure.

SAS/SATA backplane

To remove the component:

1. Power down the server (on page 26).

2. Extend the server from the rack (on page 25).
3. Remove the access panel ("Access panel" on page 27).
4. Disconnect all cables connected to the SAS/SATA backplane.

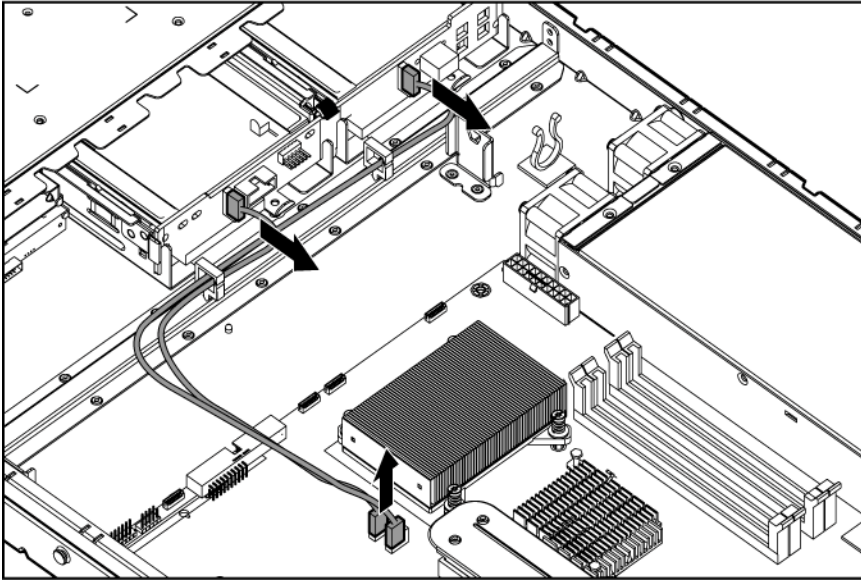

5. Remove all hard drives ("Hard drives" on page 27).
6. Remove all hard drive blanks ("Hard drive blanks" on page 28).
7. Remove the SAS/SATA backplane.

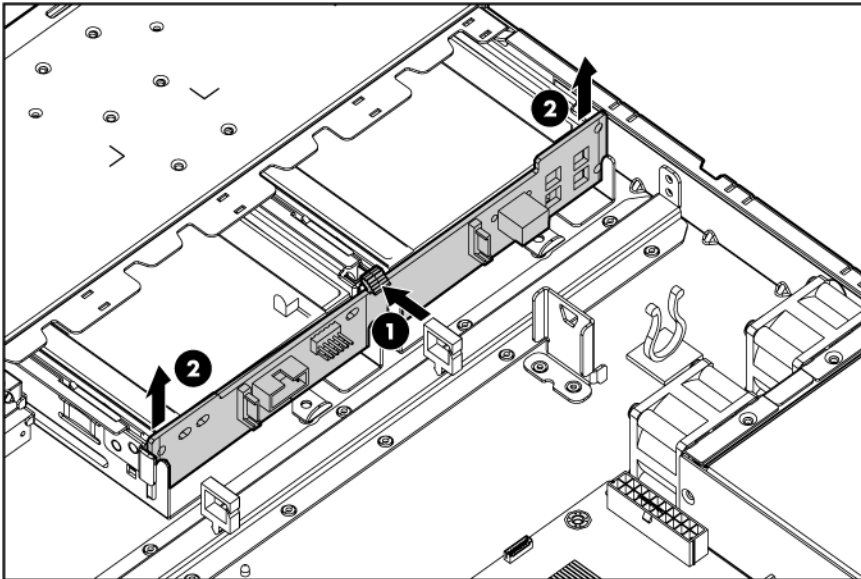

To replace the component, reverse the removal procedure.

Air baffle

To install the component:

1. Power down the server (on page 26).
2. Extend the server from the rack (on page 25).

3. Remove the access panel ("Access panel" on page 27).
4. Remove the air baffle.

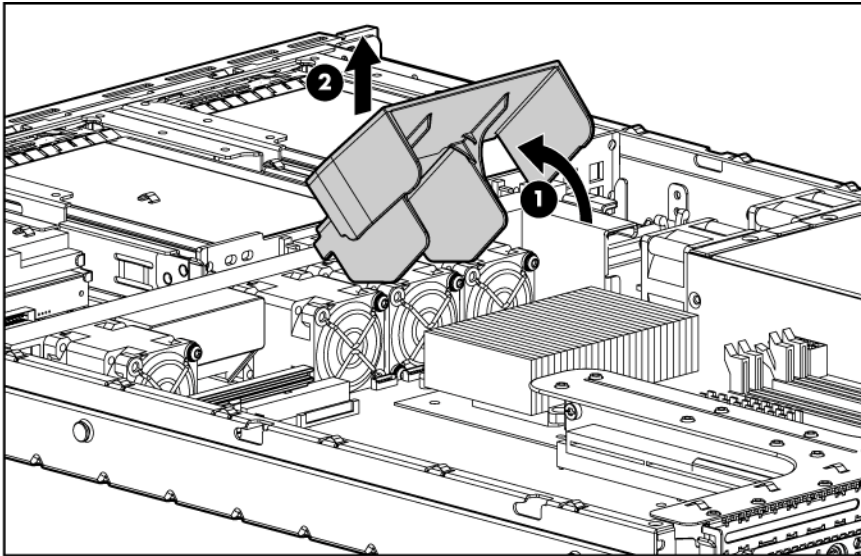

To replace the component, reverse the removal procedure.

Fan assembly

To remove the component:

1. Power down the server (on page 26).
2. Extend the server from the rack (on page 25).
3. Remove the access panel ("Access panel" on page 27).
4. Remove the air baffle ("Air baffle" on page 29).
5. Disconnect the fan cables from the system board.
6. Remove the fan assembly.

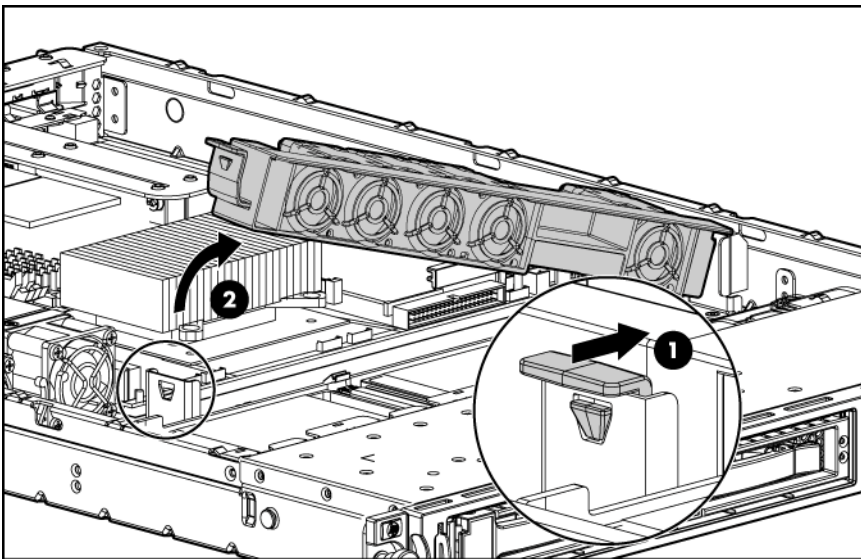

To replace the component, reverse the removal procedure.

BBWC battery holder

To remove the component:

1. Power down the server (on page 26).
2. Extend the server from the rack (on page 25).
3. Remove the access panel ("Access panel" on page 27).
4. Remove the air baffle ("Air baffle" on page 29).
5. Remove the fan assembly ("Fan assembly" on page 30).
6. Disconnect cables from any devices installed in the media cage, if necessary.
7. Remove the BBWC battery holder.

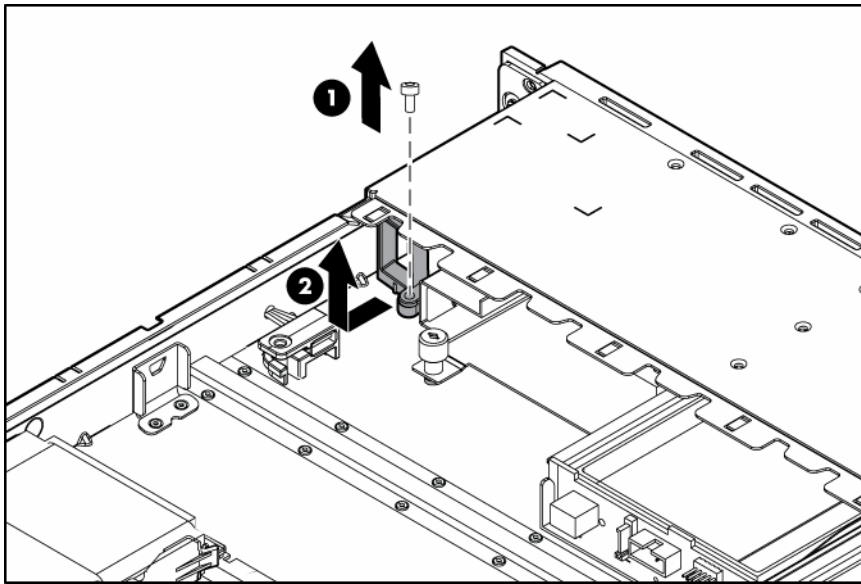

To replace the component, reverse the removal procedure.

BBWC battery

To remove the component:

1. Power down the server (on page 26).
2. Extend the server from the rack (on page 25).
3. Remove the access panel ("Access panel" on page 27).
4. Remove the air baffle ("Air baffle" on page 29).
5. Remove the fan assembly ("Fan assembly" on page 30).
6. Disconnect cables from any devices installed in the media cage, if necessary.
7. Disconnect the BBWC cable ("Battery-backed write cache cable routing" on page 61).

8. Remove the BBWC holder and battery.

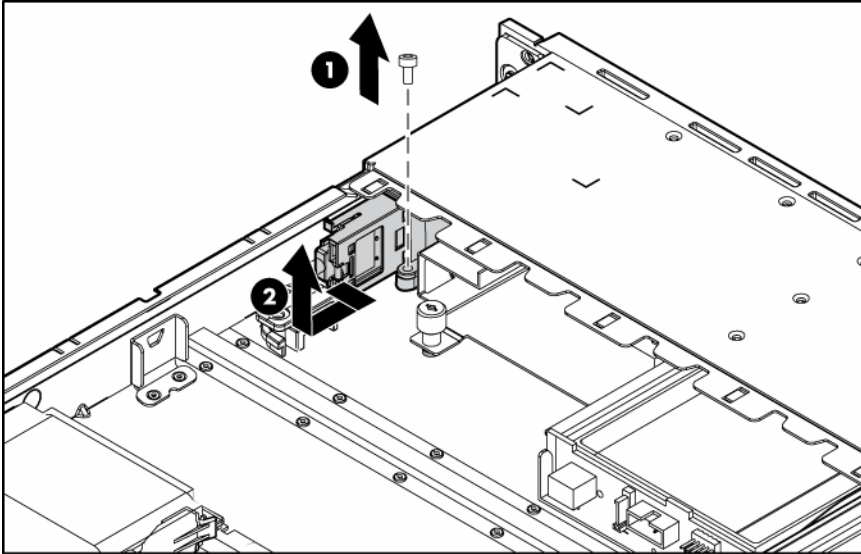

To replace the component, reverse the removal procedure.

Media cage

To remove the component:

CAUTION: To prevent improper cooling and thermal damage, do not operate the server unless all bays are populated with either a component or a blank.

1. Power down the server (on page 26).
2. Extend the server from the rack (on page 25).
3. Remove the access panel ("Access panel" on page 27).
4. Remove the air baffle ("Air baffle" on page 29).
5. Remove the fan assembly ("Fan assembly" on page 30).
6. Disconnect cables from any devices installed in the media cage, if necessary.
7. Disconnect the power button/LED board cable ("Power button/LED board" on page 36).
8. Remove the BBWC battery holder and optional battery with cable, if installed ("BBWC battery holder" on page 31).

9. Remove the media cage.

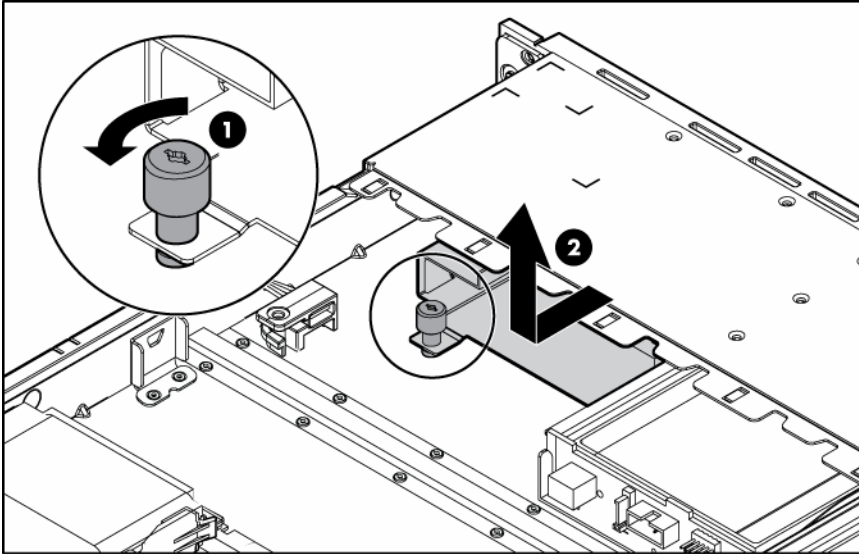

To replace the component, reverse the removal procedure.

Optical drive

To remove the component:

CAUTION: To prevent improper cooling and thermal damage, do not operate the server unless all bays are populated with either a component or a blank.

1. Power down the server (on page 26).
2. Extend the server from the rack (on page 25).
3. Remove the access panel ("Access panel" on page 27).
4. Remove the air baffle ("Air baffle" on page 29).
5. Remove the fan assembly ("Fan assembly" on page 30).
6. Disconnect cables from any devices installed in the media cage, if necessary.
7. Disconnect the power button/LED board cable ("Power button/LED board" on page 36).
8. Remove the BBWC battery holder and optional battery with cable, if installed ("BBWC battery holder" on page 31).
9. Remove the media cage ("Media cage" on page 32).

10. Remove the optical drive.

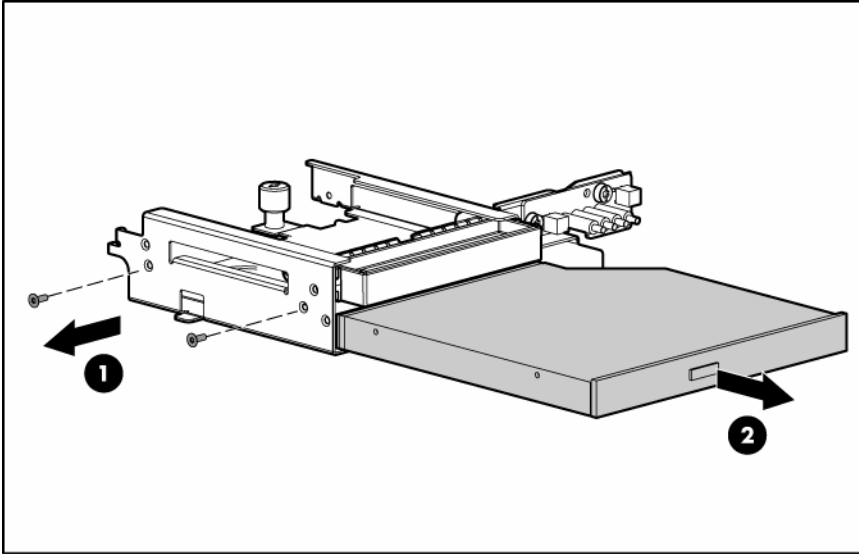

To replace the component, reverse the removal procedure.

Diskette drive

To remove the component:

CAUTION: To prevent improper cooling and thermal damage, do not operate the server unless all bays are populated with either a component or a blank.

1. Power down the server (on page 26).
2. Extend the server from the rack (on page 25).
3. Remove the access panel ("Access panel" on page 27).
4. Remove the air baffle ("Air baffle" on page 29).
5. Remove the fan assembly ("Fan assembly" on page 30).
6. Disconnect cables from any devices installed in the media cage, if necessary.
7. Disconnect the power button/LED board cable ("Power button/LED board" on page 36).
8. Remove the BBWC battery holder and optional battery with cable, if installed ("BBWC battery holder" on page 31).
9. Remove the media cage ("Media cage" on page 32).

10. Remove the diskette drive.

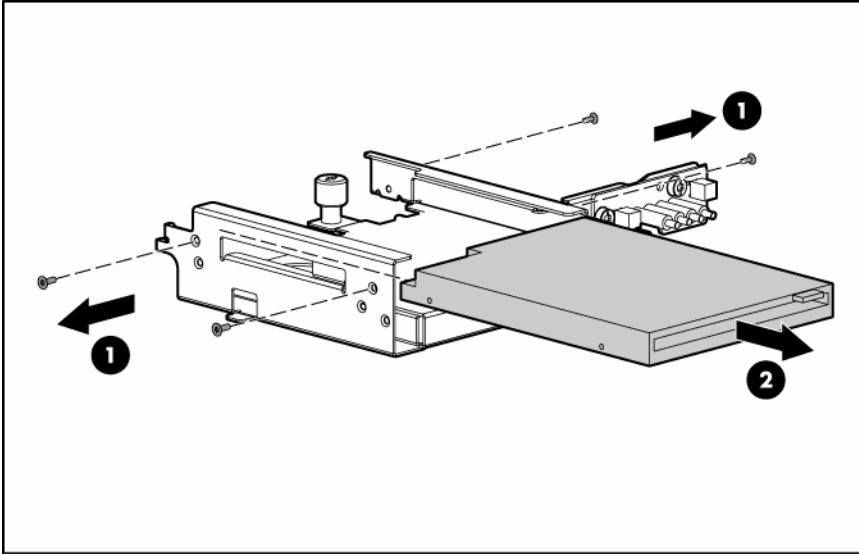

To replace the component, reverse the removal procedure.

Front video connector

To remove the component:

CAUTION: To prevent improper cooling and thermal damage, do not operate the server unless all bays are populated with either a component or a blank.

1. Power down the server (on page 26).
2. Extend the server from the rack (on page 25).
3. Remove the access panel ("Access panel" on page 27).
4. Remove the air baffle ("Air baffle" on page 29).
5. Remove the fan assembly ("Fan assembly" on page 30).
6. Disconnect cables from any devices installed in the media cage, if necessary.
7. Disconnect the power button/LED board cable ("Power button/LED board" on page 36).
8. Remove the BBWC battery holder and optional battery with cable, if installed ("BBWC battery holder" on page 31).
9. Remove the media cage ("Media cage" on page 32).

10. Remove the front video connector.

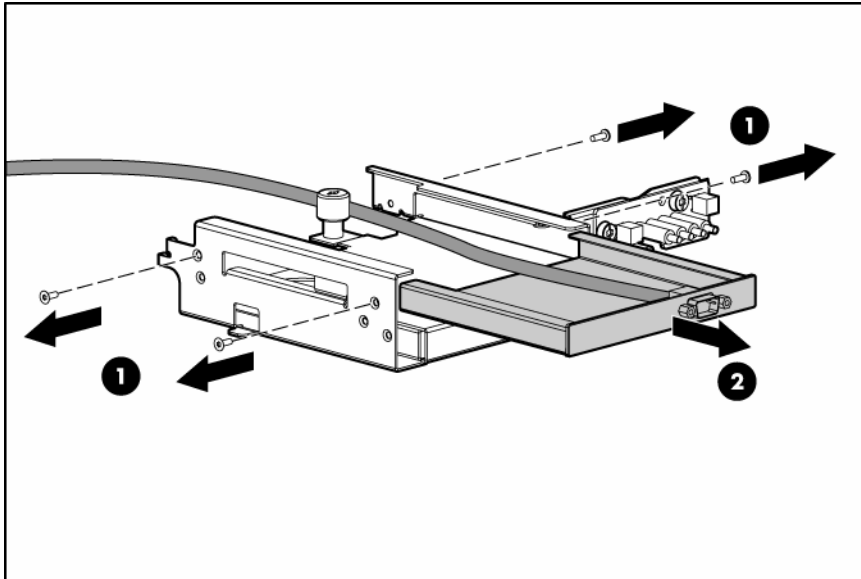

To replace the component, reverse the removal procedure.

Power button/LED board

To remove the component:

1. Power down the server (on page 26).
2. Extend the server from the rack (on page 25).
3. Remove the access panel ("Access panel" on page 27).
4. Remove the air baffle ("Air baffle" on page 29).
5. Remove the fan assembly ("Fan assembly" on page 30).
6. Disconnect cables from any devices installed in the media cage, if necessary.
7. Remove the BBWC battery holder and optional battery with cable, if installed ("BBWC battery holder" on page 31).

8. Disconnect the power button/LED board cable.

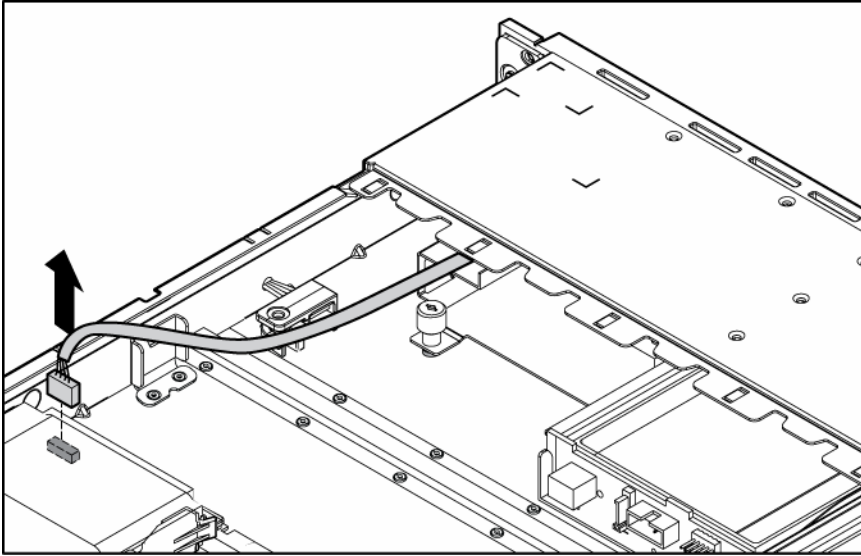

9. Remove the media cage ("Media cage" on page 32).
10. Remove the power button/LED board.

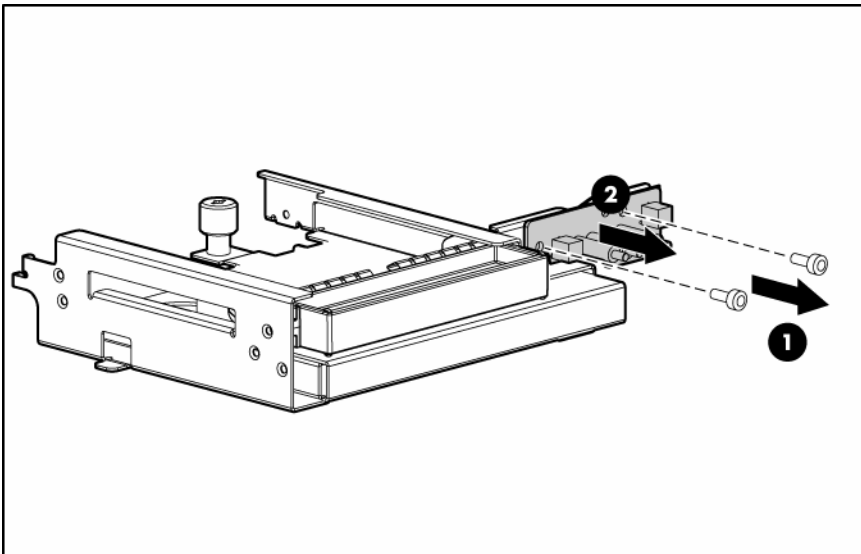

To replace the component, reverse the removal procedure.

Front bezel

1. Power down the server (on page 26).
2. Extend the server from the rack (on page 25).

3. Remove the serial label pull tab by extending it out, and then pressing on the underside to release it from the chassis.

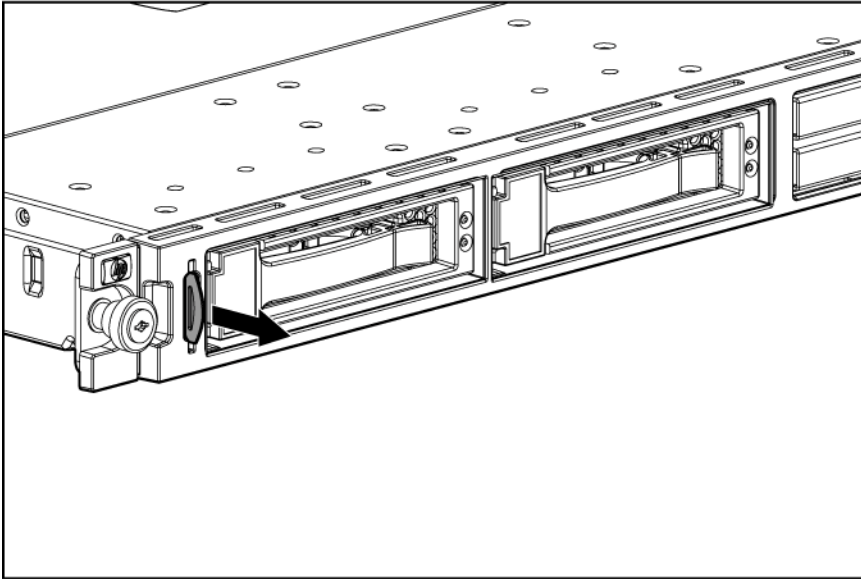

4. Remove the access panel ("Access panel" on page 27).
5. Remove all hard drives ("Hard drives" on page 27).
6. Remove all hard drive blanks ("Hard drive blanks" on page 28).
7. Remove the media cage ("Media cage" on page 32).
8. Use the T-10 Torx screwdriver to loosen the two T-10 screws on each side of the front bezel. The T-10/T-15 Torx screwdriver is located on the rear of the server.
9. Slide the bezel to the left, release the USB cover by gently lifting the plastic latch, and then detach the bezel.

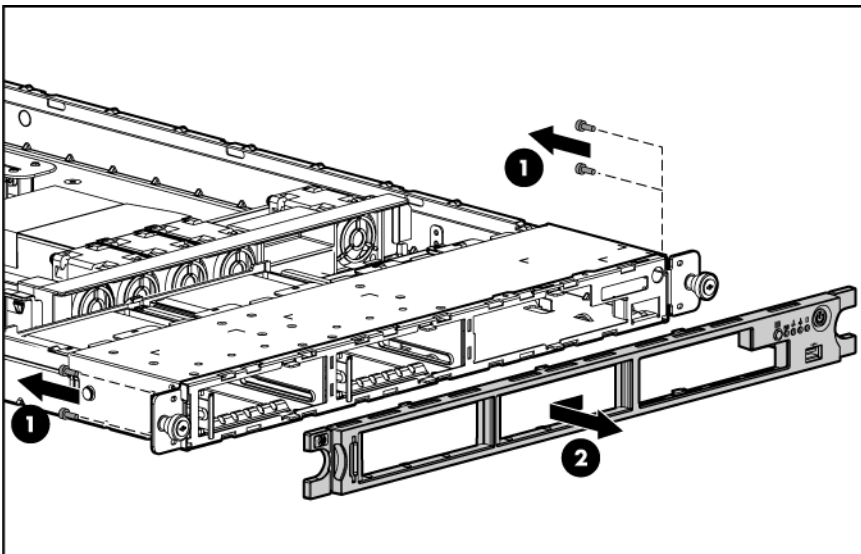

To replace the component, reverse the removal procedure.

PCI riser board assembly

To remove the component:

CAUTION: To prevent damage to the server or expansion boards, power down the server and remove all AC power cords before removing or installing the PCI riser board assembly.

1. Power down the server (on page 26).
2. Extend the server from the rack (on page 25).
3. Remove the access panel ("Access panel" on page 27).
4. Disconnect any internal or external cables connected to any existing expansion boards.
5. Remove the PCI riser board assembly.

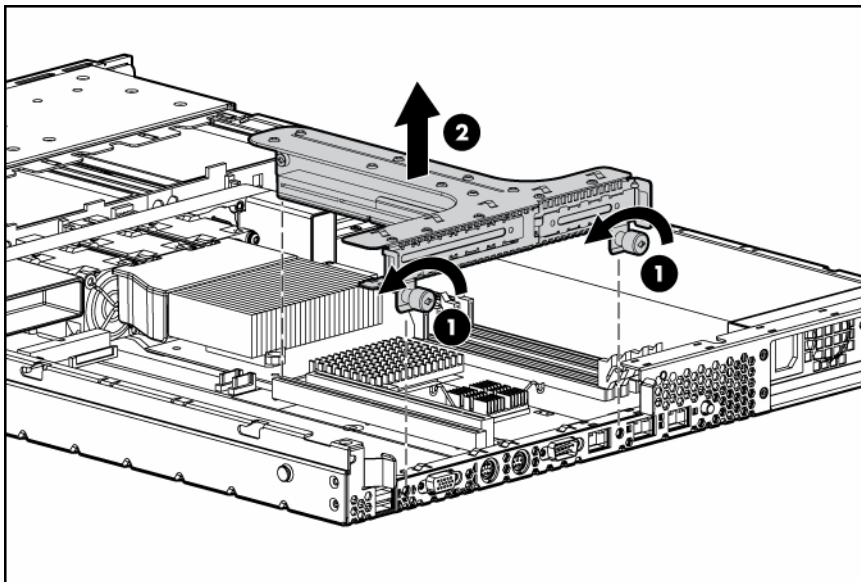

To replace the component, reverse the removal procedure.

Expansion boards

To remove the component:

1. Power down the server (on page 26).
2. Extend the server from the rack (on page 25).
3. Remove the access panel ("Access panel" on page 27).
4. Remove the PCI riser board assembly ("PCI riser board assembly" on page 39).

5. Remove any installed expansion boards.

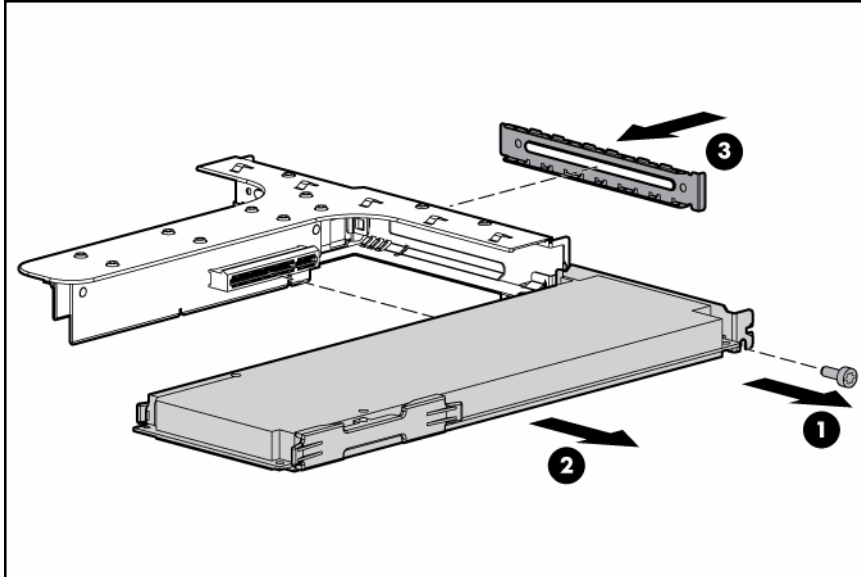

To replace the component, reverse the removal procedure.

Storage controller

To remove the component:

1. Power down the server (on page 26).
2. Extend the server from the rack (on page 25).
3. Remove the access panel ("Access panel" on page 27).
4. Disconnect the storage controller cable.

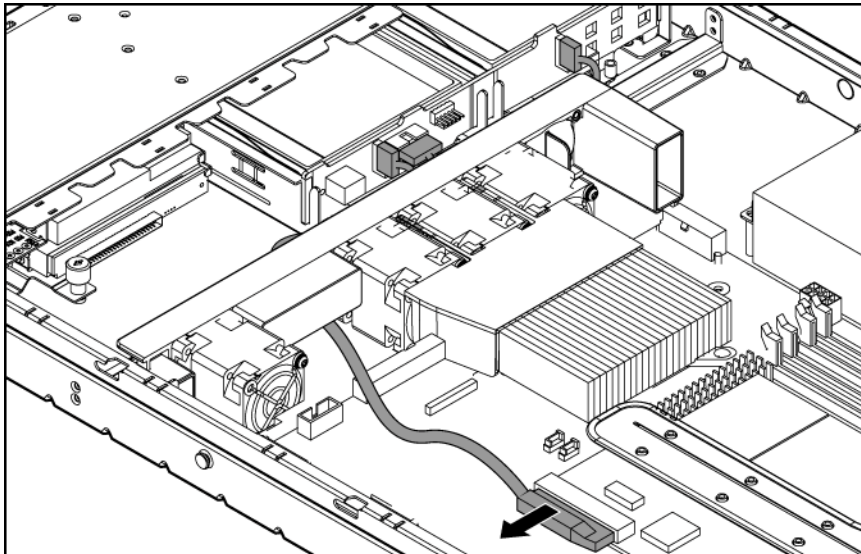

5. Remove the PCI riser board assembly ("PCI riser board assembly" on page 39).

6. Remove the storage controller.

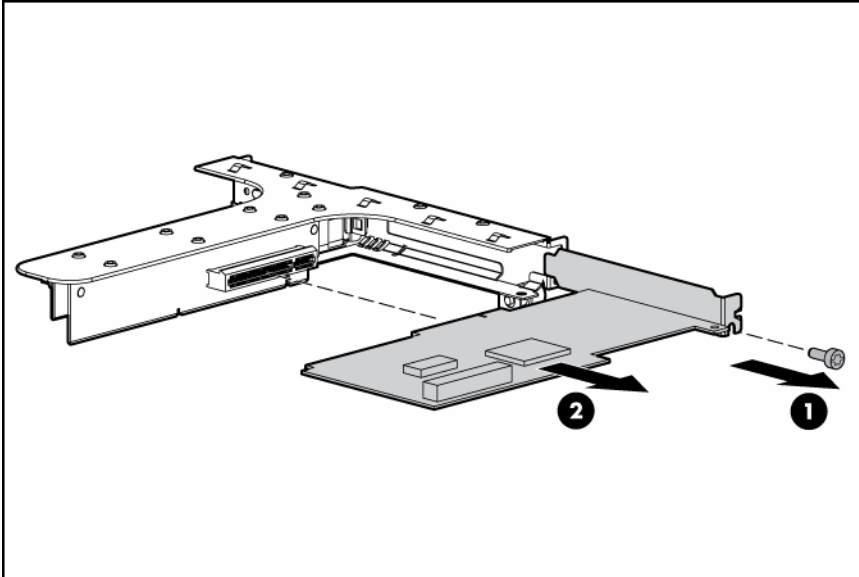

To replace the component, reverse the removal procedure.

PCI Express or PCI-X riser board

To remove the component:

1. Power down the server (on page 26).
2. Extend the server from the rack (on page 25).
3. Remove the access panel ("Access panel" on page 27).
4. Remove the PCI riser board assembly ("PCI riser board assembly" on page 39).
5. Remove the expansion board ("Expansion boards" on page 39).
6. Remove the PCI Express or PCI-X riser board.

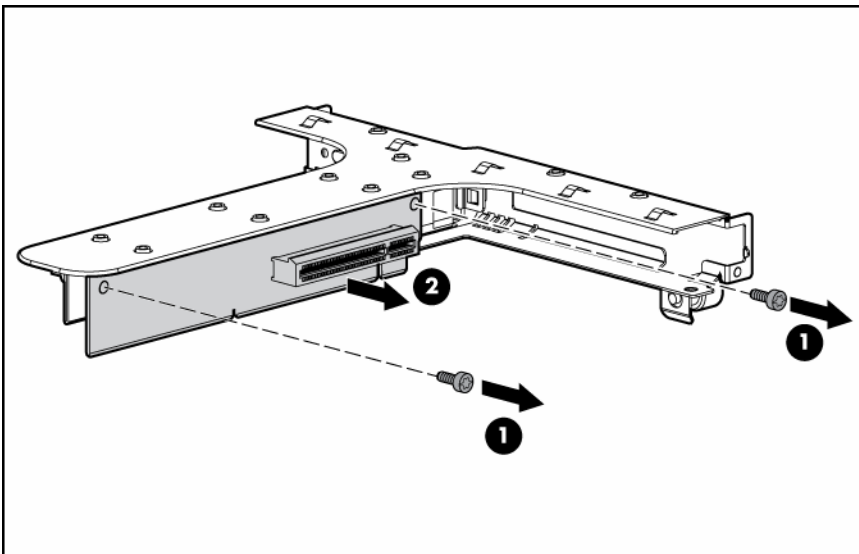

To replace the component, reverse the removal procedure.

DIMMs

To remove the component:

1. Power down the server (on page 26).
2. Extend the server from the rack (on page 25).
3. Remove the access panel ("Access panel" on page 27).
4. Open the DIMM slot latches.
5. Remove the DIMM.

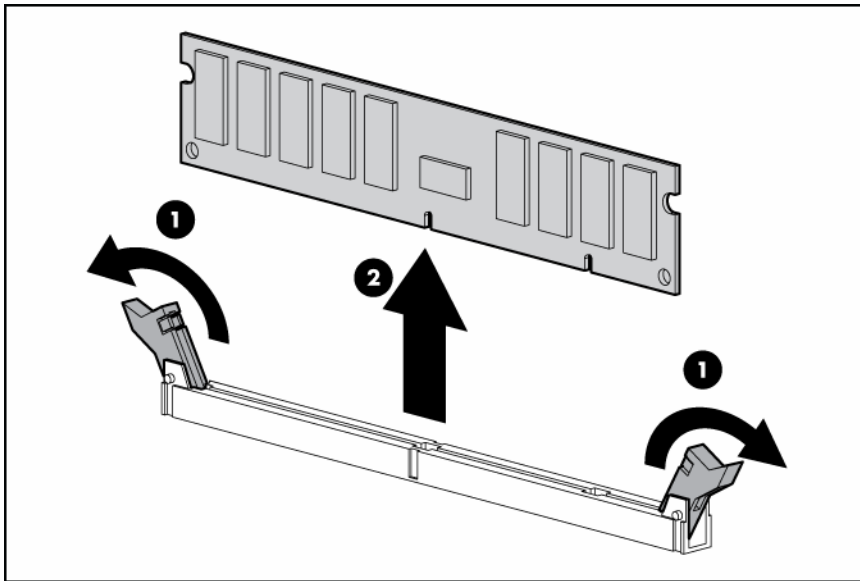

To replace the component, reverse the removal procedure.

Memory options

The server memory can be expanded by installing PC5300 DDR2 unbuffered SDRAM DIMMs. The server supports up to four ECC DDR2 SDRAM DIMMs.

The server supports standard memory configuration for maximum performance with up to 8 GB of active memory (four 2-GB memory modules).

DIMM installation guidelines

Observe the following guidelines when installing additional memory:

- DIMMs installed in the server must be unbuffered DDR2 SDRAM, 2.5 V, 64 bits wide, and ECC.
- All DIMMs installed must be the same speed (DDR2 PC5300). Do not install DIMMs supporting different speeds.
- If only a single DIMM is installed, HP recommends installing it in slot 1A.

BIOS detects the DIMM population and sets the system as follows:

- Single-bank mode: DIMMs installed in one bank only.
- Dual-bank interleaved mode: DIMMs installed in both banks with equal bank capacities.

The following table lists some, but not all, possible configurations. For best performance, HP recommends dual-bank interleaved mode configurations.

Slot 1A	Slot 2B	Slot 3A	Slot 4B	Total memory	Mode
512 MB	—	—	—	512 MB	Single-bank
512 MB	—	512 MB	—	1 GB	Dual-bank interleaved
1 GB	—	—	—	1 GB	Single-bank
1 GB	—	1 GB	—	2 GB	Dual-bank interleaved
1 GB	1 GB	1 GB	1 GB	4 GB	Dual-bank interleaved

Interleaving and non-interleaving memory configuration

The server supports interleaving and non-interleaving memory configurations. Interleaving memory increases bandwidth by enabling simultaneous access to multiple blocks of data. For example, to overlap read-writes, the server divides the system memory between pairs of DIMMs, and then writes to and reads from each DIMM concurrently. For an interleaving configuration, always install identical DIMMs in pairs. For a non-interleaving configuration, install a single DIMM in slot 1 only.

Power supply

To remove the component:

1. Power down the server (on page 26).
2. Remove the server from the rack (on page 26).
3. Remove the access panel ("Access panel" on page 27).
4. Unfasten the cable clip and lift the cables to access the front screw.

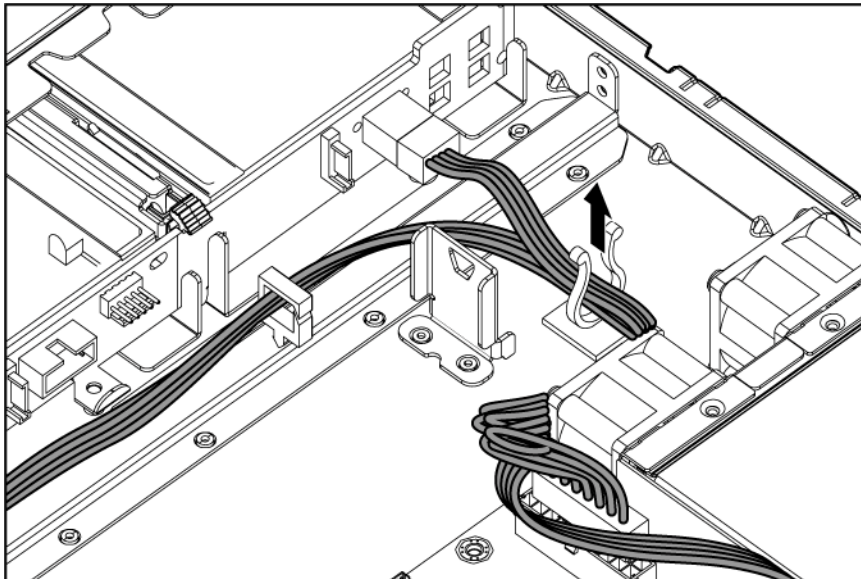

5. Remove the three screws that secure the power supply unit to the chassis.
6. Disconnect the removable media and hard drive power cables.
7. Disconnect the auxiliary power supply cable and the main power supply cable from the system board by pressing each locking tab on the side of the connector and pulling upwards.

8. Remove the power supply.

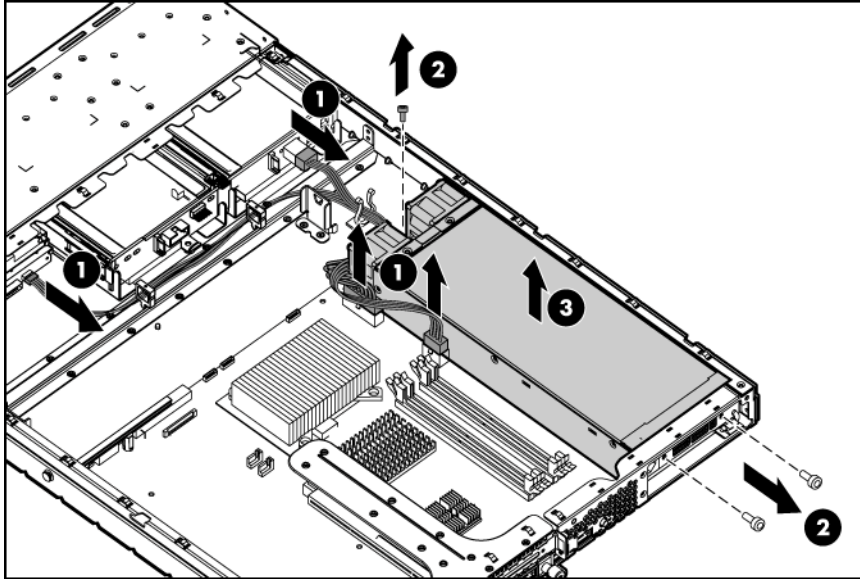

To replace the component, reverse the removal procedure.

Heatsink

To remove the component:

-
- ⚠ **WARNING:** To reduce the risk of personal injury from hot surfaces, allow the drives and the internal system components to cool before touching them.
-
- ⚠ **CAUTION:** To prevent thermal instability and damage to the server, do not separate the processor from the heatsink. The processor, heatsink, and retaining clip make up a single assembly.
-
- ⚠ **CAUTION:** To prevent possible server malfunction, do not mix processors of different speeds or cache sizes. Refer to the label on the processor heatsink for a description of the processor.
-

1. Power down the server (on page 26).
2. Extend the server from the rack (on page 25).
3. Remove the access panel ("Access panel" on page 27).
4. Remove the air baffle ("Air baffle" on page 29).
5. Loosen the four screws securing the heatsink.
 - a. Loosen each screw three or four turns in the counterclockwise direction.
 - b. Fully loosen the screws to free the heatsink, being careful not to remove the screw assemblies from the heatsink.

-
- ⚠ **CAUTION:** Heatsink retaining screws should be tightened or loosened in diagonally opposite pairs (in an "X" pattern). Do not overtighten the screws as this can damage the board, connectors, or screws. Use the wrench supplied with the system to reduce the possibility of overtightening the screws.
-

6. Remove the heatsink.

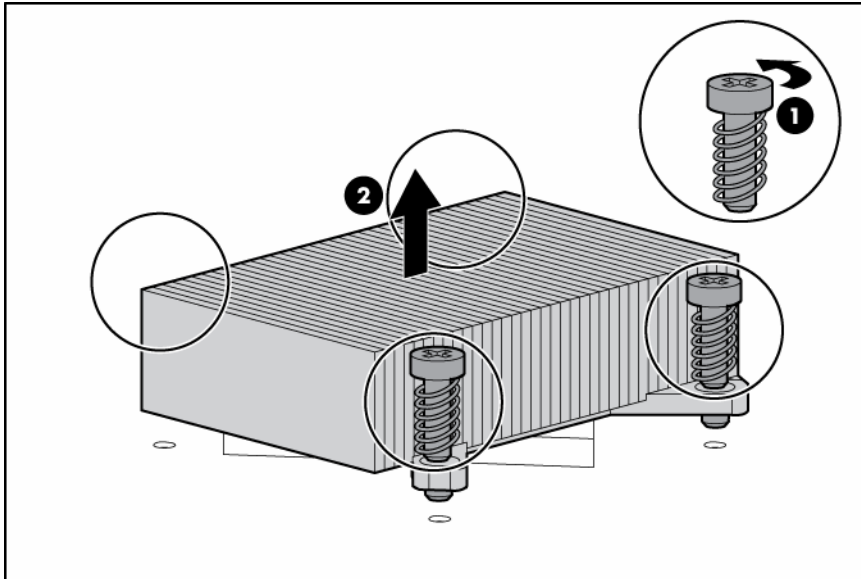

To replace the component:



IMPORTANT: When replacing the heatsink, check the label on top to be sure the heatsink is properly oriented.

1. Use the alcohol swab to remove all the existing thermal grease from the processor. Allow the alcohol to evaporate before continuing.



CAUTION: After the cover is removed, do not touch the thermal interface media.



CAUTION: The heatsink thermal interface media is not reusable and must be replaced if the heatsink is removed from the processor after it has been installed.

2. Remove the protective cover from the heatsink.

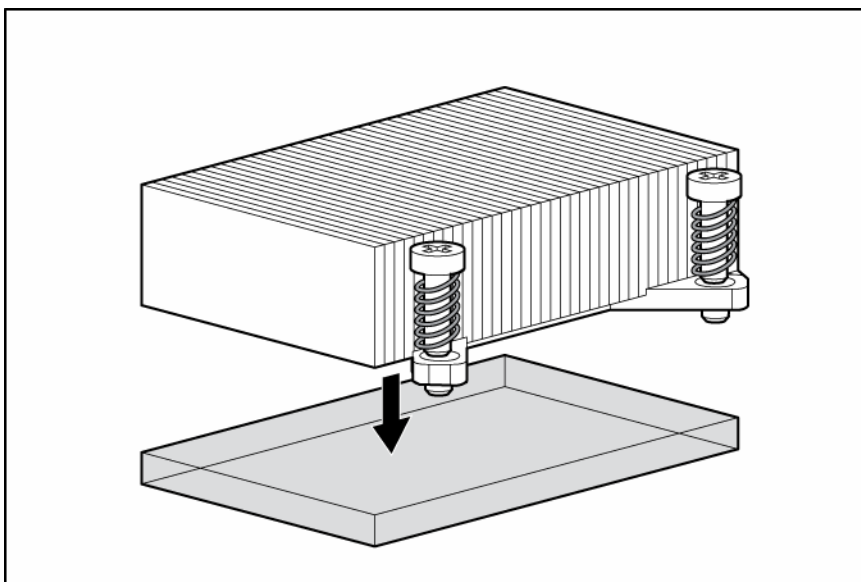

-
- △ **CAUTION:** Heatsink retaining screws should be tightened or loosened in diagonally opposite pairs (in an "X" pattern). Do not overtighten the screws as this can damage the board, connectors, or screws. Use the wrench supplied with the system to reduce the possibility of overtightening the screws.
-

3. Install the heatsink.

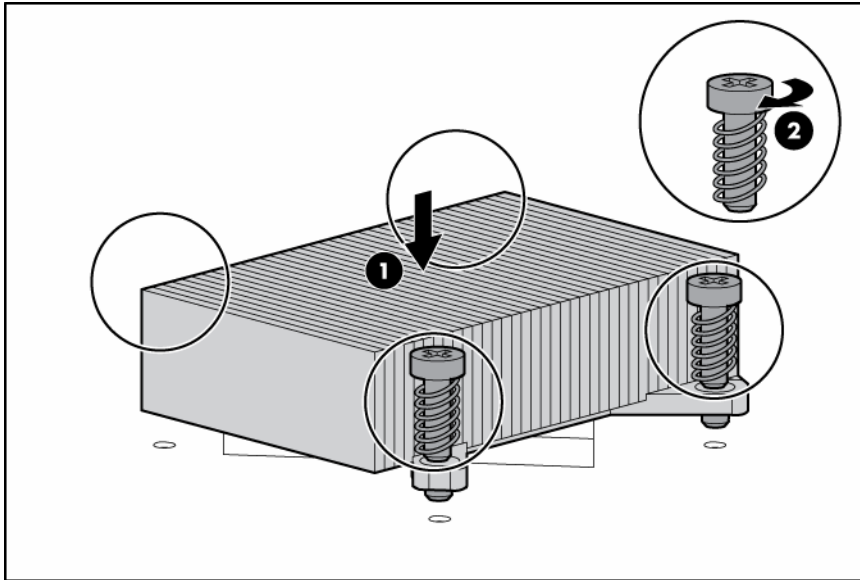

4. Install the air baffle.
5. Install the access panel.

Processor

To remove the component:

-
- △ **WARNING:** To reduce the risk of personal injury from hot surfaces, allow the drives and the internal system components to cool before touching them.
-
- △ **CAUTION:** To prevent thermal instability and damage to the server, do not separate the processor from the heatsink. The processor, heatsink, and retaining clip make up a single assembly.
-
- △ **CAUTION:** To prevent possible server malfunction, do not mix processors of different speeds or cache sizes. Refer to the label on the processor heatsink for a description of the processor.
-

1. Power down the server (on page 26).
2. Extend the server from the rack (on page 25).
3. Remove the access panel ("[Access panel](#)" on page 27).
4. Remove the air baffle ("[Air baffle](#)" on page 29).
5. Remove the heatsink ("[Heatsink](#)" on page 44).

6. Open the processor retaining latch and the processor socket retaining bracket.

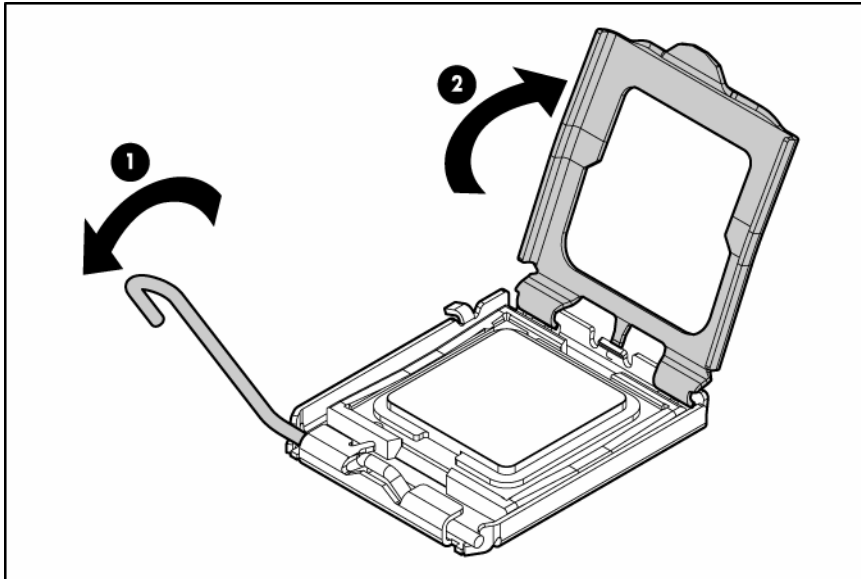

7. Using your fingers, remove the failed processor.

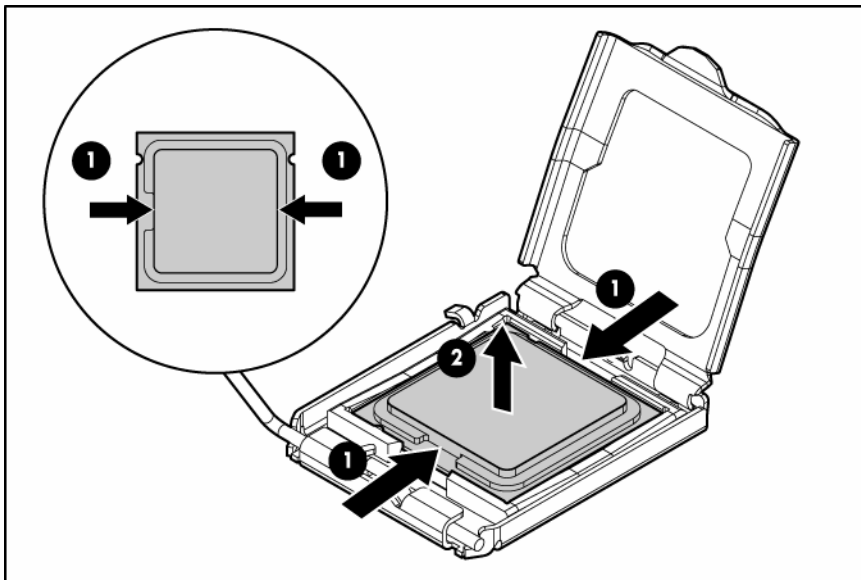

To replace the component:



IMPORTANT: Be sure the processor remains inside the processor installation tool.

1. If the processor has separated from the installation tool, carefully re-insert the processor in the tool.

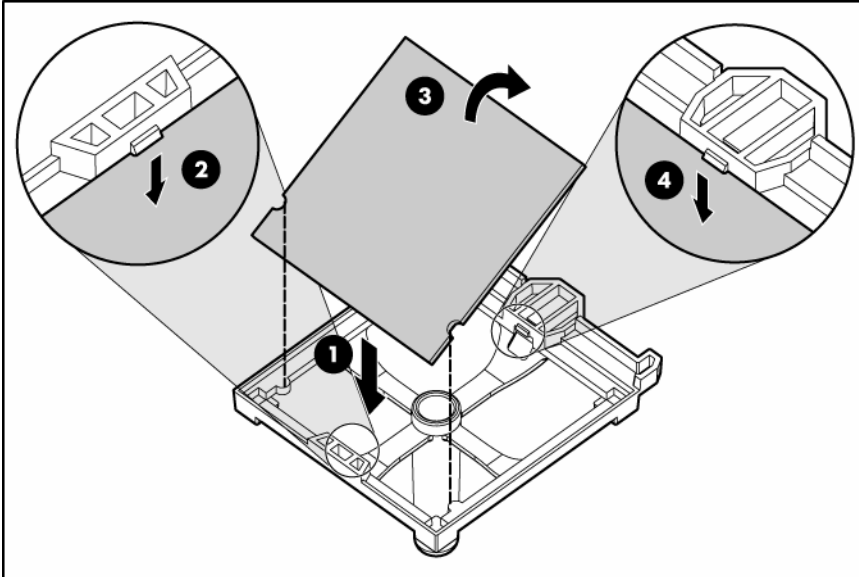

2. Align the processor installation tool with the socket and install the spare processor.

⚠ CAUTION: The processor is designed to fit one way into the socket. Use the alignment guides on the processor and socket to properly align the processor with the socket. Refer to the server hood label for specific instructions.

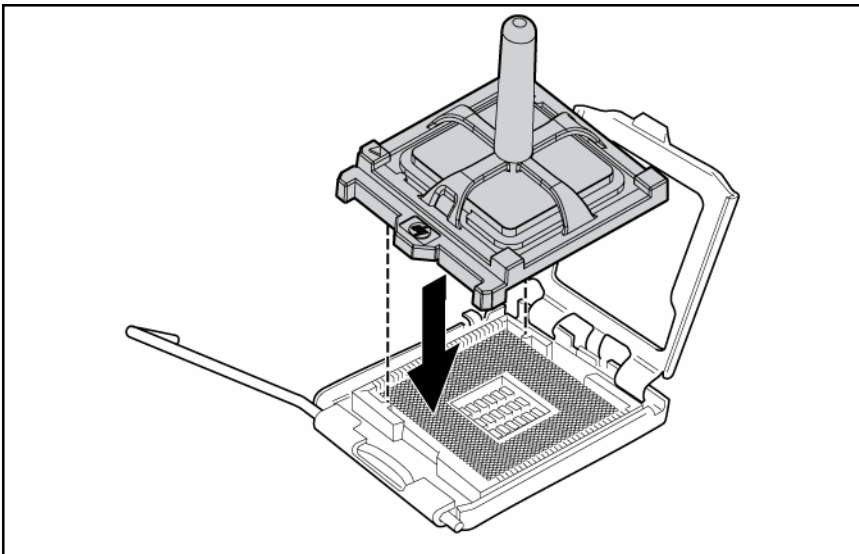

3. Press down firmly until the processor installation tool clicks and separates from the processor, and then remove the processor installation tool.

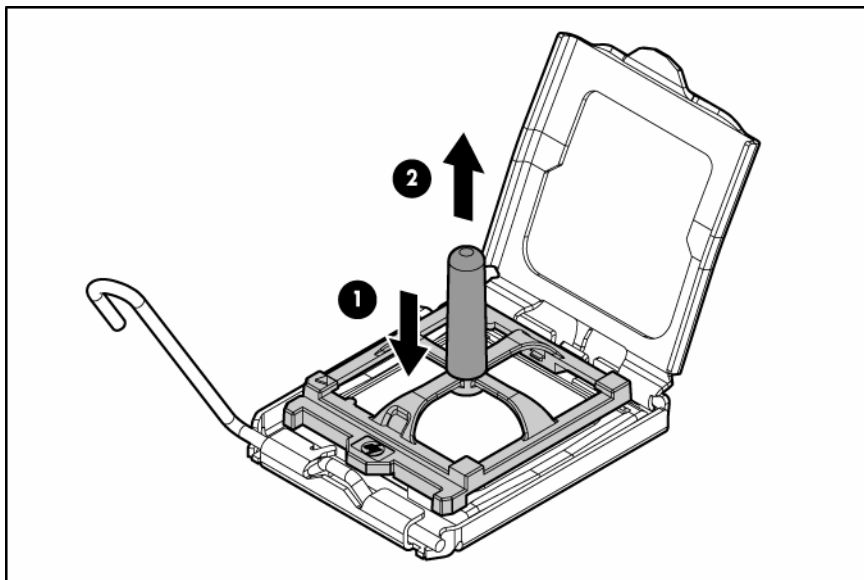

4. Close the processor retaining latch and the processor socket retaining bracket.

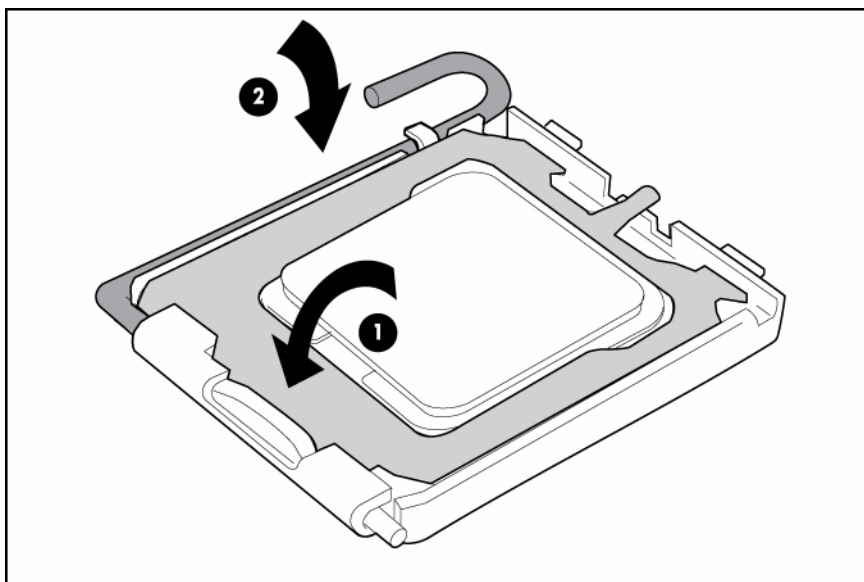

5. Clean the old thermal grease from the heatsink with the alcohol swab. Allow the alcohol to evaporate before continuing.

6. Apply all the grease to the top of the processor in one of the following patterns to ensure even distribution:

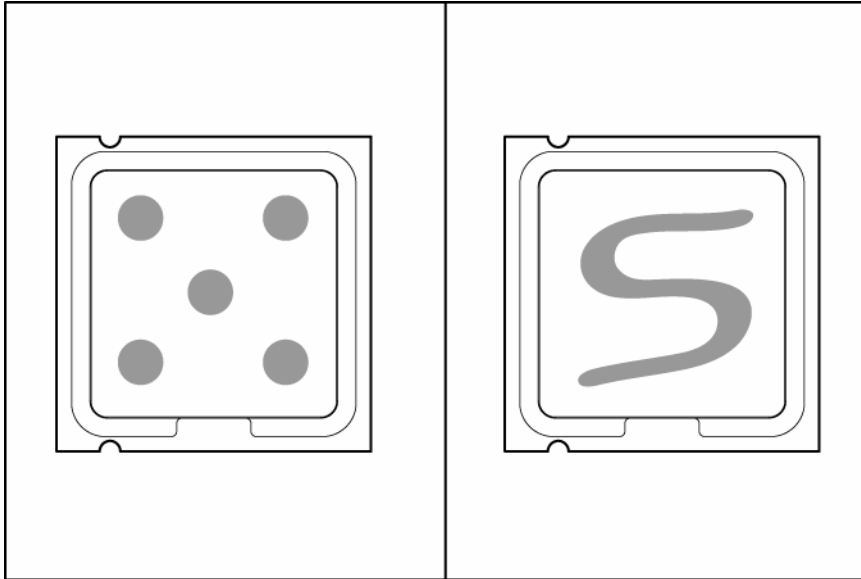

CAUTION: Heatsink retaining screws should be tightened or loosened in diagonally opposite pairs (in an "X" pattern). Do not overtighten the screws as this can damage the board, connectors, or screws. Use the wrench supplied with the system to reduce the possibility of overtightening the screws.

7. Install the heatsink.

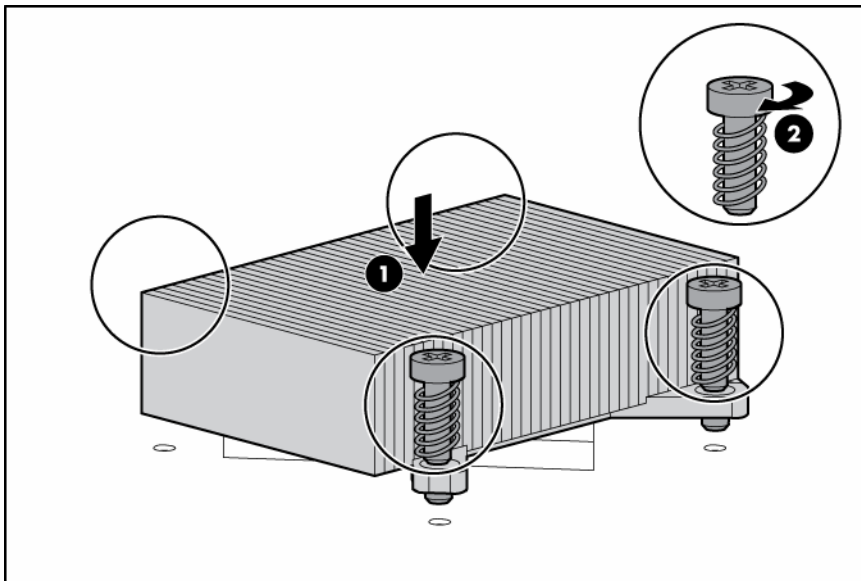

8. Install the air baffle.
9. Install the access panel.

System board

To remove the component:

1. Power down the server (on page 26).

2. Remove the server from the rack (on page 26).
3. Remove the access panel ("[Access panel](#)" on page 27).
4. Remove the PCI riser board assembly ("[PCI riser board assembly](#)" on page 39).
5. Remove all DIMMs ("[DIMMs](#)" on page 42).
6. Remove the air baffle ("[Air baffle](#)" on page 29).
7. Remove the fan assembly ("[Fan assembly](#)" on page 30).
8. Disconnect the power supply cables from the system board.
9. Disconnect the SATA hard drive cables from the system board ("[Cabling](#)" on page 58, "[Server cable routing](#)" on page 58).
10. Disconnect the media cage cables and the power button/LED board cable from the system board.
11. Remove the heatsink ("[Heatsink](#)" on page 44).
12. Open the processor retaining latch and the processor socket retaining bracket on the failed system board.

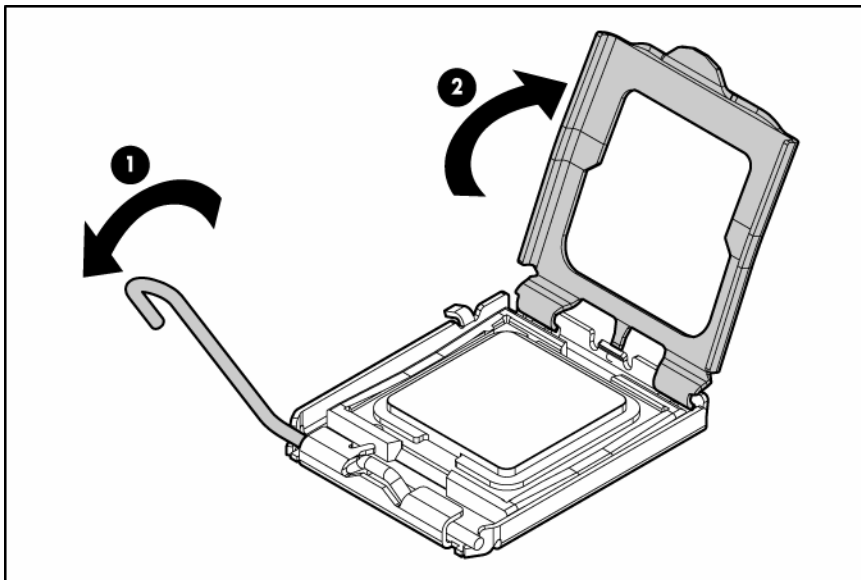

13. Using your fingers, remove the processor from the failed system board.

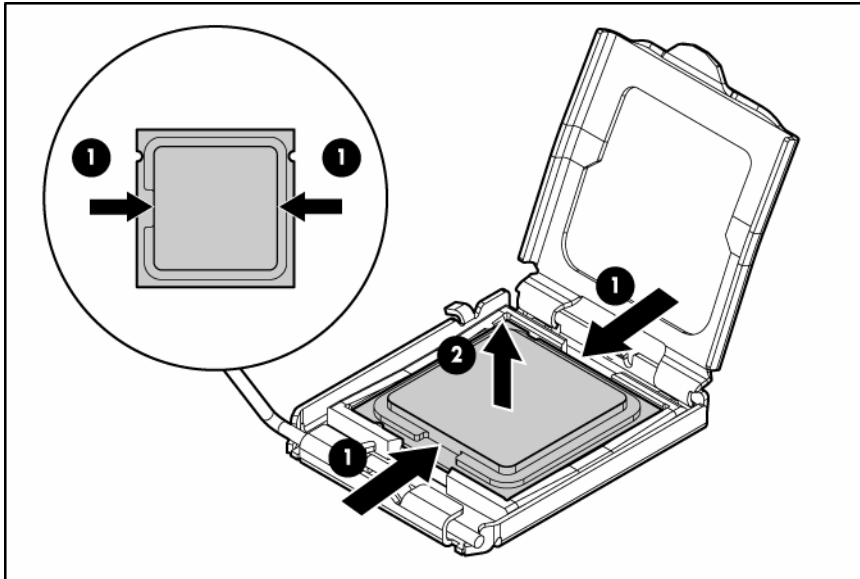

CAUTION: To avoid damage to the system board:

- Do not touch the processor socket contacts.
- Always install the processor socket cover after removing the processor from the socket.
- Do not tilt or slide the processor when lowering the processor into the socket.



CAUTION: To avoid damage to the processor:

- Handle the processor only by the edges.
- Do not touch the bottom of the processor, especially the contact area.

14. Remove the seven T-15 screws securing the failed system board.

15. Remove the failed system board.

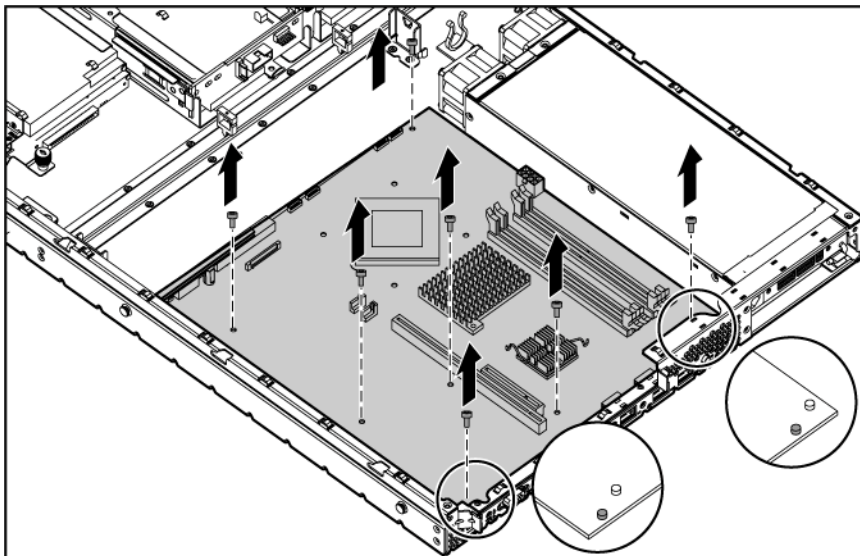

To replace the system board:

1. Install the spare system board in the server.

2. Prepare the processor socket on the spare system board:
 - a. Open the processor retaining latch and the processor socket retaining bracket.

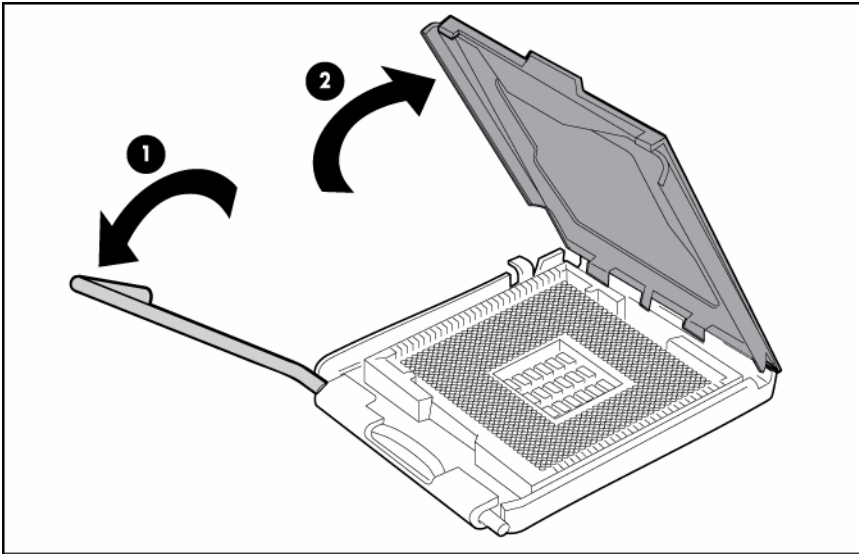

- b. Remove the processor socket protective cover.

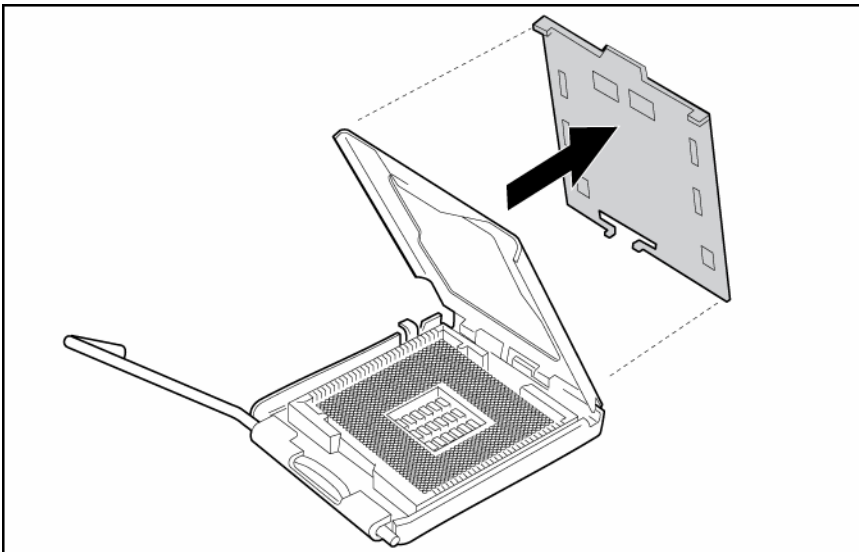

3. Install the processor socket cover onto the processor socket of the failed system board.
4. Install the processor on the spare system board.



CAUTION: The processor is designed to fit one way into the socket. Use the alignment guides on the processor and socket to properly align the processor with the socket. Refer to the server hood label for specific instructions.



CAUTION: Always install the processor parallel to the system board to avoid damage to the pins.

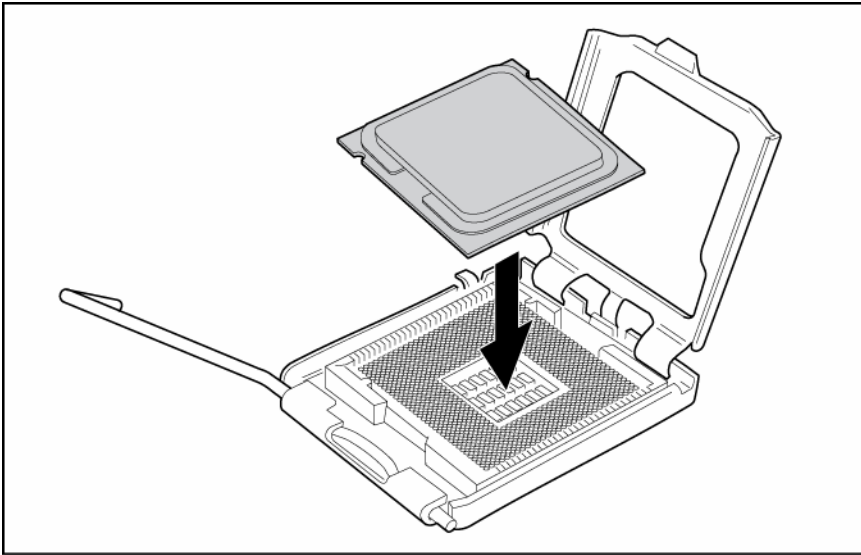

5. Close the processor retaining latch and the processor socket retaining bracket.

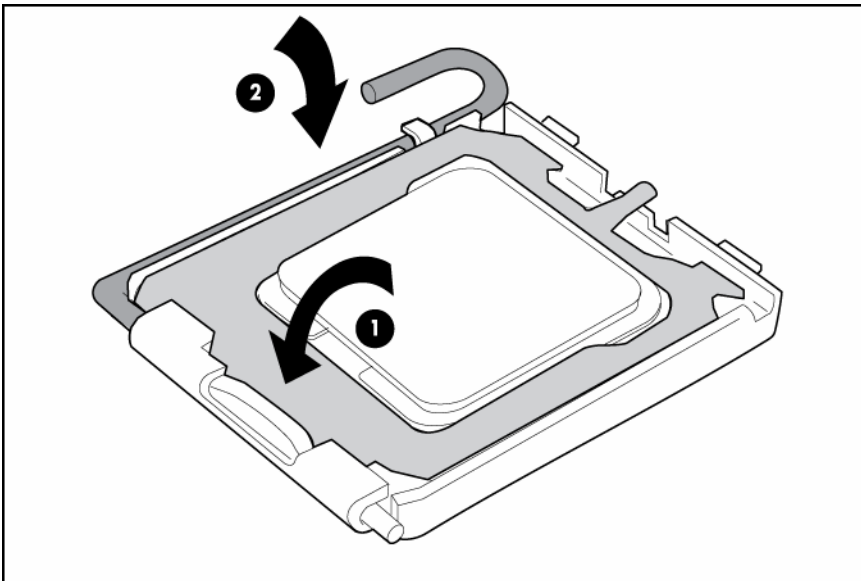

6. Clean the old thermal grease from the heatsink and the top of the processor with the alcohol swab. Allow the alcohol to evaporate before continuing.

7. Apply all the grease to the top of the processor in one of the following patterns to ensure even distribution:

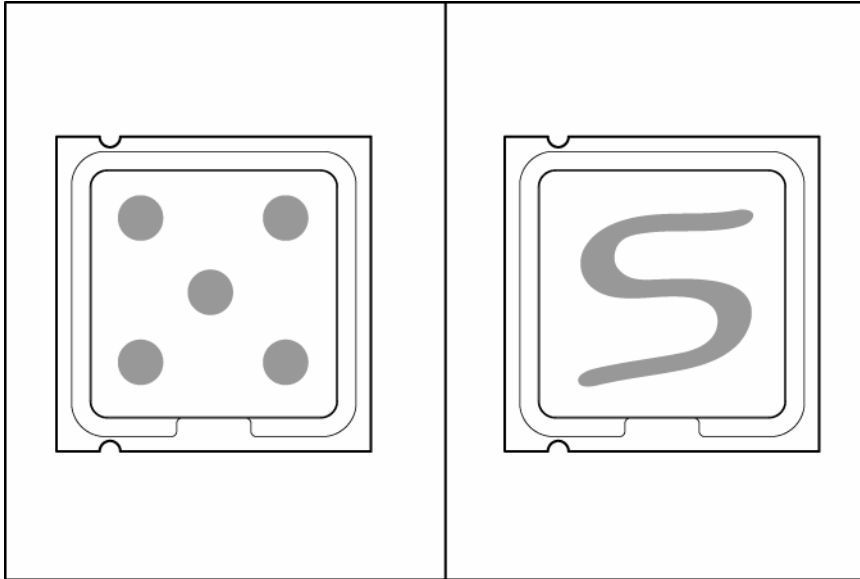

CAUTION: Heatsink retaining screws should be tightened or loosened in diagonally opposite pairs (in an "X" pattern). Do not overtighten the screws as this can damage the board, connectors, or screws. Use the wrench supplied with the system to reduce the possibility of overtightening the screws.

8. Install the heatsink.

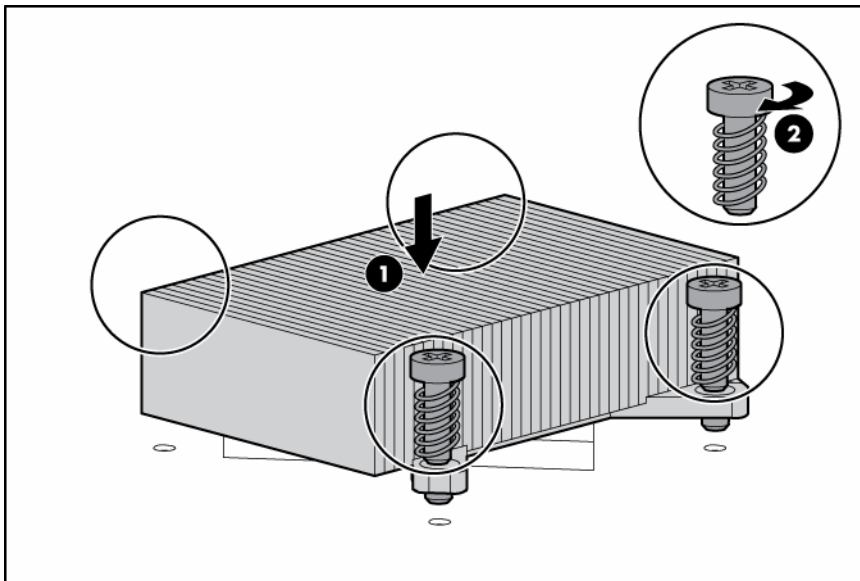

IMPORTANT: To ensure proper cooling, be sure the processor air baffle is installed at all times (if applicable).

9. Install all components removed from the failed system board.

IMPORTANT: Install all components with the same configuration that was used on the failed system board.

10. Install the access panel.
11. Power up the server.

After you replace the system board, you must re-enter the server serial number and the product ID.

1. During the server startup sequence, press the **F9** key to access RBSU.
2. Select the **Advanced Options** menu.
3. Select **Serial Number**. The following warning is displayed:
Warning: The serial number should ONLY be modified by qualified service personnel. This value should always match the serial number located on the chassis.
4. Press the **Enter** key to clear the warning.
5. Enter the serial number.
6. Select **Product ID**. The following warning is displayed:
Warning: The Product ID should ONLY be modified by qualified service personnel. This value should always match the Product ID located on the chassis.
7. Enter the product ID and press the **Enter** key.
8. Press the **Esc** key to close the menu.
9. Press the **Esc** key to exit RBSU.
10. Press the **F10** key to confirm exiting RBSU. The server will automatically reboot.

Battery

If the server no longer automatically displays the correct date and time, you may need to replace the battery that provides power to the real-time clock. Under normal use, battery life is 5 to 10 years.



WARNING: The computer contains an internal lithium manganese dioxide, a vanadium pentoxide, or an alkaline battery pack. A risk of fire and burns exists if the battery pack is not properly handled. To reduce the risk of personal injury:

- Do not attempt to recharge the battery.
- Do not expose the battery to temperatures higher than 60°C (140°F).
- Do not disassemble, crush, puncture, short external contacts, or dispose of in fire or water.
- Replace only with the spare designated for this product.

To remove the component:

1. Power down the server (on page 26).
2. Extend or remove the server from the rack ("[Extend the server from the rack](#)" on page 25).
3. Remove the access panel ("[Access panel](#)" on page 27).
4. Remove the PCI riser board assembly ("[PCI riser board assembly](#)" on page 39).



CAUTION: To prevent damage to the server or expansion boards, power down the server and remove all AC power cords before removing or installing the PCI riser cage.

5. Remove the battery.

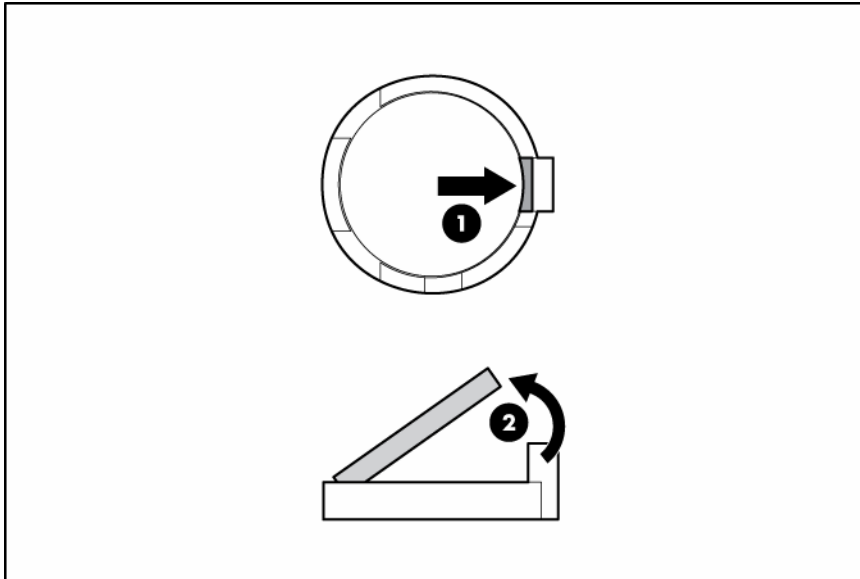

IMPORTANT: Replacing the system board battery resets the system ROM to its default configuration. After replacing the battery, reconfigure the system through RBSU.

To replace the component, reverse the removal procedure.

For more information about battery replacement or proper disposal, contact an authorized reseller or an authorized service provider.

Cabling

Server cable routing

⚠ **CAUTION:** When routing cables, always be sure that the cables are not in a position where they can be pinched or air flow can be blocked.

📝 **IMPORTANT:** Route the cables without blocking the airflow or other installed components. Use the cable clips installed in the chassis to manage cable routing.

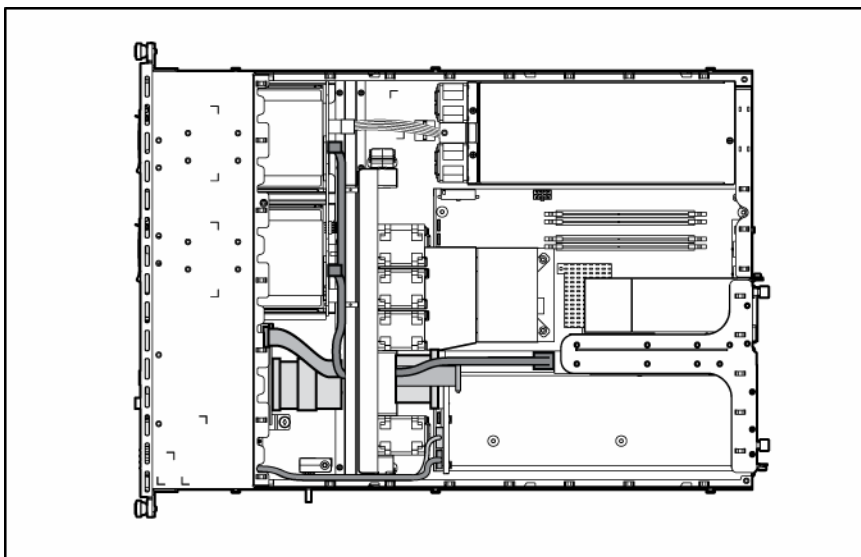

Embedded SATA controller cable routing

⚠ **CAUTION:** When routing cables, always be sure that the cables are not in a position where they can be pinched or air flow can be blocked.

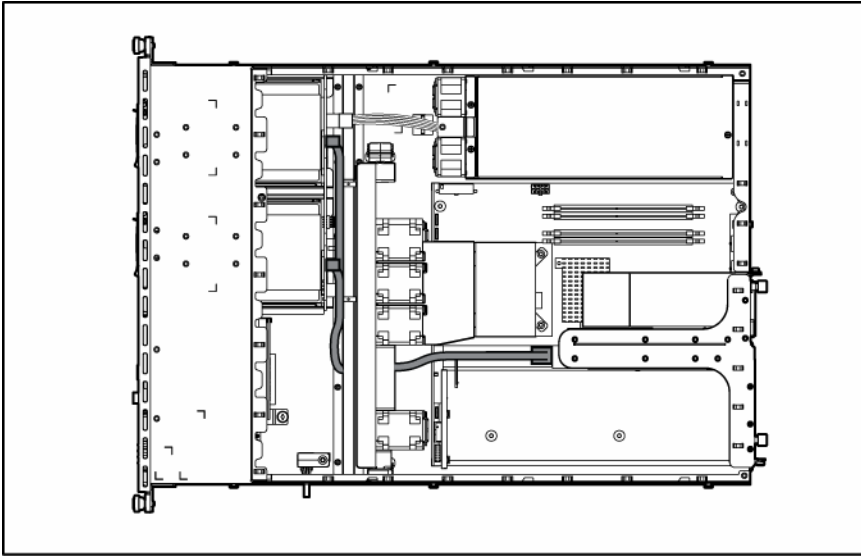

Optional SAS/SATA controller cable routing

△ **CAUTION:** When routing cables, always be sure that the cables are not in a position where they can be pinched or air flow can be blocked.

Slot 2

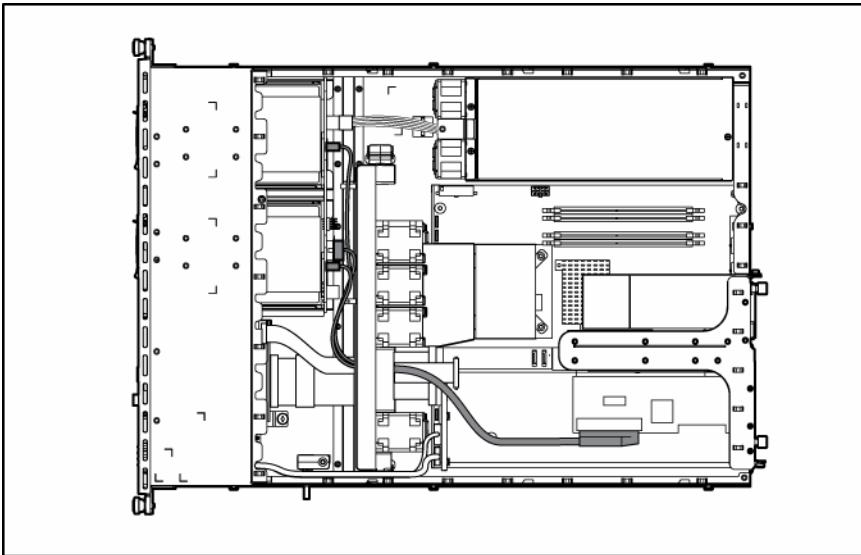

Slot 1

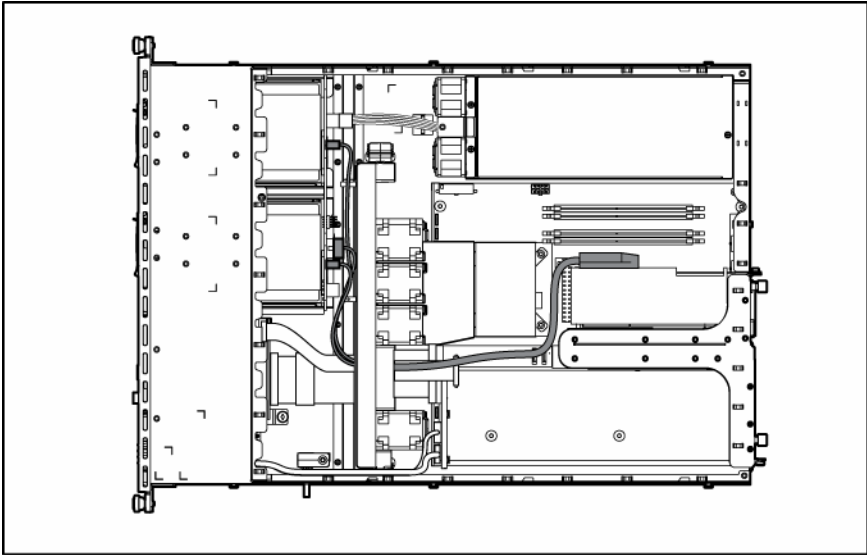

Video connector option cable routing

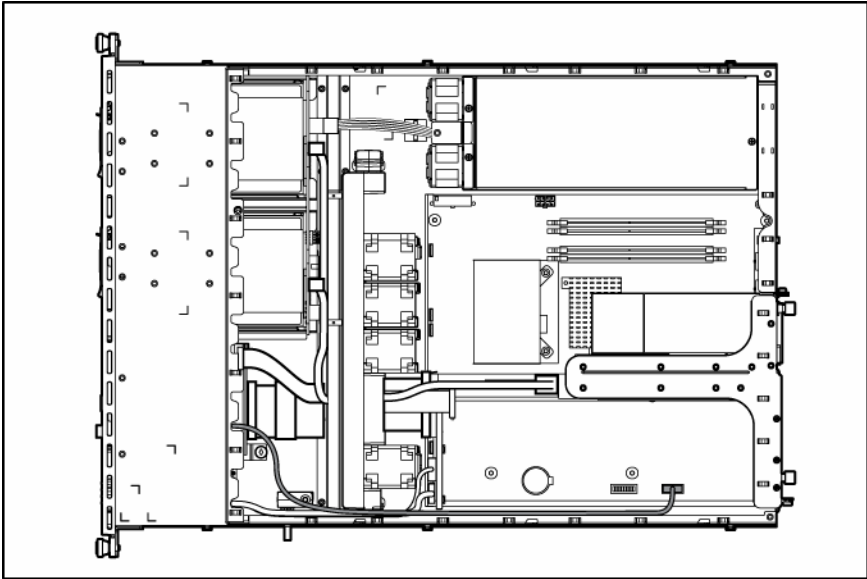

Battery-backed write cache cable routing

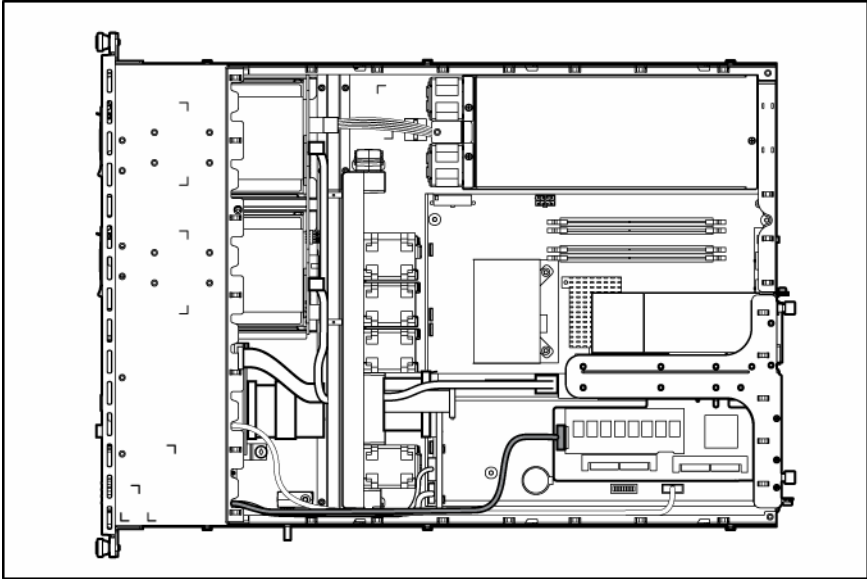

Diagnostic tools

Troubleshooting resources

The *HP ProLiant Servers Troubleshooting Guide* provides simple procedures for resolving common problems as well as a comprehensive course of action for fault isolation and identification, error message interpretation, issue resolution, and software maintenance.

To obtain the guide, refer to any of the following sources and then select the *HP ProLiant Servers Troubleshooting Guide*:

- The server-specific Documentation CD
- The Business Support Center on the HP website (<http://www.hp.com/support>). Navigate to the server technical support page. Under self-help resources, select **ProLiant Troubleshooting Guide**.
- The Technical Documentation website (<http://www.docs.hp.com>). Select **Enterprise Servers, Workstations and Systems Hardware**, and then the appropriate server.

HP Insight Diagnostics

HP Insight Diagnostics is a proactive server management tool, available in both offline and online versions, that provides diagnostics and troubleshooting capabilities to assist IT administrators who verify server installations, troubleshoot problems, and perform repair validation.

HP Insight Diagnostics Offline Edition performs various in-depth system and component testing while the OS is not running. To run this utility, launch the SmartStart CD.

HP Insight Diagnostics Online Edition is a web-based application that captures system configuration and other related data needed for effective server management. Available in Microsoft® Windows® and Linux versions, the utility helps to ensure proper system operation.

For more information or to download the utility, refer to the HP website (<http://www.hp.com/servers/diags>).

HP Insight Diagnostics survey functionality

HP Insight Diagnostics (on page 62) provides survey functionality that gathers critical hardware and software information on ProLiant servers.

This functionality supports operating systems that may not be supported by the server. For operating systems supported by the server, see the HP website (<http://www.hp.com/go/supportos>).

If a significant change occurs between data-gathering intervals, the survey function marks the previous information and overwrites the survey data files to reflect the latest changes in the configuration.

Survey functionality is installed with every SmartStart-assisted HP Insight Diagnostics installation, or it can be installed through the HP PSP.

NOTE: The current version of SmartStart provides the memory spare part numbers for the server. To download the latest version, see the HP website (<http://www.hp.com/support>).

Integrated Management Log

The IML records hundreds of events and stores them in an easy-to-view form. The IML timestamps each event with 1-minute granularity.

You can view recorded events in the IML in several ways, including the following:

- From within HP SIM ("HP Systems Insight Manager" on page 63)
- From within Survey Utility
- From within operating system-specific IML viewers
 - For NetWare: IML Viewer
 - For Windows®: IML Viewer
 - For Linux: IML Viewer Application
- From within the iLO 2 user interface
- From within HP Insight Diagnostics (on page 62)

For more information, refer to the Management CD in the HP ProLiant Essentials Foundation Pack.

Array Diagnostic Utility

The HP Array Diagnostics Utility is a web-based application that creates a report of all HP storage controllers and disk drives. This report provides vital information to assist in identifying faults or conditions that may require attention. ADU can be accessed from the SmartStart CD or downloaded from the HP website (<http://www.hp.com>).

HP Systems Insight Manager

HP SIM is a web-based application that allows system administrators to accomplish normal administrative tasks from any remote location, using a web browser. HP SIM provides device management capabilities that consolidate and integrate management data from HP and third-party devices.



IMPORTANT: You must install and use HP SIM to benefit from the Pre-Failure Warranty for processors, SAS and SCSI hard drives, and memory modules.

For additional information, refer to the Management CD in the HP ProLiant Essentials Foundation Pack or the HP SIM website (<http://www.hp.com/go/hpsim>).

Component identification

Front panel components

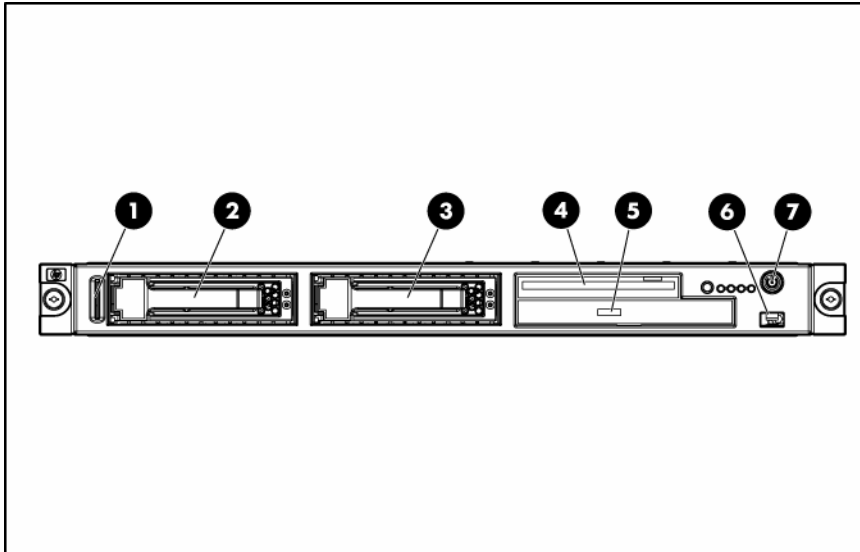

Item	Description
1	Serial label pull tab
2	Hard drive bay 1
3	Hard drive bay 2
4	Diskette drive/video connector bay
5	Optical drive bay
6	Front USB connector
7	Power On/Standby button and system power LED

Front panel LEDs and buttons

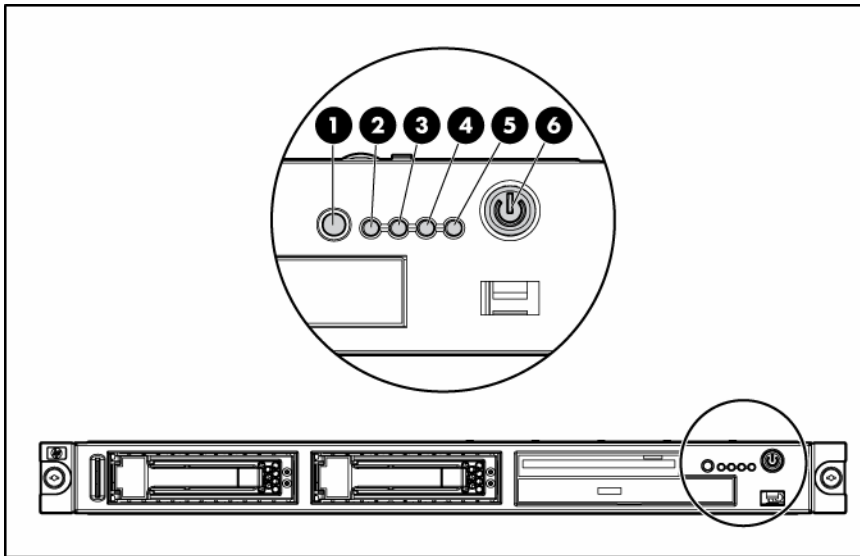

Item	Description	Status
1	UID button/LED	Blue = Identification is activated. Flashing blue = System is being remotely managed. Off = Identification is deactivated.
2	Internal health LED	Green = System health is normal. Amber = System is degraded. To identify the component in a degraded state, refer to system board LEDs. Red = System critical. To identify the component in a critical state, refer to system board LEDs. Off = System health is normal (when in standby mode).
3	NIC 1 link/activity LED	Green = Network link exists. Flashing green = Network link and activity exist. Off = No link to network exists. If power is off, view the LEDs on the RJ-45 connector for status by referring to the rear panel LEDs (on page 67).
4	NIC 2 link/activity LED	Green = Network link exists. Flashing green = Network link and activity exist. Off = No link to network exists. If power is off, the front panel LED is not active. View the LEDs on the RJ-45 connector for status by referring to the rear panel LEDs (on page 67).
5	Drive activity LED	Green = Drive activity is normal. Amber = Drive failure occurred. Off = No drive activity.

Item	Description	Status
6	Power On/Standby button and system power LED	Green = System is on. Amber = System is shut down, but power is still applied. Off = Power cord is not attached, power supply failure has occurred, no power supplies are installed, facility power is not available, or the DC-to-DC converter is not installed.

Rear panel components

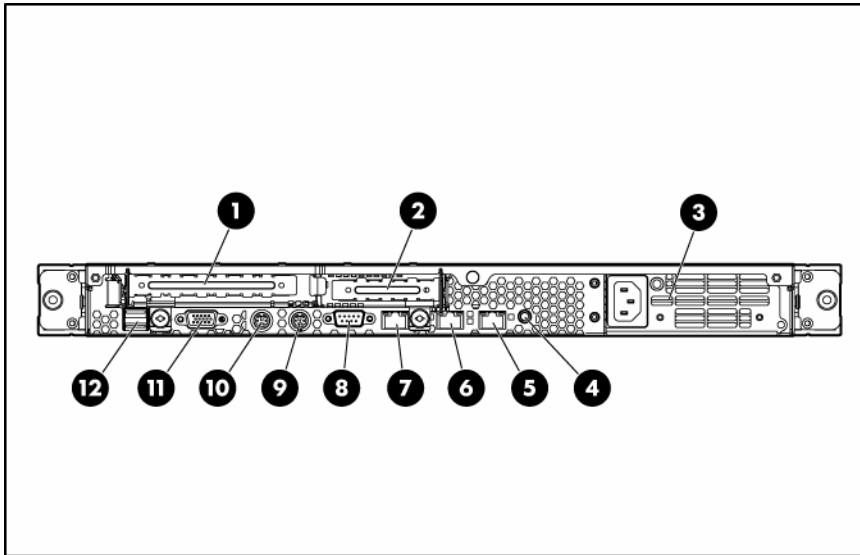

Item	Description
1	PCI Express expansion slot 2, (optional PCI-X, full-length)
2	PCI Express expansion slot 1, low-profile, half-length
3	Power supply
4	UID button/LED
5	10/100/1000 NIC 2
6	10/100/1000 NIC 1
7	iLO 2 management port
8	Serial connector
9	Keyboard connector
10	Mouse connector
11	Video connector
12	USB connectors (2)

PCI expansion slot definitions

Slot	Type	Length	Connector	Interconnect
1	PCI Express	Half	x8	x1

Slot	Type	Length	Connector	Interconnect
2	PCI Express	Full	x8	x8
	Optional PCI-X	Full	133 MHz/3.3 V	64 bit

Rear panel LEDs

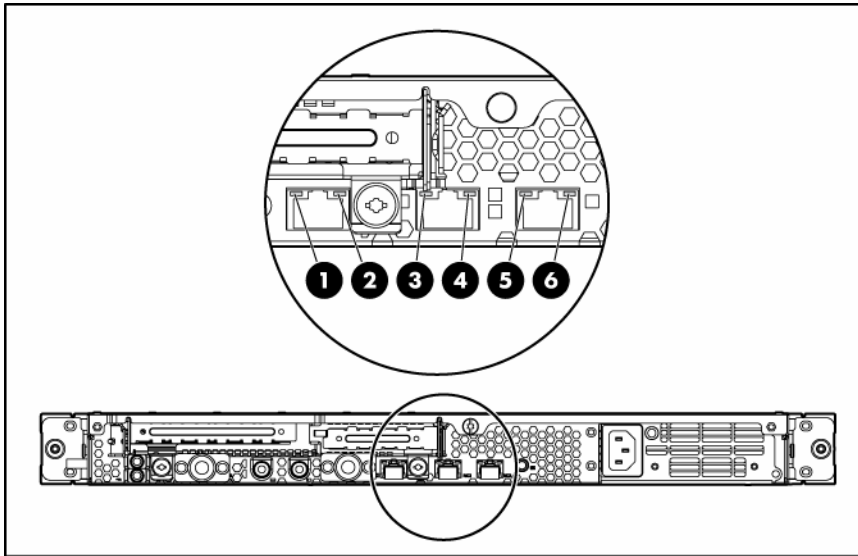

Item	Description	Status
1	iLO 2 activity	Green = Activity exists. Flashing green = Activity exists. Off = No activity exists.
2	iLO 2 link	Green = Link exists. Off = No link exists.
3	10/100/1000 NIC 1 activity	Green = Activity exists. Flashing green = Activity exists. Off = No activity exists.
4	10/100/1000 NIC 1 link	Green = Link exists. Off = No link exists.
5	10/100/1000 NIC 2 activity	Green = Activity exists. Flashing green = Activity exists. Off = No activity exists.
6	10/100/1000 NIC 2 link	Green = Link exists. Off = No link exists.

System board components

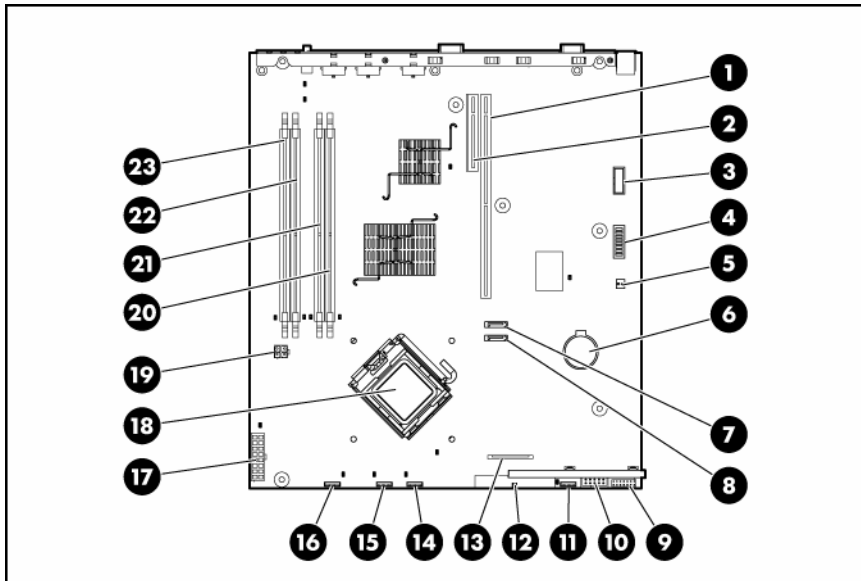

Item	Description	Item	Description
1	PCI Express x8 connector or optional PCI-X 133-MHz connector	13	Diskette drive connector
2	PCI Express x1 connector	14	Fan 3 and 4 connector
3	Video option connector	15	Fan 5 and 6 connector
4	System maintenance switch	16	Fan 7 and 8 connector
5	NMI switch	17	Main power connector
6	Battery	18	Processor socket
7	Hard drive connector 1	19	Auxiliary power connector
8	Hard drive connector 2	20	DIMM slot 1 (bank A)
9	Front panel LED board connector	21	DIMM slot 2 (bank B)
10	Front USB connector	22	DIMM slot 3 (bank A)
11	Fan 1 and 2 connector	23	DIMM slot 4 (bank B)
12	Optical drive connector	—	—

System maintenance switch

Position	Default	Function
S1	Off	Off = iLO 2 security is enabled On = iLO 2 security is disabled
S2	Off	Off = Normal operation On = RBSU will not commit any configuration changes *
S3	Off	Reserved

Position	Default	Function
S4	Off	Off = Normal operation On = Override RBSU setting and enable diskette boot *
S5	Off	Off = Power-on password enabled On = Power-on password disabled *
S6	Off	Off = Normal operation On = BIOS will clear CMOS and NVRAM *
S7	Off	Reserved
S8	Off	Reserved

* "On" activates the function.

NMI functionality

An NMI crash dump enables administrators to create crash dump files when a system is hung and not responding to traditional debug mechanisms.

Crash dump log analysis is an essential part of diagnosing reliability problems, such as hangs in operating systems, device drivers, and applications. Many crashes freeze a system, and the only available action for administrators is to cycle the system power. Resetting the system erases any information that could support problem analysis, but the NMI feature preserves that information by performing a memory dump before a hard reset.

To force the OS to invoke the NMI handler and generate a crash dump log, the administrator can do any of the following:

- Short the NMI jumper pins
- Press the NMI switch
- Use the iLO Virtual NMI feature

For additional information, see the whitepaper on the HP website

(<http://h20000.www2.hp.com/bc/docs/support/SupportManual/c00797875/c00797875.pdf>).

System board LEDs

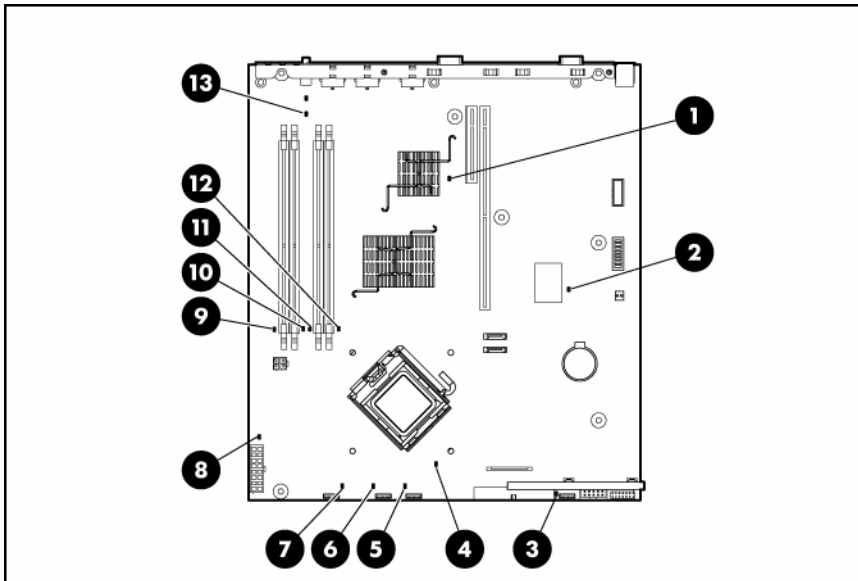

Item	LED description	Status
1	Reserved	—
2	Overtemperature	Amber = System has reached a cautionary or critical temperature level. Off = Temperature is OK.
3	Fan 1 and 2	Amber = One or more fans in this module have failed. Off = All fans in this module are operating normally.
4	Processor	Amber = Processor has failed. Off = Processor is operating normally.
5	Fan 3 and 4	Amber = One or more fans in this module have failed. Off = All fans in this module are operating normally.
6	Fan 5 and 6	Amber = One or more fans in this module have failed. Off = All fans in this module are operating normally.
7	Fan 7 and 8	Amber = One or more fans in this module have failed. Off = All fans in this module are operating normally.
8	PPM	Amber = PPM has failed. Off = PPM is operating normally.
9	DIMM 4	Amber = DIMM has failed. Off = DIMM is operating normally.

Item	LED description	Status
10	DIMM 3	Amber = DIMM has failed. Off = DIMM is operating normally.
11	DIMM 2	Amber = DIMM has failed. Off = DIMM is operating normally.
12	DIMM 1	Amber = DIMM has failed. Off = DIMM is operating normally.
13	Power on	Green = System board power is normal. Off = System board power has failed.

System LEDs and internal health LED combinations

When the internal health LED on the front panel illuminates either amber or red, the server is experiencing a health event. Combinations of illuminated system LEDs and the internal health LED indicate system status.

The front panel health LEDs indicate only the current hardware status. In some situations, HP SIM may report server status differently than the health LEDs because the software tracks more system attributes.

System LED and Color	Internal Health LED Color	Status
Processor failure (amber)	Red	One or more of the following conditions may exist: <ul style="list-style-type: none"> • Processor has failed. • Processor failed over to the offline spare. • Processor is not installed in the socket. • Processor is unsupported. • ROM detects a failed processor during POST.
	Amber	Processor is in a pre-failure condition.
PPM failure (amber)	Red	PPM has failed.
DIMM failure, slot X (amber)	Red	<ul style="list-style-type: none"> • DIMM in slot X has failed. • DIMM in slot X is an unsupported type, and no valid memory exists in another bank.
	Amber	<ul style="list-style-type: none"> • DIMM in slot X has reached single-bit correctable error threshold. • DIMM in slot X is in a pre-failure condition. • DIMM in slot X is an unsupported type, but valid memory exists in another bank.
DIMM failure, all slots in one bank (amber)	Red	No valid or usable memory is installed in the system.
Overtemperature (amber)	Amber	The Health Driver has detected a cautionary temperature level.
	Red	The server has detected a hardware critical temperature level.
Riser interlock (amber)	Red	The PCI riser board assembly is not seated.

System LED and Color	Internal Health LED Color	Status
Fan module (amber)	Amber	A redundant fan has failed.
Fan module (red)	Red	The minimum fan requirements are not being met in one or more of the fan modules. One or more fans have failed or are missing.
Power supply signal interlock (amber)	Red	The power supply signal cable is not connected to the system board.

Internal USB connector

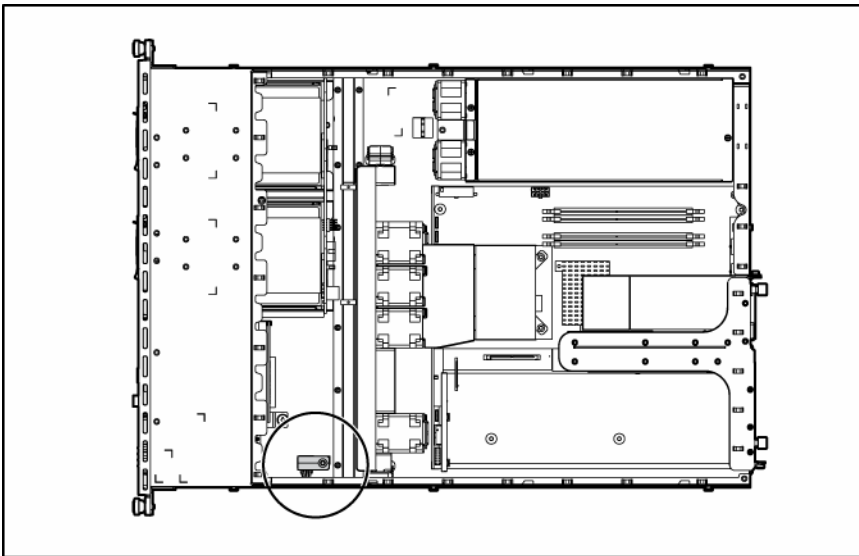

SATA and SAS device numbers

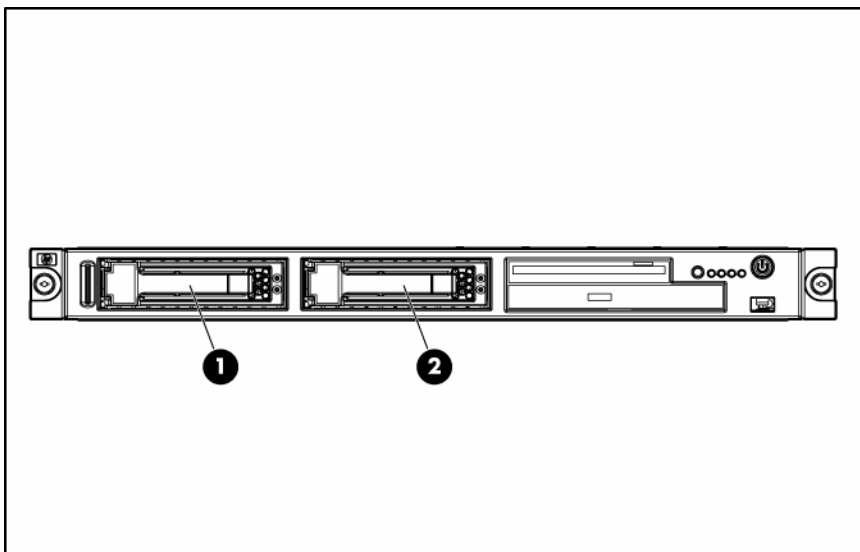

Item	Description
1	Device 1
2	Device 2

Fan assembly location

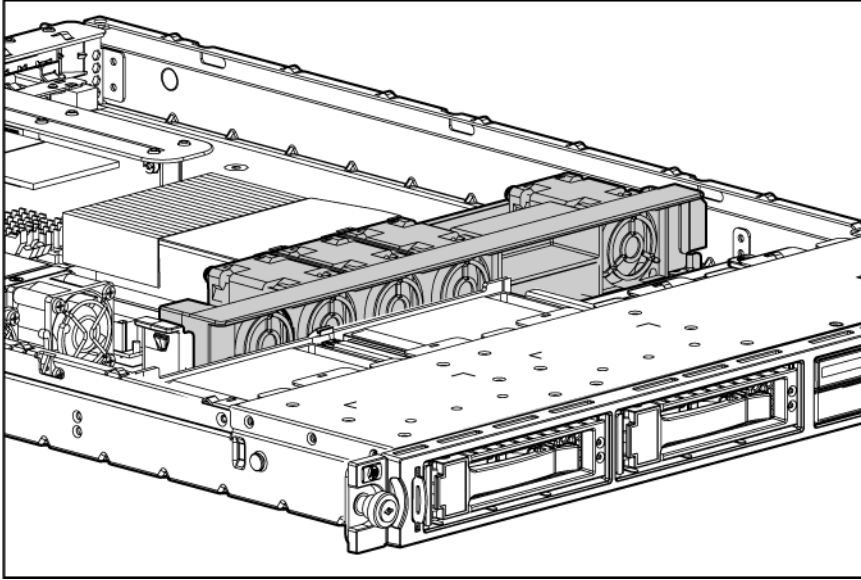

Specifications

Environmental specifications

Specification	Value
Temperature	
Operating ¹	10°C to 35°C (50°F to 90°F)
Non-operating	30°C to 60°C (-22°F to 140°F)
Maximum rate of temperature change	
Operating ^{2,3}	10°C/hr (18°F/hr)
Non-operating	20°C/hr (36°F/hr)
Relative humidity (noncondensing)**	
Operating	10% to 90%
Non-operating	5% to 95%
Maximum wet bulb temperature (non-condensing)	
Operating	28°C (82.4°F)
Non-operating	38.7°C (101.7°F)
Altitude	
Operating ²	3,050 m (10,000 ft)
Non-operating	9144 m (30,000 ft)
Maximum rate of altitude change	
Operating	457 m/min (1,500 ft/min)
Non-operating	457 m/min (1,500 ft/min)

¹ All temperature ratings shown are for sea level. An altitude derating of 1°C per 300 m (1.8°F per 1,000 ft) to 3048 m (10,000 ft) is applicable. No direct sunlight allowed.

² The type and number of options installed can limit the upper limit.

³ System performance may be reduced if operating with a fan fault above 30°C (86°F).

Server specifications

Specification	Value
Dimension	
Height	4.32 cm (1.70 in)
Depth	60.96 cm (24 in)

Specification	Value
Width	42.62 cm (16.78 in)
Weight (maximum)	12.27 kg (27.0 lb)
Weight (no drives installed)	10.91 kg (24.0 lb)
Input requirement	
Rated line voltage	90 VAC to 264 VAC
Rated input frequency	47 Hz to 63 Hz
Rated input current	6.0 A (100 to 120 VAC) to 3.0 A (200 to 240 VAC)
Rated input power	486 W at 115 V (assume 350 W output) 479 W at 230 V (assume 350 W output)
BTUs per hour	1710
Power supply output	
Rated steady-state power	420 W
Acoustic noise*	
Sound power, L_{WA_d}	
Idle	≤ 6.22 Bels
Operating	≤ 6.3 Bels
Bystander sound pressure, L_{pAm}	
Idle	≤ 44.1 dBA
Operating	≤ 44.9 dBA

*The limits apply when operated in an ambient environment temperature of $+23^{\circ}\text{C} \pm 2^{\circ}$ ($+73.4^{\circ}\text{F} \pm 2^{\circ}$).

Acronyms and abbreviations

ACU

Array Configuration Utility

ADU

Array Diagnostics Utility

BBWC

battery-backed write cache

BIOS

Basic Input/Output System

CMOS

complementary metal-oxide semiconductor

CSR

Customer Self Repair

DDR2

double data rate-2

ECC

error checking and correcting

iLO 2

Integrated Lights-Out 2

IML

Integrated Management Log

NIC

network interface controller

NMI

non-maskable interrupt

NVRAM

non-volatile memory

PCI

peripheral component interface

PCI-X

peripheral component interconnect extended

PCIe

peripheral component interconnect express

POST

Power-On Self Test

RBSU

ROM-Based Setup Utility

SAS

serial attached SCSI

SATA

serial ATA

SDRAM

synchronous dynamic RAM

UID

unit identification

USB

universal serial bus

Index

A

access panel 16
ADU (Array Diagnostic Utility) 63
air baffle 29
Array Diagnostic Utility (ADU) 63

B

battery 19, 56, 68, 69
battery-backed write cache battery holder 31
battery-backed write cache battery pack 31
bezel, front 16, 37
bezel, server 16, 37
blue screen event 69
buttons 64

C

cable management arm 19
cables 19, 58, 59
cabling 58, 59, 60, 61
cautions 25
CD-ROM drive 19
component identification 64, 68, 69
components 16, 62, 64
components, mechanical 16
components, system 19
connectors 64
controller 40, 58, 59
crash dump analysis 69
CSR (customer self repair) 5
customer self repair (CSR) 5

D

device numbers 72
diagnostic tools 62
diagnostics utility 62
DIMM installation guidelines 42
DIMM slot LEDs 70
DIMM slots 68
DIMMs 19, 42, 43
diskette drive 19, 34, 64
diskette drive cable 19, 58

diskette drive connectors 68
drive bays 64
DVD±RW drive 19
DVD-ROM drive 19

E

electrostatic discharge 23
environmental specifications 74
expansion board 39, 58, 59
expansion slots 66
extending server from rack 25
external health LED 65

F

fan assembly 19, 30, 73
fan connectors 68
fan LED 70
fans 73
features 64
front bezel 16, 37
front panel components 64
front panel LEDs 65
front panel/LED board connector 68
front video connector 35

H

hard drive backplane 23, 28
hard drive blanks 28
hard drive cable 19, 58, 59
hard drive connector 68
hard drive, replacing 27
hard drives 27, 64
health LEDs 65, 69
heatsink 19, 44
HP Insight Diagnostics 62
HP ProLiant Essentials Foundation Pack 63
HP Systems Insight Manager, overview 63

I

illustrated parts catalog 16
IML (Integrated Management Log) 63
Insight Diagnostics 62

Integrated Management Log (IML) 63
interleaving memory configuration 43
internal health LED 65, 71
internal USB connector 72

L

LED, DIMM slot 70
LED, drive activity 65
LED, fan 70
LED, iLO NIC 67
LED, overtemperature 70
LED, power on 70
LED, PPM 70
LED, processor 70
LED, UID 65
LEDs 64
LEDs, NIC 67

M

management tools 62
mechanical components 16
media cage 19, 32
memory 19, 42, 43
memory dump 69

N

NIC LEDs 65, 67
NMI switch 68, 69
non-interleaving memory configuration 43

O

operating system crash 69
optical drive 33
optical drive cable 19, 58
optical drive connector 68
overtemperature LED 70

P

part numbers 16
PCI expansion slot definitions 66
PCI Express connector 68
PCI Express riser boards 19, 41
PCI riser board assembly 19, 39
PCI-X riser board 19, 41
plastics kit 19
power button/LED board 19, 36
power connectors, internal 68
power cord 19

power LEDs, system 65
power on LED 70
Power On/Standby button 26, 64, 65
power supplies 19, 43
power supply LEDs 71
powering down 26
PPM failure LEDs 71
PPM LED 70
processor 19, 42, 46
processor failure LEDs 70
processor LED 70
processor socket 68

R

rack warnings 24
rear panel components 66
rear panel LEDs 67
removal and replacement procedures 23
resetting the system 69

S

safety considerations 23
safety information 23
SAS backplane 19, 28
SAS hard drive 19
SATA backplane 19, 28
SATA hard drive 19
serial connector 68
serial label pull tab 37, 64
server specifications 74
spare part numbers 16, 19
specifications 74
specifications, environmental 74
specifications, server 74
static electricity 23
storage controller 40, 59
switch, NMI 68, 69
switches 68, 69
symbols on equipment 23
system board 19, 50
system board battery 68
system board LEDs 71
system maintenance switch 68, 69
Systems Insight Manager 63

T

tools 23, 62

U

UID LED 26, 65, 69

USB connectors 64, 68, 72

utilities 62

V

video connector 35, 64, 68

W

warnings 25

warranty 5, 16