

MONESSEN HEARTH SYSTEMS

36" and 42" FACTORY-BUILT WOOD BURNING FIREPLACES FOR MANUFACTURED HOMES INSTALLATION AND OPERATING INSTRUCTIONS



MODELS
BWBC400MHB
BWBC500MHB

FACTORY-BUILT FIREPLACES U.L. FILE NO. MH7603

These fireplaces have been tested to U.L. Safety Standard 127, and listed by Underwriters Laboratories, Inc. Look for the UL listing mark on your fireplace.

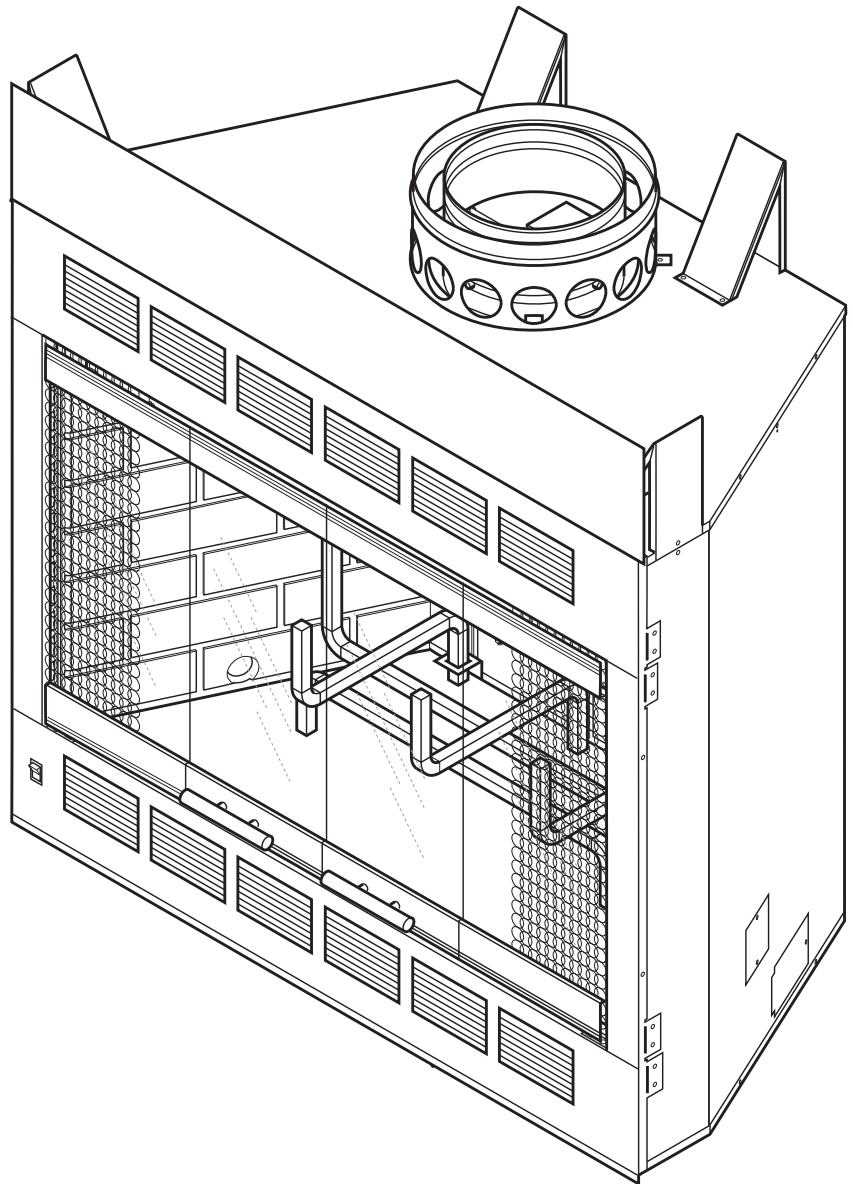

CONGRATULATIONS!

You have chosen the finest wood burning fireplace available. Your fireplace has been designed for years of heating and viewing enjoyment. Please take time to read this entire manual before installing or operating your fireplace.

READ BEFORE INSTALLING. SAVE THESE INSTRUCTIONS

CONTENTS

Listing and Code Approval	2	Glass Door Installation	24
Important Safety Information	3	Removing Glass Doors	24
Fireplace Usage	4	Replacing a Glass Panel.....	25
Product Features	5	Reinstalling Glass Door	26
How This Fireplace Works	6	Fireplace Operation	27
Fireplace Location	8	Advantages of a Wood Burning Fireplace	27
Fireplace Dimensions	9	Which Woods Are Best	27
Fireplace Installation	9	Disposal of Ashes	27
Safety Strip Installation	10	Building and Tending a Fire	28
Hearth Extension	10	Wood vs. Fossil Fuels.....	28
Unpacking Fireplace	12	Glass Doors	29
Clearances	12	Maintenance	30
Chimney Installation	14	Fireplace Maintenance.....	30
Installing Chimney Safety Information	14	Glass Door Maintenance	30
Firestop and Chimney Installation.....	15	Refractory Components Maintenance	31
Elbow Installation	17	Chimney Maintenance	32
Offset Installation Sequence	18	Checklist of DOs and DON'Ts.....	33
Chimney Cap Installation	19	Replacement parts	34
Outside Combustion Air	21	Warranty	Back Cover
Precautions and Recommendations	21		
Model AK6A Combustion Air Assembly.....	21		
Trim and Mantel Installation for Wood Burning			
Fireplaces	22		
Locating Front and Side Clearances.....	22		
Locating Mantel.....	23		
Fan Assembly	23		

LISTING AND CODE APPROVALS

The UL listing mark on the fireplace indicates that the fireplace is listed by Underwriters Laboratories, Inc., to U.L. 127 Safety Standard For Factory-Built Fireplaces. The design of this fireplace and these instructions complied with the applicable U.L. 127 safety standards for a factory-built fireplace in effect at the time the fireplace was manufactured. You should be aware, however, that failure to properly install, operate, and maintain this or any other factory-built fireplace can result in a home fire or other occurrences that could cause deaths, injuries, and property damage. It is very important that the persons installing and/or supervising the installation of this fireplace have appropriate skills in using the tools and techniques required; and reading and comprehension skills sufficient to read and follow these instructions.

These instructions contain warnings, cautions, and notes to emphasize important safety information. To assure that safe and satisfactory service is received from this fireplace, please read all contents of this manual. The instructions contained in this manual are in compliance with the requirements of the Department of Housing and Urban Development (HUD) "Manufactured Home Construction and Safety Standards", and the National Fire Protection Association Safety Standard 211. Before beginning the fireplace installation, you should check with local building officials to obtain required permits and assure compliance with local regulations and codes. If you encounter problems with code requirements, contact your dealer for assistance.

IMPORTANT SAFETY INFORMATION

INSTALLER

Please leave these instructions with the owner.

OWNER

Please retain these instructions for future reference.

WARNING

- Read these instructions entirely before beginning any part of the installation. Save these instructions for any future repairs.
- Use these instructions as a guide during the installation of the fireplace.
- Install all the parts used with this fireplace system in accordance with these installation instructions. Failure to do so may be hazardous and will void the warranty.
- Do not alter fireplace and accessories in any way that is not specifically recommended in this manual.
- Do not install fireplace with a masonry flue.
- Do not pack required air spaces with combustible material or insulation not specifically recommended for use in such areas.
- When installed in a manufactured home, this fireplace must be equipped with glass doors and accessories for supplying outside air for combustion.
- **WARNING: DO NOT INSTALL IN SLEEPING ROOM OF A MANUFACTURED HOME.**
- This fireplace and chimney should not be used for venting a wood or coal burning heater or fireplace insert.

CAUTION

Do not use a fireplace insert or other product not specified for use with this fireplace.

WARNING

Improper installation or use of this fireplace will void its warranty and can cause:

- Damage to the fireplace from overheating.
- Hazardous temperatures to develop on combustible materials adjacent to the fireplace or chimney.
- The emission of smoke, sparks or hazardous gases into the dwelling.
- Leakage of rain water into the dwelling.

FIREPLACE USAGE

These fireplaces are for use in manufactured homes. Burn solid wood fuel only or use only with one of the gas log appliances described below. These fireplaces are intended for supplemental heating only and are not intended for use as a primary heating system.

These fireplaces are designed to sit directly on a combustible floor. Except as noted by this instruction manual, only parts manufactured by Monessen Hearth Systems, and labeled for use with these specific fireplaces should be used in the installation and operation of these fireplaces. The use of improper parts in the installation and operation of these fireplaces can be hazardous and voids the warranty.

WARNING

Do not use this fireplace and chimney for venting a solid fuel heater or fireplace insert unless written authorization is given by Monessen Hearth Systems. Failure to heed this warning may cause a fire hazard and will void the Monessen Hearth System Warranty.

NOTICE

These fireplaces have provision for a gas line connection. The provision for a gas line is intended only for connecting one of the gas appliances (gas log sets) described by the following paragraph.

Install only gas log sets which have been tested and certified for installation in these fireplaces in an aftermarket (completion of sale, not for purpose of resale from the manufacturer) manufactured home, where not prohibited by state or local codes.

These gas log sets...

have an automatic shutoff device;

comply with applicable standards for gas appliances;

have been tested and certified by a nationally recognized organization for installation in these specific fireplaces.

NOTICE

These fireplaces have been found to comply with the standard for factory-built fireplaces, UL 127, when installed with unvented gas logs sets. However, state or local codes may only allow operation of gas log appliances in a vented configuration. Check your state or local codes.

CAUTION

When using a decorative gas log appliance in these fireplaces, the fireplace damper must set in the fully open position. Note: A gas log appliance classified as decorative is not thermostatically controlled, must be vented and its primary function lies in the esthetic effect of the flame.

CAUTION

If a gas appliance is installed in one of the fireplaces, installation must be in accordance with nation fuel gas code ANSI Z223.1 Guidelines for safely installing and operating one of the gas appliances (gas lot set) described above are contained in the instructions provided with the gas appliance. The installer of the gas appliance must describe the operation of the fireplace and gas appliance to the individuals who will be operating them. Instruction manuals must be left with operator of the system.

CAUTION

While a gas log appliance is installed in one of these fireplaces, solid fuels must not be burned in the fireplace.

PRODUCT FEATURES

PRODUCT SPECIFICATIONS

- This fireplace is designed to burn solid wood fuel (wood), UL-classified processed solid fuel fire logs, or a certified decorative gas appliance may be installed in the fireplace as described later by this instruction manual.
- The appliance must be properly connected to a venting system.

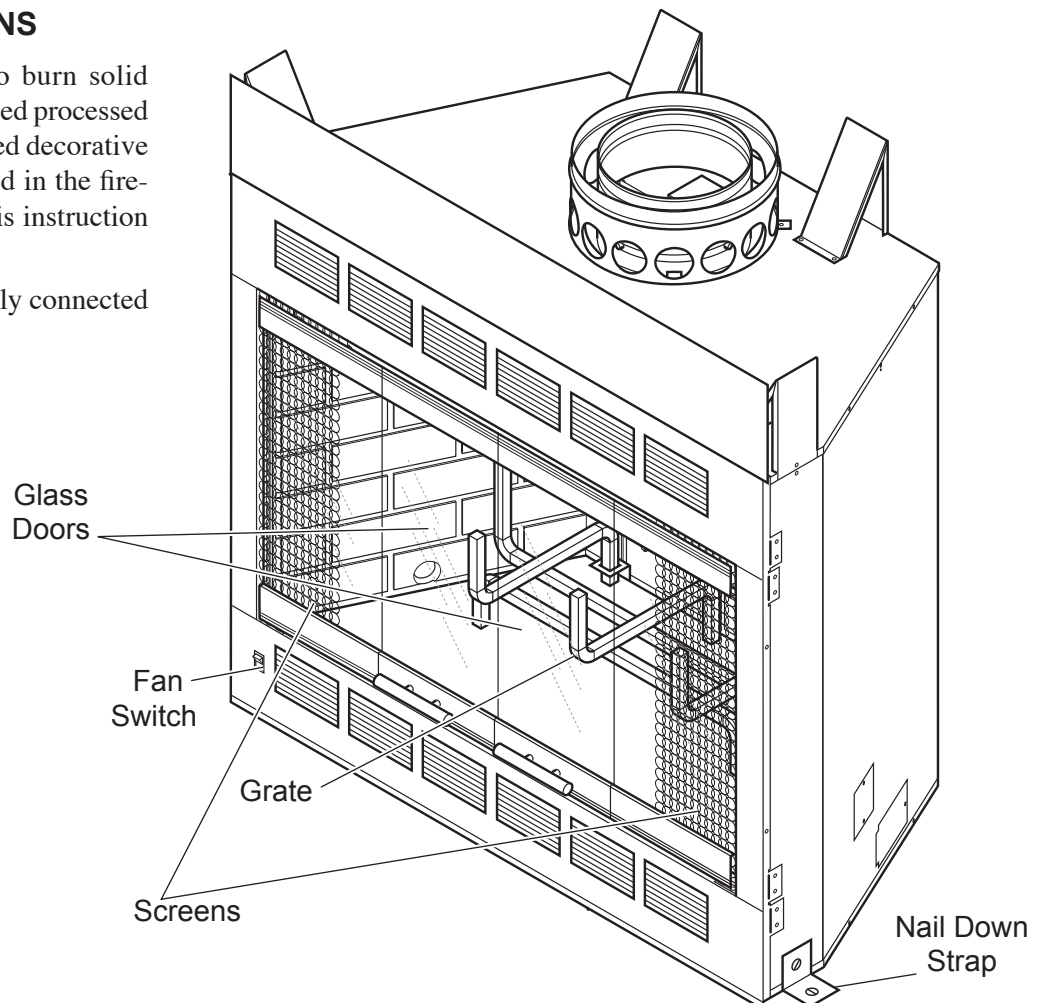

Figure 1 - BWBC400/500MHB

HOW THIS FIREPLACE WORKS

As wood is burned in the firebox, room air enters the fireplace through its “cool air inlet”, circulates around the firebox, and exits the fireplace through its “warm air outlet.” See *Figure 2*. This air circulation cools the firebox.

WARNING

Do not block or restrict air circulation in any manner. Blocking or restricting the air flow will cause the firebox to reach hazardous temperatures.

WARNING

The fireplace will go through a curing process (burning off oil residue, etc.) the first few times it is fired. Smoke and fumes may be emitted from its upper grille. Open a door or window to let any smoke or fumes escape during curing period.

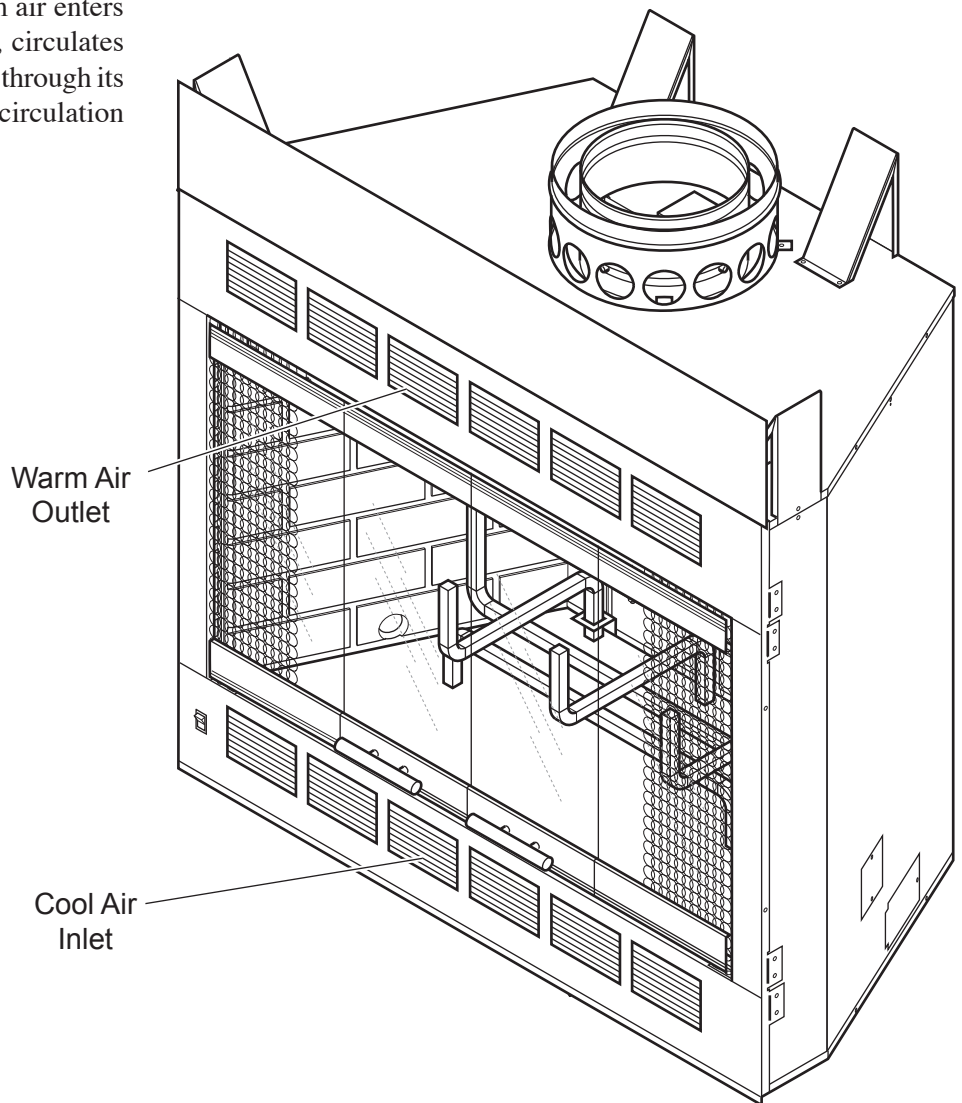

Figure 2 - Location of Cool Air Inlet and Warm Air Outlet

HOW THIS FIREPLACE WORKS

For large fires, the maximum heating benefit from the fireplace will be obtained with its glass doors fully open. The open doors will allow more radiant heat to be emitted out of the front opening of the fireplace. **When the glass doors are open, close the fireplace's mesh screens to help keep burning embers from popping out of the firebox.** With a small fire, it is best to operate the fireplace with its glass doors fully closed to prevent excessive room air from being drawn up the chimney. To prevent room air from escaping up the chimney overnight, close the fireplace glass doors before retiring in the evenings.

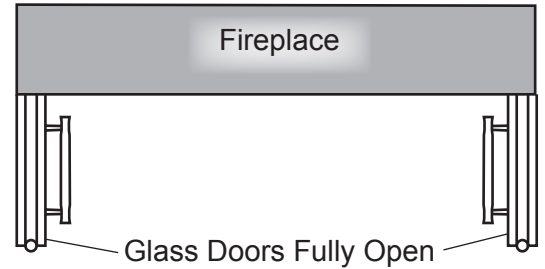

Figure 3 - Correct Position

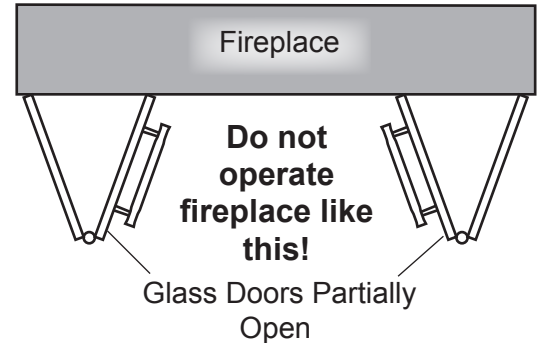

Figure 4 - Incorrect Position

WARNING

The fireplace should be operated only with its glass doors fully open or fully closed. If glass doors are left partially open, gas and flame may be drawn out of fireplace opening. This creates risks of both fire and smoke. See Figures 3 and 4.

With the provided AK6A combustion air kit installed on the fireplace, outside combustion air may enter the firebox through a dampered opening located on the left side of the fireplace. This feature reduces the room air used for combustion and prevents excessive heat loss from the room. **When the fireplace is in use, this damper should be open.** When the fireplace is not in use, the damper may be closed to prevent cold air from entering the firebox. The outside combustion air control lever is located inside the fireplace firebox just above the brick panel on the left side of the firebox as shown by Figure 5.

NOTE: Outside combustion air damper is open when its control lever is up. The damper is closed when its control lever is down.

The fireplace must be supplied with outside combustion air when the fireplace is installed in a manufactured home. See the *Outside Combustible Air* section of this manual for additional information about outside combustion air.

This fireplace is equipped with a factory-installed fan assembly to help circulate heat produced by the fireplace. The fan's ON/OFF rocker switch is installed in the left side of the lower louver panel on the front of the fireplace. Use the ON/OFF rocker switch to turn the fan on and off as desired for heat circulation. See the *Wiring for Fan Assembly*, page 27 of this manual for additional information about fan assembly.

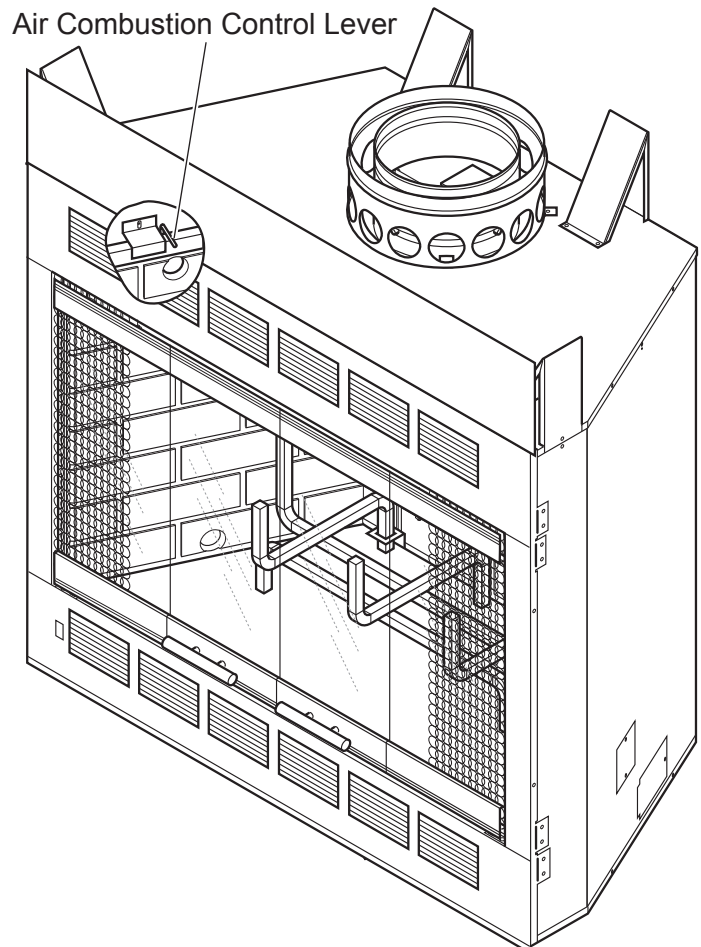

Figure 5 - Outside Combustion Air Control Lever Location

FIREPLACE LOCATION

The following factors should be taken into consideration:

- This fireplace should have sufficient access for its safe operation and maintenance.
- The SVTR firestop thimble allows chimney to be passed between joist and rafters or trusses placed 16" on center. *See Chimney Installation, page 14.*
- Locate a position where the flue system of the fireplace can be properly installed without damaging the integrity of the building. e.g. cutting wall or ceiling joist (example: load-bearing framing members).
- Install floor protection when the appliance is installed directly on tile or other combustible material.
- No special foundation is needed for this fireplace. If fireplace is trimmed with large stone or brick facing, make sure the foundation will support those materials.
- Check fireplace and flue system clearance requirements.
- Locate the fireplace in a large and open room that is centrally located in the house. This will optimize heat circulation and comfort.
- Locate fireplace away from frequently opened doors, central heat outlets or returns, or other places where air movements may disturb the airflow around the fireplace.

CAUTION

Do not install fireplace over carpeting.

Note: Air turbulence near the fireplace may cause smoke to spill out of the fireplace opening.

- Locate fireplace near a load bearing wall. Make sure the support structure is strong enough or reinforced if fireplace is to be trimmed with a heavy stone or brick facing and hearth extension.
- This fireplace may be installed along a wall, across a corner, or use an exterior chase. *See Figure 6 for suggested locations.*
- Location should be out of high traffic areas and away from furniture and draperies.
- Never obstruct the front opening of the fireplace.
- Do **not** install in the vicinity where gasoline or other flammable liquids are stored.
- *See Chimney Installation, pages 14 through 20* for allowable venting configurations.
- Minimum clearances to combustibles, side-wall, ceiling, woodwork, and windows must be maintained. *See Clearances, page 13 and 14.*

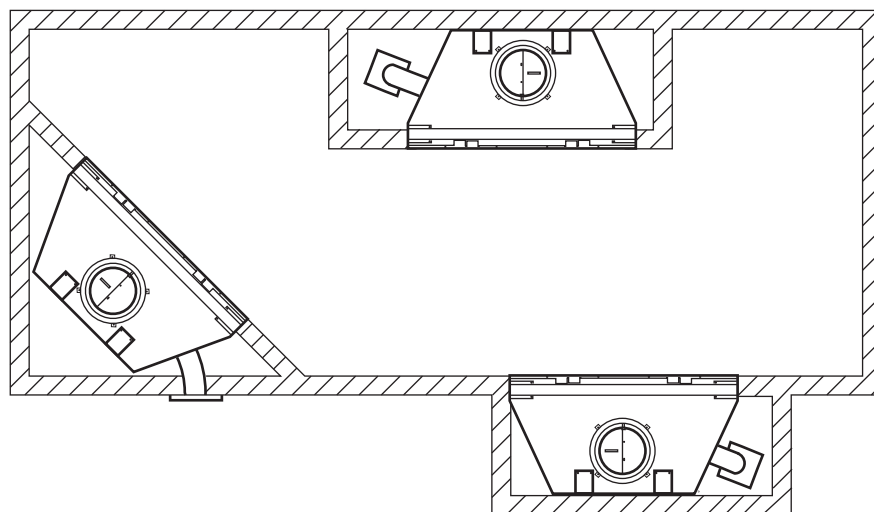

Figure 6 - Suggested Fireplace Locations

FIREPLACE DIMENSIONS

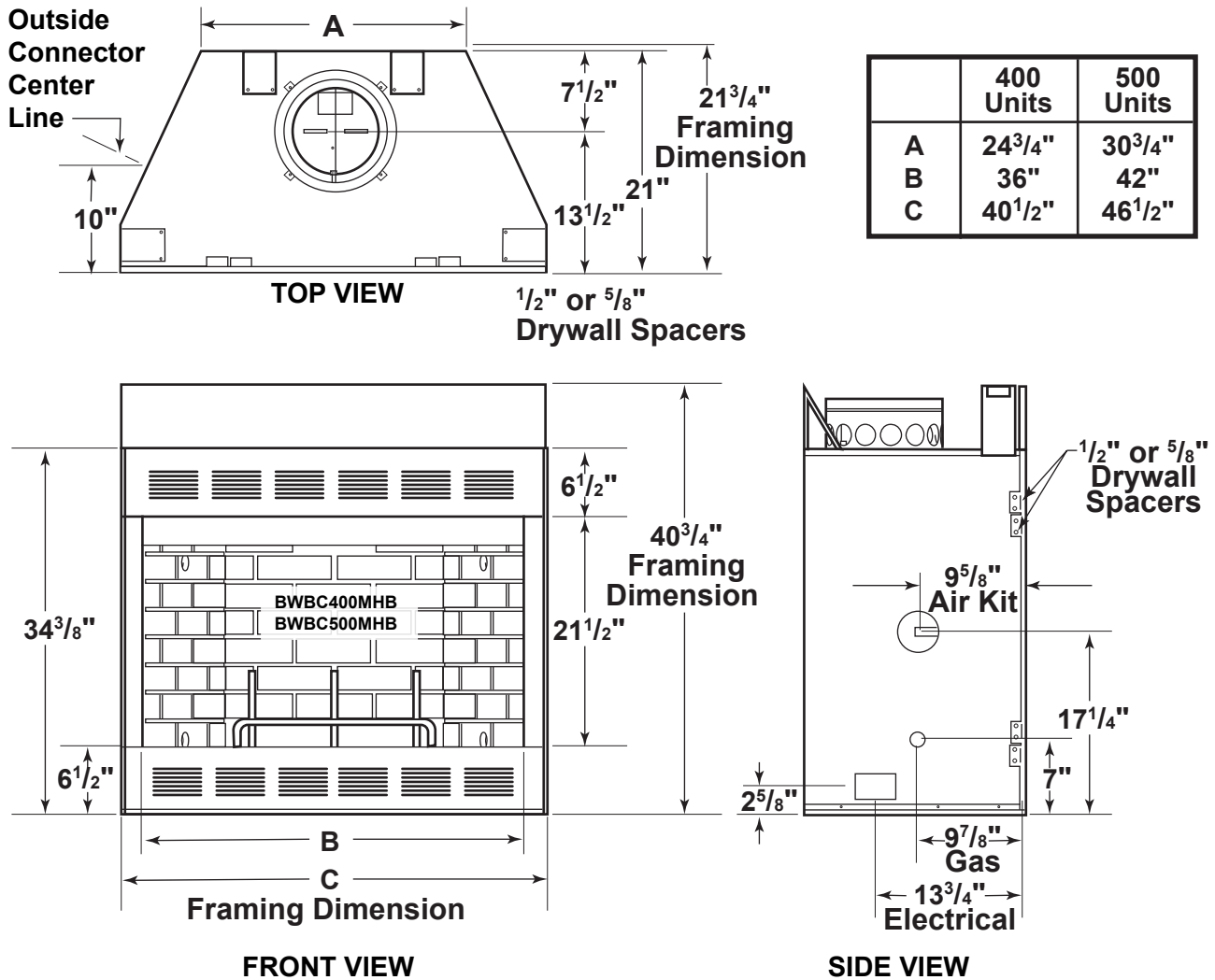

Figure 7 - Fireplace Dimensions

FIREPLACE INSTALLATION

1. Place fireplace in the desired location. Securely support and level fireplace. Check face of the fireplace with a carpenter's level. If fireplace is not plumb, correct it by placing shims under the edges of fireplace.
2. Block in the fireplace to prevent any shifting of firebox. Secure fireplace with naildown straps located on each side of the fireplace. *See Figure 1, Page 5.* Do not enclose the fireplace until the combustion air duct and chimney pipes are installed.
3. Connect fireplace fan assembly to home's electrical system.
4. Trim and enclose fireplace.
5. Install hearth extension or equivalent. *See pages 10 and 11.*

Note: Some local codes may require electrically grounding the fireplace and chimney.

FIREPLACE INSTALLATION

SAFETY STRIP INSTALLATION

You must place the metal safety strip (packed with your fireplace in two pieces) beneath the fireplace front before installing hearth extension Slide safety strip approximately 1½" under the fireplace. The hearth extension will install on top of the safety strip. See Figures 8 and 9.

HEARTH EXTENSION

For manufactured home installations, use the Model H1652 (400 unit) or Model H2066 (500 unit) hearth extension or an equivalent hearth extension* acceptable to the authority having jurisdiction. The hearth extension must cover an area 16" (400 unit) or 20" (500 unit) in front of, and 8" either side of the fireplace opening. See Figures 8 and 9. If a raised hearth extension is desired, the fireplace must be elevated accordingly and positioned on a platform constructed of combustible or noncombustible materials.

The hearth extension may be covered with tile or any noncombustible material. The hearth extension assembly must not block lower louvered panel.

Note: Do not install hearth extension until after fireplace and chimney have been installed.

Hearth Extension Clearances & Width		
	400 Unit	500 Unit
On Both Sides	8" Min.	8" Min.
Front of Fireplace	16" Min.	20" Min.
Extension Width	52"	66"

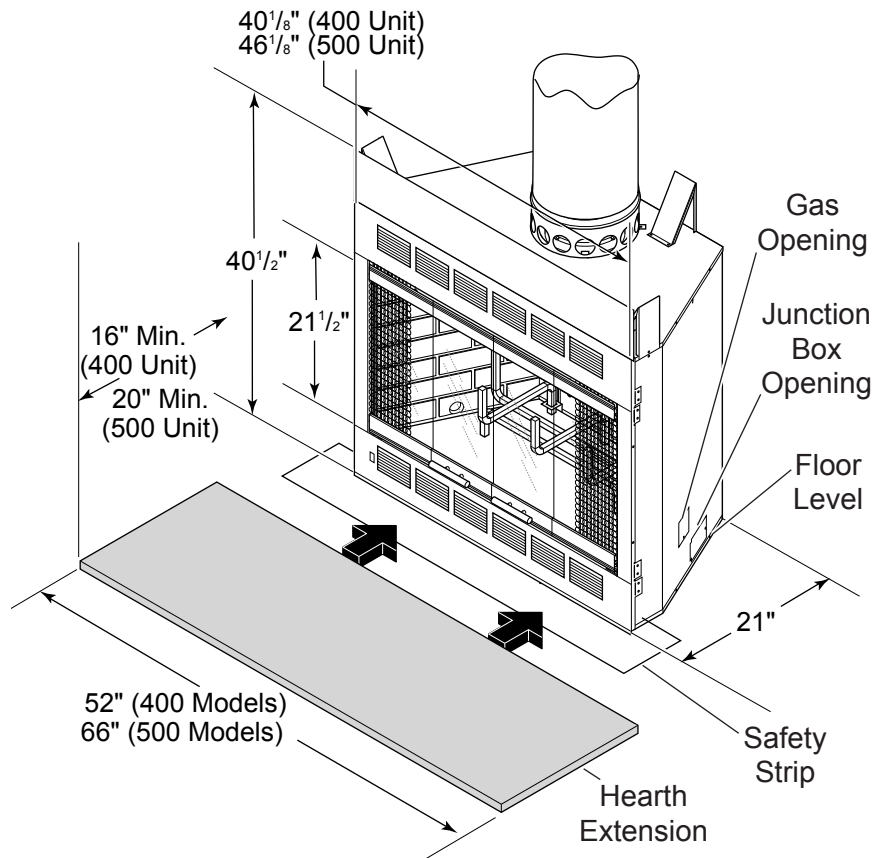

Figure 8 - Installing Hearth Extension

*HEARTH EXTENSION EQUIVALENTS

Hearth extensions are made of a 1/2" thick piece of **MICORE CV230 fiberboard covered with a sheet of 26 gauge galvanized steel. You may purchase these materials locally to fabricate hearth extensions. You can construct hearth extensions from any noncombustible material that is 1/2" thick with a "K" value (thermoconductivity) of 0.43 or lower.

For example, an insulating material 1/2" thick with a "K" value of 0.35 would be acceptable. A hearth extension made from materials 1/2" thick with a "K" value of 0.43 or lower is equal to the H1652 or H2066 hearth extensions. See Figure 8, page 10.

**MICORE CV230 is manufactured by U.S. Gypsum Corporation.

The following relations could be useful:

C = K divided by the material thickness

(Example C = .43 divided by 1/2 (.50)

C = .86)

K = C multiplies by the material thickness

(Example K = .86 multiplied by 1/2 (.50)

K = .43)

R = The material thickness divided by K

(Example R = 1/2 (.50) divided by .43

R = 1.16)

C = Thermal Conductant

R = Thermal Resistance

WARNING Only install metal safety strip horizontal to the fireplace.

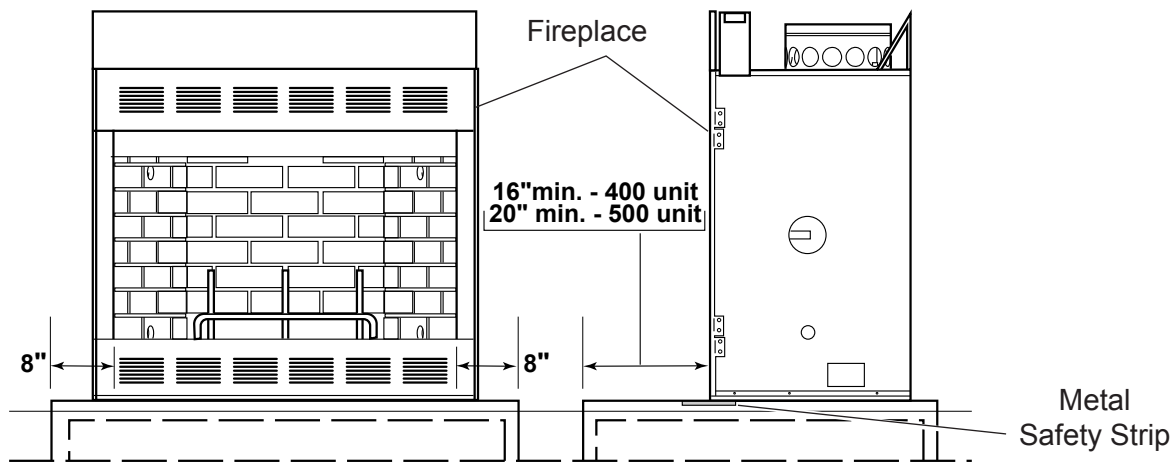

Figure 9 - Installing Hearth Extension and Metal Safety Strip

FIREPLACE INSTALLATION

UNPACKING FIREPLACE

Unpack and check the fireplace and chimney for damage. If any items are been damaged or missing, contact your Monessen Hearth Systems dealer. Do not substitute parts. Use only parts listed for use with Monessen Hearth Systems Models BWBC400MHB and BWBC500MHB fireplaces.

CLEARANCES

Provide required clearances shown in *Figures 10 through 12*. Provide 2" minimum chimney air space clearance to combustibles.

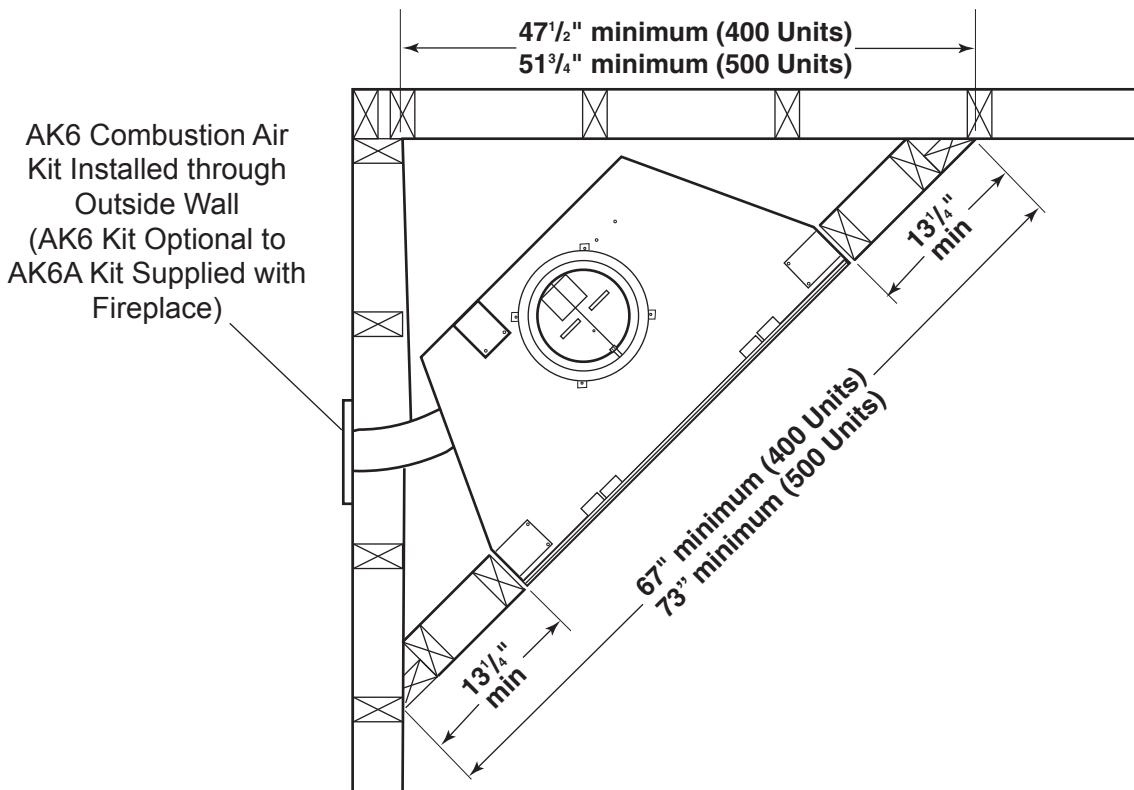

Figure 10 - Minimum Clearances for Corner Installation

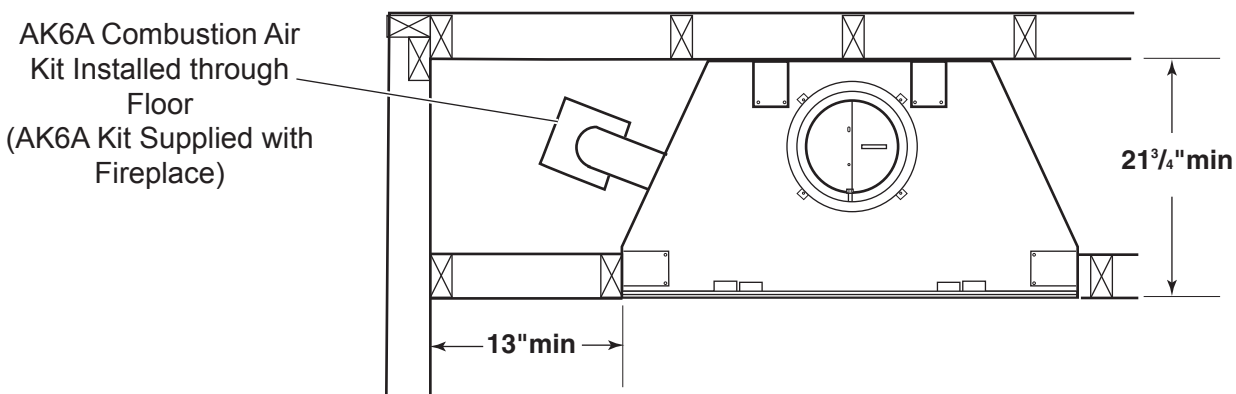

Figure 11 - Minimum Clearances for Side Wall Installation

CLEARANCES (CONTINUED)

WARNING

- You must use Model SVTR Thimble
- It is recommended for safety and reducing heat loss that firestopping be used at the ceiling level for chase installation even if local codes do not require firestopping.
- Do not insulate chase with blown or fill type insulation. Only allow insulation to come into contact with fireplace at points where fireplace would normally be contacted by framing materials.
- Combustible materials must not be installed below top spacers.
- Non-combustible materials must not cover warm air outlet and/or cool air inlet.

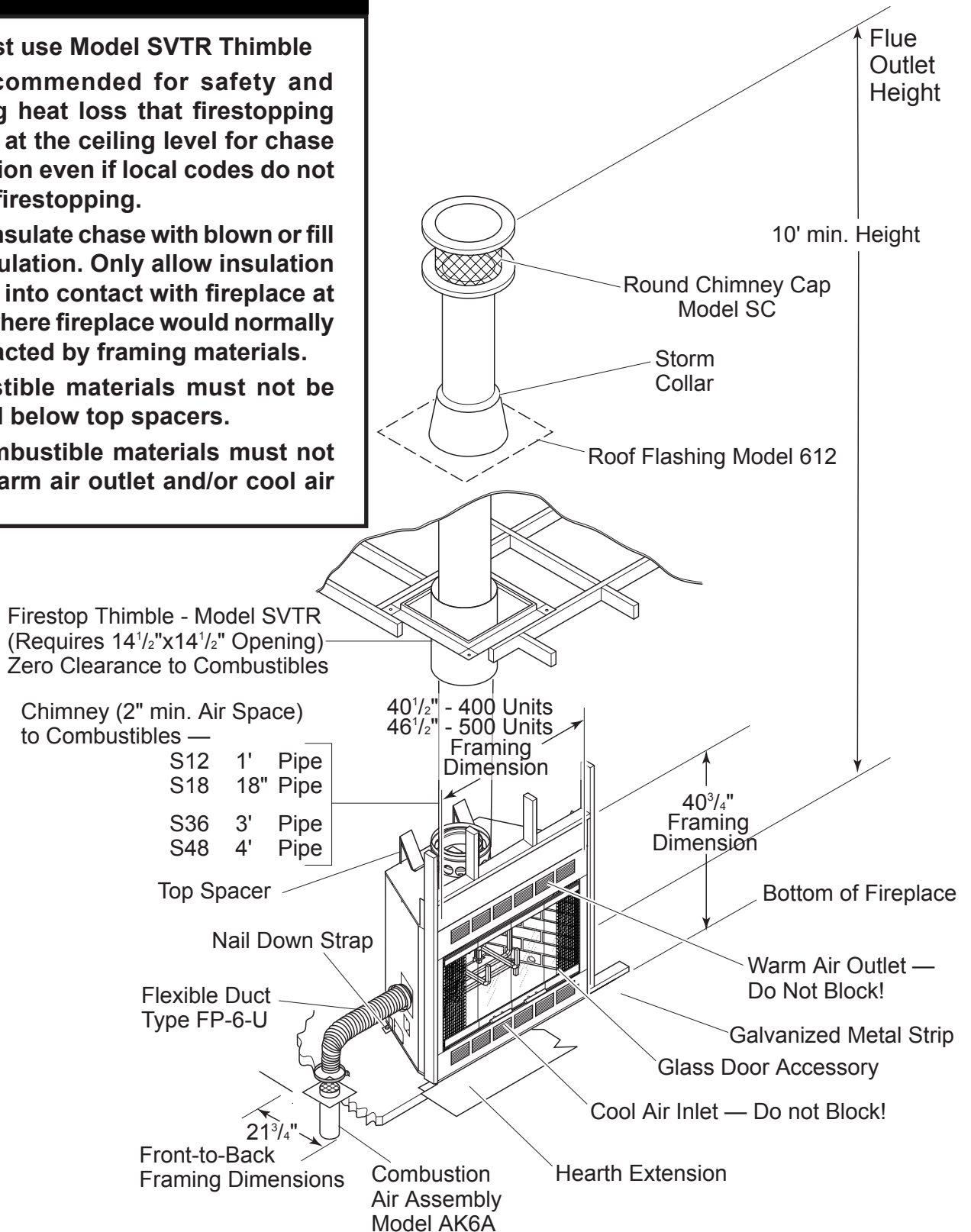

Figure 12 - Proper Clearances and Chimney Height

CHIMNEY INSTALLATION

INSTALLING CHIMNEY SAFETY INFORMATION

You must properly install the chimney to assure safe and satisfactory performance of the fireplace. This is an important part of the installation. Review the Chimney Installation Section thoroughly.

SMH Chimney Kit and SMH2 Chimney Kits are used most often in contemporary fireplace installations. If you plan to use the SMH or SMH2 Chimney Kit, check to make sure you have all parts. If you are missing any parts, contact dealer where you bought fireplace.

	Quantity for SMH Chimney Kit	Quantity for SMH2 Chimney Kit
612 flashing	1	1
SC chimney cap with storm collar	1	1
S36 chimney sections	3	2
SVTR thimble	1	1
S18 chimney sections	0	2

WARNING	For your safety, some of the important things to remember in regard to chimneys are listed below:
	<ul style="list-style-type: none">• Use only parts and accessories labeled for use with this fireplace.• Use only undamaged parts and accessories.• Enclose the chimney where it passes through the living spaces to prevent contact with and possible damage to the chimney.• There must be least 2" of air space separating all chimney sections from combustible materials THROUGHOUT THE CHIMNEY SYSTEM.• Install firestop spacers at ceiling level.• Install the proper chimney cap or chimney housing on the chimney to prevent the entry of rain and debris into the chimney and to assure the proper venting of smoke.

Note: To select the proper chimney height, see Figures 12 through 15. The flue outlet must be a minimum of 3' above the highest point where the chimney penetrates the roof and a minimum of 2' above all portions of the building within ten feet. If the chimney is to include elbows to offset the chimney, see Chimney Offset and Cap Installation Section. There must be at least 2" air space between all sections of the chimney and combustible materials between floors.

Do not extend the chimney more than 90" above the roof without additional support.

FIRESTOP THIMBLE AND THIMBLE EXTENSION

A firestop thimble is required in the chimney installation of all fireplaces safety-certified for installation in manufactured homes. For shielding purposes, the firestop thimble must pass through the manufactured home ceiling and extend up to the roof line of the manufactured home. See Figures 13 through 15. When an extension is needed, a thimble extension must be installed along with the firestop thimble. Models SVTR and SVTE thimble extensions have been safety-certified for use with this fireplace and should be installed as follows.

1. Lay out, cut and frame a square opening through the ceiling and roof structure at the point where the chimney will pass through. The SVTR firestop thimble requires a 14½"x14½" square opening. If the chimney is to go through a pitched roof, the hole in the roof must be rectangular instead of square. A 7½° pitch requires 14½"x14¾" framing. A 15° pitch requires a 14½"x15" framed opening.
2. Install the SVTR firestop thimble as shown in Figure 13. Nail it securely to the framing members. The firestop thimble should extend completely through the roof structure to shield combustible construction materials. If the SVTE thimble extension is needed, it should overlap the firestop thimble a minimum of 1". Screws should be used to secure the thimble extension to the firestop thimble. See Figure 14.

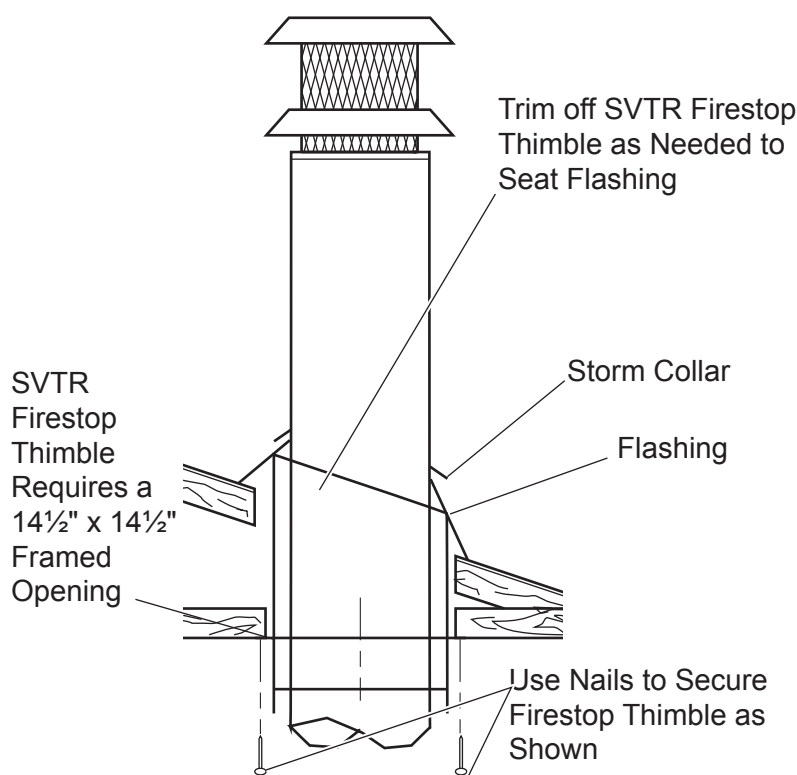

Figure 13 - Standard Roof

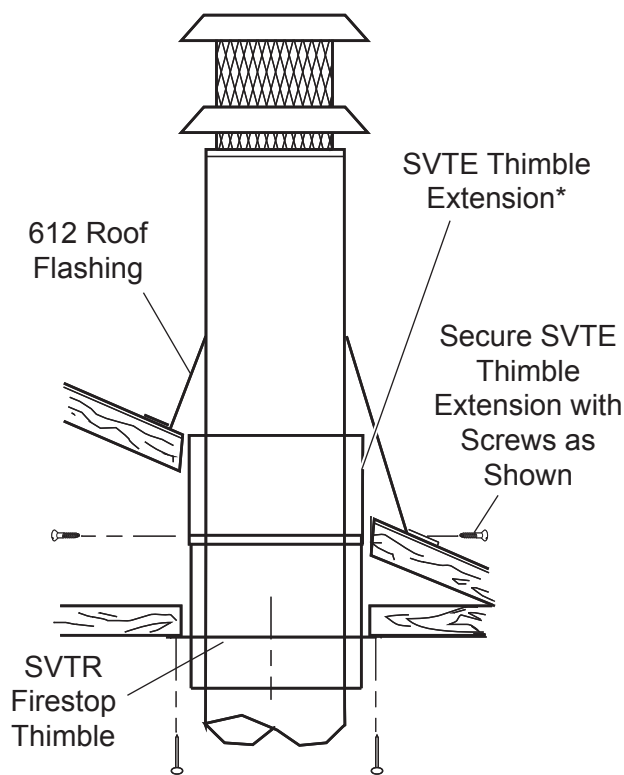

Figure 14 - Pitched Roof with Attic Space

* The SVTE Thimble Extension is required ...

1. In unvented attic space if attic space exceeds 8"
2. In vented attic space if total chimney height from floor to flue outlet is less than 13½'

Continued

CHIMNEY INSTALLATION

FIRESTOP THIMBLE AND THIMBLE EXTENSION (CONTINUED)

3. For unventilated cathedral type ceiling on double-wide manufactured homes, the firestop thimble should extend through both the ceiling and roof structures. See Figure 15.

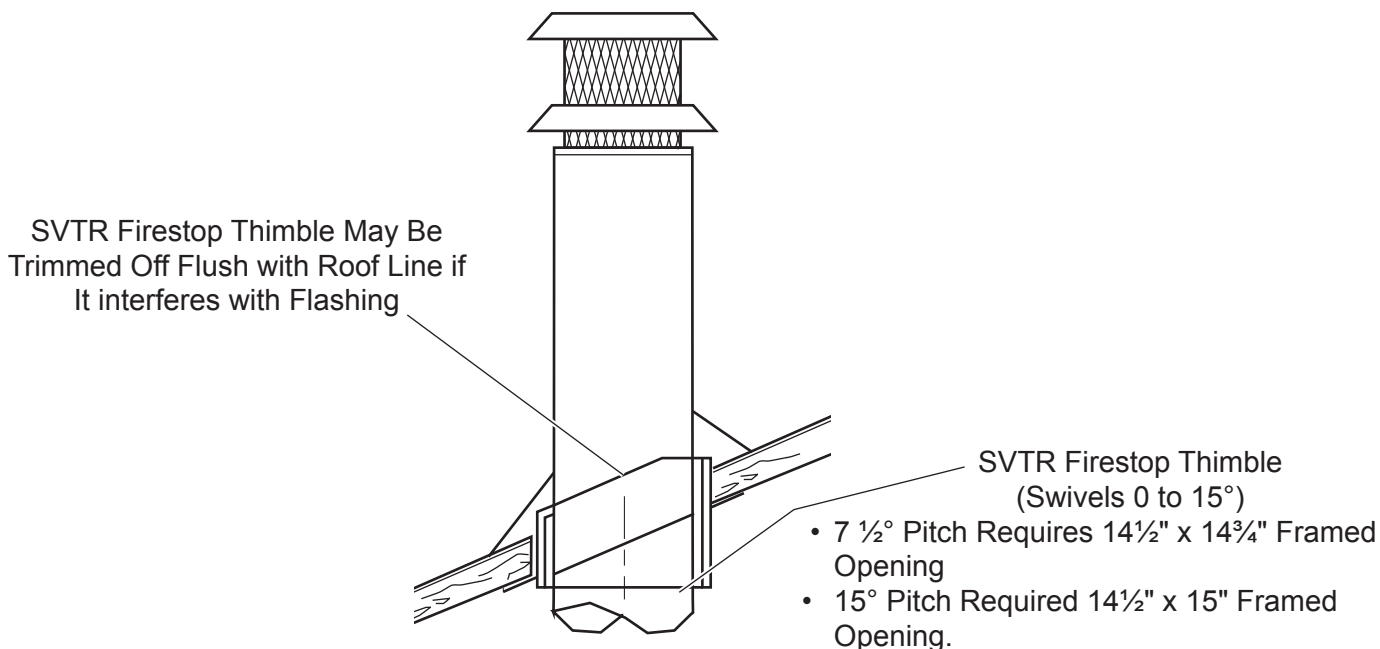

Figure 15 - Unvented Cathedral Type Ceiling

4. Install first chimney section by inserting the male end of the flue (the smallest diameter pipe) into the flue collar of the fireplace. Press down until the snap locks engage. Place the female end of the 11" diameter pipe on top of the fireplace and press down until the snap locks engage. Continue this process, until the chimney is at least 8" to 16" above the roof opening for installation of the Model SC Chimney Cap later. At this point, the chimney must not exceed 13 1/2' road clearance. This will allow the top section of chimney and chimney cap or chimney housing to be removed for moving the manufactured home on the highway.

Note: *If additional strength of the outer pipe joints is desired, place (2) or three (3) sheet metal screws through the area where the outer pipes overlap one another. Install these screws by drilling a 1/8" diameter hole through the chimney sections.*

WARNING

Be very careful when drilling holes into outer pipe. The drill must not penetrate the inner stainless steel pipe.

5. Make sure all joints of the chimney are tight. Check clearance between the chimney and combustible materials before proceeding with installation of the roof flashing and chimney cap.

ELBOW INSTALLATION

The following are important points that should be observed when installing elbows on the fireplace.

1. Securely nail down all four (4) support straps to the surrounding structure of all elbows not installed directly on top of the fireplace.

IMPORTANT: Use a minimum of two (2) 8-penny nails per strap. This allows the support strap to carry the weight of the chimney above the elbow and prevents this weight from breaking the elbow or chimney sections apart.

2. Do not use elbows in any combination that inclines the chimney more than 30° from vertical. See Figure 16.
3. The minimum height of the fireplace and chimney system when using 1 pair of elbows is 13'

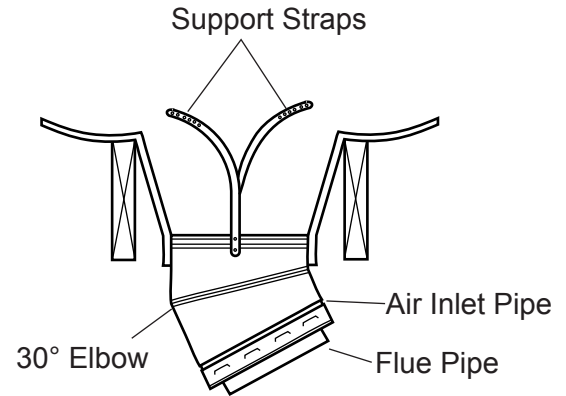

Figure 16 - Elbow Supports

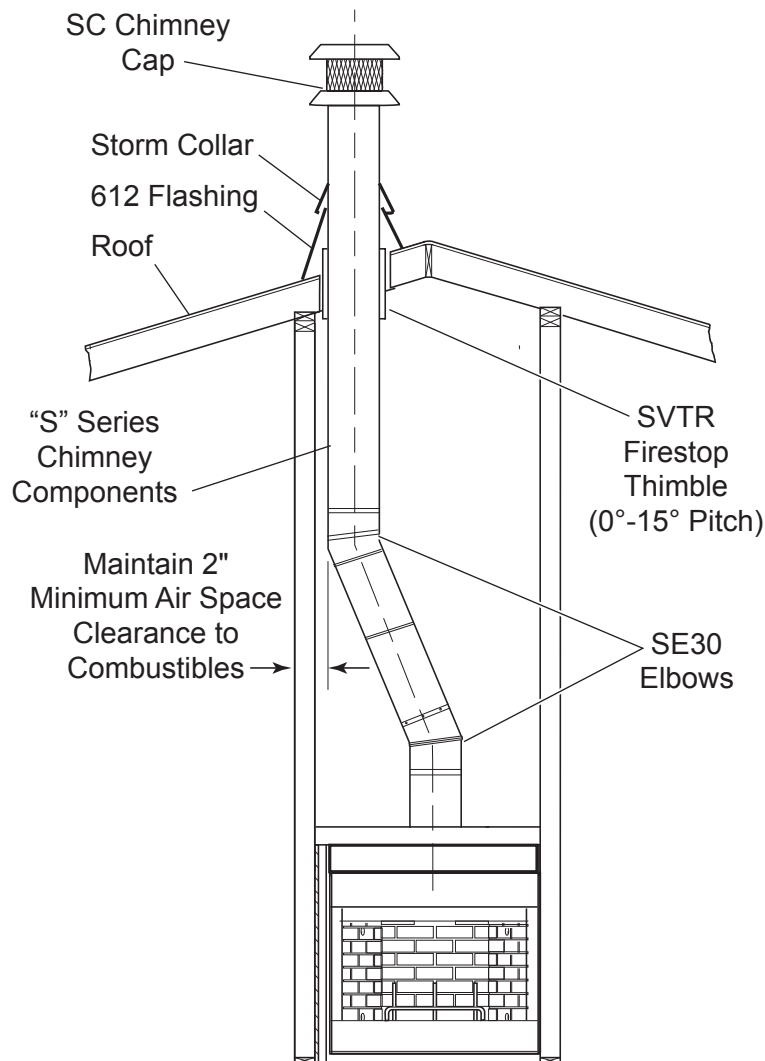

Figure 17 - Typical Chimney Offset Installation

4. Inclined portions of chimney are often used as storage. Enclose the inclined portions of chimney that pass through living spaces to avoid contact with and possible damage to chimney. Maintain minimum air space of 2" between chimney and enclosing. See Figure 17.
5. The length of inclined portion of chimney between elbows must not exceed 6' if it is not supported.

The length of inclined portion of chimney between elbows must not exceed 20' if it is supported every 6' with metal support straps.

6. When enclosing the elbows and inclined portions of the chimney, enclosing materials must be installed vertically to maintain the required 2" minimum air space clearance to the chimney at the extremities of the offset. It is best that enclosing material not follow inclined portions of chimney.

CHIMNEY INSTALLATION

OFFSET INSTALLATION SEQUENCE

Determine the location and amount of offset required. Select the combinations of chimney sections and elbows required from the *Chimney Height and Offset Charts*.

Continued

CHIMNEY HEIGHT CHART (FROM TOP OF UNIT OR FINISHED HEARTH)

Height (Inches)	Intermediate Sections			
	12"	18"	36"	48"
35	0	0	1	0
39	2	1	0	0
47	0	0	0	1
52	0	1	0	0
58	1	0	0	1
64	0	1	1	1
70	0	0	2	0
75	1	1	0	1
82	0	0	1	1
87	0	1	2	0
94	0	0	0	2
99	0	1	1	1
105	0	0	3	0
111	0	1	0	2
117	0	0	2	1
122	0	1	3	0
129	0	0	1	2
134	0	1	2	1
141	0	0	0	3
146	0	1	1	2
152	0	0	3	1
158	0	1	0	3
164	0	0	2	2
169	0	1	3	1
176	0	0	1	3
181	0	1	2	2
188	0	0	0	4
193	0	1	1	3
199	0	0	3	2
205	0	1	0	4
211	0	0	2	3
216	0	1	3	2
223	0	0	1	4
228	0	1	2	3
235	0	0	0	5
240	0	1	1	4
246	0	0	3	3
252	0	1	0	5
258	0	0	2	4
263	0	1	3	3
270	0	0	1	5
275	0	1	2	4
282	0	0	0	6
287	0	1	1	5
293	0	0	3	4
293	1	0	0	6
305	0	0	2	5
310	0	1	3	4
317	0	0	1	6
322	0	1	2	5
329	0	0	0	7

Height (Inches)	Intermediate Sections			
	12"	18"	36"	48"
334	0	1	1	6
340	0	0	3	5
346	0	1	0	7

Height (Inches)	Intermediate Sections			
	12"	18"	36"	48"
352	0	0	2	6
357	0	1	3	5
364	0	0	1	7
369	0	1	2	6
376	0	0	0	8

CHIMNEY SECTIONS WITH ELBOW OFFSETS

Elbow Set	Chimney Sections				Total Inches OffSet	Total Inches Rise
	12"	18"	36"	48"		
1	0	0	0	0	4 ¹ / ₂	17
1	1	0	0	0	10	26 ¹ / ₂
1	0	1	0	0	13	31 ³ / ₄
1	2	0	0	0	15 ¹ / ₂	36
1	1	1	0	0	15 ¹ / ₂	41 ¹ / ₄
1	0	0	1	0	22	47 ¹ / ₄
1	2	1	0	0	24	50 ³ / ₄
1	0	0	0	1	28	57 ³ / ₄
1	20	1	1	0	30 ¹ / ₂	62
1	1	0	0	1	33 ¹ / ₂	67 ³ / ₄
1	0	1	0	1	36 ¹ / ₂	72 ¹ / ₂
1	0	0	2	0	39 ¹ / ₂	77 ¹ / ₂
1	1	1	0	1	42	82
1	0	0	1	1	45 ¹ / ₂	88
1	0	1	2	0	48	92 ¹ / ₄
1	0	0	0	2	51 ¹ / ₂	98 ¹ / ₂
1	0	1	1	1	54	102 ³ / ₄
1	0	0	3	0	57	107 ³ / ₄
1	0	1	0	2	60	113 ¹ / ₄
1	0	0	2	1	63	118 ¹ / ₄
1	0	1	3	0	65 ¹ / ₂	122 ¹ / ₂
1	0	0	1	2	69	128 ³ / ₄
1	0	1	2	1	71 ¹ / ₂	133
1	0	0	0	3	75	139 ¹ / ₄
1	0	1	1	2	77 ¹ / ₂	143 ¹ / ₂
1	0	0	3	1	80 ¹ / ₂	143 ¹ / ₂
1	0	1	0	3	83 ¹ / ₂	154
1	0	0	2	2	86 ¹ / ₂	159
1	0	1	3	1	89	163 ¹ / ₄
1	0	0	1	3	92 ¹ / ₂	169 ¹ / ₂
1	0	1	2	2	95	173 ³ / ₄
1	0	0	0	4	98 ¹ / ₂	180
1	0	1	1	3	101	184 ¹ / ₄
1	0	0	3	2	104	189 ¹ / ₄
1	0	1	0	4	107	194 ³ / ₄
1	0	0	2	3	110	199 ³ / ₄
1	0	1	3	2	112 ¹ / ₂	204
1	0	0	1	4	116	210 ¹ / ₄
1	0	1	2	3	118 ¹ / ₂	214 ¹ / ₂
1	0	0	0	5	122	220 ³ / ₄

STRAIGHT RUN CHIMNEYS

Chimney support is required at 25' chimney height.

CHIMNEYS WITH ELBOW OFFSETS

The length of the inclined portion of the chimney between elbows must not exceed 6' when unsupported.

The length of the inclined portion of the chimney between elbows must not exceed 20' if the chimney is supported at 6' intervals using either metal support straps or an SCS chimney support.

The SCS chimney support when installed at a 30° angle will add 8' of rise and 4⁵/₈" of offset to the chimney height calculations.

OFFSET INSTALLATION SEQUENCE (CONTINUED)

1. Install the first SE30 elbow by placing the male end of the 8" diameter flue elbow into the mating part of the fireplace or chimney section. Press down until the snap locks engage.
2. Insert the female end of the 11" diameter outer elbow onto the mating part of the fireplace or chimney section. Press down until the snap locks engage.
3. Nail the support straps to the framing member with a minimum of two (2) 8-penny nails per strap.
4. Install the sections of pipe between elbows until the proper number of chimney sections have been installed.
5. Install the second elbow to return the run of the chimney to vertical.
6. Nail the support straps of the second elbow to a building frame member.
7. Continue installing the vertical portion of the chimney.

CHIMNEY CAP INSTALLATION

MODEL SC CHIMNEY CAP

Note: The proper chimney height is important to assure proper draft and safety. The SC chimney cap must extend the flue outlet 4" above the top of the last section of chimney. Keep this mind when determining the proper height for the chimney. The chimney should not be extended more than 90" above the supporting roof structure without additional support.

CAUTION

For safety and proper draft, the chimney must be at least 3' higher than the highest point where it passes through the roof. It also must be at least 2' higher than the highest part of the roof or structure that is within 10' of the chimney. See Figure 18.

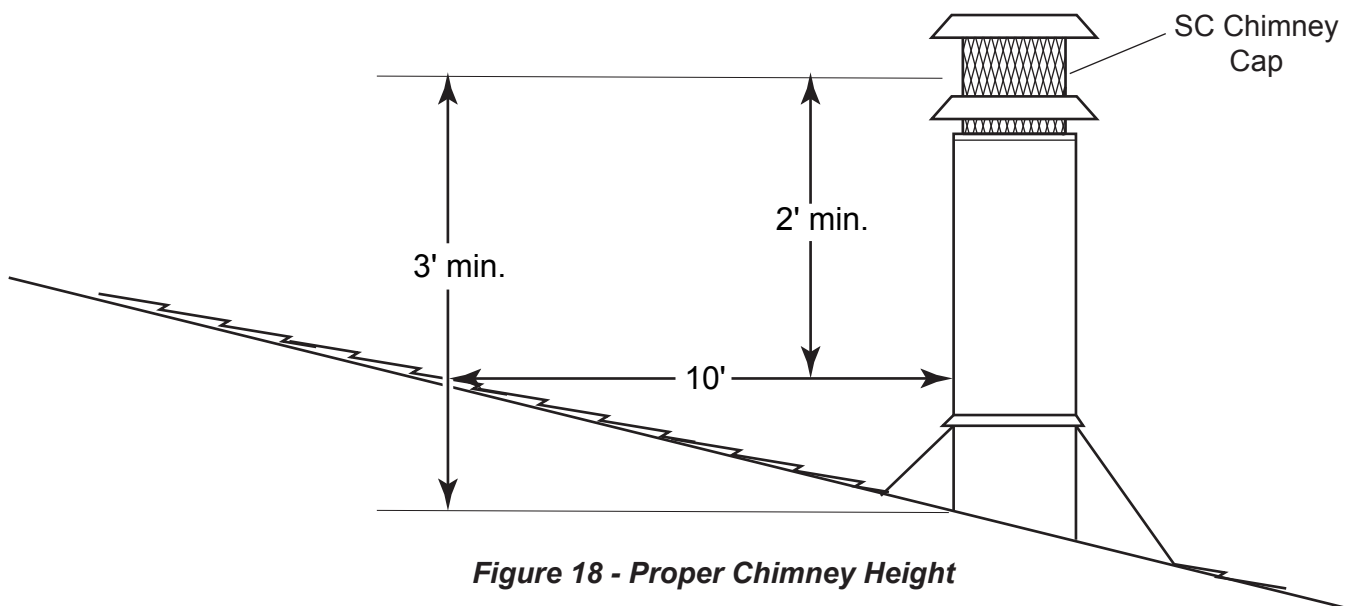

Figure 18 - Proper Chimney Height

CHIMNEY INSTALLATION

CHIMNEY CAP INSTALLATION (CONTINUED)

CAUTION

Be careful to avoid electrical shock hazard when contacting wires to metal chimney components.

1. Extend the regular chimney sections until the top of the chimney is 4" below the total flue height desired.
2. Remove the shingles from around the chimney so that the flashing may be installed and sealed.

For metal roofs: Install flashing on top of roof covering. Nail flashing down with at least eight (8) nails.

For standard roofing shingles: Remove the shingles from around the chimney so that the flashing may be installed. Install the upper part of the flashing under the shingles.

3. Set the flashing on the roof. Scribe a line around the flashing. Cut $\frac{1}{4}$ " below the scribed line. This should increase the diameter of the flashing outlet enough to allow the flashing to be placed over the chimney. *See Figure 19.*
4. Seal crack between the top of the flashing and the chimney with mastic. Leave some excess mastic at this area to be used by Step 6 below.
5. Place the storm collar around the chimney and put collar together like a belt in belt loops. With the loops facing up, slide the end of collar under the two loops on the other end. Overlap the ends of the collar until it is tight against the chimney. Bend the free end of the collar back over the loops to hold the storm collar securely together. Trim off the excess ends of the storm collar.
6. Slide storm collar down snugly against the flashing until the excess mastic left in step six is forced up into crack between the storm collar and chimney. This will make the joint between the flashing and the chimney watertight. *See Figure 20.*

7. Place chimney cap into matching parts of the last chimney section. Push chimney cap down until the brackets on the bottom of the chimney cap sits on the chimney pipe. Punch or drill $\frac{1}{8}$ " diameter holes in the inlet air duct (chimney pipe) where specified on the brackets. Fasten chimney pipe down with the No. 8 screws provided. *See Figure 20.*
Note: Do not penetrate the inner stainless steel pipe while installing the screws.
8. Check all the parts of the fireplace, chimney and chimney termination cap. Make sure none have been damaged or bent during installation. Check to see that all parts have been properly installed.

Note: The metal used for chimney cap has a rust-protective coating but the cut edges of the parts are not protected. Detergent-wash and paint exposed parts of chimney cap with galvanized primer paint. This will prevent rusting and rust staining of nearby structures.

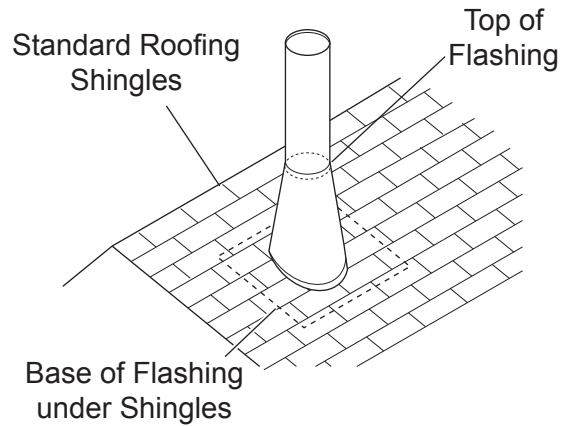

Figure 19 - Cutting Off Top of the Flashing

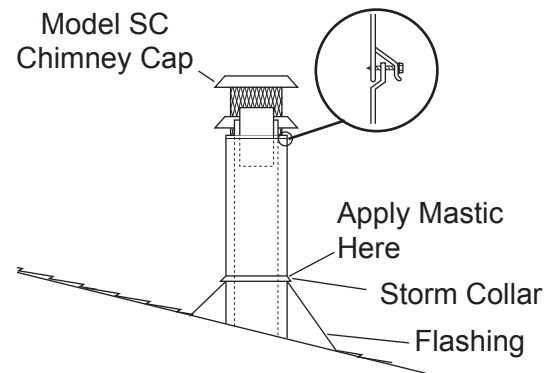

Figure 20 - Installing Storm Collar and Chimney Cap

CAUTION

Use pliers and wear gloves when handling the storm collar. The edge of the storm collar is sharp. If you are not careful, you could cut your hands.

WARNING

Fireplaces in manufactured homes must be supplied with outside combustion air.

These fireplaces are provided with model AK6A combustion air kit (for floor installation only) to supply outside combustion air to the fireplace.

If outside wall installation or ceiling/soffit installation is preferred, purchase model AK6 combustion air kit from fireplace dealer. *See Figure 10, page 12.*

PRECAUTION AND RECOMMENDATIONS

1. Avoid extremely long runs and numerous turns in the flex duct leading from the fireplace to the air inlet assembly. These conditions will increase the resistance to the free flow of air through the flex duct.
2. Locate air inlet assembly where it will not be blocked or restricted in any manner.
3. Never mount the combustion air inlet assembly in a garage or storage area where combustible fumes such as gasoline might be drawn into the fireplace. Do not take combustion air from any area where combustible liquids or gases are stored.
4. Carefully cut holes for the installation of the combustion air kit. You must maintain the structural integrity of the home.

CAUTION

Maintain the structural integrity of the manufactured home floor, wall, and ceiling/roof.

INSTALLATION OF AK6A COMBUSTION AIR KIT

1. Remove the cover plate from the combustion air inlet on left side of the fireplace.
2. Place the starting collar into the hole on the side of the fireplace. Fasten collar in place with four (4) sheet metal screws as specified by *Figure 21*.
3. Cut a 6½" diameter hole in floor leading into a ventilated crawl space and install the air inlet assembly. *See Figure 22.*

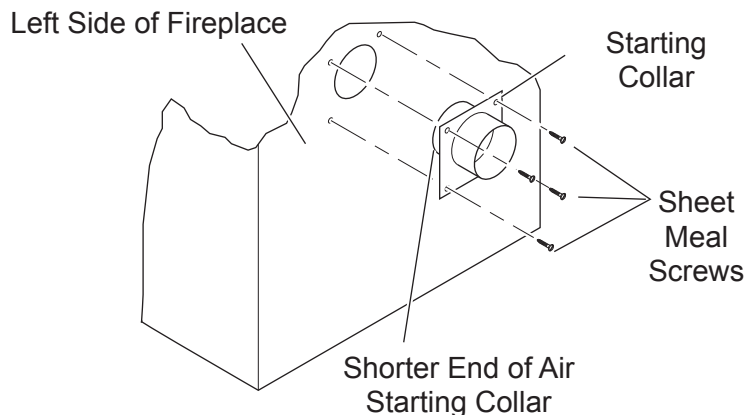

Figure 21 - Attaching Outside Air Starting Collar and Insulation Ring to Left Side of Fireplace

WARNING

Locate the air inlet assembly where it will not be blocked or restricted in any manner. The air inlet assembly must not terminate in an attic space.

4. Use duct straps to secure flex duct to starting collar and inlet air assembly. *See Figure 22.*

Note: If it is necessary to splice the flex duct, use Model 603 duct connector and Model FP-6-U combustion air duct.

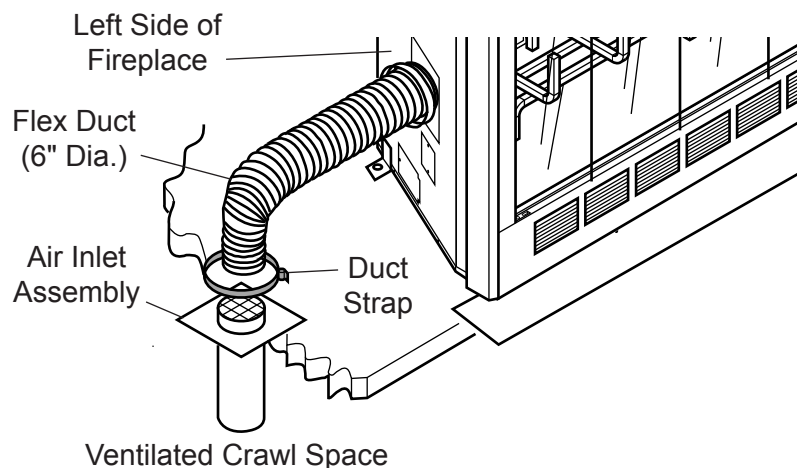

Figure 22 - Securing Flex Duct to Starting Collar and Inlet Air Assembly with Duct Straps

TRIM AND MANTEL INSTALLATION FOR WOOD BURNING FIREPLACES

- The fireplace face may be left exposed or trimmed with material such as brick, stone, or marble. If trim is installed, fasten it securely to face of fireplace. Seal any cracks between trim material and face of fireplace. Cracks can cause a fire and prevent fireplace from working properly. Block the fireplace with framing and attach the base to the supporting floor to reduce the possibility of such a crack developing.
- Place wall ties in mortar joints of masonry trim. Fasten wall ties to face of fireplace with sheet metal screws.
- Do not install combustible materials below the top spacers of the fireplace. Do not allow combustible materials to overlap the sides of fireplace face. Seal face of fireplace to surrounding wall with noncombustible caulk or trim materials. This will prevent cold air leaking around the fireplace. See Figure 23.
- Use only non-combustible materials below top of spacers.
- The trim must not block or restrict in any way the flow of air through the air inlet and air outlet louvers in the face of the fireplace.

WARNING

Seal any space between face of fireplace and non-combustible facing material. Failure to seal this crack is a possible fire hazard and will void the warranty.

WARNING

Do not block or restrict air inlets or air outlets. Blocking or restricting air inlets or air outlets could cause a fire hazard.

LOCATING FRONT AND SIDE CLEARANCES

To find front clearances, extend a line from back corner of unit to 4" in front of fireplace face and 1" outside screened opening. Combustible materials may be placed within shaded areas. **Note: Do not let combustible materials overlap black painted surface more than 1/8".** See Figure 24.

Trim may butt against side walls of fireplace. The other 3 walls must have 3/4" clearances.

To avoid interference with glass doors, do not allow non-combustible decorative trim to extend closer than 3/8" to the vertical edges of the firebox opening.

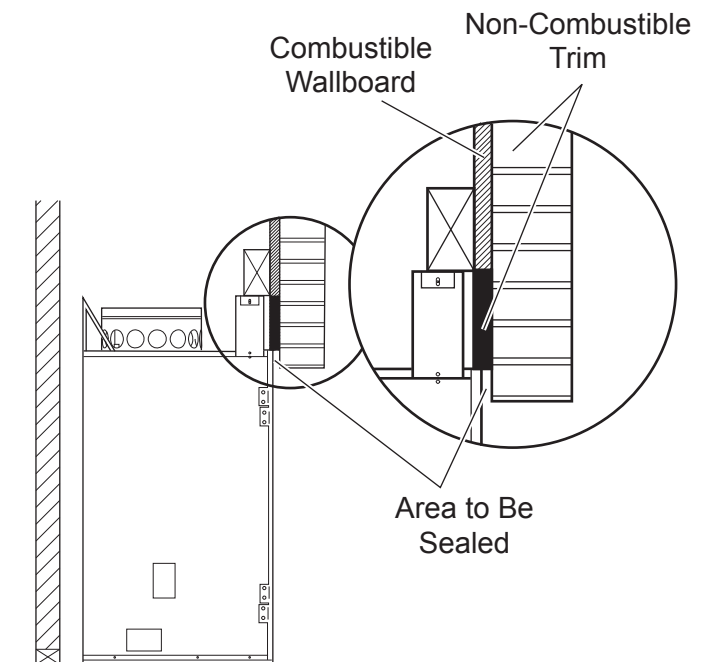

Figure 23 - Spacer Location

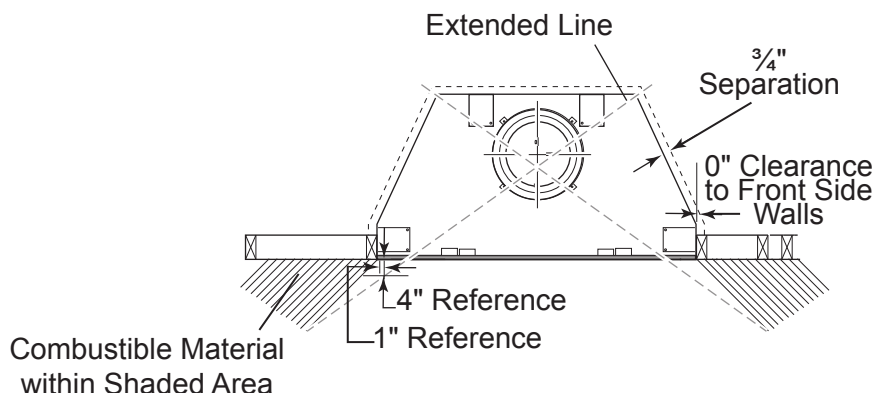

Figure 24 - Front and Side Clearances

TRIM AND MANTEL INSTALLATION FOR WOOD BURNING FIREPLACES

LOCATING MANTEL

Maximum depth of mantel is 12"

A = 6½" - Minimum from top of fireplace opening to bottom of any combustible trim material sticking out no more than 1½" beyond face of fireplace

B = 12" - Minimum from top of fireplace opening to bottom of combustible trim material sticking out more than 1½" from top of fireplace opening

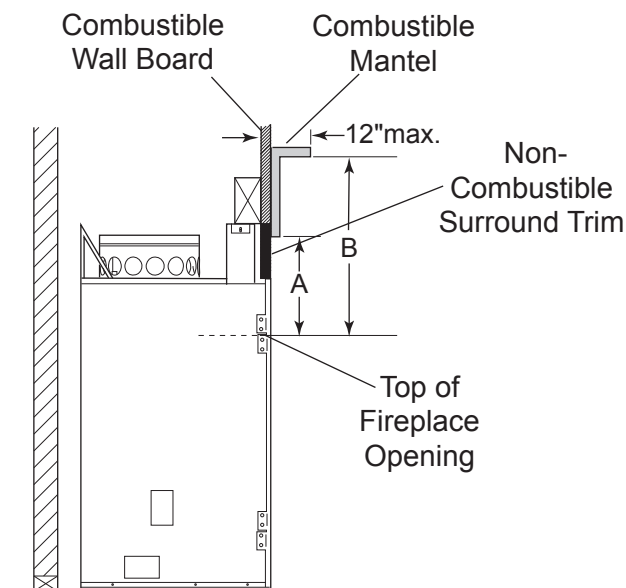

Figure 25 - Locating Mantel

FAN ASSEMBLY

This fireplace is equipped with a fan assembly to help circulate heat produced by the fireplace. The energy used by the fan assembly will be less than a 30 watt light bulb.

The fan assembly has been factory-wired to the fireplace receptacle box located on the right side of the fireplace. Connect wiring from the fireplace receptacle box (field-wired) to a 60 Hz, 120 vac, 15 amp electrical circuit. Field-wiring must comply with local codes or, in the absence of local codes, with the latest edition of National Electrical Code ANSI/NFPA 70. See Figure 26.

WARNING

Always check and make sure power is off before attempting to install or service any electrical wiring or components.

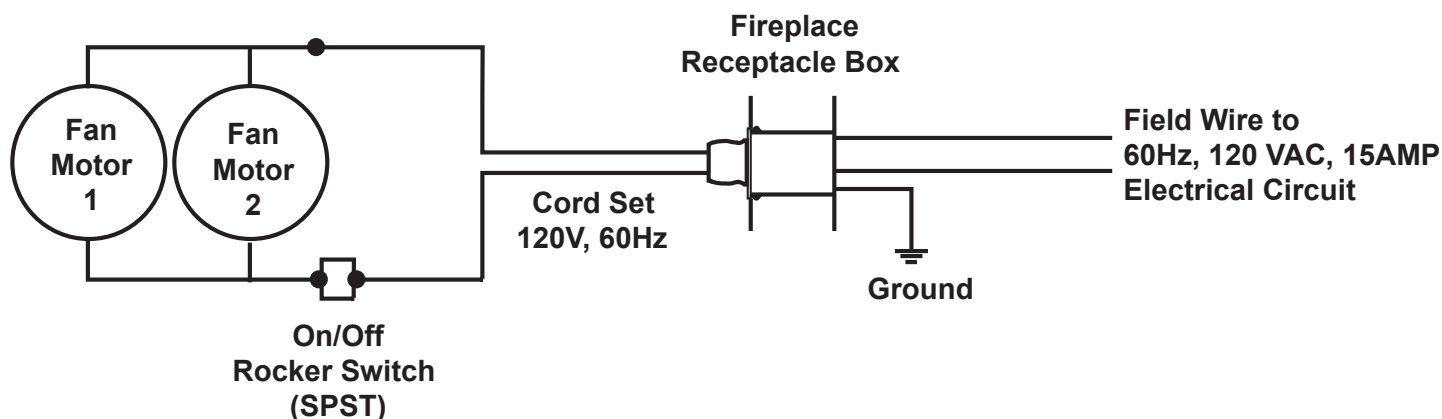

Figure 26 - Wiring Diagram

GLASS DOOR INSTALLATION

REMOVING GLASS DOORS

You need to remove the glass doors to replace a damaged glass panel, to replace a refractory component inside the fireplace, or to more easily access glass panels for cleaning purposes.

WARNING

Always use gloves and eye protection when handling glass doors in case glass is accidentally broken while handling.

Note: An adjustable spring clip is installed on each side of the top track for the glass doors. The spring clips are used to hold the doors in place and keep the doors aligned. A door closure spring is installed in the center of the top track. This closure clip provides friction to the door guide pins, which help hold the doors together properly.

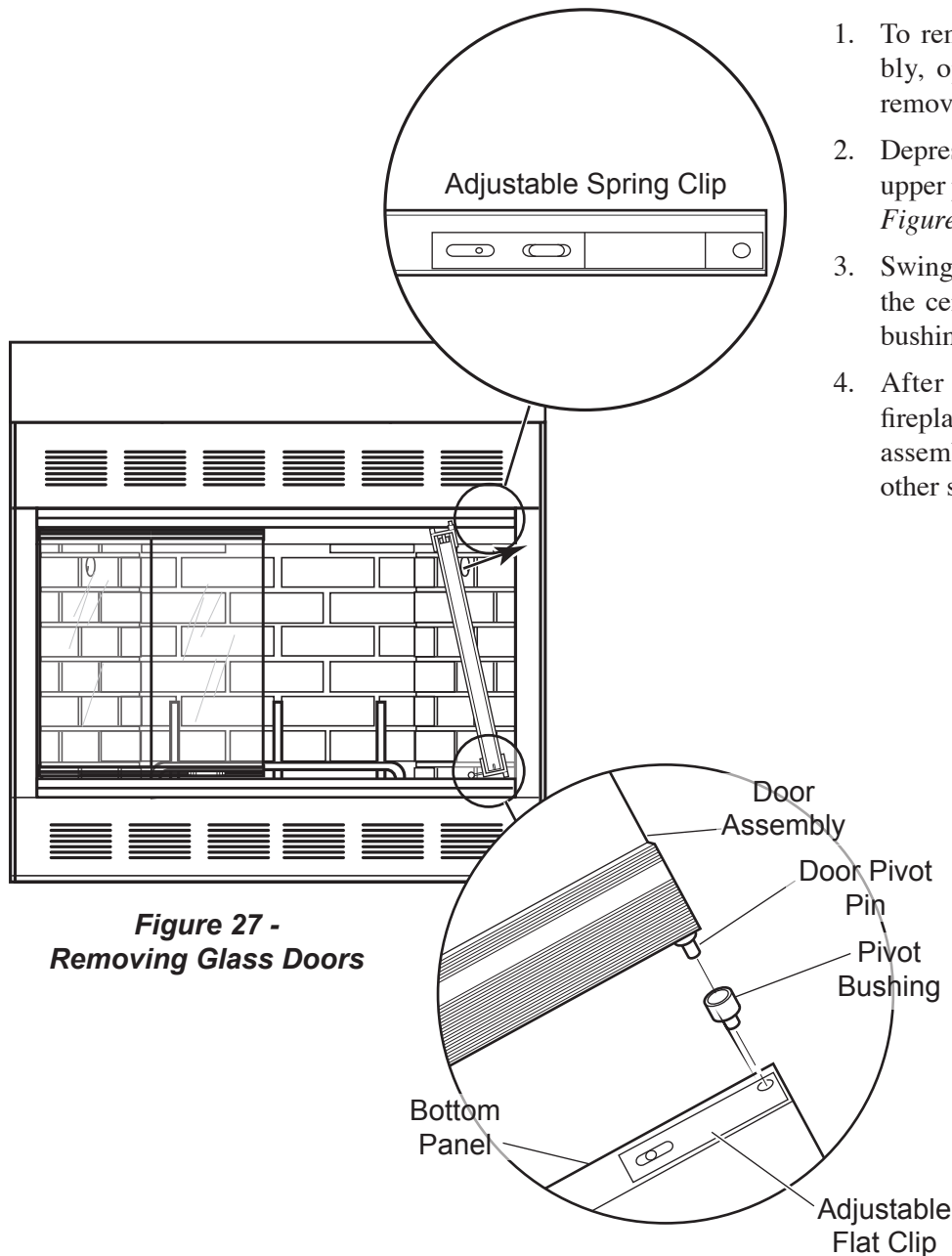

**Figure 27 -
Removing Glass Doors**

1. To remove a left or right glass door assembly, open the bi-fold door assembly to be removed.
2. Depress the top adjustable spring clip until the upper pivot pin disengages the spring clip. See Figure 27.
3. Swing the top of the door assembly towards the center and lift it out of the bottom pivot bushing. See Figure 27.
4. After removing a door assembly from the fireplace, be careful not to damage the door assembly by hitting or scratching it against other surfaces or objects.

REPLACING A GLASS PANEL

1. After removing door assembly, place the door assembly face down on a solid flat surface protected by cloth, cardboard, etc.
2. Carefully remove any broken or damaged glass panel. Locate glass spring retainers which keep the glass panels in the upper and lower trim channels. See *Figure 28*. Each panel of glass is kept in place with four (4) glass spring retainers. If any of the retainers are lost, order them when you order replacement glass panels.
3. To install a glass panel in the trim channels, slide the new glass panel in from the side.
4. Position the glass spring retainers approximately $1\frac{1}{4}$ " in from each corner of the glass panel. See *Figure 28*.
5. Gently compress (seat) the glass spring retainers between the trim channels and glass. Use channellock pliers to easily seat the glass spring retainers. Be careful when seating the spring retainers. Make sure you do not bend the outside edges of trim channels.
6. If you find the doors are not square after you have replaced the glass panels, fold the door together with the pivot and guide pins are on the bottom next to the cloth or cardboard. The hinges are on top. With the door in this position, gently press the trim to line it up with the glass panels. See *Figure 29*.

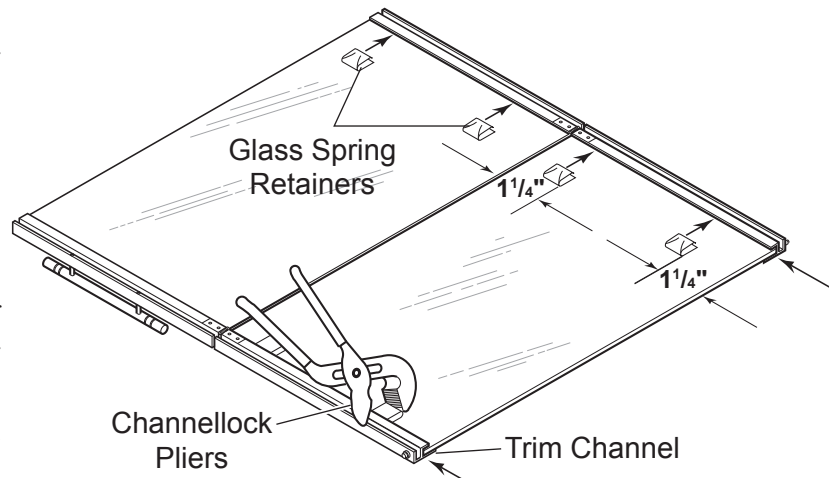

Figure 28 - Removing Glass Spring Retainers

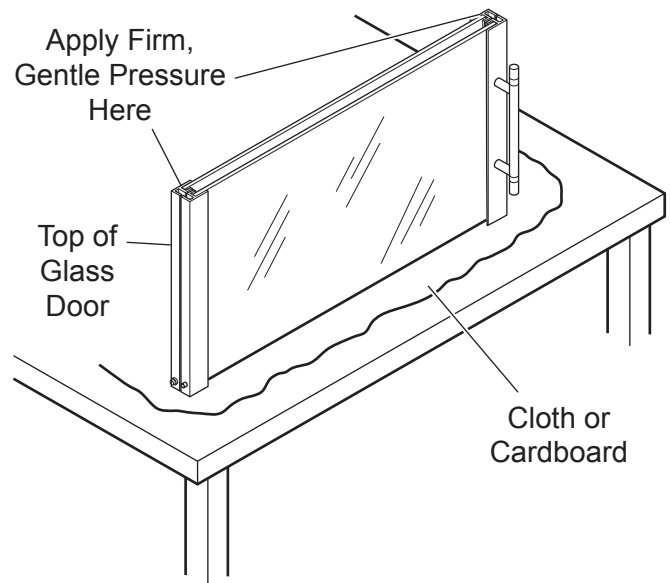

Figure 29 - Lining Up Glass Panels to Trim

Continued

GLASS DOOR INSTALLATION

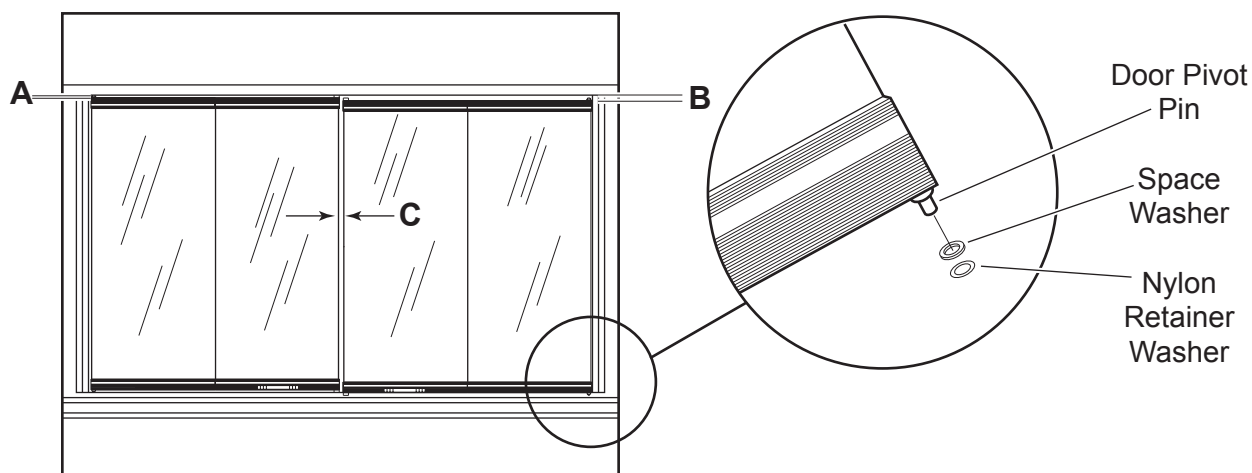

Figure 30 - Inserting Bottom Pivot Pin into Pivot Bushing

REINSTALLING GLASS DOOR

1. Insert the door's bottom pivot pin into the appropriate pivot bushing located in the bottom panel of the fireplace. *See Figure 30.*
2. With the door assembly folded together, gently maneuver the door assembly's upper pivot pin into the hole in the adjustable spring clip located in the top track for the glass doors.
3. Once the bi-fold doors are installed, check to see if dimensions A and B are equal. *See Figure 30.* If dimensions A and B are within $\frac{1}{16}$ " of being equal, you may only need to adjust the spring clips to make dimensions A and B equal. If dimensions A and B are more than $\frac{1}{16}$ " apart, place one or two spacer washers under a door's pivot pin. *See Figure 30* Use a nylon retainer washer to hold the spacer washers on the pivot pin as shown.

Note: *Normally, washers will only be needed when a misalignment condition exists as a result of a combination of tolerances ranging from glass size variations, fireplace opening variations, and/or units which are not framed in exactly square. If washers are ever needed, buy them from your fireplace dealer. Request spacer washer 037681 and retainer washer 046397 in the quantities needed.*

Only measure dimensions A and B when the door center spacing (dimension C) is an equal dimension from top to bottom between the two doors. To get equal dimensions, adjust **top** spring clips by loosening and tightening screws. The unit also has two (2) adjustable flat clips located where the door bottom pivot is inserted. *See Figure 27, page 24.* **Only adjust flat bottom clips if more adjustment is necessary.**

WARNING**Fireplace damper must be fully opened when using a gas appliance.**

ADVANTAGES OF A WOOD BURNING FIREPLACE

These are practical and ecological advantages of using wood as a fuel. Also to be considered is the aesthetic appeal. Most of us consider a wood fire with nostalgia. We enjoy the aroma and find the flickering light of a cozy hearth reminding us of things past. Wood has a low ash content. The little ash that remains after burning is useful in home gardening as a fertilizer and soil conditioner.

WHICH WOODS ARE BEST?

Each wood species offers something different in aroma or heat value. You should consider your needs and desires before building your fire.

Softwoods, like pine, spruce and fir are easy to ignite because they contain a lot of resin. However, a fire built entirely of softwoods burns out quickly. You also must add wood more often. While a softwood fire is not too desirable for a long evening, it's fine in the morning when you want quick warmth or late in the evening when you want a fire that will burn out before you go to bed.

On occasion when a longer fire is desired, it's best to combine softwoods with the heavier hardwoods such as ash, beech, birch, maple, oak and hickory. Hardwood burns slower, with shorter flames, and produce steady, glowing coals.

For the most pleasing aroma, burn the wood of fruit trees such as apple and cherry, or nut trees such as beech, hickory and pecan. This wood is generally more expensive, but a little combined with other wood goes a long way. Start your fire with a mixture of softwood and hardwood. Add some fruit or nut wood for nostalgic aroma. Since most woods will not burn well when freshly cut, the wood you purchase should be reasonably dry. Purchase logs that will fit when laid across your grate. Ask that the larger, heavier logs be split. Kindling should be short, easily split lengths of softwood, lumber yard or mill scraps, or twigs and branches gathered from your yard.

Do not burn plastics, poison ivy twigs and stems and chemically treated woods such as discarded poles and railroad ties in your fireplace. These create air pollution and can cause extreme irritation for some people.

Use hemlock, spruce, juniper and other resinous woods with caution. They contain moisture pockets which, upon heating, "pop" with considerable vigor.

Wood can be dried sufficiently for burning within a few weeks if protected from rain in a low humidity area. It is far better to cut wood and allow it to dry for a year. In all cases, the wood should be stacked so that both ends of the sticks are exposed to the air and protected from rain. The drier the wood, the more usable heat produced by the fire and less likely rapid accumulation of soot and creosote within the chimney is to occur. See the section of this manual concerning chimney maintenance for information concerning the hazards of soot or creosote accumulation. For safety, wood required for fire tending must be kept at least 30" from the fireplace.

Processed solid fuel firelogs may be used in these fireplaces. Do not poke or stir processed solid fuel firelogs while they are burning. Use only processed solid fuel firelogs that have been evaluated for the application in fireplaces and refer to firelog warning and caution markings on packaging prior to use.

WARNING**Do not use fireplace as an incinerator!****WARNING****Do not leave children or physically or mentally handicapped, or senile persons alone with a burning fireplace.**

DISPOSAL OF ASHES

Ashes, important because they form a bed of glowing coals, should only be left to accumulate within an inch or two of the bottom of the grate. Ashes may be used to check a flaming fire "bank" your fire by covering the logs with ashes. A "banked" fire will hold glowing coals for 8-10 hours, thereby saving a fire for later use.

Place ashes in a metal container with a tight fitting lid. Place closed container of ashes on a noncombustible floor or on the ground well away from all combustible materials until

FIREPLACE OPERATION

BUILDING AND TENDING A FIRE

The first three fires should be of moderate size to allow the fireplace to adjust and cure before being subjected to larger fires.

First, make sure your room is well ventilated, your damper open and the flue is unobstructed. Then make sure your wood is dry and seasoned. Unseasoned wood burns poorly. If you use unseasoned wood with poor ventilation or an obstructed chimney, smoking could occur.

Open the outside combustion air damper by pushing upward on its control lever located above the firebrick on the left side of the firebox. This damper should be open while the fireplace is in use. *See Figure 5, page 7.*

The flue damper control lever is located just below the upper grille of the fireplace. You can reach the control lever through the front opening of the fireplace. The damper is operated by simply unlocking up to open or pulling and locking down to close.

WARNING The flue damper is counterweighted to maintain the fully open position. The flue damper must be fully open while the fireplace is in use. The flue damper must be open unless the fire is completely out and all smoking has stopped.

WARNING Never use gasoline, gasoline-type lantern fuel, kerosene, charcoal lighter fluid, or similar liquids to start or “freshen up” a fire in this fireplace. Keep all such liquids well away from the fireplace while it is in use. Use of this fuel can cause a serious explosion.

WOOD VS. FOSSIL FUELS

Compared to fossil fuels, a full cord of dry hickory weighs about two tons and is approximately equal in heating value to a ton of hard coal. On a per pound basis, heavy hardwoods have about half the heating value of coal. The table below shows the relative densities and heat values of a variety of dry woods. Varieties at the top of the list (Dogwood) burn longer and those near the bottom (White Pine) ignite and burn quicker. A combination of both light and heavy wood is desired.

SPECIES VALUE	DENSITY	HEAT
Dogwood	.70-.79	100-107
Hickory	.70-.74	100
Oak	.60-.73	86-99
Black Locust	.69-.70	95-98
Beech	.64-.66	89-91
Hard Maple	.58-.65	83-88
Birch	.55-.64	79-86
Apple	.58-.62	83-84
Ash	.57-.61	81-82
Southern Pine	.51-.60	73-81
Elm	.50-.59	71-80
Cherry	.50-.52	70
Douglas Fir	.45-.51	64-69
Spruce	.41-.44	59
Redwood	.33-.40	47-54
White Pine	.35-.37	50

GLASS DOORS

The glass doors on the fireplace must be fully open while building a fire. The glass doors may be closed after the fire is established, but do not close the doors on an excessively hot fire as this may harm the glass in the doors. The glass must be allowed to warm slowly. The tempered glass in the doors will withstand a gradual temperature rise to 550°F, which is more than a normal fire will create. Keep the fire well back from the doors and never let flames contact the glass.

If a fire gets too large at any time:

- Open both glass doors to quickly reduce the heat in the firebox
- Push wood to the rear of the firebox and rearrange it into a single layer
- Let the fire burn to a smaller size before closing the glass doors again.

When the glass doors are open, close the mesh firescreen to reduce the possibility of sparks or embers popping onto combustible flooring or furnishings. The fireplace is most efficient with the glass doors open for moderate and large fires, and closed for small fires. The fan may be operated to help circulate heat produced by the fireplace. Use the ON/OFF rocker switch, installed in the lower grille on the front of the fireplace, to turn the fan on and off.

Prepare your fire by placing two logs on the iron grate or fire basket, and laying the tinder between them. Tinder may be dry scrap paper, twigs or bark. On top place a small handful of twigs or split softwood kindling. Place more dry logs over this base. Keep logs close together, as narrow air spaces between them promote better drafts. Heat reflected between adjacent surfaces aids in raising and maintaining combustion temperatures.

You'll need a minimum of three logs, preferably four, to make a good fire. Add kindling and new logs as needed to rekindle a dying fire. New logs should be added at the rear grate after raking the coals toward the front. **Note: Do Not Overfire the Fireplace.** Overfire conditions happen when you use large amounts of kindling, building scraps or other improper fuels.

WARNING

Glass doors should be **FULLY OPEN** or **FULLY CLOSED** when operating fireplace. Partially opened doors may allow gas and flame to be drawn out of the fireplace opening. This creates a risk of both fire and smoke. See *Figures 3 and 4 on page 7.*

WARNING

When leaving the fireplace unattended, close either the glass doors or the firescreen.

MAINTENANCE

FIREPLACE MAINTENANCE

At the end of each heating season or when the fireplace will not be in use for an extended time, the ashes should be removed and the hearth area should be swept clean. The slow absorption of moisture into the ashes over a long period of time could corrode metal fireplace parts.

At the beginning of each heating season, always operate the flue damper and make sure it has not become stuck from soot, creosote, dirt, lint, etc., during the period of inactivity.

Use a duster or vacuum to keep the lower and upper grille panels of the fireplace clean and free from dirt and lint accumulation. Wipe the painted surfaces of the fireplace with a soft cloth to remove dust and lint. A black touch-up paint, available from your dealer, may be used to touch up the painted surfaces of the fireplace.

The fan motor is permanently lubricated and does not require oiling. Periodically remove lint and dust from the motor and fan blades. Excessive accumulations of lint and dust on the motor and fan blades can shorten the life of the motor by causing the motor to overheat. To gain access to the fan assembly, remove the bottom refractory of the fireplace. *See Figure 31.*

WARNING

Disconnect the electric supply to the fireplace before servicing or repairing the fan to avoid an electrical shock hazard.

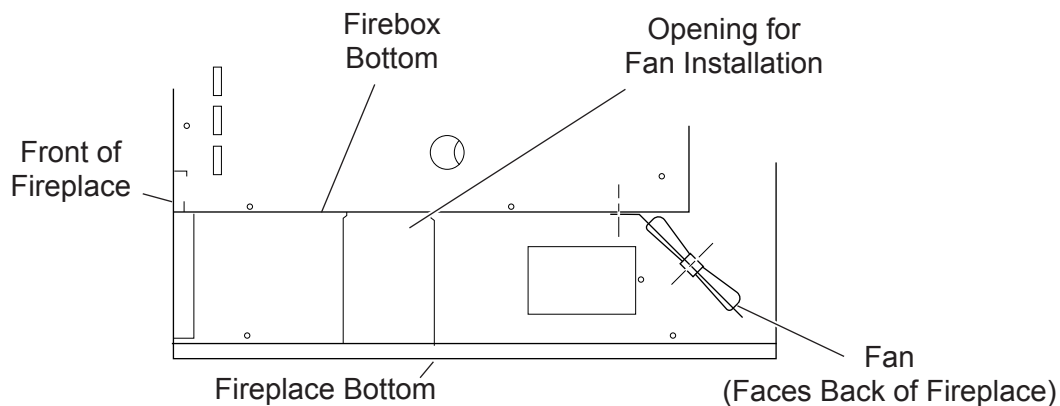

Figure 31 - Blower Location (Side View)

GLASS DOOR MAINTENANCE

The glass doors on the fireplace are built to require very little maintenance. The surfaces of the brass frames are coated with a clear baked-on enamel to prevent tarnishing of the brass. The brass finish is treated to withstand temperatures up to 600°F, which is higher than normal fireplace operation.

IMPORTANT: Do not polish the brass finish. Use mild soapsuds and a soft cloth to clean brass surface.

The glass panels in the door assemblies are tempered and will withstand temperatures up to 550°F, which is higher than normal fireplace operation.

IMPORTANT: Make sure the glass panels are completely cool before cleaning. Do not attempt to clean a hot glass panel.

Clean the inside and outside surfaces of the glass with a household glass cleaner and a soft cloth, or a mild detergent-water solution and a soft cloth. Do not use abrasive cleansers. Abrasive cleansers could scratch the glass surface.

The glass is eight times stronger than conventional plate glass, but it is possible to break the glass through abuse or overheating. Take care not to chip or scratch the glass. Chipped or scratched glass can break suddenly when heated. If a glass panel breaks, order replacement glass panels from your fireplace dealer.

**REFRACTORY COMPONENTS
MAINTENANCE**

Over time, expansion and contraction will cause minor cracking of the hearth, back, and side refractory components. This is normal and unavoidable. If the cracks become large enough or parts dislodge and metal behind the refractory is exposed, the refractory components should be replaced with new components obtained from your fireplace dealer.

**REMOVING AND INSTALLING FIREPLACE
REFRACTORY COMPONENTS
(BRICK PANELS AND HEARTH)**

1. Remove glass doors. *See Pages 24 and 26.*
2. Remove retainer clip from grate retainer. *See Figure 32.*
3. Lift grate up and out of grate retainer.

Remove Hearth

4. Lift back edge of hearth upward using the two grate retainers. Pull hearth toward you. Remove hearth. *See Figure 33.*

Remove Side Brick Panels

5. Pull back edges of side brick panels toward center of fireplace while sliding front edges toward rear of fireplace. *See Figure 34. IMPORTANT: Do not allow back brick panel to fall forward.*

Remove Back Brick Panel

6. Pull back brick panel toward the front of fireplace. Lift back brick panel out. *See Figure 35.*

Installing Brick Panels

7. Reverse steps 1 through 7 to install new brick panels.

NOTE: Position grate retainer before installing new hearth. *See Steps 1 through 3.*

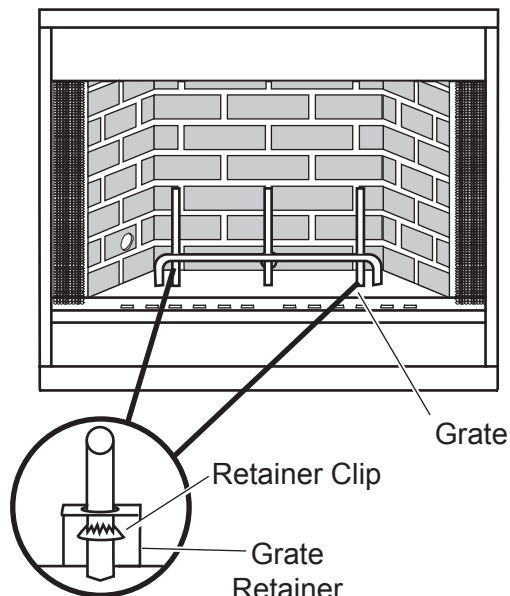

Figure 32 - Retainer Location.

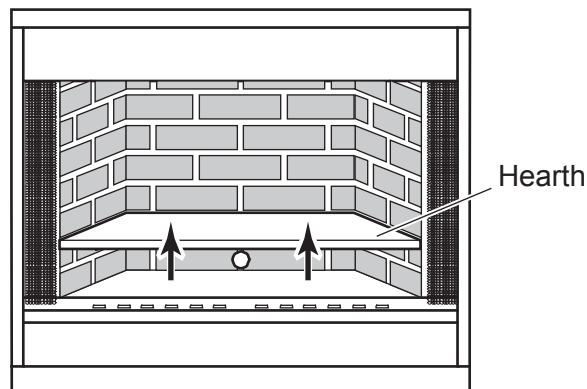

Figure 33 - Removing Hearth

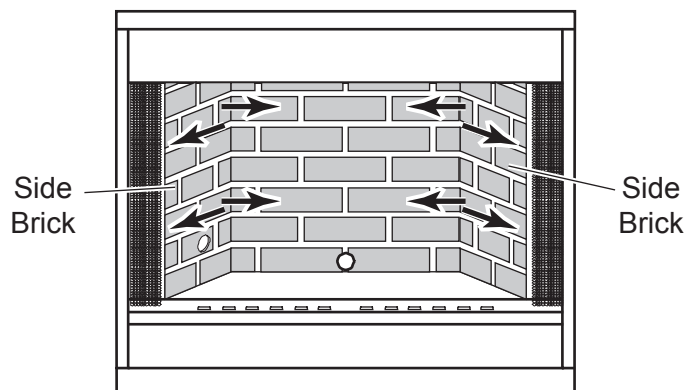

Figure 34 - Removing Side Brick

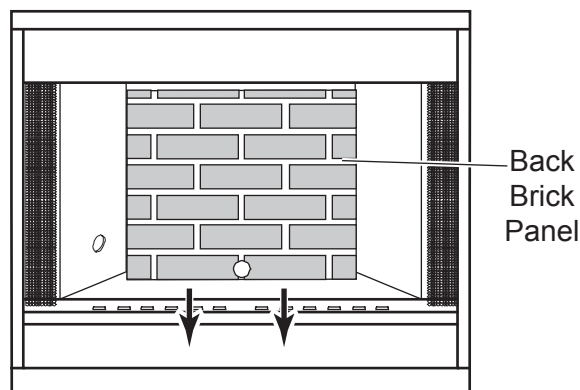

Figure 35 - Removing Hearth

MAINTENANCE

CHIMNEY MAINTENANCE

Creosote, Formation and Need for Removal

When wood is burned slowly, it produces tar and other organic vapors which combine with expelled moisture to form creosote. The creosote vapors condense in the relatively cool chimney flue of a slow-burning fire. As a result, creosote residue accumulates on the flue lining. When ignited, this creosote makes an extremely hot fire.

Note: The chimney should be inspected at least twice a year during the heating season to determine if a creosote buildup has occurred. If creosote has accumulated it should be removed to reduce the risk of a chimney fire.

The chimney cap can be removed for inspection, maintenance and cleaning by removing three screws from the support legs and lifting upward.

When the fireplace is new, inspect the chimney often and clean the chimney any time creosote is seen on the flue walls. Once you see a pattern of how often creosote is accumulating, you can determine how often the chimney should be inspected.

Also changes in the outside environmental conditions such as temperature and humidity or changes in the operation of the fireplace can lead to rapid buildup of soot and/or creosote.

Have a a qualified and reputable chimney sweep clean the chimney or remove creosote or soot with brushes on wooden or fiberglass poles. ***Note: Do not use metal pipes, chains, wires, etc., to clean the chimney. They can scratch the surface of the stainless steel flue. This will shorten the life of the flue and provide a rough surface for soot particles to attach to.***

Be sure to cover nearby furnishing and arrange some method of catching soot and creosote particles that may fall during the chimney cleaning process. If glass doors are installed on the fireplace, they should be closed. Extra caution must be used to avoid damage to the flue damper during the cleaning process.

In addition to checking and cleaning the chimney on a regular basis, be sure to inspect the chimney before starting a fire at the beginning of each heating season. Make sure the chimney is clear from any accumulation of soot, creosote or any other debris. Make sure all joints are intact.

Do not use chemical cleaners because some may contain elements that corrode the metal parts of the chimney or fireplace.

CHECKLIST OF DO'S AND DON'TS**DO's**

1. Do check with local building officials to be sure the installation of the fireplace complies with all building codes and requirements. Obtain required building permits. Do plan your installation with safety as your primary consideration.
2. Do use only the prescribed material and parts for the installation of the fireplace.
3. Do block in or fasten the fireplace to prevent the possibility of the fireplace shifting out of position.
4. Do keep all flammable liquids, gases and pressurized containers away from the fireplace.
5. Do use the grate furnished with and for this fireplace.
6. Do start a fire only with paper, kindling or solid composition fire starters specifically designed for starting a fire. The use of liquid fire starter can cause an explosion within the fireplace.
7. Do use glass doors and firescreen as specified by these instructions.
8. Do check the fireplace for proper adjustment and operation before leaving it unattended for long periods of time.
9. Do inspect and clean the fireplace chimney regularly.
10. Do place all ashes in a metal container with a tight fitting lid and place them on a noncombustible surface well away from other combustible materials until they have completely cooled.

DON'Ts

1. Don't install the fireplace on a poorly constructed base or fail to fasten down or attach the fireplace to prevent it from shifting out of position.
2. Don't install the fireplace where flammable or explosive liquids or vapors are likely to be present.
3. Don't neglect all the considerations mentioned in this manual concerning clearances to combustibles, spacing from obstructions and proper chimney height when selecting the location and installing the chimney.

Don't store or place flammable liquids, gases or pressurized containers near the fireplace.

Don't put combustibles within 24 inches of the fireplace opening.

Don't store fuel supply closer to the fireplace than the minimum spacing required for combustible materials.
4. Don't neglect to instruct all responsible persons in the proper and safe operation of the fireplace.
5. Don't fail to instruct all persons, especially children and elderly persons, concerning the hazards of improper operation and unauthorized tampering with the fireplace.
6. Don't use gasoline, kerosene, engine oil, charcoal lighter fluid or other flammable liquids to start or intensify a fire. Using these and similar materials can cause an explosion within the fireplace.
7. Don't subject the fireplace to the intense heat of a large fire the first three times the fireplace is used, but build moderate fires to allow the materials to cure and adjust.
8. Don't neglect to inspect and clean the chimney regularly.
9. Don't use the fireplace or chimney for venting wood or coal burning heaters or inserts unless approved in writing by Monessen Hearth Systems.
10. Don't attempt to use the fireplace until the installation is complete.
11. Don't clean the chimney with metallic devices or chemical cleaners.

WARNING

If not installed, operated and maintained in accordance with the manufacturers instructions, this product could expose you to substances in fuel or from fuel combustion which can cause death or serious illness and which are known to the state of California to cause cancer, birth defects or other reproductive harm. Also, operation, installation and servicing of this product could expose you to airborne particles of glass wool fibers known to the state of California to cause cancer through inhalation."

REPLACEMENT PARTS

REPLACEMENT PARTS ARE AVAILABLE THROUGH YOUR RETAILER

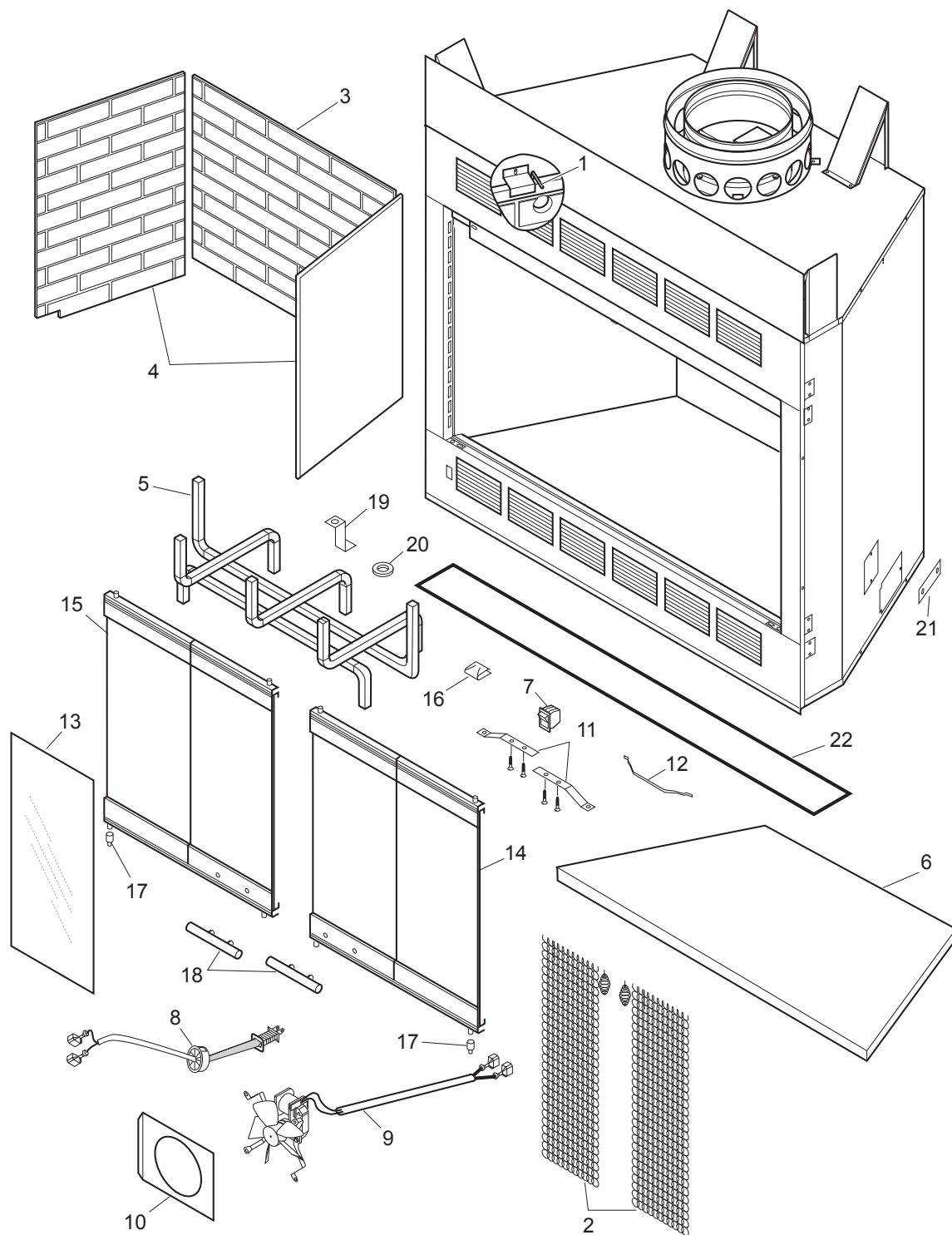

WARNING

Failure to position the parts in accordance with these diagrams or failure to use only parts specifically approved with this appliance may result in property damage or personal injury.

REPLACEMENT PARTS

Item	Description	Qty	BWBC400MHB	BWBC500MHB
1	Weldment Air Door Rod	1	031867	031867
2	Firescreen Panels	2	61D0001	61D0003
3	Back Firebrick Assembly	1	61D0102	61D0107
4	Side Firebrick Assembly	2	61D0101	61D0101
5	Painted Grate Assembly	1	61D0020	61D0022
6	Hearth Refractory Assembly	1	61D0100	61D0106
7	Rocker Switch	1	32D0232	32D0232
8	Cord Set Assembly	1	26D0619	26D0619
9	Motor Assembly	2	077996	077996
10	Fan Base Bracket	2	029935	029935
11	Adjustable Spring Clip	2	037088	037088
12	Spring Door Closure	1	037416	037416
13	Glass Panel	4	61D0002	61D0004
14	Right Door Assembly*	1	61D0123	61D0127
15	Left Door Assembly*	1	61D0124	61D0128
16	Glass Spring Retainer	16	037085	037085
17	Pivot Bushing	2	075899	075899
18	Handle Package Assembly	1	069458	069458
19	Grate Retainer	2	61D0038	61D0038
20	Retainer Clip	2	61D0009	61D0009
21	Nail Down Strap	2	023762	023762
22	Safety Metal Strip	2	61D0086	61D0086

* Complete with glass panels and bi-fold trim
Black finish only

REPLACEMENT PARTS

REPLACEMENT PARTS ARE AVAILABLE THROUGH YOUR RETAILER

REPLACEMENT PARTS

Item	Part No.	Description
1	SE30	Elbow offset/return package containing two 8" diameter 30° elbows
2	612	0 to 6/12 variable pitch roof flashing for contemporary installation; one 612 flashing required with SC round chimney cap on 0 to 6/12 pitch roof
3	SC	Round chimney cap for contemporary installation; includes storm collar
4	H1652	16"x52" hearth extension for protecting floor against sparks and radiant heat
4	H2066	20"x66" hearth extension for protecting floor against sparks and radiant heat
5	FP6U	6" diameter x 8' long flexible uninsulated combustion air duct (Use with AK6 kit)
6	603	6" duct connector for splicing FP6U ducts; includes one connector and two clamps
7	S48	48" long x 8" diameter chimney flue section
7	S36	36" long x 8" diameter chimney flue section
7	S18	18" long x 8" diameter chimney flue section
7	S12	12" long x 8" diameter chimney flue section
8	SVTR	Thimble to pass chimney through 14 1/2" x 14 1/2" ceiling opening. Swivels 0° to 15°
9	SVTE	Thimble extension for use with SVTR thimble as needed

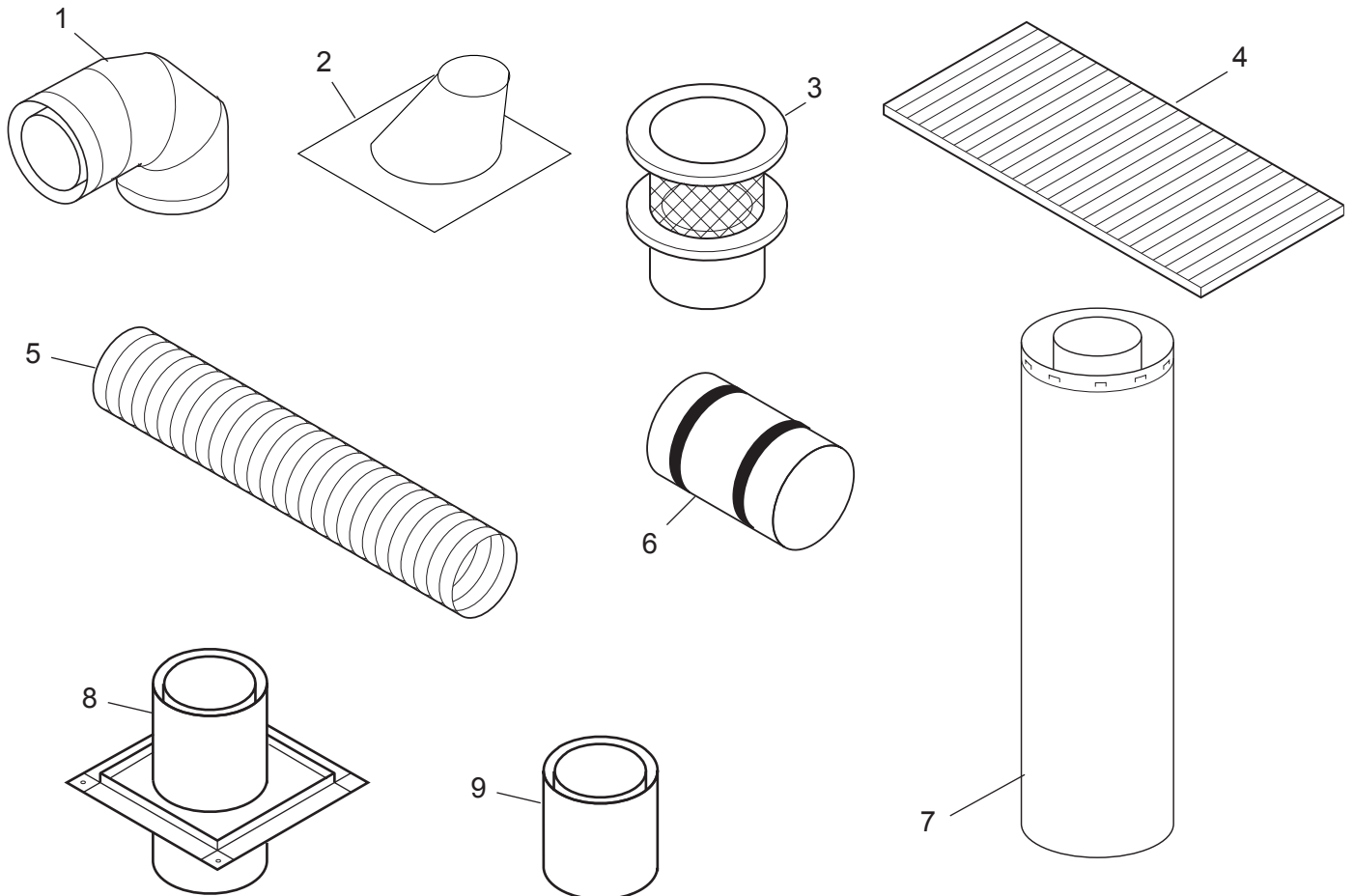

NOTES

ATTENTION APPLIANCE INSTALLER

**PLEASE RETURN THESE
OPERATING AND
INSTALLATION
INSTRUCTIONS
TO THE CONSUMER!**

LIMITED WARRANTY
FACTORY-BUILT FIREPLACE AND COMPONENTS
(EXCEPT BLOWERS)

WHAT IS COVERED AND FOR HOW LONG

- **Five-Year Coverage:** For five years from the date this fireplace and components are first purchased for use, Monessen Hearth Systems will, at its option, repair or replace any defective part of this fireplace or components, or refund to you a sum not to exceed the factory retail price in effect at the time of purchase.
- **Ten-Year Coverage:** From the sixth through the tenth year following the date this fireplace or accessory is first purchased for use, Monessen Hearth Systems will make available to you, at our factory, a free replacement for any defective part in this fireplace or accessory.
- **Twenty-Five-Year Availability of Replacement Parts:** From the eleventh through the twenty-fifty year following the date this fireplace or accessory is first purchased for use, Monessen Hearth Systems will make available at our factory replacement parts for this fireplace or accessory, which you may purchase for the list price current at the time your purchase order is received.

WHAT IS NOT COVERED

This limited warranty does not cover:

- Transportation or shipping cost.
- The cost of a service call to diagnose trouble.
- Painted surfaces.
- Damage or defect caused by improper installation, accident, misuse, abuse or alteration.
- Poor ventilation of smoke or gases caused by air-conditioning and heating systems, exhaust fans, or pressure differentials produced by wind.
- Broken glass components
- Cracks in ceramic and castable parts that do not affect safe operation.
- We do not warrant this fireplace to be in compliance with your local building code. Building codes vary greatly throughout the country, and you should determine whether your local building code contains restrictions on the use of this fireplace before you purchase it.
- Blowers or fans, which are warranted separately.
- Heat loss due to the passage of heat or air through or around the fireplace.

Also, under our five year coverage, we do not pay the cost of removal and replacement of any portion of the structure in which the fireplace is situated, made necessary by the repair, removal or re-installation of the fireplace.

And under our twenty-five year warranty of availability of replacement parts, we only promise to maintain a supply of replacement parts at our factory for you to purchase.

LIMITATIONS AND EXCLUSIONS

1. No one has authority to add to or vary this limited warranty, or to create for Monessen Hearth Systems any other obligation of liability in connection with this fireplace and accessory.
2. Monessen Hearth Systems shall not be liable for incidental, consequential, special or contingent damages you might suffer as a result of its breach of this written warranty or any implied warranty. Some states do not allow the exclusion of limitation of incidental or consequential damages, so the above limitations may not apply to you.
3. This warranty applies only to the original purchaser of the fireplace or to the original owner of the dwelling when the fireplace is installed in a new dwelling and may not be transferred.
5. This warranty applies only to a fireplace sold and used in the United States.

For information about this warranty, contact:

Technical Services
Monessen Hearth Systems
149 Cleveland Drive
Paris, Kentucky 40361