

CombiFlexBloc

Vertical centrifugal pump in monobloc execution

CFB/EN (1212) 2.3

Original instructions

Read and understand this manual prior to operating or servicing this product



EC Declaration of conformity

(Directive 2006/42/EC, appendix II-A)

Manufacturer

SPX Flow Technology Assen B.V.
Dr. A.F. Philipsweg 51
9403 AD Assen
The Netherlands

hereby declares that all pumps member of productfamilies CombiBloc, CombiBlocHorti, CombiChem, CombiDirt, CombiFlex(U)(B), CombiPrime H, CombiLine, CombiLineBloc, CombiMag, CombiMagBloc, CombiNorm, CombiPro(M)(V), CombiPrime V, CombiSump, CombiWell, FRE, FRES, FREF, FREM, KGE(L), KGEF, HCR, MCH(W)(S), MCHZ(W)(S), MCV(S), PHA, MDR whether delivered without drive (last position of serial number = B), or delivered as an assembly with drive (last position of serial number = A), are in conformity with the provisions of Directive 2006/42/EC (as altered most recently) and where applicable the following directives and standards:

- EC directive 2006/95/EG, "Electric equipment for use within certain voltage limits"
- standards EN-ISO 12100 part 1 & 2, EN 809

The pumps to which this declaration refers may only be put into operation after they have been installed in the way prescribed by the manufacturer, and, as the case may be, after the complete system of which these pumps form part, has been made to fulfil the requirements of Directive 2006/42/EC (as altered most recently).

Declaration of incorporation

(Directive 2006/42/EC, appendix II-B)

Manufacturer

SPX Flow Technology Assen B.V.
Dr. A.F. Philipsweg 51
9403 AD Assen
The Netherlands

hereby declares that the partly completed pump (Back-Pull-Out unit), member of productfamilies CombiBloc, CombiBlocHorti, CombiChem, CombiDirt, CombiFlex(U)(B), CombiPrime H, CombiLine, CombiLineBloc, CombiMag, CombiMagBloc, CombiNorm, CombiPro(M)(V), CombiPrime V, FRE, FRES, FREF, FREM, KGE(L), KGEF, HCR, PHA, MDR is in conformity with the following standards:

- EN-ISO 12100 parts 1 & 2, EN 809

and that this partly completed pump is meant to be incorporated into the specified pump unit and may only be put into use after the complete machine of which the pump under consideration forms part has been made and declared to comply with that directive.

Assen, January 1st 2011

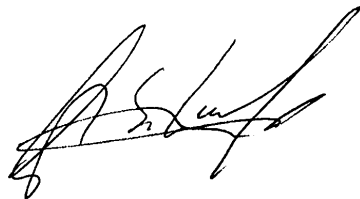

G.A. Schaafsma,
General Manager

Instruction manual

All technical and technological information in this manual as well as possible drawings made available by us remain our property and shall not be used (otherwise than for the operation of this pump), copied, duplicated, made available to or brought to the notice of third parties without our prior written consent.

SPX is a Fortune 500, global multi-industry manufacturing leader. SPX divides its business into four segments and one of these is the SPX Flow Technology segment. SPX Flow Technology Assen B.V. is part of SPX Flow Technology segment.

SPX Flow Technology Assen B.V.
P.O. Box 9
9400 AA Assen
The Netherlands
Tel. +31 (0)592 376767
Fax. +31 (0)592 376760

Copyright © 2008 SPX Corporation

Table of Contents

1	Introduction	9
1.1	Preface	9
1.2	Safety	9
1.3	Guarantee	10
1.4	Inspection of delivered items	10
1.5	Instructions for transport and storage	10
1.5.1	Dimensions and weight	10
1.5.2	Use of pallets	10
1.5.3	Hoisting	11
1.5.4	Storage	11
1.6	Ordering parts	12
2	General	13
2.1	Pump description	13
2.2	Type code	13
2.3	Serial number	14
2.4	Applications	14
2.5	Construction	14
2.5.1	Design	14
2.5.2	Pump casing/impeller/suction bend	14
2.5.3	Shaft sealing	14
2.5.4	Bearing construction	14
2.5.5	Foot pads	15
2.6	Application area	15
2.7	Re-use	15
2.8	Scrapping	15
3	Installation	17
3.1	Safety	17
3.2	Preservation	17
3.3	Environment	17
3.4	Installation of a pump unit	17
3.5	Piping	18
3.6	Accessories	18
3.7	Connecting the electric motor	18
4	Commissioning	19
4.1	Inspection of the pump	19
4.2	Inspection of the motor	19
4.3	Preparing the unit for commissioning	19

4.4	Checking the sense of rotation	19
4.5	Start-up	19
4.6	Adjustment of shaft sealing	20
4.6.1	Stuffing box packing	20
4.6.2	Mechanical seal	20
4.7	Pump in operation	20
4.8	Noise	20
5	Maintenance	21
5.1	Regular maintenance	21
5.2	Shaft sealing	21
5.2.1	Stuffing box packing	21
5.2.2	Mechanical seal	21
5.3	Lubrication of the bearings	21
5.4	Environmental influences	21
5.5	Noise	22
5.6	Motor	22
5.7	Faults	22
6	Problem solving	23
7	Disassembly and assembly	25
7.1	Precautionary measures	25
7.2	Special tools	25
7.3	Liquid draining	25
7.4	Disassembly and assembly Top Pull Out unit	26
7.4.1	Disassembly Top Pull Out unit	26
7.4.2	Assembly Top Pull Out unit	26
7.5	Replacing the impeller and the wear ring	27
7.5.1	Disassembling of the impeller	27
7.5.2	Mounting the impeller	27
7.5.3	Disassembling the wear ring	28
7.5.4	Assembling the wear ring	28
7.6	Stuffing box packing S2, S3, S4	29
7.6.1	Instruction for assembling and disassembling stuffing box packing	29
7.6.2	Replacing the stuffing box packing S2, S3, S4	30
7.6.3	Mounting a new stuffing box packing S2, S3, S4	30
7.6.4	Disassembling the shaft sleeve	31
7.6.5	Mounting the shaft sleeve	31
7.7	Mechanical seal	32
7.7.1	Instructions for mounting a mechanical seal	32
7.7.2	Disassembling a mechanical seal M0	33
7.7.3	Assembling a mechanical seal M0	33
7.7.4	Disassembling a mechanical seal M1	34
7.7.5	Assembling a mechanical seal M1	34
7.7.6	Disassembling a mechanical seal M2-M3	35
7.7.7	Assembling a mechanical seal M2-M3	36
7.7.8	Removing the electric motor	36
7.7.9	Mounting the electric motor	36
7.8	Replacing the stub shaft and the motor for M0	37
7.8.1	Disassembling the stub shaft and the motor	37
7.8.2	Assembling the stub shaft and the motor	38
8	Dimensions	39
8.1	Dimensions delivery flange	39
8.2	Dimensions suction flange	40

8.3	Dimensions foot pads K1	40
8.4	Pump dimensions K1, with suction bend	41
8.4.1	Pump dimensions M0	42
8.4.2	Pump dimensions S2/S3/S4/M1/M2/M3	43
8.5	Pump dimensions K3, with suction bend	44
8.5.1	Pump dimensions M0	45
8.5.2	Pump dimensions S2/S3/S4/M1/M2/M3	46
9	Parts	47
9.1	Ordering parts	47
9.1.1	Order form	47
9.1.2	Recommended spare parts	47
9.2	Pump construction K1	48
9.2.1	Sectional drawing M0	48
9.2.2	Parts list M0	49
9.2.3	Sectional drawing M1/M2/M3/S2/S3/S4	50
9.2.4	Parts list M1/M2/M3/S2/S3/S4	51
9.3	Pump construction K3	52
9.3.1	Sectional drawing M1/M2/M3/S2/S3/S4	52
9.3.2	Parts list M1/M2/M3/S2/S3/S4	53
9.4	Stuffing box packing S2-S3	54
9.4.1	Stuffing box packing S2-S3	54
9.4.2	Parts list stuffing box packing S2-S3	54
9.5	Stuffing box packing S4	55
9.5.1	Stuffing box packing S4	55
9.5.2	Parts list stuffing box packing S4	55
9.6	Shaft sealing group M1	56
9.6.1	Mechanical seal MG12-G60	56
9.6.2	Parts list mechanical seal MG12-G60	56
9.7	Shaft sealing group M2-M3	57
9.7.1	Mechanical seal M7N-H7N	57
9.7.2	Parts list mechanical seal M7N-H7N	57
9.8	Suction bend K1/K3	58
9.8.1	Sectional drawing suction bend, K1	58
9.8.2	Parts of suction bend, K1	58
9.8.3	Sectional drawing suction bend, K3	59
9.8.4	Parts of suction bend, K3	59
10	Technical data	61
10.1	Bearing groups	61
10.2	The pump range is divided in a number of bearing groups.	61
10.3	Mounting media	61
10.3.1	Recommended mounting grease	61
10.3.2	Recommended locking liquids	61
10.4	Tightening moments	62
10.4.1	Tightening moments for bolts and nuts	62
10.4.2	Tightening moments for cap nut	62
10.5	Maximum speed	62
10.6	Pressure in shaft sealing space for shaft sealing groups M1-M2-M3	63
10.7	Pressure near the impeller hub for shaft sealing groups S2-S3-S4	64
10.8	Hydraulic performance	65
10.9	Noise data	67
10.9.1	Pump noise as a function of pump power	67
10.9.2	Noise level of entire pump unit	68
	Index	69

1 Introduction

1.1 Preface

This manual is intended for technicians and maintenance staff and for those who are in charge of ordering spare parts.

This manual contains important and useful information for the proper operation and maintenance of this pump. It also contains important instructions to prevent potential accidents and damage, and to ensure safe and fault-free operation of this pump.



Read this manual carefully before commissioning the pump, familiarize yourself with the operation of the pump and strictly obey the instructions!

The data published here comply with the most recent information at the time of going to press. However they may be subject to later modifications.

SPX reserves the right to change the construction and design of the products at any time without being obliged to change earlier deliveries accordingly.

1.2 Safety

This manual contains instructions for working safely with the pump. Operators and maintenance staff must be familiar with these instructions.

Installation, operation and maintenance has to be done by qualified and well prepared personnel.

Below is a list of the symbols used for those instructions and their meaning:



Personal danger for the user. Strict and prompt observance of the corresponding instruction is imperative!



Risk of damage or poor operation of the pump. Follow the corresponding instruction to avoid this risk.



Useful instruction or tip for the user.

Items which require extra attention are shown in **bold print**.

This manual has been compiled by SPX with the utmost care. Nevertheless SPX cannot guarantee the completeness of this information and therefore assumes no liability for possible deficiencies in this manual. The buyer/user shall at all times be responsible for testing the information and for taking any additional and/or deviating safety measures. SPX reserves the right to change safety instructions.

1.3 Guarantee

SPX shall not be bound to any guarantee other than the guarantee accepted by SPX. In particular, SPX will not assume any liability for explicit and/or implicit guarantees such as but not limited to the marketability and/or suitability of the products supplied.

The guarantee will be cancelled immediately and legally if:

- Service and/or maintenance is not undertaken in strict accordance with the instructions.
- The pump is not installed and operated in accordance with the instructions.
- Necessary repairs are not undertaken by our personnel or are undertaken without our prior written permission.
- Modifications are made to the products supplied without our prior written permission.
- The spare parts used are not original SPX parts.
- Additives or lubricants used are other than those prescribed.
- The products supplied are not used in accordance with their nature and/or purpose.
- The products supplied have been used amateurishly, carelessly, improperly and/or negligently.
- The products supplied become defective due to external circumstances beyond our control.

All parts which are liable to wear are excluded from guarantee. Furthermore, all deliveries are subject to our "General conditions of delivery and payment", which will be forwarded to you free of charge on request.

1.4 Inspection of delivered items

Check the consignment immediately on arrival for damage and conformity with the advice note. In case of damage and/or missing parts, have a report drawn up by the carrier at once.

1.5 Instructions for transport and storage

1.5.1 Dimensions and weight

A pump or a pump unit is generally too heavy to be moved by hand. Therefore, use the correct transport and lifting equipment. Dimensions and weight of the pump or pump unit are shown on the label on the cover of this manual.

1.5.2 Use of pallets

Usually a pump or pump unit is shipped on a pallet. Leave it on the pallet as long as possible to avoid damages and to facilitate possible internal transport.



When using a forklift always set the forks as far apart as possible and lift the package with both forks to prevent it from toppling over! Avoid jolting the pump when moving it!

1.5.3 Hoisting

When hoisting a pump or complete pump units the straps must be fixed in accordance with figure 1.



When lifting a pump or a complete pump unit always use a proper and sound lifting device, approved to bear the total weight of the load!



Never go underneath a load that is being lifted!



If the electric motor is provided with a lifting eye, this lifting eye is intended only for the purpose of carrying out service activities to the electric motor! The lifting eye is designed to bear the weight of the electric motor only! It is NOT permitted to lift a complete pump unit at the lifting eye of an electric motor!

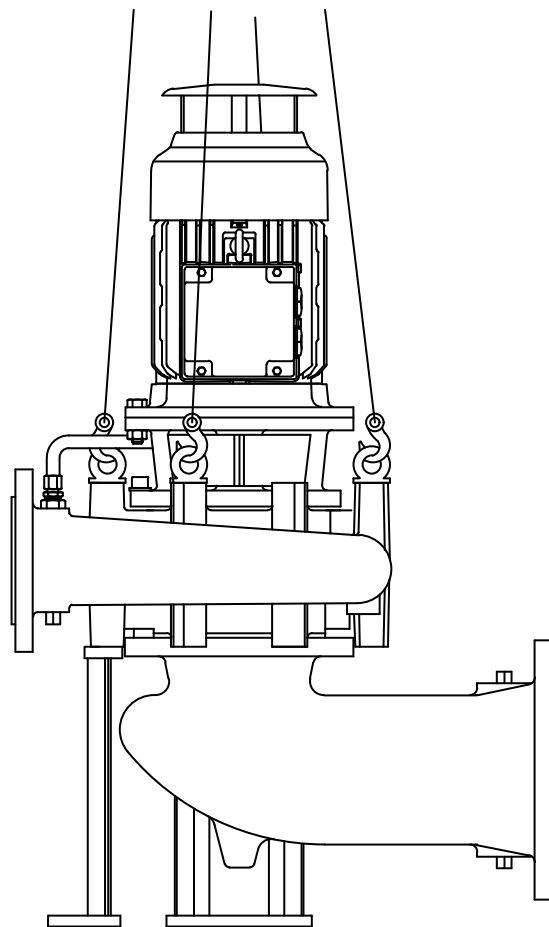

Figure 1: Lifting instructions for pump unit.

1.5.4 Storage

If the pump is not to be used immediately the stub shaft must be turned by hand twice per week.

1.6 **Ordering parts**

This manual contains a survey of the spare parts recommended by SPX as well as the instructions for ordering them. A fax-order form is included in this manual.

You should always state all data stamped on the type plate when ordering parts and in any other correspondence regarding the pump.

➤ *This data is also printed on the label on the front of this manual.*

If you have any questions or require further information with regard to specific subjects, then do not hesitate to contact SPX.

2 General

2.1 Pump description

The CombiFlexBloc is a range of vertical non-self-priming centrifugal pumps. The discharge and suction connection can be mounted in different positions in relation to each other. The pump is driven by a vertical flange motor with extended motor shaft. There is also a version with a IEC-standard flange motor and a stub shaft. The pump and the electric motor are assembled as a compact unit by means of a lantern piece. The impeller is mounted directly to the motor shaft/stub shaft. Because of their modular layout, constructional components are widely interchangeable, also with other pump types of the Combi system.

2.2 Type code

Pumps are available in various designs. The main characteristics of the pump are shown in the type code.

Example: **CFB 40-200 G1 M1 K1**

Pump family	
CFB	CombiFlexBloc
Pump size	
40-200	diameter discharge connection [mm] - nominal impeller diameter [mm]
Pump casing material	
G	cast iron
B	bronze
Impeller material	
1	cast iron
2	bronze
3	aluminium bronze
Shaft sealing	
S2	stuffing box packing, with shaft sleeve
S3	stuffing box packing, with shaft sleeve and lantern ring
S4	stuffing box packing, with shaft sleeve and cooling jacket
M0	mechanical seal, unbalanced, stub shaft
M1	mechanical seal, unbalanced
M2	mechanical seal, unbalanced, shaft sleeve
M3	mechanical seal, balanced, shaft sleeve
Foot pads	
K1	profiled steel elements
K3	tubular construction with opening for suction bend

2.3 Serial number

Serial number of the pump or pump unit are shown on the name plate off the pump and on the label on the cover of this manual.

Example: **01-1000675A**

01	year of manufacture
100067	unique number
5	number of pumps
A	pump with motor
B	pump with free shaft end

2.4 Applications

- In general, this pump can be used for thin, clean or slightly polluted liquids. These liquids should not affect the pump materials.
- Further details about the application possibilities of your specific pump are mentioned in the order confirmation and/or in the data sheet enclosed with the delivery.
- Do not use the pump for purposes other than those for which it is delivered without prior consultation with your supplier.



Using a pump in a system or under system conditions (liquid, working pressure, temperature, etc.) for which it has not been designed may hazard the user!

2.5 Construction

2.5.1 Design

The design is characterized by a compact construction. The pump is mounted to a vertical flange motor by means of a lantern piece and stub shaft or a special electric motor with an extended shaft. The pump cover is clamped between the pump casing and the lantern piece.

The main components are described below:

2.5.2 Pump casing/impeller/suction bend

These are the parts that get into contact with the pumped liquid. For each individual pump type there is only one construction of the pump casing and the impeller. The pump casing and the suction bend are available in cast iron and in bronze, the impeller in cast iron, bronze and aluminium bronze. The stub shaft is made of stainless steel. The square suction bend has been designed in such a way that resistance is low and that all the same a low position of the pump in relation to the floor is possible.

2.5.3 Shaft sealing

The shaft seal is available in various variants. There are 3 constructions with a stuffing box, for instance with a water-cooled cover, and there are 4 constructions with a mechanical seal, both unbalanced and balanced.

2.5.4 Bearing construction

The pump shaft bearing is provided by the motor bearings. The selection of the pump/motor combination is such that the bearings of the applied electric motors can absorb the axial and radial forces without the bearing life being affected. The electric motors must be provided with a **fixed bearing**.

2.5.5 Foot pads

The foot pads consist of profiled steel elements or of a tubular construction with an opening for the passage of the suction bend

2.6 Application area

The application area globally looks as follows:

Table 1: Application area.

	Maximum value
Capacity	720 m ³ /h
Discharge head	105 m
System pressure	10 bar
Temperature	110 °C

However, the maximum allowable pressures and temperatures depend strongly on the selected materials and components. Also working conditions may cause differences. For more detailed information see chapter 10 "Technical data".

2.7 Re-use

The pump may only be used for other applications after prior consultation with SPX or your supplier. Since the lastly pumped medium is not always known, the following instructions should be observed:

- 1 Flush the pump properly.
- 2 Make sure the flushing liquid is discharged safely (environment!)



Take adequate precautions and use the appropriate personal protection means like rubber gloves and spectacles!

2.8 Scrapping

If it has been decided to scrap a pump, the same flushing procedure as described for Re-use should be followed.

3 Installation

3.1 Safety

- Read this manual carefully prior to installation and commissioning. Non-observance of these instructions can result in serious damage to the pump and this will not be covered under the terms of our guarantee. Follow the instructions given step by step.
- Ensure that the pump can not be started if work has to be undertaken to the pump during installation and the rotating parts are insufficiently guarded.
- Depending on the design the pumps are suitable for liquids with a temperature of up to 110°C. When installing the pump unit to work at 65°C and above the user should ensure that appropriate protection measures and warnings are fitted to prevent contact with the hot pump parts.
- If there is danger of static electricity, the entire pump unit must be earthed.
- If the pumped liquid is harmful to men or the environment, take appropriate measures to drain the pump safely. Possible leakage liquid from the shaft seal should also be discharged safely.

3.2 Preservation

In order to prevent corrosion, the inside of the pump is treated with a preserving agent before leaving the factory.

Before commissioning the pump remove any preserving agents and flush the pump thoroughly with hot water.

3.3 Environment

- The foundation must be hard, level and flat.
- The area in which the pump is installed must be sufficiently ventilated. An ambient temperature or air humidity which is too high, or a dusty environment, can have a detrimental effect on the operation of the electric motor.
- There should be sufficient space around the pump unit to operate and if necessary repair it.
- Above the cooling air inlet of the motor there must be a free area of at least 1/4 of the electric motor diameter, to ensure unobstructed air supply.

3.4 Installation of a pump unit

If the unit is delivered as a complete set, pump and motor are assembled in the works. In that case the impeller has already been properly adjusted axially. In case of permanent arrangement, level the pump on the foundation by means of shims and carefully tighten the nuts of the foundation bolts.

3.5 Piping

- The piping to the suction and delivery connections must fit exactly and must not be subject to stress during operation.
- The passage of the suction pipe must be amply dimensioned. This pipe should be as short as possible and run towards the pump in such a way that no air pockets can arise. If this is not possible, a venting facility should be provided at the highest point of the pipe.
- If the inside diameter of the suction pipe is larger than the suction connection of the pump, an eccentric reducer should be applied to prevent air pockets and whirls. See figure 2

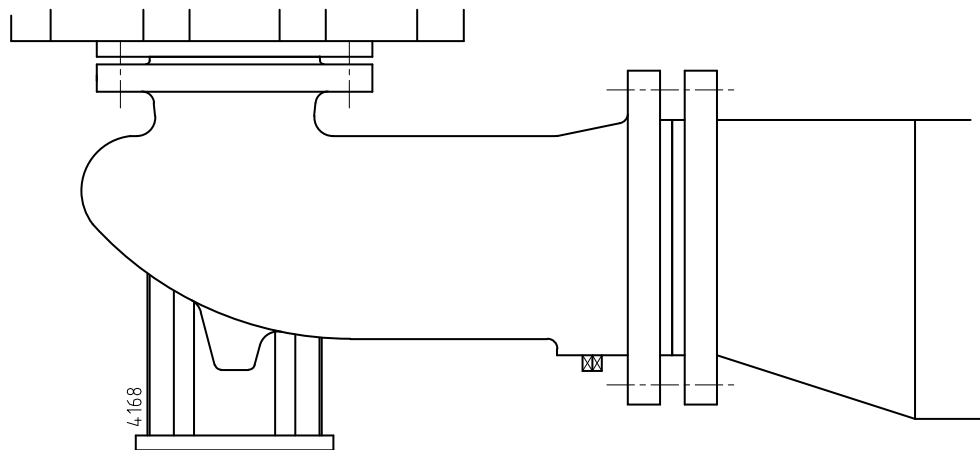

Figure 2: Eccentric reducer to suction flange.

- Sudden changes in the rate of flow can lead to high pressure impulses in the pump and the piping (water shock). Therefore, do not use quick-acting closing devices, valves etc.

3.6 Accessories

- Fit any parts that may have been supplied separately.
- If necessary, mount a foot valve at the bottom of the suction pipe. Combine this foot valve with a suction strainer to prevent impurities from being drawn in.
- When mounting, place temporarily (for the first 24 operating hours) a fine gauze between suction flange and suction pipe to prevent internal pump parts from being damaged by foreign matter. If the risk of damage continues to exist, fit a permanent filter.
- In case the pump is provided with an isolation, special attention has to be paid To temperature limits of shaft seal and bearing.

3.7 Connecting the electric motor



The electric motor must be connected to the mains by an approved electrician, according to the locally prevailing regulations of the electricity company.

- Refer to the instruction manual belonging to the electric motor.
- If possible, fit a working switch as close as possible to the pump.

4 Commissioning

4.1 Inspection of the pump

- Construction with stuffing box packing: Remove the seal guards (0270). Check whether the nuts (1810) have not been over tightened. If necessary, loosen these nuts and tighten them again by hand. Fit the seal guards (0270).
- Check whether the stub shaft turns freely. Do this by turning the shaft end at the coupling a few times by hand.

4.2 Inspection of the motor

Check whether the fuses have been mounted.

4.3 Preparing the unit for commissioning

Proceed as follows, both when the unit is put into operation for the first time and after the pump has been overhauled:

- 1 Fully open the stop valve in the suction pipe. Close the delivery stop valve.
- 2 Fill the pump and the suction pipe with the liquid to be pumped.
- 3 Turn the pump shaft a few times by hand and add more liquid, if necessary.

4.4 Checking the sense of rotation



Beware of possible non-screened rotating parts, when checking the sense of rotation!

- 1 The sense of rotation of the pump is indicated by an arrow. Check whether the sense of rotation of the motor corresponds with that of the pump.
- 2 Let the motor run for only a short time and check the sense of rotation.
- 3 If the sense of rotation is **not** correct, alter the sense of rotation. See the instructions in the user manual belonging to the electric motor.
- 4 Fit the guard.

4.5 Start-up

- 1 Open the stop valves in the supply and return lines for flushing or cooling liquid, if the pump is connected to a flushing or cooling system.
- 2 Start the pump.
- 3 As soon as the pump is under pressure, slowly open the delivery stop valve until the working pressure is attained.



Make sure that when a pump is running, rotating parts are always properly screened the guard!

4.6 Adjustment of shaft sealing

4.6.1 Stuffing box packing

After the pump is started, the stuffing box packing will show a certain amount of leakage. Because of the expansion of the packing fibres, this leakage will gradually decrease. Make sure that the stuffing box packing never runs dry. To prevent this, loosen the nuts (1810) to the extent that the stuffing box packing leaks by drops. As soon as the pump has reached the proper temperature (and leakage is still too much) the gland can be adjusted permanently:

- 1 Tighten both nuts, one after the other, a quarter turn.
- 2 Wait 15 minutes after each adjustment before making the next adjustment.
- 3 Continue in this way until an acceptable leakage by drops has been attained (10/20 cm³/h).
- 4 Fix the seal guards (0270).



Adjustment of stuffing box packing has to be done with running pump. Take great care not to touch moving parts.

4.6.2 Mechanical seal

- A mechanical seal may never show visible leakage.

4.7 Pump in operation

When the pump is in operation, pay attention to the following:

- The pump should never run dry.
- Never use a stop valve in the suction line to control pump output. The stop valve should always be fully opened during operation.
- Check whether the absolute inlet pressure is sufficient, to prevent vaporization in the pump.
- Check whether the pressure difference between suction and delivery side corresponds with the specifications of the pump's duty point.
- A mechanical seal may never show visible leakage.

4.8 Noise

The noise production of a pump depends to a great extent on the operating conditions. The values stated in paragraph 10.9 "Noise data" are based on normal operation of the pump, driven by an electric motor. In case the pump is driven by a combustion engine, or in case it is used outside the normal operation area, as well as in case of cavitation, the noise level may exceed 85 dB(A). In that case precautions should be taken, like building a noise-barrier around the unit or wearing hearing protection.

5 Maintenance

5.1 Regular maintenance

Regularly check the outlet pressure.



No water should get into the terminal box of the electric motor when the pump room is sprayed clean!

Never spray water on hot pump parts! The sudden cooling down may cause them to burst and hot water may flow out!



Flawed maintenance will result in shorter lifespan, possible break down and in any event loss of warranty.

5.2 Shaft sealing

5.2.1 Stuffing box packing

Do not tighten the nuts (1810) any more after the running-in period and adjustment. If in time the stuffing box packing starts to leak excessively, new packing rings have to be mounted instead of further tightening the nuts!

5.2.2 Mechanical seal

A mechanical seal generally requires no maintenance, however, **it should never be allowed to run dry**. If there are no problems, do not dismantle the mechanical seal. As the seal faces have run in on one another dismantling usually implicates replacement of the mechanical seal. If a mechanical seal shows any leakage it has to be replaced.

5.3 Lubrication of the bearings

For maintenance of the motor bearings we refer to the instructions of the motor supplier concerned.

5.4 Environmental influences

- Regularly clean the filter in the suction pipe or the suction strainer at the bottom of the suction pipe, as the inlet pressure may become too low if the filter or the suction strainer is fouled.
- If there is a risk that the pumped liquid expands during solidification or freezing, the pump has to be drained and, if necessary, flushed after it has been put out of service.
- If the pump is out of service for a long time, it has to be preserved.
- Check motor for accumulation of dust or dirt, which might influence motor temperature.

5.5 Noise

If a pump starts making noise, this may point to certain problems with the pump unit. A crackling noise can indicate cavitation or excessive motor noise can indicate deterioration of the bearings.

5.6 Motor

Check motor specifications for start-stop frequency.

5.7 Faults



The pump, of which you want to determine the fault, may be hot or under pressure. Take the appropriate precautions first and protect yourself with the proper safety devices (safety goggles, gloves, protective clothing)!

To determine the source of the malfunctioning of the pump, proceed as follows:

- 1 Switch off the power supply to the pump unit. Lock the working switch with a padlock or remove the fuse.
- 2 Close the stop valves.
- 3 Determine the nature of the fault.
- 4 Try to determine the cause of the fault with chapter 6 "Problem solving" and take the appropriate measures or contact your installer.

6 Problem solving

Faults in a pump installation can have various causes. The fault may not be in the pump, it may also be caused by the pipe system or the operating conditions. Firstly, always check that installation has been executed in accordance with the instructions in this manual and that the operating conditions still correspond with the specifications for which the pump was purchased.

In general, breakdowns in a pump installation are attributable to the following causes:

- Faults with the pump.
- Breakdowns or faults in the pipe system.
- Faults due to incorrect installation or commissioning.
- Faults due to incorrect choice of pump.

A number of the most frequently occurring failures as well as their possible causes are shown in the table below.

Table 2: Most frequently occurring failures.

Most common faults	Possible causes, see Table 3.
Pump delivers no liquid	1 2 3 4 5 6 7 8 9 10 11 13 14 17 19 20 21 29
Pump has insufficient volume flow	1 2 3 4 5 6 7 8 9 10 11 13 14 15 17 19 20 21 28 29
Pump has insufficient head	2 4 5 13 14 17 19 28 29
Pump stops after start up	1 2 3 4 5 6 7 8 9 10 11
Pump has higher power consumption than normal	12 15 16 17 18 22 24 25 26 27 32 34 38
Pump has lower power consumption than normal	13 14 15 16 17 18 20 21 28 29
The stuffing box is leaking excessively	6 7 25 26 30 31 32 33 43
Packing rings or mechanical seal have to be replaced to often	25 26 30 32 33 36 41
Pump vibrates or is noisy	1 9 10 11 15 18 19 20 22 23 24 25 26 27 29 37 38
Bearings wear too much or become hot	24 25 26 27 37 38 42
Pump running rough hot or seizes	24 25 26 27 34 37 38 42

Table 3: Possible causes of pump failures.

	Possible causes
1	Pump or suction pipe is not sufficiently filled or de-aerated
2	Gas or air coming from the liquid
3	Air lock in the suction pipe
4	Air leak in the suction pipe
5	The pump takes in air through the stuffing box packing
6	The flush or quench water line to the stuffing box packing is not connected or obstructed
7	The lantern ring in the stuffing box packing has been mounted wrongly
8	The manometric suction head is too high
9	Suction pipe or suction strainer is blocked
10	Insufficient immersion of foot valve or suction pipe during operation of the pump
11	NPSH available too low
12	Speed too high
13	Speed too low
14	Wrong sense of rotation
15	Pump does not operate at the right duty point
16	Liquid density differs from the calculated liquid density
17	Liquid viscosity differs from the calculated liquid viscosity
18	Pump operates when the liquid flow is too low
19	Wrong pump selection
20	Obstruction in impeller or pump casing
21	Obstruction in the piping
22	Wrong installation of the pump unit
24	Rotating part running out of true
25	Imbalance in rotating parts (for instance: impeller or pump shaft)
26	Pump shaft is running out of true
27	Bearings faulty or worn out
28	Wear ring faulty or worn out
29	Damaged impeller
30	Pump shaft or shaft sleeve on the spot of the packing rings or seal faces of the mechanical seal are worn out or damaged
31	Worn out or dried out packing rings
32	Not well packed stuffing box packing or bad mounting of the mechanical seal
33	Stuffing box packing type or mechanical seal not suitable for the pumped liquid or operation circumstances
34	Gland or mechanical seal cover has been tightened too much or crookedly
35	No water cooling of packing rings at high temperatures
36	Quenching or flushing liquid to the packing rings or the mechanical seal is polluted
37	Axial retaining of impeller or pump shaft is defective
41	Impurities in the liquid get into the stuffing box packing
42	Too high axial force because of worn dorsal blades or excessive inlet pressure
43	Excessive pressure in stuffing box packing space due to too much play in the throttling bush, blocked by-pass or worn dorsal blades

7 Disassembly and assembly

7.1 Precautionary measures



Take adequate measures to avoid that the motor is started while you are working on the pump. This is especially important for electric motors with remote control:

- Switch the operating switch near the pump (if available) to "OFF".
- Switch off the pump switch on the switchboard.
- If necessary remove the fuses.
- Hang a danger board near the switchboard cabinet.

7.2 Special tools

Assembly and disassembly work requires no special tools. However, such tools can make certain jobs easier, for instance replacing the shaft seal. If such is the case it will be indicated in the text.

7.3 Liquid draining



Make sure no liquid gets into the environment!

Before starting any disassembly the pump should be drained through the drain plug (0320). If possible, also drain the suction bend to a certain extent (if provided with a suction bend (0400) through drain plug (0350)). Wherever necessary, first close possible valves in the suction and delivery pipe. If the pump processes harmful liquids, take the following precautions:

- 1 Wear protective gloves, shoes, glasses, etc.
- 2 Flush the pump properly.
- 3 Make sure no liquid gets into the environment.
- 4 Refit the drain plug.

7.4 Disassembly and assembly Top Pull Out unit

- *The Top Pull Out unit and the electric motor of large pumps are too heavy to be lifted by hand. Use appropriate hoisting equipment.*

CombiFlexBloc pumps use a Top Pull Out system. The electric motor with the lantern piece, the stuffing box cover/pump cover and the impeller can be dismantled as a whole. In this way the pump can for the most part be dismantled, without disassembling the suction and discharge lines.

7.4.1 Disassembly Top Pull Out unit

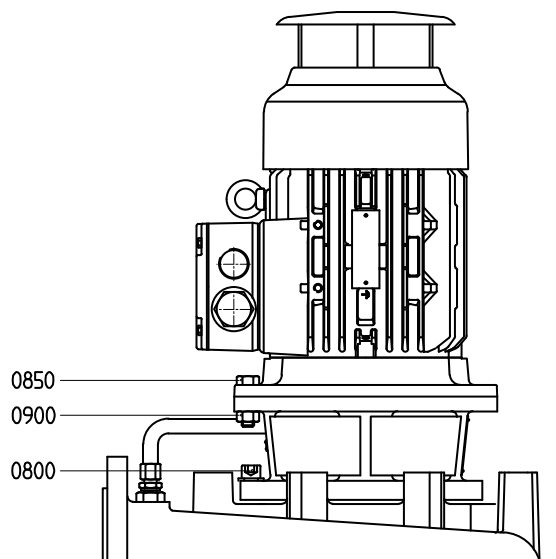

Figure 3: Disassembly Top Pull Out unit.

- 1 Open the terminal box and loosen the wires.
- 2 Remove the guards (0270).
- 3 In case of a water cooled stuffing box (S4): Disconnect the cooling water supply line to the stuffing box.
- 4 Disconnect the cooling water supply lines (1420) to the stuffing box cover (0110).

! **NEVER start dismantling by loosening the motor bolts (0850) and nuts (0900). This may result in irreparable damage to the mechanical seal and the impeller!**

- 5 Remove the Allen screws (0800).
- 6 Pull the motor together with the entire lantern piece out of the pump casing. The Top Pull Out unit large pumps is very heavy. Support it with a beam or hang it in a pulley sling.

7.4.2 Assembly Top Pull Out unit

- 1 Mount a new gasket (0300) for the pump casing and lower the Top Pull Out unit in the right position into the pump casing. Take care not to damage the gasket (0300).
- 2 Tighten the Allen screws (0800) crosswise.
- 3 Connect the quench supply line (1420) to the stuffing box cover(0110).
- 4 In case of a water cooled stuffing box (S4): Connect the cooling water supply line to the stuffing box.
- 5 Fit the guards (0270).

7.5 Replacing the impeller and the wear ring

The play between the impeller and the wear ring is 0,3 mm to the diameter at delivery. In case the play has increased to 0,5-0,7 mm due to wear, the impeller and the wear ring should be replaced.

7.5.1 Disassembling of the impeller

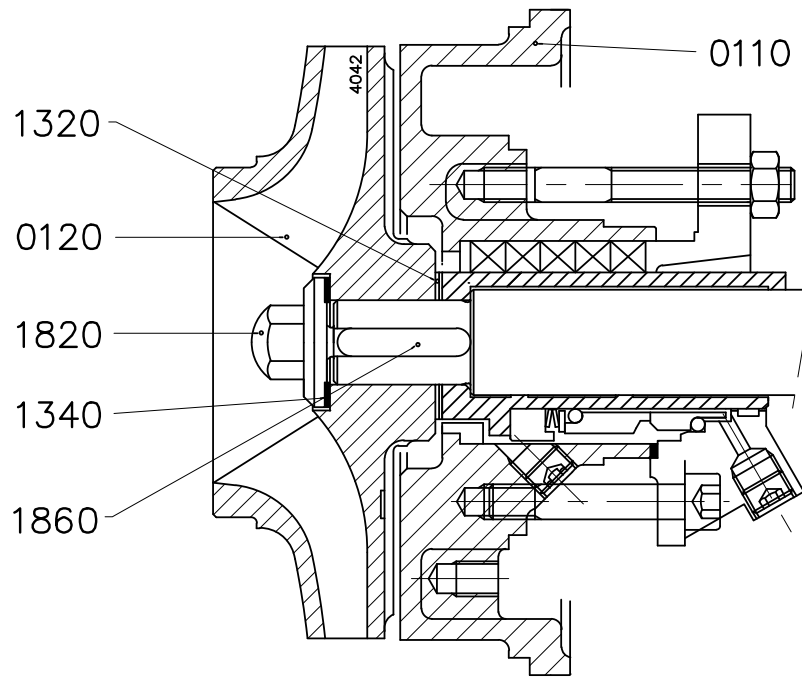

Figure 4: Disassembling of the impeller.

The item numbers used are referring to figure 4.

- 1 Remove the Top Pull Out unit, see paragraph 7.4 "Disassembly and assembly Top Pull Out unit".
- 2 Remove the cap nut (1820) and the gasket (1340). Sometimes the nut has to be heated to break the Loctite-contact.
- 3 Remove the impeller (0120) with a pulley puller, or wrest the impeller by inserting for instance 2 big screwdrivers between the impeller and the stuffing box cover (0110).
- 4 Remove the gasket (1320).
- 5 Remove the impeller key (1860).

7.5.2 Mounting the impeller

- 1 Place the impeller key (1860) in the key way of the pump shaft.
- 2 Fit the gasket (1320).
- 3 Push the impeller onto the pump shaft.
- 4 Degrease the thread on the pump shaft and the thread in the cap nut.
- 5 Fit the gasket (1340)
- 6 Put a drop of Loctite 243 on the thread and fit the cap nut. For tightening moment of the cap nut see paragraph 10.4.2 "Tightening moments for cap nut".
- 7 Mount the Top Pull Out unit, see chapter 7.4.2 "Assembly Top Pull Out unit".

7.5.3 Disassembling the wear ring

After removing the Top Pull Out unit the wear ring can be removed. In most cases the ring has been fixed so tightly that it cannot be removed undamaged.

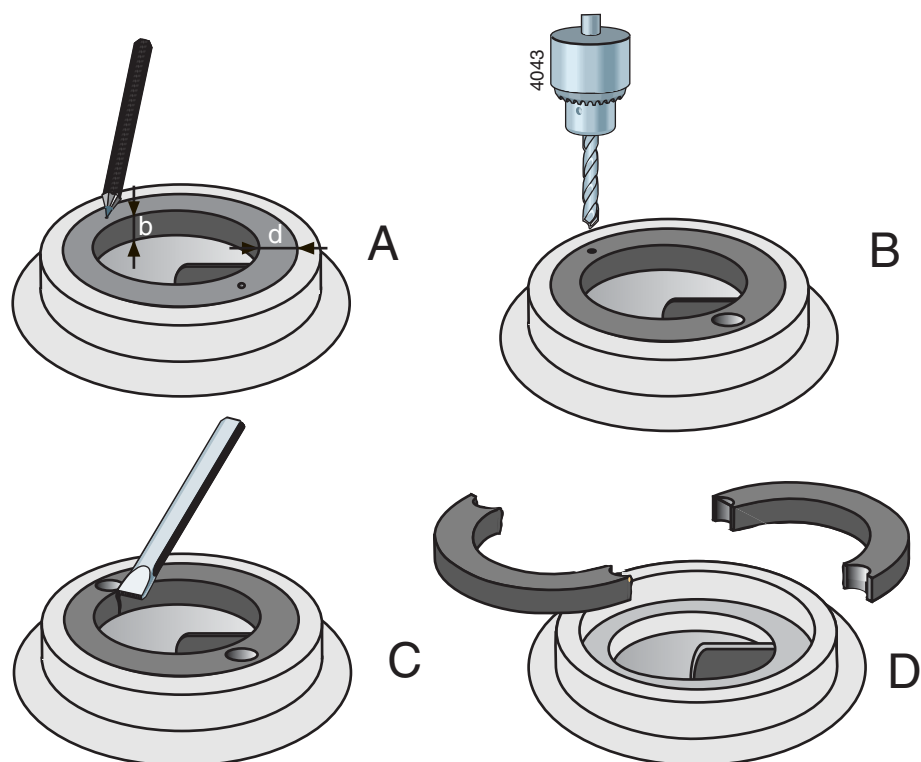

Figure 5: Removal of wear ring.

- 1 Measure the thickness (d) and the width (b) of the ring, see figure 5 A.
- 2 Make a centre hole in the middle of the edge of the ring at two opposite points, see figure 5 B.
- 3 Use a drill with a diameter just a little bit smaller than the thickness (d) of the ring and drill two holes in the ring, see figure 5 C. Don't drill deeper than the width (b) of the ring. Take care not to damage the fitting edge of the pump casing.
- 4 Use a chisel to cut the remaining part of the ring thickness. Now you can remove the ring in two parts from the pump casing, see figure 5 D.
- 5 Clean the pump casing and carefully remove all bore dust and metal splinters.

7.5.4 Assembling the wear ring

- 1 Clean and degrease the fitting edge of the pump casing where the wear ring is to be mounted.
- 2 Degrease the outer edge of the wear ring and put a few drops of Loctite 641 on it.
- 3 Fit the wear ring in the pump casing. **Take care it is not pushed out of alignment!**

7.6 Stuffing box packing S2, S3, S4

7.6.1 Instruction for assembling and disassembling stuffing box packing

➤ *First read the following instructions regarding stuffing box packing. Follow these instructions closely when removing and mounting stuffing box packing.*

- For removing old packing rings your supplier can supply a special packing puller. See figure 6.

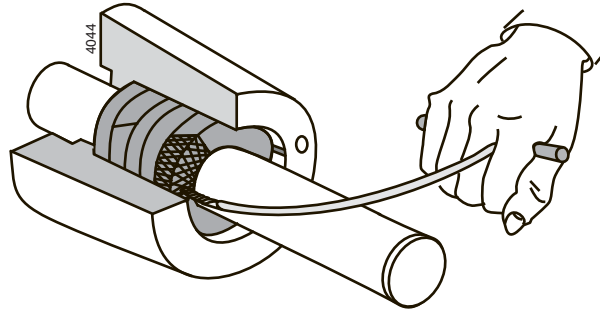

Figure 6: Removal of packing rings with a packing puller.

- Only use packing rings with the right dimensions.
- Grease the stuffing box, the shaft sleeve and the packing rings with some graphite grease or silicon grease. For the allowed grease types see paragraph 10.1 "Bearing groups".
- Bend the new packing rings open axially. See figure 7.

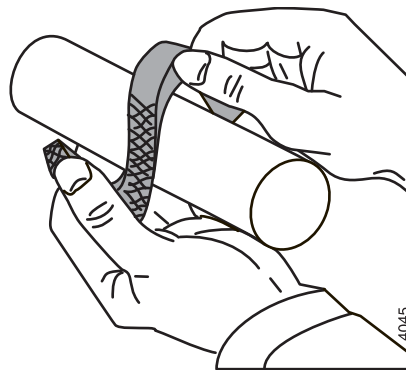

Figure 7: Axially bending open packing rings.

- For pressing the packing rings down, use a halve piece of tube with the right dimensions.

7.6.2 Replacing the stuffing box packing S2, S3, S4

To replace the stuffing box packing it is not necessary to disassemble the pump. The pump should however be drained, see paragraph 7.3 "Liquid draining".

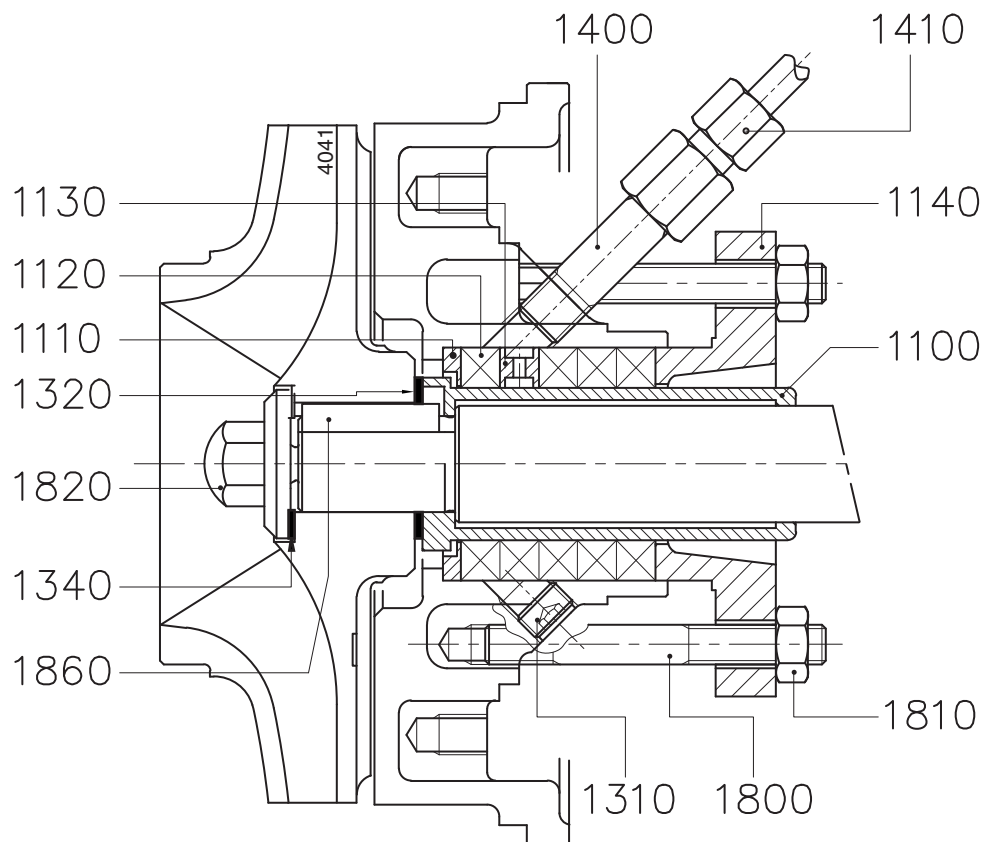

Figure 8: Stuffing box packing S2, S3 and S4.

The item numbers used are referring to figure 8.

- 1 Loosen the nuts (1810) and push the gland (1140) backward as far as possible.
- 2 Remove the old packing rings (1120) and (for S3) the lantern ring (1130).
- 3 Clean the packing space properly.
- 4 Check whether the shaft sleeve (1100) or the pump shaft (2200) is damaged. If so, you still have to disassemble the pump. Then proceed with paragraph 7.6.4 "Disassembling the shaft sleeve".

7.6.3 Mounting a new stuffing box packing S2, S3, S4

- 1 Bend the first packing ring open and put it around the shaft sleeve (1100) resp. the pump shaft (2200). Press it strongly against the bottom ring (1110) at the bottom of the stuffing box.
- 2 For S3: fit the lantern ring (1130).
- 3 Fit the subsequent rings one by one. Press them down properly. Make sure that the cuts of the rings are positioned 90° turned in relation to each other.
- 4 Press the gland against the last packing ring and tighten the nuts (1810) by turns by hand.
- 5 For adjustment of the gland see paragraph 4.6.1 "Stuffing box packing".

- 7.6.4 Disassembling the shaft sleeve
 - 1 Disassemble the impeller, see paragraph 7.5.1 "Disassembling of the impeller".
 - 2 Pull the shaft sleeve (1100) from the pump shaft.
- 7.6.5 Mounting the shaft sleeve
 - 1 Slide the shaft sleeve over the pump shaft. Watch the position of the key ways in the shaft sleeve in respect of those in the pump shaft.
 - 2 Fit the impeller and other parts, see paragraph 7.5.2 "Mounting the impeller" and paragraph 7.6.3 "Mounting a new stuffing box packing S2, S3, S4".

7.7 Mechanical seal

7.7.1 Instructions for mounting a mechanical seal

➤ *First read the following instructions regarding the mounting of a mechanical seal. Follow these instructions closely when mounting a mechanical seal.*

- **Leave the assembly of a mechanical seal with PTFE (Teflon) covered O-rings to a specialist.** These rings are easily damaged during assembly.
- A mechanical seal is a fragile precision instrument. Leave the seal in its original packing until you are ready to fit it!
- Clean all receiving parts properly. Make sure your hands and working environment are clean!
- **Never touch the sliding surfaces with ones fingers!**

➤ Take care not to damage the seal during assembly. Never put the rings down on their sliding surfaces! *Special tools: Mounting the mechanical seal unit is easier when you use a special tapered mounting bush. That way, the sharp shaft edges are covered so that the risk of damaging the seal during assembly is reduced. See figure 9.*

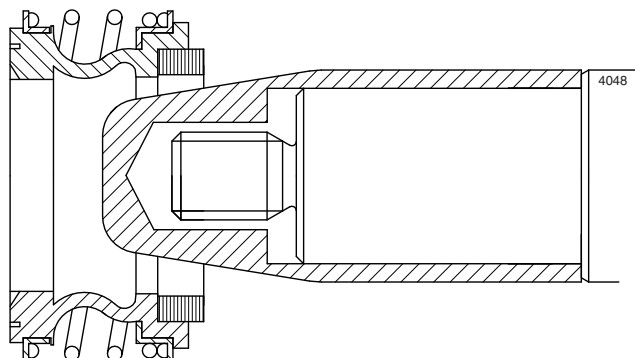

Figure 9: Special mounting bush.

7.7.2 Disassembling a mechanical seal M0

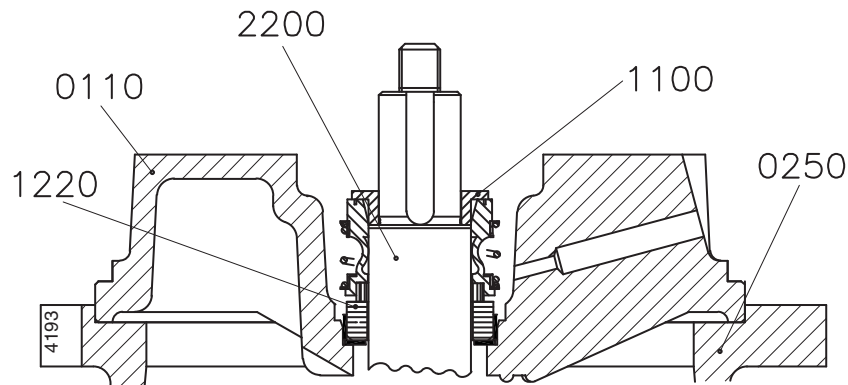

Figure 10: Mechanical seal M0.

The item numbers used are referring to figure 10.

- 1 Remove the impeller, see paragraph 7.5.1 "Disassembling of the impeller".
- 2 Pull the distance sleeve (1100) and the rotating part of the mechanical seal (1220) off the shaft.
- 3 Mark the position of the pump cover (0110) in relation to the lantern piece (0250). Knock the pump cover loose and remove it.
- 4 Push the counter-ring of the mechanical seal (1220) out of the pump cover.

7.7.3 Assembling a mechanical seal M0

- 1 Make sure the stub shaft (2200) is not damaged. If it is, replace it.
- 2 Place the electric motor with the shaft upright.
- 3 Put the pump cover flat down and press the counter-ring of the seal straight into it. If necessary, use a plastic pressure piece. **Never hammer it inside!** The maximum axial turn of the counter-ring is 0,1 mm.
- 4 Mount the pump cover in the right position in the collar of the lantern piece. Check whether the pump cover is at right angles to the stub shaft.
- 5 Push the rotating part of the mechanical seal on the distance sleeve (1100). **Put some glycerine or silicon spray on the bellows to facilitate the assembly!**
- 6 Mount the impeller, see paragraph 7.5.2 "Mounting the impeller".

7.7.4 Disassembling a mechanical seal M1

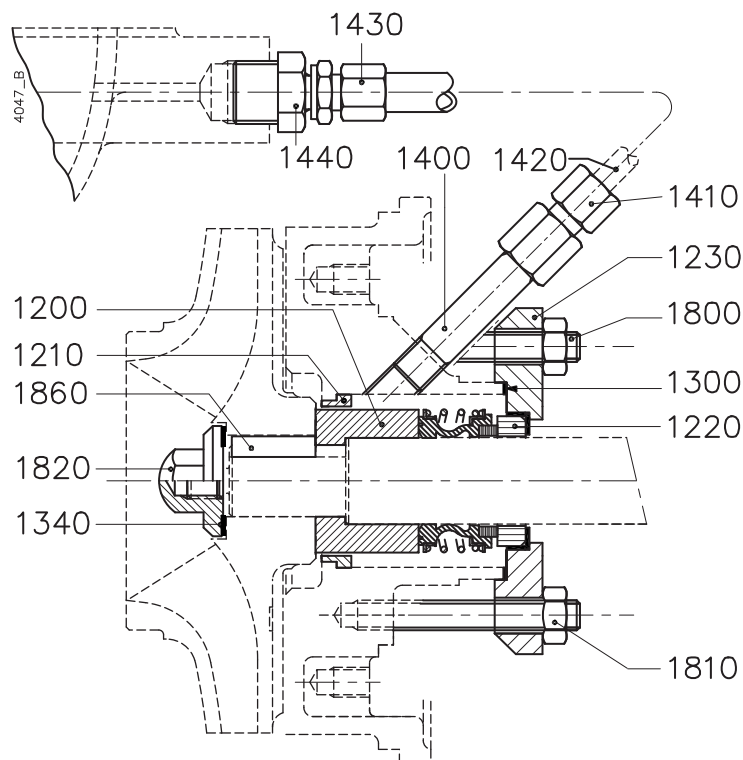

Figure 11: Mechanical seal M1.

The item numbers used are referring to figure 11.

- 1 Remove the impeller, see paragraph 7.5.1 "Disassembling of the impeller".
- 2 Remove the nuts (1810) and push the mechanical seal cover (1230) backward.
- 3 Mark the position of the stuffing box cover (0110) in relation to the bearing bracket (2100). Knock the stuffing box cover loose and remove it.
- 4 Pull the shaft sleeve (1200) from the pump shaft and remove the rotating part of the mechanical seal from the shaft sleeve.
- 5 Pull the mechanical seal cover (1230) off the pump shaft and push the counter-ring out of the cover.

7.7.5 Assembling a mechanical seal M1

➤ *Special tools: the seal group M1 is easily mounted by using a special conical mounting bush. The mounting bush covers the sharp edges on the shaft, which means that the risk of damaging the seal during assembly is reduced. See figure 9.*

- 1 Ensure the shaft sleeve (1200), the throttling bush (1210) and the splash ring (2220) are undamaged. The splash ring should also clasp the pump shaft properly. If necessary, replace these parts. In that case, secure the throttling bush (1210) with Loctite 641.
- 2 Put the mechanical seal cover flat down and press the counter-ring of the seal straight into it. If necessary, use a plastic pressure piece. **Never hammer it inside!** The maximum axial turn of the counter-ring is 0,1 mm.
- 3 Place the electric motor with the shaft and the lantern piece upright and place a new gasket (1300).
- 4 Push the mechanical seal cover onto the pump shaft.

- 5 Push the rotating part of the seal onto the pump shaft. The bellows should slide smoothly over the shaft. Put some glycerine or silicon spray on it.
- 6 Fit the stuffing box cover in the right position in the fitting edge of the bearing bracket. **Check whether the stuffing box cover is at right angles to the pump shaft.**
- 7 Fit the mechanical seal cover (1230) to the stuffing box cover. Check the position in view of the connection points. Tighten the nuts (1810) crosswise. The cover should not be placed oblique.
- 8 Mount the shaft sleeve (1200).
- 9 Fit the impeller and other parts, see paragraph 7.5.2 "Mounting the impeller"

7.7.6 Disassembling a mechanical seal M2-M3

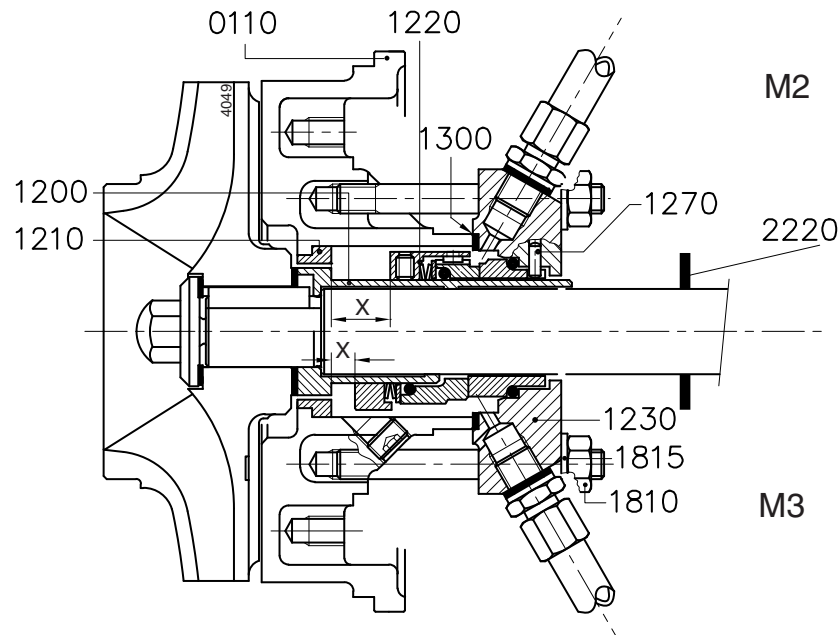

Figure 12: Mechanical seal M2-M3.

The item numbers used are referring to figure 12.

- 1 Remove the impeller, see paragraph 7.5.1 "Disassembling of the impeller"
- 2 Remove the nuts (1810) and the washers (1815) and push the mechanical seal cover (1230) backward.
- 3 Mark the position of the stuffing box cover (0110) in relation to the bearing bracket (2100). Knock the stuffing box cover loose and remove it.
- 4 Pull the shaft sleeve (1200) off the pump shaft. Loosen the set screw (n.a. for bellows seal) and remove the rotating part of the mechanical seal from the shaft sleeve.
- 5 Pull the mechanical seal cover (1230) off the pump shaft. Push the counter-ring of the mechanical seal through the shaft passage inward out of the cover

7.7.7 Assembling a mechanical seal M2-M3

- 1 Ensure the shaft sleeve (1200), the throttling bush (1210) and the splash ring (2220) are undamaged. The splash ring should also clasp the pump shaft properly. If necessary, replace these parts. In that case, secure the throttling bush (1210) with Loctite 641.
- 2 Put the mechanical seal cover flat down and press the counter-ring of the seal straight into it. The notch in the counter ring must correspond to the locking pin (1270), else the counter ring will break! If necessary, use a plastic pressure piece. **Never hammer it inside!** The maximum axial turn of the counter-ring is 0,1 mm.
- 3 Place the bearing bracket with the shaft upright and place a new gasket (1300).
- 4 Push the mechanical seal cover onto the pump shaft.
- 5 Push the rotating part of the seal onto the shaft sleeve. Put some glycerine or silicon spray on the O-ring or the bellows to facilitate the assembly.
- 6 Fix the rotating part of the seal on the shaft sleeve according to dimension X in Table 4. See figure 12.

Table 4: Value X for adjusting mechanical seals M2-M3.

M2		M3	
diameter shaft sleeve	X	diameter pump shaft	X
35	22,5	30	15
45	30	40	22,5
55	37,5	50	27,5

- 7 Push the shaft sleeve (1200) onto the pump shaft.
- 8 Fit the stuffing box cover in the right position in the fitting edge of the bearing bracket. **Check whether the stuffing box cover is at right angles to the pump shaft.**
- 9 Fit the mechanical seal cover (1230) to the stuffing box cover. Check the position in view of the connection points. Tighten the nuts (1810) crosswise. The cover should not be placed oblique.
- 10 Fit the impeller and other parts, see paragraph 7.5.2 "Mounting the impeller"

7.7.8 Removing the electric motor

- 1 Disassemble the impeller and the shaft sleeve, see paragraph 7.5.1 "Disassembling of the impeller" and paragraph 7.6.4 "Disassembling the shaft sleeve".
- 2 Remove bolts (0850) and lift the electric motor at the lifting eyes off the lantern piece, using a pulley.



For further disassembly of the electric motor: see the appropriate instructions in the User manual of the electric motor.

7.7.9 Mounting the electric motor

- 1 Lift the electric motor at the lifting eyes onto the lantern piece, using a pulley and mount bolts (0850).
- 2 Mount the shaft sleeve, the stuffing box cover and the impeller, see paragraph 7.6.5 "Mounting the shaft sleeve", paragraph 7.6.3 "Mounting a new stuffing box packing S2, S3, S4" and paragraph 7.5.2 "Mounting the impeller".

7.8 Replacing the stub shaft and the motor for M0

7.8.1 Disassembling the stub shaft and the motor

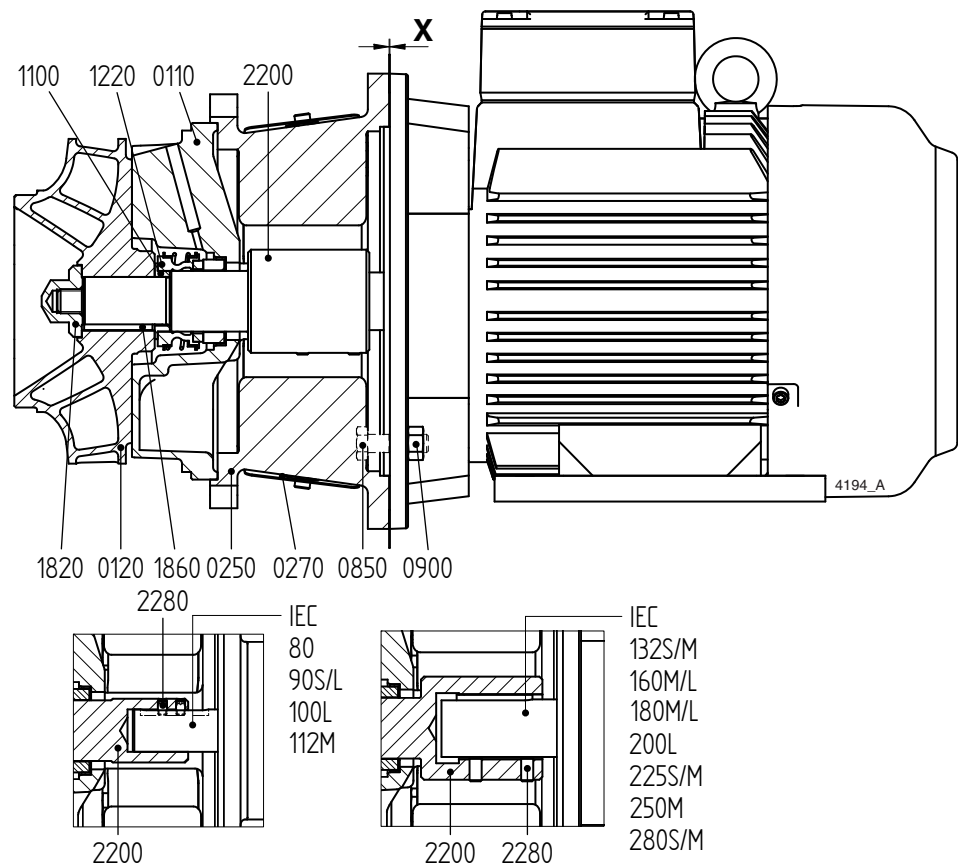

Figure 13: Assembly of the stub shaft

The item numbers used are referring to figure 13.

- 1 Dismantle the impeller and the shaft seal. See paragraph 7.5.1 "Disassembling of the impeller" and paragraph 7.7.2 "Disassembling a mechanical seal M0".
- 2 Loosen the bolts (0850) and nuts (0900) and remove the lantern piece (0250) from the motor.
- 3 Remove the guards (0270).
- 4 Loosen the set screws (2280) and pull the stub shaft (2200) from the motor shaft.

7.8.2 Assembling the stub shaft and the motor

- 1 For electric motors with IEC-size 80 upto and including 112M: Remove the key from the motor shaft.
- 2 Put the motor in vertical position, shaft end up. Fit the stub shaft (2200) on the motor shaft. **Do not fix the stub shaft yet!**
- 3 For electric motors with IEC size 80 upto and including 112M: make sure the set screws (2280) are positioned over the key way in the motor shaft.
- 4 Place shims between the lantern piece and the motor flange and fit the lantern piece (0250) to the electric motor. See Table 5 for the proper thickness X of the shims

Table 5: Shim thickness X for adjusting the stub shaft

Pump type	Shim thickness X
all types	0,5 mm

- 5 Mount the pump cover (0110), the mechanical seal (1200) and the impeller (0120).
- 6 Push the impeller on the stub shaft until the back blades touch the pump cover.
- 7 Fix the stub shaft on the motor shaft with the set screws (2280).
- 8 Slightly loosen the fastening bolts (0850) of the electric motor and remove the shims.
- 9 Tighten the fastening bolts (0850) of the electric motor crossways with the prescribed tightening moment, see paragraph 10.4.1 "Tightening moments for bolts and nuts".
- 10 Place the gasket (0300) and fit the pump casing (0100). Fix the pump casing with nuts (0810). Tighten them crossways. see paragraph 10.4.1 "Tightening moments for bolts and nuts".
- 11 Fit the guards (0270).

8 Dimensions

8.1 Dimensions delivery flange

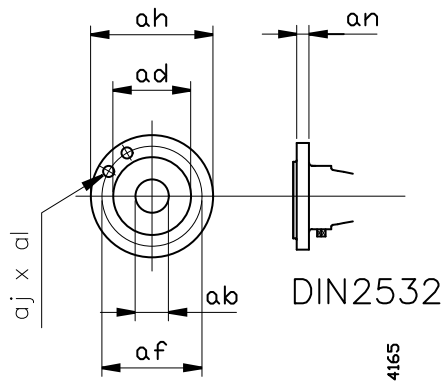

Figure 14: Dimensions delivery flange.

DIN 2532					
ab	ad	af	ah	aj x al	an
32	78	100	140	4 x 18	18
40	88	110	150	4 x 18	18
50	102	125	165	4 x 18	20
65	122	145	185	4 x 18	20
80	138	160	200	8 x 18	22
100	158	180	220	8 x 18	22
125	188	210	250	8 x 18	24
150	212	240	285	8 x 23	24
200	268	295	340	8 x 23	26
250	320	350	395	12 x 23	28

8.2 Dimensions suction flange

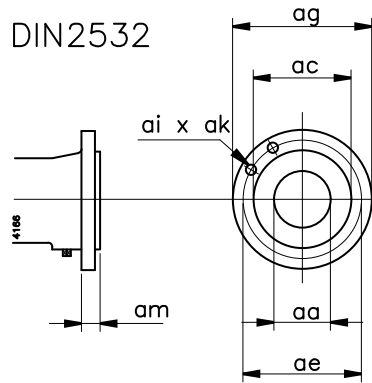

Figure 15: Dimensions suction flange.

aa	ac	ae	ag	ai x ak	am
65	122	145	185	4 x 18	24
80	138	160	200	8 x 18	35
100	158	180	220	8 x 18	37
125	188	210	250	8 x 18	28
150	212	240	285	8 x 22	29
200	268	295	340	8 x 22	31

8.3 Dimensions foot pads K1

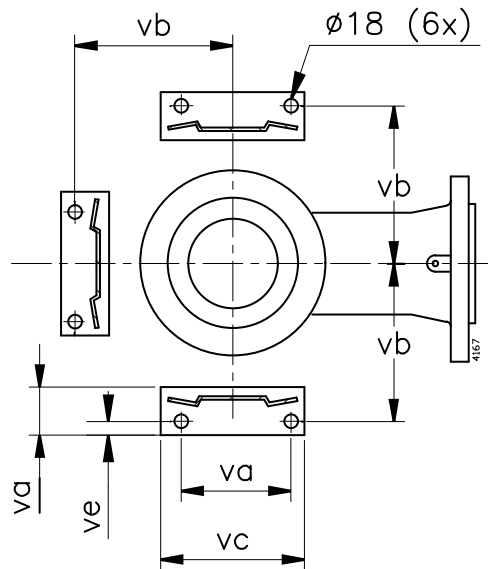

Figure 16: Dimensions foot pads (Top view).

	va	vb	vc	vd	ve
...-160	120	180	160	80	19
...-200	130	205	180	80	17
...-250	155	230	205	80	20
...-315	175	255	220	80	18
...-400	220	310	270	80	18
200-200: ...-250					

8.4 Pump dimensions K1, with suction bend

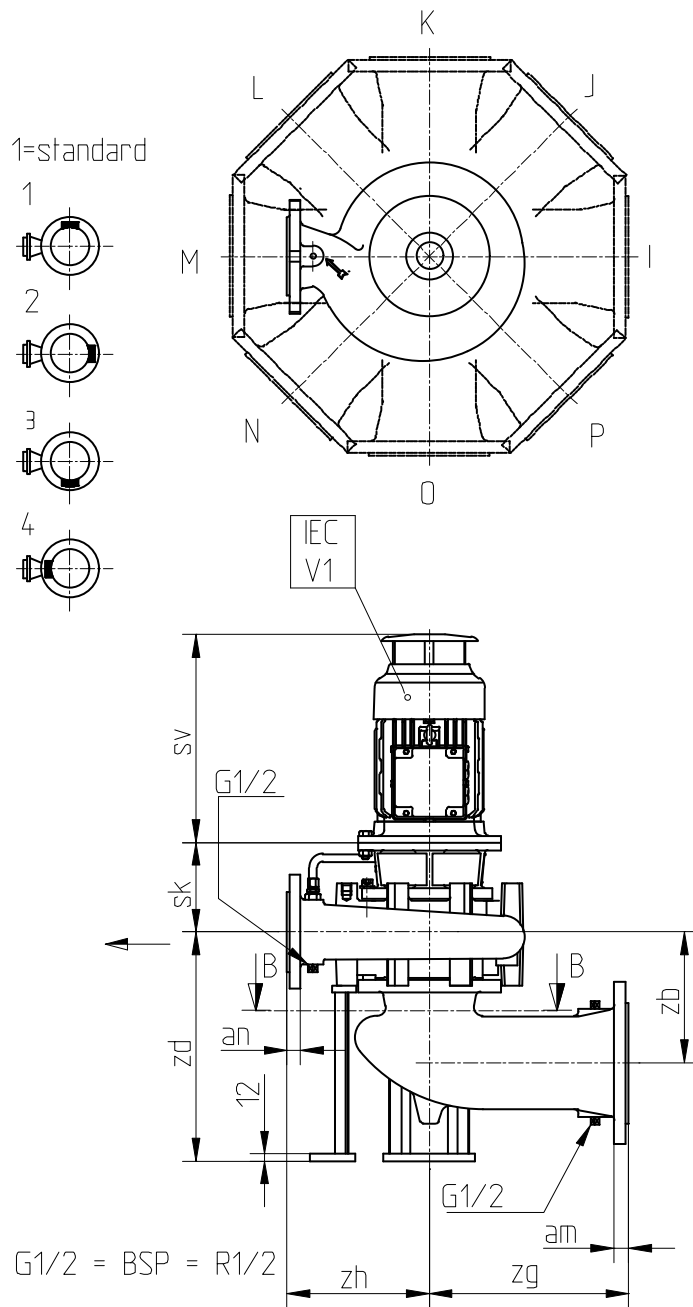

Figure 17: Pump dimensions K1, with suction bend.

Standard:

- suction bend: pos I
- junction box electric motor: pos 1

8.4.1 Pump dimensions M0

	aa	ab	zb	zd	zg	zh	sk						
							80 90S/L	100L 112M	132S/M	160M/L 180M/L	200L	225S/M	250M 280S/M
32-160	65	32	167	330	220	250	145,5	155,5	175,5				
32-200	80	32	177	350	220	280	145,5	155,5	175,5	205,5	205,5		
40-160	80	40	177	330	220	250	145,5	155,5	175,5	205,5	205,5		
40-200	80	40	192	350	220	280	145,5	155,5	175,5	205,5	205,5		
40-250	100	40	202	370	250	315	145,5	155,5	175,5	205,5	225,5		
50-160	80	50	192	345	220	250	145,5	155,5	175,5	205,5	225,5		
50-200	100	50	202	350	250	280	145,5	155,5	175,5	205,5	205,5		
50-250	100	50	202	370	250	315	145,5	155,5	175,5	205,5	225,5		
65-160	125	65	242	375	240	250	145,5	155,5	175,5	205,5	205,5		
65-200	125	65	222	375	240	280	145,5	155,5	175,5	205,5	205,5		
65A-250	125	65	242	370	240	315	160	170	190	220	240	250	270
80-160	150	80	232	390	350	250	145,5	155,5	175,5	205,5	205,5		
80-200	150	80	252	400	350	280	161	171	191	221	221	251	251
80-250	150	80	252	400	350	315	160	170	190	220	240	250	270
100C-200	150	100	252	415	350	280	161	171	191	221	221	251	251
100-250	150	100	252	420	350	315	160	170	190	220	240	250	270
125-250	150	125	267	440	280	355	160	170	190	220	240		
125-315	150	125	277	495	280	355			211,5	241,5	241,5	283,5	283,5
150-315	200	150	342	520	350	400			211,5	241,5	241,5	283,5	283,5
200-200	150	200	337	485	280	400			190	220	240	250	270
250B-315	200	250	337	550	350	500				241,5	241,5	283,5	283,5

IEC motor	80	90S	90L	100 L	112 M	132 S	132 M	160 M	160 L	180 M	180 L	200 L	225 S	225 M	250 M	280 S	280 M
sv ^(*)	286	308	332	366	392	450	488	548	592	626	662	754	768	792	1000	1160	

(*) motor length based on DIN 42677, could be different due to applied motor make

8.4.2 Pump dimensions S2/S3/S4/M1/M2/M3

	aa	ab	zb	zd	zg	zh	sk						
							80 90S/L	100L 112M	132S/M	160M/L 180M/L	200L	225S/M	250M 280S/M
32-160	65	32	167	330	220	250	145,5	155,5	175,5				
32-200	80	32	177	350	220	280	145,5	155,5	175,5	205,5	205,5		
40-160	80	40	177	330	220	250	145,5	155,5	175,5	205,5	205,5		
40-200	80	40	192	350	220	280	145,5	155,5	175,5	205,5	205,5		
40-250	100	40	202	370	250	315	145,5	155,5	175,5	205,5	225,5		
50-160	80	50	192	345	220	250	145,5	155,5	175,5	205,5	205,5		
50-200	100	50	202	350	250	280	145,5	155,5	175,5	205,5	205,5		
50-250	100	50	202	370	250	315	145,5	155,5	175,5	205,5	225,5		
65-160	125	65	242	375	240	250	145,5	155,5	175,5	205,5	205,5		
65-200	125	65	222	375	240	280	145,5	155,5	175,5	205,5	205,5		
65A-250	125	65	242	370	240	315	148,5	158,5	178,5	208,5	228,5	238,5	258,5
65-315	125	65	242	455	240	315	178,5	188,5	208,5	238,5			
80-160	150	80	232	390	350	250	145,5	155,5	175,5	205,5	205,5		
80-200	150	80	252	400	350	280	158,5	168,5	188,5	218,5	218,5	248,5	248,5
80-250	150	80	252	400	350	315	148,5	158,5	178,5	208,5	228,5	238,5	258,5
80-315	150	80	252	455	350	315	178,5	188,5	208,5	238,5	238,5		
80(A)-400	150	80	252	425	350	405			211,5	241,5	241,5	283,5	283,5
100C-200	150	100	252	415	350	280	158,5	168,5	188,5	218,5	218,5	248,5	248,5
100-250	150	100	252	420	350	315	148,5	158,5	178,5	208,5	228,5	238,5	258,5
100-315	150	100	252	475	350	315	178,5	188,5	208,5	238,5	238,5		
100-400	150	100	252	425	350	375			211,5	241,5	241,5	283,5	283,5
125-250	150	125	267	440	280	355	148,5	158,5	178,5	208,5	228,5		
125-315	150	125	277	495	280	355			211,5	241,5	241,5	283,5	283,5
125-400	150	125	277	425	280	400			211,5	241,5	241,5	283,5	283,5
150-315	200	150	342	520	350	400			211,5	241,5	241,5	283,5	283,5
150-400	200	150	342	520	350	450				241,5	241,5	283,5	283,5
200-200	150	200	337	485	280	400			178,5	208,5	228,5	238,5	258,5
250B-315	200	250	337	550	350	500				241,5	241,5	283,5	283,5

IEC motor	80	90S	90L	100 L	112 M	132 S	132 M	160 M	160 L	180 M	180 L	200 L	225 S	225 M	250 M	280 S	280 M
sv ^(*)	286	308	332	366	392	450	488	548	592	626	662	754	768	792	1000	1160	

(*) motor length based on DIN 42677, could be different due to applied motor make

8.5 Pump dimensions K3, with suction bend

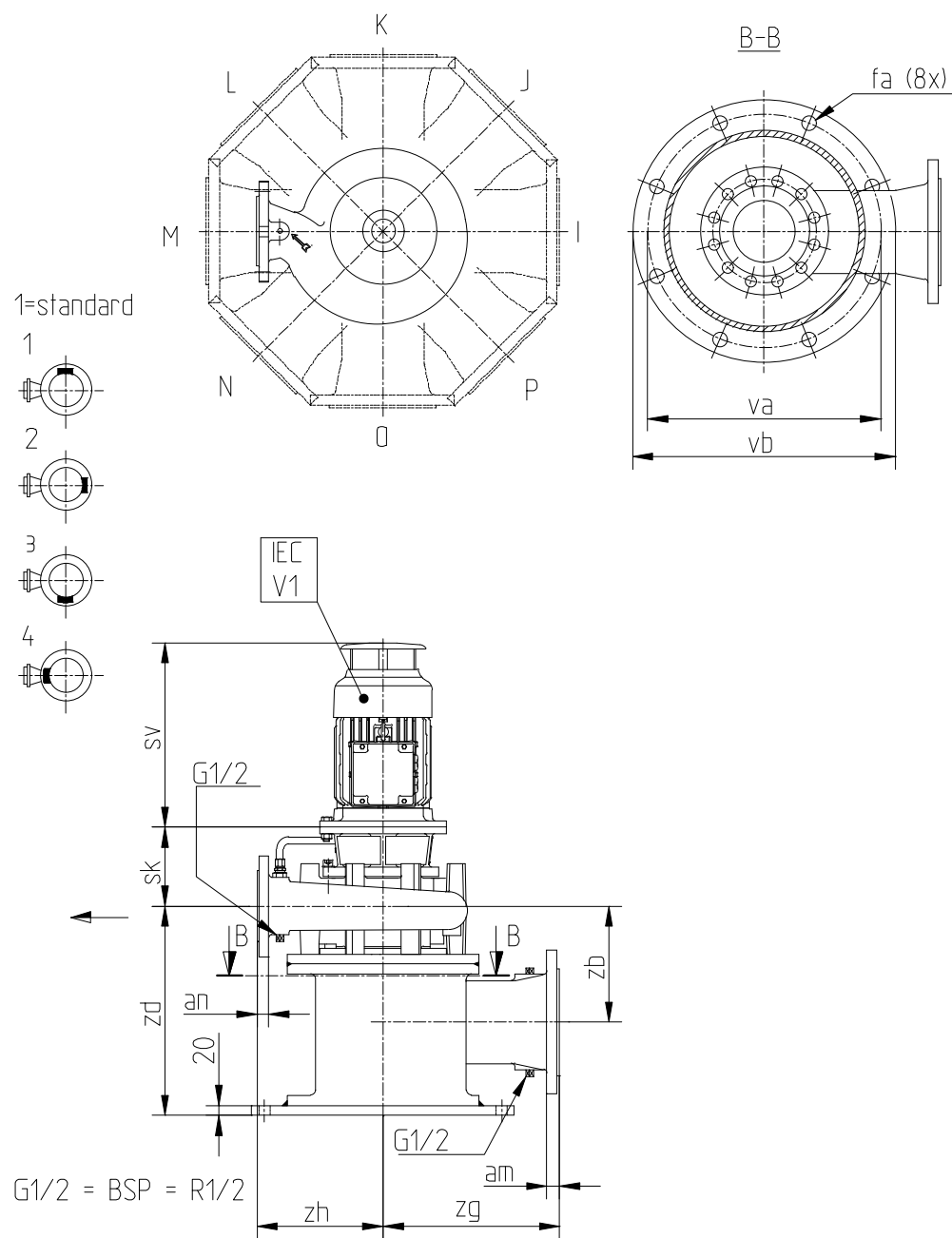

Figure 18: Pump dimensions K3, with suction bend.

Standard:

- suction bend: pos 1
- junction box electric motor: pos 1

8.5.1 Pump dimensions M0

	aa	ab	zb	zd	zg	zh	sk						
							80 90S/L	100L 112M	132S/M	160M/L 180M/L	200L	225S/M	250M 280S/M
32-160	65	32	167	400	220	250	145,5	155,5	175,5				
32-200	80	32	177	400	220	280	145,5	155,5	175,5	205,5	205,5		
40-160	80	40	177	400	220	250	145,5	155,5	175,5	205,5	205,5		
40-200	80	40	192	400	220	280	145,5	155,5	175,5	205,5	205,5		
40-250	100	40	202	400	250	315	145,5	155,5	175,5	205,5	225,5		
50-160	80	50	192	400	220	250	145,5	155,5	175,5	205,5	205,5		
50-200	100	50	202	500	250	280	145,5	155,5	175,5	205,5	205,5		
50-250	100	50	202	500	250	315	145,5	155,5	175,5	205,5	225,5		
65-160	125	65	242	500	240	250	145,5	155,5	175,5	205,5	205,5		
65-200	125	65	222	500	240	280	145,5	155,5	175,5	205,5	205,5		
65A-250	125	65	242	500	240	315	160	170	190	220	240	250	270
80-160	150	80	232	500	350	250	145,5	155,5	175,5	205,5	205,5		
80-200	150	80	252	500	350	280	161	171	191	221	221	251	251
80-250	150	80	252	500	350	315	160	170	190	220	240	250	270
100C-200	150	100	252	500	350	280	161	171	191	221	221	251	251
100-250	150	100	252	500	350	315	160	170	190	220	240	250	270
125-250	150	125	267	500	280	355	160	170	190	220	240		
125-315	150	125	277	500	280	355			211,5	241,5	241,5	283,5	283,5
150-315	200	150	342	600	350	400			211,5	241,5	241,5	283,5	283,5
200-200	150	200	337	600	280	400			190	220	240	250	270
250B-315	200	250	337	600	350	500				241,5	241,5	283,5	283,5

IEC motor	80	90S	90L	100 L	112 M	132 S	132 M	160 M	160 L	180 M	180 L	200 L	225 S	225 M	250 M	280 S	280 M
sv ^(*)	286	308	332	366	392	450	488	548	592	626	662	754	768	792	1000	1160	

(*) motor length based on DIN 42677, could be different due to applied motor make

8.5.2 Pump dimensions S2/S3/S4/M1/M2/M3

	aa	ab	zb	zd	zg	zh	sk						
							80 90S/L	100L 112M	132S/M	160M/L 180M/L	200L	225S/M	250M 280S/M
32-160	65	32	167	400	220	250	145,5	155,5	175,5				
32-200	80	32	177	400	220	280	145,5	155,5	175,5	205,5	205,5		
40-160	80	40	177	400	220	250	145,5	155,5	175,5	205,5	205,5		
40-200	80	40	192	400	220	280	145,5	155,5	175,5	205,5	205,5		
40-250	100	40	202	400	250	315	145,5	155,5	175,5	205,5	225,5		
50-160	80	50	192	400	220	250	145,5	155,5	175,5	205,5	205,5		
50-200	100	50	202	500	250	280	145,5	155,5	175,5	205,5	205,5		
50-250	100	50	202	500	250	315	145,5	155,5	175,5	205,5	225,5		
65-160	125	65	242	500	240	250	145,5	155,5	175,5	205,5	205,5		
65-200	125	65	222	500	240	280	145,5	155,5	175,5	205,5	205,5		
65A-250	125	65	242	500	240	315	148,5	158,5	178,5	208,5	228,5	238,5	258,5
65-315	125	65	242	500	240	315	178,5	188,5	208,5	238,5			
80-160	150	80	232	500	350	250	145,5	155,5	175,5	205,5	205,5		
80-200	150	80	252	500	350	280	158,5	168,5	188,5	218,5	218,5	248,5	248,5
80-250	150	80	252	500	350	315	148,5	158,5	178,5	208,5	228,5	238,5	258,5
80-315	150	80	252	500	350	315	178,5	188,5	208,5	238,5	238,5		
80(A)-400	150	80	252	500	350	405			211,5	241,5	241,5	283,5	283,5
100C-200	150	100	252	500	350	280	158,5	168,5	188,5	218,5	218,5	248,5	248,5
100-250	150	100	252	500	350	315	148,5	158,5	178,5	208,5	228,5	238,5	258,5
100-315	150	100	252	500	350	315	178,5	188,5	208,5	238,5	238,5		
100-400	150	100	252	500	350	375			211,5	241,5	241,5	283,5	283,5
125-250	150	125	267	500	280	355	148,5	158,5	178,5	208,5	228,5		
125-315	150	125	277	500	280	355			211,5	241,5	241,5	283,5	283,5
125-400	150	125	277	500	280	400			211,5	241,5	241,5	283,5	283,5
150-315	200	150	342	600	350	400			211,5	241,5	241,5	283,5	283,5
150-400	200	150	342	600	350	450				241,5	241,5	283,5	283,5
200-200	150	200	337	600	280	400			178,5	208,5	228,5	238,5	258,5
250B-315	200	250	337	600	350	500				241,5	241,5	283,5	283,5

IEC motor	80	90S	90L	100 L	112 M	132 S	132 M	160 M	160 L	180 M	180 L	200 L	225 S	225 M	250 M	280 S	280 M
sv ^(*)	286	308	332	366	392	450	488	548	592	626	662	754	768	792	1000	1160	

(*) motor length based on DIN 42677, could be different due to applied motor make

9 Parts

9.1 Ordering parts

9.1.1 Order form

You can use the order form included in this manual for ordering parts.

When ordering parts always quote the following data:

- 1 Your **address**.
- 2 The **quantity, the item number and the description** of the part.
- 3 The **pump number**. The pump number is stated on the label on the cover of this manual and on the type plate of the pump.
- 4 In the event of different electric motor voltage you should state the correct voltage.

9.1.2 Recommended spare parts

Parts marked with a * are recommended spare parts.

9.2 Pump construction K1

9.2.1 Sectional drawing M0

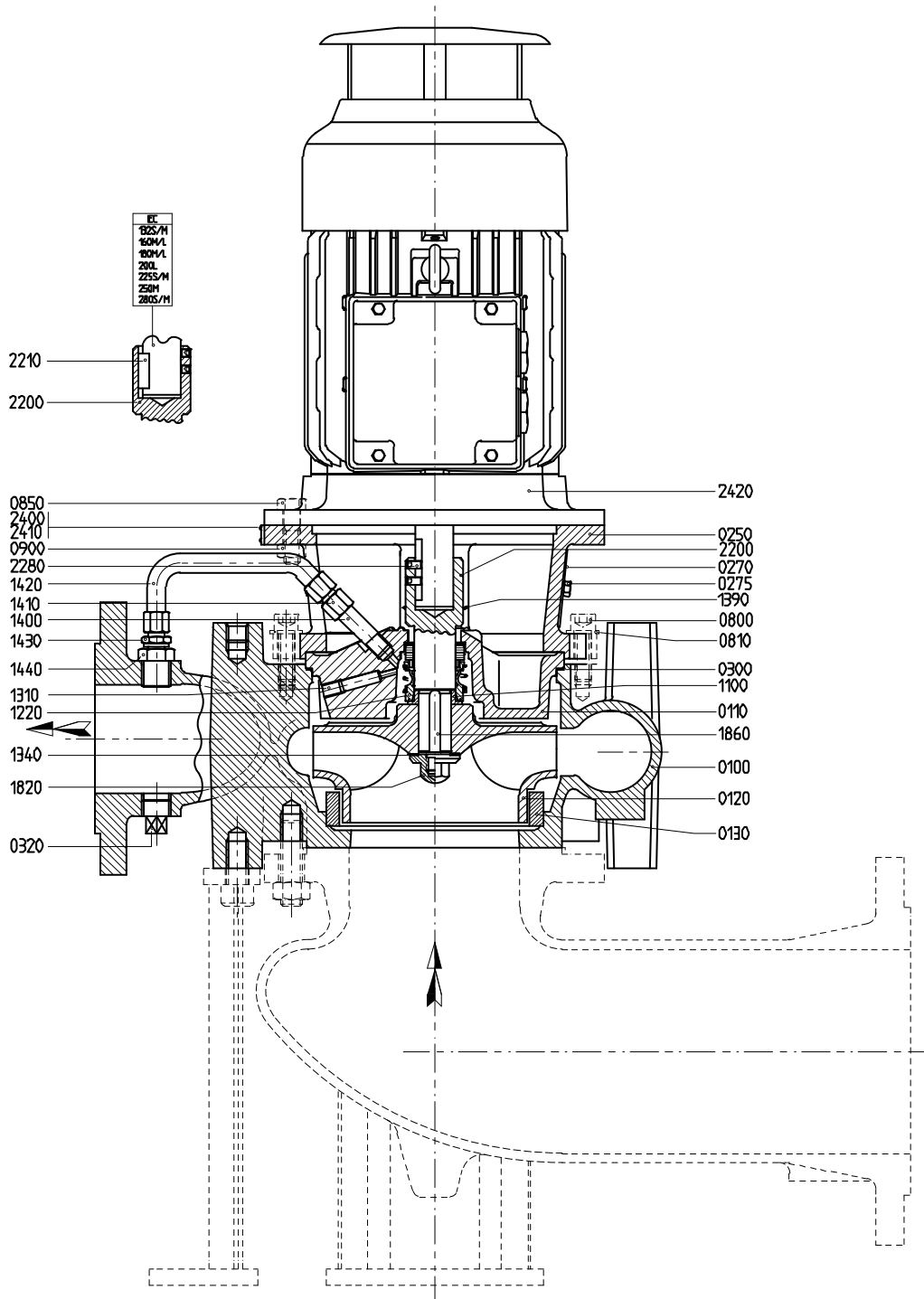

Figure 19: Sectional drawing M0.

9.2.2 Parts list M0

Item	Quantity	Description	Material				
			G1	G2	G3	B2	B3
0100	1	pump casing	cast iron			bronze	
0110	1	pump cover	cast iron			bronze	
0120*	1	impeller	cast iron	bronze	alu.brz	bronze	alu.brz
0130*	1	wear ring	cast iron	bronze			
0250	1	lantern piece	cast iron				
0270	2	guard	aluminium				
0275	4	bolt	steel				
0300*	1	gasket	--				
0320	1	plug	malleable cast iron			bronze	
0800	4/8/12 ^(*)	Allen screw	steel				
0810	(**)	washer	steel				
0850	4	bolt	steel				
0900	4	nut	steel				
1100	1	distance sleeve	stainless steel				
1220*	1	mechanical seal	--				
1310*	1	plug	malleable cast iron			bronze	
1340*	1	gasket	--				
1390	1	O-ring	rubber				
1400	1	pipe nipple	steel			stainless steel	
1410	1	pipe joint	brass				
1420	1	pipe	copper			stainless steel	
1430	1	male connector	brass				
1440	1	reducer	steel			brass	
1820*	1	cap nut	stainless steel				
1860*	1	impeller key	stainless steel				
2200*	1	stub shaft	stainless steel				
2210	1	key	steel				
2280*	2	set screw	stainless steel				
2400	1	type plate	stainless steel				
2410	1	arrow plate	aluminium				
2420	1	elektric motor	(IEC - IM 3001)				

alu.brz = aluminium bronze

(*) Quantity depends on pump type

(**) Only for 200-200

9.2.3 Sectional drawing M1/M2/M3/S2/S3/S4

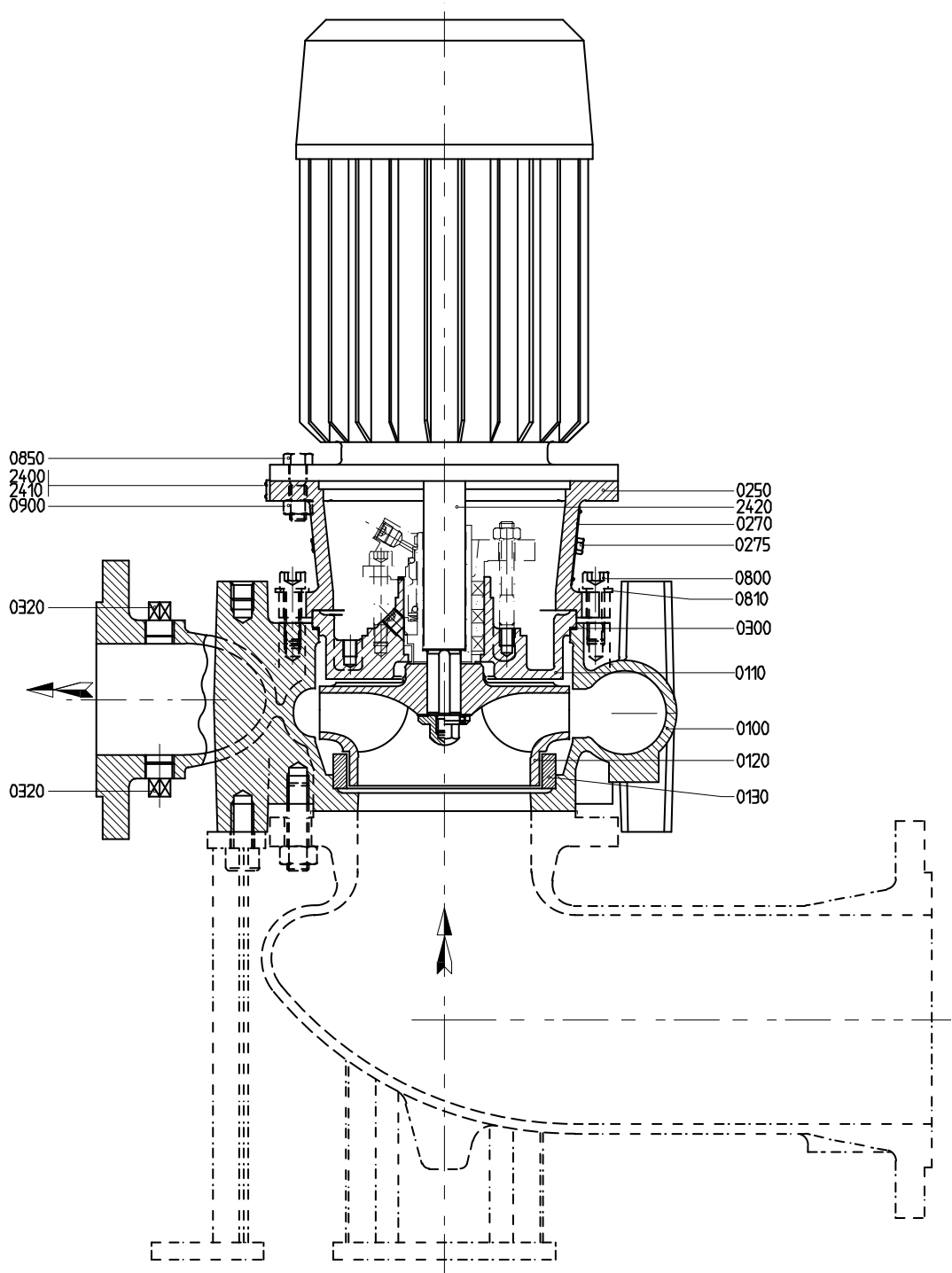

Figure 20: Sectional drawing M1/M2/M3/S2/S3/S4.

9.2.4 Parts list M1/M2/M3/S2/S3/S4

Item	Quantity	Description	Material				
			G1	G2	G3	B2	B3
0100	1	pump casing	cast iron			bronze	
0110	1	stuffing box cover	cast iron			bronze	
0120*	1	impeller	cast iron	bronze	alu.brz	bronze	alu.brz
0130*	1	wear ring	cast iron	bronze			
0250	1	lantern piece	cast iron				
0270	2	protective cover	aluminium				
0275	4	bolt	steel				
0300*	1	gasket	--				
0320	2	plug	malleable cast iron			bronze	
0800	4/8/12 ^(*)	Allen screw	steel				
0810	^(**)	washer	steel				
0850	4	bolt	steel				
0900	4	nut	steel				
1220*	1	shaft sealing	see separate parts lists				
2400	1	type plate	stainless steel				
2410	1	arrow plate	aluminium				
2420	1	electric motor with extended shaft	(IEC - IM 3001)				

alu.brz = aluminium bronze

(*) Quantity depends on pump type

(**) Only for 200-200

9.3 Pump construction K3

9.3.1 Sectional drawing M1/M2/M3/S2/S3/S4

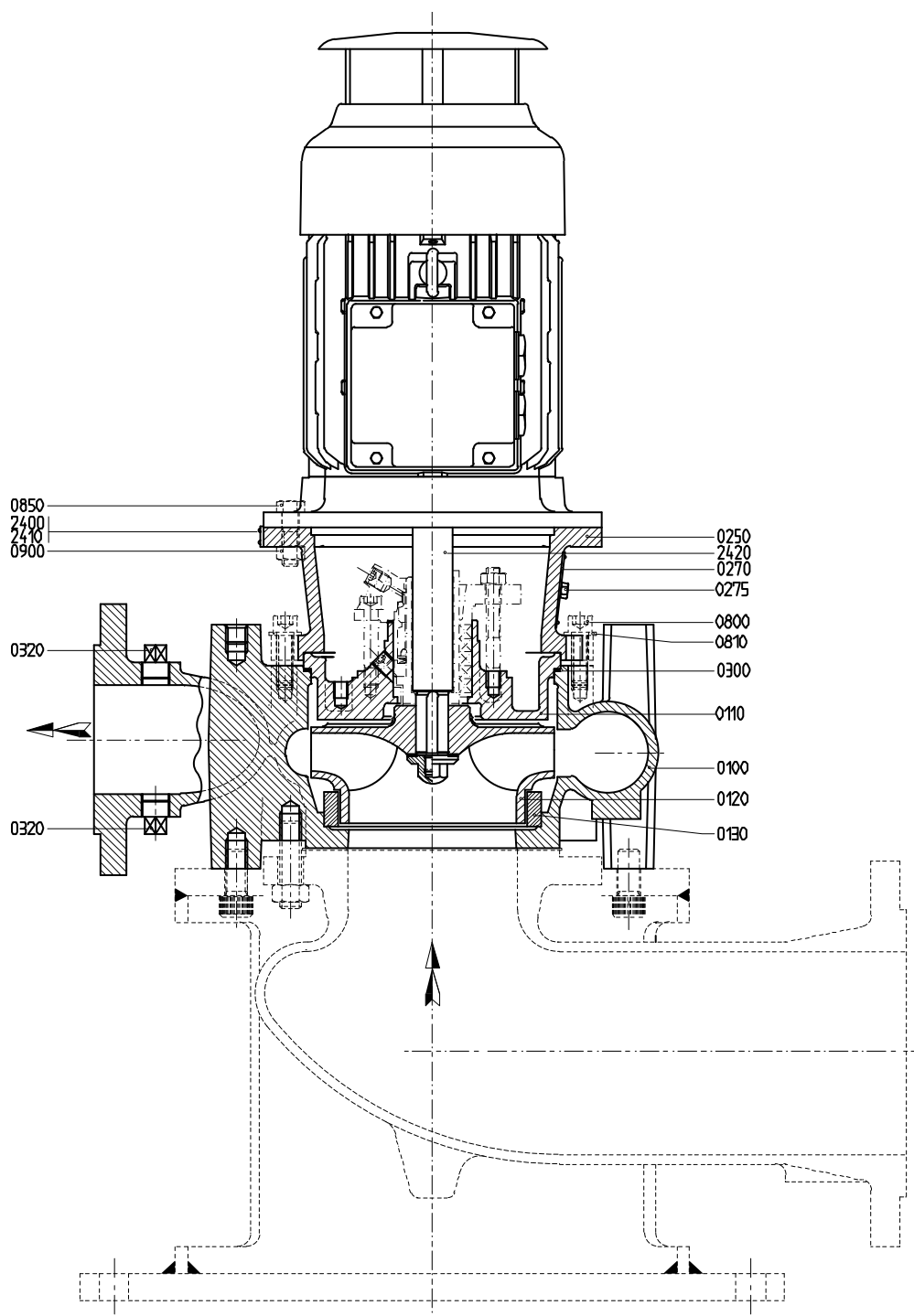

Figure 21: Sectional drawing M1/M2/M3/S2/S3/S4.

9.3.2 Parts list M1/M2/M3/S2/S3/S4

Item	Quantity	Description	Material				
			G1	G2	G3	B2	B3
0100	1	pump casing	cast iron			bronze	
0110	1	stuffing box cover	cast iron			bronze	
0120*	1	impeller	cast iron	bronze	alu.brz	bronze	alu.brz
0130*	1	wear ring	cast iron	bronze			
0250	1	lantern piece	cast iron				
0270	2	protective cover	aluminium				
0275	4	bolt	steel				
0300*	1	gasket	--				
0320	2	plug	malleable cast iron			bronze	
0800	4/8/12 ^(*)	Allen screw	steel				
0810	^(**)	washer	steel				
0850	4	bolt	steel				
0900	4	nut	steel				
1220*	1	shaft sealing	see separate parts lists				
2400	1	type plate	stainless steel				
2410	1	arrow plate	aluminium				
2420	1	electric motor with extended shaft	(IEC - IM 3001)				

alu.brz = aluminium bronze

(*) Quantity depends on pump type

(**) Only for 200-200

9.4 Stuffing box packing S2-S3

9.4.1 Stuffing box packing S2-S3

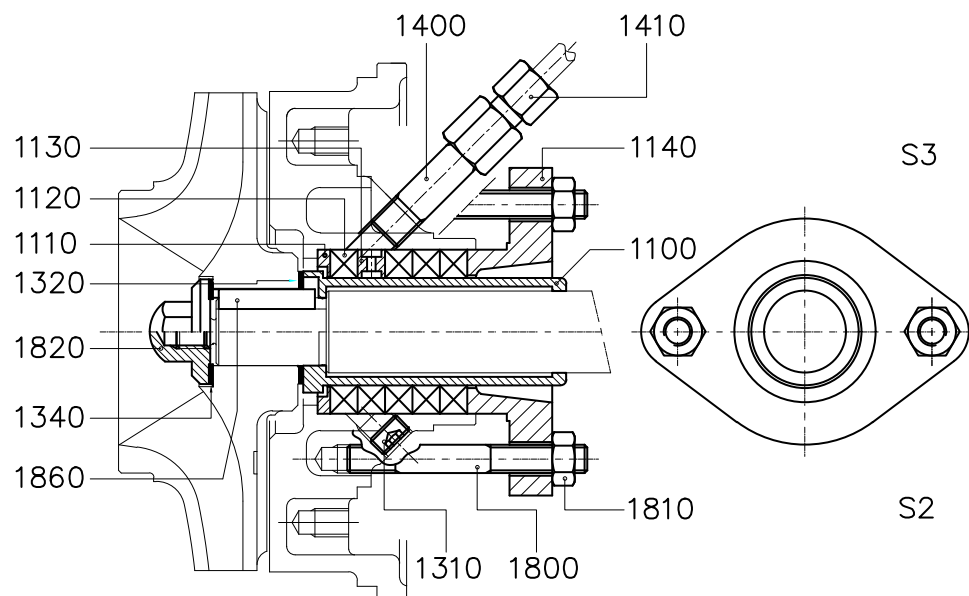

Figure 22: Stuffing box packing S2-S3.

9.4.2 Parts list stuffing box packing S2-S3

Item	Quantity		Description	Material	
	S2	S3		cast iron	bronze
1100*	1	1	shaft sleeve	stainless steel	
1110*	1	1	bottom ring	bronze	
1120*	5	4	packing ring	-	
1130*	-	1	lantern ring	bronze	
1140	1	1	gland	cast iron	bronze
1310	1	-	plug	steel	stainless steel
1320*	1	1	gasket	-	
1340*	1	1	gasket	-	
1400	-	1	pipe nipple	steel	stainless steel
1410	-	1	pipe union	brass	
1800	2	2	stud	stainless steel	
1810	2	2	nut	brass	stainless steel
1820*	1	1	cap nut	bronze	
1860*	1	1	impeller key	stainless steel	

9.5 **Stuffing box packing S4**

9.5.1 Stuffing box packing S4

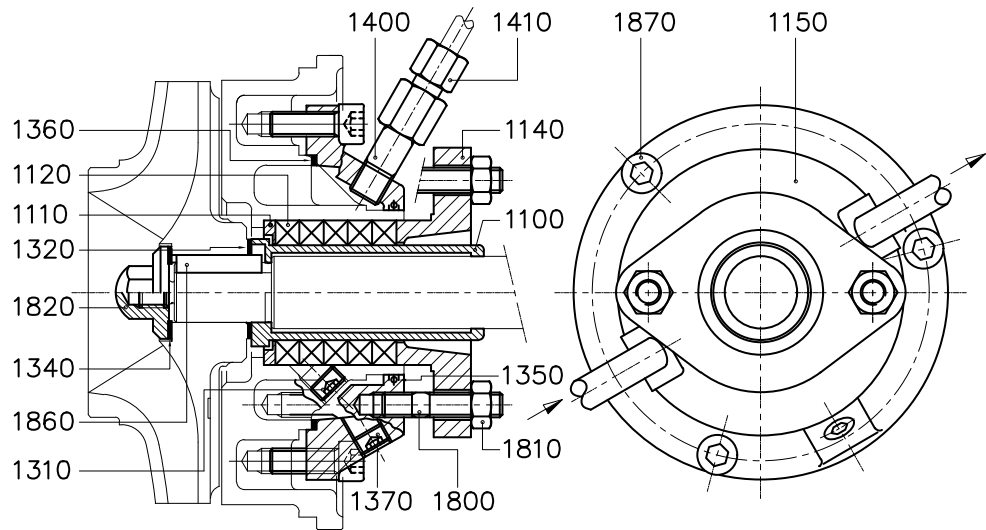

Figure 23: Stuffing box packing S4.

9.5.2 Parts list stuffing box packing S4

Item	Quantity	Description	Material
1100*	1	shaft sleeve	stainless steel
1110*	1	bottom ring	bronze
1120*	5	packing ring	-
1140	1	gland	cast iron
1150	1	cooling jacket	cast iron
1310	1	plug	steel
1320*	1	gasket	-
1340*	1	gasket	-
1350*	1	O-ring	-
1360*	1	gasket	-
1370	1	plug	steel
1400	2	pipe nipple	steel
1410	2	pipe union	brass
1800	2	stud	stainless steel
1810	2	nut	brass
1820*	1	cap nut	bronze
1860*	1	impeller key	stainless steel
1870	3	Allen screw	steel

9.6 Shaft sealing group M1

9.6.1 Mechanical seal MG12-G60

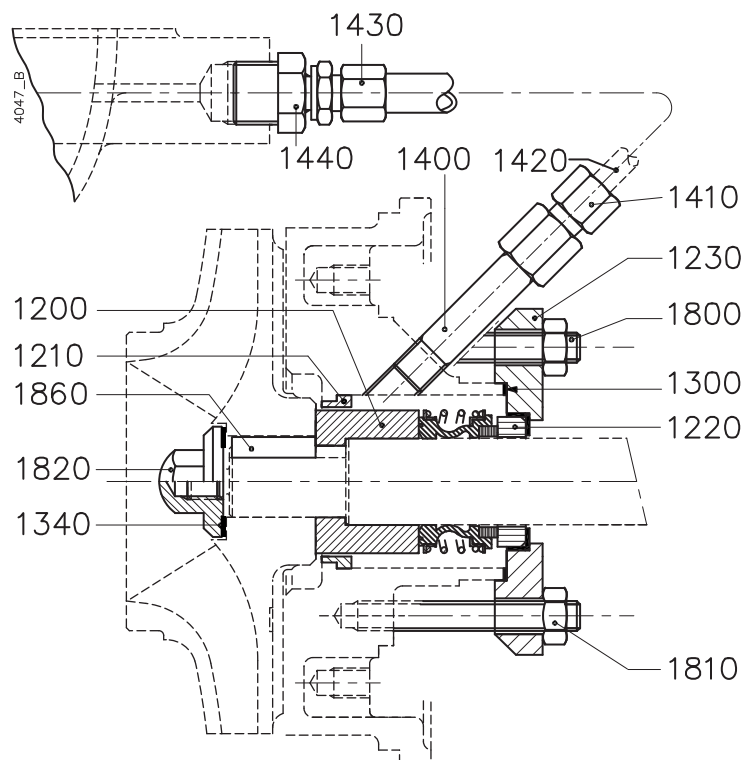

Figure 24: Mechanical seal MG12-G60.

9.6.2 Parts list mechanical seal MG12-G60

Item	Quantity	Description	Material
1200*	1	shaft sleeve	brass
1210*	1	throttling bush	bronze
1220*	1	mechanical seal	-
1230	1	mechanical seal cover	cast iron
1300*	1	gasket	-
1340*	1	gasket	-
1400	1	pipe nipple	steel
1410	1	pipe union	brass
1420	1	pipe	copper
1430	1	pipe union	brass
1440	1	extension piece	stainless steel
1800	2	stud	stainless steel
1810	2	nut	brass
1820*	1	cap nut	stainless steel
1860*	1	impeller key	stainless steel

9.7 Shaft sealing group M2-M3

9.7.1 Mechanical seal M7N-H7N

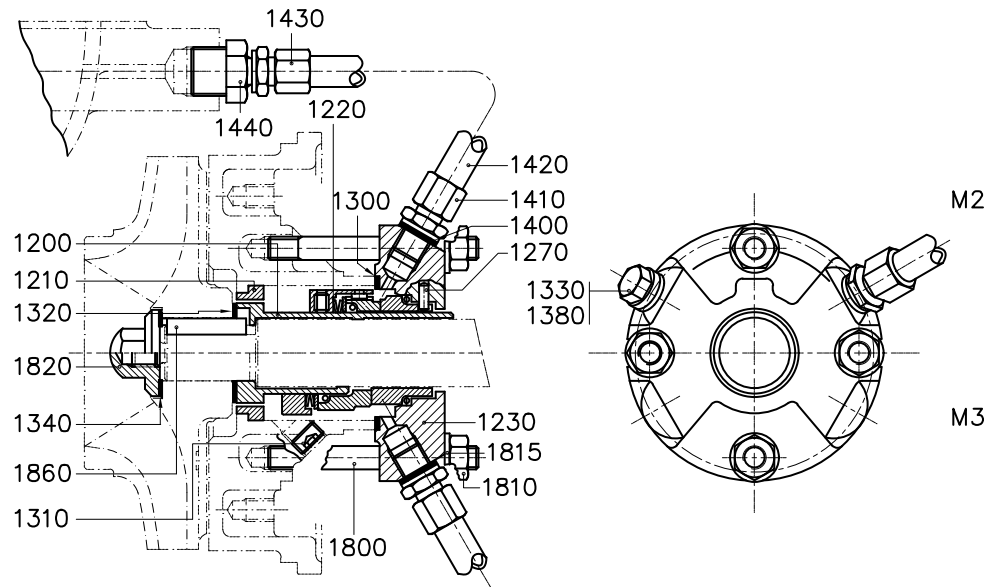

Figure 25: Mechanical seal M7N-H7N.

9.7.2 Parts list mechanical seal M7N-H7N

Item	Quantity		Description	Material	
	M2	M3		cast iron	bronze
1200*	1	1	shaft sleeve	bronze	
1210*	1	1	throttling bush	bronze	
1220*	1	1	mechanical seal	-	
1230	1	1	mechanical seal cover	cast iron	bronze
1270	1	1	locking pin	stainless steel	
1300*	1	1	gasket	-	
1310	1	1	plug	steel	stainless steel
1320*	1	1	gasket	-	
1330	1	1	plug	steel	stainless steel
1340*	1	1	gasket	-	
1380	1	1	sealing ring	copper	
1400	1	1	sealing ring	copper	
1410	1	1	male connector	brass	
1420	1	1	pipe	copper	stainless steel
1430	1	1	male connector	brass	
1440	1	1	reducer	steel	brass
1800	4	4	stud	stainless steel	
1810	4	4	nut	brass	
1815	4	4	washer	steel	
1820*	1	1	cap nut	stainless steel	
1860*	1	1	impeller key	stainless steel	

9.8 Suction bend K1/K3

9.8.1 Sectional drawing suction bend, K1

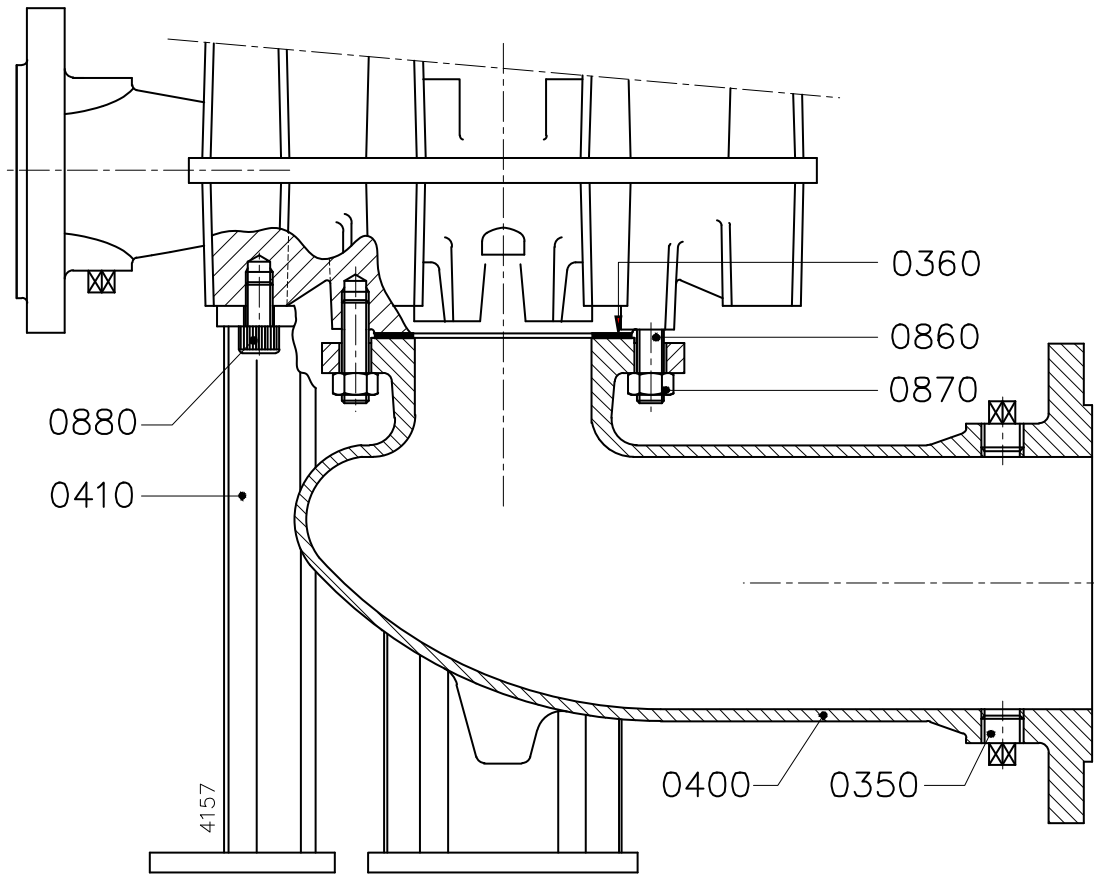

Figure 26: Sectional drawing suction bend, K1.

9.8.2 Parts of suction bend, K1

See figure 26.

Item	Quantity	Description	Material	
			cast iron	bronze
0350	2	plug	steel	stainless steel
0360	1	gasket	--	
0400	1	suction bend	cast iron	bronze
0860	4/8 ^(*)	stud	steel	
0870	4/8 ^(*)	nut	steel	
0410	3	support	steel	
0880	6	Allen screw	steel	

(*) Quantity depends on pump type

9.8.3 Sectional drawing suction bend, K3

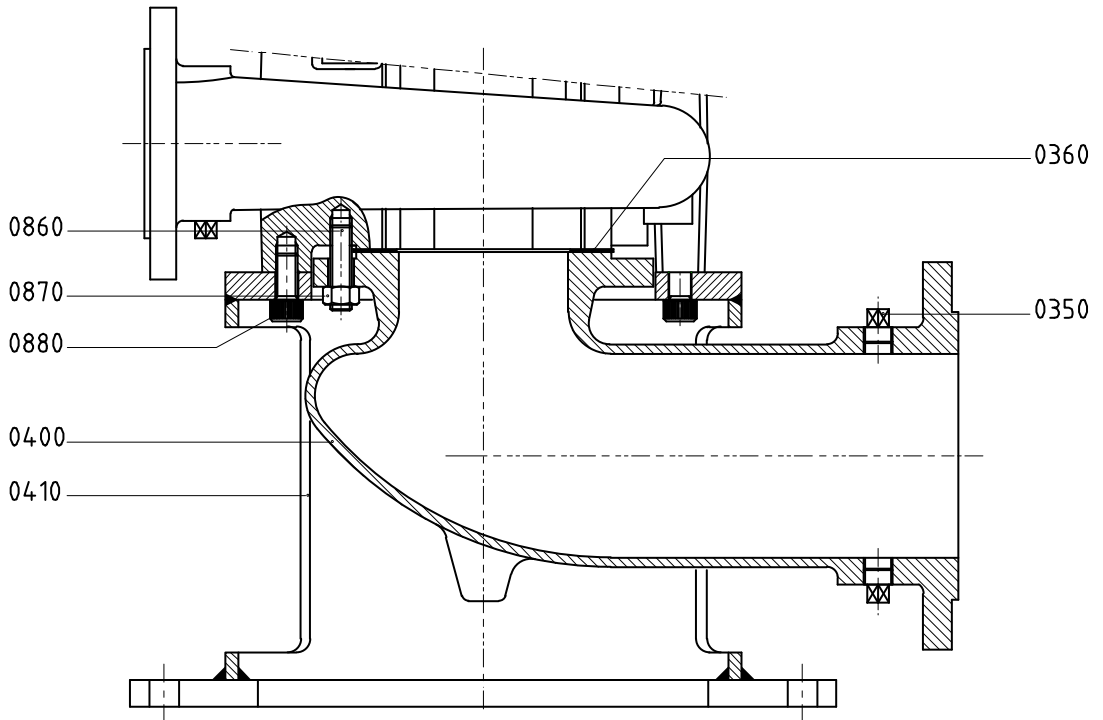

Figure 27: Sectional drawing suction bend, K3.

9.8.4 Parts of suction bend, K3

See figure 27.

Item	Quantity	Description	Material	
			cast iron	bronze
0350	2	plug	steel	stainless steel
0360	1	gasket	--	
0400	1	suction bend	cast iron	bronze
0410	1	support	steel	
0860	4/8 ^(*)	stud	steel	
0870	4/8 ^(*)	nut	steel	
0880	6	Allen screw	steel	

(*) Quantity depends on pump type

10 Technical data

10.1 Bearing groups

10.2 The pump range is divided in a number of bearing groups.

Table 6: Bearing group division.

Bearing groups		
1	2	3
32-160	65-250	80-400
32-200	65-315	100-400
40-160	80-200	125-315
40-200	80-250	125-400
40-250	80-315	150-315
50-160	100-200	150-400
50-200	100-250	250B-315
50-250	100-315	
65-160	125-250	
65-200	200-200	
80-160		

10.3 Mounting media

10.3.1 Recommended mounting grease

Recommended greases for greasing stuffing box packing rings:

- Foliac cup grease (graphite grease)
- Molycote BR2 (graphite grease)
- silicon grease

10.3.2 Recommended locking liquids

Table 7: Recommended locking liquids.

Description	Locking liquid
cap nut (1820)	Loctite 243
throttling bush (1210)	Loctite 641
wear ring (1130)	

10.4 Tightening moments

10.4.1 Tightening moments for bolts and nuts

Table 8: Tightening moments for bolts and nuts.

Materials	8.8	A2, A4
Thread	Tightening moment [Nm]	
M6	9	6
M8	20	14
M10	40	25
M12	69	43
M16	168	105

10.4.2 Tightening moments for cap nut

Table 9: Tightening moments for cap nut (1820).

Size	Tightening moment [Nm]
M12 (bearing group 1)	43
M16 (bearing group 2)	105
M24 (bearing group 3)	220

10.5 Maximum speed

Table 10: Maximum speed

	max. speed [min ⁻¹]
32-160	3600
32-200	3600
40-160	3600
40-200	3600
40-250	3000
50-160	3600
50-200	3600
50-250	3000
65-160	3600
65-200	3600
65A-250	3000
80-160	3600
80-200	3600
80-250	3000
80-400	1800
80A-400	1800
100C-200	3000
100-250	3000
100-400	1800
125-250	1800
125-315	1800
125-400	1800
150-315	1800
150-400	1800
200-200	1800
250B-315	1800

10.6 Pressure in shaft sealing space for shaft sealing groups M1-M2-M3

Pressure in shaft sealing space above the inlet pressure and with an external circulation of medium from the delivery side, calculated for a specific mass of 1000 kg/m³.

Table 11: Pressure in shaft sealing space for shaft sealing groups M1-M2-M3.

	n[min^{-1}]/[bar]									
	900	1200	1500	1800	2100	2400	2700	3000	3300	3600
32-160	0,3	0,4	0,7	1,0	1,3	1,7	2,2	2,6	3,2	3,8
32-200	0,3	0,6	0,9	1,3	1,8	2,4	3,0	3,7	4,5	5,4
40-160	0,2	0,4	0,7	0,9	1,3	1,7	2,1	2,6	3,2	3,8
40-200	0,4	0,7	1,1	1,6	2,2	2,9	3,6	4,5	5,4	6,5
40-250	0,6	1,0	1,6	2,2	3,0	4,0	5,0	6,2		
50-160	0,2	0,4	0,7	1,0	1,3	1,7	2,1	2,7	3,2	3,8
50-200	0,4	0,7	1,0	1,5	2,0	2,6	3,3	4,1	4,9	5,8
50-250	0,6	1,1	1,7	2,4	3,3	4,3	5,4	6,7		
65-160	0,3	0,5	0,7	1,0	1,4	1,8	2,3	2,8	3,4	4,1
65-200	0,4	0,7	1,0	1,5	2,0	2,6	3,3	4,1	5,0	6,0
65A-250	0,5	0,9	1,5	2,1	2,9	3,7	4,7	5,8		
80-160	0,3	0,5	0,8	1,1	1,5	1,9	2,4	3,0	3,6	4,3
80-200	0,3	0,6	0,9	1,3	1,8	2,3	2,9	3,5	4,3	5,1
80-250	0,6	1,0	1,6	2,3	3,1	4,1	5,2	6,4	7,7	
80-400	1,1	1,9	3,0	4,3	5,9	7,6	9,7			
80A-400	1,1	1,9	3,0	4,3	5,9	7,6	9,7			
100C-200	0,4	0,7	1,0	1,5	2,0	2,6	3,3	4,1		
100-250	0,5	1,0	1,5	2,2	3,0	3,9	4,9	6,0		
100-400	1,2	2,2	3,4	4,9	6,6	8,6	9,3			
125-250	0,5	1,0	1,5	2,2	3,0	3,5	4,0	4,4		
125-315	0,8	1,4	2,2	3,1	4,2	5,5	5,6	5,1		
125-400	1,2	2,1	3,2	4,7	5,4	6,3	7,1			
150-315	0,8	1,4	2,2	3,2	3,0					
150-400	1,3	2,3	3,6	4,2	5,0					
200-200	0,5	0,8	1,3	1,6						
250B-315	0,6	1,1	1,7	2,5	3,4	3,7				

10.7 Pressure near the impeller hub for shaft sealing groups S2-S3-S4

Pressure near the impeller hub above the inlet pressure, calculated for a specific mass of 1000 kg/m³.

Table 12: Pressure near the impeller hub for shaft sealing groups S2-S3-S4.

	n[min^{-1}]/[bar]									
	900	1200	1500	1800	2100	2400	2700	3000	3300	3600
32-160	0,1	0,2	0,4	0,6	0,8	1,0	1,2	1,5	1,9	2,2
32-200	0,1	0,2	0,4	0,5	0,7	0,9	1,2	1,4	1,7	2,1
40-160	0,1	0,1	0,2	0,3	0,4	0,6	0,7	0,9	1,1	1,3
40-200	0,2	0,4	0,6	0,9	1,3	1,6	2,1	2,5	3,1	3,7
40-250	0,3	0,4	0,7	1,0	1,4	1,8	2,3	2,8		
50-125	0,0	0,1	0,1	0,2	0,2	0,3	0,4	0,5	0,5	0,6
50-160	0,1	0,2	0,2	0,4	0,5	0,6	0,8	1,0	1,2	1,4
50-200	0,1	0,2	0,3	0,5	0,6	0,8	1,0	1,3	1,5	1,8
65-125	0,0	0,0	0,0	0,0	0,0	0,0	0,1	0,1	0,1	0,1
65-160	0,0	0,1	0,1	0,1	0,2	0,2	0,3	0,4	0,4	0,5
65-200	0,1	0,2	0,3	0,5	0,6	0,8	1,0	1,3	1,5	1,8
65A-250	0,2	0,3	0,5	0,7	1,0	1,3	1,6	2,0		
80-160	0,0	0,0	0,0	0,0	0,0	0,0	0,2	0,3	0,0	0,0
80-200	0,0	0,0	0,1	0,1	0,1	0,2	1,3	1,6	0,4	0,4
80-250	0,1	0,3	0,4	0,6	0,8	1,0			1,9	
80-400	0,4	0,6	1,0	1,4	2,0	2,6	0,0	0,0		
80A-400	0,4	0,6	1,0	1,4	2,0	2,6	0,0	0,0		
100C-200	0,0	0,1	0,1	0,2	0,2	0,3	0,7	0,8		
100-250	0,1	0,1	0,2	0,3	0,4	0,5				
100-400	0,6	1,1	1,7	2,5	3,4	4,4	0,0			
125-250	0,1	0,1	0,2	0,3	0,4	0,6	1,8	2,2		
125-315	0,2	0,4	0,6	0,8	1,1	1,4	3,6			
125-400	0,4	0,7	1,1	1,6	2,2	2,8	1,3			
150-315	0,1	0,2	0,4	0,5	0,7					
150-400	0,4	0,6	1,0	1,4	1,9		0,2			
200-200	0,0	0,0	0,0	0,1			0,5	0,0		
250B-315	0,1	0,2	0,4	0,5	0,7	0,3				

10.8 Hydraulic performance

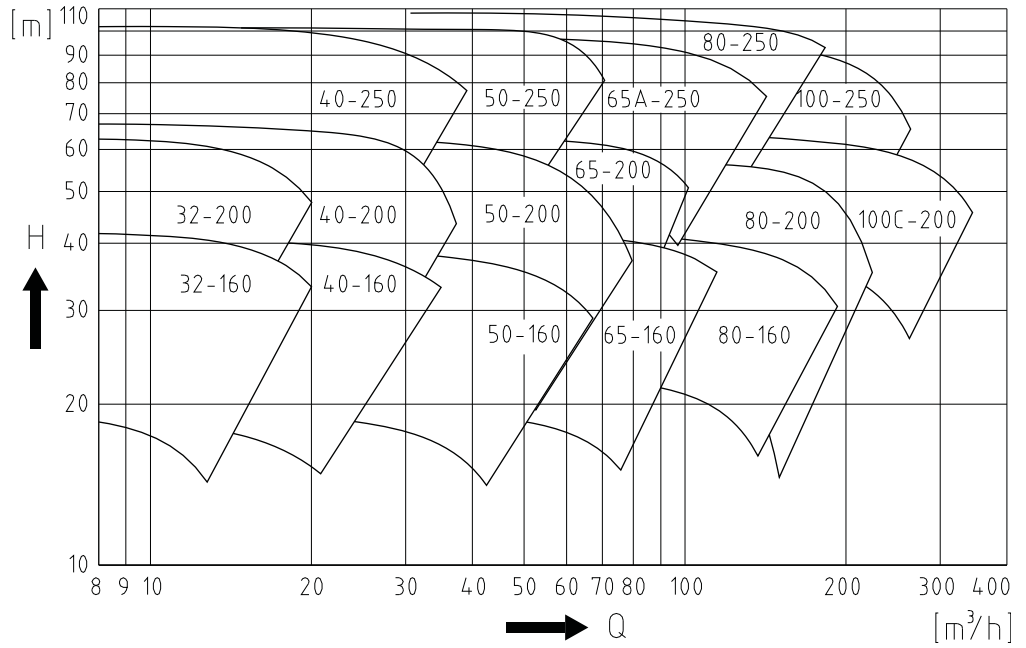

Figure 28: Performance overview 3000 min⁻¹

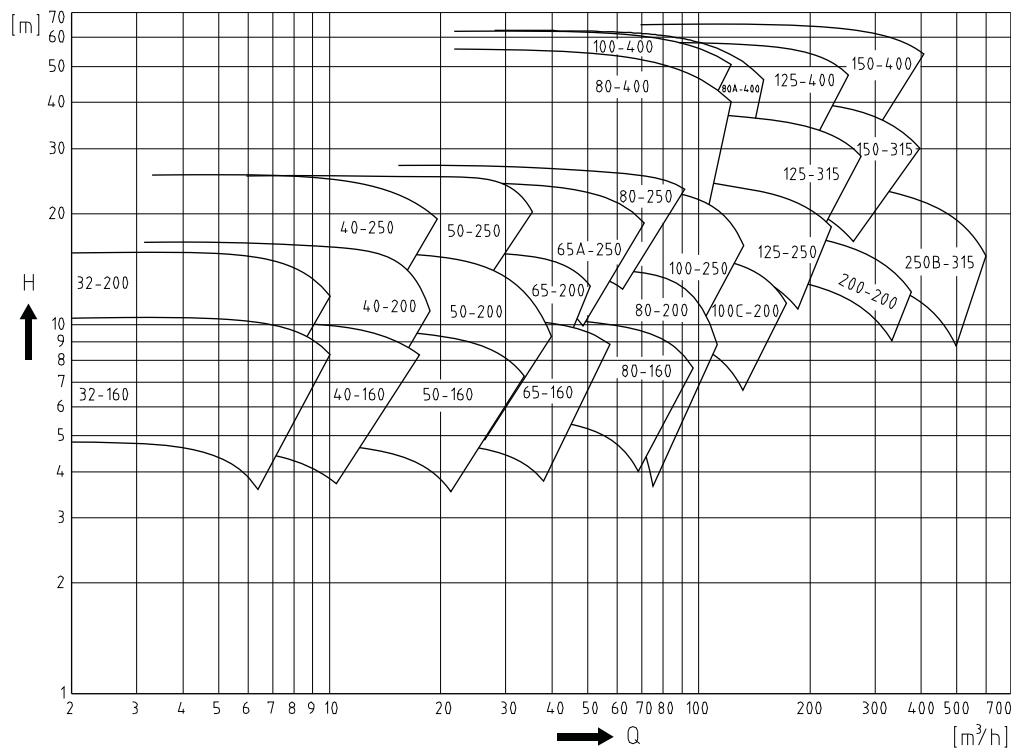

Figure 29: Performance overview 1500 min⁻¹

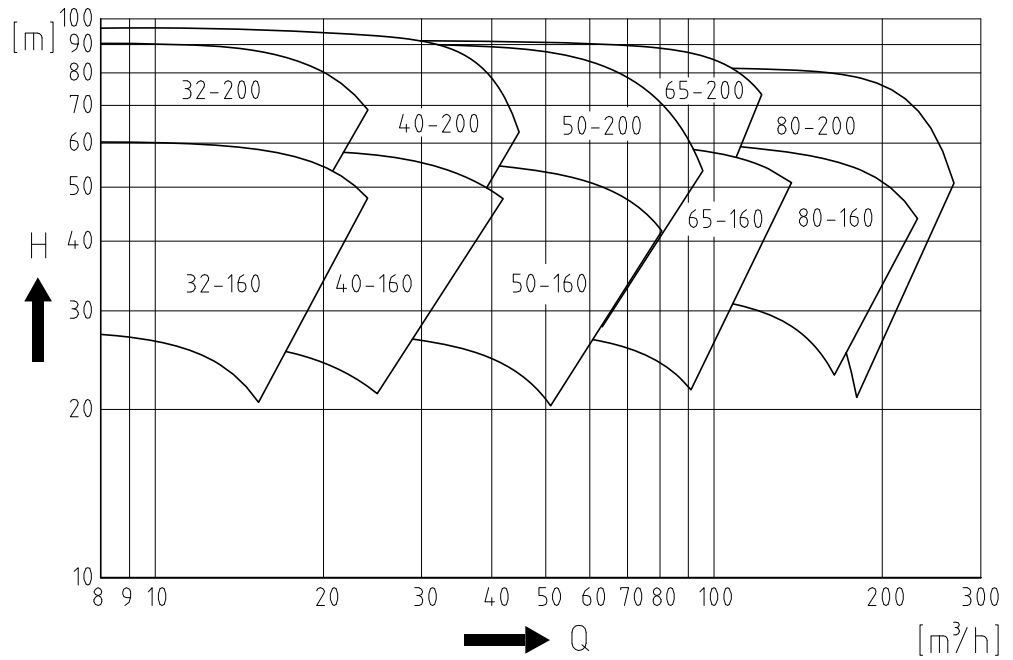

Figure 30: Performance overview 3600 min⁻¹

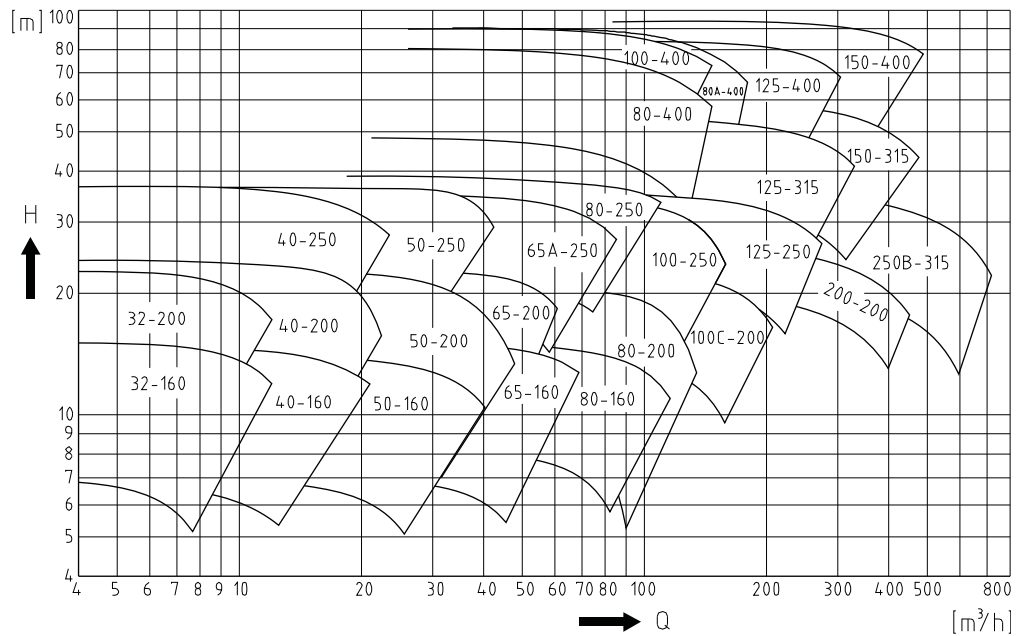

Figure 31: Performance overview 1800 min⁻¹

10.9 Noise data

10.9.1 Pump noise as a function of pump power

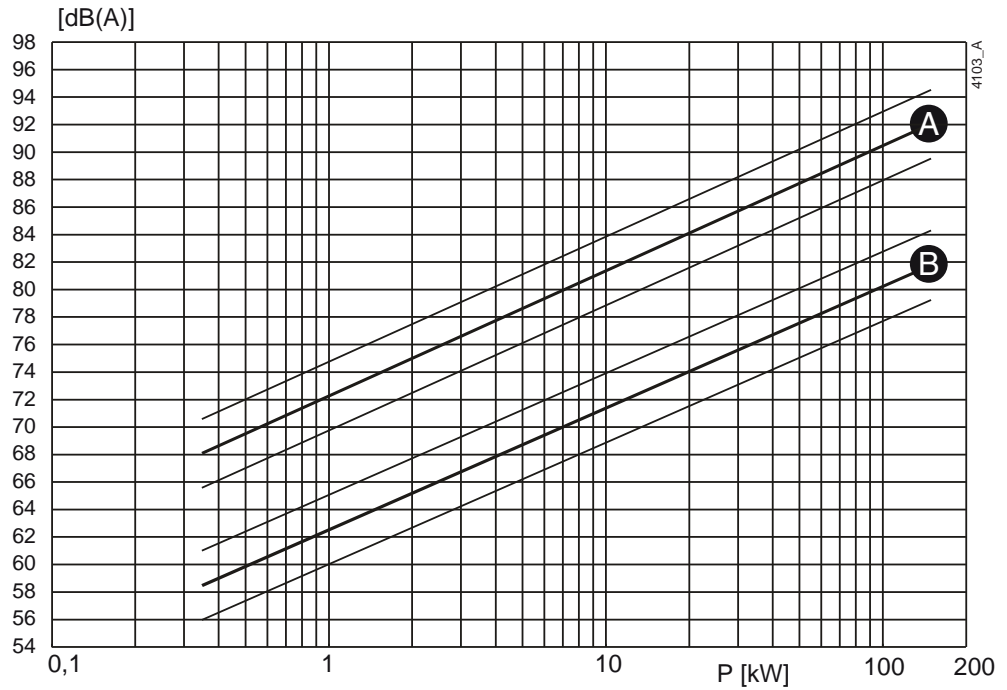

Figure 32: Noise level as function of pump power [kW] at 1450 min⁻¹
A = sound energy, B = sound pressure.

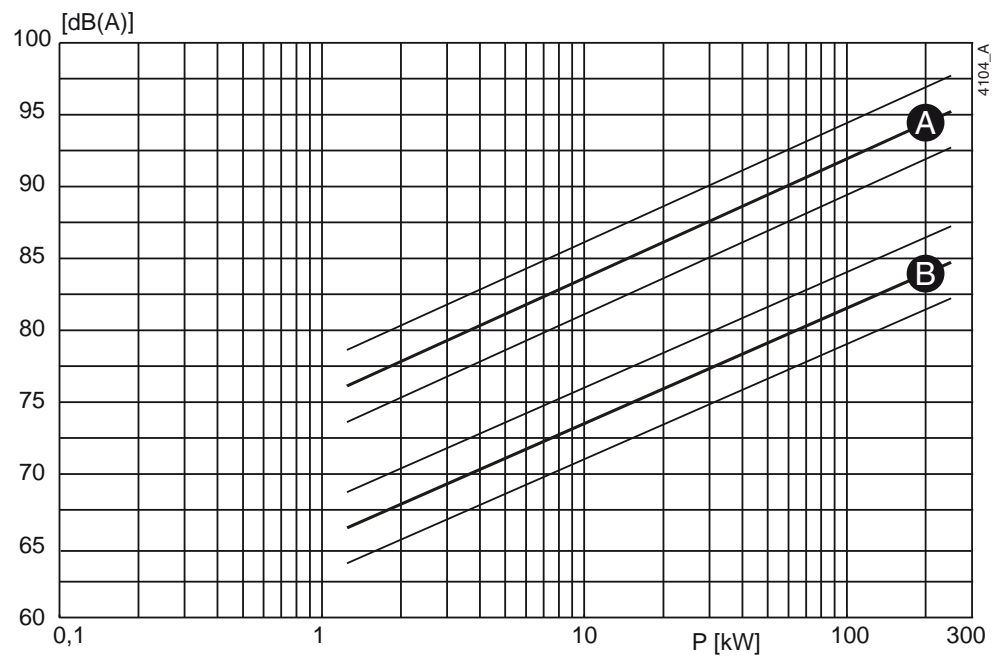

Figure 33: Noise level as function of pump power [kW] at 2900 min⁻¹
A = sound energy, B = sound pressure.

10.9.2 Noise level of entire pump unit

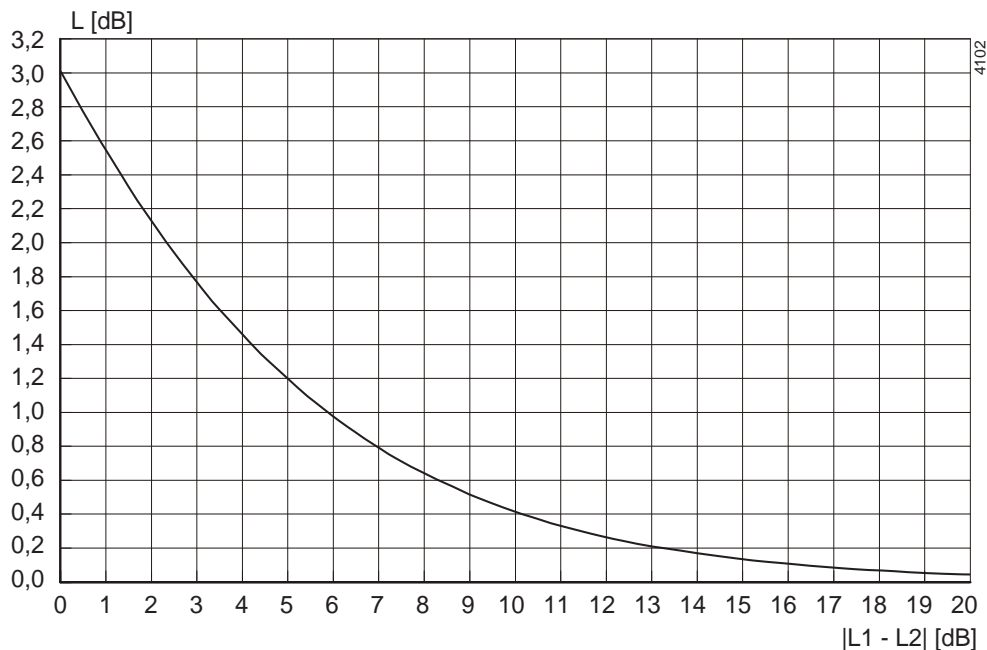

Figure 34: Noise level of entire pump unit.

In order to determine the total noise level of the entire pump unit, the noise level of the motor must be added to that of the pump. This can be easily done by using the graph above.

- 1 Determine the noise level (L1) of the pump, see figure 32 or figure 33.
- 2 Determine the noise level (L2) of the motor, see documentation of the motor.
- 3 Determine the difference between both levels $|L1 - L2|$.
- 4 Find the differential value on the $|L1 - L2|$ -axis and go up to the curve.
- 5 From the curve go left to the L[dB] -axis and read out the value.
- 6 Add this value to the highest value of both noise levels (L1 or L2).

Example:

- 1 Pump 75 dB; motor 78 dB.
- 2 $|75-78| = 3$ dB.
- 3 3 dB on the X-axis = 1,75 dB on the Y-axis.
- 4 Highest noise level + 1,75 dB = $78 + 1,75 = 79,75$ dB.

Index

A

Application area	15
Applications	14

B

Bearing groups	14, 61
Bearings	
lubrication	21

C

Commissioning	19
Construction	14
dry part	14
pump casing/impeller/suction bend	14
shaft sealing	14
Construction variants	25

D

Daily maintenance	
mechanical seal	21
stuffing box packing	21

E

Earthing	17
Environment	17
Environmental influences	21

F

Faults	22
Flushing liquid	21
Foundation	17

G

Guarantee	10
-----------------	----

H

Hoisting	11
----------------	----

I

Inspection	
pump	19

L

Lifting eye	11
Liquid draining	25
Liquid level	19, 67

M

Maintenance staff	9
Max. allowable working pressure	67
Mechanical seal	20
assembly instructions	32
with Teflon covered O-ring	32
Mechanical seal M1	
assembly	34
disassembly	34
Mechanical seal M2-M3	
assembly	36
disassembly	35
Motor	
replacing	37

N

Noise	20, 22
-------------	--------

O

Operational range	67
-------------------------	----

P

Pallets	10
Piping	18
Precautionary measures	25
Pump description	13

R

Recommended grease	
for stuffing box packing	61
Recommended greases	61
Recommended locking liquid	61
Recommended mounting grease	61
Regular maintenance	21
Re-use	15

S	
Safety	9, 17
symbols	9
Scrapping	15
Sense of rotation	19
Serial number	14
Shaft sleeve	
assembly	31
disassembly	31
Special tools	25, 34
Start-up	19
Static electricity	17
Storage	10, 11
Stub shaft	
adjusting	38
assembling	38
disassembling	37
replacing	37
Stuffing box packing	
assembly instructions	29
mounting	30
removal	30
removal instructions	29
T	
Technicians	9
Tightening moments	
for bolts and nuts	62
for cap nut	62
Transport	10
Type description	13
V	
Ventilation	17
W	
Wear ring	
assembly	28
disassembly	28
Working switch	18

CombiFlexBloc

Vertical centrifugal pump in monobloc
execution



SPX Flow Technology Assen B.V.
Dr. A. F. Philipsweg 51, 9403 AD Assen, THE NETHERLANDS
Phone: + 31 (0) 592 37 67 67 Fax: + 31 (0) 592 37 67 60
E-Mail: johnson-pump.nl@spx.com
www.johnson-pump.com
www.spx.com

For more information about our worldwide locations, approvals, certifications, and local representatives, please visit www.johnson-pump.com.

SPX Corporation reserves the right to incorporate our latest design and material changes without notice or obligation. Design features, materials of construction and dimensional data, as described in this bulletin, are provided for your information only and should not be relied upon unless confirmed in writing.

ISSUED 11/2011 DV-1530
Copyright © 2011 SPX Corporation