

Solids Flowmeters

SITRANS WF340

Operating Instructions · 10/2011



SITRANS

SIEMENS

Safety Guidelines

Warning notices must be observed to ensure personal safety as well as that of others, and to protect the product and the connected equipment. These warning notices are accompanied by a clarification of the level of caution to be observed.

Qualified Personnel

This device/system may only be set up and operated in conjunction with this manual. Qualified personnel are only authorized to install and operate this equipment in accordance with established safety practices and standards.

Unit Repair and Excluded Liability:

- The user is responsible for all changes and repairs made to the device by the user or the user's agent.
- All new components are to be provided by Siemens Milltronics Process Instruments.
- Restrict repair to faulty components only.
- Do not reuse faulty components.

Warning: Cardboard shipping package provides limited humidity and moisture protection. This product can only function properly and safely if it is correctly transported, stored, installed, set up, operated, and maintained.

This product is intended for use in industrial areas. Operation of this equipment in a residential area may cause interference to several frequency based communications.

Note: Always use product in accordance with specifications.

Copyright Siemens AG 2011. All Rights Reserved	Disclaimer of Liability
This document is available in bound version and in electronic version. We encourage users to purchase authorized bound manuals, or to view electronic versions as designed and authored by Siemens Milltronics Process Instruments. Siemens Milltronics Process Instruments will not be responsible for the contents of partial or whole reproductions of either bound or electronic versions.	While we have verified the contents of this manual for agreement with the instrumentation described, variations remain possible. Thus we cannot guarantee full agreement. The contents of this manual are regularly reviewed and corrections are included in subsequent editions. We welcome all suggestions for improvement. Technical data subject to change.

MILLTRONICS® is a registered trademark of Siemens Milltronics Process Instruments.

Contact SMPI Technical Publications at the following address:

Technical Publications
Siemens AG
Siemens Milltronics Process Instruments
1954 Technology Drive, P.O. Box 4225
Peterborough, Ontario, Canada, K9J 7B1
Email: techpubs.smpi@siemens.com

European Authorized Representative

Siemens AG
Industry Sector
76181 Karlsruhe
Deutschland

- For a selection of Siemens Milltronics level measurement manuals, go to: **www.siemens.com/processautomation**. Under Process Instrumentation, select *Level Measurement* and then go to the manual archive listed under the product family.
- For a selection of Siemens Milltronics weighing manuals, go to: **www.siemens.com/processautomation**. Under Weighing Technology, select *Continuous Weighing Systems* and then go to the manual archive listed under the product family.

SIEMENS

SITRANS

Solids Flowmeters SITRANS WF340

Operating Instructions

<u>Introduction</u>	1
<u>Safety notes</u>	2
<u>Description</u>	3
<u>Installing/mounting</u>	4
<u>Service and maintenance</u>	5
<u>Technical data</u>	6
<u>Dimension drawings</u>	7
<u>Application examples</u>	8

Legal information

Warning notice system

This manual contains notices you have to observe in order to ensure your personal safety, as well as to prevent damage to property. The notices referring to your personal safety are highlighted in the manual by a safety alert symbol, notices referring only to property damage have no safety alert symbol. These notices shown below are graded according to the degree of danger.

⚠ DANGER
indicates that death or severe personal injury will result if proper precautions are not taken.

⚠ WARNING
indicates that death or severe personal injury may result if proper precautions are not taken.

⚠ CAUTION
with a safety alert symbol, indicates that minor personal injury can result if proper precautions are not taken.

CAUTION
without a safety alert symbol, indicates that property damage can result if proper precautions are not taken.

NOTICE
indicates that an unintended result or situation can occur if the relevant information is not taken into account.

If more than one degree of danger is present, the warning notice representing the highest degree of danger will be used. A notice warning of injury to persons with a safety alert symbol may also include a warning relating to property damage.

Qualified Personnel

The product/system described in this documentation may be operated only by **personnel qualified** for the specific task in accordance with the relevant documentation, in particular its warning notices and safety instructions. Qualified personnel are those who, based on their training and experience, are capable of identifying risks and avoiding potential hazards when working with these products/systems.

Proper use of Siemens products

Note the following:

⚠ WARNING
Siemens products may only be used for the applications described in the catalog and in the relevant technical documentation. If products and components from other manufacturers are used, these must be recommended or approved by Siemens. Proper transport, storage, installation, assembly, commissioning, operation and maintenance are required to ensure that the products operate safely and without any problems. The permissible ambient conditions must be complied with. The information in the relevant documentation must be observed.

Trademarks

All names identified by ® are registered trademarks of Siemens AG. The remaining trademarks in this publication may be trademarks whose use by third parties for their own purposes could violate the rights of the owner.

Disclaimer of Liability

We have reviewed the contents of this publication to ensure consistency with the hardware and software described. Since variance cannot be precluded entirely, we cannot guarantee full consistency. However, the information in this publication is reviewed regularly and any necessary corrections are included in subsequent editions.

Table of contents

1	Introduction.....	5
1.1	The manual	5
2	Safety notes.....	7
2.1	General safety instructions	7
3	Description.....	9
3.1	SITRANS WF340.....	9
4	Installing/mounting.....	11
4.1	Location.....	11
5	Service and maintenance	13
5.1	Maintenance.....	13
5.2	Technical support.....	13
6	Technical data	15
6.1	Specifications	15
7	Dimension drawings	17
7.1	SITRANS WF340 40 t/h version - outline and mounting	17
7.2	SITRANS WF340 300 t/h version - outline and mounting	20
8	Application examples.....	23
8.1	Materials.....	23
8.2	Material feed	24
8.3	Flowmeter in-feed chutes.....	26
8.4	Flowguide capacity	31

Introduction

Note

The Siemens solids flowmeter is to be used only in the manner outlined in this manual, otherwise protection provided by equipment may be impaired.

- It is your responsibility to read this manual before installing and starting up any component of the weighing system to which the flowmeter is being applied.
-

NOTICE
For industrial use only
This product is intended for use in industrial areas. Operation of this equipment in a residential area may cause interference to several frequency based communications.

1.1 The manual

This manual covers only flowmeter installation, operation, and maintenance procedures. Sensing head and integrator instruction manuals are available for download from our web site:

Siemens weighing (<http://www.siemens.com/weighing>)

Follow these operating instructions for quick, trouble-free installation, and maximum accuracy and reliability of your weighing system.

We always welcome suggestions and comments about manual content, design, and accessibility. Please direct your comments to:

Technical publications (<mailto:techpubs.smpi@siemens.com>)

Safety notes

2.1 General safety instructions

 CAUTION

Correct, reliable operation of the product requires proper transport, storage, positioning and assembly as well as careful operation and maintenance. Only qualified personnel should install or operate this instrument.

Note

Alterations to the product, including opening or improper repairs of the product, are not permitted.

If this requirement is not observed, the CE mark and the manufacturer's warranty will expire.

Safety notes

2.1 General safety instructions

Description

3.1 SITRANS WF340

SITRANS WF340 solids flowmeters are compact vertical, low- to medium-capacity flowmeters for various product sizes, densities and fluidities, particularly fine powders. The 40 t/h version, combined with a SITRANS WFS300 sensing head, is suitable for material flowrates up to 40 t/h (44 STPH). The 300 t/h version with a SITRANS WFS320 sensing head is suitable for up to 300 t/h (330 STPH).

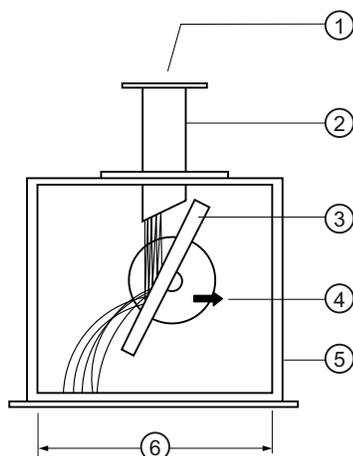

- | | | | |
|---|---------------|---|--------------------|
| ① | Material feed | ④ | Impact force |
| ② | Flowguide | ⑤ | Housing |
| ③ | Sensing plate | ⑥ | Material discharge |

The flowmeter sensing head LVDT output signal is processed by the integrator (ordered separately) to:

- monitor material flow
- maintain accurate material inventory
- provide batch control for process or loadout purposes¹
- control the ratio of materials in continuous blending processes¹

¹additional equipment required

Description

3.1 SITRANS WF340

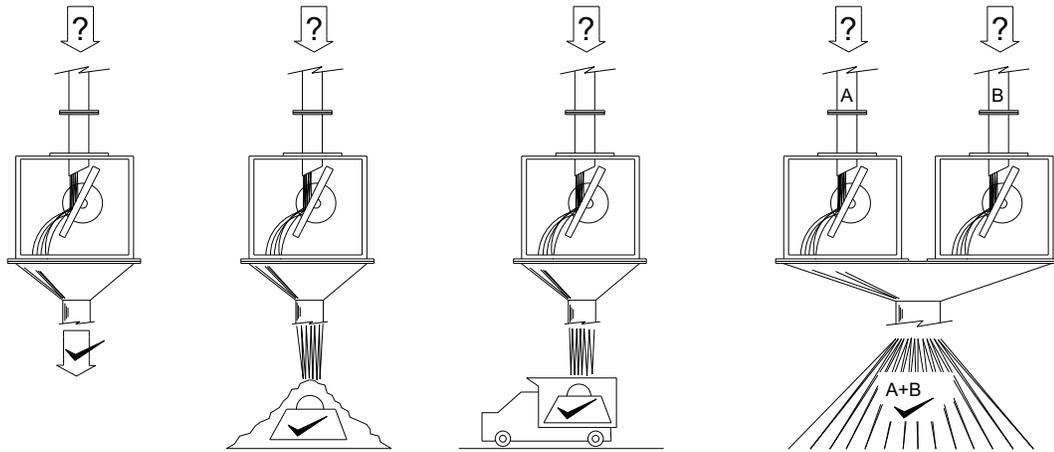

System components

Components of the SITRANS WF340 solids flowmeter system include:

- SITRANS WF340 flowmeter housing and flowguide
- SITRANS WFS300 or WFS320 sensing head (ordered separately)
- stainless steel sensing plate (ordered separately)
- electronic flowmeter integrator (ordered separately)

Installing/mounting

4.1 Location

Install SITRANS WF340 in an area that is suitable for the system approval rating. Position the flowmeter to permit opening the sensing plate housing door for sensing plate access, and removing the sensing head rear cover for calibration purposes.

Ensure the flowmeter inlet and outlet mounting points are free from vibration. If vibration is expected, use a base mounted sensing head if using the 40 t/h version of WF340.

1. Position the flowmeter into the desired location.
2. If necessary, shim the housing base to level.
3. Fasten the housing discharge to the downstream material chute.
4. Fasten the flowguide to the material infeed chute.
5. Refer to SITRANS WFS300 or WFS320 operating instructions for sensing head installation, levelling, sensing plate installation, and integrator interconnection instructions.

Note

Provide sufficient mechanical support for the flowmeter and chutework.

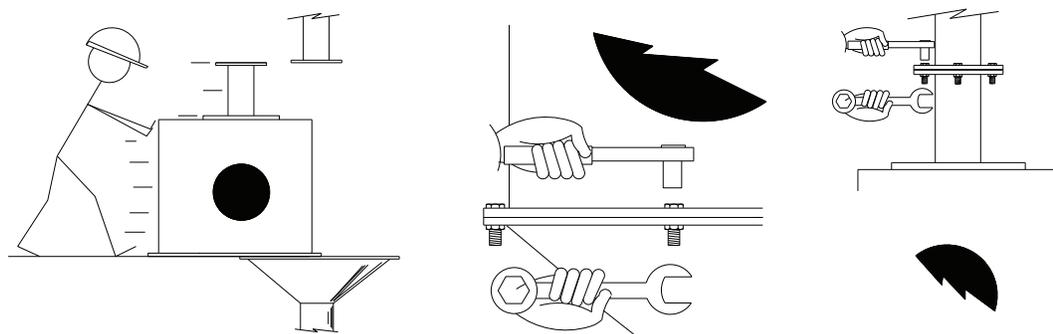

Note

To prevent accidental damage, temporarily remove the sensing head (side mount versions only) if the flowmeter cannot be easily positioned.

Service and maintenance

5.1 Maintenance

If material sticks to the sensing plate, incorporate a program to ensure that the impingement area remains clean. If sticking persists, contact your Siemens representative.

Check for wearing of the sensing plate. If wear is excessive, contact your Siemens representative.

Unit repair and excluded liability

All changes and repairs must be done by qualified personnel and applicable safety regulations must be followed. Please note the following:

- The user is responsible for all changes and repairs made to the device.
- All new components must be provided by Siemens.
- Restrict repair to faulty components only.
- Do not re-use faulty components.

5.2 Technical support

If you have any technical questions about the device described in these Operating Instructions and do not find the right answers, you can contact Customer Support:

- Via the Internet using the **Support Request**:

Support request (<http://www.siemens.com/automation/support-request>)

- Via Phone:
 - Europe: +49 (0)911 895 7222
 - America: +1 423 262 5710
 - Asia-Pacific: +86 10 6475 7575

Further information about our technical support is available on the Internet at

Technical support (<http://support.automation.siemens.com/WW/view/en/16604318>)

Service & Support on the Internet

In addition to our documentation, we offer a comprehensive knowledge base online on the Internet at:

Service & Support (<http://www.siemens.com/automation/service&support>)

There you will find:

- The latest product information, FAQs, downloads, tips and tricks.
- Our newsletter, providing you with the latest information about your products.
- Our bulletin board, where users and specialists share their knowledge worldwide.
- You can find your local contact partner for Industry Automation and Drives Technologies in our partner database.
- Information about field service, repairs, spare parts and lots more under "Services."

Additional Support

Please contact your local Siemens representative and offices if you have additional questions about the device

Find your contact partner at:

Local contact person (<http://www.siemens.com/automation/partner>)

Technical data

6.1 Specifications

Model

 40 t/h version

 300 t/h version

Product

 40 t/h version

 fine powder up to 13 mm (0.5")

 300 t/h version

 fine powder up to 25 mm (1")

Product temperature

 -40 to +232 °C (-40 to +450 °F)

Ambient temperature

 -40 to +60 °C (-40 to +140 °F)

Accuracy

 ±1 %, 33 to 100 % of design capacity; extended accuracy range with linearization function of integrator

Accuracy subject to: on factory approved installations the flowmeter system's totalized weight will be within the specified accuracy when compared to a known weighed material test sample. The test rate must be within the specified range of the design capacity and held constant for the duration of the test. The minimum material test sample must be equivalent to a sample obtained at the test flow rate for at least ten minutes running time.

Technical data

6.1 Specifications

Repeatability

±0.2 %

Capacity range

40 t/h version	0.2 to 40 t/h (0.2 to 44 STPH)
300 t/h version	20 to 300 t/h (22 to 330 STPH)

Construction

painted mild steel flowguide and sensing plate housing and AISI 304 (1.4306) stainless steel sensing plate

optional special materials and coatings for flowguide and sensing plate

Approvals

General	CE, C-TICK
---------	------------

Stainless steel options meet FDA and USDA requirements for food processing.

Dimension drawings

7.1 SITRANS WF340 40 t/h version - outline and mounting

Dimension drawings

7.1 SITRANS WF340 40 t/h version - outline and mounting

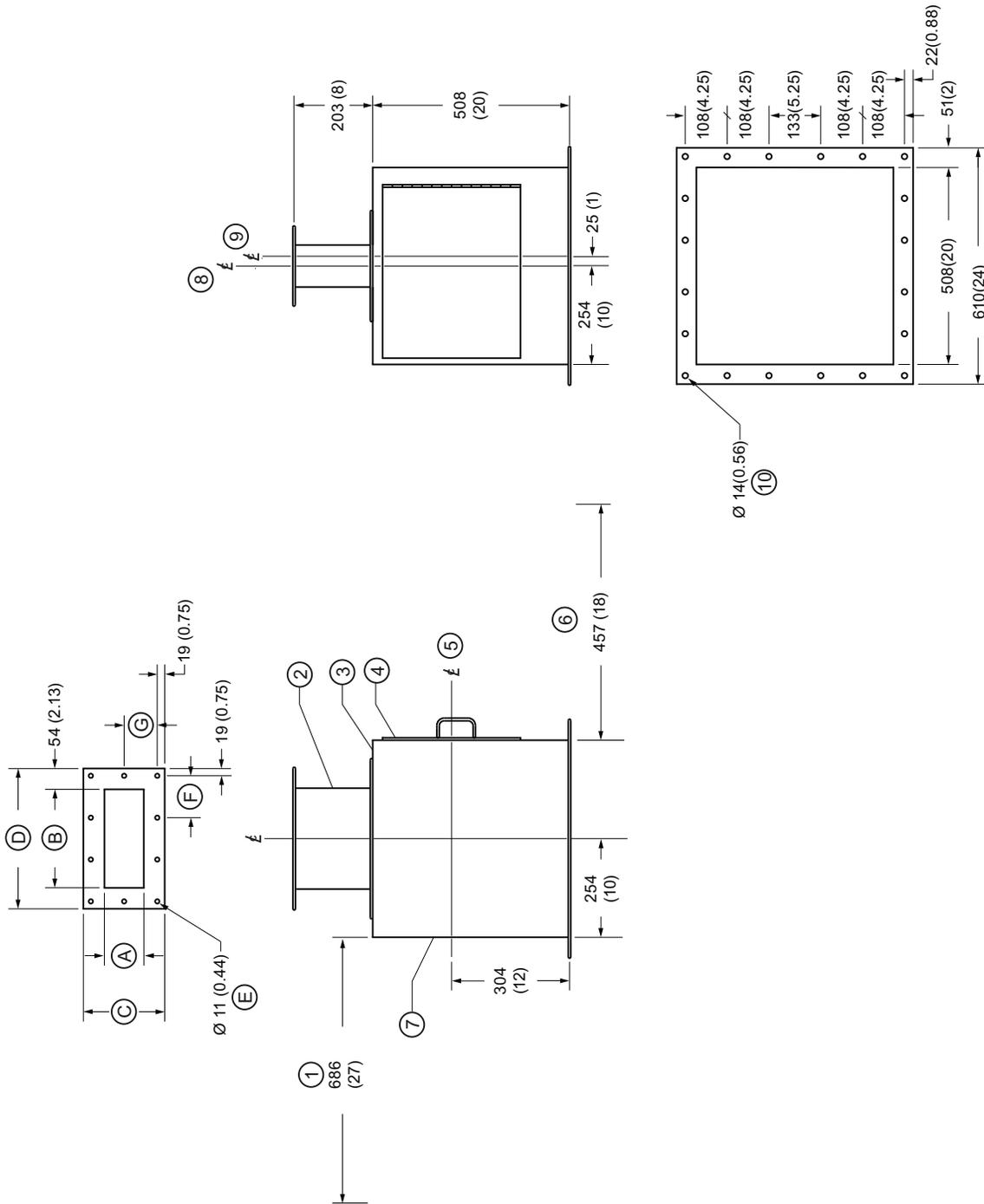

Figure 7-1 SITRANS WF340, 40 t/h version. Dimensions in mm (in)

7.1 SITRANS WF340 40 t/h version - outline and mounting

- | | | | |
|---|-------------------------------------------------|---|--------------------------------------------------|
| ① | Minimum allowance for sensing head installation | ⑥ | Minimum allowance for sensing plate installation |
| ② | Flowguide | ⑦ | Access and bolt holes to suit sensing head |
| ③ | Housing | ⑧ | Discharge center line |
| ④ | Access door | ⑨ | Sensing head center line |
| ⑤ | Sensing head center line | ⑩ | 20 holes |

Size	A	B	C	D	E	F	G
1	76 (3)	152 (6)	184 (7.25)	260 (10.25)	8	111 (4.38)	73 (2.88)
2	102 (4)	254 (10)	210 (8.25)	362 (14.25)	10	108 (4.25)	86 (3.38)
3	127 (5)	305 (12)	235 (9.25)	413 (16.25)	12	94 (3.69)	99 (3.88)

Dimensions in mm (in)

Note

- Mild steel or stainless construction.
- Sensing head support should be rigid and independent of housing.

7.2 SITRANS WF340 300 t/h version - outline and mounting

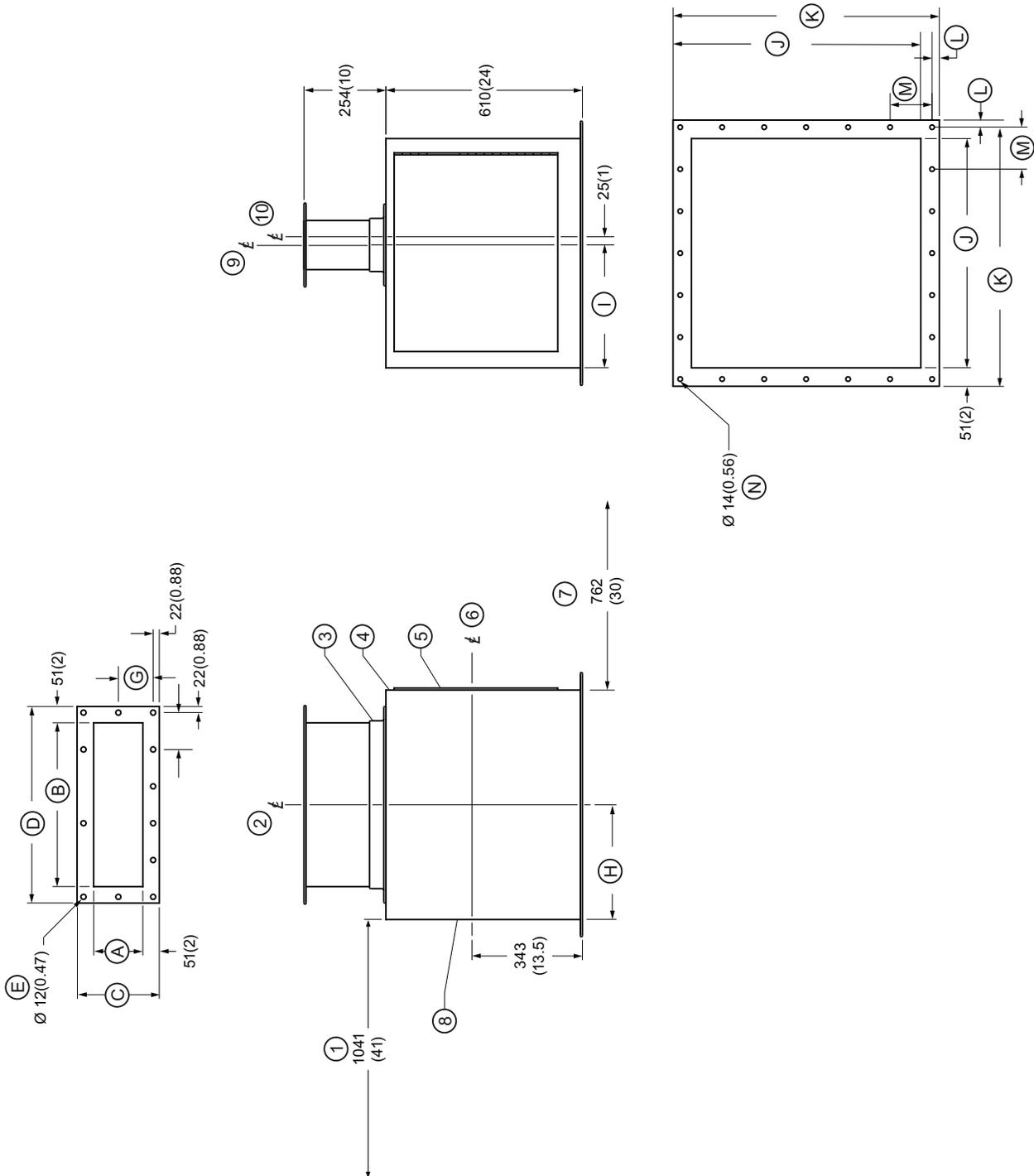

Figure 7-2 SITRANS WF340, 300 t/h version. Dimensions in mm (in)

- | | | | |
|---|-------------------------------------------------|---|--------------------------------------------------|
| ① | Minimum allowance for sensing head installation | ⑥ | Sensing head center line |
| ② | Flowguide center line | ⑦ | Minimum allowance for sensing plate installation |
| ③ | Flowguide | ⑧ | Access and bolt holes to suit sensing head |
| ④ | Housing | ⑨ | Flowguide center line |
| ⑤ | Access door | ⑩ | Sensing head center line |

Size	A	B	C	D	E	F	G	H	I	J	K	L	M	N
1	127 (5)	406 (16)	235 (9.25)	515 (20.25)	12	118 (4.63)	95 (3.75)	308 (12.12)	330 (13)	616 (24.25)	718 (28.25)	17 (0.69)	137 (5.38)	20
2	152 (6)	508 (20)	260 (10.25)	616 (24.25)	14	114 (4.5)	108 (4.25)	359 (14.12)	381 (15)	718 (28.25)	819 (32.25)	19 (0.75)	130 (5.125)	24

Dimensions in mm (in)

Note

- Mild steel or stainless construction.
- Sensing head support should be rigid and independent of housing.

Dimension drawings

7.2 SITRANS WF340 300 t/h version - outline and mounting

Application examples

Note

For best performance and limited maintenance requirements, keep in mind material compatibility and flow patterns.

8.1 Materials

Material characteristics for best results:

- low cohesion (flows well through chutes, like a liquid)
- low adhesion (does not stick to surfaces)
- low abrasion (will not wear out chutes, flowguide, or sensing plate)
- low causticity (will not damage internal flowmeter components)

Most materials with low moisture content have excellent flow and adhesion characteristics. In processes where material moisture content varies, select a flowmeter location where the moisture content is lowest.

Use sensing plate and flowguide non-stick linings for ammonium nitrate, cocoa, fertilizer, wheat flour, gluten, laundry detergent, sugar, and other materials with similar properties.

Abrasive materials are best monitored at low velocity. Use sensing plate and flowguide abrasion resistant linings for alumina, asbestos, barley, carbide, corn, clinker, limestone, perlite ore, and other materials with similar hardness, and particle mass.

Standard flowmeter components are resistant to chemical reaction with most materials. Use special paint or coatings on exposed flowmeter components for ammonium nitrate, carbide, fertilizer, phosphate, salt, sodium chloride, sodium sulphate, and other materials with similar properties.

8.2 Material feed

Ideal material infeed characteristics:

- constant and relatively low material velocity
- uniform material flowrate (not pulsing)
- negligible air flow through the flowmeter
- flowguide 17 to 70 % full during operation

For best results, use material from an elevated bin, gravity fed to the flowmeter. If the material is to be monitored after some process has been performed, choose the feeder device that provides the most consistent material flow.

Use a reverse flowguide transition when high or variable velocity feeder material discharges are anticipated. Refer to Flowmeter in-feed chutes (Page 26). Position the flowmeter discharge chute so material cannot back up into the flowmeter housing.

Use a heavier flowmeter sensing head range spring and/or viscous damper fluid to compensate for slight to moderate material pulsing at greater than 1 pulse per second. For heavily pulsing feeder discharges, at less than 1 pulse per second, consult your local Siemens representative.

Screw conveyor

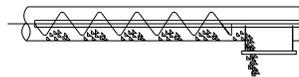

- ① short pitch
- ② double flight

- most common type of material feeder
- short pitch and/or double flight screws preferred to reduce the batch size (and increase the frequency) of the material discharge pulse, or cut back the flights of a standard screw so it ends before the discharge opening
- use reverse flowguide transition for variable operating speeds or constant speeds above 40 rpm

Rotary feeder

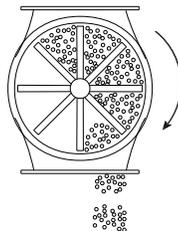

- provides an air seal between the upstream and/or downstream process, and the flowmeter
- required if the material is pneumatically conveyed or flowmeter/process isolation is required
- use reverse flowguide transition for variable operating speeds or constant speeds above 10 rpm

Bucket elevators

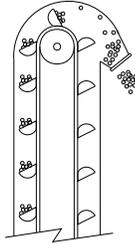

- commonly used for grain applications
- feeder discharge damping required when slow elevators (typically chain drive) produce heavily pulsing material discharge
- use deadbox if required to reduce material velocity from fast elevators (typically re-inforced belt drive)

Conveyor belt

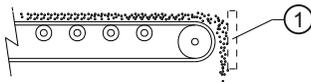

① material discharge baffle

- produces a non-pulsing material discharge
- reverse flowguide transition (and/or material discharge baffle) often required for variable belt speeds or constant speeds in excess of 1 m/s (200 feet/minute)

Drag conveyor

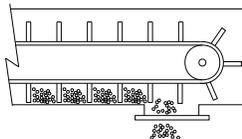

- operates at a constant (and relatively low) velocity
- reverse flowguide transition not normally required but use feeder discharge damping or a discharge baffle to minimize the pulsing material discharge

Vibratory feeder

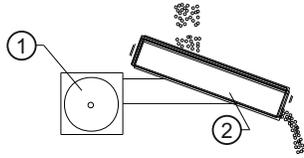

- ① motor
- ② vibrating pan

- produces a non-pulsing material discharge
- use reverse flowguide transition for variable speed varieties

8.3 Flowmeter in-feed chutes

Flowmeter in-feed chutes

The flowmeter in-feed chute delivers the material from the bin or feeder discharge to the flowmeter flowguide. The ideal in-feed chute pre-conditions the material flow to minimize the effect of abrasion, velocity variation, feeder discharge trajectory variation, and pulsing.

Feeder/flowguide transition

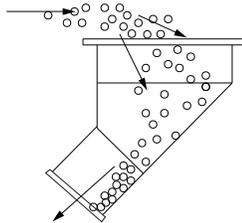

- reverse flowguide transition reverses direction of the bin or feeder material discharge before the material enters the flowmeter flowguide
- reversing direction forces the material into a desirable flow pattern rather than permitting material to be flung from the feeder, directly into the flowguide
- transition is especially important for high or variable speed feeders

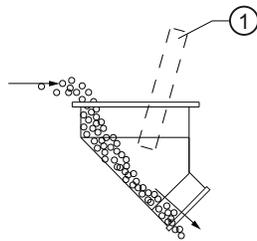

① baffle plate

- forward flowguide transition maintains the material in the same direction between the bin or feeder discharge and the flowmeter flowguide
- transition is acceptable for a low and constant velocity feeder
- if a forward flowguide transition must be used for a high or variable speed feeder application, install a baffle plate

Short fall chute

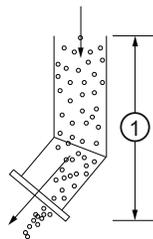

① < 0.6 m (2 ft)

- material in-feed chute where the bin or feeder discharge to flowmeter flowguide fall is less than 0.6 m (2 ft)
- material velocity due to gravity minimized
- chute centreline and angle should coincide with that of the flowguide, for a distance greater than or equal to the flowguide diameter (before the flowguide inlet)

Long fall chute

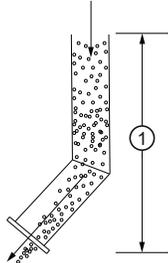

① > 0.6 m (2 ft)

- material in-feed where the bin or feeder discharge/flowguide fall is more than 0.6 m (2 ft)
- less desirable than the short fall chute because material velocity is greater, increasing flowmeter component abrasion
- greater distances after chute angle changes required to settle material into desirable flow patterns

Dogleg

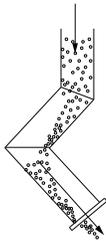

- used to reduce the detrimental effect of high or variable material velocity, especially when using a long fall chute
- for abrasive materials, line the chute with an abrasion resistant material, or use an in-feed deadbox

Deadbox



- installed where the chute angle changes. This will cause the material to impact upon itself, rather than the chute surface.
- used when the feeder discharge velocity is high, variable, where long fall chute angles change, and if the material is particularly abrasive

Pulsing feeder discharge damping

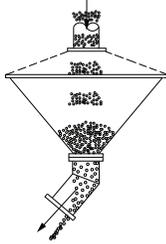

- install a temporary holding bin to receive pulsing material discharge from a feeder. Then the material is gravity fed from the bin to the flowmeter flowguide.
- provide manual or automatic control to ensure the holding bin is neither emptied nor overfilled while the feeder is in operation.
- bin could also be used for the integrator on-line calibration, (if so equipped). Refer to the integrator instruction manual for bin requirements.

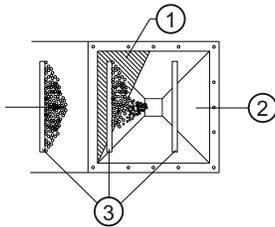

Top view

- ① baffle
- ② conveyor discharge
- ③ slats

- for drag conveyors, use a baffle plate installed at the conveyor discharge to reduce the heavy material pulsing associated with this type of feeder

In-feed/discharge air pressure

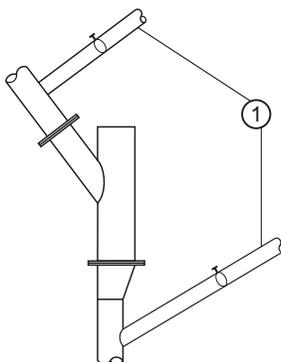

① to common dust collector

- Vent the in-feed and discharge chutes to a common dust collector if a material in-feed/discharge differential air pressure is anticipated and rotary airlock feeders are not used.
- A tuning gate can be installed in each vent to balance the air pressure.
- If a dust collector is not used, an air bypass chute can be installed between the flowmeter in-feed and discharge chutes.

In-feed/discharge air pressure

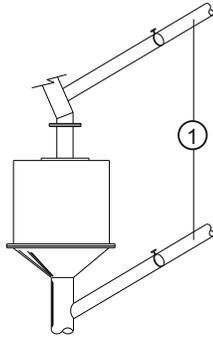

① to common dust collector

- when a material in-feed/discharge differential air pressure is anticipated, and rotary airlock feeders are not utilized, vent the in-feed and discharge chutes to a common dust collector
- install a tuning gate in each vent to balance the air pressure
- if a dust collector is not used, install an air bypass chute between the flowmeter in-feed and discharge chutes

8.4 Flowguide capacity

Flowguide capacity

Refer to the following chart, to ensure the flowguide capacity is suitable.

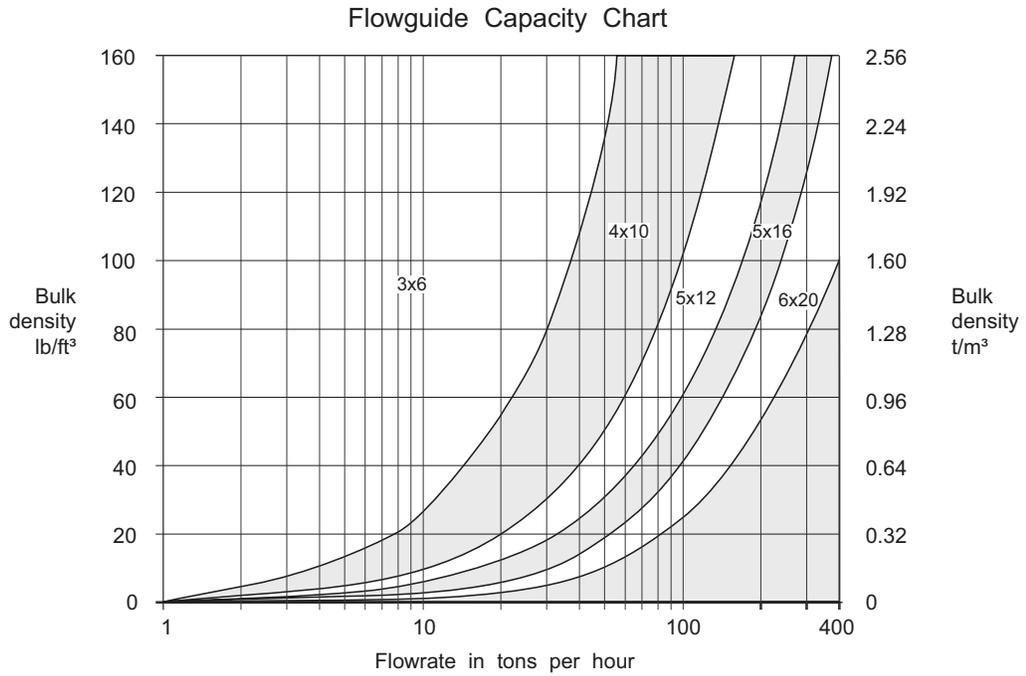

Note

If the material bulk density and flowrate is near a flowguide diameter upper limit, choose the next larger flowguide size.

For more information

www.siemens.com/level

www.siemens.com/weighing

Siemens AG
Industry Sector
1954 Technology Drive
P.O. Box 4225
Peterborough, ON
Canada K9J 7B1
email: techpubs.smpi@siemens.com

Subject to change without prior notice
7ML19985CU02 Rev. 2.0

© Siemens AG 2011



7 M L 1 9 9 8 5 C U 0 2

Printed in Canada

www.siemens.com/processautomation