

**MICREX-SX** *series*

**SPH**

**USER'S MANUAL**

**Digital High-Speed Input Module**

This User's Manual describes the system configuration, specifications and operations of MICREX-SX Series SPH Digital High-Speed Input Module (NP1X3206-A). Read this manual thoroughly and use this product correctly. Also read the related manuals listed below.

| Title  | Manual No. | Contents   |
|--|------------|--|
| User's Manual Instructions, MICREX-SX Series                         | FEH200     | Describes the MICREX-SX Series memory, language, system definitions, etc.  |
| User's Manual Hardware, MICREX-SX Series SPH                         | FEH201     | Describes the MICREX-SX Series system configuration and hardware specifications and handling of modules.             |
| User's Manual Digital High-Speed Output Module, MICREX-SX Series SPH | FEH212     | Describes the specifications and operations of MICREX-SX Series Pulse Output Module used for simplified positioning. |
| User's Manual D300winV2 <Reference>, MICREX-SX Series                | FEH254     | Describes the menus, icons and detailed operations of D300winV2.   |
| User's Manual D300winV3 <Reference>, MICREX-SX Series                | FEH257     | Describes the menus, icons and detailed operations of D300winV3.   |

In addition to the above manuals, the following Fuji Electric FA Components & Systems Co., Ltd. site offers various manuals and technical documents associated with MICREX-SX.  
URL <http://www.fujielectric.co.jp/fcs/eng/>

## Notes

1. This manual may not be transcribed or reproduced in whole or part without permission.
2. The contents of this manual including the specifications are subject to change without prior notice.
3. This manual has been prepared with extreme care; however, if you find any ambiguous or incorrect description in this manual, please contact us at one of the addresses listed at the end of this manual. At this time, inform us of the manual No. given on the cover page.

# Safety Precautions

Thoroughly read “Safety Precautions” before using this product.

In this manual, safety precautions are classified into “Warning” and “Caution” levels.

 **Warning** : Incorrect handling of the device may result in death or serious injury.

 **Caution** : Incorrect handling of the device may result in minor injury and/or property damage.

Some items indicated as  **Caution** may also result in a serious accident.

Because the safety instructions in any level give important information, be sure to strictly observe them. Specially important items are given below; they are also indicated in the manual text along with the symbols above.

## **Warning**

- ◇ While the power is supplied, do not touch energized parts such as terminals, or electric shock may occur.
- ◇ Before performing mounting, demounting, wiring, maintenance or inspection, be sure to set the power OFF, or electric shock, malfunction or fault may occur.
- ◇ Configure the emergency stop circuit, interlock circuit, etc. outside the PLC; otherwise, fault in PLC may cause damage to the machine or accident.
- ◇ Do not connect in wrong directions, charge, disassemble, deform, throw in fire, or short-circuit the batteries. Doing so may cause bursting or fire.
- ◇ Do not use batteries with deformation, leakage or other abnormalities, or bursting or fire may occur.
- ◇ Never open the FG terminal with LG-FG short-circuited, or electric shock may occur. (Be sure to ground that terminal.)

# Safety Precautions

## Caution

- ◇ If damage or deformation is found on the product when unpacking, do not use it, or fault or malfunction may occur.
- ◇ Do not give a shock to the product by dropping or falling it, or damage to the product or malfunction may occur.
- ◇ Install the product based on the instructions given in the instructions and other manuals. Inappropriate installation may cause the product to fall, malfunction or become faulty.
- ◇ Use the product under the rated voltage and current specified in the instructions and other manuals. Using the product under conditions outside the ratings may cause fire, malfunction or fault.
- ◇ Use (store) the product under the environmental conditions specified in the instructions and other manuals. Using (storing) the product under high temperature or humidity or in environment containing dust, corrosive gas, oil, organic solvent, vibrations with specially large amplitude, or shock may cause electric shock, fire, malfunction or fault when the product is used.
- ◇ Select electric cables suitable for voltages and currents applied and secure them with the specified torque. Inappropriate wiring or securing may cause fire, product falling, malfunction, or fault.
- ◇ When making application, take care not to put dust, cable fragments or iron powder into the device, or fire, accident, malfunction or fault may occur.
- ◇ After wiring has completed, be sure to remove dust cover paper from modules and units before starting operation. Operating the product with dust cover paper placed will cause fire, accident, malfunction or fault.
- ◇ Be sure to ground the ground terminals, or electric shock, malfunction or fault may occur.
- ◇ Periodically check that terminal and set screws are securely tightened. Using the product with these screws loosened may cause fire or malfunction.
- ◇ Be sure to place the attached connector cover on a connector unused, or malfunction or fault may occur.
- ◇ When performing program change or forced output during operation or starting or stopping operation, make sure of safety. Operation errors may cause damages to the machine or accidents.
- ◇ Insert the loader connector in the correct direction, or fault or malfunction may occur.
- ◇ Before touching the PLC, discharge static electricity charged on your body by touching grounded metal parts, etc. Excessive static electricity may cause malfunction or fault.
- ◇ Perform wiring correctly based on the instructions or other manuals. Wrong wiring may cause fire, accident or fault.
- ◇ When disconnecting the plug from a convenience outlet, do not hold the cord. Cut cables may cause malfunction or fault.
- ◇ Do not perform system change (I/O module mounting or dismounting) with the power supplied. Doing so may cause malfunction or fault.
- ◇ Never try to repair this product in the field. When necessary, request us for repair. Battery changes must be performed taking care of connector connections, etc., or fire, accident or fault may occur.
- ◇ When cleaning the product, set the power OFF and use towel moistened with warm water. Use of thinner or other organic solvent causes the device surface to be swollen or discolored.
- ◇ Do not remodel or disassemble this product, or fault may occur.
- ◇ When discarding this product, handle it as industrial waste.
- ◇ The product described in this manual has not been designed for the purpose of being used for devices or systems involved with human lives.
- ◇ When you are studying about using the product described in this manual for nuclear control, aerospace field, medical services, transportation equipment or passenger mobile bodies or for specific applications for such systems, please contact one of our sales offices.
- ◇ When applying the product described in this manual to such facilities that are assumed to be involved with human lives or cause occurrence of serious loss by faults of the product, be sure to install safety devices.
- ◇ The external power supply (24 VDC, etc.) connected to DC I/O terminals must be in the state of reinforced insulation from AC power supply, or accident or fault may occur. (Use of power supply compliant with EN60950 is recommended.)

# Revisions

\* Manual No. is shown on the cover.

| Printed on | * Manual No. | Revision contents                     |
|------------|--------------|---------------------------------------|
| Mar. 2004  | FEH211       | First edition printed.                |
| Aug. 2007  | FEH211a      | Clause 5-2-2, wiring diagram revised. |

Preface

Safety Precautions

Revision

Contents

Page

**Section 1 Overview ..... 1-1**

**Section 2 Specifications ..... 2-1**

2-1 General Specifications ..... 2-1

2-2 Input Specifications ..... 2-2

2-3 Pulse Catch Function ..... 2-3

2-3-1 Pulse catch operation ..... 2-3

2-3-2 Pulse catch reset ..... 2-4

2-4 Names and Functions of Parts ..... 2-5

2-4-1 Names of parts ..... 2-5

2-4-2 Functions of parts ..... 2-5

2-5 Outside Dimensions ..... 2-7

**Section 3 System Configuration ..... 3-1**

3-1 Mounting to Base Board ..... 3-1

3-1-1 Mounting locations ..... 3-1

3-1-2 Number of modules mounted ..... 3-1

**Section 4 Software Interface ..... 4-1**

4-1 Memory Assignments ..... 4-1

**Section 5 Wiring ..... 5-1**

5-1 Precautions for Wiring Work ..... 5-1

5-2 External Connections ..... 5-2

5-2-1 External input signal interface ..... 5-3

5-2-2 Sample connection of high-speed input module ..... 5-4

**Section 6 High-Speed Input Counter Expansion FB ..... 6-1**

6-1 Overview of Counter Expansion FB ..... 6-1

6-2 Sample Applications of Counter Expansion FB ..... 6-2

6-3 Counter Expansion FB Functions ..... 6-4

6-3-1 Ring operation count range ..... 6-4

6-3-2 Count operation mode ..... 6-5

6-4 Details of Counter Expansion FB ..... 6-6

6-5 Memory Size of High-Speed Input Counter Expansion FB ..... 6-10

6-6 Settings for Ring and Gate Operations ..... 6-10

---

## **Section 1 Overview**

---

# Section 1 Overview

Digital High-Speed Input Module NP1X3206-A is mounted on the MICREX-SX Series base board (connected to the SX bus) for 32-point input or 32-point pulse catch input.

The digital high-speed input module has a pulse counter input function, allowing to select up to four channels (two phases) of input signals of up to 20 kHz.

## 1) Image of fetching signal with pulse catch function

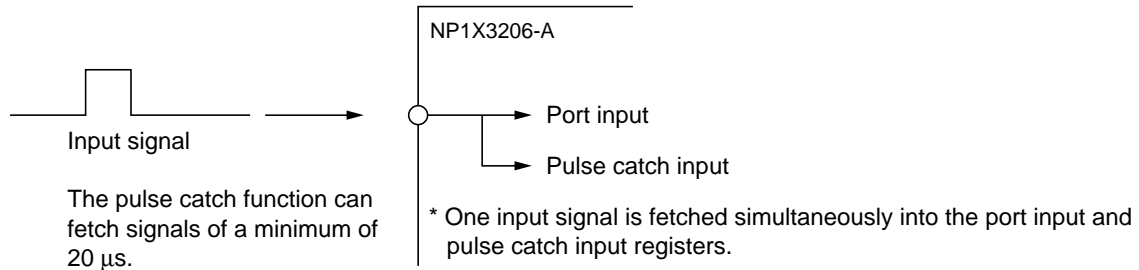

Note: Eight points of ports 1 to 8 can fetch pulse signals of a minimum of 20 μs.

Twenty-four points of ports 9 to 32 can fetch pulse signals of a minimum of 100 μs.

## 2) Image of fetching signal with pulse counter function

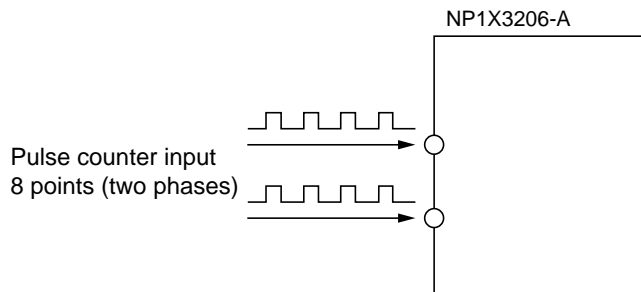

Note: When the pulse counter input function is used, the soft filter is unavailable.



---

## Section 2 Specifications

---

|   | Page       |
|---|------------|
| <b>2-1 General Specifications .....</b>       | <b>2-1</b> |
| <b>2-2 Input Specifications .....</b>         | <b>2-2</b> |
| <b>2-3 Pulse Catch Function .....</b>         | <b>2-3</b> |
| 2-3-1 Pulse catch operation .....             | 2-3        |
| 2-3-2 Pulse catch reset .....                 | 2-4        |
| <b>2-4 Names and Functions of Parts .....</b> | <b>2-5</b> |
| 2-4-1 Names of parts .....                    | 2-5        |
| 2-4-2 Functions of parts .....                | 2-5        |
| <b>2-5 Outside Dimensions .....</b>           | <b>2-7</b> |

| Items                           |                                    | Specifications  |
|---------------------------------|------------------------------------|---|
| Physical environment conditions | Operating ambient temperature      | 0 to 55° C  |
|                                 | Storage temperature                | -25 to +70° C   |
|                                 | Relative humidity                  | 20 to 95% (No condensation allowed.)  |
|                                 | Degree of pollution                | 2   |
|                                 | Anticorrosiveness                  | No corrosive gas allowed.   |
|                                 | Possible altitud                   | Altitude 2000 m or less (Atmospheric pressure during transportation 70 kPa or more)                                 |
| Mechanical operating conditions | Vibration resistance               | Single amplitude: 0.15 mm, Constant acceleration: 19.6 m/s <sup>2</sup>   |
|                                 | Shock resistance                   | Peak acceleration: 147 m/s <sup>2</sup>   |
| Electrical operating conditions | Noise immunity                     | Noise simulation method, risetime 1 ns, pulse width 1 μs, 1.5 kV  |
|                                 | Electrostatic discharge resistance | Contact discharging method: ±6 kV, Aerial discharging method: ±8  |
|                                 | Radiation field resistance         | 10 V/m (80 MHz to 1000 MHz)   |
| Structure                       |                                    | Incorporated in board, IP30   |
| Cooling type                    |                                    | Natural cooling   |
| Insulation type                 |                                    | Photocoupler insulation   |
| Dielectric strength             |                                    | 1500 VAC for one minute between all external terminals and ground terminal  |
| Insulation resistance           |                                    | 10MΩ or more between all external terminals and ground terminal, measured with 500 VDC insulation resistance tester |
| Internal power consumption      |                                    | 24 VDC, 50 mA or less (with all points ON)  |
| Mass                            |                                    | Approximately 130 g   |
| Outside dimensions              |                                    | See Section 2-5.  |

## 2-2 Input Specifications

| Items                        |                                | Specifications   |  |
|------------------------------|--------------------------------|--|--|
| Number of input points       |                                | 32 points (32 points/common circuit)   |  |
| Input signal conditions      | Rated voltage                  | 24 VDC   |  |
|                              | Maximum allowable voltage      | 30 VDC   |  |
|                              | Allowable ripple ratio         | 5% or less   |  |
| Input circuit characteristic | Input type                     | Source input   |  |
|                              | Rated current                  | 4 mA (for 24 VDC)  |  |
|                              | Input impedance                | 5.6 kΩ   |  |
|                              | Standard operation range       | OFF → ON   | 15 to 30 V   |
|                              |                                | ON → OFF   | 0 to 5 V   |
|                              | Input delay time               | OFF → ON   | Changeable at a time by parameter setting, (OFF → ON) – (ON → OFF)<br>0.1 – 0.1 ms, 1 – 1 ms, 3 – 3 ms, 3 – 10 ms, 10 – 10 ms, 30 – 30 ms,<br>100 – 100 ms, no soft filter (See Note.) |
| ON → OFF                     |                                |  |  |
| Input type                   |                                | DC type 1  |  |
| Other functions              |                                | Pulse catch function for 32 points,<br>Minimum pulse width 20 μs for ports 1 to 8, 100 μs for ports 9 to 32  |  |
| Connection                   | External connectio             | One 40-pole connector (FCN-365P040-AU)   |  |
|                              | Applicable electric cable size | AWG #23 or less (When soldered connector used)   |  |
| Input signal display         |                                | Display selected for each of 16 points by switch<br>Green LED lit for each point ON, Logical side<br>ONL: Lit when normal (green LED), ERR: Abnormal (red LED) |  |
| Derating conditions          |                                | Ratio of simultaneous ON: Maximum 100% (for 26.4 VDC, 55°C)<br>Ratio of simultaneous ON: Maximum 75% (for 30 VDC, 55°C)  |  |
| Number of occupied words     |                                | 14 words (Input: 9 words, Output: 5 words)   |  |
| Number of occupied slots     |                                | 1 slot   |  |

Note: When the pulse counter input function is used, the soft filter is unavailable.

### 2-3-1 Pulse catch operation

When a pulse (minimum width 20  $\mu\text{s}$ ) is input to the signal input terminal of the digital high-speed input module, "1" is set in the corresponding bit in the pulse catch register of the high-speed input module. Information of the pulse catch register is fetched to the pulse catch flag assigned to the I/O area in the CPU module through the SX bus. Once the pulse catch register in the high-speed input module is set, it remains set until it is reset by a pulse catch reset flag.

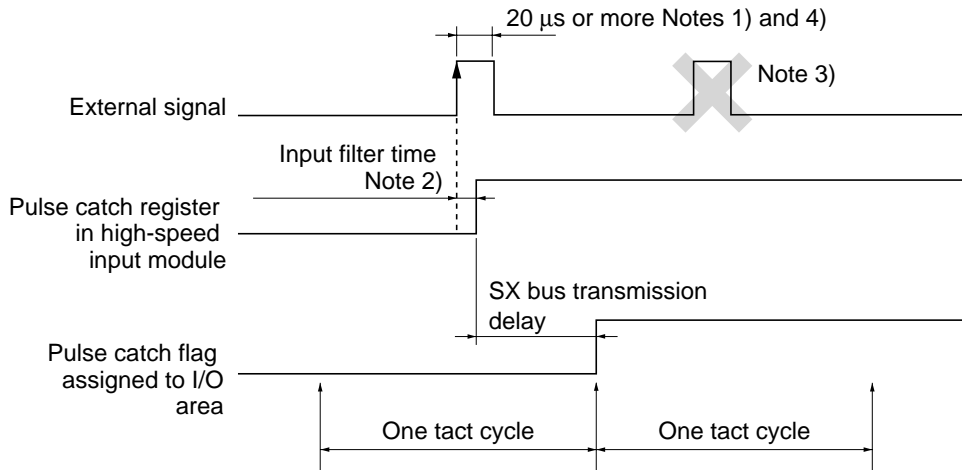

#### Notes:

- 1) The width of a pulse that can be fetched is the set digital input filter time +20  $\mu\text{s}$ . Therefore, when "none" is specified as the input filter time, the minimum width of a pulse that can be fetched becomes 20  $\mu\text{s}$ .
- 2) A delay of the set input filter time occurs. The input filter time that can be set in this module is 0.1 – 0.1 ms, 1 – 1 ms, 3 – 3 ms, 3 – 10 ms, 10 – 10 ms, 30 – 30 ms, 100 – 100 ms for (OFF  $\rightarrow$  ON) – (ON  $\rightarrow$  OFF).
- 3) When the corresponding bit in the pulse catch register of the high-speed input module is "1," a pulse input to the signal input terminal cannot be fetched. Using the pulse catch data reset flag, reset the pulse catch register in the high-speed input module.
- 4) Only ports 1 to 8 can be used to fetch a pulse of 20  $\mu\text{s}$ . The minimum pulse width for other ports is 100  $\mu\text{s}$ .

### 2-3-2 Pulse catch reset

After fetching a pulse catch signal with an application program, reset the pulse catch information. By setting ON the pulse catch data reset flag assigned to the I/O area (Q area), the pulse catch register in the high-speed input module is reset and the pulse catch flag assigned to the I/O area goes OFF.

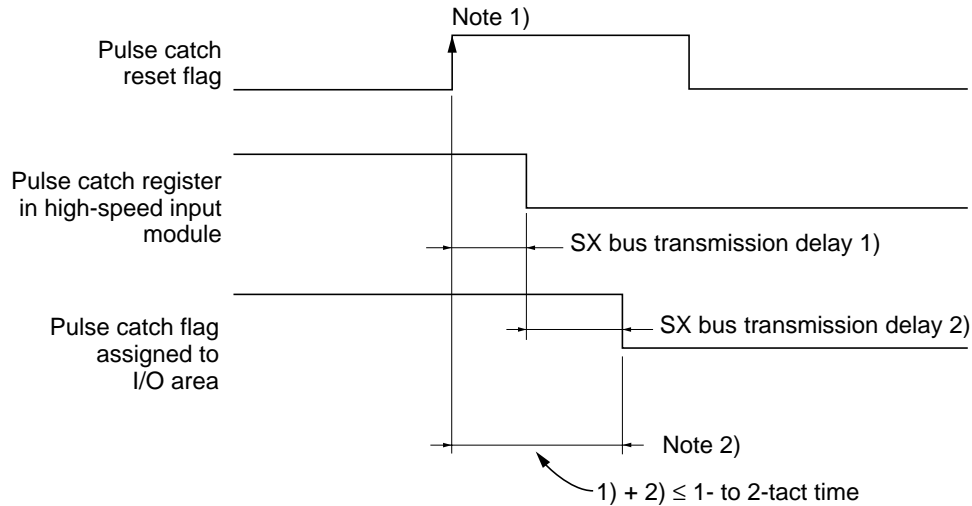

**Notes:**

- 1) The pulse catch register is reset at the rising edge of the pulse catch data reset flag. Therefore, when resetting the pulse catch register again, the reset flag must be once set OFF.
- 2) After issuing a pulse catch data reset command from an application program, it takes 1- to 2-tact time before the pulse catch flag assigned to the I/O area goes OFF (when the task can be executed at every scan in synchronization with the tact time).

## 2-4 Names and Functions of Parts

### 2-4-1 Names of parts

1) Status display LEDs

2) LED display selection switch

3) Input connector slot

4) Specification name plate

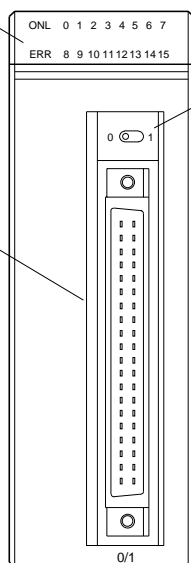

### 2-4-2 Functions of parts

#### 1) Status display LEDs

Indicate the states of NP1X3206-A operation and input signals.

|     |   |   |    |    |    |    |    |    |
|-----|---|---|----|----|----|----|----|----|
| ONL | 0 | 1 | 2  | 3  | 4  | 5  | 6  | 7  |
| ERR | 8 | 9 | 10 | 11 | 12 | 13 | 14 | 15 |

| Symbols | LED colors | ON conditions   |
|---------|------------|---|
| ONL     | Green      | Remains ON during normal operation  |
| ERR     | Red        | Goes ON when this module or SX bus has an error.  |
| 0 to 15 | Green      | Goes ON when the input signal is ON.<br>Note: When the ON-period of the input signal is very short, it may be invisible to the naked eye. |

#### 2) LED display selection switch

Used to select the address of the input signal to be displayed.

- 0  1
- When the switch is on the left side, input signals to the first 16 points (%IX□.1.0 to %IX□.1.15) are displayed.
  - When the switch is on the right side, input signals to the last 16 points (%IX□.2.0 to %IX□.2.15) are displayed.

## 2-4 Names and Functions of Parts

### 3) Input connector slot

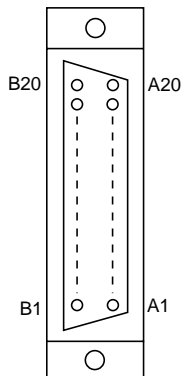

<Signal assignments>

|                                |        |     |         |        |
|--------------------------------|--------|-----|---------|--------|
| Port 9                         | B20    | A20 | Port 21 |        |
| Port 10                        | B19    | A19 | Port 22 |        |
| Port 11                        | B18    | A18 | Port 23 |        |
| Port 12                        | B17    | A17 | Port 24 |        |
| Port 13                        | B16    | A16 | Port 25 |        |
| Port 14                        | B15    | A15 | Port 26 |        |
| Port 15                        | B14    | A14 | Port 27 |        |
| Port 16                        | B13    | A13 | Port 28 |        |
| Port 17                        | B12    | A12 | Port 29 |        |
| Port 18                        | B11    | A11 | Port 30 |        |
| Port 19                        | B10    | A10 | Port 31 |        |
| Port 20                        | B9     | A9  | Port 32 |        |
| C0                             | B8     | A8  | C0      |        |
| C0                             | B7     | A7  | C0      |        |
| CH1 for pulse counter function | Port 1 | B6  | A6      | Port 5 |
|                                | C0     | B5  | A5      | C0     |
|                                | Port 2 | B4  | A4      | Port 6 |
| CH2 for pulse counter function | Port 3 | B3  | A3      | Port 7 |
|                                | C0     | B2  | A2      | C0     |
|                                | Port 4 | B1  | A1      | Port 8 |
| CH3 for pulse counter function | Port 5 | A6  | Port 1  |        |
|                                | C0     | A5  | C0      |        |
|                                | Port 6 | A4  | Port 2  |        |
| CH4 for pulse counter function | Port 7 | A3  | Port 3  |        |
|                                | C0     | A2  | C0      |        |
|                                | Port 8 | A1  | Port 4  |        |

Note: C0 is internally connected.

### 4) Specification name plate

The name plate placed on the right side of the module shows the manufacture date and serial number.

# 2-5 Outside Dimensions

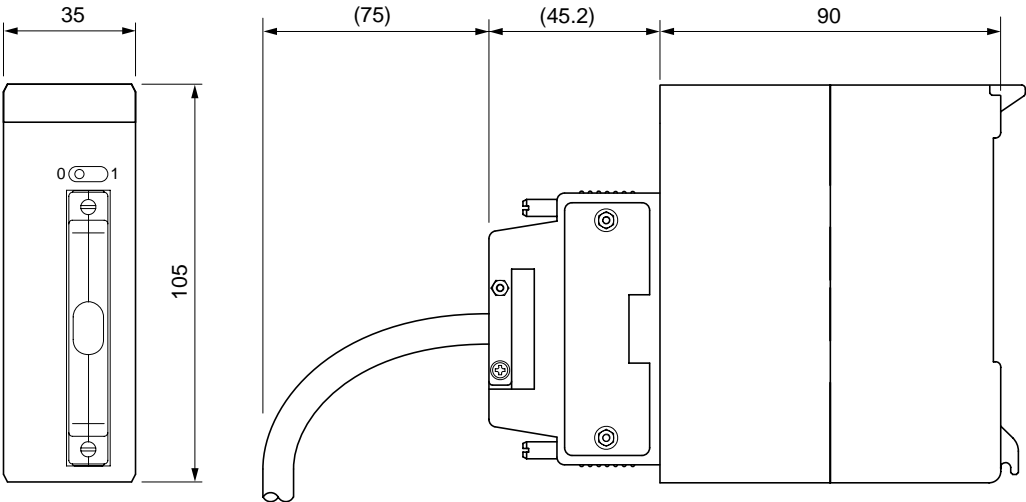



---

## Section 3 System Configuration

---

|   | Page       |
|---|------------|
| <b>3-1 Mounting to Base Board .....</b> | <b>3-1</b> |
| 3-1-1 Mounting locations .....          | 3-1        |
| 3-1-2 Number of modules mounted .....   | 3-1        |

# Section 3 System Configuration

## 3-1 Mounting to Base Board

### 3-1-1 Mounting locations

The digital high-speed input module is an input module connected to the SPH SX bus. The mounting locations on the base board are as shown below.

Any locations except the power module mounting slots (two slots at the base board left end) are available.

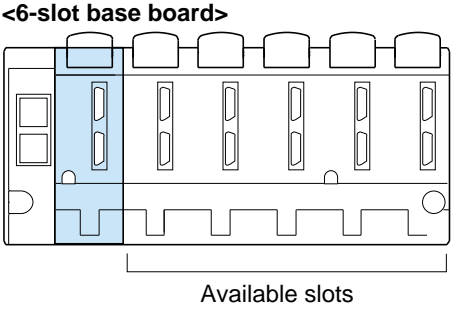
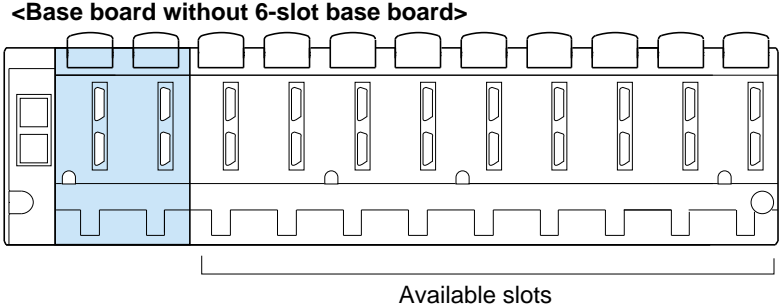

Note: Base boards of substations such as T-link or JPCN-1 are unavailable.

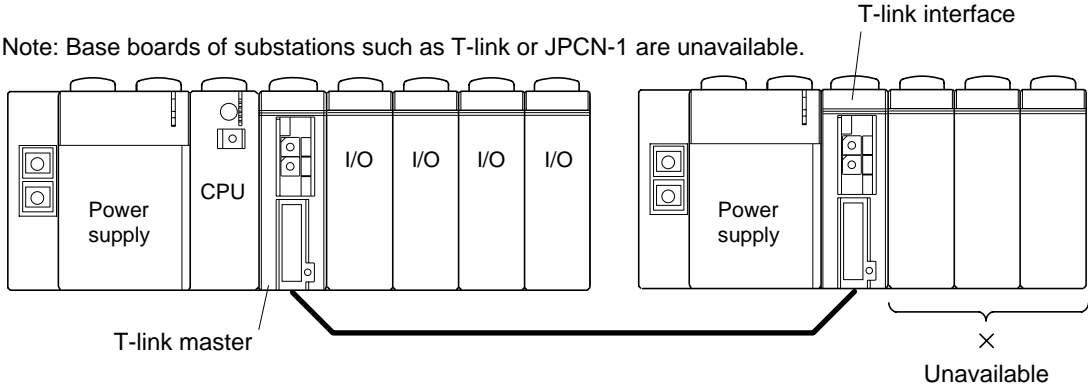

### 3-1-2 Number of modules mounted

A maximum of 238 modules can be connected to the SX bus and a maximum of 254 modules can be connected in one configuration including the links of the I/O master (restriction by hardware).

Note that the number of modules that can be connected is limited according to the number of words in the I/O areas (I and Q areas) occupied by these modules.

$$\frac{512 \text{ words}}{14 \text{ words}} \doteq 36.5 \Rightarrow 36 \text{ modules}$$

---

## Section 4 Software Interface

---

|   | Page       |
|---|------------|
| <b>4-1 Memory Assignments .....</b>   | <b>4-1</b> |
| (1) Input signal registers (offset addresses +1, +2) .....                  | 4-2        |
| (2) Pulse catch flags (offset addresses +3, +4) .....                       | 4-2        |
| (3) Pulse catch data reset flags (offset addresses +10, +11) .....          | 4-2        |
| (4) Pulse catch enable edge set registers (offset addresses +12, +13) ..... | 4-3        |
| (5) Pulse count register (Offset address +0) .....                          | 4-4        |
| (6) Pulse count data registers (Offset addresses +5, +6, +7, +8) .....      | 4-6        |
| (7) Pulse count register (Offset address +9) .....                          | 4-6        |

# Section 4 Software Interface

## 4-1 Memory Assignments

The digital high-speed input module occupies an I/O area of 14 words (9 input words and 5 output words).

| Offset address | b15                                    | b0 |  |
|----------------|--|----|--|
| +0             | Pulse count register                   |    | } High-speed input module →<br>CPU (9 words) |
| +1             | Input register 1                       |    |  |
| +2             | Input register 2                       |    |  |
| +3             | Pulse catch register 1                 |    |  |
| +4             | Pulse catch register 2                 |    |  |
| +5             | Pulse count data register 1            |    |  |
| +6             | Pulse count data register 2            |    |  |
| +7             | Pulse count data register 3            |    |  |
| +8             | Pulse count data register 4            |    |  |
| +9             | Pulse count register                   |    | } CPU →<br>high-speed input module (5 words) |
| +10            | Pulse catch register 1                 |    |  |
| +11            | Pulse catch register 2                 |    |  |
| +12            | Pulse catch enable edge set register 1 |    |  |
| +13            | Pulse catch enable edge set register 2 |    |  |

# 4-1 Memory Assignments

## (1) Input signal registers (offset addresses +1, +2)

Store the ON/OFF states of the signal input to the input signal pin (1: ON, 0: OFF).

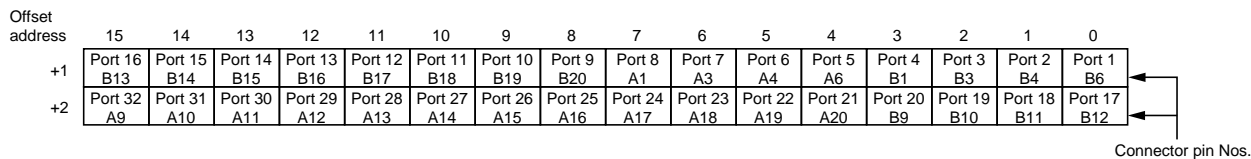

For example, the ON/OFF information of the signal input to port 8 (connector No. A1) is stored in the 7th bit at offset address +1. When the module SX bus station No. is "1," the input signal address for port 8 in the application program becomes "%IX1.1.7."

## (2) Pulse catch flags (offset addresses +3, +4)

At the rising or falling edge of the signal input to the input signal pin, "1" is set in the corresponding bit. The set pulse catch information is reset by the pulse catch data reset flag.

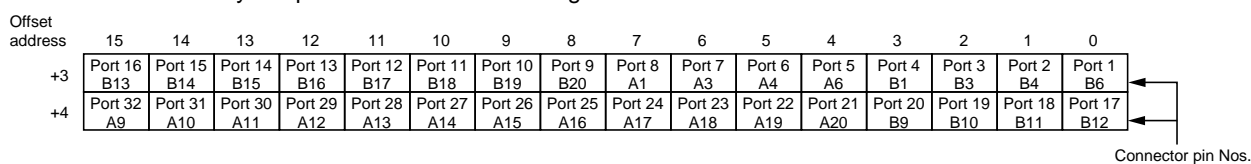

For example, the pulse catch data of the signal input to port 8 (connector No. A1) is stored in the 7th bit at offset address +3. When the module SX bus station number is "1," the input signal address for port 8 in the application program becomes "%IX1.3.7."

## (3) Pulse catch data reset flags (offset addresses +10, +11)

Reset the data set in the pulse catch register. At the rising edge of the corresponding bit in this register, the pulse catch data corresponding to that bit is reset.

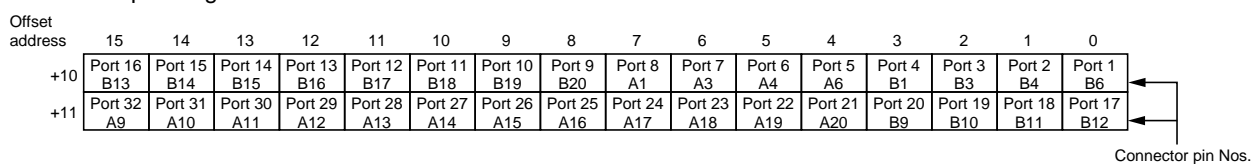

For example, when resetting the pulse catch data of the signal input to port 8 (connector No. A1), the 7th bit at offset address +10 is set ON. When the module SX bus station No. is "1," "%QX1.10.7" is set ON.

Note: The pulse catch data is reset at the rising edge of this flag.

## (4) Pulse catch enable edge set registers (offset addresses +12, +13)

These registers are used to set the rising edge or falling edge of the input signal as the pulse catch timing.

1: Rising edge, 0: Falling edge

| Offset address | 15             | 14             | 13             | 12             | 11             | 10             | 9              | 8              | 7              | 6              | 5              | 4              | 3             | 2              | 1              | 0              |
|----------------|----------------|----------------|----------------|----------------|----------------|----------------|----------------|----------------|----------------|----------------|----------------|----------------|---------------|----------------|----------------|----------------|
| +12            | Port 16<br>B13 | Port 15<br>B14 | Port 14<br>B15 | Port 13<br>B16 | Port 12<br>B17 | Port 11<br>B18 | Port 10<br>B19 | Port 9<br>B20  | Port 8<br>A1   | Port 7<br>A3   | Port 6<br>A4   | Port 5<br>A6   | Port 4<br>B1  | Port 3<br>B3   | Port 2<br>B4   | Port 1<br>B6   |
| +13            | Port 32<br>A9  | Port 31<br>A10 | Port 30<br>A11 | Port 29<br>A12 | Port 28<br>A13 | Port 27<br>A14 | Port 26<br>A15 | Port 25<br>A16 | Port 24<br>A17 | Port 23<br>A18 | Port 22<br>A19 | Port 21<br>A20 | Port 20<br>B9 | Port 19<br>B10 | Port 18<br>B11 | Port 17<br>B12 |

Connector pin Nos.

### Notes

#### 1) Precautions for using pulse catch input (applicable to versions before 20)

- When the power is set ON, activating the system or writing to the pulse catch enable edge set register, the pulse catch data goes ON. Therefore, clear the pulse catch data before using it.

- Sample program 1 (Clearing pulse catch data until the timing that requires pulse catch)

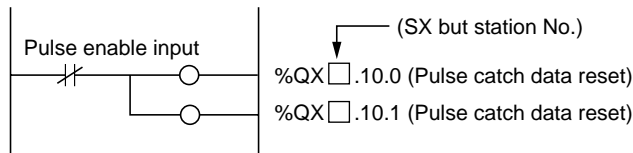

- Sample program 2 (Clearing pulse catch data at activation)

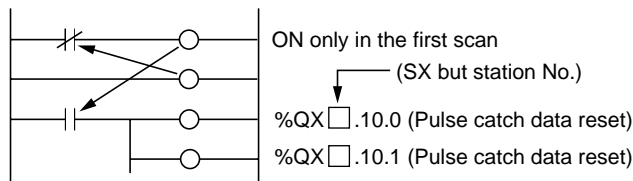

Normally, use pulse catch enable edge set register 1.  
The pulse can be fetched at the edge of the input given.

- Sample program 3 (Fetching pulse at input ON-edge)

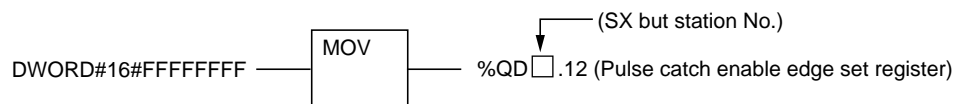

When fetching a pulse at input OFF-edge, data of the corresponding pulse catch enable edge set register should be "0."

- 0: Falling edge (default)

# 4-1 Memory Assignments

## (5) Pulse count register (Offset address +0)

- This register shows the status indication information signal when the high-speed input module is performing pulse count operation.

| CH No.      | CH3    |                    |                                |                        | CH2    |                    |                                |                        | CH1    |                    |                                |                        | CH0    |                    |                                |                        |
|-------------|--------|--------------------|--------------------------------|------------------------|--------|--------------------|--------------------------------|------------------------|--------|--------------------|--------------------------------|------------------------|--------|--------------------|--------------------------------|------------------------|
| Address No. | 15     | 14                 | 13                             | 12                     | 11     | 10                 | 9                              | 8                      | 7      | 6                  | 5                              | 4                      | 3      | 2                  | 1                              | 0                      |
| Signal name | Unused | Rotation direction | Current value clear completion | Count operation status | Unused | Rotation direction | Current value clear completion | Count operation status | Unused | Rotation direction | Current value clear completion | Count operation status | Unused | Rotation direction | Current value clear completion | Count operation status |

### Description of signals

#### 1) Signal name: Count operation status signal

Description

- Response signal for count enable command signal
- 0: Disabled, 1: Enabled

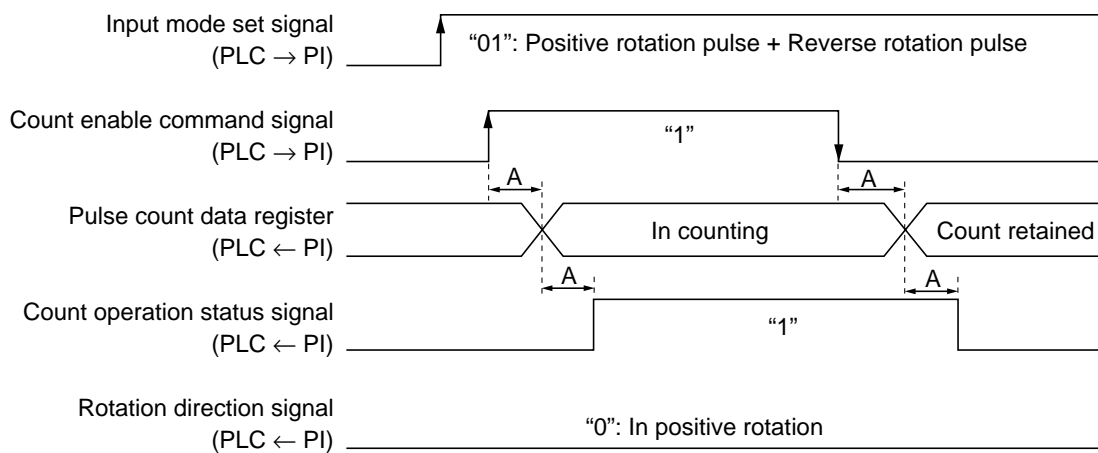

A: 1 to 2 tacts (The tact time varies depending on the program size and tact time setting.)

## 2) Signal name: Current value clear completion signal

Description

- Response signal for current value clear command signal
- 1: Current value clear completion

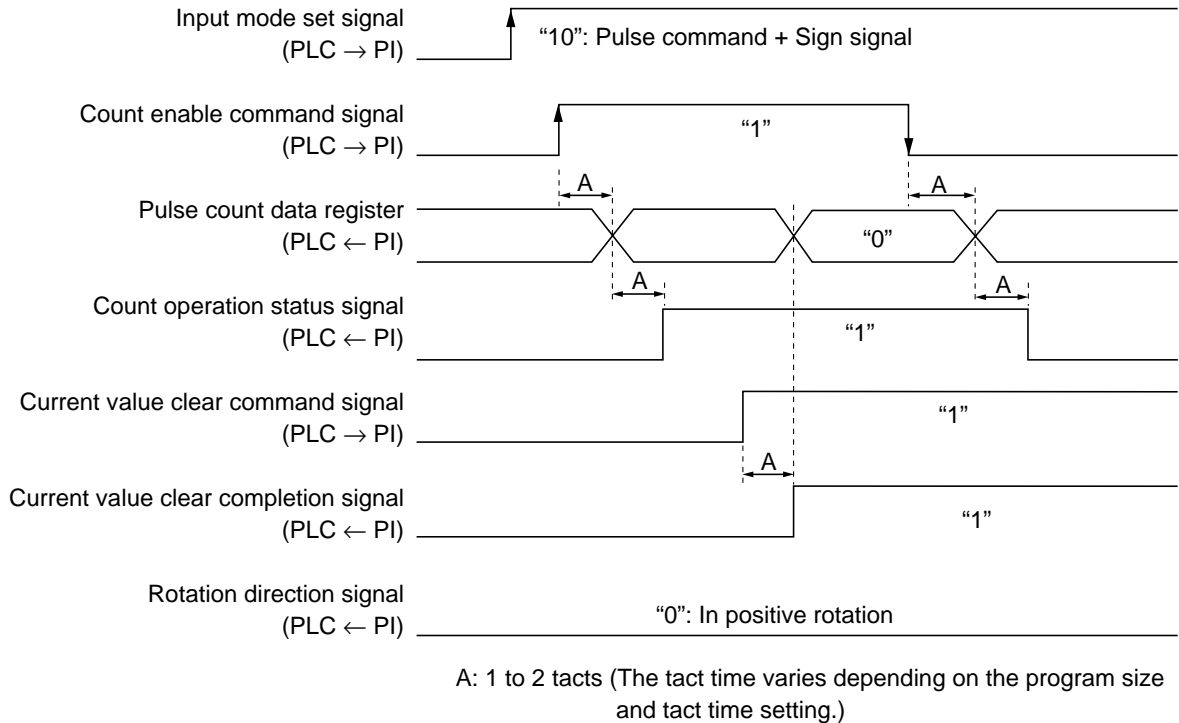

## 3) Signal name: Rotation direction signal

Description

- Indicates the status of the signal input to the high-speed input module.
- "0": In positive rotation, "1": In negative rotation

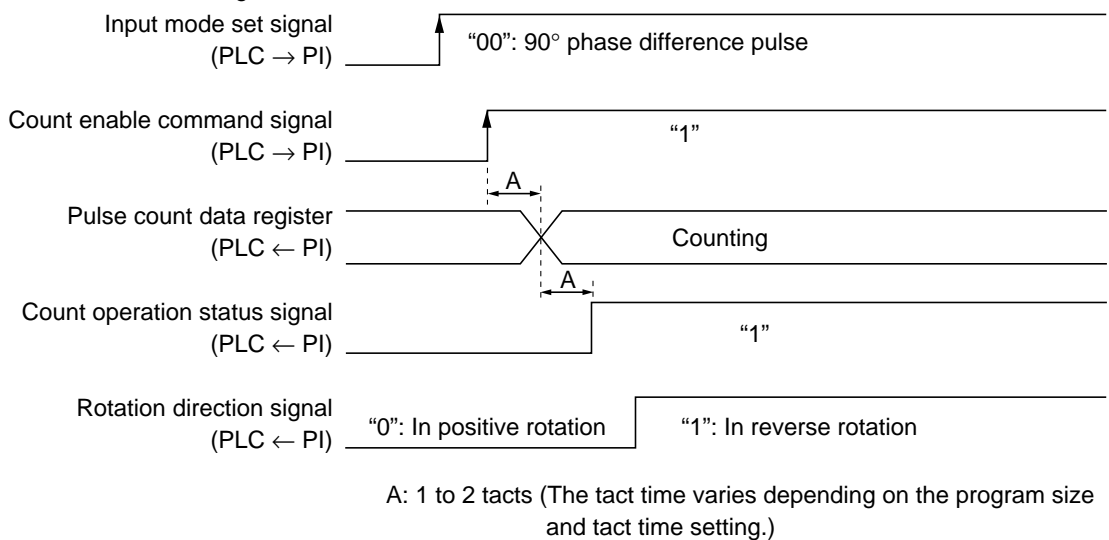



## 4-1 Memory Assignments

### (6) Pulse count data registers (Offset addresses +5, +6, +7, +8)

- These registers perform counting during counter input function operation by the high-speed input module.

| Address No. | 15 ←   | 0 |
|-------------|--|---|
| 5           | Pulse count data register (current value at channel 0) |   |
| 6           | Pulse count data register (current value at channel 1) |   |
| 7           | Pulse count data register (current value at channel 2) |   |
| 8           | Pulse count data register (current value at channel 3) |   |

- The data type is UINT.
- When the maximum value is exceeded during pulse counting, the count becomes "0" and when the value is less than "0," it goes to the maximum value.

### (7) Pulse count register (Offset address +9)

- This is a command signal for the high-speed input module.

| CH No.      | CH3                   |    |                                    |                             | CH2                   |    |                                    |                             | CH1                   |   |                                    |                             | CH0                   |   |                                    |                             |
|-------------|-----------------------|----|------------------------------------|-----------------------------|-----------------------|----|------------------------------------|-----------------------------|-----------------------|---|------------------------------------|-----------------------------|-----------------------|---|------------------------------------|-----------------------------|
| Address No. | 15                    | 14 | 13                                 | 12                          | 11                    | 10 | 9                                  | 8                           | 7                     | 6 | 5                                  | 4                           | 3                     | 2 | 1                                  | 0                           |
| Signal name | Input mode set signal |    | Current value clear command signal | Count enable command signal | Input mode set signal |    | Current value clear command signal | Count enable command signal | Input mode set signal |   | Current value clear command signal | Count enable command signal | Input mode set signal |   | Current value clear command signal | Count enable command signal |

### Description of signals

#### 1) Signal name: Count enable command signal

Description

- Count enable signal for the high-speed input module

"0": Disabled, "1": Enabled

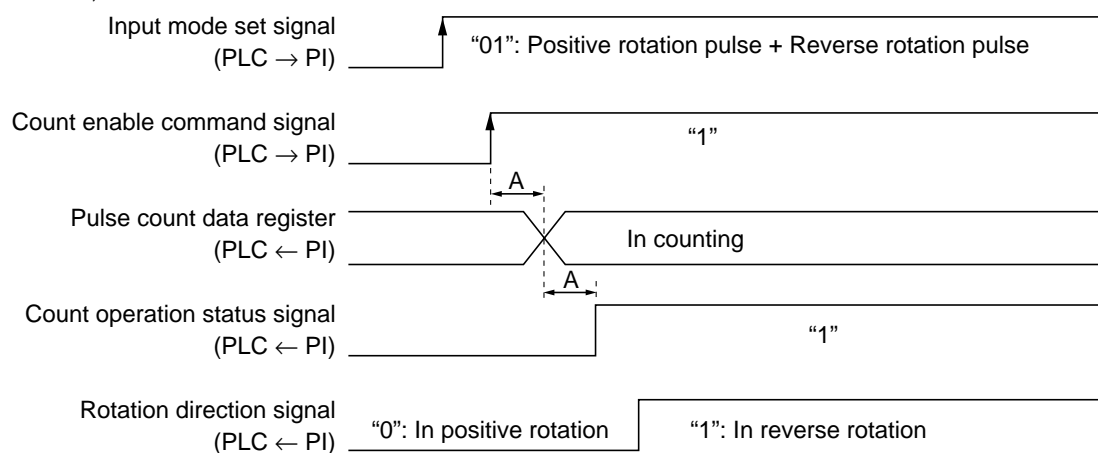

A: 1 to 2 tacts (The tact time varies depending on the program size and tact time setting.)

- The response signal for the count enable signal is the count operation status signal.
- When the count enable signal is "1," the external pulse signal is acceptable.  
When the count enable signal is "0," the external pulse signal is unacceptable.

## 2) Signal name: Current value clear command signal

Description

- Clears the pulse count data register area of the high-speed input module to "0."
- 1: Current value clear

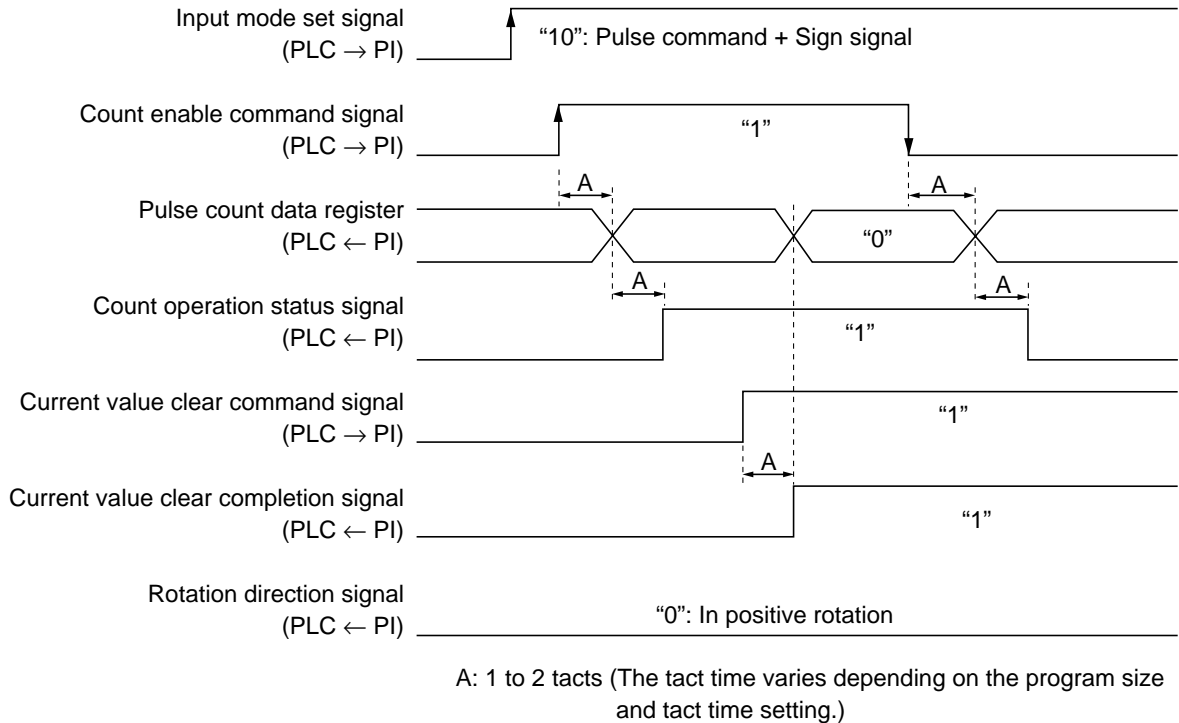

- The response signal for the current value clear command signal is the current value clear completion signal.
- The current value clear command signal can also be cleared during count operation.

## 3) Signal name: Input mode set signal

Description

- Set when performing counter operation by the high-speed input module.

### 3)-1 90° phase difference pulse

- Set address bits "2," "3," "6," "7," "10," "11," "14" and "15" to "0." The input specifications are given below.

90° phase difference pulse (A-/B-phases, 4-multiply, maximum 80 kHz, duty 50%)

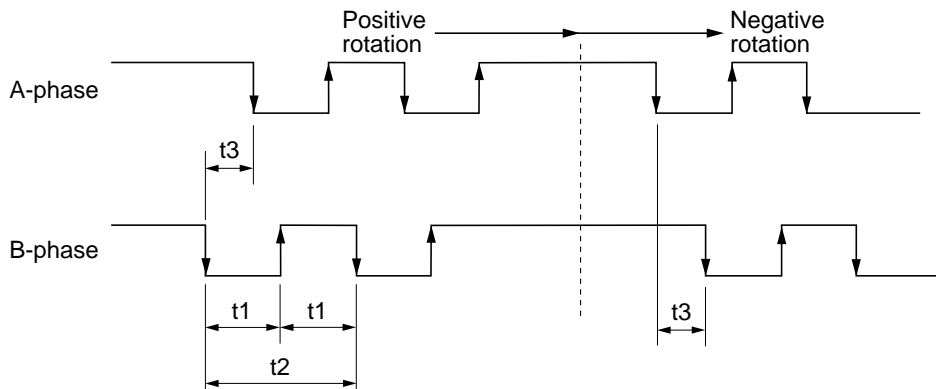

Minimum pulse width:  $t1 > 20 \mu\text{s}$ , Minimum pulse cycle:  $t2 > 40 \mu\text{s}$   
 Minimum edge interval:  $t3 > 20 \mu\text{s}$

## 4-1 Memory Assignments

### 3)-2 Positive rotation pulse + Negative rotation pulse

- Set address bits "2," "6," "10" and "14" to "1." The input specifications are given below.

Positive rotation pulse + Negative rotation pulse (maximum 20 kHz)

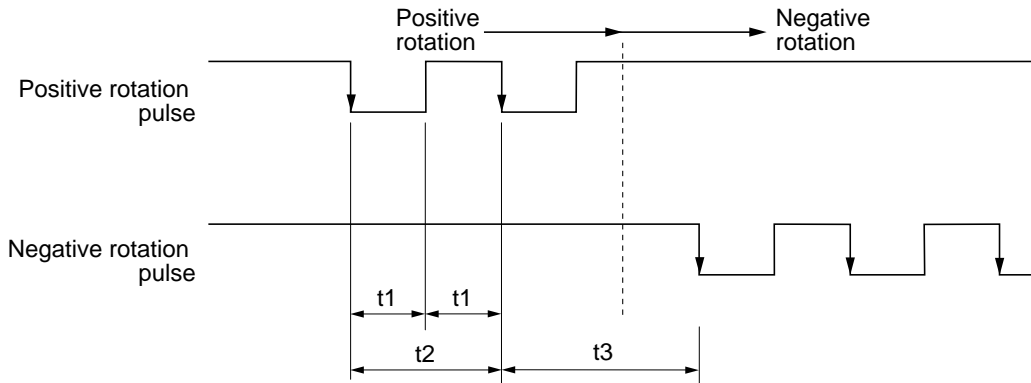

Minimum pulse width:  $t_1 > 20 \mu\text{s}$ , Minimum pulse cycle:  $t_2 > 40 \mu\text{s}$

Minimum edge interval:  $t_3 > 40 \mu\text{s}$

### 3)-3 Pulse command + Sign signal

- Set address bits "3," "7," "11" and "15" to "1." The input specifications are given below.

Pulse command + Sign signal (maximum 20 kHz)

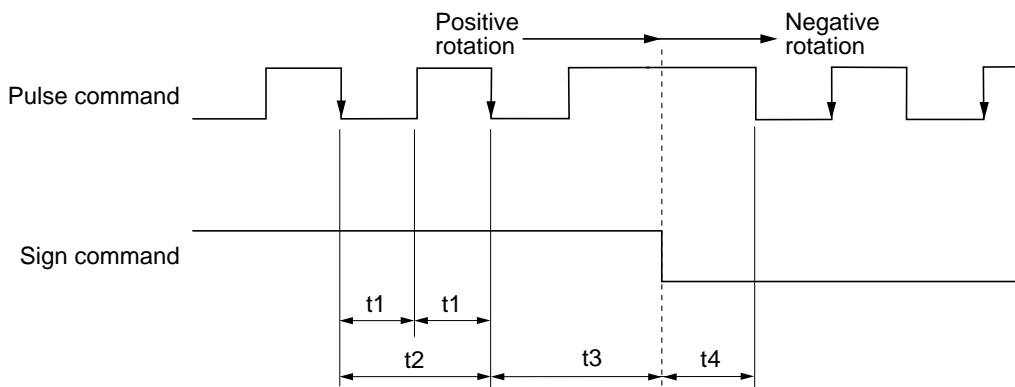

Minimum pulse width:  $t_1 > 20 \mu\text{s}$ , Minimum pulse cycle:  $t_2 > 40 \mu\text{s}$

Minimum edge interval:  $t_3 > 20 \mu\text{s}$  before sign switching,  $t_4 > 20 \mu\text{s}$  after sign switching

---

## Section 5 Wiring

---

|  |            |
|--|------------|
| <b>5-1 Precautions for Wiring Work .....</b>             | <b>5-1</b> |
| <b>5-2 External Connections .....</b>                    | <b>5-2</b> |
| 5-2-1 External input signal interface .....              | 5-3        |
| 5-2-2 Sample connection of high-speed input module ..... | 5-4        |

# Section 5 Wiring

## 5-1 Precautions for Wiring Work

- 1) Do not remove dust cover paper before wiring work completes.  
When the wiring work has completed, be sure to remove dust cover paper before starting operation.
- 2) Separate high-voltage and power lines from the module input signal lines and do not place these lines in parallel.
- 3) Use appropriate electric cables for wiring.  
Available connector and cable size are listed below.
- 4) When using the high-speed input module as a counter, use common sealed cables.

<Available connector and cable size>

Use the 40-pin connector given below manufactured by Fujitsu.

| Type     | Model (Manufactured by Fujitsu) |                                  | Cable size                                      |
|----------|---------------------------------|----------------------------------|---|
| Soldered | Socket<br>FCN-361J040-AU        | Connector cover<br>FCN-360C040-B | AWG23 or less<br>(0.26 mm <sup>2</sup> or less) |

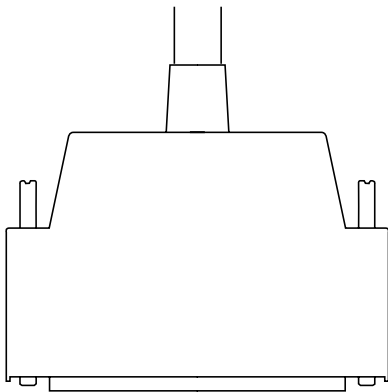

Soldered type (Note)

Note: As a soldered type connector, NP8V-CN (manufactured by Fuji Electric) is available.

# 5-2 External Connections

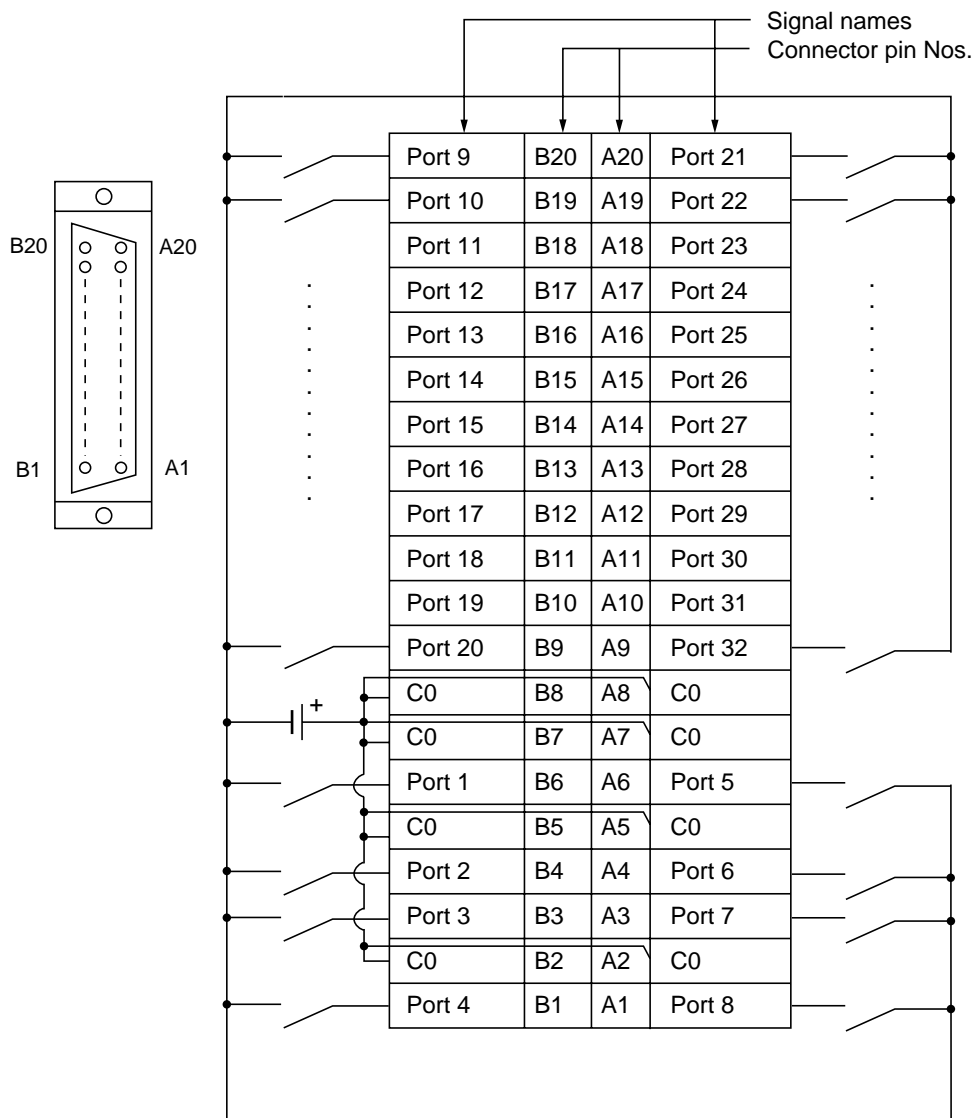

## 5-2-1 External input signal interface

| Signal name                    | Circuit drawing   |
|--------------------------------|---|
| High-speed input ports 1 to 8  | <p>The circuit drawing shows a common C0 line connected to eight high-speed input ports (Port 1, Port 2, ..., Port 8). Each port is connected to the C0 line through a 5.6 kΩ resistor. A 1.5 kΩ resistor and a capacitor are connected in parallel between the port and the C0 line. Each port also has a Schmitt trigger buffer connected to the C0 line.</p> |
| High-speed input ports 9 to 32 | <p>The circuit drawing shows a common C0 line connected to high-speed input ports (Port 9, Port 10, ..., Port 32). Each port is connected to the C0 line through a 5.6 kΩ resistor. A 1 kΩ resistor and a capacitor are connected in parallel between the port and the C0 line. Each port also has a Schmitt trigger buffer connected to the C0 line.</p>       |

## 5-2 External Connections

### 5-2-2 Sample connection of high-speed input module

Sample: Connecting OMRON encoder (Model: E6B2-CWZ6C)

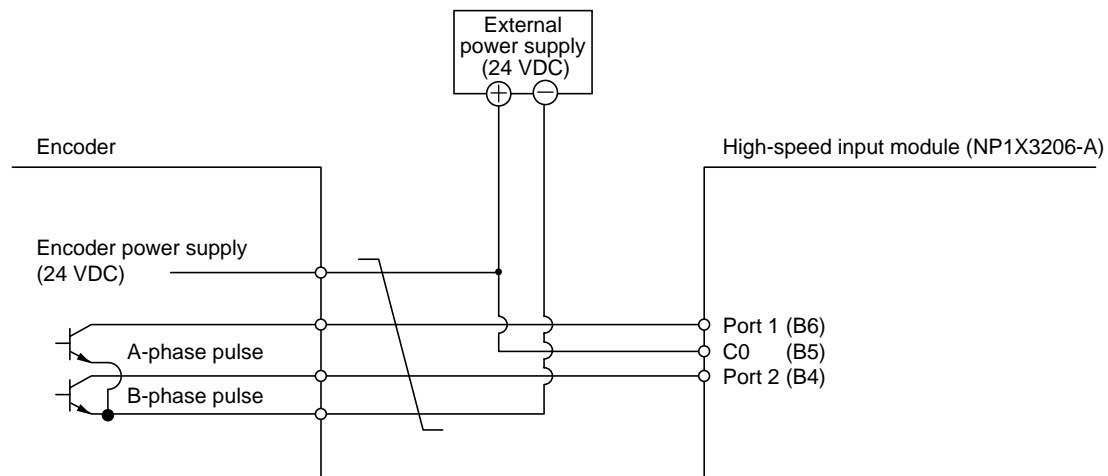

Note: When using the high-speed input module as a counter input, use common sealed cables.



---

## Section 6 High-Speed Input Counter Expansion FB

---

|   | Page        |
|---|-------------|
| <b>6-1 Overview of Counter Expansion FB .....</b>                                   | <b>6-1</b>  |
| <b>6-2 Sample Applications of Counter Expansion FB .....</b>                        | <b>6-2</b>  |
| (1) Counting pulses from outside .....  | 6-2         |
| (2) Making output when a certain angle (pulses) is attained (Varicam control) ..... | 6-2         |
| (3) Simplified position control (to know work location) .....                       | 6-3         |
| <b>6-3 Counter Expansion FB Functions .....</b>                                     | <b>6-4</b>  |
| 6-3-1 Ring operation count range .....  | 6-4         |
| (1) For 16-bit positive rotation specification .....                                | 6-4         |
| (2) For 16-bit negative rotation specification .....                                | 6-4         |
| (3) For 32-bit positive rotation specification .....                                | 6-4         |
| (4) For 32-bit negative rotation specification .....                                | 6-4         |
| 6-3-2 Count operation mode .....  | 6-5         |
| (1) Ring operation mode .....   | 6-5         |
| (2) Gate operation mode .....   | 6-5         |
| <b>6-4 Details of Counter Expansion FB .....</b>                                    | <b>6-6</b>  |
| (1) Signal names for high-speed input expansion FB .....                            | 6-7         |
| <b>6-5 Memory Size of High-Speed Input Counter Expansion FB .....</b>               | <b>6-10</b> |
| <b>6-6 Settings for Ring and Gate Operations .....</b>                              | <b>6-10</b> |
| (1) Ring operation .....  | 6-10        |
| (2) Gate operation .....  | 6-10        |

# Section 6 High-Speed Input Counter Expansion FB

## 6-1 Overview of Counter Expansion FB

- The counter function can be achieved by using the high-speed input module (NP1X3206-A) together with the high-speed input counter expansion FB.
- The counter expansion FB specifications are as follows:

### **(1) Pulse input mode selection**

- 1) 90° phase difference pulse
- 2) Positive rotation pulse + Negative rotation pulse
- 3) Pulse command + Sign signal

### **(2) Operation mode**

- 1) Ring operation
- 2) Gate operation
- 3) Reset operation

### **(3) Counting range**

- 1) Signed binary 16 bits (–32768 to 32767)
- 2) Signed binary 32 bits (–2147483648 to 2147483647)

## 6-2 Sample Applications of Counter Expansion FB

### (1) Counting pulses from outside

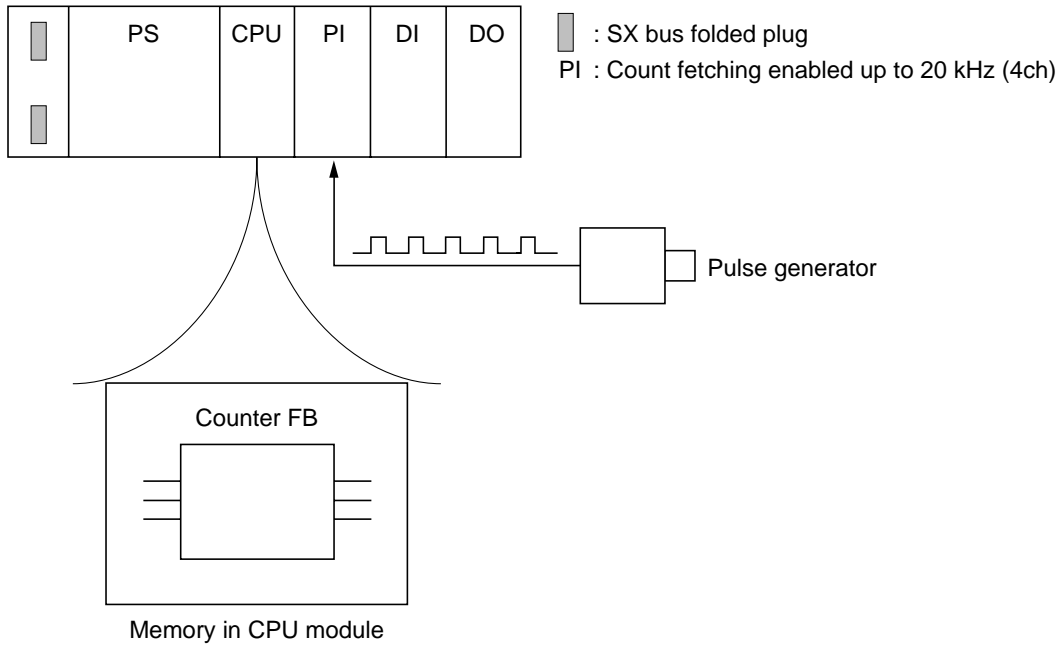

### (2) Making output when a certain angle (pulses) is attained (Varicam control)

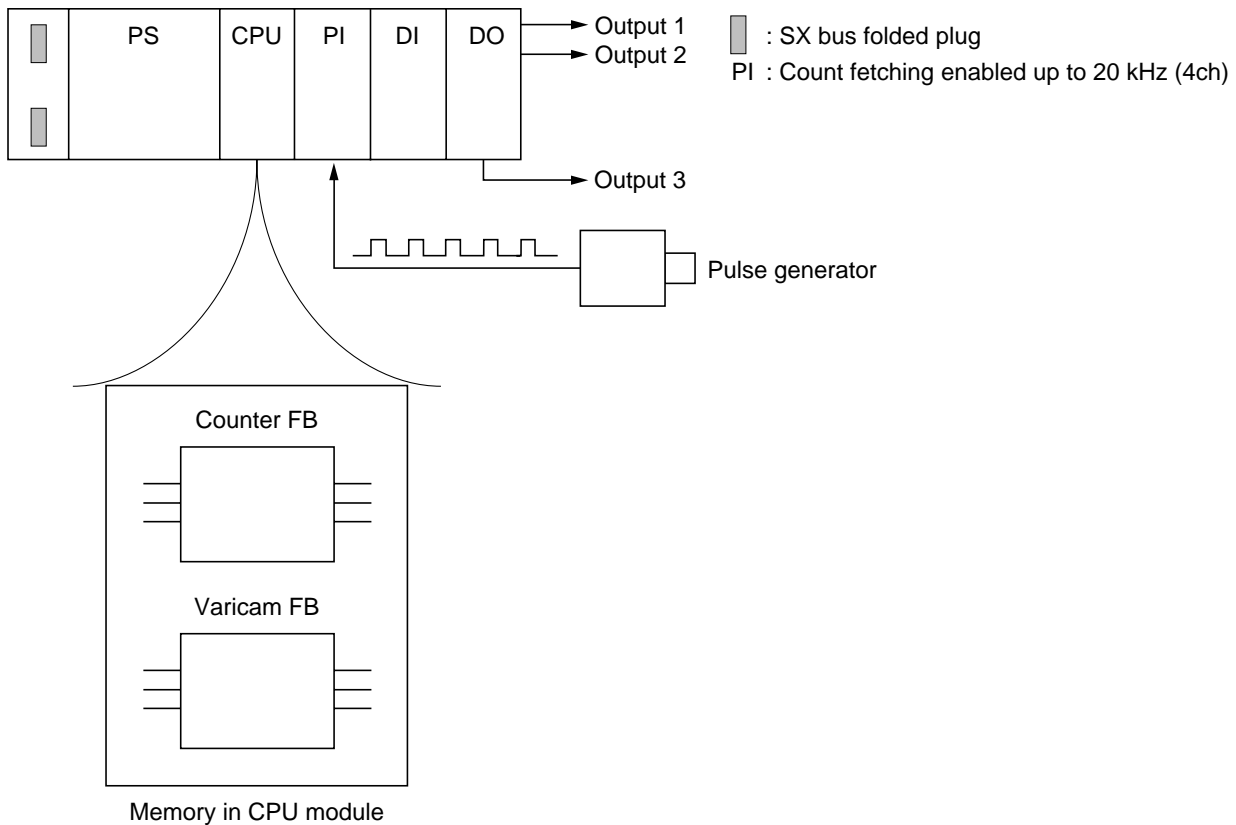

## 6-2 Sample Applications of Counter Expansion FB

### (3) Simplified position control (to know work location)

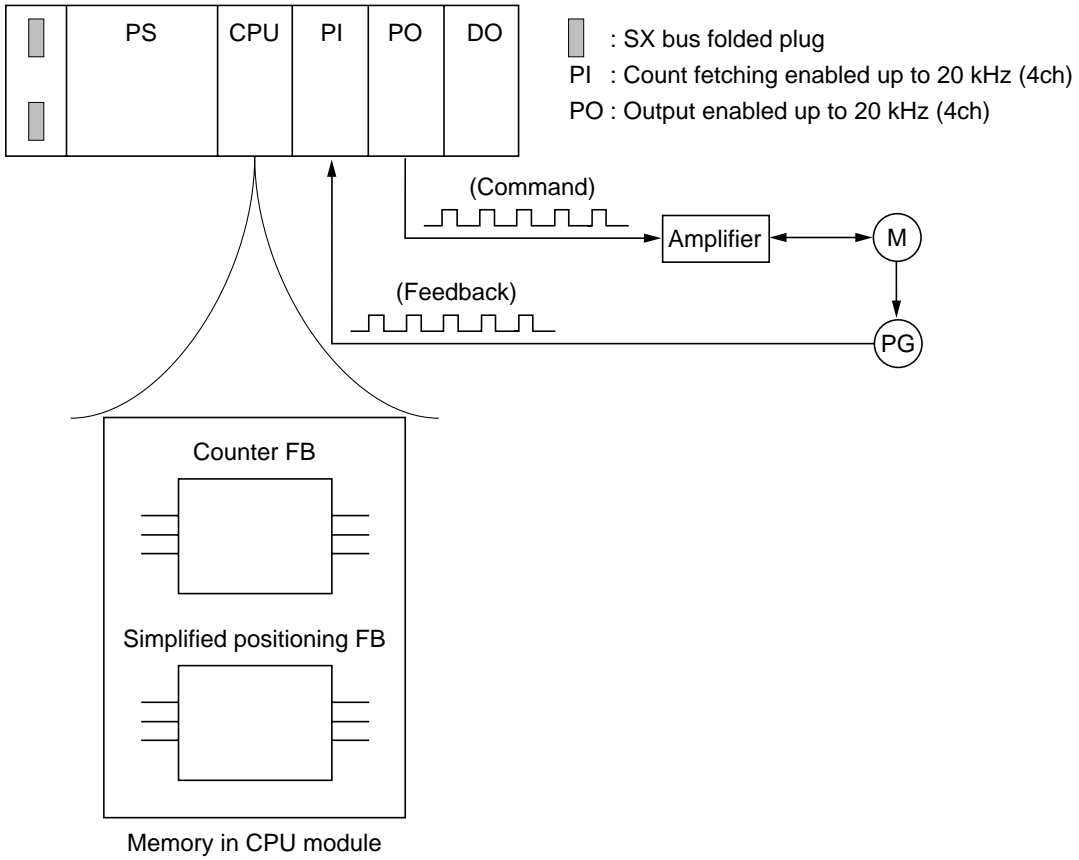

## 6-3 Counter Expansion FB Functions

- The counter expansion FB has the functions listed below.

| Functions       | Description   |
|-----------------|---|
| Ring operation  | Counting operation that leads to the minimum value when the maximum value is exceeded during pulse counting and to the maximum value when the minimum value is not attained |
| Gate operation  | Pulse counting operation performed only when the internal gate input is in counting enabled state   |
| Reset operation | Count value reset by internal reset input   |

### 6-3-1 Ring operation count range

- The count value always changes without causing overflow or underflow. The maximum value varies depending on the 16-/32-bit specification. For 32-bit specification, the input count value is output. For 16-bit specification, the high-order 16 bits are truncated from the input count value and the result is output.

#### (1) For 16-bit positive rotation specification

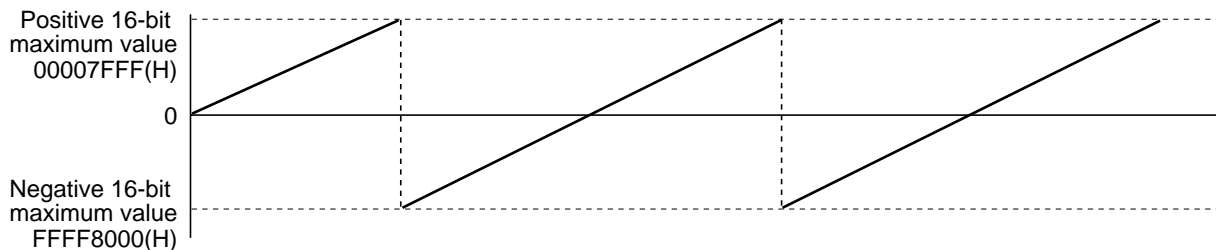

#### (2) For 16-bit negative rotation specification

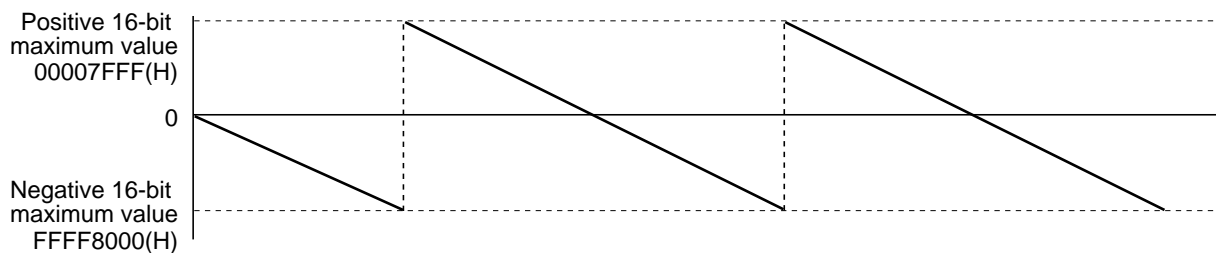

#### (3) For 32-bit positive rotation specification

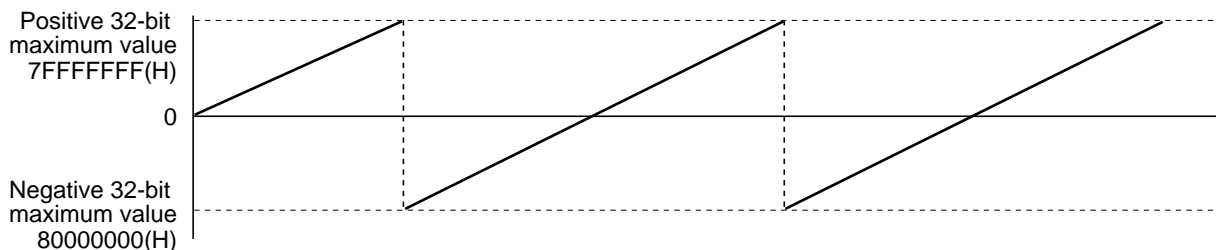

#### (4) For 32-bit negative rotation specification

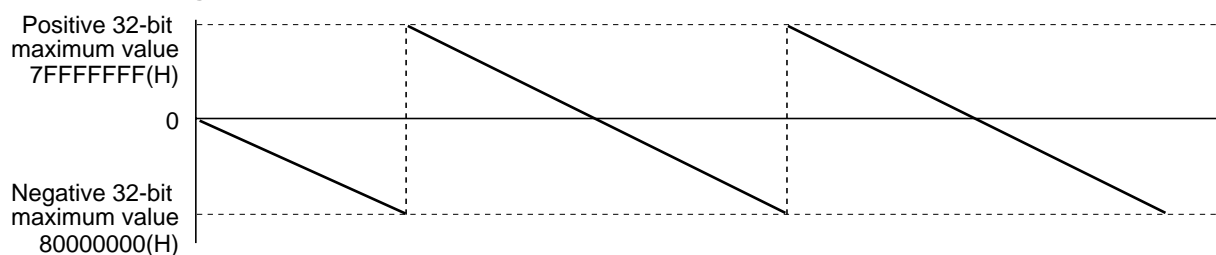

# 6-3 Counter Expansion FB Functions

## 6-3-2 Count operation mode

### (1) Ring operation mode

- Input pulse mode and 16-/32-bit count selection are set by the function block (FB). No overflow or underflow occurs.

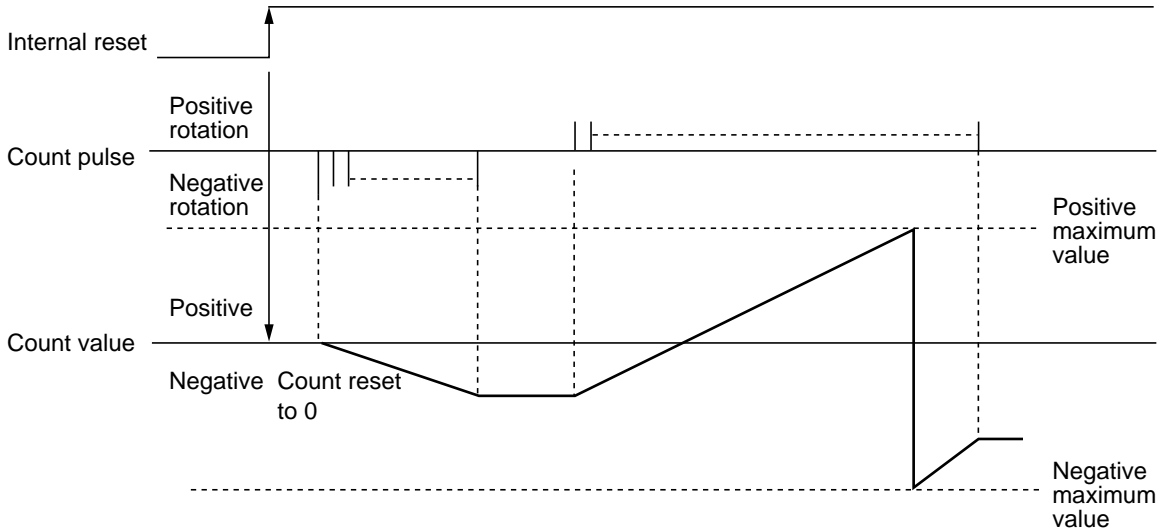

\* The counting range can be set to 16- or 32-bit signed binary value by internal setting.

### (2) Gate operation mode

- Pulse counting is performed when the internal gate input is in count enabled state.  
Internal gate: Counting enabled when the 4th bit of the bit command signal is ON. (Setting required for every four channels.)

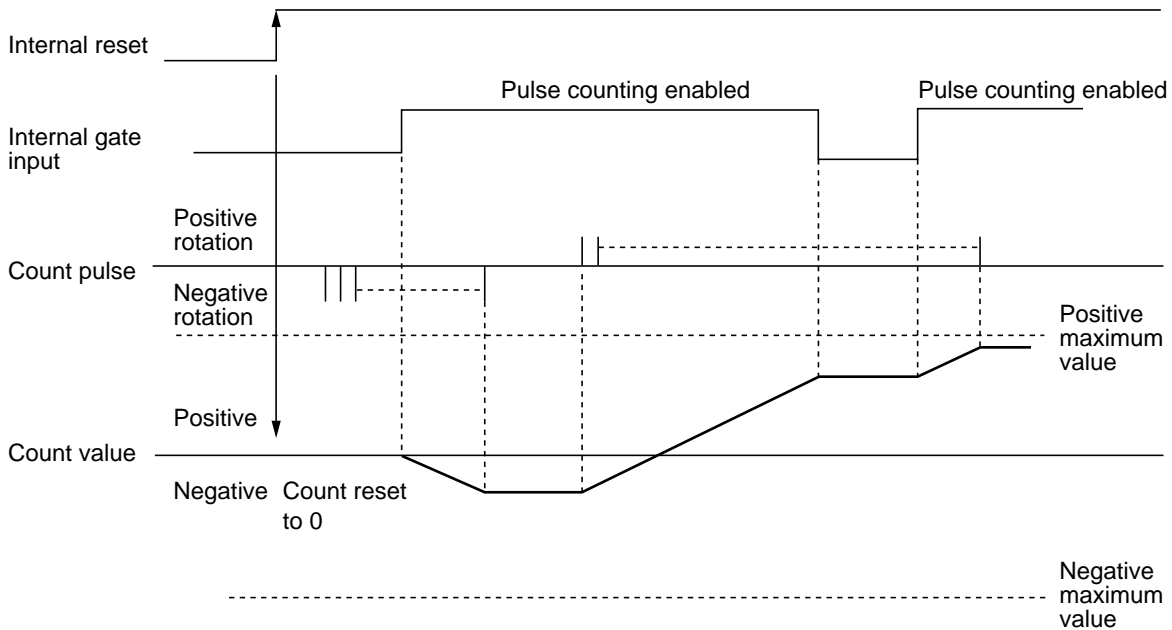

- \* Pulse counting is performed only when the internal gate input is in count enabled state.  
When the gate input is in the count disabled state, no pulse counting occurs for pulse inputs, if any.
- \* The counting range can be set to 16- or 32-bit signed binary value by internal setting.

# 6-4 Details of Counter Expansion FB

- The counter expansion FB configuration and I/O signal list are given below.

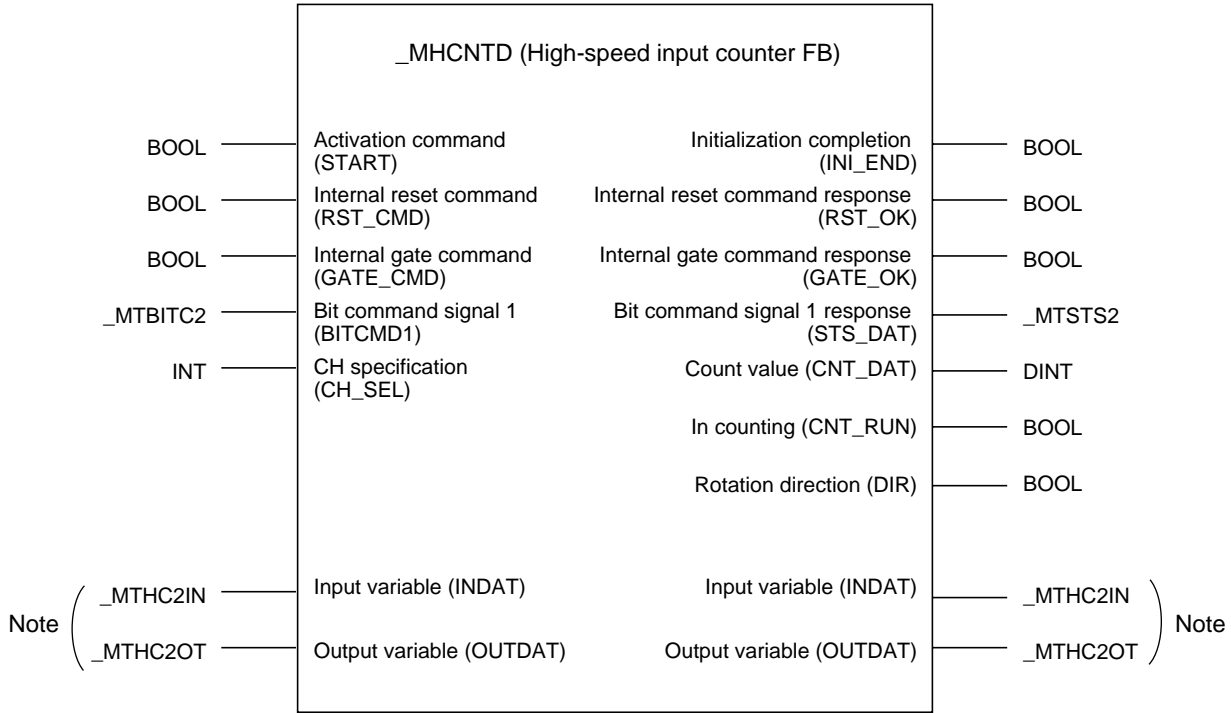

Note: Indicates the IN\_OUT parameter.

List of high-speed input counter FB I/O signals

| No. | Data names                      | Data type | I/O    | Signal variable names | Remarks |
|-----|---------------------------------|-----------|--------|-----------------------|---------|
| 1   | Activation command              | BOOL      | Input  | START                 |         |
| 2   | Internal reset command          | BOOL      | Input  | RST_CMD               |         |
| 3   | Internal gate command           | BOOL      | Input  | GATE_CMD              |         |
| 4   | Bit command signal 1            | _MTBITC2  | Input  | BITCMD1               |         |
| 5   | CH specification                | INT       | Input  | CH_SEL                |         |
| 6   | Initialization completion       | BOOL      | Output | INI_END               |         |
| 7   | Internal reset command response | BOOL      | Output | RST_OK                |         |
| 8   | Internal gate command response  | BOOL      | Output | GATE_OK               |         |
| 9   | Bit command signal 1 response   | _MTSTS2   | Output | STS_DAT               |         |
| 10  | Count value                     | DINT      | Output | CNT_DAT               |         |
| 11  | In counting                     | BOOL      | Output | CNT_RUN               |         |
| 12  | Rotation direction              | BOOL      | Output | DIR                   |         |
| 13  | Input variable                  | _MTHC2IN  | IN_OUT | INDAT                 |         |
| 14  | Output variable                 | _MTHC2OT  | IN_OUT | OUTDAT                |         |

### (1) Signal names for high-speed input expansion FB

#### 1) Activation command (START/BOOL)

“1”: Starts initialization processing (counter current value clear processing).

When initialization processing has completed, “initialization completion” goes ON.

At the activation command rising edge, the signal status of bit command signal 1 is reflected to the high-speed input module.

#### 2) Internal reset command (RST\_CMD/BOOL)

“1”: For the high-speed input module, sets “current value clear command” ON.

#### 3) Internal gate command (GATE\_CMD/BOOL)

- Command signal to be used when gate operation mode is enabled by count operation mode.

“1”: For the high-speed input module, sets “count enable command” ON.

“0”: For the high-speed input module, sets “count enable command” OFF.

#### 4) Bit command signal 1 (BITCMD1/\_MTBITC2 type with elements of BOOL type)

- At the rising edge of the activation command, this is reflected to the high-speed input module.

#### a) Input pulse mode (PLS\_U/PLS\_L)

“0”/“0”: 90° phase difference pulse

“0”/“1”: Positive rotation pulse + Negative rotation pulse

“1”/“0”: Sign signal + command pulse

“1”/“1”: Pulse counting inhibited

#### b) 16-/32-bit count selection (CNT\_SEL)

“0”: 16-bit count selection

“1”: 32-bit count selection

### Notes

- For the high-speed input module, only 16-bit count specification is enabled.  
By using the expansion FB, 16- or 32-bit specification can be selected.

#### c) Gate operation mode selection enable (GATE\_MOD)

“0”: Gate operation disabled (For high-speed input module, “count enable command signal” is always ON.

“1”: Gate operation enabled (Referencing the internal gate command, “count enable command signal” is set ON for the high-speed input module.

#### 5) CH specification (CH\_SEL/INT)

- For expansion FB, CH specification is enabled only for “0,” “1,” “2” or “3.”

#### 6) Internal reset command response (RST\_OK/BOOL)

- Used as a response signal for internal reset command (RST\_CMD).

#### 7) Internal gate command response (GATE\_OK/BOOL)

- Response signal for gate operation mode enable command.



## 6-4 Details of Counter Expansion FB

### 8) Bit command signal 1 response (STS\_DAT/\_MTSTS2 type with elements of BOOL type)

- Outputs operation mode of the high-speed input expansion FB after the rising edge of activation command (START).

#### a) Input pulse mode (PLS\_U/PLS\_L)

- “0”/“0”: 90fl phase difference pulse
- “0”/“1”: Positive rotation pulse + Negative rotation pulse
- “1”/“0”: Sign signal + command pulse
- “1”/“1”: Pulse counting inhibited

#### b) 16-/32-bit count selection (CNT\_SEL)

- “0”: 16-bit count selection
- “1”: 32-bit count selection

#### c) Gate operation mode selection enable (GATE\_MOD)

- “0”: Gate operation disabled (For the high-speed input module, “count enable command signal” is always ON.
- “1”: Gate operation enabled (Referencing the internal gate command, “count enable command signal” is set ON for the high-speed input module.

### 9) Count value (CNT\_DAT/DINT)

- Outputs the count value.
- The output range varies depending on the 16-/32-bit count selection.
- 16-bit specification: 8000 to 7FFF, -32768 to 32767
- 32-bit specification: 80000000 to 7FFFFFFF, -2147483648 to 2147483647

### 10) In counting (CNT\_RUN/BOOL)

- Outputs the high-speed input module counting status.
- “0”: Disabled
- “1”: Enabled

### 11) Rotation direction (DIR/BOOL)

- Indicates the status of the signal input to the high-speed input module.
- “0”: In positive rotation
- “1”: In negative rotation

### 12) Initialization completion (INI\_END/BOOL)

- Initialization completion goes ON when the initialization processing has completed after the rising edge of activation command (START).

### 13) Input variable (INDAT/\_MTHC2IN type with array of WORD type)

- Elements are in the array of I/O area in I/O map.
- The I/O areas are listed below.

| Address No. | 15 ←                        | 0 |
|-------------|-----------------------------|---|
| 0           | Pulse count register        |   |
| 1           | Input register 1            |   |
| 2           | Input register 2            |   |
| 3           | Pulse catch register 1      |   |
| 4           | Pulse catch register 2      |   |
| 5           | Pulse count data register 1 |   |
| 6           | Pulse count data register 2 |   |
| 7           | Pulse count data register 3 |   |
| 8           | Pulse count data register 4 |   |

## 6-4 Details of Counter Expansion FB

Supplementary explanation: Set the following in the program. (V000 is a tentative name.)

```
VAR
  V000 AT %IW[ ].0 : _MTHC2IN ;
END_VAR
```

Note: [ ] denotes an SX station No.

### 14) Output variable (OUTDAT/\_MTHC2OT type with array of WORD type)

- Elements are in the array of I/O area in I/O map.

| Address No. | 15 ←                                   | 0 |
|-------------|--|---|
| 0           | Pulse count register                   |   |
| 1           | Pulse catch register 1                 |   |
| 2           | Pulse catch register 2                 |   |
| 3           | Pulse catch enable edge set register 1 |   |
| 4           | Pulse catch enable edge set register 2 |   |

Supplementary explanation: Set the following in the program. (V001 is a tentative name.)

```
VAR
  V000 AT %QW[ ].9 : _MTHC2OT ;
END_VAR
```

Note: [ ] denotes an SX station No.

## 6-5 Memory Size of High-Speed Input Counter Expansion FB

| FB name                 | FB mnemonic | Object CP            | Positioning module | User program size | User FB instance | Retention data |
|-------------------------|-------------|----------------------|--------------------|-------------------|------------------|----------------|
| FB for high-speed input | _MHCNTD     | NP1PS-□□<br>NP1PH-□□ | NP1X3206-A         | 275               | 70               | —              |

## 6-6 Settings for Ring and Gate Operations

Settings for ring and gate operations using the high-speed input counter expansion FB are given below.

### (1) Ring operation

#### 1) Set CH specification (CH\_SEL) (INT type).

- The high-speed input module has counter functions for a maximum of four channels.

#### 2) Set bit command signal 1 (BITCMD1).

- Set the input pulse mode.
- Set the 16- or 32-bit counter to be used.  
(The high-speed input module is a 16-bit ring counter.)

#### 3) Activation command (START)

- Performs initialization processing.

### (2) Gate operation

#### 1) Set CH specification (CH\_SEL) (INT type).

- The high-speed input module has counter functions for a maximum of four channels.

#### 2) Set bit command signal 1 (BITCMD1).

- Set the input pulse mode.
- Set the 16- or 32-bit counter to be used.  
(The high-speed input module is a 16-bit ring counter.)
- Set gate operation enable (GATE\_CMD).

#### 3) Set internal gate command (GATE\_CMD).

#### 4) Activation command (START)

- Performs initialization processing.

---

## **Fuji Electric Co., Ltd.**

Gate City Ohsaki, East Tower,  
11-2, Osaki 1-chome, Shinagawa-ku, Tokyo 141-0032, Japan

E-mail: [micrex-sx@fujielectric.co.jp](mailto:micrex-sx@fujielectric.co.jp)  
URL: <http://www.fujielectric.com/>

---

Materials covered in this document are subject to revision due to the modification of the product.

Issued as FE consolidated edition, June 2011