



# EXPLORER



## *USER'S MANUAL*



This is HIGH-POWER item; please DO NOT USE THE SAME OUTLET WITH OTHER HIGH-POWER HOUSEHOLD APPLIANCE like air-conditioning etc. Please choose an outlet exclusively for the machine and make sure the fuse is 10A.

**Product may vary slightly from the item pictured due to model upgrades**

# Contents

<b>1. IMPORTANT SAFETY INSTRUCTIONS</b> .....	2
<b>1.1 IMPORTANT ELECTRICAL INFORMATION</b> .....	3
<b>1.2 IMPORTANT OPERATION INSTRUCTIONS</b> .....	3
<b>2. BRIEF DESCRIPTION</b> .....	4
<b>3. MAIN TECHNICAL FEATURES</b> .....	5
<b>4. OPERATING INSTRUCTION</b> .....	6
<b>4.1 Keys for Meter Panel</b> .....	6
<b>4.2 Getting Started</b> .....	8
<b>4.3 Self-Checking</b> .....	8
<b>4.4 Quick-Start Operation</b> .....	8
<b>4.5 Incline Feature</b> .....	9
<b>4.6 Pulse Grip Feature</b> .....	9
<b>4.7 Calorie Display</b> .....	9
<b>4.8 Folding and Unfolding Treadmill</b> .....	9
<b>4.8.1 Folding</b> .....	9
<b>4.8.2 Unfolding</b> .....	10
<b>4.8.3 Transport</b> .....	10
<b>4.9 Programmable Operations</b> .....	10
<b>4.10 To Select a Program</b> .....	10
<b>4.11 User Program</b> .....	10
<b>5. MAINTENANCE</b> .....	19
<b>5.1 General Cleaning</b> .....	20
<b>5.2 General Care</b> .....	21
<b>5.3 Belt/Deck/Roller Lubrication</b> .....	21
<b>5.4 How to check the running mat for proper lubrication</b> .....	21
<b>5.5 Belt Adjustment</b> .....	22
<b>5.6 Belt Tracking Adjustment</b> .....	22
<b>6. TROUBLE SHOOTING</b> .....	23
<b>6.1 Alarm signals</b> .....	23
<b>7. EXERCISE GUIDE</b> .....	24
<b>8. SPARE PARTS LIST</b> .....	25
<b>9. INSTALLATION GUIDE</b> .....	26
<b>10. WARRANTY REGISTRATION</b> .....	29

# 1. IMPORTANT SAFETY INSTRUCTIONS

**WARNING** - Read all instructions before using this treadmill.

It is important your treadmill receives regular maintenance to prolong its useful life. Failing to regularly maintain your treadmill may void your warranty.

**Danger**—To reduce the risk of electric shock disconnect your treadmill from the electrical outlet prior to cleaning and/or service work.

DO NOT USE AN EXTENSION CORD: DO NOT ATTEMPT TO DISABLE THE GROUNDED PLUG BY USING IMPORPER ADAPTERS OR IN ANY WAY MODIFY THE CORD SET.

- Install the treadmill on a flat level surface with access to a 220-240 volt (50/60Hz), grounded outlet.
- Do not operate treadmill on deeply padded, plush or shag carpet. Damage to both carpet and treadmill may result.
- Do not block the rear of the treadmill. Provide a minimum of 1 metre clearance between the rear of the treadmill and any fixed object.
- Place your unit on a solid, level surface when in use.
- Never allow children on or near the treadmill.
- When running, make sure the plastic clip is fastened on your clothing. It is for your safety, should you fall or move too far back on the treadmill.
- Keep hands away from all moving parts.
- Never operate the treadmill if it has a damaged cord or plug.
- Keep the cord away from heated surfaces.
- Do not operate where aerosol spray products are being used or where oxygen is being administered. Sparks from the motor may ignite a highly flammable environment.
- Never drop or insert any object into any openings.
- The treadmill is intended for in-home use only and not suitable for long time running.
- To disconnect, turn all controls to the off position, remove the safety key, and then remove the plug from the outlet.

- The pulse sensors are not medical devices. Various factors, including the user's movement, may affect the accuracy of heart rate readings. The pulse sensors are intended only as exercise aids in determining heart rate trends in general.
- Use handrails provided; they are for your safety.
- Wear proper shoes. High heels, dress shoes, sandals or bare feet are not suitable for use on your treadmill. Quality athletic shoes are recommended to avoid leg fatigue.
- Allowed temperature: 5 to 40 degrees.

Remove the safety key after use to prevent unauthorized treadmill operation.

## 1.1 IMPORTANT ELECTRICAL INFORMATION

### WARNING!

- NEVER use a ground fault circuit interrupt (GFCI) wall outlet with this treadmill. Route the power cord away from any moving part of the treadmill including the elevation mechanism and transport wheels.
- NEVER remove any cover without first disconnecting AC power.
- NEVER expose this treadmill to rain or moisture. This treadmill is not designed for use outdoors, near a pool, or in any other high humidity environment.

## 1.2 IMPORTANT OPERATION INSTRUCTIONS

- Be sure to read the entire manual before operating your machine.
- Understand that changes in speed and incline do not occur immediately. Set your desired speed on the computer console and release the adjustment key. The computer will obey the command gradually.
- Use caution while participating in other activities while walking on your treadmill; such as watching television, reading, etc. These distractions may cause you to lose balance or stray from walking in the centre of the belt; which may result in serious injury.
- In order to prevent losing balance and suffering unexpected injury, **NEVER** mount or dismount the treadmill while the belt is moving. This unit starts with a very low speed. Simply standing on the belt during slow acceleration is proper after you have learned to operate this machine.
- Always hold on to handrail while making control changes.

- A safety key is provided with this machine. Remove the safety key will stop the walking belt immediately; the treadmill will shut off automatically. Insert the safety key will reset the display.
- Do not use excessive pressure on console control keys. They are precision set to function properly with little finger pressure.

## 2.BRIEF DESCRIPTION

This motorized treadmill (Diagram 1) can help achieve your goal of staying fit. Together with the unique, elegant and dignified shape, it takes a little space when folded by gasoline spring and the large Meter Panel provides easy readability of the parameters. Its speed range is 1.0-18km/h.

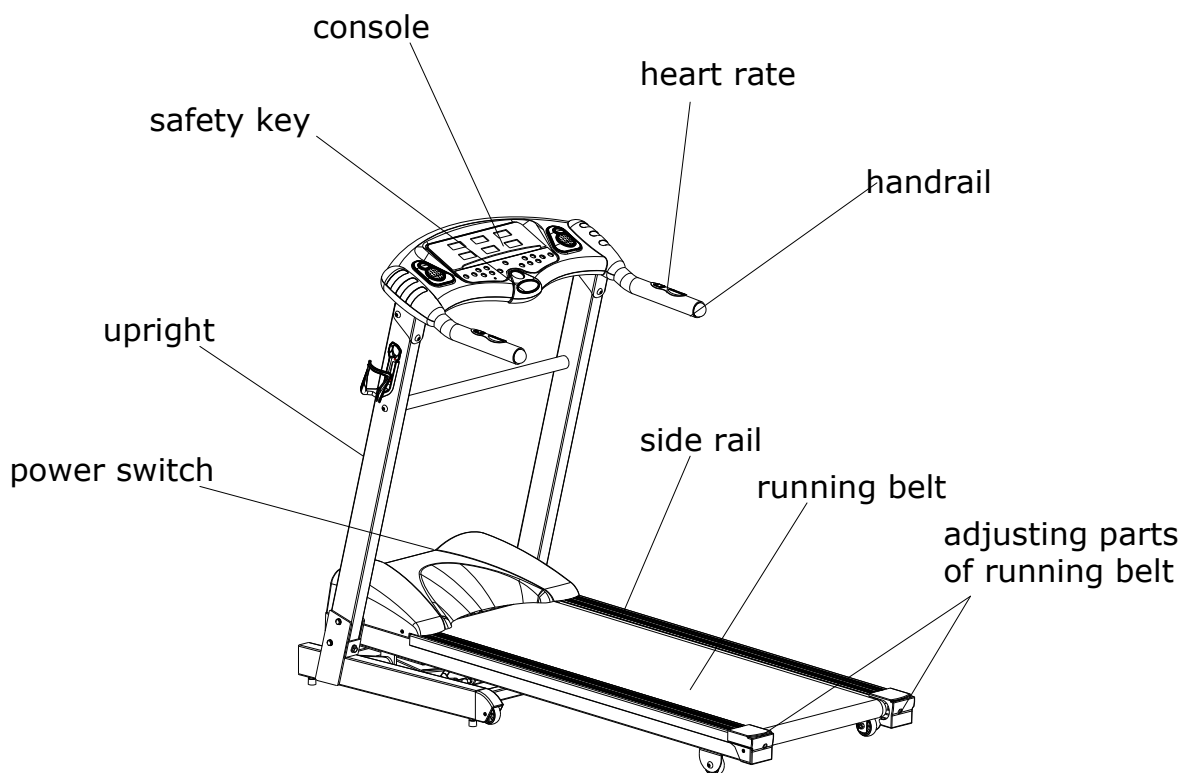

### 3. MAIN TECHNICAL FEATURES

Main use: exercise, keeping fit

This treadmill is only for home use

Constant running time: < 2 hours, it can't be less than 1 hour between two running times

Once the machine runs for one month or 40 hours, please add 20ml silicone oil on the deck

Parameters: speed, time, distance, heart rate, calorie

Display: LED

Input voltage: 240V

Frequency: 50Hz

Input current: ≤10A

Temperature for running: 5∞40degrees

It has MP3 feature, music speakers, water holder, be foldable

Speed range: 1∞18km/h

Auto incline: 0-18 levels

Running surface: 450\*2600mm

Program: 15 pre-set programs

Time display range:0:00∞99:59 (minutes : seconds);

Distance display range: 0.00~9.99km

Calorie display range: 0.00~999 calorie

Machine size (L\*W\*H): 1630\*710\*1250mm

# 4. OPERATING INSTRUCTION

## 4.1 Keys for Meter Panel

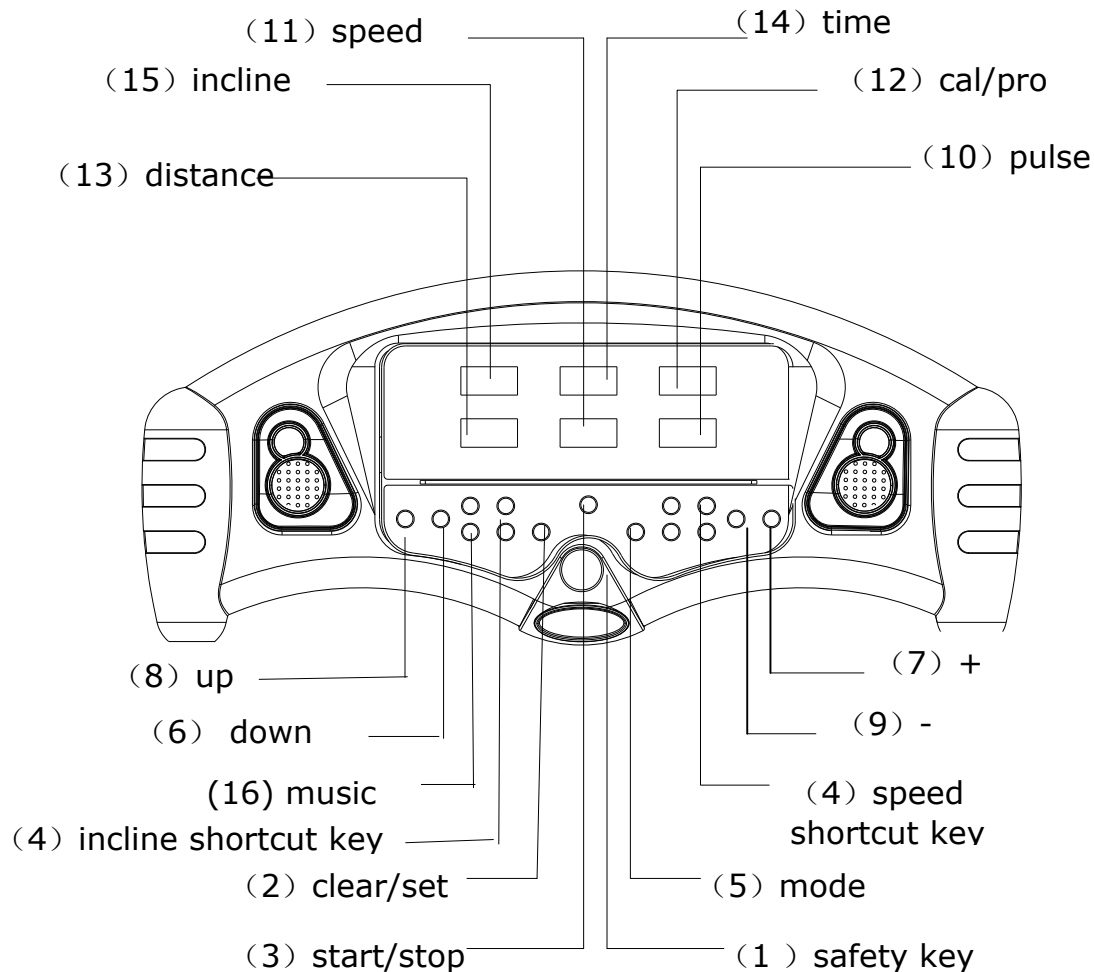

(1) "safety key"

If the urgent condition occurs, pull this key, the machine stops immediately.

(2) "clear/set" key

Under ready condition, press this key, it will clear all the operation

Under ready condition, press this key for 3 seconds continuously, time, distance and calorie can be set. Press "+" and "-" keys, the values of time, distance and calorie can be set. Then press "start/stop" key, the machine will run at 1.0km/h. And the set figures will be counted down, when it comes to "0", machine stops.

Under running situation, press "clear/set", all the figures will be kept to "0" except for speed. Then hand model comes.

(3) "start/stop" key

Under ready condition, press this key, it runs at 1.0km/h speed. Under running condition, if it runs at speed more than 3.5km/h, it will slow down then stop. During this stopping process, other keys don't take use. If it runs at speed less than 3.5km/h, it stops immediately.

(4) "speed shortcut key" "incline shortcut key"

Under running condition, press this key, speed/incline can be set to the values directly.

(5) "mode" key

Under ready condition, press this key, you can choose program for running.

(6) "down" key

Under setting condition, press this key, the number can be reduced to the ones you need.

(7) "speed up" key

Under running condition, press this key, speed can be speeded up to the ones you need.

(8) "up" key

Under setting condition, press this key, the number can be increased to the ones you need.

(9) "speed down" key

Under running condition, press this key, speed can be speeded down to the ones you need.

(10) "pulse" window

It shows heart rate.

(11) "speed" window



It shows speed. (range:1km/h-18km/h)

(12) "cal/pro" window

It shows calorie. (range:0-999 calorie)

(13) "distance" window

It shows the distance.(range:0 km-9.99km)

(14) "time" window

It shows time. (range:00:00 -99:99)

(15) "incline" window

It shows incline. (range:0-18 levels)

(16)" music" button

Press this button, play music; while press it again, music stops.

## 4.2 Getting Started

Power the treadmill on by plugging it into an appropriate wall outlet, then turn on the power switch located at the front of the treadmill below the motor shield. Ensure that the **safety key** is installed, as the treadmill will not power on without it. When the power is turned on, all the lights on the display will light for a short time.

## 4.3 Self-Checking

When using for the first time, it is necessary to make the machine carry on self-check:

- Remove the safety key, press *MODE* and hold, then insert the safety key again, the machine enters into self-checking state. During this state, pressing *START/STOP* can terminate the self-checking.

## 4.4 Quick-Start Operation

1. Press and release the *START/STOP* to wake display up (if not already on). Note: Installing the safety key will also wake up the console.

2. Press and release the *START/STOP* to begin belt movement, at 1.0 Km/hr, then adjust to the desired speed using the '+' or '-'. You may also use the rapid speed keys (3, 6, 9 and 12) to adjust the speed. The speed range is from 1.0km/h to 18.0km/h. You can also use '+' or '-' to adjust the speed on handrail.
3. To slow the treadmill down, press and hold the '-' key to desired speed. You may also press the rapid speed adjust keys: 3, 6, 9, 12.
4. In a state of running, single press *START/STOP*, the walking belt will gradually slow down if the speed is above 3.5km/h, if under 3.5km/h, then it will stop immediately.
5. In the state of running, single press *CLEAR* will reset all number except the speed. Then enter into manual mode.
6. To stop the tread-belt press and release the *START/STOP*.

## **4.5 Incline Feature**

- Incline may be adjusted anytime after belt movement.
- The incline range is from 0 to 18levels
- Press the 'up' or 'down' to achieve desired level of effort. Four Quick access key of 3, 6 and 9 are also available to adjust the incline percent.
- You can also adjust the incline percent by using the '+' or '-' on handrail.
- The display will indicate incline percent as adjustments are made.
- Incline will remain in its position when display is turned off.

## **4.6 Pulse Grip Feature**

The Pulse (Heart Rate) console window will display your current heart rate in beats per minute during the workout. You must use both stainless steel sensors to display your pulse. Pulse value displays anytime the upper display is receiving a Grip Pulse signal.

## **4.7 Calorie Display**

Displays the cumulative calories burned at any given time during your workout.

Note: This is only a rough guide used for comparison of different exercise sessions, which cannot be used for medical purposes.

## **4.8 Folding and Unfolding Treadmill**

### **4.8.1 Folding**

First, lift the back part of the frame board with your hand till you hear a light sound, which means the folding system has been locked. Running board can't be turned to the opposite direction now.

### **4.8.2 Unfolding**

Put the folded treadmill in a capacious position when you want to run.

### **4.8.3 Transport**

Carefully lift the treadmill at the rear roller area, grasping the two side end caps, and roll the treadmill away.

## **4.9 Programmable Operations**

This treadmill offers 3 user programs (C1, C2, C3) and 12 preset programs (P1,P2, P3.....P12, see attachment). The first 9 preset programs (P1 to P9) are only for speed; the last 3 preset programs (P10 to P12) are a combination on speed and incline. Be careful when using the last 3 present programs as they are designed for advanced users. Children under 16 years of age are not recommended to use the last 3 preset programs. Each preset program has a maximum speed level that is displayed when a desired workout is chosen. The speed that the particular program will achieve will be displayed in the Speed window. Each program has various speed changes throughout.

### **4.10 To Select a Program**

- Make sure the machine is in the stop position, single press '*clear/set*' to enter into resetting state. Press '*MODE*' to choose desired program (P1,P2, .....P12), then press and release '*START/STOP*' to begin the program with default values.
- The speed window will now be showing the preset speed of the selected program.
- Each program will continue 30 minutes. After every one minute program and speed can be altered manually or automatically. 3 Seconds before the ending of program a buzzer will sound three times, then the running belt will come to a stop.

### **4.11 User Program**

In the resetting state, select C1, C2 and C3 by pressing the 'mode' key once. Then press 'clear/set', the display for 'time' and 'speed' will be flashing at the same time. (Note: the incline window will show the time temporarily).

Press 'mode' to adjust the time with default value of 30 minutes (the time will vary every two minutes).

Press "+" or "-" to adjust speed contrary to the selected time period.

Repeat the above two processes until all the parameters have been programmed.

Press and release the "START/STOP" key, the running belt will then start to run according to the workout created. (NOTE: THIS PROGRAM WILL BE SAVED TO THE TREADMILL MEMORY FOREVER).

**P1**

<b>TIME (mins)</b>	1	2	3	4	5	6	7	8	9	10	11	12	13	14	15	16	17	18	19	20	21	22	23	24	25	26	27	28	29	30
<b>SPEED (Km/h)</b>	1	2	2	2	3	3	3	4	4	4	4	5	5	5	5	5	6	6	6	6	7	7	7	7	8	8	8	9	9	9

**P2**

<b>TIME (mins)</b>	1	2	3	4	5	6	7	8	9	10	11	12	13	14	15	16	17	18	19	20	21	22	23	24	25	26	27	28	29	30
<b>SPEED (Km/h)</b>	9	9	9	8	8	8	8	8	7	7	7	7	6	6	6	6	5	5	5	5	4	4	4	4	3	3	2	2	1	1

**P3**

<b>TIME (mins)</b>	1	2	3	4	5	6	7	8	9	10	11	12	13	14	15	16	17	18	19	20	21	22	23	24	25	26	27	28	29	30
<b>SPEED (Km/h)</b>	4	4	4	5	5	5	6	6	6	6	7	7	7	8	8	8	8	9	9	8	8	8	7	7	7	6	5	4	4	4

**P4**

<b>TIME (mins)</b>	1	2	3	4	5	6	7	8	9	10	11	12	13	14	15	16	17	18	19	20	21	22	23	24	25	26	27	28	29	30
<b>SPEED (Km/h)</b>	4	4	4	5	5	5	6	6	6	6	7	7	6	6	6	7	7	7	8	8	8	9	9	9	8	8	8	6	5	4

**P5**

<b>TIME (mins)</b>	1	2	3	4	5	6	7	8	9	10	11	12	13	14	15	16	17	18	19	20	21	22	23	24	25	26	27	28	29	30
<b>SPEED (Km/h)</b>	4	5	5	5	6	6	6	8	8	8	5	5	5	6	6	6	9	9	9	5	5	5	5	9	9	9	6	6	5	5

**P6**

<b>TIME (mins)</b>	1	2	3	4	5	6	7	8	9	10	11	12	13	14	15	16	17	18	19	20	21	22	23	24	25	26	27	28	29	30
<b>SPEED (Km/h)</b>	6	6	7	7	7	8	8	8	8	9	9	9	9	9	8	8	8	8	9	9	9	8	8	8	9	9	9	8	8	8

**P7**

<b>TIME (mins)</b>	1	2	3	4	5	6	7	8	9	10	11	12	13	14	15	16	17	18	19	20	21	22	23	24	25	26	27	28	29	30
<b>SPEED (Km/h)</b>	4	4	4	5	5	5	6	6	6	6	7	7	7	7	8	8	8	9	9	9	8	8	8	7	7	6	6	6	5	5

**P8**

<b>TIME (mins)</b>	1	2	3	4	5	6	7	8	9	10	11	12	13	14	15	16	17	18	19	20	21	22	23	24	25	26	27	28	29	30
<b>SPEED (Km/h)</b>	3	3	3	4	4	5	5	6	6	7	7	9	9	9	8	8	7	7	6	6	8	8	9	9	9	9	8	8	7	7

**P9**

<b>TIME (mins)</b>	1	2	3	4	5	6	7	8	9	10	11	12	13	14	15	16	17	18	19	20	21	22	23	24	25	26	27	28	29	30
<b>SPEED (Km/h)</b>	4	4	5	5	6	7	7	9	9	8	3	3	9	9	4	4	8	8	9	9	5	5	5	8	8	7	5	5	4	4

**P10**

<b>TIME (mins)</b>	1	2	3	4	5	6	7	8	9	10	11	12	13	14	15	16	17	18	19	20	21	22	23	24	25	26	27	28	29	30
<b>SPEED (Km/h)</b>	3	4	5	6	5	6	6	5	4	2	1	2	3	6	7	6	6	5	4	2	6	5	3	6	4	3	6	5	4	2
<b>INCLINE (level)</b>	7	5	3	5	9	4	2	4	6	8	10	12	1	2	3	4	5	6	7	8	9	2	1	2	1	2	1	1	2	0

**P11**

<b>TIME (mins)</b>	1	2	3	4	5	6	7	8	9	10	11	12	13	14	15	16	17	18	19	20	21	22	23	24	25	26	27	28	29	30
<b>SPEED (Km/h)</b>	5	5	5	5	5	5	5	5	5	5	5	5	5	5	5	5	5	5	5	5	5	5	5	5	5	5	5	5	5	5
<b>INCLINE (level)</b>	3	1	2	3	4	4	3	2	1	0	1	1	2	3	4	4	3	2	1	0	1	1	2	3	4	4	3	2	1	0

**P12**

<b>TIME (mins)</b>	1	2	3	4	5	6	7	8	9	10	11	12	13	14	15	16	17	18	19	20	21	22	23	24	25	26	27	28	29	30
<b>SPEED (Km/h)</b>	5	5	3	3	3	9	9	9	9	7	7	7	6	6	9	9	9	9	5	5	5	7	7	7	7	6	6	6	6	6
<b>INCLINE (level)</b>	1	3	5	7	9	11	9	7	5	3	1	3	5	7	9	11	9	7	5	3	1	3	5	7	9	11	9	7	5	3

Program 1

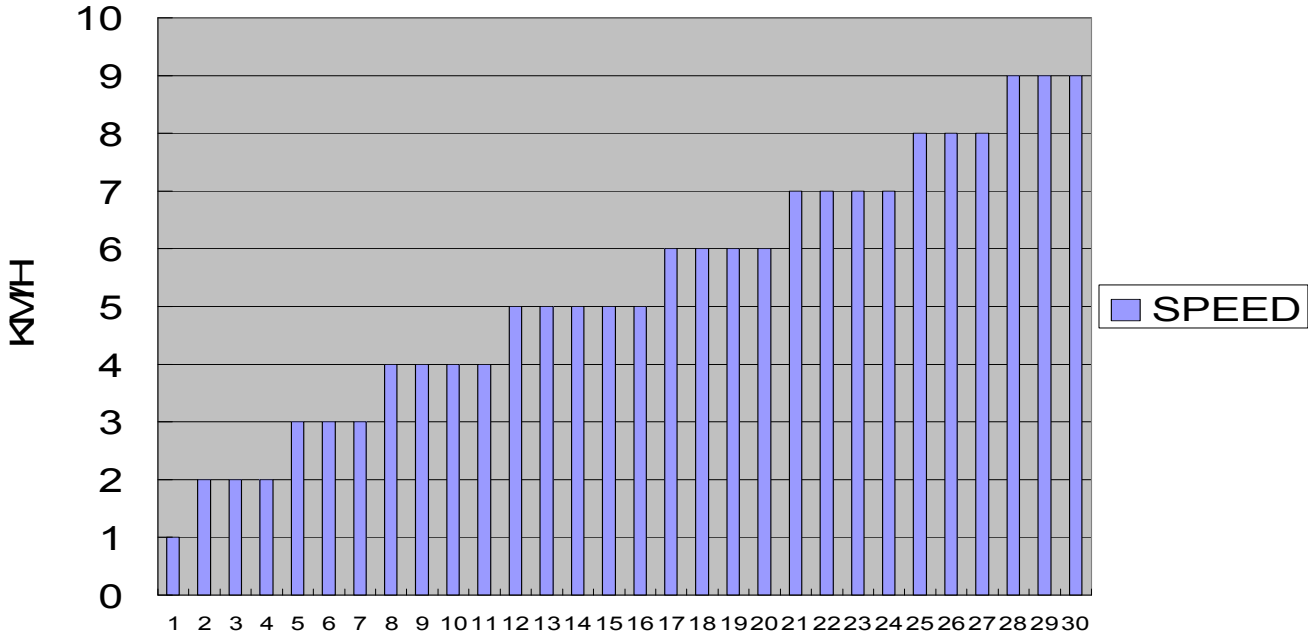

Program 2

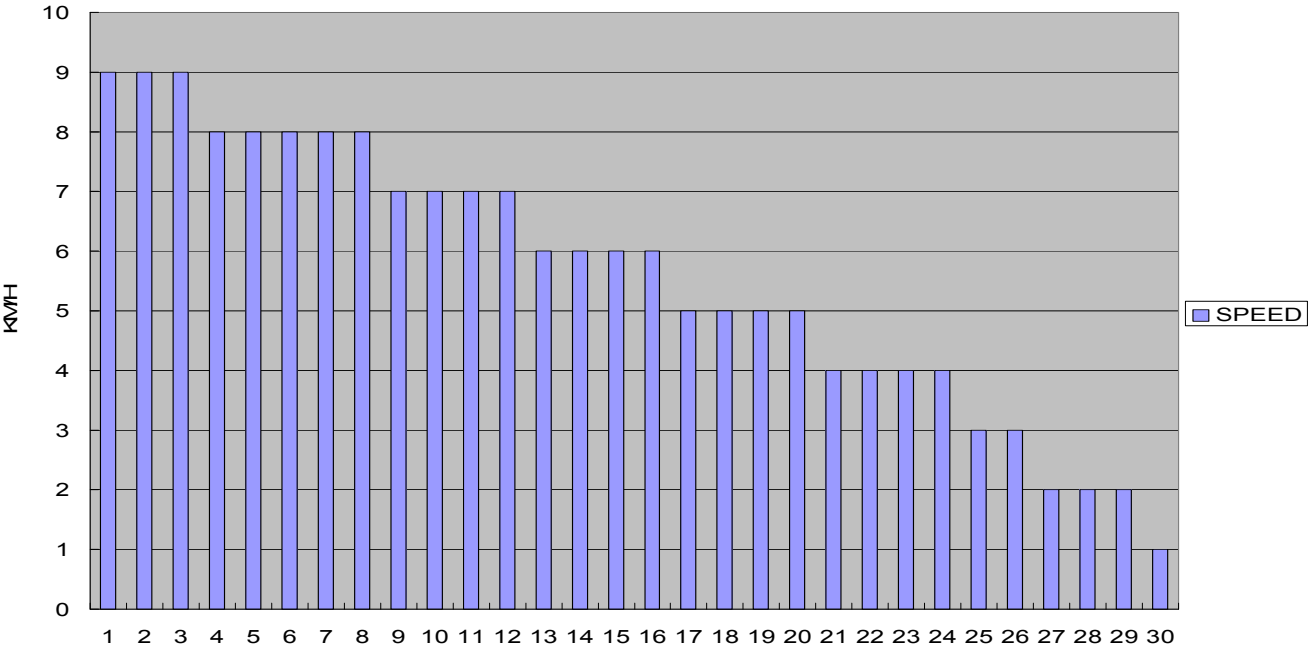

Program 3

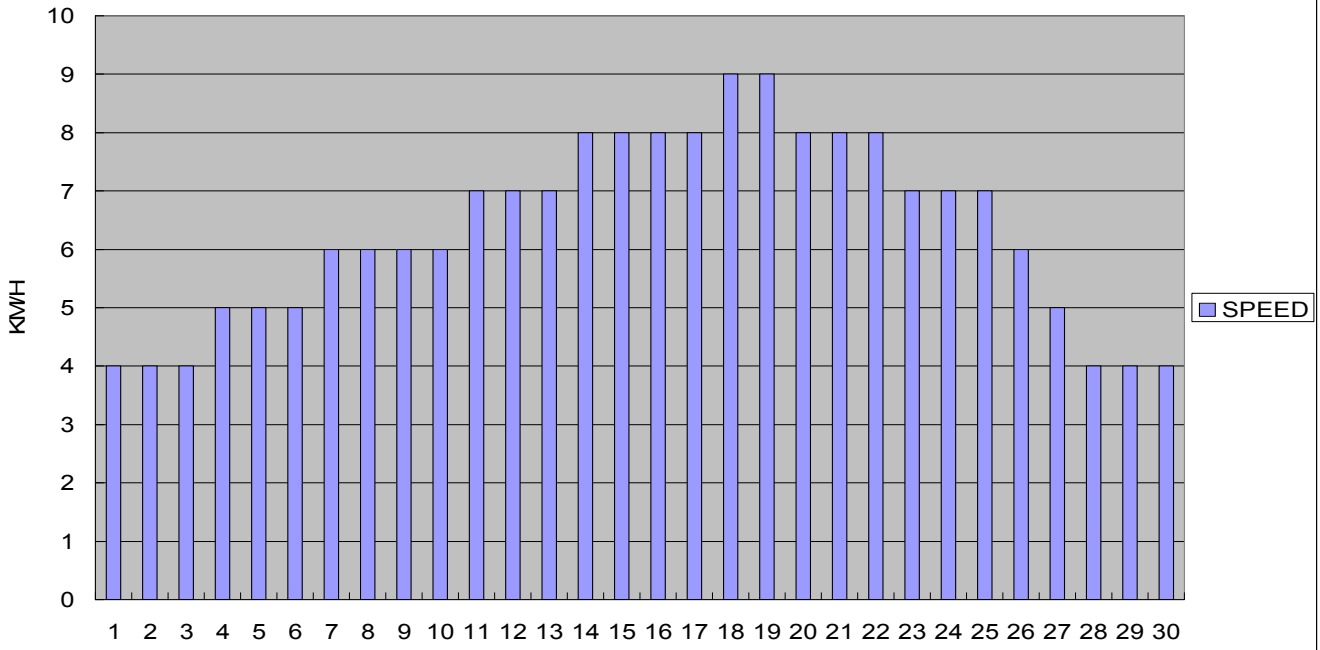

Program 4

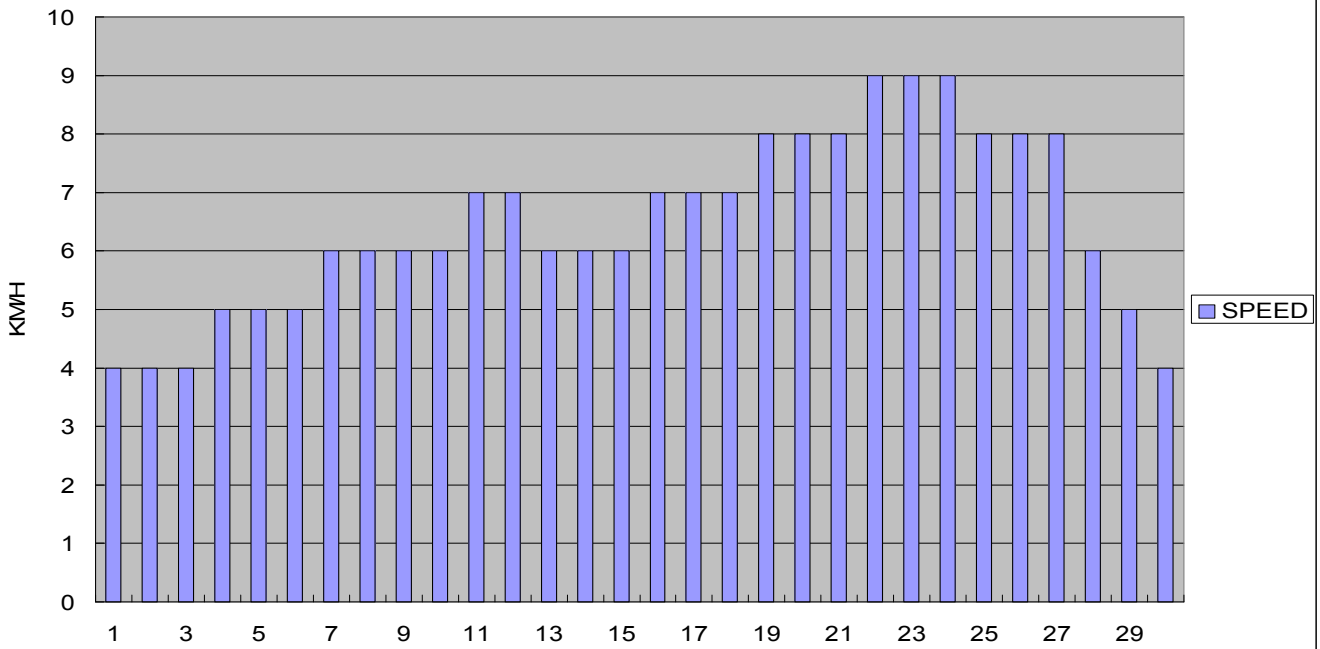

Program 5

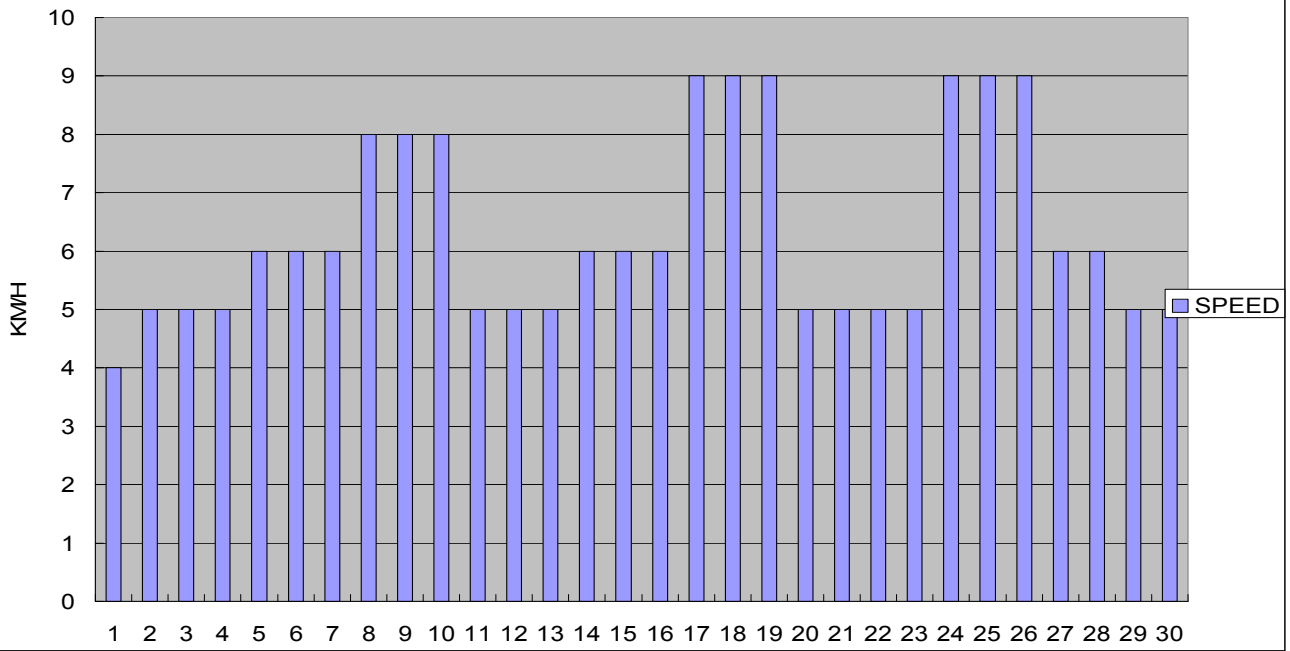

Program 6

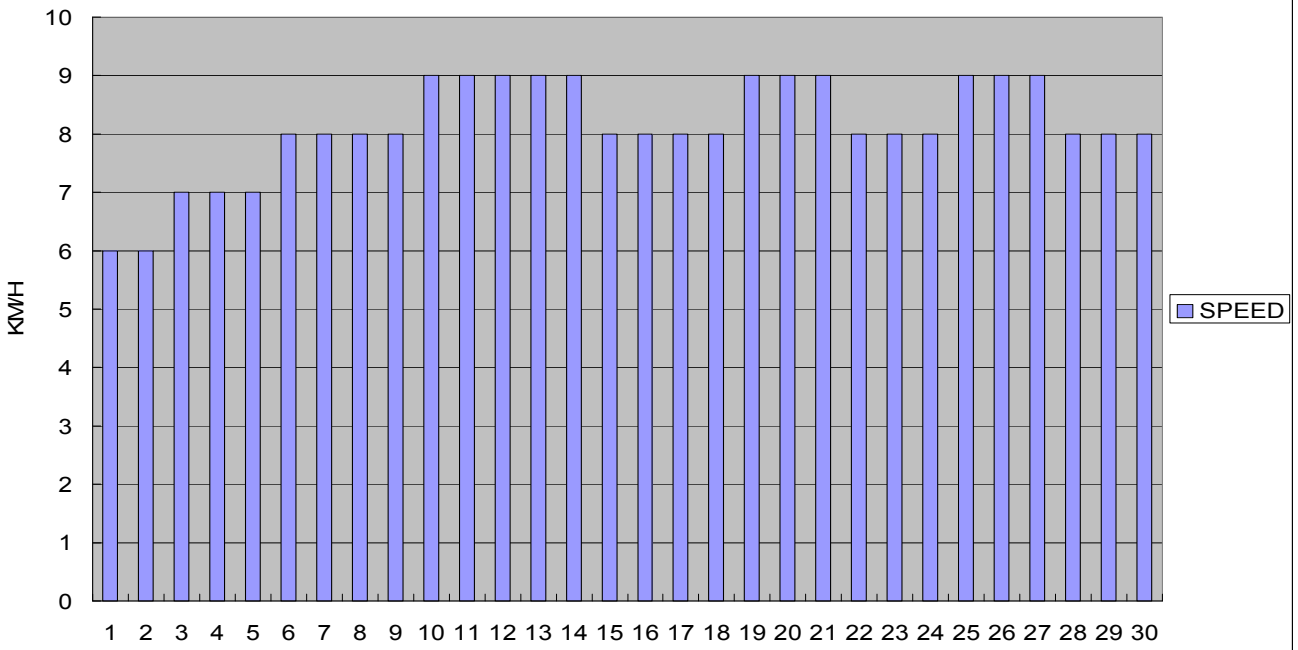



Program 7

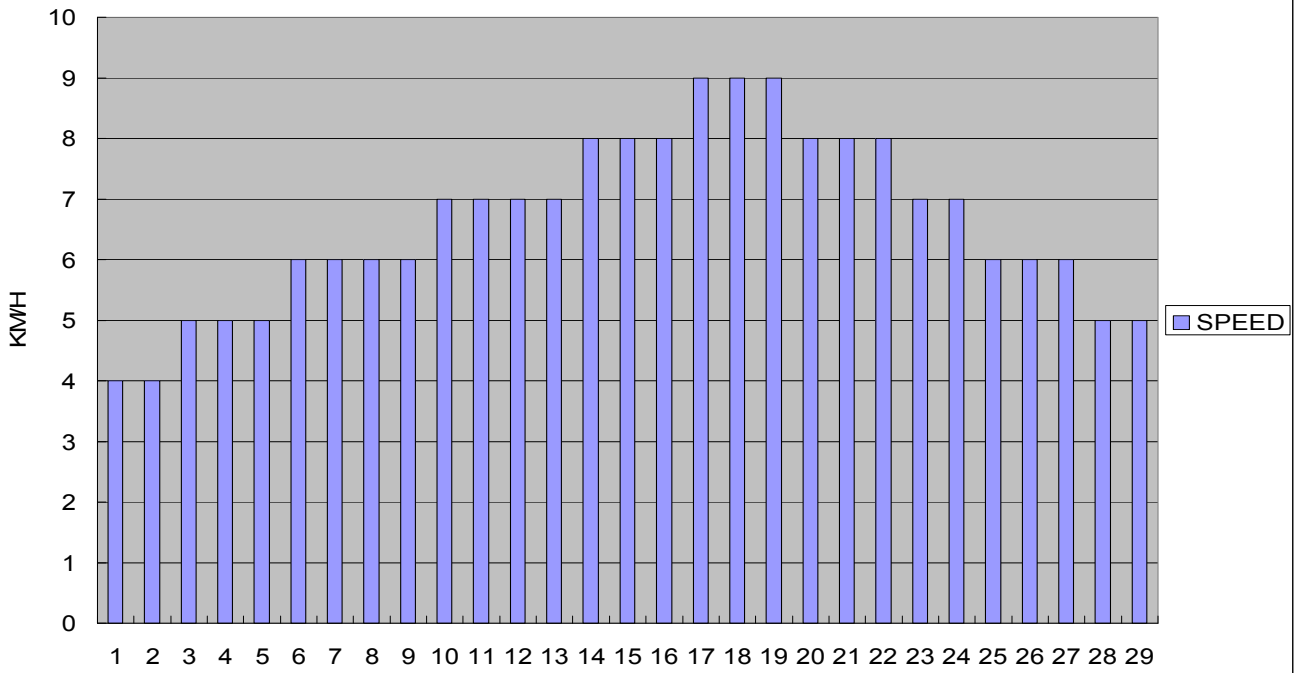

Program 8

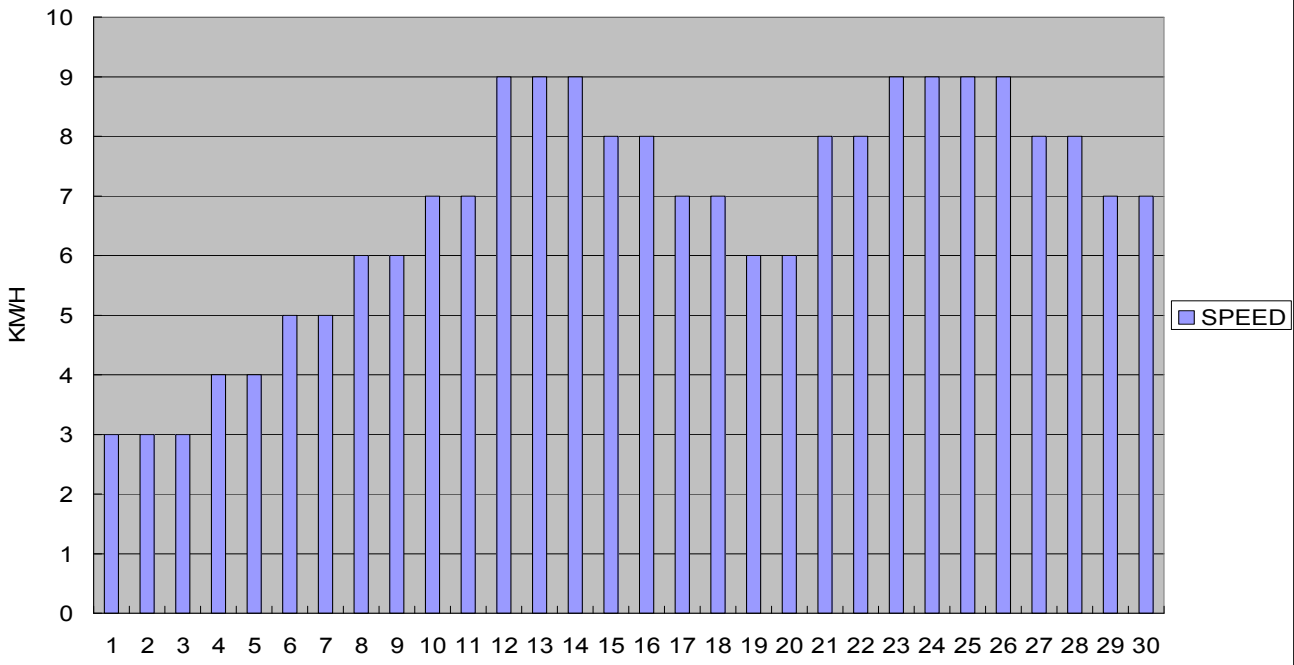

Program9

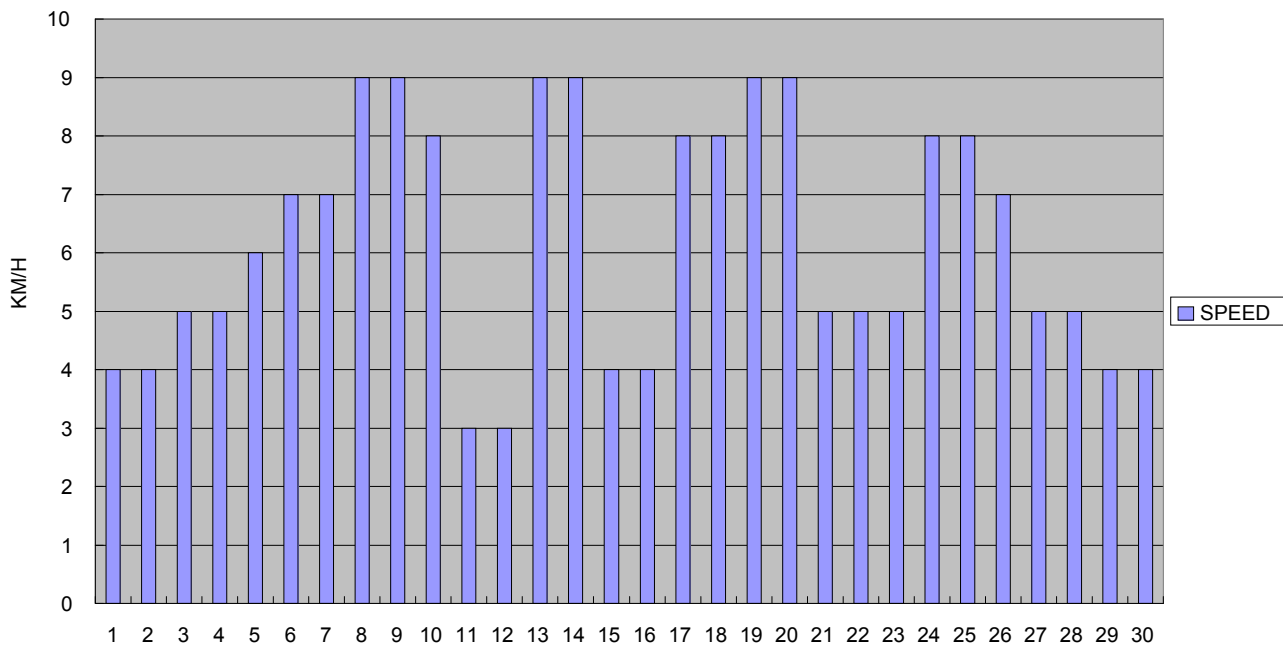

Program 10

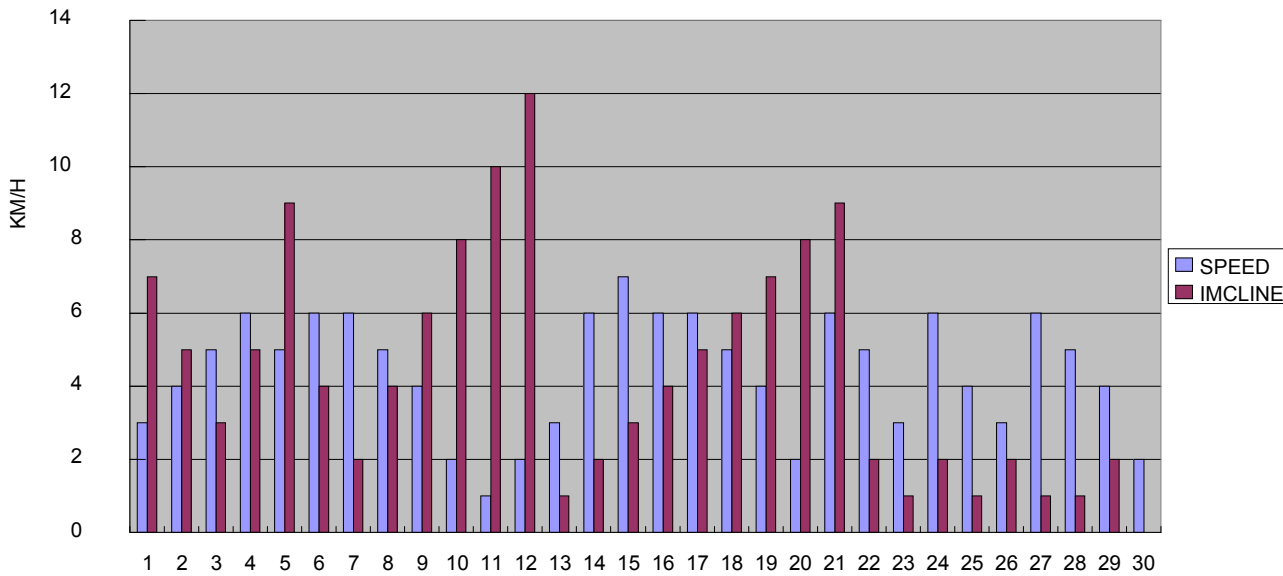

Program 11

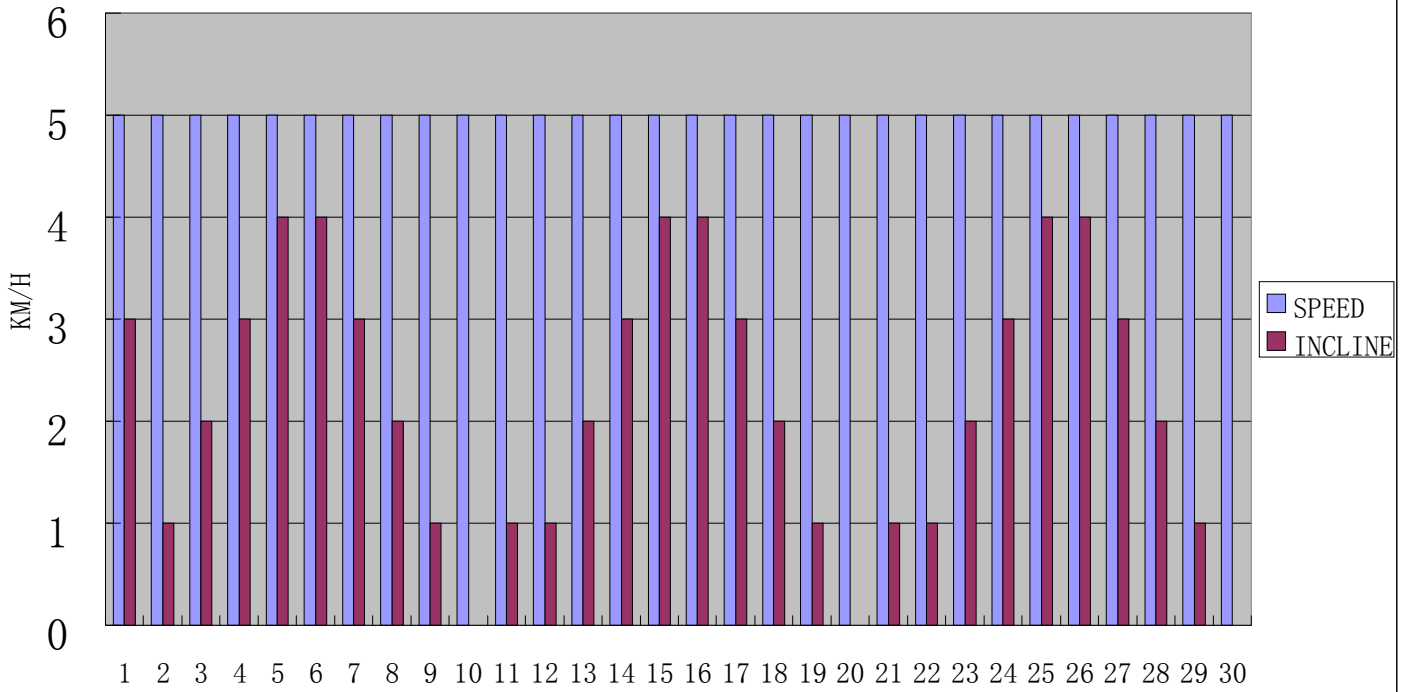

Program 12

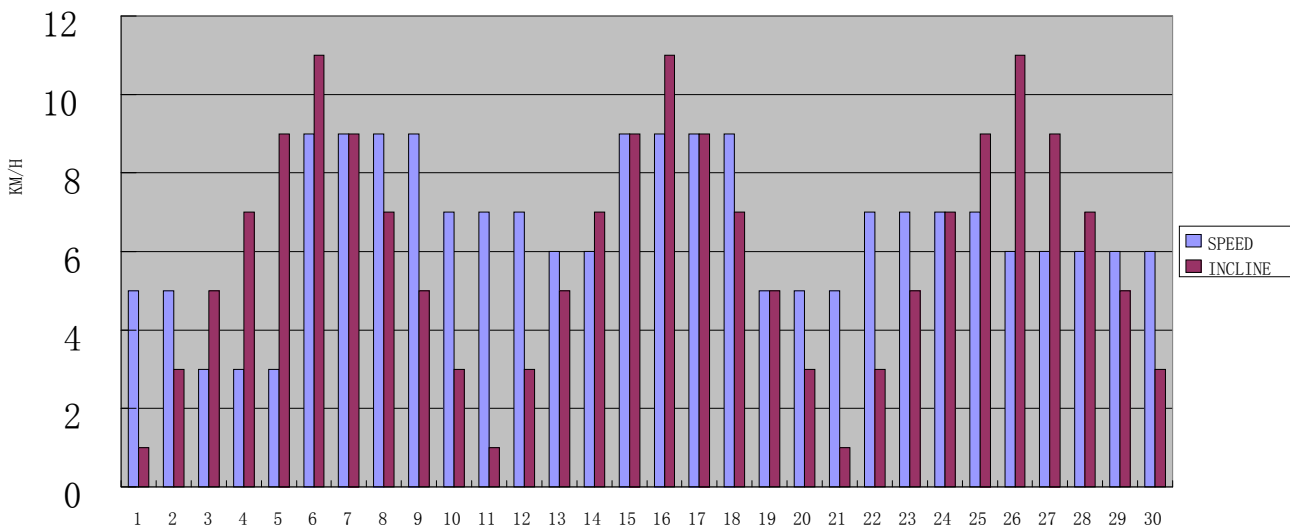

## 5. MAINTENANCE

Reasonable cleaning/lubricating should be made to extend the life time of this unit. Performance is maximized when the belt and mat are kept as clean as possible.

**WARNING: THE MAT/DECK FRICTION MAY PLAY A MAJOR ROLE IN THE FUNCTION AND LIFE OF YOUR TREADMILL AND THAT IS WHY WE RECOMMEND YOU CONSTANTLY LUBRICATE THIS FRICTION POINT TO PROLONG THE USEFUL LIFE OF YOUR TREADMILL. FAILING TO DO THIS MAY VOID YOUR WARRANTY.**

**WARNING: UNPLUG POWER CORD BEFORE MAINTENANCE.**

**WARNING: STOP TREADMILL BEFORE FOLDING.**

### 5.1 Maintenance and servicing

#### *AFTER EACH USE (DAILY)*

Clean and inspect, following these steps:

- Turn off the treadmill with the on/off switch, then unplug the power cord at the wall outlet.
- Wipe down the running belt, deck, motor cover, and console casing with a damp cloth. Never use solvents, as they can cause damage to the treadmill.
- Inspect the power cord. If the power cord is damaged, contact Lifespan Fitness.
- Make sure the power cord is not underneath the treadmill or in any other area where it can become pinched or cut.
- Check the tension and alignment of the running belt. Make sure that the treadmill belt will not damage any other components on the treadmill by being misaligned.

#### *EVERY WEEK*

Clean underneath the treadmill, following these steps:

- Turn off the treadmill with the on/off switch, then unplug the power cord at the wall outlet.
- Fold the treadmill into the upright position, making sure that the lock latch is secure.
- Move the treadmill to a remote location.
- Wipe or vacuum any dust particles or other objects that may have accumulated underneath the treadmill.
- Return the treadmill to its previous position.

### **EVERY MONTH -IMPORTANT!**

- Inspect all assembly bolts of the machine for proper tightness.
- Turn off the treadmill with the on/off switch, then unplug the power cord and wait 60 seconds.
- Remove the motor cover. Wait until ALL LED lights turn off.
- Clean the motor and lower board area to eliminate any lint or dust particles that may have accumulated. Failure to do so may result in premature failure of key electrical components.

### **EVERY 6 MONTHS**

It may be necessary to lubricate your treadmill running deck at least once every six months to maintain optimal performance of your treadmill (refer to section 4.4 for information). Only use lubricant provided by Lifespan Fitness! Please contact Lifespan Fitness with questions about applying lubricant to your treadmill.

- Turn off the treadmill with the on/off switch, then unplug the power cord at the wall outlet.
- Loosen both the rear roller bolts. (For best results, place two removable marks on both sides of the frame and note roller position). Once the belt is loosened, take the bottle of lubricant and apply it to the entire top surface of the running deck. Tighten both rear roller bolts (matching up the marks for proper position) to original position. After you have applied lubricant, plug in the power cord, key, start the treadmill and walk on the belt for two minutes to spread the lubricant.
- Lubricate the air shocks with Teflon based spray.

### **EVERY 2 YEARS**

It is necessary that you change your treadmill motor brushes once every 2 years to avoid damaging your motor. If you fail to change the brushes this may cause the motor to burn out, voiding any warranty.

**PLEASE NOTE: TREADMILL MOTOR BRUSHES NEED TO BE CHANGED EVERY 2 YEARS OTHERWISE MOTOR WARRANTY WILL BE VOID.REFER TO MANUAL**

**SERVICING: IF YOU FAIL TO COMPLY WITH LIFESPAN'S MAINTENANCE AND SERVICING STEPS ABOVE, YOU MAY VOID YOUR WARRANTY. IF YOU REQUIRE A SKILLED LIFESPAN REPRESENTATIVE TO UNDERTAKE ONE OF THE STEPS ABOVE, PLEASE EMAIL US AT [lifespanfitness@hotmail.com](mailto:lifespanfitness@hotmail.com).**

## **5.2 General Cleaning**

- Use a soft, damp cloth to wipe the edge of the belt and the area between the belt edge and frame. A mild soap and water solution along with a nylon scrub brush will clean the top of the textured belt. This task should be done once a month. Allow to dry before using.

- On a monthly basis, vacuum underneath your treadmill to prevent dust build up. Once a year, you should remove the black motor shield and vacuum out dirt that may accumulate.

### **5.3 General Care**

- Check parts for wear before use.
- Always replace the mat if worn and any other defective parts.
- If in doubt do not use the treadmill and contact our helpline.

TAKE CARE TO PROTECT CARPETS AND FLOOR in case of leakages. This product is a machine that contains moving parts which have been greased / lubricated and could leak.

### **5.4 Belt/Deck/Roller Lubrication**

The mat/deck friction may play a major role in the function and life of your treadmill and that is why we recommend you constantly lubricate this friction point to prolong the useful life of your treadmill.

You should apply the lubrication after approximately the first 40 hours of operation. We recommend lubrication of the deck according to the following timetable:

Light use (less than 3 hours per week) every 6 months

Medium use (3-5 hours a week) every 3 months

Heavy use (more than 5 hours per week) every 6-8 weeks.

See below procedures for lubricating:

1. Use a soft, dry cloth to wipe the area between the belt and deck.
2. Spread lubricant onto the inside surface of belt and deck evenly (make sure the machine is turned off and power is disconnected).
3. Periodically lubricate the front and rear rollers to keep them at their peak performance.

If the treadmill belt/deck/roller is kept reasonably clean it is possible to expect over 1200 hours before additional re-lubing is necessary.

### **5.5 How to check the running mat for proper lubrication**

1. Disconnect the main power supply.
2. Fold the treadmill up into the storage position.
3. Feel the back surface of the running mat.

If the surface is slick when touched, then no further lubrication is needed.

If the surface is dry to the touch, apply a suitable silicone lubricant.

**We recommend you use a silicone based spray to lubricate your Lifespan Treadmill. This Can be purchased from your local sports Retailer or a local hardware store.**

## 5.5 Belt Adjustment

Belt Tension Adjustment-It is very important for joggers and runners in order to provide a smooth, steady running surface. Adjustment must be made from the right and left rear roller in order to adjust tension with the Hexagonal Wrench provided in the parts package.

The adjustment bolt is located at the end of the rails as noted in diagram below:

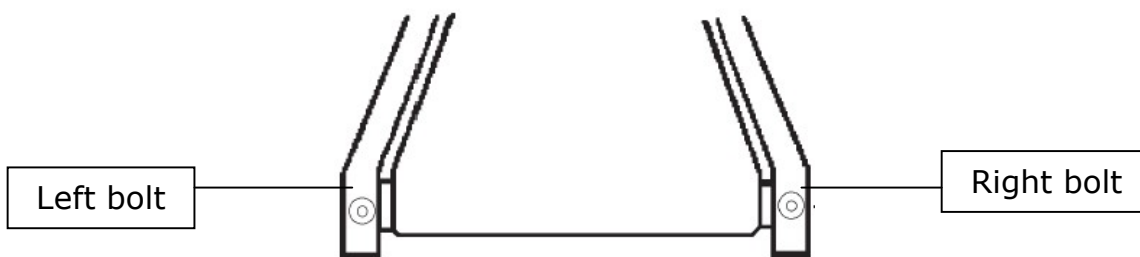

**Note: Adjustment is thru the small hold on the end caps.**

Tighten the rear roller only enough to prevent slippage at the front roller. Turn both the right and left bolt clockwise reasonably and inspect for proper tension. When an adjustment is made to the belt tension, you must also make a tracking adjustment to compensate for the change in belt tension.

**DO NOT OVERTIGHTEN** - Over tightening will cause belt damage and premature bearing failure.

## 5.6 Belt Tracking Adjustment

This treadmill is designed to keep the belt reasonably centred while in use. It is normal for some belts to drift near one side while the belt is running with no one on it. After a

few minutes of use, the belt should have a tendency to centre itself. If during use, the belt continues to move toward one side, adjustments are necessary. The procedures are as below:

- ▲ First set speed at lowest position.
- ▲ Second check the belt shifts to which side.

If the belt shifts to right, tighten the right bolt and loosen the left bolt by using 6mm Hexagonal Wrench, until the belt is centered itself; If belt shifts to left, tighten the left bolt and loosen the right bolt by using 6mm Hexagonal Wrench, until the belt is centered. When adjusting the belt using the 6 mm Hexagonal Wrenches, it is important to adjust the belt in half turn increments. Over adjusting the belt can cause damage to the mat.

## 6. TROUBLE SHOOTING

This treadmill is designed in a way that in the event of an electrical fault, the machine will turn off automatically to prevent any injuries to the user and to prevent damage to the machine (i.e. motor).

When the treadmill behaves erratically, simply reset the treadmill by turning the power switch off, waiting for 1 minute then turning the power button back on.

If, after you have reset the treadmill, it is still not running correctly, please run the self-checking analyse (please refer to **4.3 Self-Checking**) to distinguish what type of error

**Before attempting any work on the treadmill, ensure that the power is off and the plug is removed from the power point.**

**Do not use extension leads as it may lead to power decrease and failure.**

problem the machine is encountering.

### 6.1 Alarm signals

#### E1: No feedback from controller or speed sensor

1. Check the condition of cables and ensure that all plugs are connected between the motor controller and display.
2. Check that the speed sensor and magnet are in correct alignment and that there are no obstructions on the magnet. (The magnet can be found on the front roller near the motor belt).



3. If the running belt moves then displays the E1 error replace the speed sensor.
4. If the running belt does not move replace the controller.

#### **E2: Controller problem**

1. Replace the controller
2. Check the wire connection

#### **E3: Over speed protection. (Sudden increase of running belt speed).**

1. Check the speed sensor and magnet are in correct alignment and that there are no obstructions on the magnet.
2. Check wire connections on the controller.
3. Replace the speed sensor.
4. Replace the controller.

#### **E4: Incline fault**

1. Replace incline motor.
2. If problem remains replace controller.

**When alarm signals are displayed, single press 'CLEAR' to reset the displays and try again.**

#### **No Power**

1. Check fuses (They are located on the controller under the motor cover next to the on/off switch).
2. Check power outlet (Plug something else into the power outlet to ensure that the power outlet is working correctly).
3. Check Power Cable (You may need to take it to an electrician).

## **7. EXERCISE GUIDE**

**PLEASE NOTE: Before beginning any exercise program, consult you physician. This is important especially if you are over the age of 45 or individuals with pre-existing health problems.**

**The pulse sensors are not medical devices. Various factors, including the user's movement, may affect the accuracy of heart rate readings. The pulse sensors are intended only as an exercise aid in determining heart rate trends in general.**

Exercising is great way to control your weight, improving your fitness and reduce the effect of aging and stress. The key to success is to make exercise a regular and enjoyable part of your everyday life.

The condition of your heart and lungs and how efficient they are in delivering oxygen via your blood to your muscles is an important factor to your fitness. Your muscles use this oxygen to provide enough energy for daily activity. This is called aerobic activity. When you are fit, your heart will not have to work so hard. It will pump a lot fewer times per minute, reducing the wear and tear of your heart.

So as you can see, the fitter you are, the healthier and greater you will feel.

## 8.SPARE PARTS LIST

<b>Packing List</b>			
<b>Item no.</b>	<b>Description</b>	<b>Unit</b>	<b>Quantity</b>
1	Safety Key	piece	1
2	Screw M8X16	piece	2
3	Screw M10X16	piece	2
4	Screw M10X60	piece	2
5	Screw M5X16	piece	2
6	Plain washer $\phi$ 8	piece	4
7	Dentate washer $\phi$ 10	piece	2
8	Screw M8X60	piece	2
9	6mm wrench	piece	1
10	5mm wrench	piece	1
11	wrench 14X17	piece	1
12	Rail	piece	1

13	Mp3 wire	piece	1
14	Manual	piece	1
15	Water holder	piece	1

## 9. INSTALLATION GUIDE

## INSTALLATION GUIDE

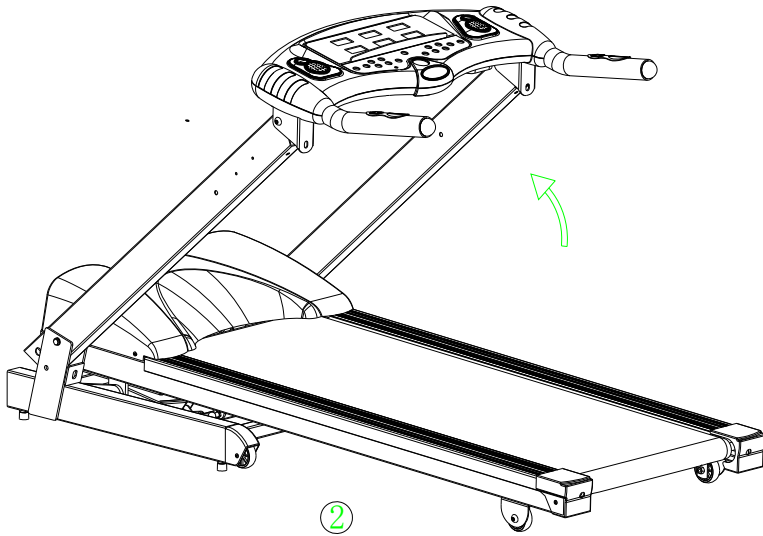
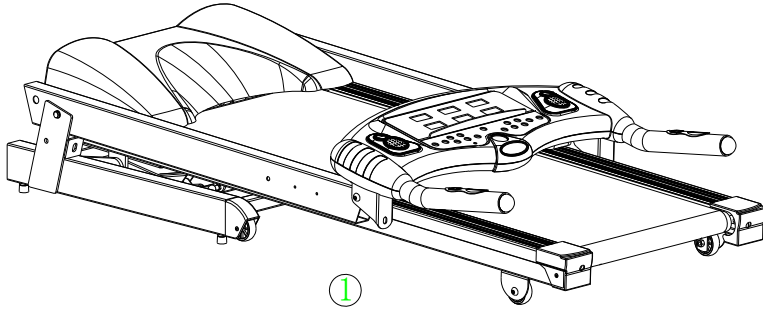

## INSTALLATION GUIDE

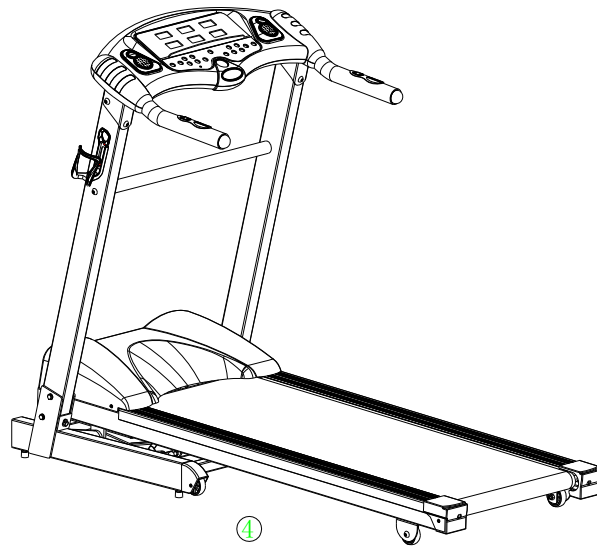
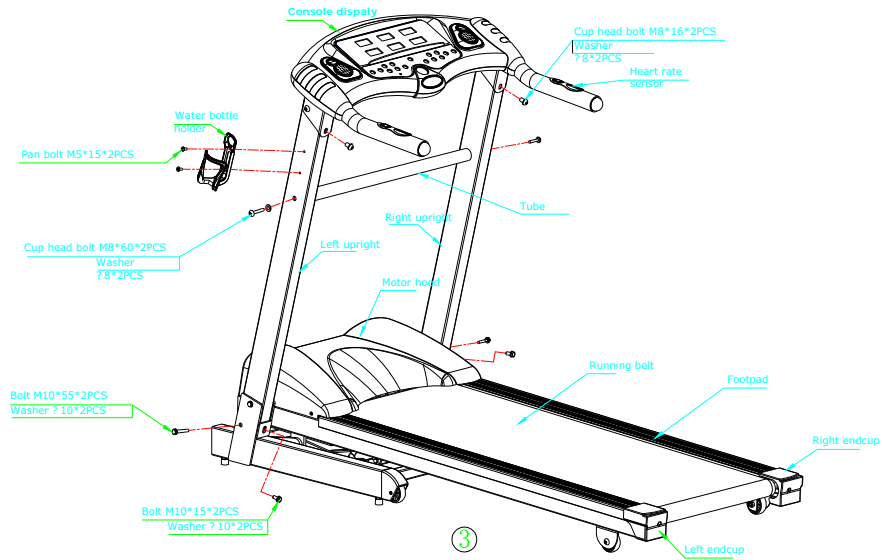

We have checked the words carefully in the manual. If there is something wrong in printing, please kindly consider it.

If the pictures are different from the product, please take the product as the final and correct one.

Please note: If there are changes in function and specification due to technical improvement, we will not keep you informed.

## **10. WARRANTY REGISTRATION**

Please visit the following link to complete the product warranty form online. Please visit <http://warrantyform.lifespanfitness.com.au/>

**PLEASE NOTE: YOUR WARRANTY IS ONLY VALID IF YOU CAN PROVE YOU ARE THE ORIGINAL PURCHASER ON THIS ITEM (i.e. a copy of the receipt, invoice, delivery date or internet confirmation).**