

Centennia TD

Diode-Pumped, CW Visible Thin-Disk Laser System

User's Manual

This laser product complies with performance standards of United States Code of Federal Regulations, Title 21, Chapter 1 - Food and Drug Administration, Department of Health and Human Services, Subchapter J - Parts 1040.10 (a), (1) or (2), as applicable.

 Spectra-Physics

A Division of Newport Corporation

1335 Terra Bella Avenue
Mountain View, CA 94043

Part Number 0000-346A, Rev. A
November 2005

Preface

This manual contains information you need in order to safely install, operate, maintain and troubleshoot your *Centennia TD* diode-pumped, continuous-wave visible laser. The system is composed of the *Centennia TD* laser head and the *Centennia* power supply. The laser head is water cooled, and an optional chiller is available to supply the specified water flow.

Chapter 1 “Introduction” is an overview of the *Centennia TD* system.

Chapter 2 “Laser Safety” is an important chapter on laser safety. The *Centennia TD* is a Class IV laser and, as such, emits laser radiation which can cause severe damage to eyes and skin. This section contains information about these hazards and offers suggestions on how to safeguard against them. To minimize the risk of injury, be sure to read this chapter—then carefully follow its instructions.

Chapter 3 “Laser Description” contains a short section on laser theory, particularly regarding the thin-disk laser technology, the Nd:YVO₄ laser material, and the nonlinear optical frequency doubling employed by the *Centennia TD* to produce its green output beam. The theoretical discussion is followed by a more detailed description of the *Centennia TD* system itself. The chapter concludes with specifications and outline drawings.

Chapter 4, “Controls, Indicators, and Connections” and Chapter 5, “Installation,” describe the *Centennia TD* connections and controls, then guide you through the installation of the system.

Chapter 6 “Operation” describes how to operate the laser using the controls and LCD display on the front panel of the *Centennia* power supply.

Chapter 7 “Maintenance and Troubleshooting” will help you to guide your Spectra-Physics field service engineer to the source of any problems. *Do not attempt repairs yourself while the unit is still under warranty*; instead, report all problems to Spectra-Physics for warranty repair.

Chapter 8 “Customer Service” gives information on service calls and warranty issues. Should you experience any problems with any equipment purchased from Spectra-Physics, this chapter contains a list of world-wide Spectra-Physics service centers you can call if you need help.

This product has been tested and found to conform to Directive 73/23/EEC governing product safety using standards EN 61010-1: 2001 and EN 60825-1: 2002, and it conforms to Directive 89/336/EEC governing electromagnetic compatibility using standard EN 61326-1 w/ A1, A2, A3: 1997 as listed in the official *Journal of the European Communities*. Refer to the statements in “CE Declaration of Conformity” on page 2-13.

Every effort has been made to ensure that the information in this manual is accurate. All information in this document is subject to change without notice. Spectra-Physics makes no representation or warranty, either expressed or implied, with respect to this document. In no event will Spectra-Physics be liable for any direct, indirect, special, incidental or consequential damages resulting from any defects in this documentation.

Finally, if you encounter any difficulty with the content or style of this manual, or encounter problems with the laser itself, please let us know. The last page of this manual is a form to aid in bringing such problems to our attention.

Thank you for your purchase of Spectra-Physics instruments.

Environmental Specifications

CE Electrical Equipment Requirements

For information regarding the equipment needed to provide the electrical service listed in “Specifications” on page 3-11, please refer to specification EN-309, “Plug, Outlet and Socket Couplers for Industrial Uses,” listed in the official *Journal of the European Communities*.

Environmental Specifications

The environmental conditions under which the laser system will function are listed here:

Indoor use

Altitude:	up to 3000 m
Temperatures:	18°C to 35°C
Relative humidity:	8% to 85% non-condensing over specified temperature range
Mains supply voltage:	do not exceed $\pm 10\%$ of the nominal voltage
Insulation category:	II
Pollution degree:	2

FCC Regulations

This equipment has been tested and found to comply with the limits for a Class A digital device pursuant to Part 15 of the FCC Rules. These limits are designed to provide reasonable protection against harmful interference when the equipment is operated in a commercial environment. This equipment generates, uses and can radiate radio frequency energy and, if not installed and used in accordance with the instruction manual, may cause harmful interference to radio communications. Operation of this equipment in a residential area is likely to cause harmful interference in which case the user will be required to correct the interference at his own expense.

Modifications to the laser system not expressly approved by Spectra-Physics could void your right to operate the equipment.

CDRH and UL Regulations

This product conforms to the requirements of 21 CFR 1040.10 CDRH. In addition, it has been designed and tested to comply with Underwriters Laboratory UL60950 Ed.3 and it conforms to the requirements of UL recognized components.

Table of Contents

- Preface iii**
- Environmental Specifications. v**
 - CE Electrical Equipment Requirements v
 - Environmental Specifications v
 - FCC Regulations v
 - CDRH and UL Regulations v
- Warning Conventions xi**
- Abbreviations xiii**
- Standard Units xv**
- Unpacking and Inspection xvii**
 - Unpacking Your Laser xvii
 - System Components xvii
 - Accessories xviii
- Chapter 1: Introduction 1-1**
 - The Centennia TD 1-1
 - The Laser System 1-2
 - Laser Head 1-2
 - Power Supply 1-2
 - System Control 1-3
 - Chiller 1-3
 - Patents 1-3
- Chapter 2: Laser Safety. 2-1**
 - Hazards 2-1
 - Precautions For The Safe Operation Of Class IV High Power Lasers 2-2
 - Maximum Emission Levels and Protective Eye Wear 2-3
 - Safety Devices 2-5
 - On/Off AC Power Switch 2-5
 - AC Power Indicator 2-5
 - Laser Enable Keyswitch 2-5
 - Ready Indicator 2-5
 - Start Button 2-5
 - Laser Emission Indicators 2-6
 - Power Adjustment Dial 2-7
 - Error Indicator 2-7
 - Stop Button 2-7
 - Shutter 2-7
 - External Interlocks 2-7
 - Waste Electrical and Electronic Equipment Recycling Label 2-8
 - CDRH Requirements for Operating the Centennia TD 2-9
 - Maintenance Necessary to Keep this Laser Product in Compliance with CDRH Regulations 2-9

CDRH Radiation Control Drawing2-10
CE/CDRH Warning Labels2-11
 Label Translations2-12
CE Declaration of Conformity2-13
Sources for Additional Information2-14
 Laser Safety Standards2-14
 Equipment and Training2-15

Chapter 3: Laser Description 3-1

A Brief Review of Laser Theory3-1
 Emission and Absorption of Light3-1
 Population Inversion3-2
 Resonant Optical Cavity3-3
 Nd3+ as a Laser Medium3-4
 Diode-Pumped Laser Design3-5
 Thin-Disk Laser Technology3-6
 Frequency Doubling3-7
The Centennia TD System3-8
 The Centennia TD Laser Head3-8
 The Centennia Power Supply3-10
System Control3-10
Specifications3-11
Outline Drawings3-13

Chapter 4: Controls, Indicators and Connections 4-1

The Centennia TD Laser Head4-1
 Controls4-1
 Indicators4-1
 Legs4-2
 Connections4-2
Centennia Power Supply4-2
 Power Supply Front Panel4-2
 Power Supply Rear Panel4-4
Connector Interface Descriptions4-5
 Serial COM Connector4-5
 EMISSION Connector4-5
 Safety INTERLOCK Connector4-6

Chapter 5: Installation. 5-1

Installing the Laser Head5-1
Installing the Power Supply5-2
 Mounting the Power Supply as a Stand-Alone Unit5-3
 Mounting the Power Supply in a Standard Rack5-3
Installing the Chiller5-3
Connecting the System5-4
Moving the System5-5
Alignment5-5

Chapter 6: Operation. 6-1

System Startup and Shutdown6-1
 Turning the Laser On6-1
 Turning the Laser Off6-3

Chapter 7: Maintenance and Troubleshooting 7-1

Maintenance	7-1
Troubleshooting	7-2
Service Training Programs	7-2
Troubleshooting Guide	7-2

Chapter 8: Customer Service 8-1

Customer Service	8-1
Warranty	8-1
Returning the Instrument for Repair	8-2
Removing Water from the System	8-2
Service Centers	8-3

Notes**Report Form for Problems and Solutions****List of Figures**

Figure 1-1: The Centennia TD System	1-1
Figure 2-1: CE and CDRH standard safety warning labels	2-2
Figure 2-2: Folded Metal Beam Target	2-2
Figure 2-3: Power Supply Front Panel	2-4
Figure 2-4: Power Supply Rear Panel	2-4
Figure 2-5: Centennia TD Laser Head Emission Indicators	2-6
Figure 2-6: Emission Connector Schematic	2-6
Figure 2-7: Interlock Jumper Plug	2-7
Figure 2-8: CDRH Radiation Control Drawing	2-10
Figure 2-9: CE/CDRH Warning Labels	2-11
Figure 3-1: Electrons occupy distinct orbitals	3-2
Figure 3-2: A Typical Four-level Transition Scheme	3-3
Figure 3-3: Energy Level Scheme for the Nd ³⁺ Ion	3-4
Figure 3-4: Nd ³⁺ absorption spectra	3-5
Figure 3-5: Thin-Disk Laser Cavity	3-6
Figure 3-1: Centennia TD System (chiller not shown)	3-8
Figure 3-2: Optical Layout of the Centennia TD Laser Head	3-9
Figure 3-3: Outline Drawings for Laser Head and Power Supply	3-13
Figure 4-1: Centennia TD Laser Head	4-1
Figure 4-2: Centennia Power Supply Front Panel	4-2
Figure 4-3: Centennia Power Supply Rear Panel	4-4
Figure 4-4: Interlock Jumper Plug	4-5
Figure 4-5: Emission Connector Circuit	4-6
Figure 5-1: Base Slots for Mounting Clamps	5-1
Figure 5-2: Location of leg mounting holes on bottom of laser head	5-2
Figure 5-3: Centennia TD Interconnect Drawing	5-4
Figure 5-4: Power Supply Rear Panel	5-4

List of Tables

Table 2-1 : Label Translations.	2-12
Table 3-1: Centennia TD Laser Output Characteristics	3-11
Table 3-2: Utilities	3-11
Table 3-3: Fuse Ratings for F1 and F2	3-11
Table 3-4: Dimensions and Weight	3-12
Table 3-5: Chiller Requirements	3-12

Warning Conventions

The following warnings are used throughout this manual to draw your attention to situations or procedures of particular importance. They warn of hazards to health and safety, damage to equipment, sensitive procedures, and exceptional circumstances. All messages are set apart by a thin line above and below the text as shown here.



Laser radiation is present.

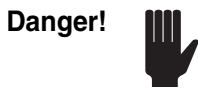

Condition or action may present a hazard to personal safety.



Condition or action may present an electrical hazard to personal safety.

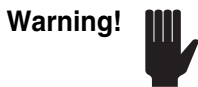

Condition or action may cause damage to equipment.

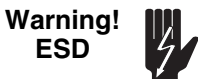

Action may cause electrostatic discharge and cause damage to equipment.



Condition or action may cause poor performance or error.



Text describes exceptional circumstances or makes a special reference.



Do not touch.



Appropriate laser safety eyewear should be worn during this operation.



Refer to the enclosed documents and manual before operating or using this device.

Abbreviations

These abbreviations may be found in this manual:

AC	alternating current
AOM	acousto-optic modulator
AR	antireflection
CDRH	Center of Devices and Radiological Health
CW	continuous wave
DC	direct current
E/O	electro-optic
fs	femtosecond or 10^{-15} second
HR	high reflector
IR	infrared
OC	output coupler
ps	picosecond or 10^{-12} second
PZT	piezo-electric transducer
RF	radio frequency
SCFH	standard cubic feet per hour
TEM	transverse electromagnetic mode
Ti:sapphire	Titanium-doped Sapphire
UV	ultraviolet
λ	wavelength

Standard Units

The following units, abbreviations, and prefixes are used in this Spectra-Physics manual:

Quantity	Unit	Abbreviation
mass	kilogram	kg
length	meter	m
time	second	s
frequency	hertz	Hz
force	newton	N
energy	joule	J
power	watt	W
electric current	ampere	A
electric charge	coulomb	C
electric potential	volt	V
resistance	ohm	Ω
inductance	henry	H
magnetic flux	weber	Wb
magnetic flux density	tesla	T
luminous intensity	candela	cd
temperature	Celsius	C
pressure	pascal	Pa
capacitance	farad	F
angle	radian	rad

Prefixes								
tera	(10^{12})	T	deci	(10^{-1})	d	nano	(10^{-9})	n
giga	(10^9)	G	centi	(10^{-2})	c	pico	(10^{-12})	p
mega	(10^6)	M	milli	(10^{-3})	m	femto	(10^{-15})	f
kilo	(10^3)	k	micro	(10^{-6})	μ	atto	(10^{-18})	a

Unpacking and Inspection

Unpacking Your Laser

Your *Centennia TD* laser system was packed with great care, and its container was inspected prior to shipment—it left Spectra-Physics in good condition. Upon receiving your system, immediately inspect the outside of the shipping crate. If there is any significant damage (holes in the crate, for example), insist that a representative of the carrier be present when you unpack the contents.

When you open the crate, notify the carrier immediately if damage is apparent to the interior boxes. Carefully inspect your laser system as you unpack it. If you see any dents or scratches on the covers or so forth, immediately notify the carrier and your Spectra-Physics representative.

Keep the shipping containers and packing materials. If you need to return the system for service at a later date, the specially designed containers assure adequate protection. Instruments can be returned only in Spectra-Physics containers.

The laser head arrives with the umbilical and water hoses attached. The laser head with umbilical weighs approximately 20 kg (44 lb); it will be safer if two people work together to handle the laser head. The power supply weighs about 8 kg (18 lb) and can be picked up by one person.

If only a small cart is available to move the system, the laser head can be placed on top of the power supply on the cart. Balance the laser head carefully as it is considerably longer and heavier than the power supply. If your system was shipped with a rack-mountable chiller, move it separately from the laser head and power supply.

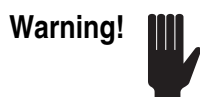

Be careful when moving the laser head that the umbilical does not snag and pull the laser head from the cart.

System Components

The *Centennia TD* laser system comprises these components:

- *Centennia TD* laser head with umbilical
- *Centennia* power supply

The *Centennia TD* laser head is water-cooled. An optional rack-mountable recirculating chiller is available for supplying the specified water flow.

Verify that all components are present. The laser head and power supply are shipped in one container; the chiller if included is shipped in its own crate.

Accessories

Included with the laser system is this manual, a packing slip listing all the parts shipped, the *Centennia TD* Test Summary (the “Ship Report”), and an accessory kit. The following accessories are shipped standard with the system:

- 1 US and 1 European power cord (about 2 m)
- Table clamp kit:
3 clamps, 3 pairs of nested spherical washers, 3 mounting screws
- 13 mm wrench
- 2 keys for the power supply
- 2 10A fuses
- An INTERLOCK jumper plug

The Centennia TD

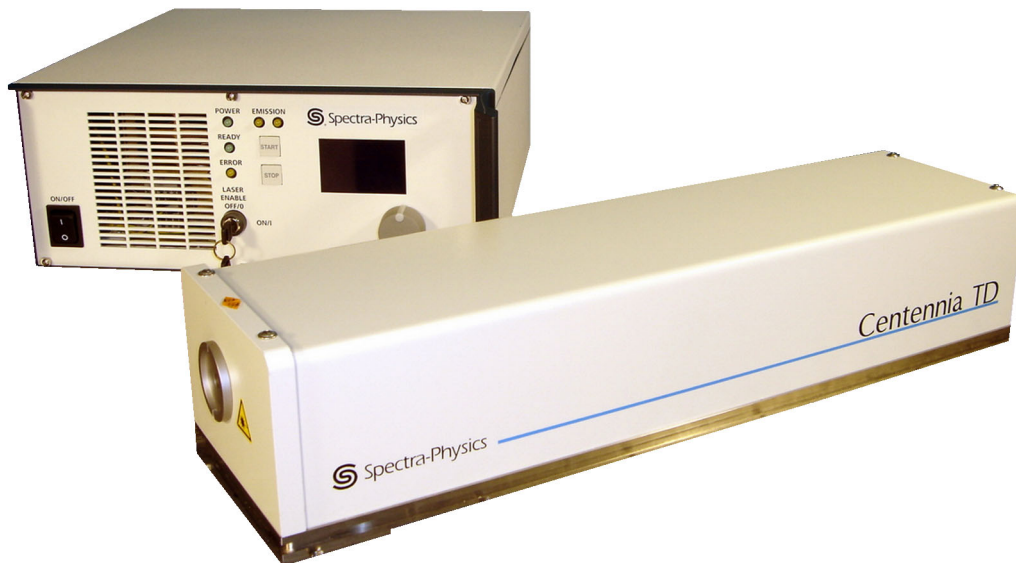

Figure 1-1: The Centennia TD System

The Spectra-Physics *Centennia TD*[™] is an innovative, cost-effective system that produces a continuous green laser beam, generating more than 5 Watts of laser power at a wavelength of 532 nm. Machined from a solid aluminum block, the *Centennia TD* sealed laser head features a rugged industrial design and simple, hands-off operation.

The *Centennia TD* employs thin disk technology, a novel approach to the problems of thermal management of solid state laser materials. The fundamental laser action in the *Centennia TD* is produced by exciting or “pumping” a thin disk of vanadate crystalline material with the output of a high-power diode laser. The infrared output of the diode-pumped vanadate disk is then converted to the green *Centennia TD* output beam through the non-linear optical phenomenon of frequency doubling.

The use of thin disk technology results in a laser architecture that is simpler, more efficient, and lower cost than conventional diode-pumped lasers, yet still produces a high-quality beam suitable for printing and graphical applications, for pumping other lasers, and many other scientific and industrial uses as well.

The Laser System

The *Centennia TD* system comprises these components:

- *Centennia TD* laser head with umbilical
- *Centennia* air-cooled power supply

The *Centennia TD* laser head is water-cooled. An optional recirculating chiller is available for supplying the specified water flow.

Laser Head

The *Centennia TD* laser head includes the sealed laser cavity, the shutter, the emission indicators, and the umbilical, which is permanently-attached and supplies electrical power and control from the power supply. The sealed laser cavity encloses the optical resonator, which contains the neodymium yttrium vanadate (Nd:YVO₄) laser thin disk, and the diode pump laser and lithium triborate (LBO) doubling crystal.

The fundamental infrared beam produced by the vanadate disk is focused into a nonlinear crystal of LBO that generates the green output beam at 532 nm. The LBO crystal is housed in an oven assembly that maintains the crystal at the optimum temperature for the frequency-doubling process. The green beam exits through a dichroic output mirror that confines virtually all of the infrared light inside the resonator.

An internal control system employs thermo-electric coolers to stabilize the temperatures of the diode pump laser and the LBO assembly at their optimum value. The laser head must be cooled by a constant-temperature water flow to remove excess heat from the unit.

A telescope system adjusts the output beam to its specified dimensions before it exits the laser head, and a light pick-off samples a portion of the beam as part of the power control loop. The shutter, which is opened and closed via electronic command, provides a safe mechanical means to block the output beam. The shutter default position is closed.

Power Supply

The all solid-state *Centennia* power supply contains the control logic and power modules for the system. The unit is compact and designed for table-top placement. All operation and monitoring of laser functions is provided by controls and indicators on the front panel. The power supply is air cooled and requires no water or external cooling connections. The power supply is auto-ranging and operates from a standard 50 or 60Hz electrical utility from 100 to 240 Vac.



Caution!



Neither the power supply nor the laser head of the *Centennia TD* system contain user serviceable parts. The laser head in particular has been assembled in a clean, controlled environment; the sealed inner cavity is filled with an inert gas. *Removing the outer covers from either the laser head or power supply will void the warranty.*

System Control

Operating the laser is straightforward using the controls and LCD screen on the front panel of the *Centennia* power supply. Emission indicators on the laser head and power supply blink to warn that laser emission is imminent, and then glow steadily when the laser beam is present. The LCD screen displays both the requested power output and the measured output of the laser as determined by the power control loop. LEDs also indicate the readiness of the system for operation or the activation of a system interlock. Electrical power and control is transmitted through the umbilical that connects the laser head to the power supply.

Chiller

The *Centennia TD* laser head is water cooled, and an optional recirculating chiller is available that meets the cooling requirements of the system. This chiller displays the temperature of the cooling fluid water on the front panel for easy monitoring. Because the *Centennia TD* system is designed for recirculating cooling, it requires no facility water connections.

Patents

The *Centennia TD* system is manufactured under the following patents:

DE 59 407 111	DE 19 746 835	EP 0 911 920
EP 0 632 551	WO 2001 1 022541	US 6.711.184
EP 0 869 591	DE 19 946 176	
EP 0 869 592	JP 2003 510821	
US 5.553.088	CA 2 351 409	

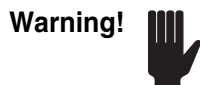

This user information is in compliance with section 1040.10 of the CDRH Laser Products Performance Standards from the Health and Safety Act of 1968. The use of controls or adjustments, or the performance of procedures other than those specified herein, may result in hazardous radiation exposure.



The Spectra-Physics *Centennia TD* laser is a *Class IV—High Power Laser* whose beam is, by definition, a safety and fire hazard. Take precautions to prevent accidental exposure to both direct and reflected beams. Diffuse as well as specular beam reflections can cause severe eye or skin damage.

This safety section should be reviewed thoroughly prior to operating the *Centennia TD* laser system, and the safety precautions listed herein should be followed carefully.

Hazards

Hazards associated with the use of diode-pumped lasers generally fall into the categories listed below. At all times while working with these lasers, please be aware of these potential hazards and act accordingly. You are responsible for your health and the health of those working around you.

- Exposure to laser radiation can result in damage to the eyes or skin.
- Exposure to chemical hazards, such as particulate matter or gaseous substances, can be health hazards when they are released as a result of laser material processing, or as by-products of the lasing process itself. When these lasers are used to pump dye laser systems, be aware that the dyes used can be extremely hazardous to your health if inhaled or, in some cases, touched.
- Exposure to high-voltage electrical circuits present in the laser power supply and associated circuits can result in shock or even death.
- Possible health risks are present if pressurized hoses, cylinders, liquids and gasses used in laser systems are damaged or misused.

Precautions For The Safe Operation Of Class IV High Power Lasers

- Wear protective eyewear at all times; selection depends on the wavelength and intensity of the radiation, the conditions of use, and the visual function required. Protective eyewear is available from suppliers listed in the *Laser Focus World*, *Lasers and Optronics*, and *Photonics Spectra* buyer's guides. Consult the ANSI and ACGIH standards listed at the end of this section for guidance.
- Maintain a high ambient light level in the laser operation area so the eye's pupil remains constricted, reducing the possibility of damage.
- To avoid unnecessary radiation exposure, keep the protective cover on the laser head at all times.
- Avoid looking at the output beam; even diffuse reflections are hazardous.
- Avoid blocking the output beam or its reflections with any part of the body.
- Establish a controlled access area for laser operation. Limit access to those trained in the principles of laser safety.
- Post prominent warning signs near the laser operating area (Figure 2-1).
- Set up experiments so the laser beam is either above or below eye level.
- Provide enclosures for beam paths whenever possible.
- Set up shields to prevent any unnecessary specular reflections.
- Set up a beam dump to capture the laser beam and prevent accidental exposure (Figure 2-2).

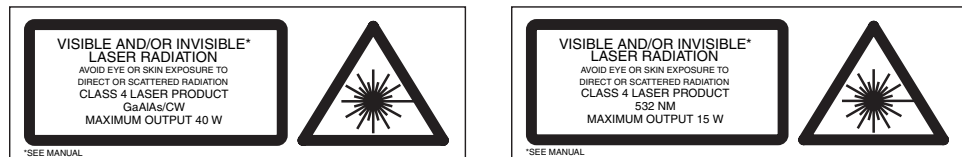

Figure 2-1: These CE and CDRH standard safety warning labels would be appropriate for use as entry warning signs (EN 60825-1, ANSI Z136.1 Section 4.7).

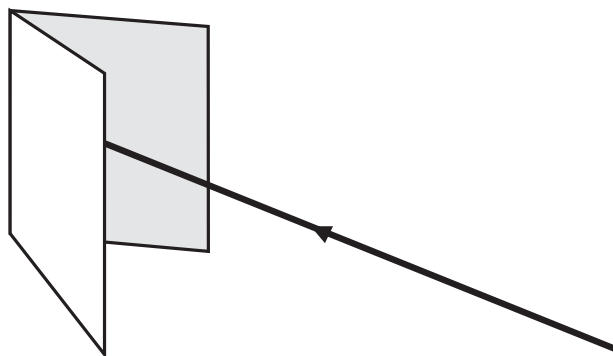

Figure 2-2: Folded Metal Beam Target

Danger!



Use of controls or adjustments, or the performance of procedures other than those specified herein, may result in hazardous radiation exposure.

Danger!



Operating this laser without due regard for these precautions or in a manner that does not comply with recommended procedures may be dangerous. At all times during installation, maintenance or service of your laser, avoid unnecessary exposure to laser or collateral radiation* that exceeds the accessible emission limits listed in “Performance Standards for Laser Products,” *United States Code of Federal Regulations*, 21CFR1040.10(d).

**Any electronic product radiation, except laser radiation, emitted by a laser product as a result of or necessary for the operation of a laser incorporated into that product.*

Follow the instructions contained in this manual to ensure proper installation and safe operation of your laser.

Maximum Emission Levels and Protective Eye Wear

It is recommended that laser-safe eye wear be worn at all times when the *Centennia TD* laser is on. The following are the maximum emission levels possible for this *Centennia TD* product. Use this information for selecting appropriate laser safety eyewear and implementing appropriate safety procedures. These values do not imply actual system power or specifications.

Emission Wavelength	Maximum Power
532 nm laser output wavelength (second harmonic)	6 W
1064 nm fundamental operation wavelength	< 10 mW

During normal operation, the operator will not be exposed either to hazardous diode laser or fundamental emission. However, removing the interior sealed laser head cover will not only invalidate the warranty, but will also expose the operator to hazardous levels of infrared and invisible laser radiation from both the diode pump laser and the fundamental vanadate output.

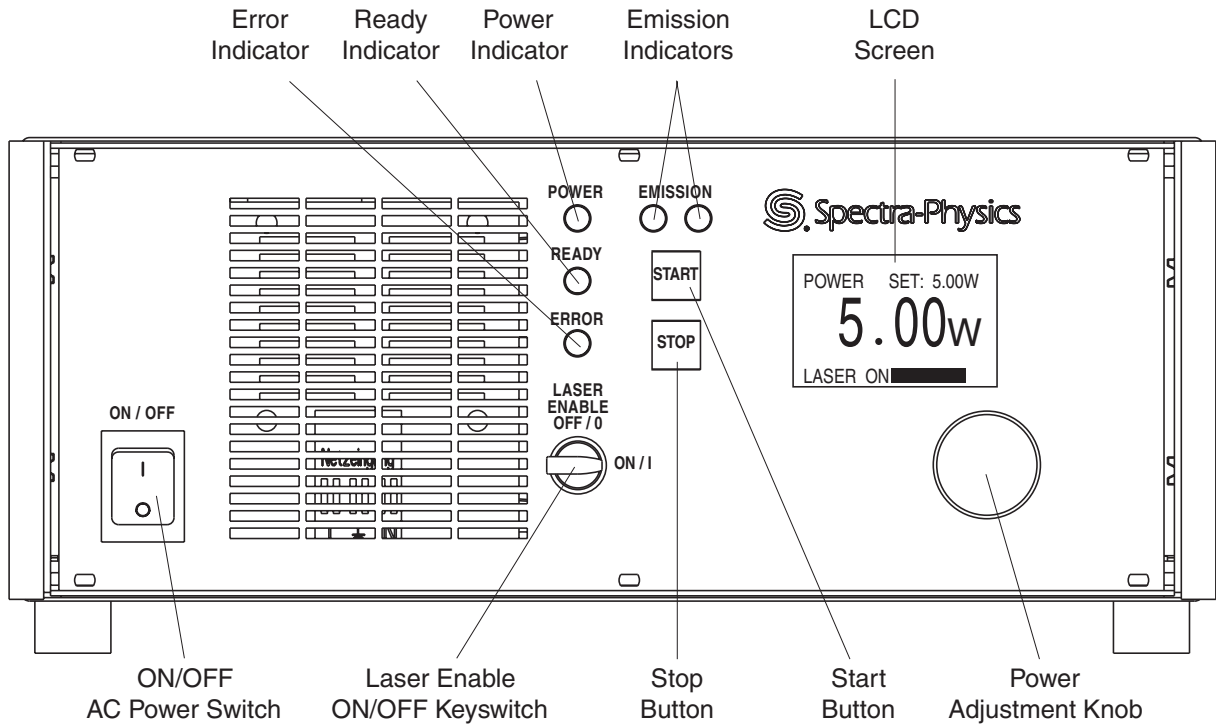

Figure 2-3: Power Supply Front Panel

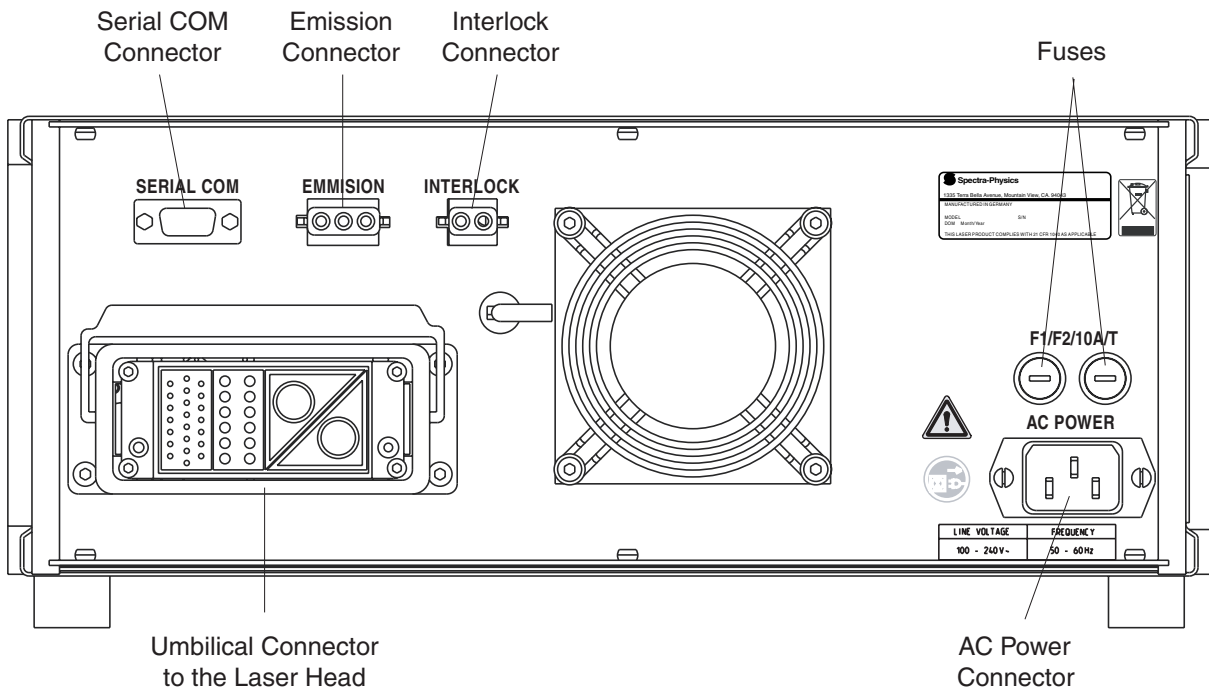

Figure 2-4: Power Supply Rear Panel

Safety Devices

Figure 2-3, Figure 2-4 and Figure 2-5 on the following pages show the locations of safety devices on the power supply and laser head.

On/Off AC Power Switch

Turning on the POWER rocker switch activates electrical power to the circuits in the power supply.

AC Power Indicator

The green POWER LED on the power supply illuminates when electrical power is provided to the power supply circuitry.

Laser Enable Keyswitch

Turning the LASER ENABLE keyswitch to the ON position starts the warm-up process that turns on the laser (if the AC power switch is turned on first). The keyswitch provides interlock safety to prevent unauthorized personnel from using the system when the key is turned to the OFF position and is then removed.

Danger!



A high level of laser radiation is temporarily present inside the laser when the start sequence is initiated, even if the power level is set to 0. This transient condition is part of the process that warms the laser to its proper operating temperature. Laser emission is blocked by the shutter. When the shutter is opened, laser emission will be at the selected power level. However personnel must always employ safety practices appropriate for the maximum rated output of the laser, including wearing approved safety glasses.

Ready Indicator

This green LED on the power supply blinks after the keyswitch is turned on to indicate that components in the laser head are warming to operating temperature. When the laser head is ready to operate, this indicator glows steadily. Laser emission is present inside of the laser head when the READY indicator is either blinking or glowing steadily.

Start Button

When system is ready and the START button on the power supply is held in for 1 second, the start sequence is activated that will open the shutter and allow the laser to emit its green laser beam. When the button is first pressed, the two emission indicators on the power supply and the two indicators on the laser head start blinking to warn of impending laser emission. After a 3 second delay, the shutter is opened and the laser emits radiation.

Laser Emission Indicators

When on, the two yellow EMISSION indicators on the power supply (see Figure 2-3) and the two yellow LEDs on the laser head (see Figure 2-5) indicate that power is being supplied to the diode laser, the shutter is open and emission should be present. These indicators blink for 3 seconds before the shutter opens.

Each of the indicators in a pair function identically. They are duplicated for safety; if one indicator fails, the remaining indicator will still be available to warn of present or impending laser radiation.

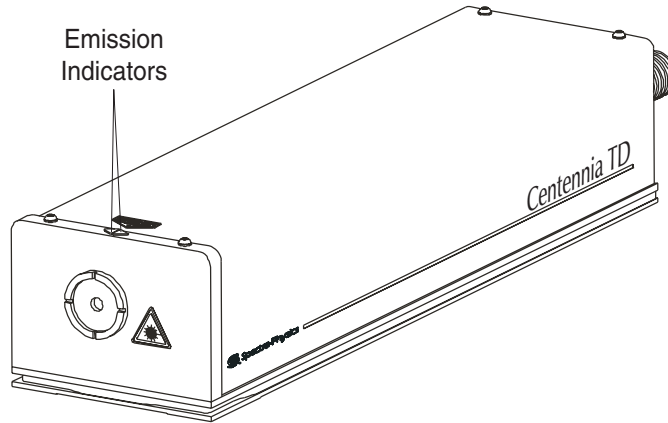

Figure 2-5: Centennia TD Laser Head Emission Indicators

In addition to the indicators provided on the laser head and power supply, the EMISSION relay connector provided on the back of the power supply (see Figure 2-4 and Figure 2-6) can be used to turn on and off an optional user-installed emission indicator. When the shutter is closed (i.e. there is no emission), there is closure between Pins 3 and 1 and an open condition between Pins 3 and 2. The opposite is true when the shutter is open. There is no power supplied by these terminals. This circuit is rated for 30 Vac at 1 A. See Chapter 5 for information about parts that mate to this connector. This relay turns on 3 seconds before actual emission occurs.

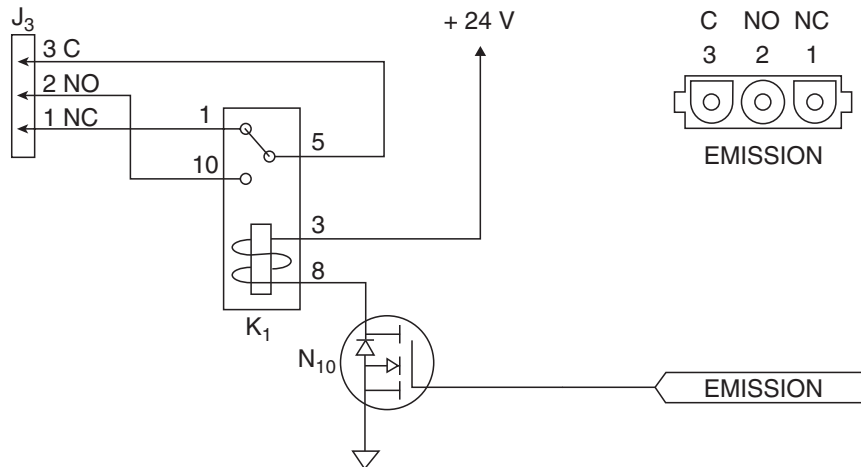

Figure 2-6: Emission Connector Schematic

Power Adjustment Dial

The dial is a rotating adjustment that sets the laser power level in units of Watts in hundredths of a Watt resolution. The power level setting is shown on the LCD Display. The laser operates in a power range from 0.5 W to 5.00 W; the minimum adjustment is 0.05 W. One full turn of the dial causes a change of 1.5 W.

The adjustment provided is relative; the initial position of the dial corresponds to the power level when the laser is turned on (i.e. turning the dial while the system is off will not change the initial power setting when the laser is turned on).

Error Indicator

This yellow LED on the power supply glows when an interlock has been activated, or an internal error has caused the laser to turn off or prevented it from turning on.

Stop Button

The STOP button closes the shutter immediately, thereby blocking laser emission. The laser remains on and laser radiation is present inside of the laser head. If for any reason the shutter does not close, the laser turns off immediately.

Shutter

The laser head internal shutter is electromechanical and is controlled via the power supply front panel. Its interlock fault and fail-safe mode is the closed position. The shutter is opened with the START button, and closed with the STOP button.

External Interlocks

Safety Interlock

The *Centennia* power supply provides a remote safety interlock on the rear panel, the INTERLOCK connector, that can be wired to an external safety switch to stop laser emission (close the shutter) in the event the switch is opened. However, to ensure that the laser can operate even when this interlock is not used, the *Centennia* power supply is shipped with a shorting jumper plug (Figure 2-7) that defeats (closes) the interlock.

Note



The INTERLOCK contacts *must* either be wired to a safety switch or be shorted together using the jumper plug in order for the laser to operate.



Figure 2-7: Interlock Jumper Plug

To use this interlock, remove the jumper plug from the INTERLOCK connector, and use a similar connector to wire to a perimeter safety switch. The jumper plug provided may be used for this purpose if the jumper wire is removed.

The switch can be attached to an access door or to other auxiliary safety equipment. Wire the switch as “normally closed” so that when the door or safety device is opened, the shutter in the laser head is immediately closed, thus protecting personnel from injury.

Note that although the shutter is closed, the diode pump laser remains on and that laser radiation is still present in the laser head. The shutter can be opened and laser operation restored to normal once the interlock fault has been cleared. The laser power level will resume at the set value.

Cover Safety Interlocks

The laser head and power supply covers are not interlocked, as neither unit is allowed to be opened by the user. The warranty on the entire system will be void if the outer cover (or the sealed inner cover) of the laser head is removed, or if the power supply cover is removed. For the benefit of trained service personnel who have been authorized to work on the system, labels under the power supply cover also warn of high voltages and state that power must be off before the internal power supply covers can be removed.

Waste Electrical and Electronic Equipment Recycling Label

To Our Customers in the European Union:

As the volume of electronics goods placed into commerce continues to grow, the European Union is taking measures to regulate the disposal of waste from electrical and electronic equipment. Toward that end, the European Parliament has issued a directive instructing European Union member states to adopt legislation concerning the reduction, recovery, re-use and recycling of waste electrical and electronic equipment (WEEE).

In accordance with this directive, the accompanying product has been marked with the WEEE symbol. See label 3 on page 2-11.

The main purpose of the symbol is to designate that at the end of its useful life, the accompanying product should not be disposed of as normal municipal waste, but should instead be transported to a collection facility that will ensure the proper recovery and recycling of the product's components. The symbol also signifies that this product was placed on the market after 13 August 2005. At this time, regulations for the disposal of waste electrical and electronic equipment vary within the member states of the European Union. Please contact a Newport / Spectra-Physics representative for information concerning the proper disposal of this product.

CDRH Requirements for Operating the Centennia TD

The *Centennia TD* laser head together with the *Centennia* power supply comply with all CDRH safety standards when operated using the controls and adjustments on the front panel of the *Centennia* power supply.

However, if the laser is remotely controlled (through a serial interface), you must provide the following in order to satisfy CDRH regulations:

- **An emission indicator** that indicates laser energy is present or can be accessed. It can be a “power-on” lamp, a computer display that flashes a statement to this effect, or an indicator on the control equipment for this purpose. It need not be marked as an emission indicator so long as its function is obvious. Its presence is required on any control panel that affects laser output.
- **A safety key** must be provided to prevent unauthorized use. The LASER ENABLE keyswitch must be turned to the On position to enable laser operation. If the key is not accessible, software control can be used together with the password feature of your computer. In this case, the LASER ENABLE keyswitch must also be left in the ON position.

Maintenance Necessary to Keep this Laser Product in Compliance with Center for Devices and Radiological Health (CDRH) Regulations

This laser product complies with Title 21 of the *United States Code of Federal Regulations*, Chapter 1, subchapter J, parts 1040.10 and 1040.11, as applicable. To maintain compliance with these regulations, once a year, or whenever the product has been subjected to adverse environmental conditions (e.g., fire, flood, mechanical shock, spilled solvent, etc.), check to see that all features of the product identified on the CDRH Radiation Control Drawing (found later in this chapter) function properly. Also, make sure that all warning labels remain firmly attached.

1. Verify that removing the INTERLOCK jumper plug or opening a user-installed safety switch connected to the *Centennia* power supply (Figure 2-7) prevents laser operation.
2. Verify that the laser can only be turned on when the key switch is in the ON position, and that the key can only be removed when the switch is in the OFF position.
3. Verify that the emission indicator(s) provide a visible signal when the laser emits accessible laser radiation that exceeds the accessible emission limits for Class I*.
4. Verify the time delay between turn-on of the emission indicator(s) and the start of the laser; it must give enough warning to allow action to avoid exposure to laser radiation.
5. Verify that, when the interlock loop is opened, the shutter closes and actually blocks laser radiation emission.

If any of the above items fail to operate as noted and you cannot correct the error, please call your Spectra-Physics service representative for assistance.

*0.39 μ W for CW operation where output is limited to the 400 to 1400 nm range.

CDRH Radiation Control Drawing

Numbers refer to “CE/CDRH Warning Labels” on page 2-11.

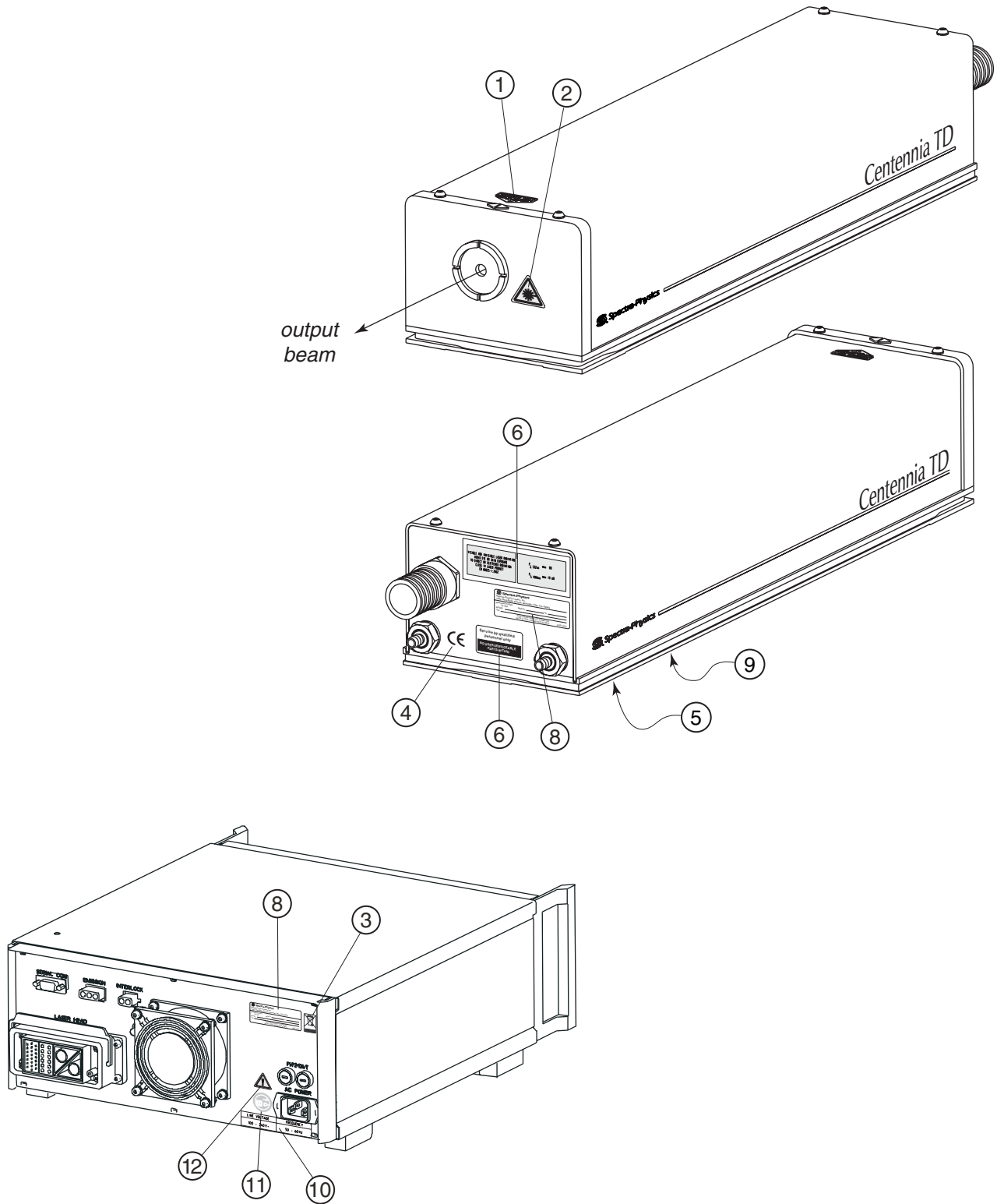

Figure 2-8: CDRH Radiation Control Drawing

CE/CDRH Warning Labels



CDRH Aperture Label
Laser Head (1)



CE Aperture Label (2)



WEEE Label (3)



CE Certification Label (3)

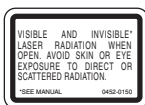

Non-Interlocked Housing Label (4)

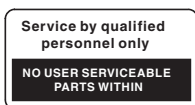

Service Warning Label (5)

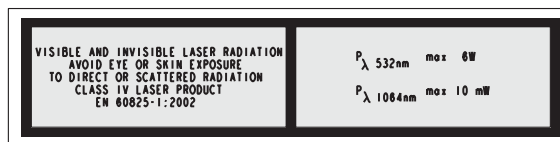

CE Danger, Laser Radiation Label (6)

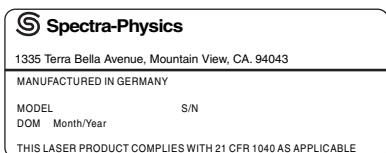

Model / Serial Number Label (7)

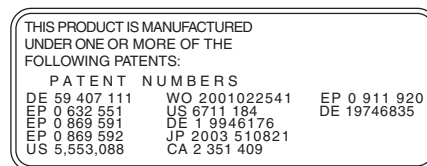

Patent Label (8)

LINE VOLTAGE	FREQUENCY
100 - 240 V~	50 - 60 Hz

Voltage / Frequency Label (9)



Electrical Connection Label (10)



CE Caution Label (11)

Figure 2-9: CE/CDRH Warning Labels

Label Translations

For safety, the following translations are provided for non-English speaking personnel. The number in parenthesis in the first column corresponds to the label number listed on the previous page.

Table 2-1: Label Translations

Label No.	French	German	Spanish	Dutch
Aperture Label (1)	Ouverture Laser - Exposition Dangereuse - Un rayonnement laser visible et/ou invisible est émis par cette ouverture.	Austritt von sichtbarer und unsichtbarer Laserstrahlung! Bestrahlung vermeiden!	Por esta abertura se emite radiación laser visible e invisible; evite la exposición.	Vanuit dit apertuur wordt zichtbare en onzichtbare laserstraling geëmitteerd! Vermijd blootstelling!
CE Danger Laser Radiation (6)	Rayonnement laser visible et/ou invisible. Exposition dangereuse de l'œil ou de la peau au rayonnement direct ou diffus. Laser de classe 4. EN 60825-1:2002 532nm Puissance maximum 6W; 1064nm Puissance maximum 10mW	Sichtbare und/oder unsichtbare Laserstrahlung. Bestrahlung von Auge oder Haut durch direkte oder Streustrahlung vermeiden. Laser Klasse 4. EN 60825-1:2002 532nm maximale Ausgangsstrahlung 6W; 532nm maximale Ausgangsstrahlung 10mW	Radiación láser visible y/o invisible. Evitar la exposición directa ó dispersa sobre la piel o los ojos. Producto Láser Clase 4. EN 60825-1:2002 532nm Potencia máxima 6W; 1064 Potencia máxima 10mW	Zichtbare en/of onzichtbare* laser straling. Vermijd blootstelling aan ogen of huid door directe of gereflecteerde straling. Klasse 4 laser produkt. EN 60825-1:2002 532nm maximaal uittredend vermogen 6 W; 1064nm maximaal uittredend vermogen 10mW
Patent Labels (8)	Ce produit est fabriqué sous l'un ou plusieurs des brevets suivants:	Dieses Produkt wurde unter Verwendung einer oder mehrerer der folgenden hergestellt:	Este producto esta fabricado con una o más de las siguientes patentes:	Dit product is gefabriceerd met een of meer van de volgende patenteren:

CE Declaration of Conformity

We,

Spectra-Physics
1335 Terra Bella Avenue
Mountain View, CA. 94043
United States of America

declare under our sole responsibility that the following products:

Centennia TD Laser System

manufactured after July 1, 2005

meet the intent of the EMC Directive 89/336/EEC (2004/C 98/05) for electromagnetic compatibility and 73/23/EEC (1973) for low voltage directives. Compliance was demonstrated to the following Specifications as listed in the official *Journal of the European Communities*:

EMC Directive 89/336/EEC (2004/C 98/05):

EN 61326-1: 1997 + A1 A2 A3: Electrical equipment for measurement control and laboratory use — EMC requirements.

EN 61000-3-2: (EMC) — Part 3: Limits - Section 2: Limits for harmonic current emissions.

EN 61000-3-3: (EMC) — Part 3: Limits - Section 3: Limitation of voltage fluctuations and flicker in low voltage supply systems for equipment with rated current ≤ 16 A.

EN 61000-4-2: (EMC) — Part 4: Testing and measurement techniques—
Section 2: Electrostatic discharge immunity test.

EN 61000-4-3: (EMC) — Part 4: Testing and measurement techniques—
Section 3: Radiated radio frequency, electromagnetic field immunity test.

EN 61000-4-4: (EMC) — Part 4: Testing and measurement techniques—
Section 4: Electrical fast transient/burst immunity test.

EN 61000-4-5: (EMC) — Part 4: Testing and measurement techniques—
Section 5: Surge immunity test.

EN 61000-4-6: (EMC) — Part 4: Testing and measurement techniques—
Section 6: Immunity to conducted disturbances induced by radio frequency fields.

EN 61000-4-8: (EMC) — Part 4: Testing and measurement techniques—
Section 8: Power frequency magnetic field immunity test.

EN 61000-4-11: (EMC) — Part 4: Testing and measurement techniques—
Section 11: Voltage dips, short interruptions and voltage variation immunity test.

Low Voltage Directive 73/23/EEC (1973):

EN60825-1: (2002) + A1 + A2 — Part 1: Equipment classification, requirements, and user's guide, safety of laser products.

EN 61010-1: (2001): Safety requirements for electrical equipment for measurement, control and laboratory use—Part 1, General requirements.

I, the undersigned, hereby declare that the equipment specified above conforms to the above Directives and Standards.

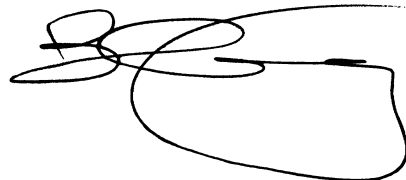

Bruce Craig
Vice President
Spectra-Physics / Newport
July 1, 2005

Sources for Additional Information

Laser Safety Standards

Safe Use of Lasers (Z136.1)

American National Standards Institute (ANSI)

11 West 42nd Street

New York, NY 10036

Tel: (212) 642-4900

Occupational Safety and Health Administration (Publication 8.1-7)

U. S. Department of Labor

200 Constitution Avenue N. W., Room N3647

Washington, DC 20210

Tel: (202) 693-1999

Internet: www.osha.gov

A Guide for Control of Laser Hazards, 4th Edition, Publication #0165

American Conference of Governmental and

Industrial Hygienists (ACGIH)

1330 Kemper Meadow Drive

Cincinnati, OH 45240

Tel: (513) 742-2020

Internet: www.acgih.org/home.htm

Laser Institute of America

13501 Ingenuity Drive, Suite 128

Orlando, FL 32826

Tel: (800) 345-2737

Internet: www.laserinstitute.org

Compliance Engineering

Canon Communications LLC

11444 W. Olympic Blvd

Los Angeles, CA 90064

Tel: (310) 445-4200

International Electrotechnical Commission

Journal of the European Communities

EN60825-1 Safety of Laser Products — Part 1: Equipment classification, requirements and user's guide

Tel: +41 22-919-0211 Fax: +41 22-919-0300

Internet: www.iec.ch

Cenelec

35, Rue de Stassartstraat

B-1050 Brussels, Belgium

Tel: +32 2 519 68 71

Internet: www.cenelec.org

Document Center, Inc.

111 Industrial Road, Suite 9

Belmont, CA 94002

Tel: (650) 591-7600

Internet: www.document-center.com

Equipment and Training

Laser Safety Guide

Laser Institute of America
13501 Ingenuity Drive, Suite 128
Orlando, FL 32826
Tel: (407) 380-1553, or toll-free
(800) 34LASER
Internet: www.laserinstitute.org

Laser Focus World Buyer's Guide

Laser Focus World
Pennwell Publishing
98 Spit Rock Road
Nashua, NH 03062
Tel: (603) 891-0123
Internet: lfw.pennnet.com/home.cfm

Photonics Spectra Buyer's Guide

Photonics Spectra
Laurin Publications
Berkshire Common
PO Box 4949
Pittsfield, MA 01202-4949
Tel: (413) 499-0514
Internet: www.photonics.com

A Brief Review of Laser Theory

*Emission and Absorption of Light**

Laser is an acronym derived from Light Amplification by Stimulated Emission of Radiation. Unlike thermal radiators, which emit light in all directions, the laser is an amplifier of light, and because its output comprises photons that are identical in phase and direction, its output beam is singularly directional, monochromatic, and coherent.

Radiant emission and absorption take place within the atomic or molecular structure of materials. Each electron occupies a distinct orbital that represents the probability of finding the electron at a given position relative to the nucleus. The energy of an electron is determined by the orbital that it occupies, and the over-all energy of an atom—its energy level—depends on the distribution of its electrons. The level with the lowest possible energy is called the ground state, and higher energy levels are called excited states. If an atom is in its ground state, it will stay there until it is excited by external forces.

Movement from one energy level to another—a transition—happens when the atom either absorbs or emits energy. Upward transitions can be caused by collision with a free electron or an excited atom, and transitions in both directions can occur as a result of interaction with a photon of light. Consider a transition from a lower level whose energy content is E_1 to a higher one with energy E_2 . It will only occur if the energy of the incident photon matches the energy difference between levels, i.e.,

$$h\nu = E_2 - E_1 \quad [1]$$

where h is Planck's constant, and ν is the frequency of the photon.

Likewise, when an atom excited to E_2 decays to E_1 , it loses energy equal to $E_2 - E_1$. The atom may decay spontaneously, emitting a photon with energy $h\nu$ and frequency

$$\nu = \frac{E_2 - E_1}{h} \quad [2]$$

* "Light" will be used to describe the portion of the electromagnetic spectrum from far infrared to ultraviolet.

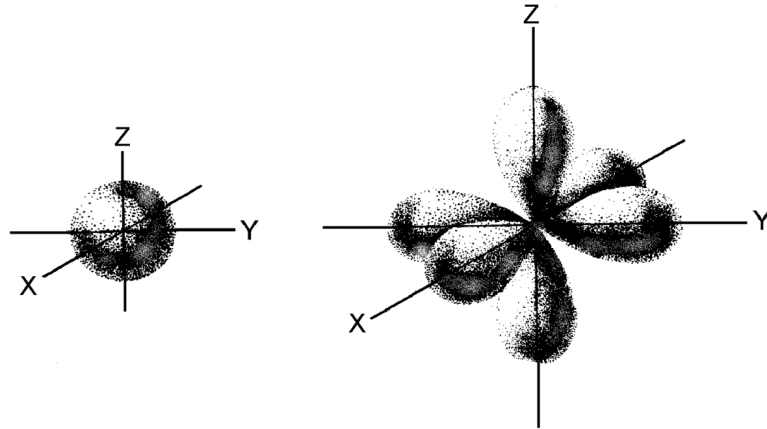

Figure 3-1: Electrons occupy distinct orbitals that are defined as the probability of finding an electron at a given position. The shape of the orbital is determined by the radial and angular dependence of this probability.

An atom excited to E_2 can also be stimulated to decay to E_1 by interacting with a photon of frequency ν , emitting energy in the form of a pair of photons that are identical to the incident one in phase, frequency, and direction. This is known as stimulated emission. By contrast, spontaneous emission produces photons that have no directional or phase relationship with one another.

A laser is designed to take advantage of absorption, and both spontaneous and stimulated emission phenomena, using them to create conditions favorable to light amplification.

Population Inversion

The net absorption at a given frequency is the difference between the rates of emission and absorption at that frequency. It can be shown that the rate of excitation from E_1 to E_2 is proportional to the number of atoms in the lower level N_1 . Similarly, the rate of stimulated emission is proportional to the population of the upper level N_2 . Moreover, the probability of a transition depends on the flux of the incident wave and a characteristic of the transition called its “cross section.” The absorption coefficient depends only on the difference between the populations involved, N_1 and N_2 , and the flux of the incident wave.

When a material is at thermal equilibrium, there is a distribution of its atoms over the array of available energy levels with most atoms in the ground state. Since the rate of absorption of all frequencies exceeds that of emission, the absorption coefficient at any frequency is positive.

If enough light of frequency ν is supplied, the populations can be shifted until $N_1 = N_2$. Under these conditions the rates of absorption and stimulated emission are equal, and the absorption coefficient at frequency ν is zero. If the transition scheme is limited to two energy levels, N_2 can never exceed N_1 because every upward transition is matched by one in the opposite direction.

However, if three or more energy levels are employed, and if their relationship satisfies certain requirements described below, additional excitation can create a population inversion where $N_2 > N_1$.

A model four-level laser transition scheme is depicted in Figure 3-2. A photon of frequency ν_1 excites—or “pumps”—an atom from E_1 to E_4 . If the E_4 to E_3 transition probability is greater than that of E_4 to E_1 , and if the lifetime of an atom at E_4 is short, the atom will decay almost immediately to E_3 . If E_3 is metastable, i.e., atoms that occupy it have a relatively long lifetime, the population will grow rapidly as excited atoms cascade from above.

The E_3 atom will eventually decay to E_2 , emitting a photon of frequency ν_2 . Finally, if E_2 is unstable, its atoms will rapidly return to the ground state, E_1 , keeping the population of E_2 small and reducing the rate of absorption of ν_2 . In this way the population of E_3 is kept large and that of E_2 remains low, thus establishing a population inversion between E_3 and E_2 . Under these conditions, the absorption coefficient at ν_2 becomes negative. Light is amplified as it passes through the material, which is now called an “active medium.” The greater the population inversion, the greater the gain.

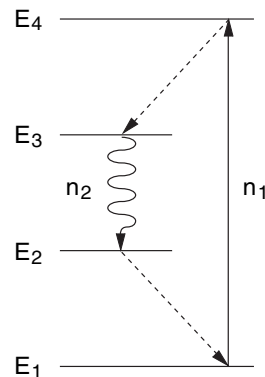

Figure 3-2: A Typical Four-level Transition Scheme

Resonant Optical Cavity

To sustain lasing action, most laser gain materials must be placed in a resonant optical cavity. This most often consists of two mirrors that reflect laser emission back through the gain material, i.e., a photon emitted parallel to the cavity axis is trapped in the cavity. Then stimulated emission produces two photons of equal energy, phase, and direction for each reflected photon. The two photons become four, four become eight, and the numbers continue to increase geometrically until an equilibrium between excitation and emission is reached.

Both cavity mirrors are coated to capture the wavelength, or wavelengths, of interest while allowing all others to pass out of the cavity. One of the mirrors, the output coupler, also transmits a fraction of the energy stored within the cavity, and this radiation forms the output beam of the laser.

The laser light within the resonant cavity oscillates within a narrow range of frequencies (and corresponding wavelengths) supported by the transition frequency of the laser material.

Nd³⁺ as a Laser Medium

The source of excitation energy for a crystalline laser gain medium is usually optical, typically another laser. The *Centennia TD* uses the near infrared output from a diode laser to pump Nd^{3+} ions that have been doped into a yttrium vanadate crystalline matrix ($Nd:YVO_4$, referred to simply as “vanadate”).

The properties of neodymium-doped matrices are the most widely studied and best understood of all solid-state laser media. The four-level Nd^{3+} ion scheme is shown in Figure 3-3. The active medium is triply ionized neodymium, which has principle absorption bands in the red and near infrared.

The electrons in the neodymium ions are very efficient at absorbing the diode laser light, which excites them to the “pump bands” shown in the figure. The excited electrons quickly drop to the $^4F_{3/2}$ level, the upper level of the lasing transition, where they remain for a relatively long time.

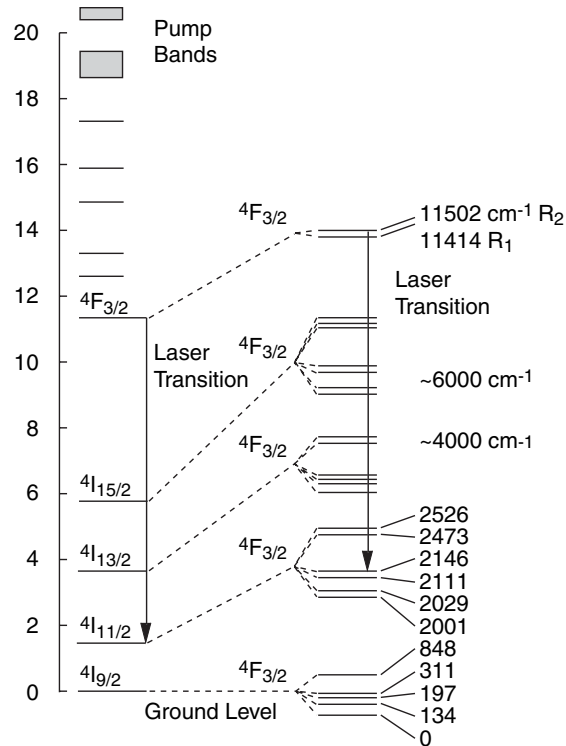

Figure 3-3: Energy Level Scheme for the Nd^{3+} Ion

The most probable lasing transition is to the $^4I_{1/2}$ state, where a photon at 1064 nm is emitted. Because electrons in that state quickly relax to the ground state, the population of this state remains low. Hence, it is easy to build a population inversion, in which the number of electrons in the higher energy level exceeds the number in the lower level. At room temperature the emission cross section of the transition between these laser levels is high, so its lasing threshold — the number of photons required to start the stimulated emission of laser light — is low.

Diode-Pumped Laser Design

Diode lasers combine very high brightness, high efficiency, monochromaticity and compact size in a near-ideal source for pumping solid-state lasers. Figure 3-4 shows the monochromaticity of the emission of a diode laser compared to a krypton arc lamp and compares that with the absorption spectra of the Nd^{3+} ion. The near-perfect overlap of the diode laser output with the Nd^{3+} absorption band ensures that the pump light is efficiently coupled into the laser medium. It also reduces thermal loading since any pump light *not* coupled into the medium is ultimately removed as heat.

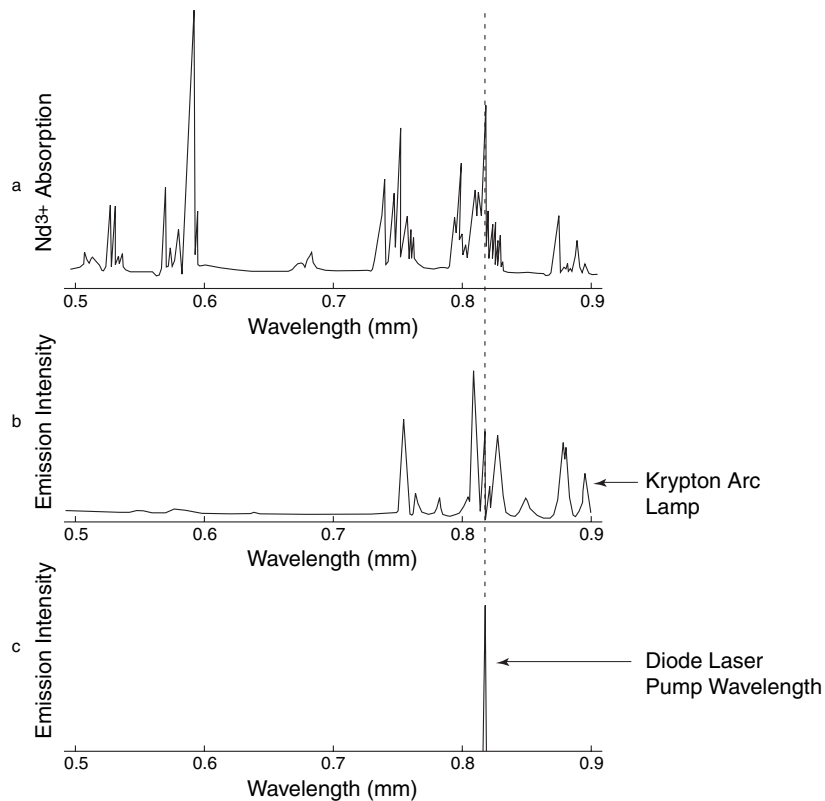

Figure 3-4: Nd^{3+} absorption spectra (a) compared to the emission of a Krypton Arc Lamp (b) and a Diode Laser Pump (c).

Spectra-Physics uses as a pump laser a high power diode laser with an emission at 808 nm. These devices are simple and reliable pump laser sources.

The emission wavelength of a diode laser is dependant on its internal temperature, and so on the density of the drive current in the device. Therefore both the diode laser temperature and drive current must be stabilized to maintain the optimum pump wavelength to produce efficient absorption.

Another key element in optimizing the efficiency of a solid-state laser is maximizing the overlap in the laser crystal (the vanadate) of the region that is excited by the pump source with that occupied by the fundamental beam. The absorption depth in the laser crystal of the pump wavelength is an important consideration here, particularly for designs using thin-disk technology.

Thin-Disk Laser Technology

Conventional diode-pumped solid-state lasers typically have their gain material doped into a crystal with either a cylindrical or a rectangular geometry. The major drawback to achieving both high peak output power and good beam quality from these types of lasers is the formation of a temperature gradient perpendicular to the beam direction through the crystal.

Above a threshold of pump power, this temperature gradient leads to a refractive index gradient (a “thermal lens”) that focuses the laser beam itself. The focusing of the beam in turn intensifies the thermal lens effect even further. This ultimately limits the output power and beam quality, and in extreme cases may even cause damage to the laser crystal.

The thin-disk laser was developed to overcome these difficulties. In this innovative design, the laser crystal is formed as a disk only a fraction of a millimeter in thickness. This disk receives a coating on one face that is highly reflective at both the laser wavelength and the pump laser wavelength. The coated face of the thin disk is then bonded to a heatsink. Because the disk is so thin, excellent cooling efficiency and uniformity can be achieved at high levels of pump energy density, thereby avoiding thermal lensing.

In order to achieve a sufficient degree of absorption of the pump light in the thin disk, the diode laser pump beam light is reflected multiple times through the disk. The output surface of the disk has an anti-reflection coating. A mirror that is partially transmitting at the laser wavelength reflects the output back into the thin-disk gain medium in order for stimulated emission to extract all of the available gain.

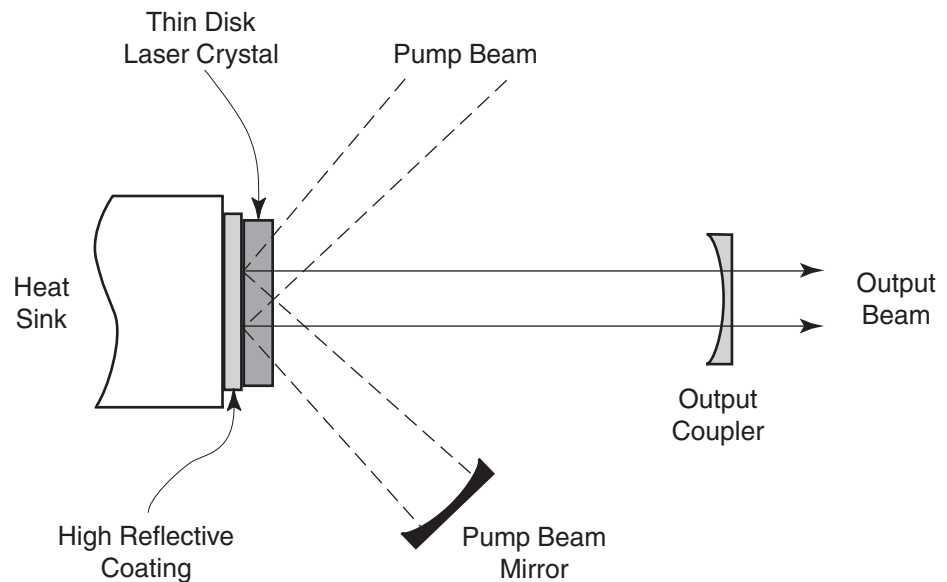

Figure 3-5: Thin-Disk Laser Cavity

Thin-disk laser technology enables high-power, diode-pumped solid-state laser designs of compact size that are exceptionally robust and stable, as well as cost-effective.

Frequency Doubling

In the *Centennia TD*, the high output power from the diode laser is used to pump the vanadate lasing medium. The resulting 1064 nm output is converted to visible light through frequency doubling (also called “second harmonic generation”) in a nonlinear crystal. The *Centennia TD* uses a critically phase-matched, temperature-tuned lithium triborate (LBO) nonlinear crystal as its doubling medium.

Phase matching is a requirement in almost all applications of nonlinear optics in order to achieve an efficient conversion of the fundamental incident light to an output beam at a new wavelength. In order to produce any significant output at the new wavelength, the phases of the fundamental light wave and the converted light wave must stay in phase over a sufficient length in the nonlinear material to allow the conversion to take place.

In a nonlinear crystalline material, however, the indexes of refraction at the two wavelengths will be significantly different, causing the two waves to become rapidly out of phase unless special techniques are employed. One such technique takes advantage of the birefringent nature of nonlinear crystals. The indexes of refraction of the two light waves can be made to match exactly if the direction of propagation and the polarization orientation of the beams are carefully controlled. This technique is referred to as “critical phase matching.”

Although LBO has a lower nonlinear coefficient than other materials, it offers other critical advantages. It produces no spatial “walk-off” of the fundamental and second harmonic beams, which preserves the high spatial mode quality and favors a long interaction length for higher gain, and the crystal can be easily optimized for maximum conversion efficiency by simply changing its temperature (with no realignment of the laser cavity).

In frequency doubling, the second harmonic power ($P_{2\omega}$) is given by:

$$P_{2\omega} \propto \frac{d_{\text{eff}}^2 P_{\omega}^2 l^2 [\phi]}{A} \quad [5]$$

where d_{eff} is the effective nonlinear coefficient, P_{ω} is the fundamental input power, l is the effective crystal length, $[\phi]$ is a phase-matching factor, and A is the cross-sectional area of the beam in the crystal.

Since the second harmonic output is dependent upon the square of the fundamental peak power, very high conversion efficiencies can be achieved by placing the doubling crystal within the laser resonator itself to take advantage of the high circulating intensity (this is called “intracavity frequency doubling”). This is the technique used in the *Centennia TD*.

The Centennia TD System

The *Centennia TD* system comprises the *Centennia TD* laser head and the *Centennia* power supply. An umbilical cable permanently attached to the laser head provides control and electrical power from the power supply. The *Centennia TD* laser head is water-cooled. An optional recirculating chiller is available for supplying the specified water flow.

The following sections describe the laser head and power supply. The chiller is described in its user's manual.

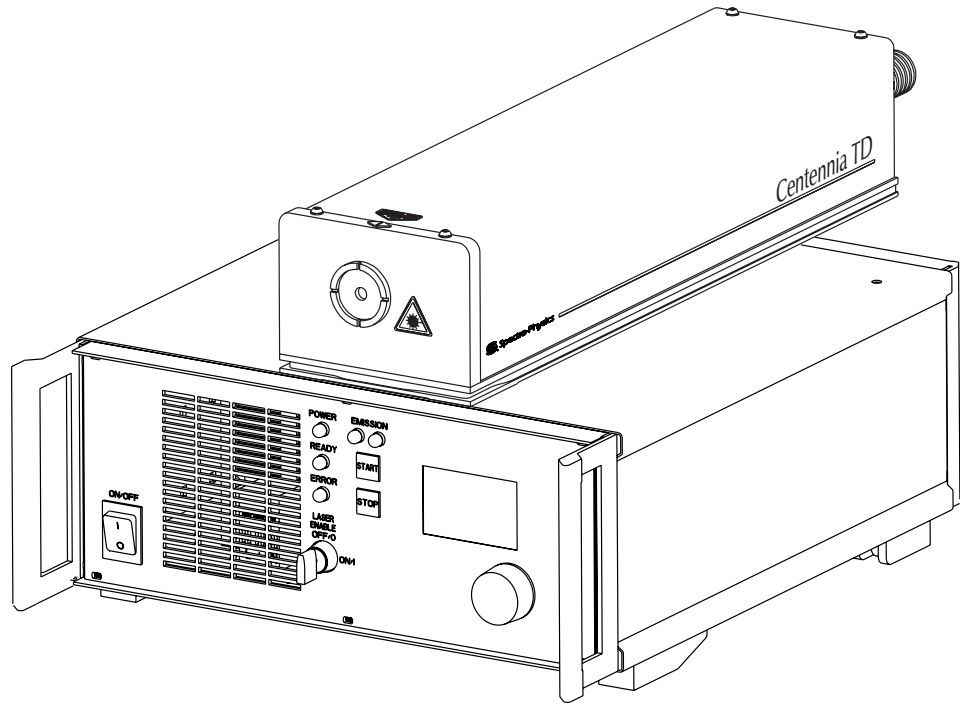

Figure 3-1: *Centennia TD* System (chiller not shown)

The laser head is designed for maximum reliability with minimum complexity. The *Centennia TD* vanadate thin-disk crystal is energized by a diode pump laser inside the laser head. The vanadate infrared output is then intracavity frequency doubled in a lithium triborate (LBO) crystal to produce the green laser beam. The operation is inherently so stable and the output so quiet that no adjustments are needed in normal operation.

The Centennia TD Laser Head

Figure 3-2 illustrates the optical design of the *Centennia TD* laser head. A lens (not shown in the diagram) focuses the high-power diode laser pump light into the thin crystalline disk of vanadate, which generates the 1064 nm infrared intracavity light. The back of the disk has a coating that is highly reflective at the 1064 nm wavelength. The disk is bonded to a heat sink for superior thermal stability.

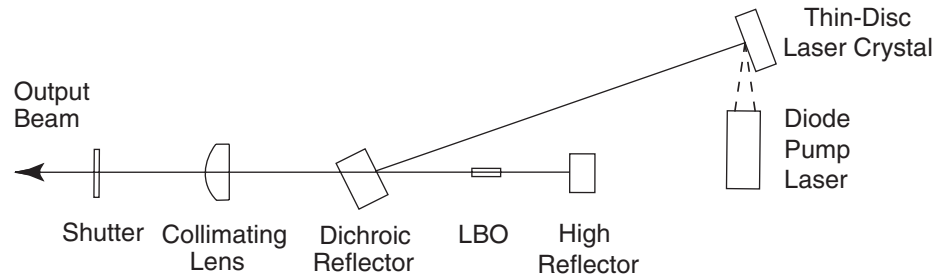

Figure 3-2: Optical Layout of the *Centennia TD* Laser Head

Frequency Doubling

The fundamental 1064 nm beam is directed into the frequency-doubling limb of the resonator by a dichroic reflector. The 1064 nm beam passes through the LBO crystal where the 532 nm harmonic beam is generated. The LBO is oriented at the critical phase-matching angle required for frequency doubling, and temperature-tuned for the maximum production of green light. Heating the LBO also counters the absorption of humidity, which can cloud and damage the crystal. A compact temperature-regulated mount is used to maintain the crystal at the appropriate temperature, about 40°C, to optimize the conversion to 532 nm power.

Both the fundamental beam and the green beam are reflected back by a high reflector for a second pass through the LBO crystal. The frequency-doubled green beam then passes through the dichroic output coupler and is directed out of the laser, while virtually all of the fundamental beam is reflected by the dichroic output coupler and trapped within the laser head.

Beam Delivery

A lens collects and collimates the output beam, and a 90° polarization rotator aligns the polarization axis to vertical orientation (horizontal polarization is available as an option). The beam is expanded to its final output diameter and divergence by a telescopic lens combination. The shutter blocks the beam until commanded to open by pressing and holding in the START button on the power supply.

A beam splitter and photodiode sample the output and provide feedback to the pump laser driver to provide a constant output. The light pick-off is an integral part of the system. The minimum power output from the laser is 0.50 W; the maximum power level is greater than 5 W.

Cooling

Waste heat in the laser head is generated by thermo-electric coolers that maintain the LBO crystal and the diode pump laser at their proper operating temperature. Waste heat is also produced by the laser light that is not completely absorbed in the pumping and frequency-doubling processes. The combined heat from these sources totals less than 300 W, and it is removed from the laser head by the flow of cooling water provided by a recirculating chiller. Hoses (metric dimensions, no polarity) are permanently attached to the laser head for the recirculating water flow.

The Centennia Power Supply

The air-cooled *Centennia* power supply provides current for the diode pump laser in the laser head, and it is the control unit for the system as well. The power supply is auto-ranging. For electrical power it requires a standard 50 or 60 Hz electrical supply from 100 to 240 Vac.

An optional kit is available to mount the power supply in a standard 19" rack.

System Control

Starting and stopping the laser is straightforward using the controls on the power supply, as described in Chapter 6, "Operation." Control of the output power is by means of the dial control and LCD display on the power supply front panel.

The system can also be controlled by serial commands via the standard RS-232 interface on the back of the power supply.

Note



For information about system integration of the *Centennia TD* (e.g. mounting the power supply in a rack, controlling the laser using serial commands, etc.), contact your Spectra-Physics representative.

Specifications

Table 3-1: Centennia TD Laser Output Characteristics¹

Power	
maximum	> 5 W
minimum	0.5 W
Wavelength	532 nm
Spatial Mode²	TEM ₀₀
Beam diameter at 1/e² points³	2.3 mm ± 10%
Beam divergence, full angle	< 0.5 mrad
Polarization⁴	> 100:1 vertical
Power Stability⁵	± 3%
Beam Pointing Stability⁶	< 5 µrad/°C
Noise	< 0.4% rms
Boresight Tolerance	
nearfield	± 0.25 mm
farfield	< 10 mrad

¹Specifications are subject to change without notice.

² $M^2 < 1.2$; beam ellipticity < 20%.

³Measured at the output face of the laser.

⁴Horizontal polarization may be ordered as a factory-installed option.

⁵Measured over a 1-hour period after a 20-minute warmup.

⁶Measured as far-field x and y positions, after a 20-minute warmup.

Table 3-2: Utilities

AC power input	100 to 240 Vac ± 10%, 50/60 Hz, single phase
Power consumption Centennia Power Supply	500 W typical, 1100 W maximum
Heat dissipation into room, typical¹	460 W

¹Note that the chiller will also produce heat. Consult your chiller manual for details.

Table 3-3: Fuse Ratings for F1 and F2

Power Supply	Supply Voltage	Rating	Type
Centennia TD	100–240 Vac, 50/60 Hz	10 A	T 10 A, 250 V

Table 3-4: Dimensions and Weight

Laser Head	
size (w x h x d)	5.31 x 4.02 x 19.49 in. (13.5 x 10.2 x 49.5 cm)
weight	44 lb (20 kg)
umbilical length ¹	13 ft (4 m)
minimum static bend radius	6 in. (15 cm)
water hoses - length ¹	13 ft (4 m)
ID	(6 mm)
OD	(8 mm)
Centennia Power Supply	
size (w x h x d)	13.7 x 5.26 x 16.43 in. (34.9 x 13.35 x 41.74 cm)
weight	17.6 lb (8 kg)

¹*Umbilical and hose lengths are approximate.*

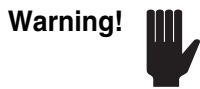

It is critical that the chiller meet the requirements for cooling the laser head. Failure to do so will result in poor performance, and possibly cause damage to the laser. Such damage is not covered by the warranty.

The following requirements must be met by the chiller in order to properly cool the *Centennia TD* laser head. Refer to the manual provided with the chiller for its dimensions, specifications and utility requirements.

- The chiller must meet these requirements over the entire environmental operating temperature range of the system, 18°C to 35°C.
- The chiller should use distilled water.
- The chiller output flow must use a partial flow liquid filter of 100 µm or smaller filter size.

Table 3-5: Chiller Requirements

water flow rate	
recommended	3.0 to 3.5 liters/minute (0.8 to 0.9 gallons/minute)
minimum	2.0 liters/minute (0.5 gallons/minute)
water temperature	20 ±0.5°C (68 ±0.9°F)
maximum pressure at the laser head inlet	5 bar (73 psi)

Outline Drawings

All measurements shown in $\frac{\text{inches}}{\text{millimeters}}$

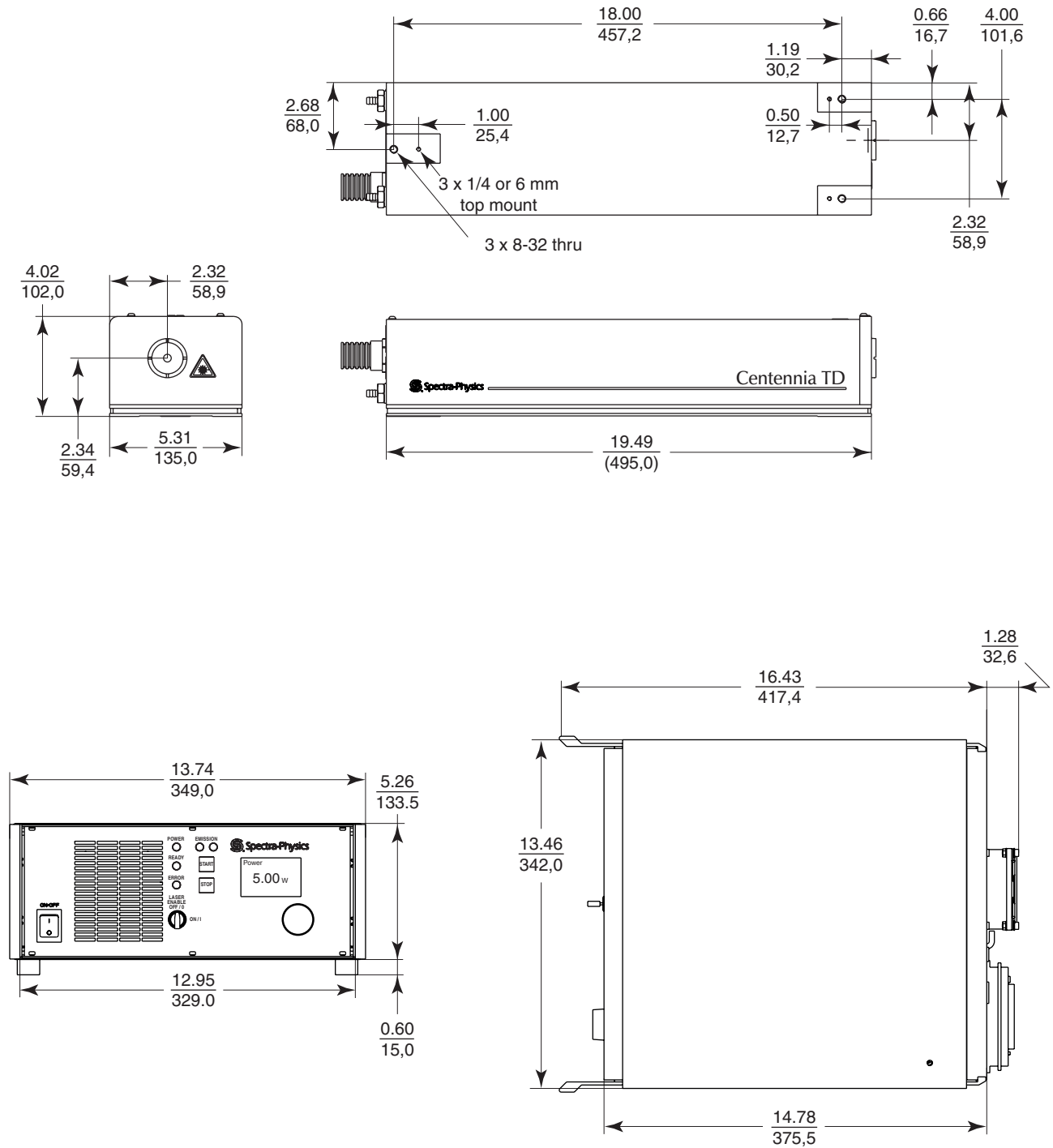

Figure 3-3: Outline Drawings for Laser Head and Power Supply

This section defines the user controls, indicators and connections of the *Centennia TD* laser head and the power supply. Information on the chiller can be found in the user's manual for that product. Operating the laser system is described in Chapter 6.

The Centennia TD Laser Head

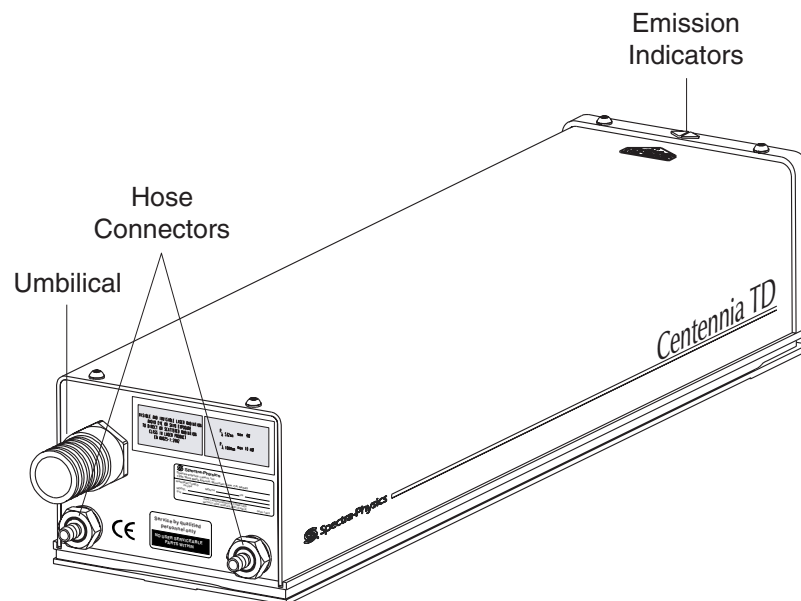

Figure 4-1: *Centennia TD* Laser Head

Controls

There are no adjustments on or inside the *Centennia TD* laser head.

Indicators

Laser Emission indicators (yellow)—warn of present or imminent laser radiation. These CDRH indicators are located on top of the laser near the output end. They blink during the 3 second delay between when the START button is pressed and the actual emission, at which time the indicators glow steadily. The two indicators are redundant for safety.

Legs

Legs (3)—(optional, shipped with the *Tsunami*[®] laser when ordered) provide a means to set the level of the output laser beam to a height appropriate for pumping a Spectra-Physics *Tsunami* Ti:sapphire oscillator. The legs are sturdy, precision machined posts that screw into the #8-32 holes on the 3 mounting pads located on the bottom of the laser head. Table clamps are provided. There are no height adjustments.

Connections

Umbilical connector—provides control signals and power to the laser head. Disconnect the umbilical only at the power supply. *This umbilical is permanently attached to the laser head: do not try to remove it.*

Water hoses—provide connection for the recirculating flow of cooling water from the chiller to the laser head. The hoses have metric dimensions—see Table 3-4 on page 3-12. You will need to provide connectors to mate these hoses to the chiller. *These hoses are permanently attached to the laser head: do not try to remove them.*

Centennia Power Supply

Power Supply Front Panel

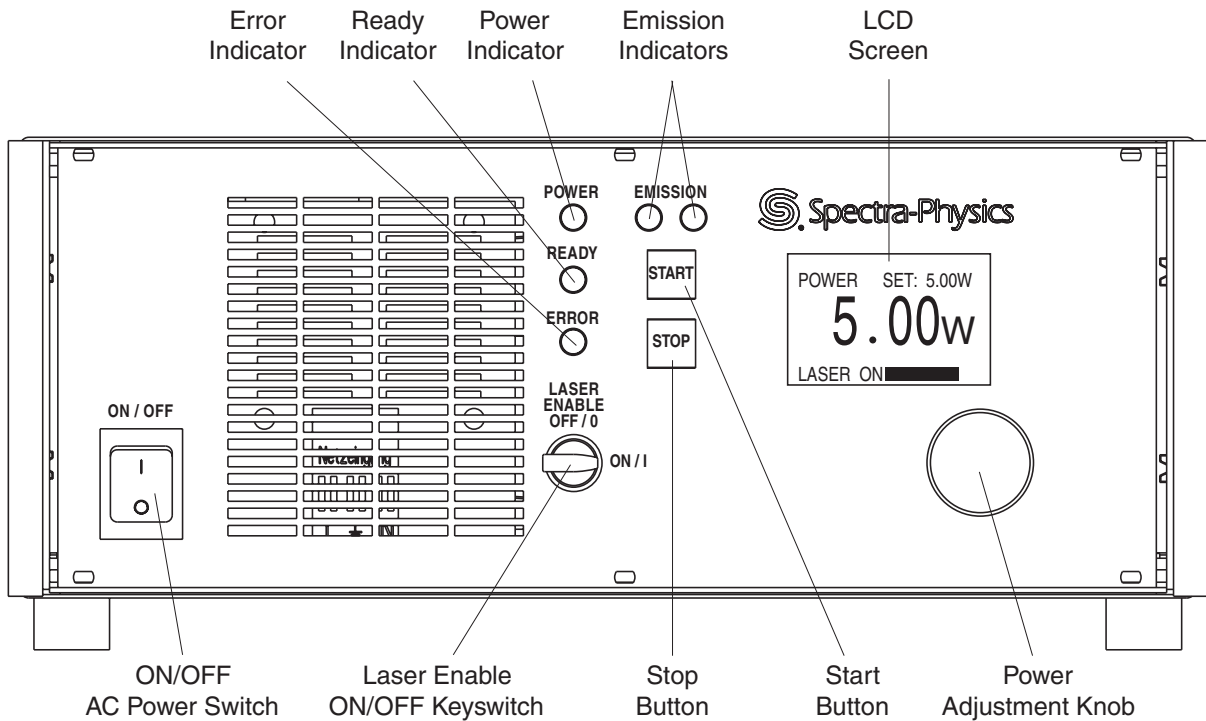

Figure 4-2: Centennia Power Supply Front Panel

LCD screen— displays the power setting and the actual power output of the laser. It also displays the progress of the warm-up cycle at startup.

The requested power output of the laser is displayed in small characters in Watts to a hundredth of a Watt resolution (e.g. 5.00 W). The actual power output of the laser is displayed in large characters on the LCD.

Warm-up begins when the LASER ENABLE keyswitch is set to ON. The warm-up takes a few minutes to complete; progress is indicated by the advance of the bar from left to right on the bottom of the screen.

If the system encounters a fault, a status code corresponding to the fault condition is displayed at the bottom of the screen in place of the “Laser On” message that is displayed during normal operation.

ON/OFF AC power switch— enables electrical power to the power supply.

POWER indicator (green)— indicates that electrical power is applied to the power supply circuitry.

LASER ENABLE keyswitch— starts or terminates the production of laser radiation inside the laser head. The keyswitch provides interlock safety to prevent unauthorized personnel from using the laser when the key is turned to the OFF position and is then removed. Turning the key to the ON position provides current to the diode pump laser and to the crystal oven in the laser head if the AC power switch is also turned on.

If the LASER ENABLE keyswitch is already in the ON position when the AC power switch is turned on, the laser will not start. If this occurs, cycle the keyswitch off and back on.

READY indicator (green)— when blinking, indicates that current is supplied to the laser head and that the diode pump laser and the crystal oven are warming to temperature. This indicator glows steadily when the laser is ready to operate. Laser emission is present inside of the laser head when this indicator is either blinking or glowing steadily.

When the start sequence is initiated, a high level of laser radiation is temporarily present inside the laser, regardless of the set power level. This transient condition is produced by current applied to the diode pump laser as part of the process that warms the laser to its proper operating temperature. Laser emission is blocked by the shutter. When the shutter opens, laser emission should be at the selected power level.

START button— once the READY indicator glows steadily, holding this button in for at least 1 second will initiate the sequence that opens the shutter. After a CDRH delay of 3 seconds, the shutter will open and the laser beam will be emitted. The laser comes on at the power setting shown on the LCD screen.

Laser EMISSION indicators (yellow)— when blinking, these two LEDs on the laser head indicate that current is supplied to the diode pump laser in the laser head, the laser is producing laser radiation, and the shutter will be opened in 3 seconds or less. These indicators glow steadily when the shutter is open and laser emission is present. The two indicators are redundant for safety.

Power Adjustment Dial— a rotating adjustment that sets the laser power level in units of Watts in hundredths of a Watt resolution. The power level setting is shown on the LCD Display. The operating range of power is from 0.5 W to 5.00 W; the minimum adjustment is 0.05 W. One full turn of the dial causes a change of 1.5 W.

The adjustment provided is relative; the initial position of the dial corresponds to the power level when the laser is turned on (i.e. turning the dial when the laser is off will not change the power setting when the laser is turned on).

ERROR indicator (yellow)—illuminates when there is an active interlock or a system failure, and indicates that the diode laser power has been turned off. To clear the error status, turn off the keyswitch, correct the underlying problem, and cycle the AC power off and back on.

STOP button— pressing this button closes the laser head shutter immediately. Note that laser emission is still present inside of the laser head.

Power Supply Rear Panel

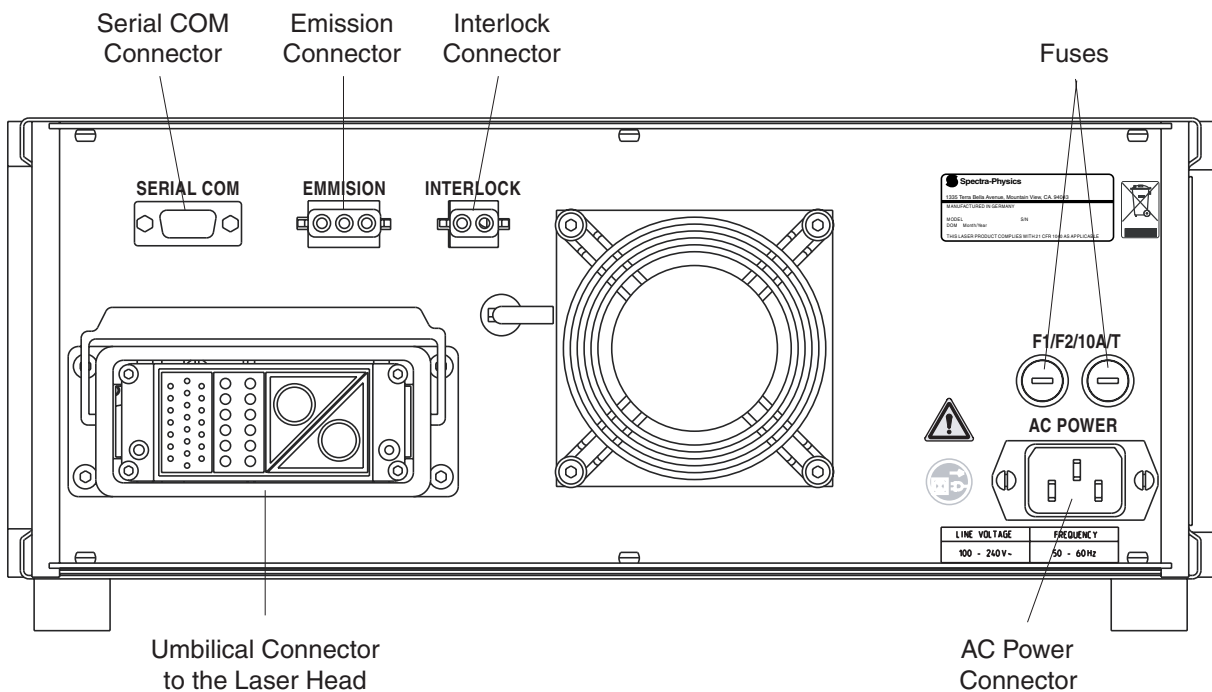

Figure 4-3: Centennia Power Supply Rear Panel

SERIAL COM connector (9-pin, D-sub)—is reserved at present for use by Spectra-Physics. For information about using this connector for remote computer control of the *Centennia TD* system using serial commands, contact your Spectra-Physics representative.

EMISSION relay connector (3-pin AMP)—provides a relay that can be used to turn on and off a user-installed indicator that warns of laser emission. See “EMISSION Connector” on page 4-5 for more information.

INTERLOCK connector (2-pin AMP)—provides attachment for a user-supplied safety switch. These contacts must be shorted together before the laser will operate. A defeating jumper plug (Figure 4-4) is installed at the factory to permit operation without a safety switch. See “Safety INTERLOCK Connector” on page 4-6 for more information.



Figure 4-4: INTERLOCK Jumper Plug

Umbilical connector—provides attachment for the umbilical cable that provides monitoring, control and diode laser drive current to the *Centennia TD* laser head.

AC POWER connector—provides attachment for an IEC power cable to provide AC power to the *Centennia* power supply.

Connector Interface Descriptions

Serial COM Connector

Note



At present, this serial connector is reserved for factory use. For information about system integration of the *Centennia TD* (e.g. controlling the laser using serial commands), contact your Spectra-Physics representative.

EMISSION Connector

This connector is used to turn on and off an optional user-installed emission indicator. When there is no laser emission (i.e. the shutter is closed), there is closure between the NC and C terminals and an open between the NO and C terminals. The opposite is true when there is emission or emission is imminent. Refer to the circuit diagram in Figure 4-5 below.

There is no power supplied by these terminals. This circuit is rated for 30 Vac at 1 A. The mating connector is AMP part number 350766-1, which uses male crimp pins, AMP part number 350218-1. The AMP pins are designed for specific wire gauges, so choose the appropriate wire. Other connectors will fit these jacks, including solder-cup and “IDC” style connectors.

Pin #	Description
3	Common (C)
2	Normally Open (NO)
1	Normally Closed (NC)

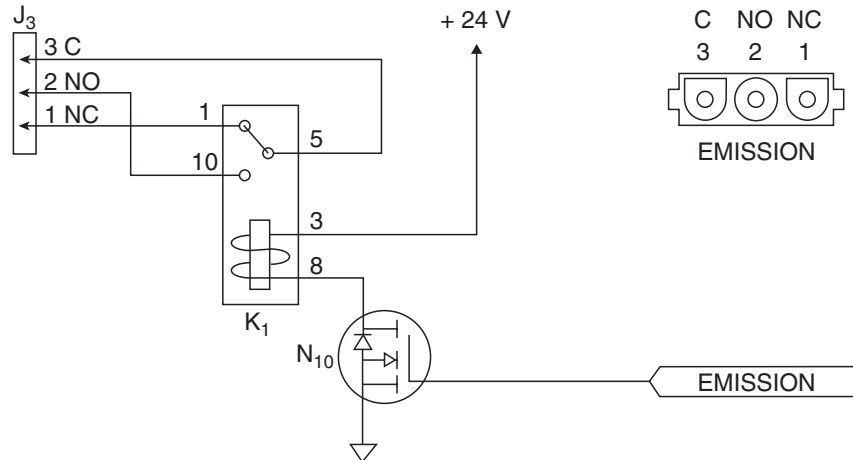

Figure 4-5: Emission Connector Circuit

Safety INTERLOCK Connector

This is a system interlock that must be closed for operation. The plug provided with the system can be replaced with a connector that is wired to auxiliary safety equipment (such as a door switch) to stop laser emission when actuated (the switch is opened).

When the interlock is open, the shutter in the laser head closes immediately, blocking laser emission. Note that the diode pump laser remains on and that laser radiation is still present in the laser head. The shutter can be opened and laser operation restored to normal once the interlock fault has been cleared. The laser power level will be at the set value displayed in small characters on the power supply LCD.

The switch connected to this interlock must be designed for a 12 V 100 mA signal. The mating connector is AMP part number 350777-1, which uses female crimp pins, AMP part number 350536-1. The AMP pins are designed for specific wire gauges, so choose the appropriate wire. Other connectors will fit these jacks, including solder-cup and “IDC” style connectors.

Pin #	Description
1	System Interlock
2	System Interlock Return

This chapter provides detailed instructions and information for the initial planning and setup of the *Centennia TD* system hardware. If you have not set up the laser before, or you are moving the laser system to a new location, please review this section in detail.

Be sure to follow all recommended safety precautions while handling or storing the laser. Be sure to install all laser safety devices before using the laser or offering it for use. Refer to Chapter 2, “Laser Safety” for more information on these topics.

The power supply, chiller and laser head together typically produce less than 500 W (1.7 kBTU per hour) of waste heat; a maximum value is about 1100 W (3.6 kBTU per hour). Provide enough room cooling capacity to prevent overheating.

Installing the Laser Head

The laser head should be secured to an optical table or other flat mounting surface. Three slots are provided in the bottom edge of the mounting base for this purpose, two near the output bezel and one at the center rear. Three laser head clamps are supplied that can be used on tables with either metric 175 mm hole spacing or English 1 inch spacing.

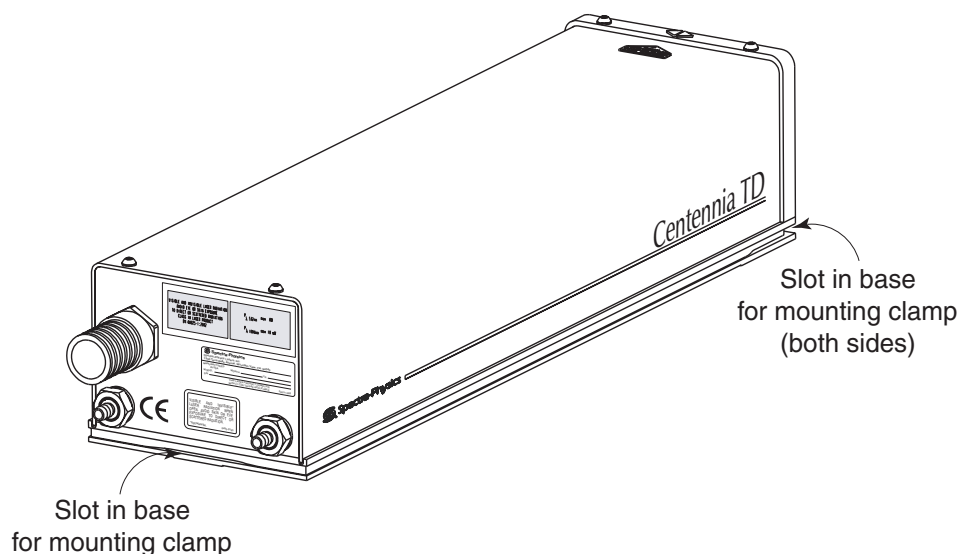

Figure 5-1: Base Slots for Mounting Clamps

To mount the laser head for general use, secure the laser head to the table by inserting the three laser head clamps (provided) into the slots in the mounting base as shown in Figure 5-1. Then, using table mounting screws along with the nested spherical washers (also provided), fasten the laser to the table using the desired mounting holes.

If ordered as the pump source for a *Tsunami* laser, the height of the output beam from the *Centennia TD* must be raised so that it can be input to the *Tsunami*. The *Tsunami* comes with a set of legs that will adjust the *Centennia TD* output to the correct height. Instructions for mounting the *Centennia TD* using these legs are given below.

1. If the *Centennia TD* will be used to pump a Spectra-Physics *Tsunami*[®] laser, screw the 3 legs included in the *Tsunami* accessory kit into the holes shown in Figure 5-2 until they are secure. The 3.5 in. legs raise the laser off the table to a beam height of approximately 5.8 in. (14.8 cm).

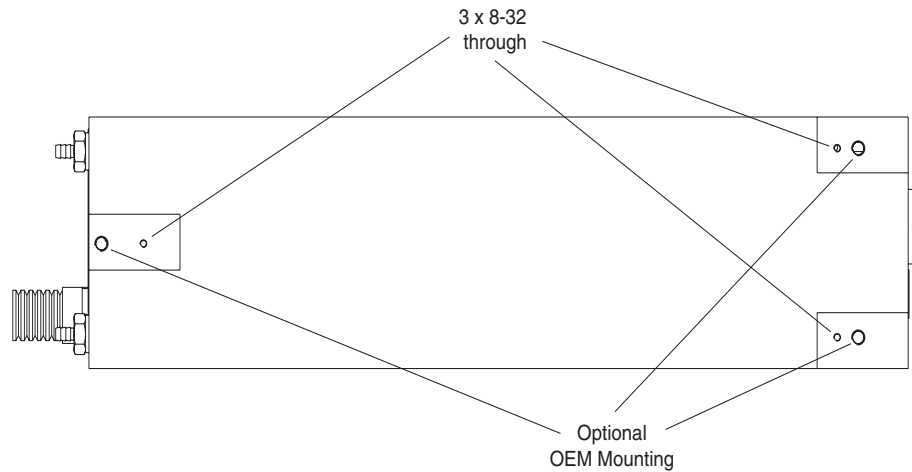

Figure 5-2: Location of leg mounting holes on bottom of laser head (the second set of holes is for OEM use only).

2. Clamp the legs in place with the 3 foot-clamps provided with the legs. Slide the U- shaped clamp end over the foot of each leg, place a table mounting screw through the slot, and fasten the leg to the table.

Installing the Power Supply



Caution!



Provide at least 6 inches of clearance from the front and back of the *Centennia* power supply to allow cool air to enter the front and heated exhaust air to exit the rear panel. Inadequate cooling will cause the system to overheat and shut down. Damage to components caused by insufficient cooling is not covered by the warranty.

Mounting the Power Supply as a Stand-Alone Unit

Place the power supply in a convenient location within 4 m of the laser head (the length of the umbilical). Be careful that the heat generated by the power supply does not adversely affect the laser.

Ensure that the electrical cables and umbilical are safely routed and not under any strain or compression. Use caution when moving the laser head to ensure that the umbilical does not snag and pull the laser head to the floor. Do not step on or roll objects over the umbilical.

Mounting the Power Supply in a Standard Rack

An optional kit is available to mount the power supply into a standard 19 in. (48.3 cm) enclosed rack. Place the rack in a convenient location less than 4 m (the length of the umbilical) from where the laser head will be located. Be careful that the heat generated by the power supply will not adversely affect the laser.

Disconnect the umbilical from the power supply. Slide the power supply into the rack, rear panel first, and onto the support structure (shelf or rails). Fasten the front panel of the power supply to the rack using the screws provided.



Caution!



These front panel screws are only meant to secure the power supply in place, *not to support it*. Provide slides or rails to support the weight of the power supply.

Installing the Chiller

Refer to the user's manual that came with your chiller for detailed information on installing and starting the chiller.



Caution!



Do not place the chiller above the laser, the power supply or other delicate or electrical components. If the chiller develops a leak, dripping water may damage these components.

Mount the chiller on the floor, table top or in a rack as appropriate. The *Centennia TD* system is shipped with metric dimension water hoses, which are about 4 m in length, already attached to the laser head. Position the chiller close enough to the laser head so that the cooling hoses from the laser head can reach the connections on the back of the chiller.

If you chose to use your own recirculating chiller, it must meet the requirements of the *Centennia TD* in order to protect the laser from damage and to ensure its performance.

The output of the chiller should be 3 to 3.5 liters per minute of distilled water, filtered to 100 μm or smaller, at a temperature of $20 \pm 0.5^\circ\text{C}$. The maximum allowable water pressure at the laser head inlet is 5 bar. Refer to Table 3-5, "Chiller Requirements" on page 3-13 for English units.

Connecting the System

Refer to the interconnect drawing, Figure 5-3 and the connector locations shown in Figure 5-4.

1. Plug the umbilical connector into the socket of the power supply and tighten it.

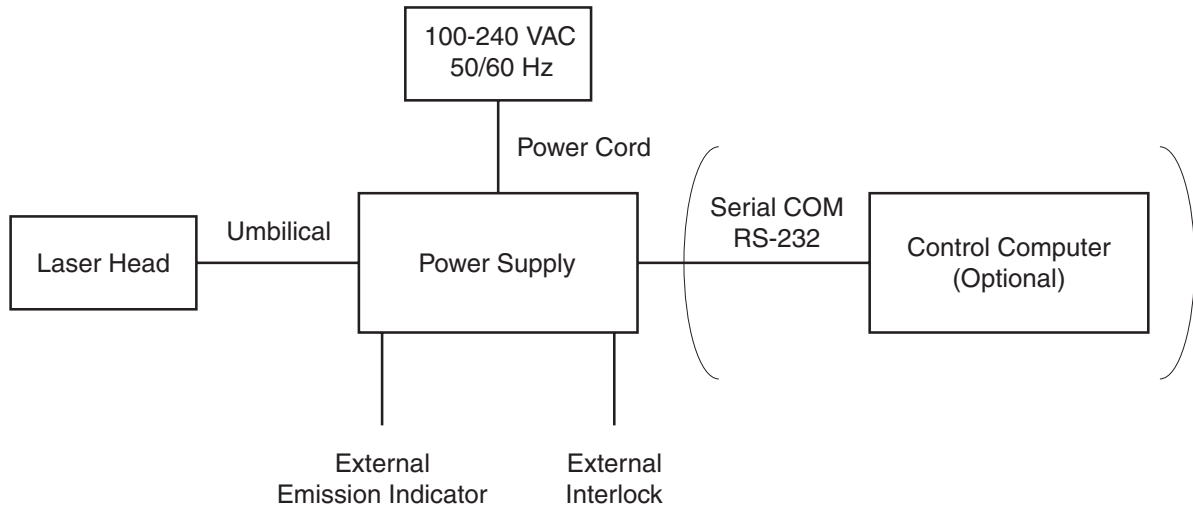

Figure 5-3: Centennia TD Interconnect Drawing

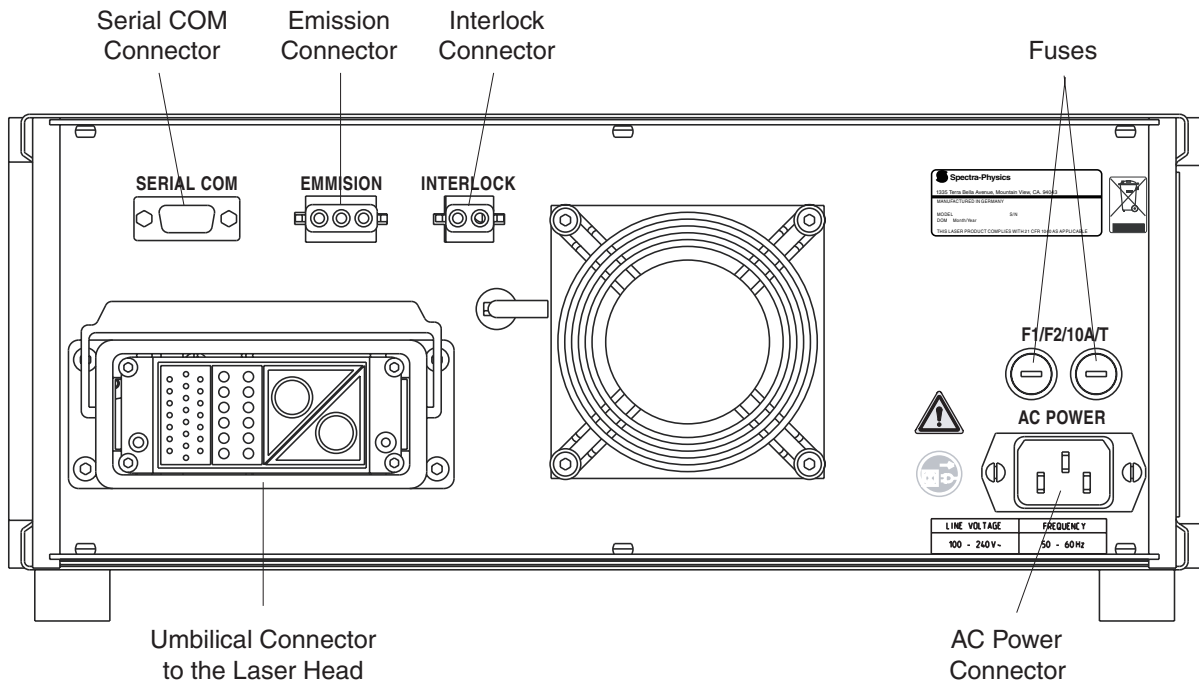

Figure 5-4: Power Supply Rear Panel

2. If an emission indicator lamp is required, in addition to those on the laser head and the power supply front panel, use the EMISSION relay connector on the rear panel of the power supply to turn a lamp on and off. Refer to “EMISSION Connector” on page 4-5 for information on how to wire and use this optional relay-driven indicator.
3. Attach the provided IEC power cord to the connector on the power supply and fasten it to the receptacle, using retaining screws so that it cannot pull out. Plug the other end of the cord into a facility power outlet that can supply 100 to 240 Vac, 15 A single phase power.
A Schuko type plug is provided for European operation. If you received a plug inappropriate for your area, call your Spectra-Physics regional distribution center to obtain the correct one (see Chapter 8, “Customer Service” for telephone numbers).
4. Verify that the correct fuses are in place for the power supply. Refer to “Specifications” on page 3-11.
5. Connect both metric water hoses from the laser head to the chiller. The hose connections are not polarized.
6. Verify the water level in the chiller, and then turn it on. Verify that water is flowing and that there are no leaks at the hose connections.
7. Set the chiller temperature to 20°C (68°F).

This completes the installation of the *Centennia TD* system.

Note

For information on how to use the serial interface on the power supply to control the *Centennia TD* system, contact Spectra-Physics.

Moving the System

To move the system, disconnect the chiller supply lines at the chiller and drain the lines. Follow the directions included in the chiller manual for handling the coolant. Note that if the coolant water contains an algicide, it is likely to be classified as a hazardous material.

If only a small cart is available to move the system, the laser head can be placed on top of the power supply on the cart. Balance the laser head carefully as it is considerably longer and heavier than the power supply. Be careful that the umbilical or water hoses do not snag while moving the laser head. Move the chiller separately from the laser head and power supply.

Make sure the cooling lines are reconnected and tightly fastened to the chiller before restarting the laser after moving it. Take care to properly refill the chiller and laser head with coolant.

Alignment

There is no alignment procedure for the *Centennia TD* laser system: there are no knobs to adjust or optics to align. Refer to Chapter 6, “Operation” when you are ready to turn on the laser.



The Spectra-Physics *Centennia TD* laser is a *Class IV—High Power Laser* whose beam is, by definition, a safety and fire hazard. Take precautions to prevent accidental exposure to both direct and reflected beams. Diffuse as well as specular beam reflections can cause severe eye or skin damage.

Please read this entire chapter and Chapter 2, “Laser Safety” before using your laser for the first time.

System Startup and Shutdown

The *Centennia TD* is operated in a straightforward manner using the controls and the LCD display on the power supply.

Turning the Laser On

1. Verify that all connections are properly attached to the power supply and laser head (they should already be connected—if they are not, refer to Chapter 5, “Installation” for instructions on reconnecting them).
2. Turn on the chiller if it is not on already. Verify that it is set to 20°C. Refer to the chiller user’s manual for instructions.
3. Set the AC rocker switch on the power supply front panel to ON.
 - a. The green POWER LED illuminates on the front panel.
 - b. The LCD screen displays the Spectra-Physics logo during the brief boot-up procedure.
 - c. After system boot, the Main LCD screen appears and displays “0.00W” and “Laser Off”.

4. Turn the LASER ENABLE keyswitch to ON.

Note



If the keyswitch is already ON when the AC power is turned on, the laser will not start. Cycle the keyswitch OFF and then ON to start the laser.

- a. The green READY LED on the front panel blinks.
At this point, laser radiation is present inside the laser head. There is an initial spike in power as the diode pump laser is turned on and settles to its operating level. Note that the shutter is closed at this point and all laser radiation is contained within the laser head.
 - b. The advancing status bar on the LCD shows the progress of the warm-up process. The warm-up will take approximately 1 minute, depending on recent use of the system and its environment.
 - c. When the system is ready for operation, the READY LED glows continuously, the status bar is completely filled, and the LCD reads “Laser On”.
5. If the yellow ERROR indicator illuminates, turn the keyswitch off. Check the system connections and make certain that the chiller is set correctly and is operating properly. Refer to Chapter 7, “Maintenance and Troubleshooting,” for more information on diagnosing problems. Once the underlying problem has been corrected, cycle the AC power off and on. Turn the keyswitch on again.

If the fault is still present, contact your Spectra-Physics representative.



The next step will open the shutter and emit the laser beam. Before proceeding, be certain that the beam will be properly terminated by a power detector or other suitable beam block.

6. To begin laser emission, press and hold in the START button for at least 1 second. Pressing the START button initiates the 3 second CDRH emission delay, during which time the yellow emission indicators blink on the laser head and on the power supply.

The shutter opens after the 3 second delay, and the EMISSION indicators on the laser head and power supply now glow steadily.

7. From a cold start, laser power is initially set to zero. Set the desired power level using the dial on the *Centennia* power supply. The laser emits its green laser beam at a power level ≥ 0.5 W.

The setting appears in small characters on the power supply LCD screen. The actual power output, as measured by the internal control loop, is displayed in large characters.

Note that, when the shutter is opened, output power will be at the setting displayed on the LCD. The power setting selected before the shutter is opened determines the initial output power.

Turning the Laser Off

1. Close the shutter by pressing STOP button. This blocks laser emission, but laser radiation remains present inside the laser head. The EMIS- SION indicators on the laser head and power supply turn off.
2. Turn the LASER ENABLE keyswitch on the power supply to OFF. This terminates laser radiation. The READY indicator on the power supply will turn off. Remove the key to prevent unauthorized use.
3. Turn the AC power ON/OFF switch on the power supply to OFF. This shuts off electrical power to the power supply. The green POWER indi- cator will turn off.
4. If the system is not going to be used for some time (for example, over- night), turn the chiller off. Otherwise it is recommended that the chiller be left on to reduce the warm-up time.



Caution!



Neither the power supply nor the laser head of the *Centennia TD* system contain user serviceable parts. The laser head in particular has been assembled in a clean, controlled environment; the sealed inner cavity is filled with an inert gas. *Removing the outer covers from either the laser head or power supply will void the warranty.*

Maintenance

The *Centennia TD* laser head requires no routine maintenance. *There is no reason to remove the outer cover from the laser head; there are no user-serviceable parts inside the laser!* The cavity mirrors are permanently fixed in their optimum alignment at the factory using Spectra-Physics patented technology. Realigning the cavity optics in the field is not necessary; alignment at the factory is performed using special tooling.

To retain a clean intracavity environment, all components are cleaned to stringent standards prior to assembly and alignment at the factory. The interior of the laser is filled with an inert gas and the cover is sealed. It can only be removed by an authorized service engineer in an environment specified for cleanliness, humidity, and temperature. *Removing the sealed cover in the field will compromise the cleanliness of the intracavity space, allow the inert gas to escape, degrade laser performance, and void the warranty!*

Replacing the diode module in the laser head is not permitted except when performed by someone trained by Spectra-Physics. Call your Spectra-Physics service representative when you suspect a low-power diode module or when its optical fiber is damaged, and the diode module needs replacement.

All parts that normally come in contact with laboratory or industrial environments retain surface contamination that can be transferred to optical components during handling. Indeed, skin oils can be very damaging to optical surfaces and coatings and can lead to serious degradation problems under intense laser illumination. It is therefore essential that only clean items come into contact with the optical components and the mechanical parts immediately surrounding them that are used in conjunction with the *Centennia TD* laser.

Troubleshooting

Service Training Programs

The *Centennia TD* diode-pumped, solid state laser is designed for hands-off operation. This product does not require alignment or routine cleaning of cavity optics. Repair is generally limited to replacing the entire laser head or the power supply. Unauthorized repair will void the warranty.

Spectra-Physics offers service training programs to train personnel in the diagnosis of problems and service of the system. These programs are tailored to suit the needs of the customer and can be conducted on site or at our factory. For more information or to schedule a training program, contact your sales representative.

Troubleshooting Guide

If an interlock is activated or a system failure occurs, current to the diode pump laser in the laser head is turned off. The yellow ERROR LED on the front panel of the power supply will illuminate, and the LCD screen will display an error code that may be helpful in diagnosing the problem. To clear the error status, turn off the keyswitch, correct the underlying problem, and then cycle the AC power off and back on.

Likely causes of an error indication are the activation of one of the safety interlocks, such as an optional door switch, or the temperature of the cooling water exceeding the preset protective limit.

This troubleshooting guide is for use by you, the customer. It is provided to assist you in isolating some of the problems that might arise while using the system. A complete repair procedure is beyond the scope of this manual. For information concerning the repair of your unit by Spectra-Physics, please call your local service representative. A list of world-wide service sites is included in “Service Centers” on page 8-3.

Symptom: Low power

Possible Causes	Corrective Action
The beam is clipped.	Call your Spectra-Physics service representative.
The chiller is not turned on or there is poor or no water flow.	Verify that the chiller is turned on and its reservoir is full. Make sure all the water fittings are connected. Check the chiller's filter screen at the pump and clean it if necessary. Refer to the chiller manual.
The diode pump laser is nearing its end of life.	Call your Spectra-Physics service representative.

Symptom: High optical noise.

Possible Causes	Corrective Action
The chiller is not turned on or there is poor or no water flow.	Verify that the chiller is turned on and its reservoir is full. Make sure all the water fittings are connected. Check the chiller's filter screen at the pump and clean it if necessary. Refer to the chiller manual.

Symptom: Bad mode.

Possible Causes	Corrective Action
The beam is clipping the output telescope assembly.	Call your Spectra-Physics service representative.

Symptom: The *Centennia TD* shuts itself off in power mode.

Possible Causes	Corrective Action
Incorrect pick-off calibration (power readout).	Call your Spectra-Physics service representative.

Symptom: The *Centennia TD* will not lase.

Possible Causes	Corrective Action
The shutter is not open.	Command the shutter to open.
An interlock is either open or has been opened and closed.	Verify that all interlocks are closed before starting the laser.

Symptom: Long-term stability/beam pointing is poor.

Possible Causes	Corrective Action
The laser head is not properly mounted.	Review Chapter 5, "Installation." and verify that the laser head is mounted properly.
The routing mirrors are not installed correctly.	If routing mirrors are used as part of the beam delivery setup, ensure that they are assembled and locked down correctly.

Customer Service

At Spectra-Physics, we take great pride in the reliability of our products. Considerable emphasis has been placed on controlled manufacturing methods and quality control throughout the manufacturing process. Nevertheless, even the finest precision instruments will need occasional service. Our instruments have excellent service records compared to competitive products, and we strive to provide excellent service to our customers in two ways: by providing the best equipment for the price, and by servicing your instruments as quickly as possible.

Spectra-Physics maintains major service centers in the United States, Europe, and Japan. Additionally, there are field service offices in major United States cities. When calling for service inside the United States, dial our toll free number: **1 (800) 456-2552**. To phone for service in other countries, refer to “Service Centers” on page 8-3.

Order replacement parts directly from Spectra-Physics. For ordering or shipping instructions, or for assistance of any kind, contact your nearest sales office or service center. You will need your instrument model and serial numbers available when you call. Service data or shipping instructions will be promptly supplied.

To order optional items or other system components, or for general sales assistance, dial **1 (800) SPL-LASER** in the United States, or **1 (650) 961-2550** from anywhere else.

Warranty

All parts and assemblies manufactured by Spectra-Physics are unconditionally warranted to be free of defects in workmanship and materials for the period of time listed in the sales contract following delivery of the equipment to the FOB point.

Liability under this warranty is limited to repairing, replacing, or giving credit for the purchase price of any equipment that proves defective during the warranty period, provided prior authorization for such return has been given by an authorized representative of Spectra-Physics. Spectra-Physics will provide at its expense all parts and labor and one-way return shipping of the defective part or instrument (if required).

In-warranty repaired or replaced equipment is warranted only for the remaining portion of the original warranty period applicable to the repaired or replaced equipment.

This warranty does not apply to any instrument or component not manufactured by Spectra-Physics. When products manufactured by others are included in Spectra-Physics equipment, the original manufacturer's warranty is extended to Spectra-Physics customers. When products manufactured by others are used in conjunction with Spectra-Physics equipment, this warranty is extended only to the equipment manufactured by Spectra-Physics.

This warranty also does not apply to equipment or components that, upon inspection by Spectra-Physics, is found to be defective or unworkable due to abuse, mishandling, misuse, alteration, negligence, improper installation, unauthorized modification, damage in transit, or other causes beyond the control of Spectra-Physics.

This warranty is in lieu of all other warranties, expressed or implied, and does not cover incidental or consequential loss. This warranty is valid for units purchased and used in the United States only. Products shipped outside the United States are subject to a warranty surcharge.

Returning the Instrument for Repair

Contact your nearest Spectra-Physics field sales office, service center, or local distributor for shipping instructions or an on-site service appointment. You are responsible for one-way shipment of the defective part or instrument to Spectra-Physics.

Use the original packing boxes to secure instruments during shipment. If shipping boxes have been lost or destroyed, we recommend ordering new ones. Instruments can be returned only in Spectra-Physics containers.

Removing Water from the System

Warning!



Always drain the cooling water from the laser head and chiller before shipping. Freezing may occur at high altitudes in the cargo hold of an aircraft and can cause damage. Such damage is not covered by warranty.

To drain the laser head:

1. Turn off the laser system and chiller.
2. Disconnect the laser head cooling lines from the chiller and allow the lines to drain into a bucket.
3. Use a shop vacuum or similar device to suck out any water that might remain in the laser head.

Because the cooling circuit in the laser head is designed to operate at less than about 70 psi (5 bar), *do not use high-pressure air to blow it out*. Doing so can dislodge water seals in the laser head and damage it. *Such damage is not covered under your warranty.*

To drain the chiller, refer to the chiller user manual for detailed instructions. Note that the cooling water may contain chemicals that are classified as hazardous materials.

Service Centers

Benelux

Telephone: (31) 40 265 99 59

France

Telephone: (33) 1-69 18 63 10

Germany and Export Countries*

Spectra-Physics GmbH
 Guerickeweg 7
 D-64291 Darmstadt
 Telephone: (49) 06151 708-0
 Fax: (49) 06151 79102

Japan (East)

Spectra-Physics KK
 East Regional Office
 Daiwa-Nakameguro Building
 4-6-1 Nakameguro
 Meguro-ku, Tokyo 153
 Telephone: (81) 3-3794-5511
 Fax: (81) 3-3794-5510

Japan (West)

Spectra-Physics KK
 West Regional Office
 Nishi-honmachi Solar Building
 3-1-43 Nishi-honmachi
 Nishi-ku, Osaka 550-0005
 Telephone: (81) 6-4390-6770
 Fax: (81) 6-4390-2760
 e-mail: niwamuro@splasers.co.jp

United Kingdom

Telephone: (44) 1442-258100

United States and Export Countries**

Spectra-Physics
 1330 Terra Bella Avenue
 Mountain View, CA 94043
 Telephone: (800) 456-2552 (Service) or
 (800) SPL-LASER (Sales) or
 (800) 775-5273 (Sales) or
 (650) 961-2550 (Operator)
 Fax: (650) 964-3584
 e-mail: service@spectra-physics.com
 sales@spectra-physics.com
 Internet: www.newport.com/Lasers

* And all European and Middle Eastern countries not included on this list.

** And all non-European or Middle Eastern countries not included on this list.

Notes

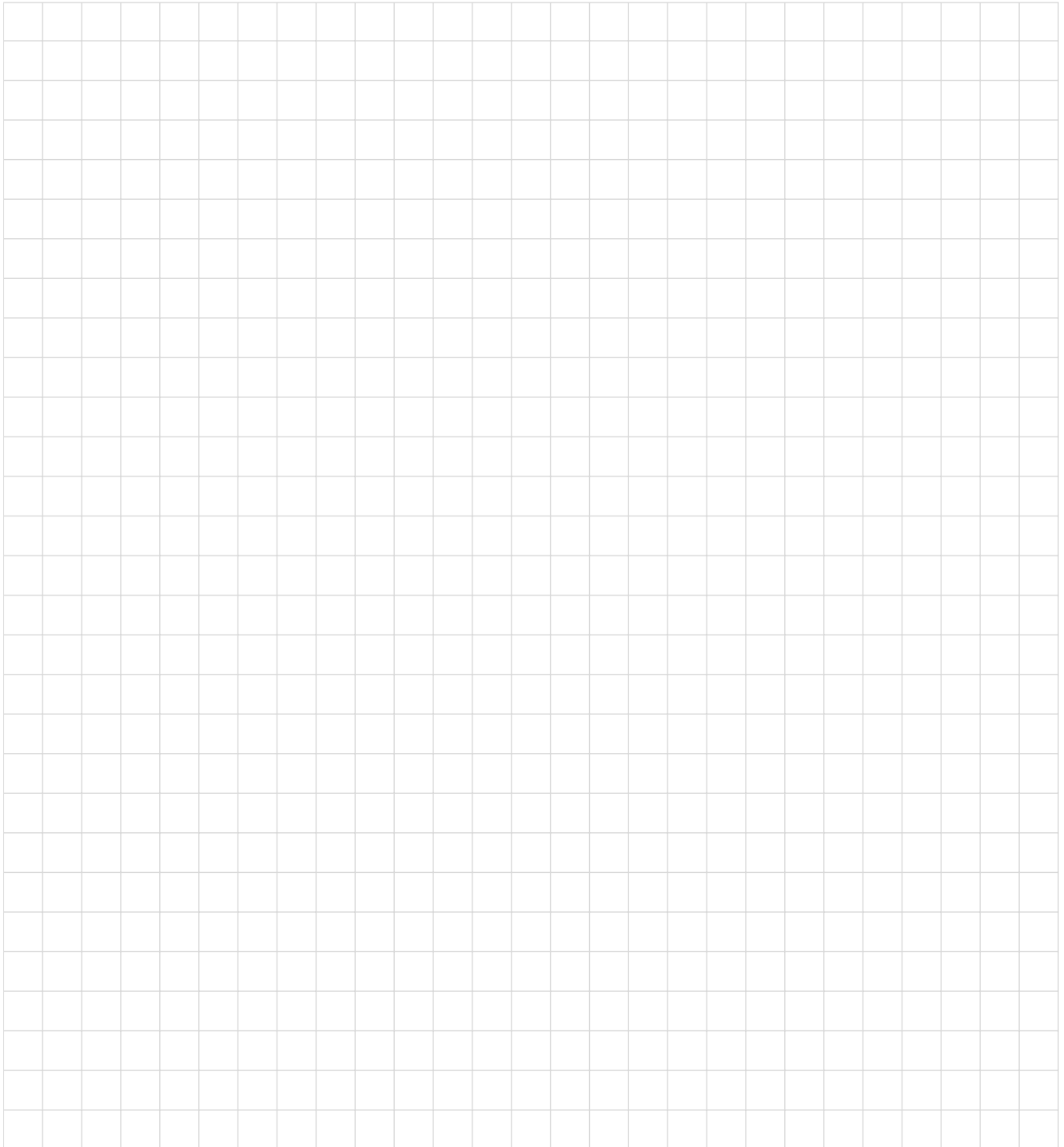

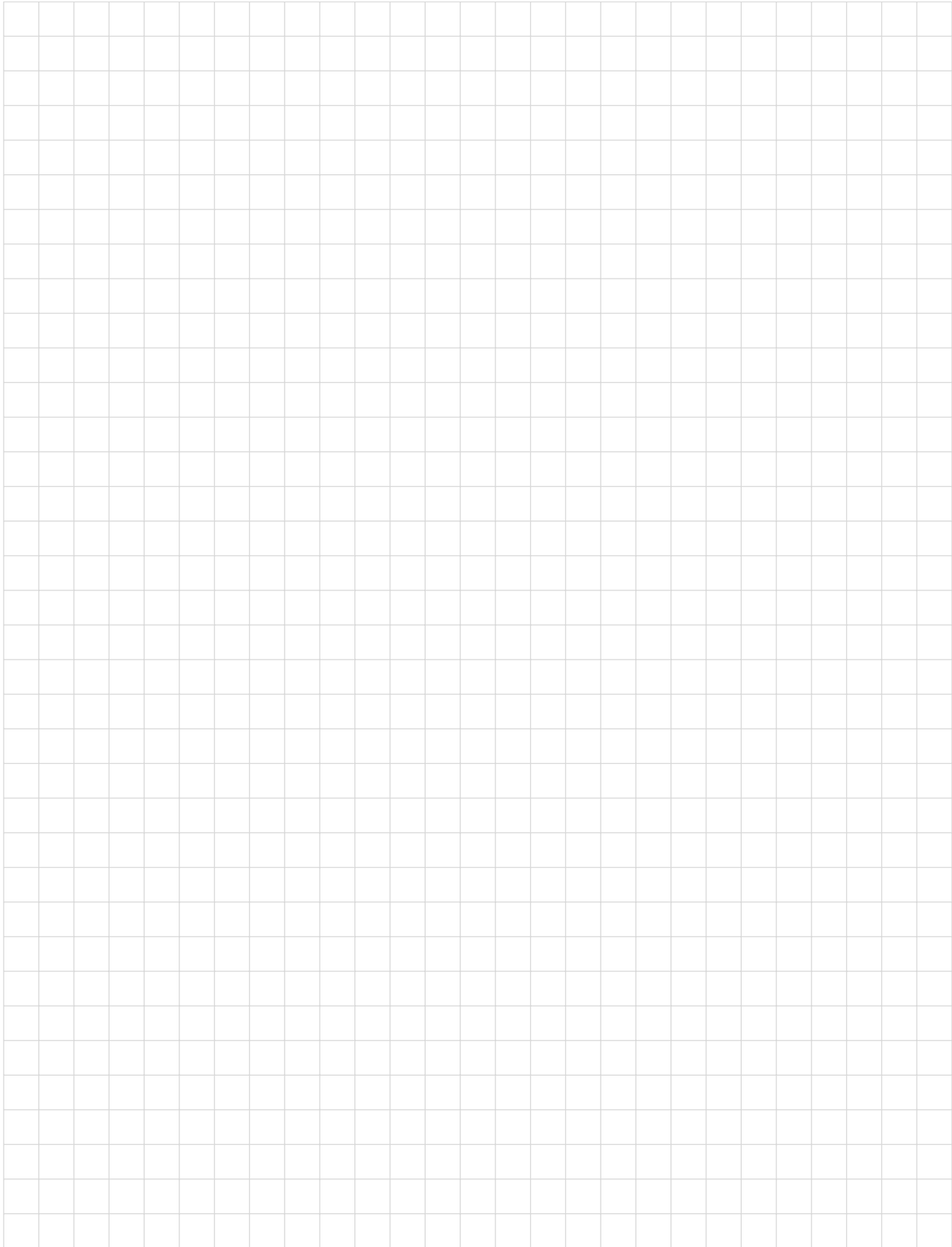

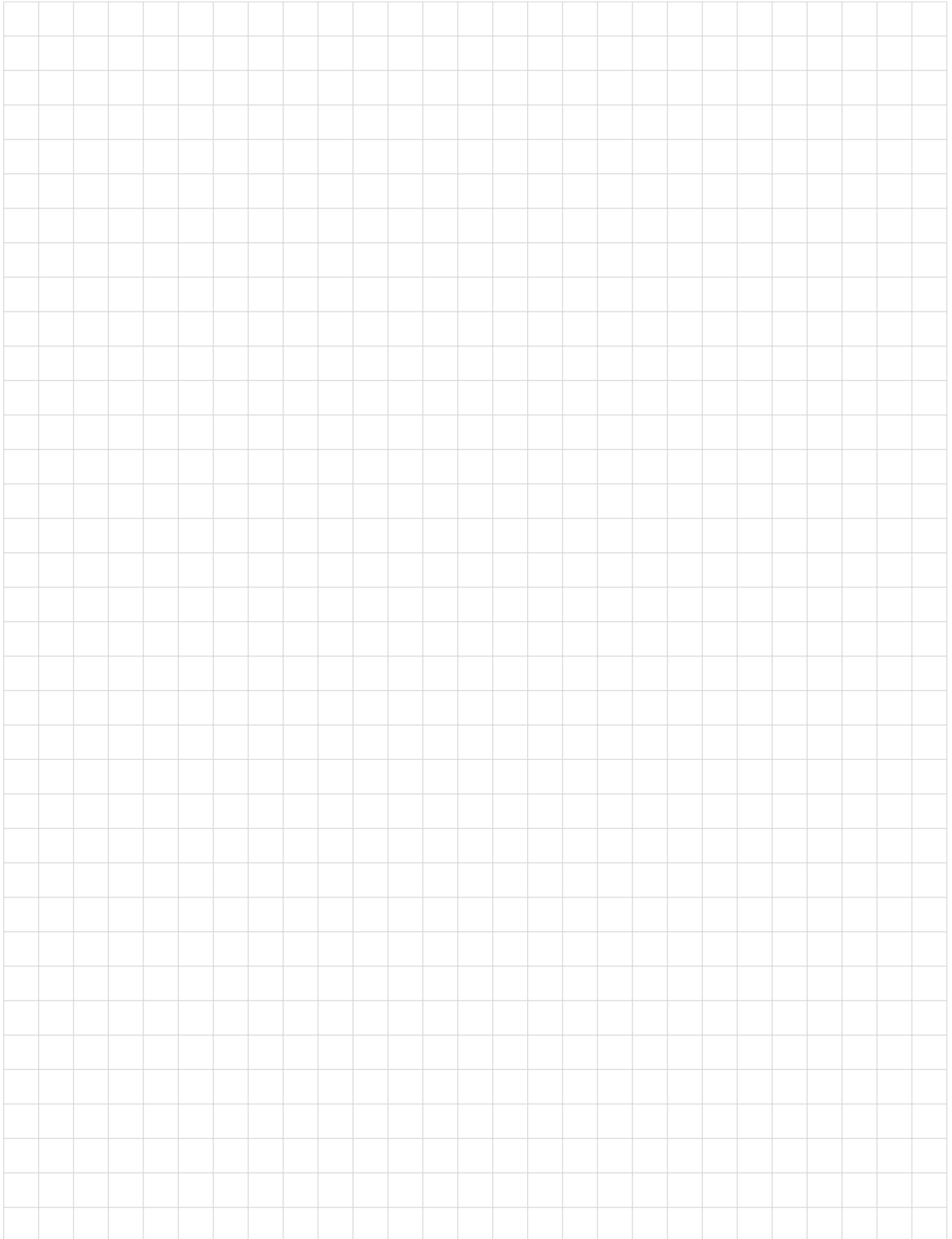

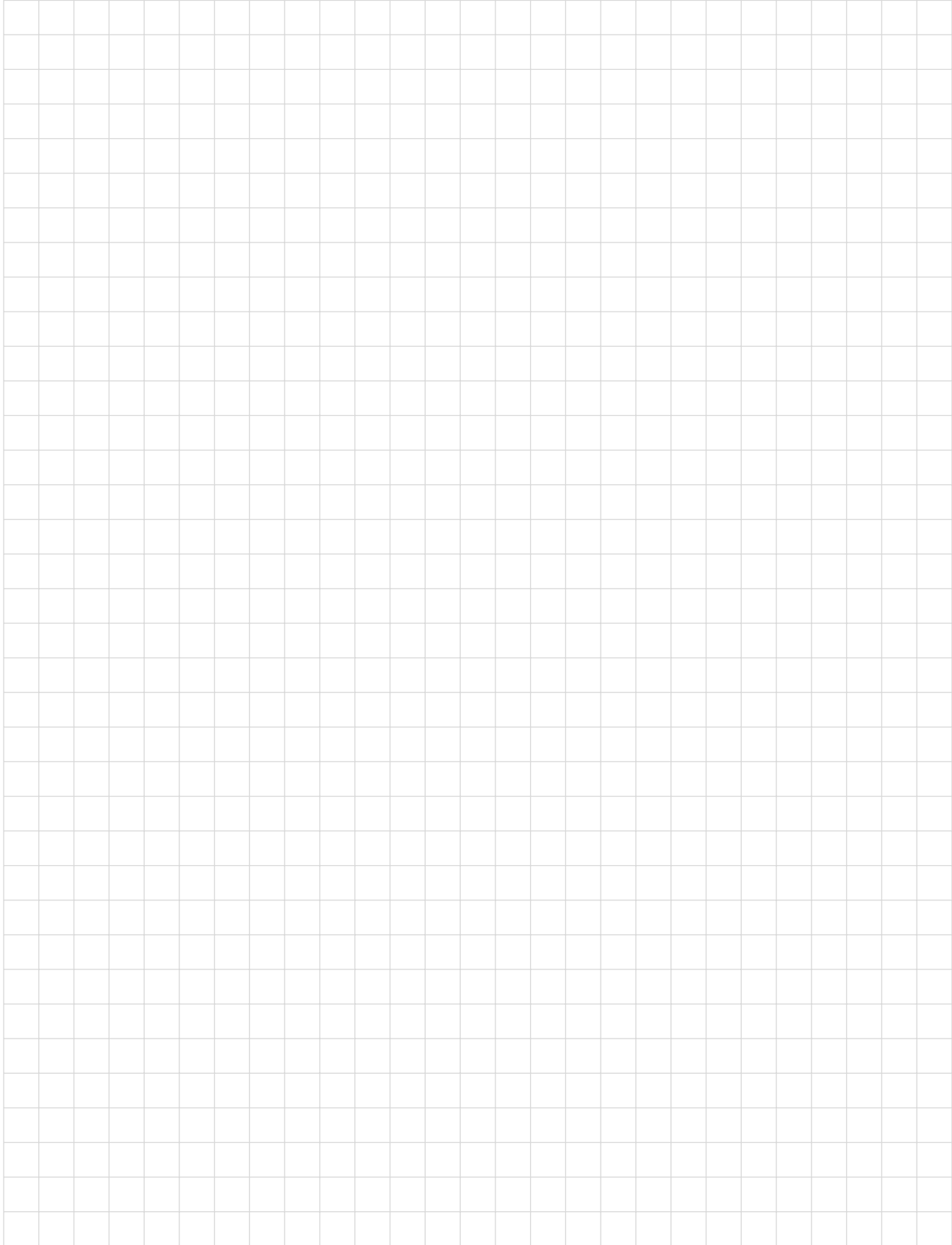

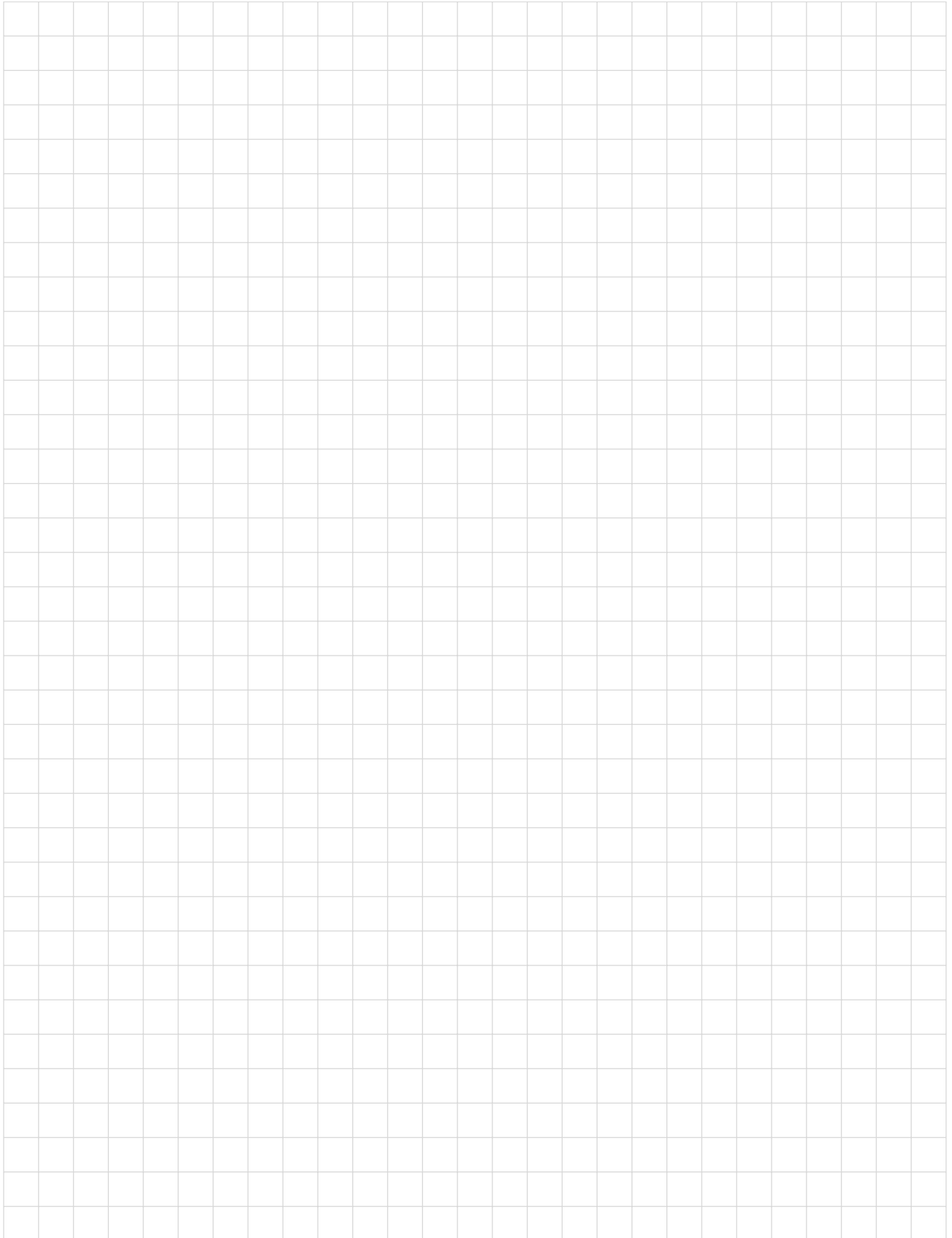

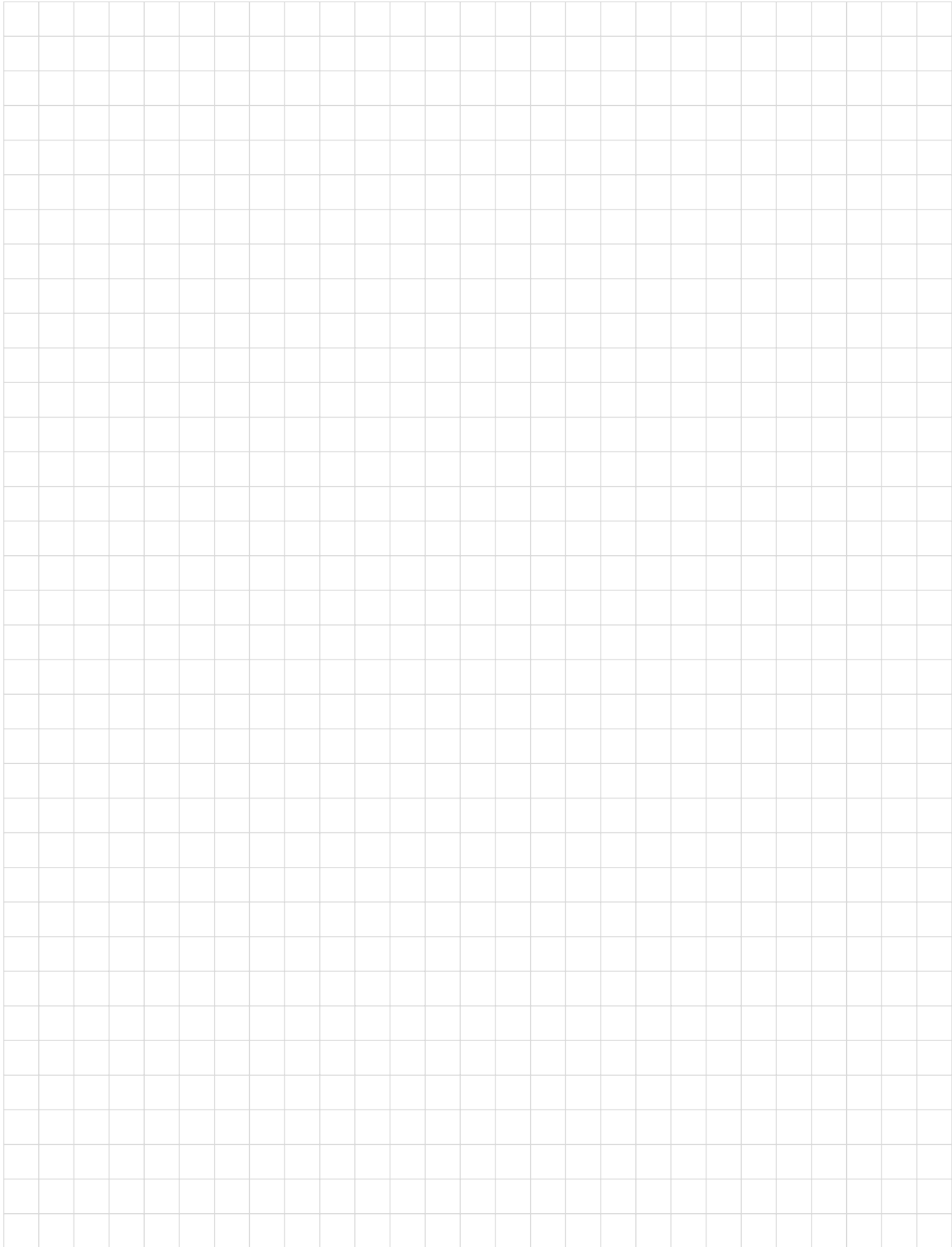

Report Form for Problems and Solutions

We have provided this form to encourage you to tell us about any difficulties you have experienced in using your Spectra-Physics instrument or its manual—problems that did not require a formal call or letter to our service department, but that you feel should be remedied. We are always interested in improving our products and manuals, and we appreciate all suggestions.

Thank you.

From:

Name _____

Company or Institution _____

Department _____

Address _____

Instrument Model Number _____ Serial Number _____

Problem: _____

Suggested Solution(s): _____

Mail To:

Spectra-Physics, Inc.
SSL Quality Manager
1330 Terra Bella Avenue, M/S 15-50
Post Office Box 7013
Mountain View, CA 94039-7013
U.S.A.

E-mail: sales@spectra-physics.com
www.newport.com/lasers

FAX to:

Attention: SSL Quality Manager
(650) 961-7101

