

# Lantech

---

## IRC-0101 RS-232/422/485 TO TCP/IP CONVERTER

### User Manual



# Table of Contents

<b>1. Introduction</b>	<b>3</b>
Overview	4
Package Checklist	4
Block Diagram	5
Features	6
Product Specifications	7
<b>2. e-NET TCP/IP Converter Description</b>	<b>9</b>
Product Panel Views	9
Top Side	9
Right Side	9
Left Side	10
Rear Side	10
LED Indicators	11
Wiring Architecture	12
RS-232	12
RS-422/RS-485	12
<b>3. e-NET TCP/IP Converter Installation</b>	<b>13</b>
Power Supply	13
Ethernet Port	13
Serial Port	14
Rs-485/RS-422 Port	14
Dip Switch	14
Reset	14

<b>4. e-NET TCP/IP Converter Configuration</b>	<b>16</b>
Initial IP Configuration	16
Device Management Utility of ETM	16
Menu “View”	18
Menu “Config”	18
Web Console Configuration	20
Controller Status	21
Controller Setup	24
Controller Updated	30
Factory Default Setting	31
<b>5. Setting Verification</b>	<b>32</b>
Hyper Terminal for TCP/IP WinSock	33
Hyper Terminal for COM Port	38
Data Transmission	39
<b>Appendix A - FAQ</b>	<b>40</b>
<b>Appendix B - Pin Outs and Cable Wiring</b>	<b>41</b>
B.1 DC-In Jack	41
B.2 RJ-45 Pin Assignment	41
B.3 RS-232 Pin Assignment	41
B.4 RS-232 Wiring Diagram	42
B.5 RS-422 Pin Assignment	42
B.6 RS-422 Wiring Diagram	42
B.7 RS-485 Wiring Diagram	42
<b>Appendix C Troubleshooting Guide</b>	<b>43</b>
<b>Appendix D Firmware Upgrade</b>	<b>44</b>

We provide new ways of connecting legacy serial devices to a Local Area Network (LAN) or Wide Area Network (WAN). TCP/IP converters are designed to operate serial ports over 100Mbit/s Ethernet networks. The data is transmitted via TCP/IP protocol. Therefore control is available via Ethernet, Intranet and Internet. IRC-0101 converter is packaged in a PVC material case well suited for industrial environments. There are provided two serial ports as one is a RS-232 and other one is RS-422/485 (Auto-Detection). All serial ports operate in common industrial configuration.

IRC-0101 converter is a low-cost, high performance design. By careful selecting high quality with competitive prices components in the world, the products made network connectivity possible with affordable cost for virtually all kinds of devices.

IRC-0101 converter Series consists of three models: IRC-0101-M is a module product for developing purpose by customers. IRC-0101-S14 is a full set converter device within one serial port of RS-232 and four socket connection ports. IRC-0101 is a full set converter device within two serial ports as one is a RS-232 port and other one is a RS-422/485 (Auto-Detective) and it provides one socket connection port. This operation manual will guide you step by step for the various functions of the IRC-0101 converter.

The following topics are covered in this chapter:

- ❑ **Overview**
- ❑ **Block Diagram**
- ❑ **Product Features**
- ❑ **Product Specifications**

## Overview

Model IRC-0101 converter is designed to make your industrial serial devices Internet ready instantly. ARM-Cortex-M3 CPU of IRC-0101 converters makes them the ideal choice for connecting your RS-232 and RS-422 or RS-485 serial device—such as PLCs, meters, and sensors—to an IP-based Ethernet LAN, making it possible for your software to access serial devices anywhere and anytime over a local LAN or the Internet.

ARM-Cortex-M3 CPU Series converters ensure the compatibility of network software that uses a standard network API (Winsock or BSD Sockets) by providing TCP Server Mode, TCP Client Mode, and UDP Mode. Model IRC-0101 is provided 1 socket connection for remote management. ARM-Cortex-M3 CPU Series' Virtual COM driver, software that works with COM port can be set up to work over a TCP/IP network in no time. This excellent feature preserves your software investment and lets you enjoy the benefits of networking your serial devices instantly.

ARM-Cortex-M3 CPU series converters support manual configuration via the handy web browser console and many protocols including TCP, IP, UDP, HTTP, DHCP, TELNET, and ARP. They are the best solution to network your serial devices.

## Package Checklist

ARM-Cortex-M3 CPU products are shipped with the following items:

- ❑ 1 unit of e-NET TCP/IP converter
- ❑ 1 unit of Power Adaptor (9V DC, 500mA)
- ❑ Documentation & Software CD
- ❑ Quick Installation Guide

NOTE: Notify your sales representative if any of the above items is missing or damaged.

## Block Diagram

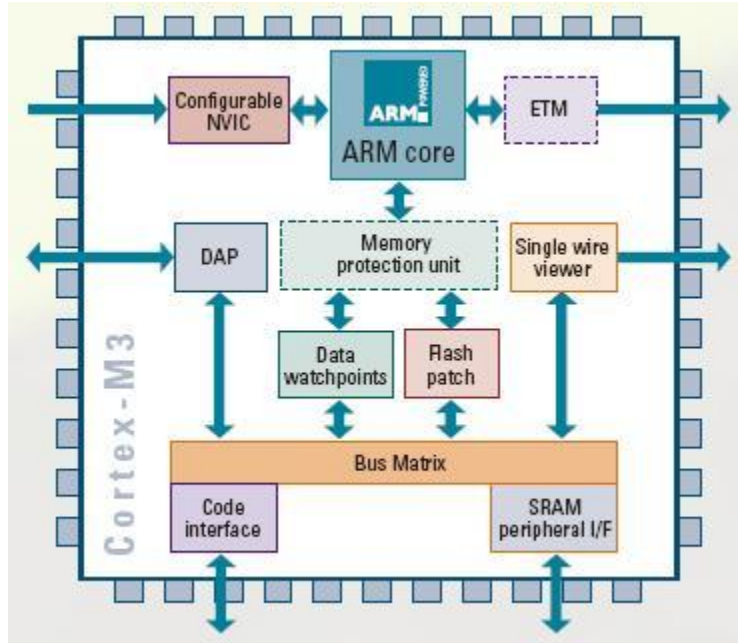

Low-cost devices usually are equipped with low speed processors and limited memories. In reality, they are neither having the capability nor practicality to manage complicated network TCP/IP protocols. The ARM Cortex™-M3 32-bit processor has been specifically developed to provide a high-performance, low-cost platform for a broad range of applications including microcontrollers, automotive body systems, industrial control systems and networking by converting data stream between network TCP/IP and popular serial port signals.

In stead of processing TCP/IP packets directly, devices need only deal with those interface signals, which greatly simplifies the complexity of TCP/IP network in linkage. The Cortex-M3 processor provides outstanding computational performance and exceptional system response to interrupts while meeting low cost requirements through small core footprint, industry leading code density enabling smaller memories, reduced pin count and low power consumption.

The central core of the Cortex-M3 processor, based on a 3-stage pipeline Harvard bus architecture, incorporates advanced features including single cycle multiply and hardware divide to deliver an outstanding efficiency of 1.25 DMIPS/MHz. The Cortex-M3 processor also implements the new Thumb®-2 instruction set architecture, which when combined with features such as unaligned data storage and atomic bit manipulation delivers 32-bit performance at a cost equivalent to modern 8- and 16-bit devices.



## Product Features

- ❑ **Data Conversion between RS-232 and RS-422/485 and Ethernet**  
IRC-0101 converter device (RS-232 \* 1 port , RS-422 / 485 \* 1 port ) data/signal into the TCP/IP package data/signal and send them out with the Ethernet DataStream; or convert the TCP/IP package data/signal into serial device data/signal.
- ❑ **Socket Communication**  
E-P132-X-S21 is provided one socket connection.
- ❑ **Digital I/O Activating**  
E-P132-X-S21 is provided eight TTL of digital I/O.  
Convert the sensors' statuses (the sensors are connected to the converter) into the TCP/IP package data and send them out with the Ethernet DataStream; or use the TCP/IP package data to activate/deactivate the specified digital outputs.
- ❑ **Dynamic IP Configuration**  
Support DHCP client mode, simplifying network address configuration and management.
- ❑ **Dual LAN Speed**  
Support 10/100 Mbps Ethernet, auto-detected.
- ❑ **Server / Client Dual Modes**  
E-P132-X-S21 converter device can be configured as network server or network client. In the client mode, it can be installed in network which is protected by NAT router or firewall, without the need of a real IP address.
- ❑ **Web-based Setup**  
Parameters setup is based on HTTP protocol by using standard browsers (IE , Netscape and Telnet). No special software would be required.
- ❑ **Built-in Security Control**  
Security protected is by login password to prevent intruders.
- ❑ **Remote Reprogramming**  
Firmware can be reprogrammed directly via Ethernet network to keep up with latest network standards.

## Product Specifications

- CPU : ARM Cortex™-M3 32-bit processor , 50MHz
- RAM : 64K Bytes SRAM
- ROM : 256K Bytes Flash ROM
- Ethernet
  - Port Type : RJ-45 Connector
  - Speed : 10 /100 M bps ( Auto Detecting )
  - Protocol : ARP, IP, ICMP, UDP, TCP, HTTP, DHCP, TELNET
  - Mode : TCP Server / TCPIP Client / UDP Client
  - Setup : HTTP Browser Setup (IE & Netscape)
  - Security : Login Password
  - Protection : Built-in 1.5KV Magnetic Isolation
- Serial Port
  - No. of Ports : RS-232 \* 1 Port and RS-422/485(Auto-Detective) \* 1 Port
  - Port Type : DB9 male
  - Speed : 300 bps~115.2k bps
  - Parity : None , Odd , Even, Mark, Space
  - Data Bit : 5,6,7,8
  - Stop Bit : 1 , 2
  - Port 1 :
    - One RS-232 Signals Port : Rx , Tx , GND , RTS , CTS , DTR , DSR , DCD
  - Port 2 :
    - One RS-422 / 485 Port (Auto-Detective)
    - RS-422 Signals : Rx+ , Rx- , Tx+ , Tx- (Surge Protection)

- RS-485 Signals : Data+ , Data- (Surge Protection)
- Built-in RS422/RS485 Pull High / Low Resistor
- Digital I/O Port
  - Digital I/O \* 8 TTL
- Socket Port Connection : 1 Connection
- 15KV ESD for all signal
- Watch Dog Function
- Virtual Support Windows 2000 /2003 / XP
- Firmware On-line Updated Via Ethernet
- Power : DC 9 – 12 V , 500mA
- LED Lamp :
  - PWR (Green)
  - DATA (Red-Blink during data transferring and receiving)
  - LAN (Red for 10 Mbps ; Green for 100 Mbps)
  - SYS (Red-Blink)
- Environment :
  - Operating Temperature : 0°C ~70°C
  - Storage Temperature : -10°C ~85°C
- Dimensions : 90 \* 60 \* 20 mm ( W \* D \* H )
- WEIGHT : 65 gm
- RoHS : Compliant with RoHS
- Regulatory Approvals : FCC Class A, CE Class A ?
- WARRANTY : 1 year

# Converter Description & Installation

## Product Panel Views

### Top Side



### Right Side

#### Serial I/O Port of RS-232 and RS-422/485

Connect the serial data cable between the converter device and the serial devices. Follow the parameter setup procedures to configure the converter (see the following chapters ).

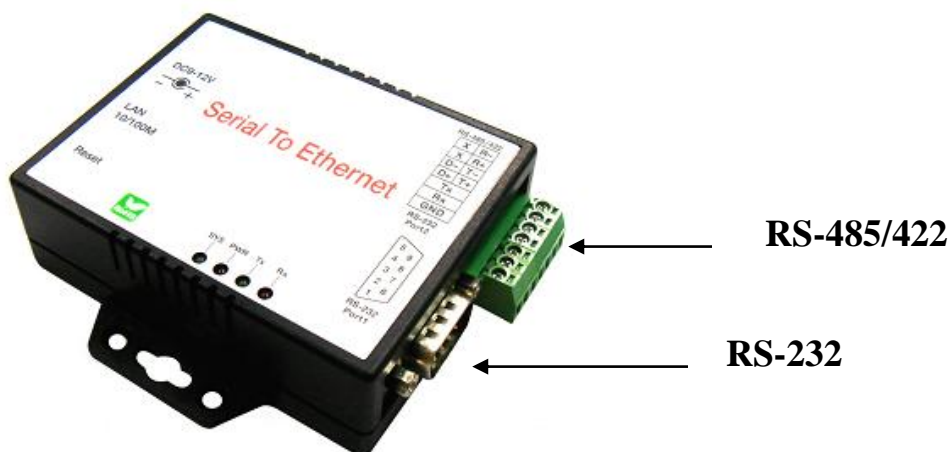

## **Digital I/O**

Transforming the sensor which connecting on the e-Net TCP/IP converters equipment statuses into the TCP/IP package data and send out by the Ethernet DataStream ( The e-Net TCP/IP converters must indicate the IP address and Com Port) or activating the indicated Digital output (Remote WinSock must indicate the e-Net TCP/IP converters)Connect the data wires between the e-Net TCP/IP converters and the RS-485/RS-422 device. Follow the parameter setup procedures to configure the converter (see the following chapters).

## Left Side

### Power Supply

IRC-0101-S14 TCP/IP converter device is powered by a single 9Vdc (inner positive/outer negative) power supply and 500mA of current. A suitable power supply adapter is part of the packaging. Connect the power line to the power jack at the left side of IRC-0101-S14 TCP/IP converter device and put the adapter into the socket. If the power is properly supplied, the “PWR” red color LED will be on..

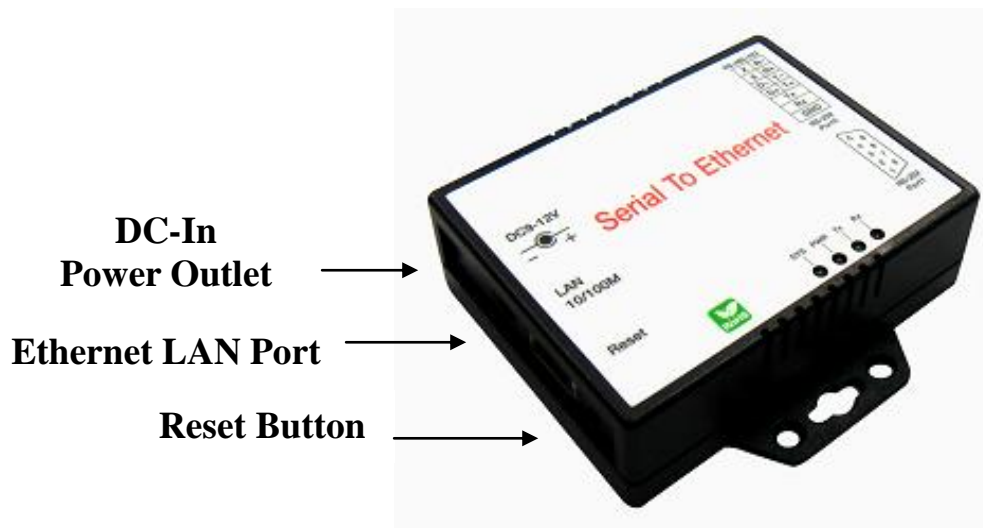

### Ethernet LAN Port

The connector for network is the usual RJ45. Simply connect it to your network switch or Hub. When the connection is made, the LAN LED indicator will light. When data traffic occurs on the network, red DATA LED indicator will blink during data transferring and receiving.

### Reset Button

If by any chance, you forget the setup password, or have incorrect settings making e-Net TCP/IP converter inoperable. First, turn off the power. Second, use any point tip to push this button and hold it to turn on the power at the same time for 5 second. All the parameters will be reset to the factory default.

## LED Indicators



### **PWR (Red):**

It is a power indicator (When the power is on, the LED will be on.)

### **Tx (Green):**

Data sent indicator (When data are sending to the network, the LED will blink.)

### **Rx (Red):**

Data received indicator (When data are receiving to the network, the LED will blink.)

### **SYS (Green):**

It is a device status indicator (When e-NET TCP/IP converter is operated in normal status, the LED will blink once per second.)

# Wiring Architecture

## RS-232 Wiring Architecture

RS-232 Wiring



RS-232(RTS/CTS) Wiring



RS-232(RTS/CTS , DTR/DSR) Wiring

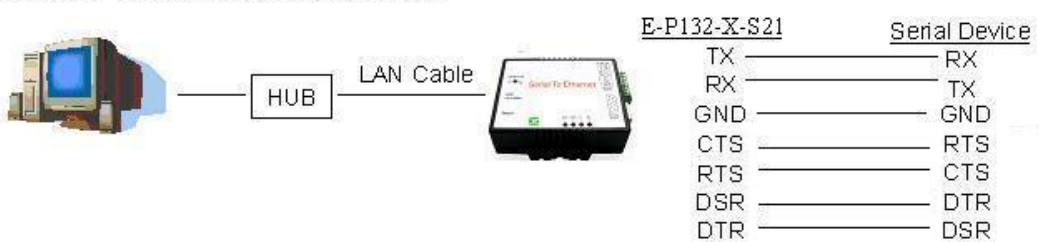

## RS-422/RS-485 Wiring Architecture

RS-422 Wiring



RS-485 Wiring





When you finish the steps mentioned above and the LED indicators are as shown, the converter is installed correctly. You can use the Setup Tool “CVBrowser.exe” to setup the IP Address.

To proceed the advanced parameter setup, please use a web browser (IE or Netscape) to continue the detailed settings.

# Converter Configuration

---

## Initial IP Configuration

When setting up your converter for the first time, the first thing you should do is configure the IP address. This chapter introduces the method to configure the device server's IP address. For more details about network settings, see the Network Settings section in Chapter3, "Web Console Configuration".

The following topics are covered in this chapter:

- ▣ **Device Management Utility**
- ▣ **CVBrowser "View"**
- ▣ **CVBrowser "Modify IP"**
- ▣ **CVBrowser "Modify MAC"**

## Device Management Utility

On PC we provide a Device Management Utility named "**CVBrowser.exe**" which is an executable program in Windows 32 bit environments. CVBrowser setup tool is used to detect and setup the installed converters. It uses UDP broadcast packets to query and configure converters on the network.

When you activate the tool, it will detect the existence of the installed converters and depict the converters' status such as IP address, Subnet Mask, MAC Address, and Device ID (see Figure 3.1). The Setup Tool only can setup one converter at a time. Thus if there are more than one converter on the network, please shut down or disconnect other converters. Otherwise the CVBrowser.exe can not detect the converter.

Due to the nature of broadcast UDP packets, CVBrowser has following characteristics:

- ❑ Broadcast packets are not limited by subnet. Even if the IP address of the converters and the computer running CVBrowser do not belong to the same subnet, it still works fine.
  
- ❑ Broadcast packets can not pass routers. CVBrowser can only be used to monitor devices with computer running CVBrowser in the same segment of local area network.

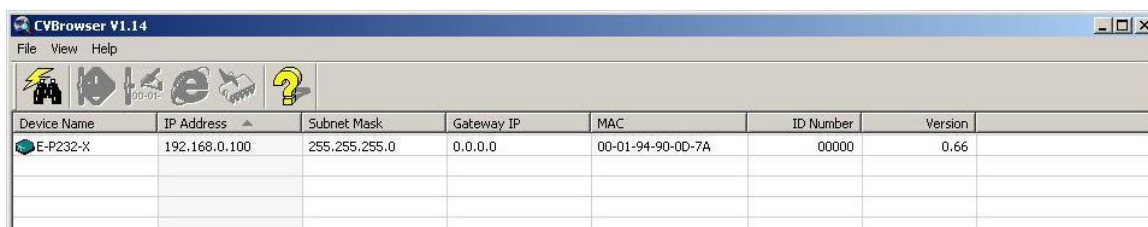

The screenshot shows the CVBrowser V1.14 application window. It has a menu bar with 'File', 'View', and 'Help'. Below the menu bar is a toolbar with several icons: a lightning bolt, a shield, a magnifying glass, a hand, and a question mark. The main area contains a table with the following data:

Device Name	IP Address	Subnet Mask	Gateway IP	MAC	ID Number	Version
E-P232-X	192.168.0.100	255.255.255.0	0.0.0.0	00-01-94-90-0D-7A	00000	0.66

(Figure 3.1)

## CVBrowser “View”

### □ View -> Refresh

There are two ways for refreshing the status of existing devices. You may select the item “**View**” to refresh the status of existing devices on LAN. Other one is to click the icon as red color remark as below. CVBrowser will send another query to get updated information.(see Figure 3.2).

Note: Always run the “**Refresh**” after any data change.

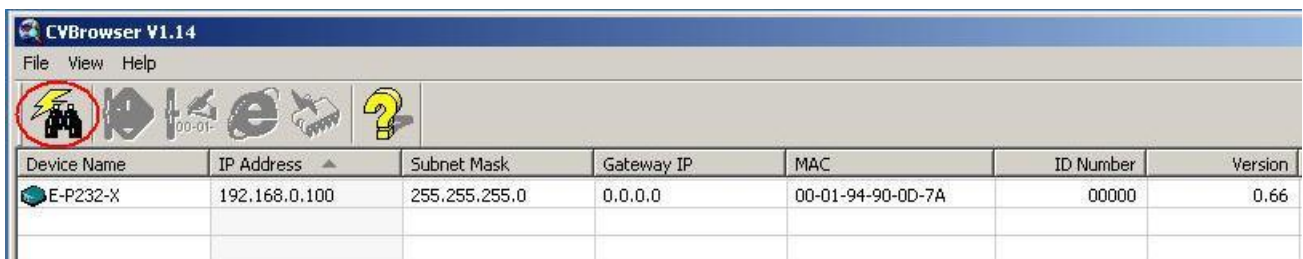

(Figure 3.2)

### □ File -> Exit Alt+F4

Exit from the program (see Figure 3.3).

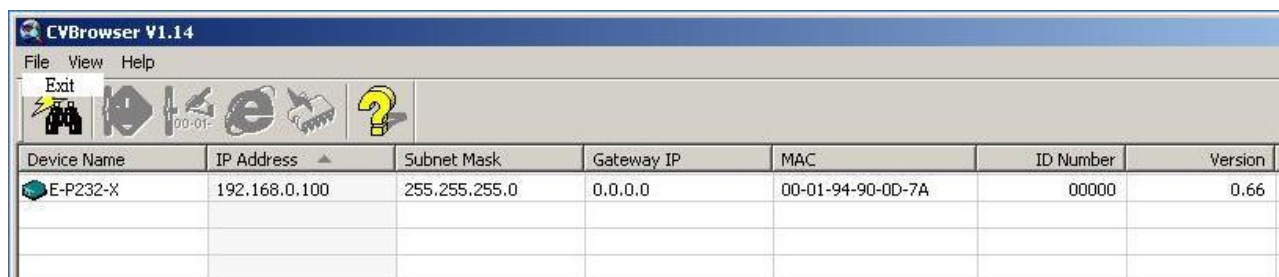

(Figure 3.3)

## CVBrowser “Modify IP”

### □ Modify IP -> Dialog Frame

To click the device on the existing devices list in the CVBrowser table and then the function bar will be enable. To press second icon of “**Modify IP**” on function bar and a dialog frame table will be shown (see Figure 3.4).

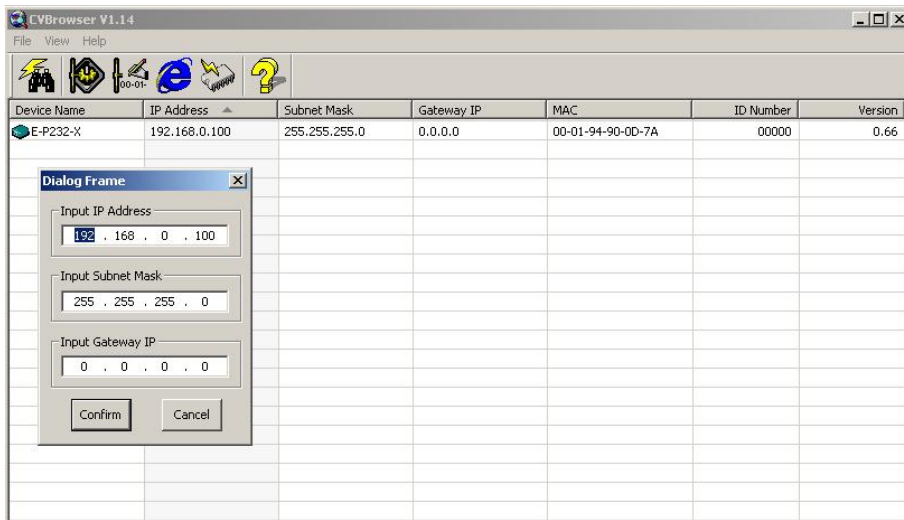

(Figure 3.4)

Assign an IP Address with the same Subnet Mask of your computer, avoiding any IP conflict with other network devices.

When you press “**Confirm**” button, the IP address will be refreshed in 2~3 seconds.

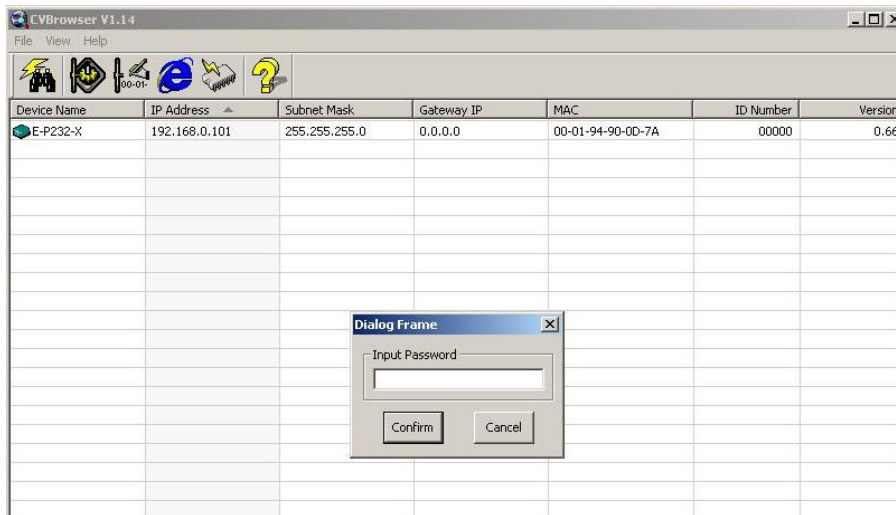

(Figure 3.5)

After click “**Confirm**” button and then “**Input Password**” request will be pop-up on screen(see Figure 3.5). You just press “**Confirm**” button and the new device’s IP will be changed and save in table, if you changed it.

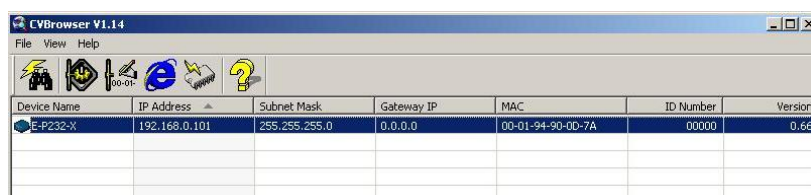

(Figure 3.6)

## CVBrowser “Modify MAC”

### □ Modify MAC -> Dialog Frame

To click the device on the existing devices list in the CVBrowser table and then the function bar will be enable. To press Third icon of “**Modify MAC**” on function bar and a dialog frame table will be shown (see Figure 3.7).

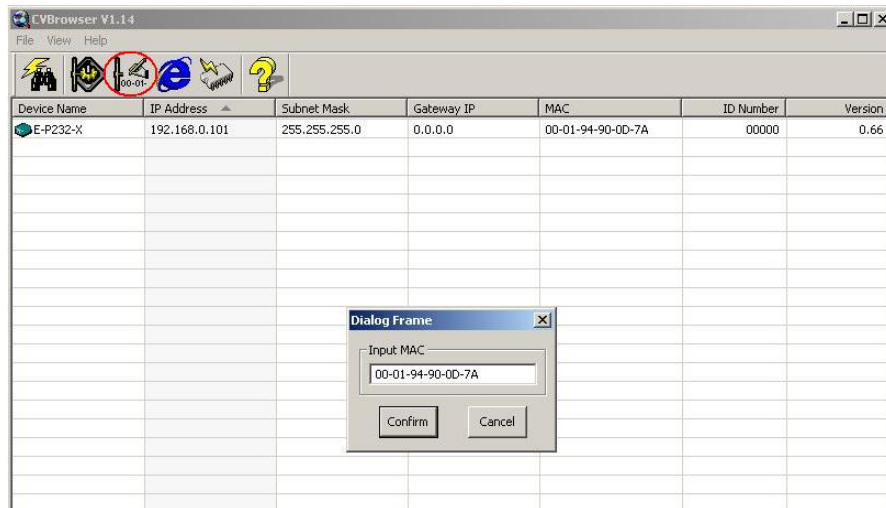

(Figure 3.7)

### □ Input Password -> Dialog Frame

After click “Confirm” button and then “**Input Password**” request will be pop-up on screen (see Figure 3.8). You just press “**Confirm**” button and the new device’s MAC will be changed and save in table, if you changed it.

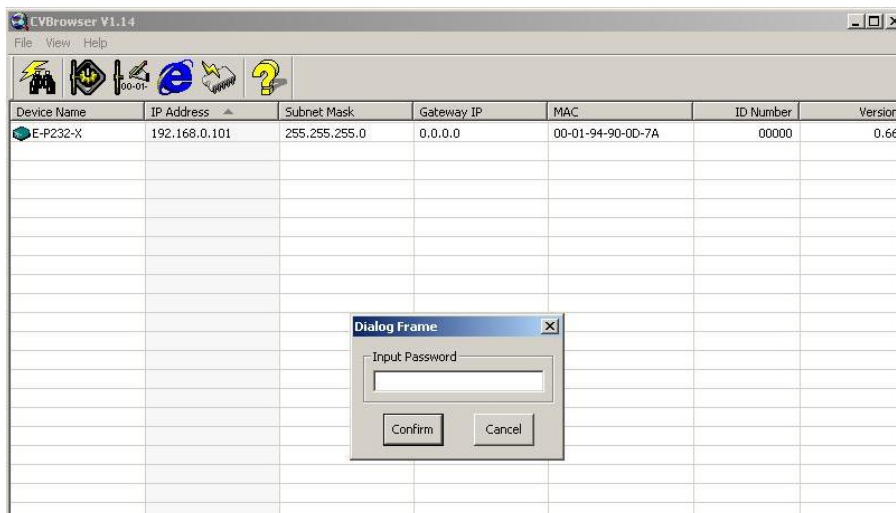

(Figure 3.8)

## Web Browser Configuration

The following topics are covered in this chapter:

- ❑ **Serial To Ethernet Converter Setup**
  - **Login Setting**
  - **Login Setting Page Field Description**
  - **Parameter Setting**
  - **Parameter Setting Page Field Description**

### Login Setting

In addition to basic IP address and subnet mask, specific device settings can be set through HTTP protocol with popular browsers, e.g. Internet Explorer, Netscape, etc. Setup of the converters is as easy as surfing on WWW, no special software will be required.

Setup converter device is as easy as surfing on WWW, no special software will be required. Popular Browsers, such as IE, or Netscape, can easily do the setup process. In the browser URL field, set the IP address of device directly, to enter the “**Login Setting**” page, please follow the steps below.

- ❑ Open your browser. This chapter will use IE as an example.
- ❑ In the browser URL field, type the IP address of the converter directly and press ENTER. (The IP address is what you set using the Device Management Utility as CVBrowser.)
- ❑ To press fourth icon of “**Web Browser**” on function bar and a “**Login Setting**” Screen will be shown (see Figure 3.9) to login into the device.

Alternatively, if the IP address of the converter is already known, you can connect to the converter directly by providing its IP address in the URL field

of browsers.

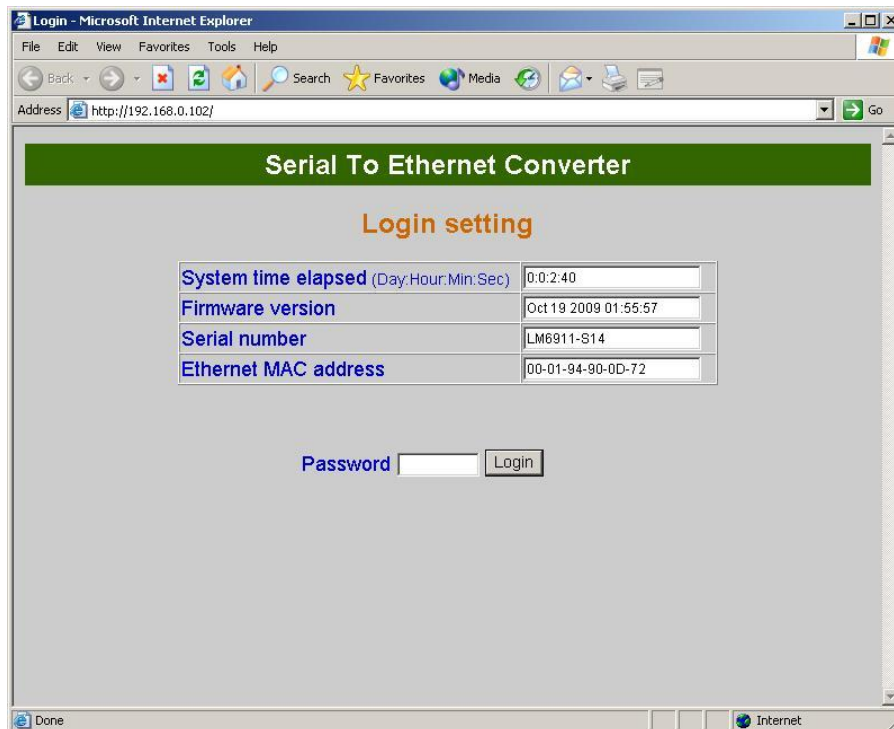

(Figure 3.9)

### Login Setting Page Field Description

- ❑ **System time elapsed**

The time elapsed since start of this device in [Day Hour : Minute : Second] format. This information can be useful in identifying the reliability of system.
- ❑ **Firmware version**

Converter firmware is identified by date code. This information will be required in looking for technical support.
- ❑ **Serial number**

It is a product serial number code in the converter device and has been provided by factory.



#### ❑ **Ethernet MAC Address**

Converter is an unique MAC (Media Access Control) address used by Ethernet in **6 digits**.

#### ❑ **Password**

This field is the administration password for authentication. Factory default is “**empty**”. However, it is not recommended to leave it empty in field operation. If you could not login, it means you have to key in the password. If you do not know the password you can turn off the power and then use any point tip to push “Reset” button and hold it to turn on the power at the same time for **5 seconds**. The password will be reset to the factory default as “**empty**”.

Converter device uses the same password protection mechanism commonly used in Windows NT or UNIX. If there are more than “**3 consecutive failures**” in password check during login, the login function will be disabled for “**15 minutes**”. During this 15 minutes period, even if you supply correct password, login will not proceed. This prevents intruders from finding the password by computer generated program.

## Parameter Setting Page

### ❑ The Parameter Setting Page

Type the correct password in the “**Password**” field and click the “**Confirm**” button in the “**Login Setting**” page, then the “**Parameter Setting**” page will be shown (see Figure 3.10).

Note: If you forget the password or can't login successfully, please contact the manufacturer directly.

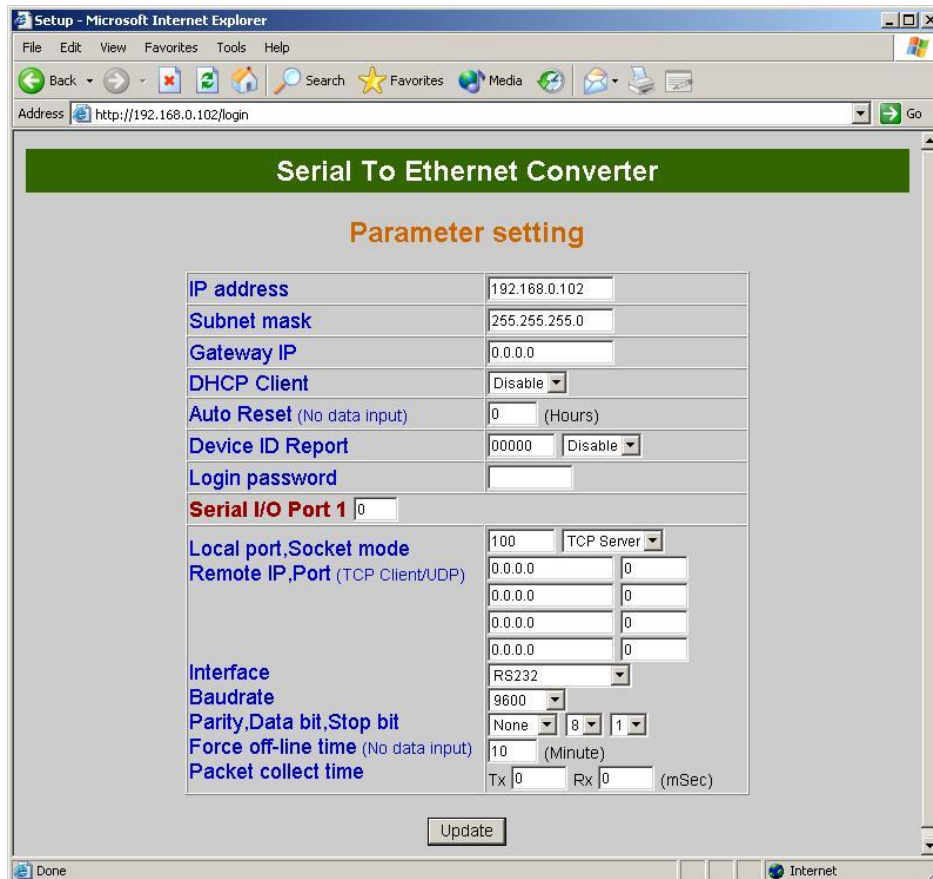

(Figure 3.10)

### ❑ Parameter Setting Page Field Description

#### ❑ IP Address

The IP address of converter device, 4 digits separated by '.' Don't let it conflict with the other devices on the network.

If DHCP client mode is enabled and there's a DHCP server on the network, this field will be assigned by DHCP server automatically.

#### ❑ Subnet mask

Subnet mask of the converter device has connected to. “255.255.255.0” is usually used for small network, “255.255.0.0” for larger network, 4 digits separated by '.'

If your IP address is provided by an ISP or the internal network administrator, please inquire of them that information and type it correctly.

If DHCP client mode is enabled and there's a DHCP server on the network, this field will be assigned by DHCP server automatically.

#### ☐ **Gateway address**

Gateway or Router IP address. 'Gateway' is a device which connects local network to external network. If you need to communicate with other networks or your device owns a real IP address on the internet, please inquire of them that information and type it correctly. If there's no gateway on the network, just leave it as “0.0.0.0”.

If DHCP client mode is enabled and there's a DHCP server on the network, this field will be assigned by DHCP server automatically.

#### ☐ **DHCP client**

DHCP client mode could be enabled/disabled statuses. If DHCP is enabled, there should be a DHCP server on the network. If DHCP is disabled, [IP address], [Subnet mask], and Gateway address] should be manually assigned.

#### ☐ **Auto Reset**

It is for setting when the device has been disconnected or some reasons, the data did not transmit a while. You can prevent it and restart the device after waiting a while (1~99 hours) as your settings.

#### ☐ **Device ID Report ??**

You may “Enable” or “Disable” for collecting the device ID report and assigne ID number for the converter devices. Available ID is “0 ~ 65535”.In TCP mode, if this parameter is enabled, every time when the socket is connected, e-Net TCP/IP converter will immediately report its device ID in the following formats:

Serial #1	nnnnnA[LF][CR]
Serial #2	nnnnnB[LF][CR]

Digital I/O	nnnnnC[LF][CR]
-------------	----------------

The total length is 8 bytes, where “nnnnn” is a 5-digit device ID assigned by the user; [LF] is decimal 10; [CR] is decimal 13.

□ **Login Password**

For security and management issues, you may setup the “Login Password”. This administration password uses to login converter parameter setting pages. It may be empty or up to 15 characters long.

□ **Serial I / O Port 1 (RS-232)**

This converter device model is provided one serial port as RS-232 interface for connecting the extension serial device.

□ **Local Port/Socket Mode/Remote IP & Port**

This converter device is provided 4 socket connections port.

□ **Port number**

A socket port assigned for the serial port. It's a 16-bit numbers, ranging from 1 to 65535. Because the numbers below 1000 are used for specific purposes (e.g. 80 is for HTTP protocol), we suggest you use the numbers larger than **100**. Generally the port number 4660 is used for the serial communication. However you should specify different port number for each serial port.

□ **Socket type**

- TCP Server: TCP protocol, passive open, to be connected from the TCP clients.
- TCP Client: TCP protocol, active open, connect to the TCP server.
- UDP Client: UDP protocol, connectionless

□ **Remote IP address**

The server IP address and socket port would be connected in TCP Server, TCP Client and UDP Client mode for a certain serial port.

□ **Remote socket port**

The server socket port would be connected in TCP Client and UDP Client mode for a certain serial port.

☐ **Interface of serial I/O**

RS232 : TxD, RxD for data stream, no flow control

RS232 (RTS/CTS) : TxD, RxD for data stream, RTS/CTS for flow control.

☐ **Baudrate**

Baud Rate: 300 ~ 460800 bps

☐ **Parity, Data bits, Stop bit**

Parity: None, Even, Odd, Space, Mark.

Data Bits: 5, 6, 7, 8.

Stop Bit: 1 or 2.

☐ **Force off-line time**

It is for setting how long the off-line time of device will be taken when there is no data input. The parameter can be from “0 to 99” and the time unit is “Minute”.

☐ **Packet Collect Time**

It is for setting a packet collecting period of the device serial port’s Tx and Rx. The parameter can be from “0 to 999” and the time unit is “mSec”.

☐ **Serial I / O Port 2 (RS-422/485)**

This converter device model is provided second serial port as RS-422/485 (Auto-Detective) interfaces for connecting the extension serial device.

☐ **Local Port/Socket Mode/Remote IP & Port**

This converter device is provided 1 socket connections port.

☐ **Port number**

A socket port assigned for the serial port. It’s a 16-bit numbers, ranging from 1 to 65535. Because the numbers below 1000 are used for specific purposes (e.g. 80 is for HTTP protocol), we suggest you use the numbers larger than **100**. Generally the port number 4660 is used for the serial communication. However you should specify different port number for each serial port.

- ☐ **Socket type**
  - ☐ TCP Server: TCP protocol, passive open, to be connected from the TCP clients.
  - ☐ TCP Client: TCP protocol, active open, connect to the TCP server.
  - ☐ UDP Client: UDP protocol, connectionless
  
- ☐ **Remote IP address**

The server IP address and socket port would be connected in TCP Client and UDP Client mode for a certain serial port.
  
- ☐ **Remote socket port**

The server socket port would be connected in TCP Server, TCP Client and UDP Client mode for a certain serial port.
  
- ☐ **Interface of serial I/O**

It is provided a “**Auto Detect**” function and just depend on the connected serial device’s interface as RS-422 or RS-485.
  
- ☐ **Baudrate**

Baud Rate: 300 ~ 115200 bps
  
- ☐ **Parity, Data bits, Stop bit**

Parity: None, Even, Odd, Space, Mark.  
 Data Bits: 5, 6, 7, 8.  
 Stop Bit: 1 or 2.
  
- ☐ **Force off-line time**

It is for setting how long the off-line time of device will be taken when there is no data input. The parameter can be from “**0 to 99**” and the time unit is “**Minute**”.
  
- ☐ **Packet Collect Time**

It is for setting a packet collecting period of the device serial port’s Tx and Rx. The parameter can be from “**0 to 999**” and the time unit is “**mSec**”.

## ☐ **Interface of serial I/O**

- ☐ RS232: TxD, RxD for data stream, no flow control
- ☐ RS232 (RTS/CTS): TxD, RxD for data stream, RTS/CTS for flow control
- ☐ RS232 (RTS/CTS, DTR/DSR): TxD, RxD for data stream, RTS/CTS for flow control. DTR for socket status, DSR for socket open/close control
- ☐ RS485 (Half duplex): Half duplex RS-485 interface, RTS for driver enable/disable
- ☐ RS422 (Full duplex): Full duplex RS-422 interface

## Controller Updated

Press “Update”] Button After you finish the detailed parameter setting. The converter will save all parameters into internal non-volatile memory and then reboot (see Figure 5.3). It takes about 5 seconds to complete the whole process, and a new login page will be presented (see Figure 5.1).



(Figure 5.3)

You can re-login and check if all parameters have been correctly saved. If everything is ok, you can close the browser now.

Note : If the domain of the converter is different from that of the computer running the browser, the login page won't appear unless the converter's "Gateway Address" has been correctly set.



## Factory Default Setting

If by chance, you forget the setup password, or have incorrect settings making the converter inoperable, there are two ways to reset the setting and the following procedures can be used to reset all settings to factory default:

A:

1. you can turn off the power and then use any point tip to push “Reset” button and hold it to turn on the power at the same time for **5 seconds**. The password will be reset to the factory default as “**empty**”.

B:

1. Turn off the power of the converter.
2. Use a pin or any point tip to push the screw driver or any conductor to short DTR and CTS (pin 4 and pin 8 in DB9) of RS232 connector.
3. Turn on the power of the converter.
4. Remove screwed driver or conductor.

## Setting Verification

---

After completing the wiring and parameter setting, we should verify if the setting is correct. This chapter will introduce how to use a single computer to test if the converter behaves well.

The operating system can be Windows 95, 98, ME, XP, 2000. The “Hyper Terminal” utility should be installed on your PC (see Figure 6.1). It can be found in your Windows installation CD.

The wiring architecture is similar to “RS-232 Wiring” in chapter 3, and the “Serial Device” is replaced by the PC’s COM 1. The same PC also plays the roll of the Remote Host.

The following topics are covered in this chapter:

- ▣ **Hyper Terminal for TCP/IP WinSock**
- ▣ **Hyper Terminal for COM Port**
- ▣ **Data Transmission**

## Hyper Terminal for TCP/IP WinSock

Initiate a Hyper Terminal from the Start Menu in Windows (see Figure 6.1), give a terminal name, choose an icon, and press “OK” button (see Figure 6.2).

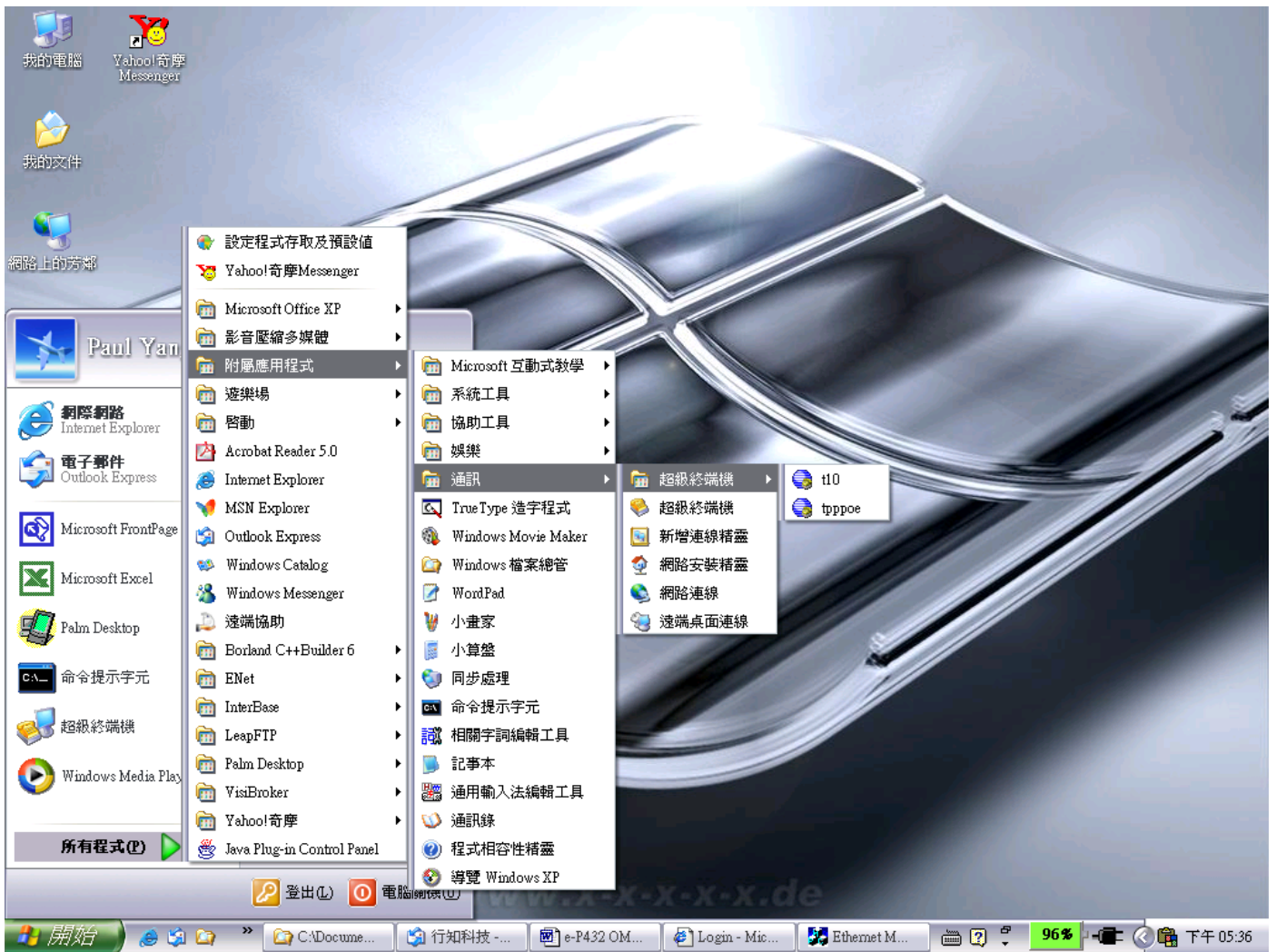

(Figure 6.1)

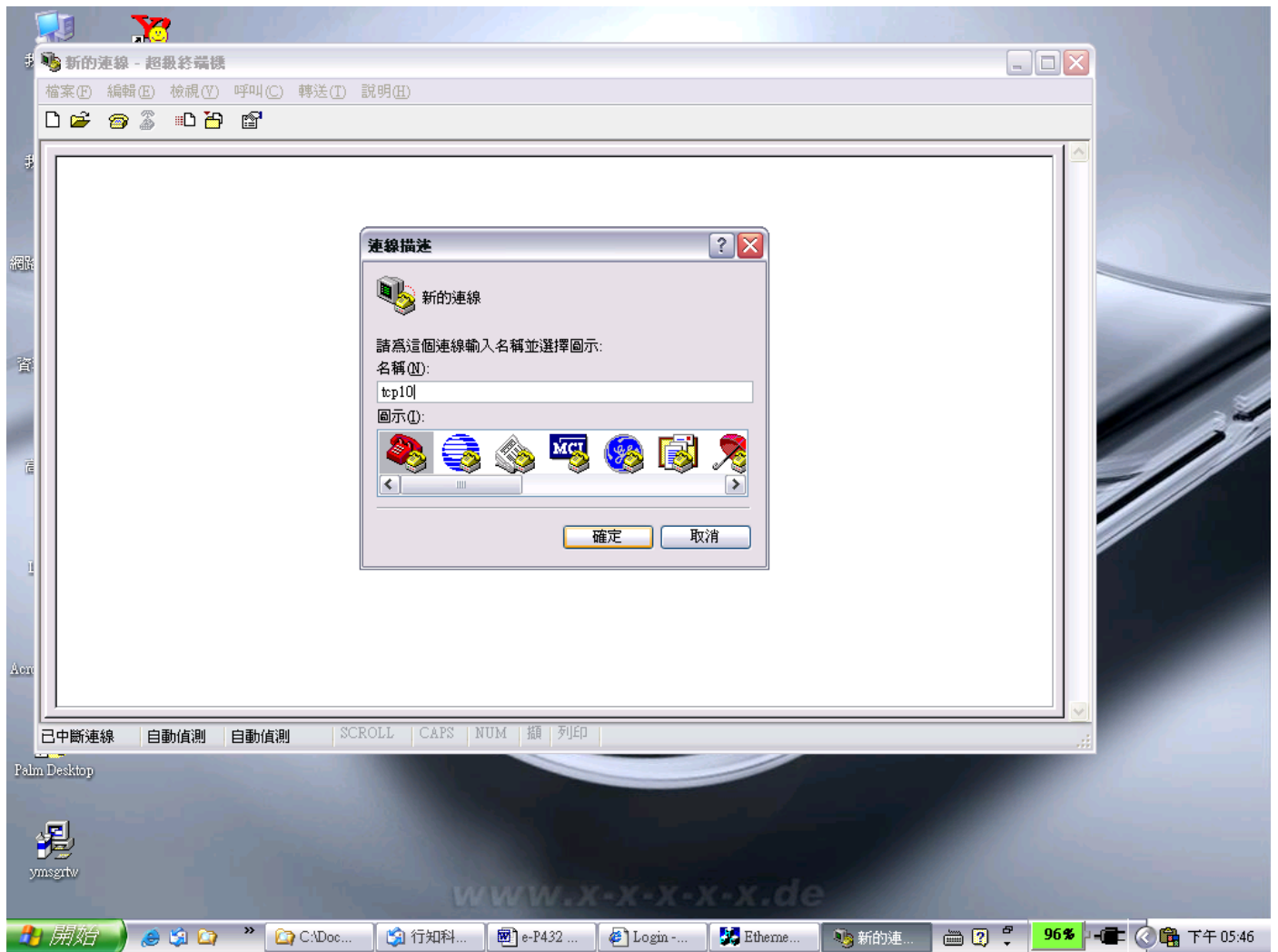

(Figure 6.2)

Select “TCP/IP(Winsock)” option at the “Connect using:” field (see Figure 6.3).

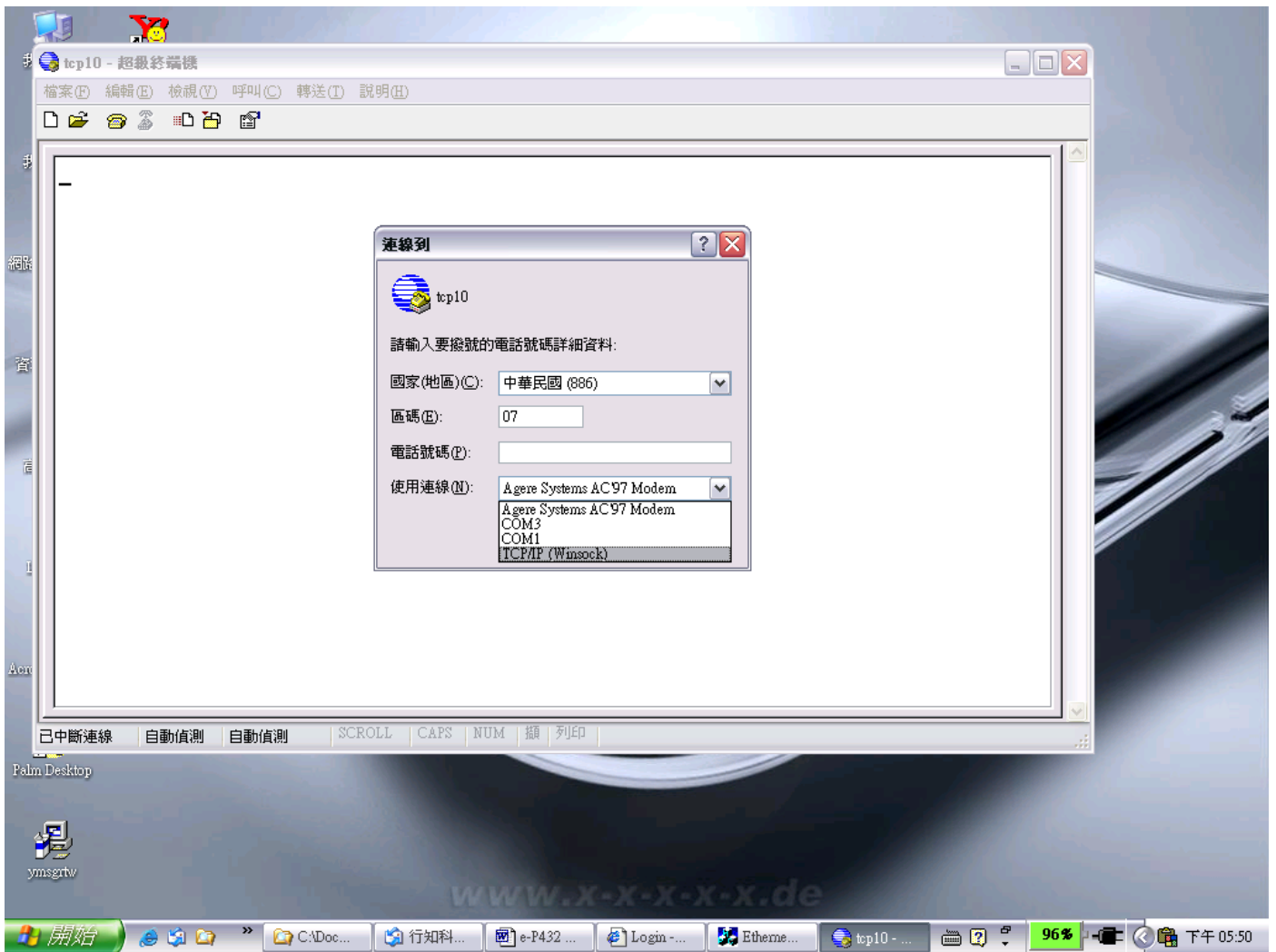

(Figure 6.3)

After “OK” button is pressed, Figure 6.4 appears. Enter the converter’s IP address (e.g. 192.168.123.10) at the “Host address:” field, and the Socket port number set for the Serial Port 1 at the “Port number:” field (e.g 4660). (The Socket type of the Serial Port 1 should be “TCP Server”.)

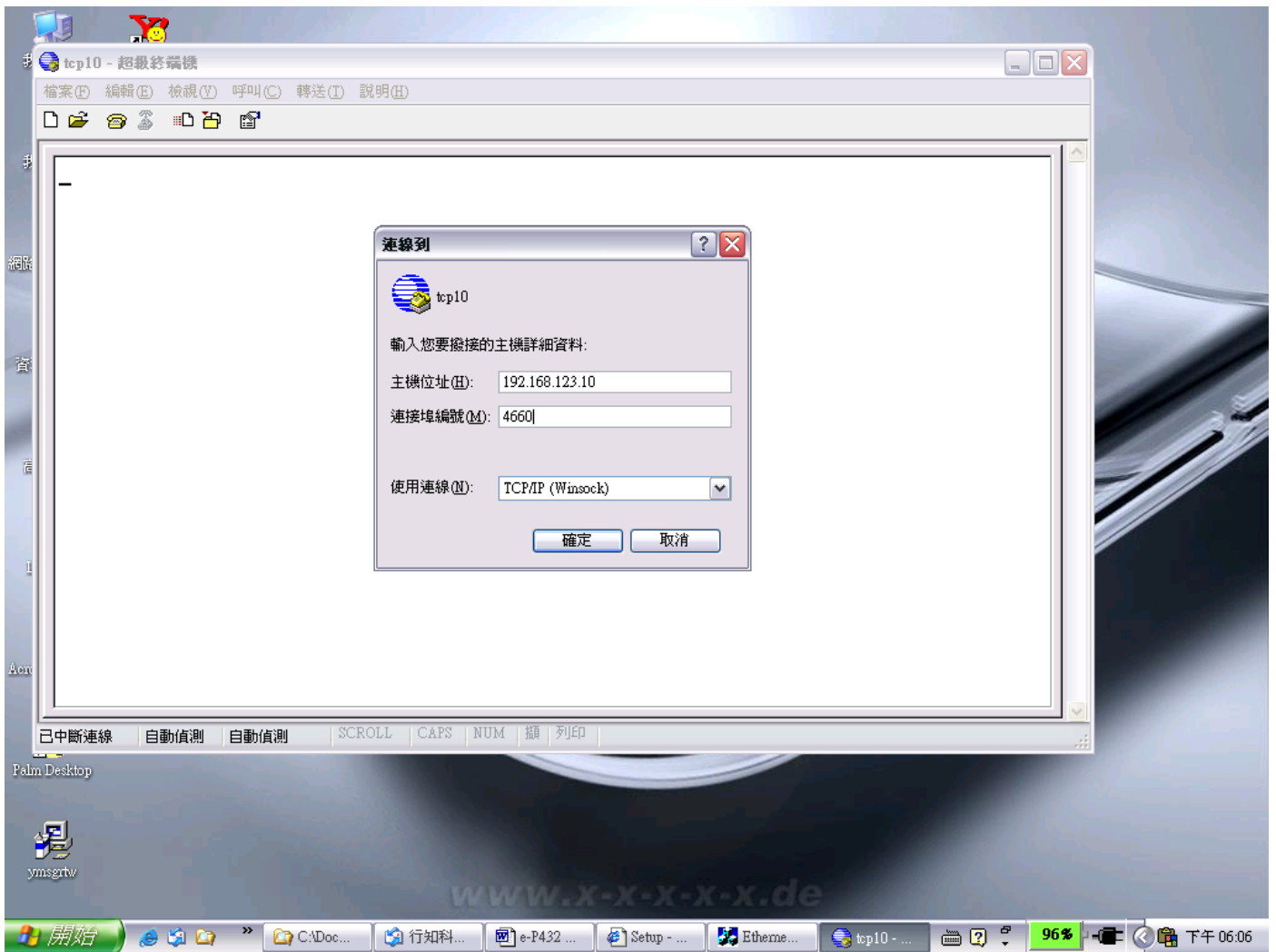

(Figure 6.4)

After “OK” button is pressed, Figure 6.5 appears. If the Hyper Terminal connects with the converter successfully, the time clock at the left lower corner “Connected hh:mm:ss” will start counting.

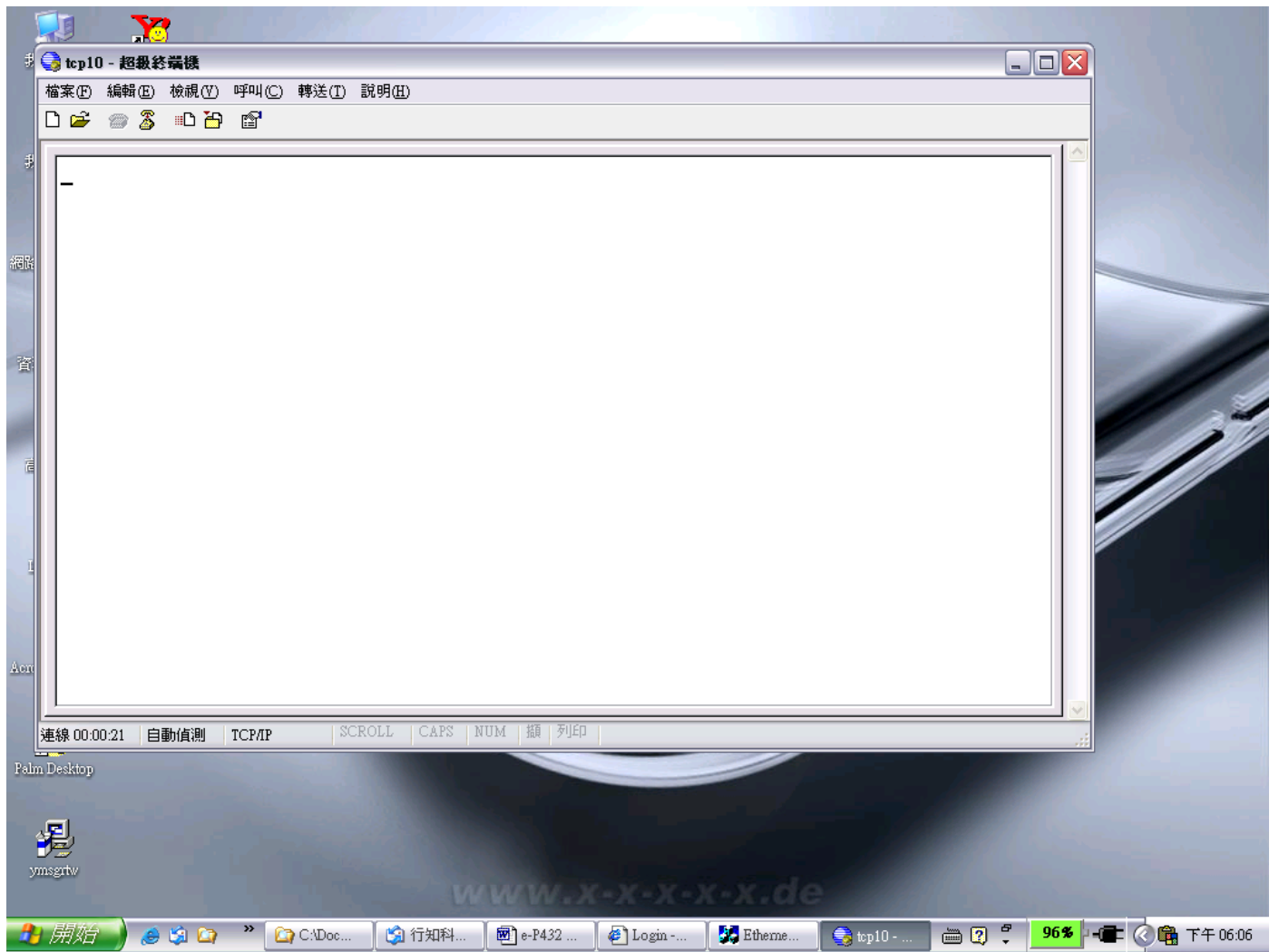

(Figure 6.5)

## Hyper Terminal for COM Port

Initiate another Hyper Terminal as a COM Port Terminal (in Figure 6.3, select COM 1 or other COM port instead of “TCP/IP (Winsock)”). Set the COM port Properties to be the same as those set for the Serial Port 1 of the converter.

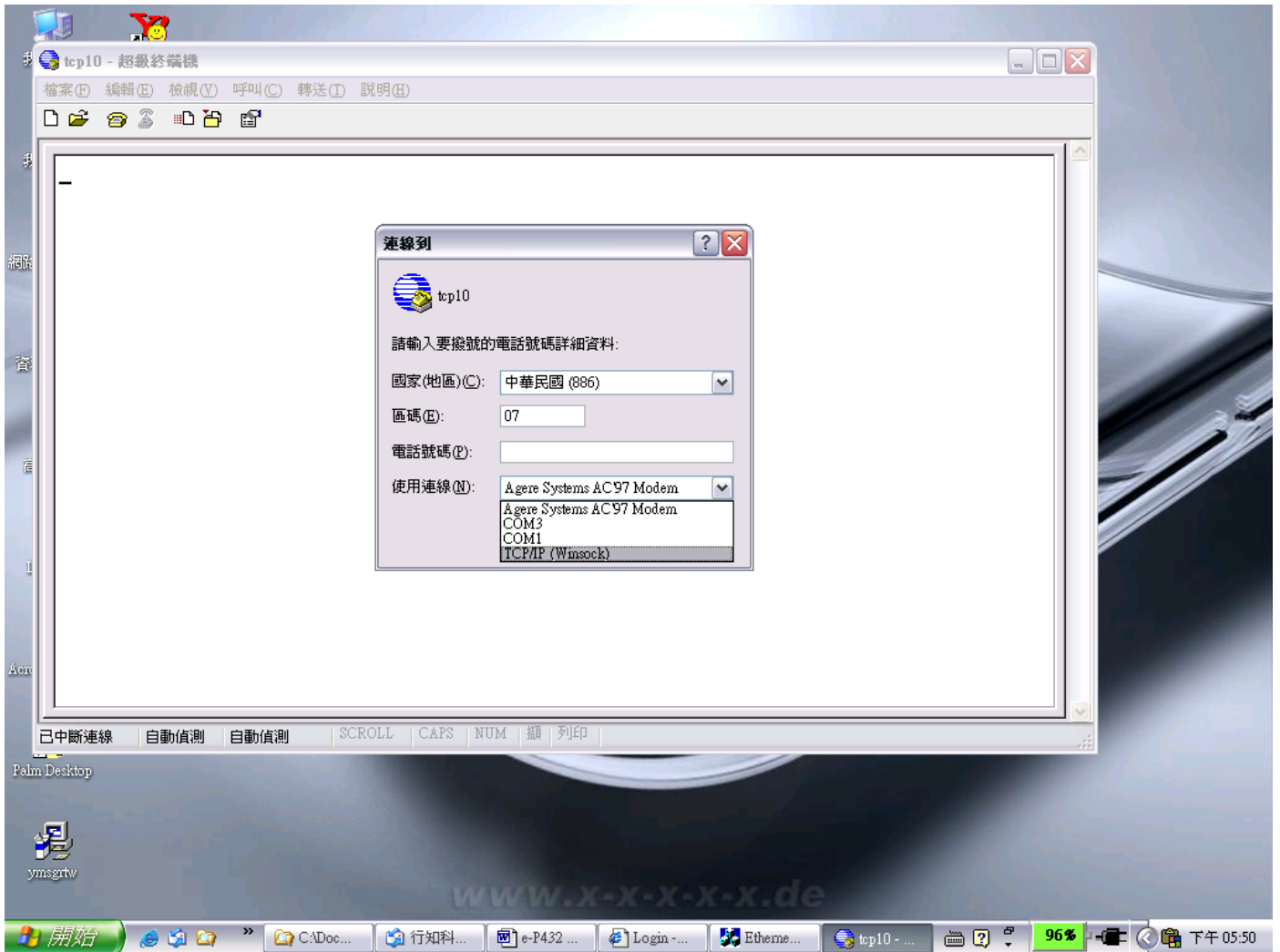

(Figure 6.3)



## **Data Transmission**

When all steps described above are finished, type any characters on the COM Port Terminal and check if the typed characters are also displayed on the TCP/IP Winsock Terminal. Alternatively, check if the characters typed on the TCP/IP Winsock Terminal are also displayed on the COM Port Terminal. If yes, then all settings are correct and the converter can operate properly.

# Appendix A

## FAQ

---

Q. Why can't the ETM.exe detect the converter on the network?

A. Please check

- ❑ if the power is properly plugged to the converter.
- ❑ if the network cable is properly connected between the converter and the Hub.

Refer to the "Hardware Installation" steps in Chapter 3.

Q. Why can't I use IE to setup the converter?

A. Please check if the network domain of your PC is the same as that of the converter.

# Appendix B

## Pin outs and Cable Wiring

### DC-In Jack

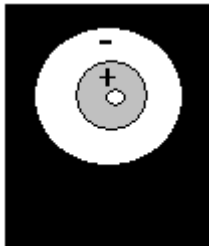

### RJ-45 Pin Assignment

e-P432介面示意圖

俯視面

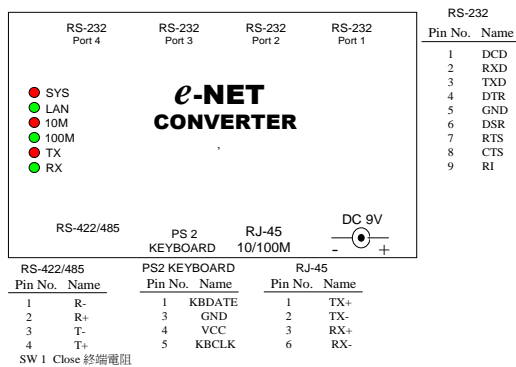

### RS-232 Pin Assignment

The pin assignment scheme for a 9-pin male connector on a DTE is given below.

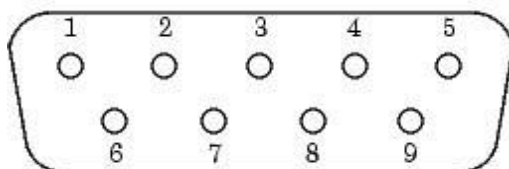

PIN 1 : N/A

PIN 2 : RXD

PIN 3 : TXD

PIN 4 : N/A

PIN 5 : GND

PIN 6 : N/A

PIN 7 : RTS

PIN 8 : CTS

PIN 9 : N/A

❑ **RS-232 Wiring Diagram**

Serial Device	e-NET Converter
2 RX	3 TX
3 TX	2 RX
5 GND	5 GND
7 RTS	8 CTS
8 CTS	7 RTS

❑ **RS-422 Pin Assignment**

The pin assignment scheme for a 4-pin RS-422 is given below.

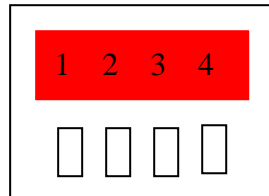

PIN 1 : R-      PIN 2 : R+      PIN 3 : T-      PIN 4 : T+

❑ **RS-422 Wiring Diagram**

Serial Device	e-NET Converter
R-	3 T-
R+	4 T+
T-	1 R-
T+	2 R+

❑ **RS-485 Wiring Diagram**

Serial Device	e-NET Converter
R- T-	1 R- 3 T-
R+ T+	2 R+ 4 T+

# Appendix C

## Troubleshooting Guide

---

# Appendix D

## Firmware Upgrade

---

As the firmware of the converter always keeps on enhancing with latest technologies and network standards, if your applications need the latest release of firmware, you will receive a Win32 executable utility and a ROM binary file to upgrade the converter firmware through network:

1. Set the target converter to have IP address in the same subnet as your host computer.
2. In the DOS Prompt environment of Windows, execute the upgrade utility eUpg32.exe, with the ROM file name you received as the first parameter and the target converter IP address as the optional second parameter. For example:

```
eUpg32 ROM. bin 10.0.0.123
```

If you omit the target IP address, the upgrade software will try to find one automatically.

3. The upgrade will start immediately with percent finished displayed on screen. Wait until 100% complete. Please note during upgrade, do not stop the software or remove the power of the converter, or it will cause permanent damage of firmware and can not be recovered.