



**GB** *Installation manual*

## Contents

<b>1. INTRODUCTION</b>	<b>2</b>
1.1 GENERAL	2
<b>2. SAFETY RULES</b>	<b>2</b>
2.1 GENERAL NOTES	2
2.2 SYMBOLS	2
2.3 DEFINITIONS OF "OPERATOR" AND "SPECIALISED TECHNICIAN"	3
2.4 PERSONAL PROTECTION DEVICES (PPD)	3
2.4.1 <i>Protection devices to wear</i>	3
2.5 GENERAL WARNINGS	4
2.6 EMERGENCIES	4
2.6.1 <i>First aid</i>	4
2.6.2 <i>Fire-fighting measures</i>	4
2.7 AIRBORNE NOISE EMISSION	5
2.8 OPERATOR WORKING POSITION	5
<b>3. UNPACKING AND POSITIONING</b>	<b>6</b>
3.1 VISUAL INSPECTION	6
3.1.1 <i>Checking the machine and equipment supplied</i>	6
3.2 UNPACKING	6
3.3 PACKING LIST	7
3.4 STORAGE	7
3.5 HANDLING	7
3.5.1 <i>Removing the pallet</i>	8
3.6 POSITIONING	8
3.6.1 <i>Warnings for positioning</i>	8
<b>4. INSTALLATION</b>	<b>9</b>
4.1 CLEANING	9
4.2 AMBIENT CHARACTERISTICS	9
4.3 FITTING THE ADAPTERS	9
4.4 ELECTRICAL CONNECTION	10
4.4.1 <i>Safety rules</i>	10
4.4.2 <i>Connection</i>	10
4.5 PNEUMATIC CONNECTION	10
<b>5. RESIDUAL RISKS</b>	<b>11</b>

# 1. Introduction

## 1.1 GENERAL

The machine has been constructed in conformity with the current EC Directives and the technical standards implementing the requirements, as stated in the declaration of conformity issued by the manufacturer and attached to the manual. This publication, hereinafter simply referred to as '**manual**', contains all the information for safe installation of the machine stated in the declaration of conformity.

This manual addresses operators previously instructed on the precautions to adopt when working in the presence of electrical power and moving devices as well as on manual load handling which imposes that loads handled manually may not exceed 30 kg for men and 20 kg for women. Should the weight of the wheels to be balanced exceed the permitted limits, all our balancing machines can be supplied with a lift to facilitate tyre mounting/dismounting, as an option or standard based on the model. The manual addresses operators instructed on the precautions to take in relation to the presence of electric current and moving devices. This publication is intended for all 'users' who as far as within their competence need to and/or are obliged to give instructions to others or operate on the machine themselves.

The original Italian text of this publication constitutes the only reference to resolve any interpretation controversies related to the translation into the European Community languages.

This publication forms an integral part of the machine and must therefore be kept for future reference until final dismantling and scrapping of the machine. For installation, startup and use of the machine, the user must comply with the specific workplace legislation in force in the country where the machine is installed.

# 2. Safety rules

## 2.1 GENERAL NOTES



### WARNING

BEFORE PERFORMING ANY OPERATION ON THE MACHINE, CAREFULLY READ THROUGH THE ENTIRE MANUAL,  
PAYING PARTICULAR ATTENTION TO THIS CHAPTER.

The machine has been designed and constructed in observance of the CE requirements taking into account normal and reasonably foreseeable use.

The machine has been constructed for the application stated in the user manual attached hereto.

It is not permitted for any reason whatsoever to use the machine for purposes different from those for which it was designed nor to use it in ways different from those described in this manual.

The various operations must be performed according to the criterion and the chronology described in this manual.

## 2.2 SYMBOLS

Throughout this manual dangerous operations are highlighted with graphic symbols to draw the reader's attention.

*The following graphic symbols are used:*



### WARNING

THIS WARNING INDICATES POSSIBLE OCCURRENCE OF AN EVENT THAT MAY LEAD TO SERIOUS INJURY OR EXTENSIVE DAMAGE  
TO THE MACHINE IF ADEQUATE PRECAUTIONARY COUNTERMEASURES ARE NOT TAKEN.

---

---

**INFORMATION**

*This warning indicates important information which must be carefully read.*

---

### 2.3 DEFINITIONS OF “OPERATOR” AND “SPECIALISED TECHNICIAN”

Any professional person who is to access the machine for operation and routine maintenance is defined as an “operator”. This means persons who have knowledge of the operating and maintenance procedures of the machine and have the following qualifications:

1. training that authorises operation according to the safety standards in relation to the risks deriving from the presence of electrical power and moving devices and the risks related to manual load handling.
2. Trained to use the personal protection devices and basic first aid training.

The employer must assign a suitable person to operate the machine in accordance with the laws in force, assessing his or her psycho-physical health, personal education, training and experience, as well as knowledge of the standards, requirements and provisions for accident prevention.

In addition, the operator assigned based on the above must be specifically trained for use of the machine and any accessories.

Finally, the operator must read through this manual.

### 2.4 PERSONAL PROTECTION DEVICES (PPD)



**WARNING**

**DURING MACHINE INSTALLATION AND USE IT IS STRICTLY PROHIBITED TO OPERATE WITHOUT THE PROTECTION DEVICES DESCRIBED IN THIS PARAGRAPH.**

---

The persons that are to operate on and/or work in proximity of the machine may not wear clothes with wide sleeves, laces, belts, bracelets or anything else that may pose a potential risk. Long hair must be tied up to prevent any risk.

#### 2.4.1 Protection devices to wear

The following protection devices must be worn.



**Insulated safety shoes with rubber sole and reinforced tip**  
Use: always  
(EN345)



**Protective gloves**  
Use: always  
(EN388)



**Goggles**  
Use: always  
(EN166 1F)



**Working clothes**  
Use: always  
(EN510)

## 2.5 GENERAL WARNINGS



### CAUTION:

THE MACHINE GENERATES, USES AND MAY IRRADIATE ENERGY AND RADIO FREQUENCY. IF NOT INSTALLED AND USED IN ACCORDANCE WITH THE INSTRUCTIONS IN THIS MANUAL, IT MAY CAUSE INTERFERENCE WITH RADIO COMMUNICATIONS.

- The machine must be installed, maintained and used according to the instructions given in this manual and according to the procedures given from case to case.
- The employer must train the operators for safe installation, use and maintenance of the machine.
- Only specialised and specifically trained persons are to be allowed access to the machine for any extraordinary maintenance operation.
- Before operating on the electrical parts of the machine cut the power.
- For the duration of maintenance, “**Work in progress**” signs must be posted in the department in such a way that they are visible from all the access areas.
- Always operate with due caution and wear the personal protection devices (PPD).
- The machine (and any accessory devices) must always be connected to earth to discharge short-circuit currents and electrostatic voltages. The mains voltage must correspond to the value shown on the machine identification plate. It is inadvisable to use cable extensions/socket adaptors. When the machine is not used, disconnect it from the mains by pulling the plug from the socket.
- Before carrying out any operation stop the machine.
- In the event of fire, do not use water but only powder or carbon dioxide fire extinguishers.
- It is strictly prohibited to deposit combustible material in the vicinity of the machine.
- Do not deactivate the safety devices or ignore warnings and alarms, be they communicated by the software or by warning labels fixed on the installation. Should the plates, adhesive labels, decals or any other warning sign on the machine deteriorate they must be replaced.
- It is not permitted for any reason whatsoever to modify, tamper with or alter the machine structure, the devices fitted, the operating sequence, etc. without prior consultation with the manufacturer.
- All the routine and extraordinary maintenance operations must be recorded in the logbook noting down the date, time, type of operation, name of the operator and any other useful information.
- In the event of faults or malfunctioning, contact your local distributor or the manufacturer. All the repair operations must be performed by qualified technicians.
- It is strictly prohibited to clean the internal and external electrical parts of the wheel balancer with water.
- Exclusively use alcohol to clean the machine. Do not use any other chemical product. Do not under any circumstances blast with compressed air.
- Do not leave the machine exposed to the rain or the elements. The ambient storage and operating conditions must meet the requirements set out in the chapter INSTALLATION.
- In the event of failure, deformation or malfunctioning of the safety devices, immediately replace them; “Makeshift” repairs are strictly prohibited. Use only original spare parts for which the machine has been designed and constructed.
- The machine and the workplace must be kept perfectly clean.
- When the maintenance operations have been completed, before restoring the power supply, carefully check that you have not forgotten tools and/or other materials in the machine operating area. In any event, also during operation, no object may be placed on the protection shield.

## 2.6 EMERGENCIES

### 2.6.1 First aid

For any first aid follow the corporate regulations and conventional procedures.

### 2.6.2 Fire-fighting measures

Do not use water to extinguish fires, but only powder or carbon dioxide extinguishers. Preferably use extinguishers filled with a special powder for metal fires.

## **2.7 AIRBORNE NOISE EMISSION**

The machine noise, measured with the machine empty, is constantly contained at levels below 70 dB(A).

During operation the machine noise is subordinate to the background noise in the workplace, the presence of other machines and other factors that cannot be assessed by the manufacturer in advance.

The user therefore needs to make a phonometric measurement of the noise emitted by the machine during normal operation, and provide for personal protection devices (headsets) if the noise emission exceeds the threshold laid down in the regulations in force in the country where the machine is used.

## **2.8 OPERATOR WORKING POSITION**

During balancing the operator must stand in front of the control console and avoid standing in front of the wheel during the balancing cycle.

## 3. Unpacking and positioning

### 3.1 VISUAL INSPECTION

The packaging must be intact upon receipt, i.e.:

- There must not be any sign of collision or breakage
- There must not be any sign that it was exposed to sources of heat, ice, water, etc.
- There must not be any sign of tampering.

Any deformations indicate that the machine was knocked about during transport and may compromise proper machine functioning.

#### 3.1.1 Checking the machine and equipment supplied

The main body of the machine, the relative accessories and the equipment supplied (as agreed with the manufacturer) must be in perfect condition.

The supply is carefully checked before shipment, nevertheless it is advisable to check upon receipt that it is complete and in order.

#### **Check that:**

- The shipping data (addressee, number of packages, order number, etc.) correspond to the accompanying documentation.
- The technical-legal documentation provided with the machine includes the instruction manual for the type of machine to be installed as well as the EC declaration of conformity or, alternatively, the declaration of the manufacturer.

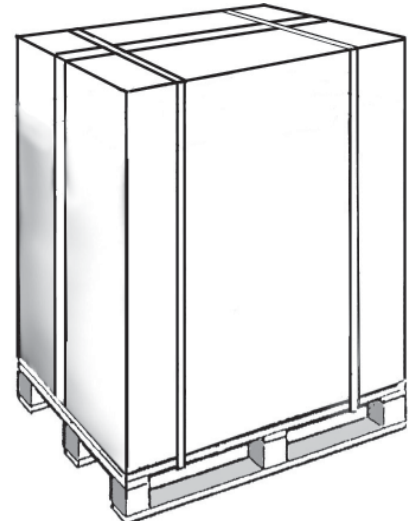

#### **INFORMATION**

*In the event of defects and/or missing material immediately notify the manufacturer and follow his instructions before proceeding with installation and startup.*

### 3.2 UNPACKING

To remove the packaging refer to the "arrow" shown on the outside box.

*Operate as follows to unpack the machine:*

1. Cut the plastic safety straps
2. Open the top of the cardboard box
3. Remove the top protection
4. Remove any protective corner pieces
5. Remove the cardboard box pulling it upward
6. Remove any protective "pluriball"
7. Inspect the machine to check for any damage. Immediately inform the carrier and the supplier in the event of apparent damage.

**Keep the packaging materials for possible future shipment of the machine.**

#### **INFORMATION**

*The packaging used is in compliance with the environmental requirements set out in the European packaging regulations (Official EC Gazette, N. L. 365/19). The cardboard boxes can easily be recycled. The plastic wrappings are made of materials free of hazardous metals. It is advisable to contact the competent local authority for their disposal.*

### 3.3 PACKING LIST

All the materials included in the supply are listed on the packing list. The contents may vary from machine to machine depending on the sales agreements, the optional parts supplied, etc.

Generally, the supply includes:

- the machine
- the toolbox
- the instruction manual

### 3.4 STORAGE

When the machine:

- is not immediately installed;
- is uninstalled and stored pending moving to another place

position it in a covered place protected against direct contact with atmospheric agents and dust. The permitted ambient values in the storage area are as follows:

- *Temperature: +5 to +40°C (41 - 104°F)*
- *Relative humidity: 30÷80 %.*

If taking the machine out of service after a period of use and after performing the necessary maintenance operations, it can be stored for a period of **not more than two years**, provided that it is stored in a closed dust-free environment without aggressive agents and with the following characteristics:

- Ambient conditions as described above
- Positioned in such a way that it is protected against deformation, crushing, breakage, etc.
- Not subjected to knocks, vibrations, overhanging loads, etc.

### 3.5 HANDLING

The term “handling” means unloading the machine from the means of transport and positioning it in the place where it will be used. Upon receipt the customer needs to unload the machine using his own means and store it in a dry and protected place pending installation.

The machine is to be handled while still fastened on the wooden pallet (see next paragraph) by suitably trained persons wearing the personal protection devices described in Chapter 2.



#### WARNING

**HANDLE THE MACHINE WITH EXTREME CARE, LIFTING IT THE MINIMUM NECESSARY AND AVOIDING DANGEROUS OSCILLATION AND UNBALANCING. BEFORE MOVING THE MACHINE, IT MUST BE TIED TO THE LIFT TRUCK (OR TRANSPALLET) TO PREVENT IT FROM SHIFTING AND TURNING OVER.**

---

Before lifting the machine with a lift truck or transpallet, make sure that the forks are properly positioned and protrude from the opposite side by at least 30 cm.

### 3.5.1 Removing the pallet

The machine is secured to a base pallet. Prepare an adequate area with level flooring and mark it off before lifting the machine and positioning it on the ground.

To remove the machine from the pallet operate as follows:

- Remove the screws that lock the machine to the pallet (figure on the side)

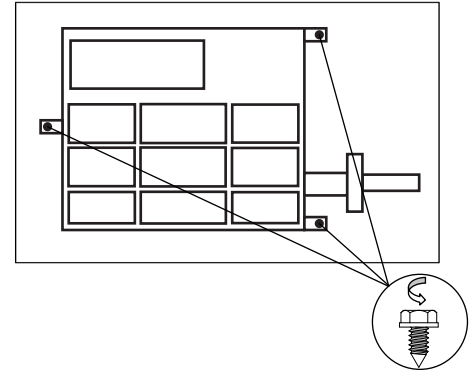

#### WARNING

MANUAL HANDLING AND LIFTING OF THE MACHINE MUST BE CARRIED OUT WITH THE AID OF A LIFT TRUCK. PRISE ON THE BASE NEAR THE 3 SUPPORT POINTS AS SHOWN IN THE FIGURE BELOW. OTHER POINTS, SUCH AS THE HEAD OR THE ACCESSORY TRAY, MUST NOT BE FORCED UNDER ANY CIRCUMSTANCES.

## 3.6 POSITIONING

### 3.6.1 Warnings for positioning

The machine must be positioned respecting the following conditions:

- The humidity and the temperature must be within the prescribed limits (see paragraph 4.2).
- The fire-fighting measures must be respected
- Allow for sufficient space at the front, side and rear of the machine for service or periodic maintenance and at the same time to assure adequate air circulation. It is advisable to leave a space of about 1 metre around the machine.
- The place where the machine is installed must be free of corrosive/explosive powders or gas.
- The place of installation must be vibration-free.
- The lighting must be such that the various machine functions can clearly be seen.
- Lift the machine and position it correctly in its final position (figure on the side)
- The machine must stand on a flat rigid surface and possibly away from any joint in the floor.

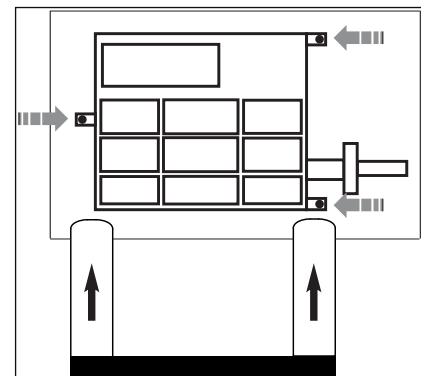

#### INFORMATION

According to UNI EN 10380 regulations, the lighting for a generic working area (such as control rooms, fixed workstations in production plants, etc.) must on average be 300 lux (acceptable values between 200 and 500 lux). If the machine is installed in a country different from Italy, the specific regulations in that country must be followed.

The lighting system must be such as to guarantee average lighting of 300 lux for the working environment. This value depends on various factors, such as the characteristics of the working environment (more or less reflecting walls and ceiling, height of the light points, etc.) and the type of bulbs used.



## 4. Installation



### WARNING

THE INSTRUCTIONS IN THIS CHAPTER ADDRESS THE OPERATOR WHO MUST OPERATE WEARING THE PERSONAL PROTECTION DEVICES INDICATED IN CHAPTER 2.

### 4.1 CLEANING

Before starting the machine, clean off any dust, foreign matter and soiling that may have accumulated during transport. Use alcohol to clean the plastic parts.



### CAUTION:

DO NOT USE LIQUIDS CONTAINING SOLVENTS OR BLASTS OF COMPRESSED AIR TO CLEAN THE WHEEL BALANCER.

### 4.2 AMBIENT CHARACTERISTICS

The operating environment must have the following characteristics:

- *Temperature: + 5 to + 40°C (41 - 104°F)*
- *Maximum relative humidity: 80%*

The machine may not be used in open places and/or exposed to atmospheric agents or in environments with corrosive and/or abrasive vapours, fumes or dust with the risk of fire or explosion, and in any case where the use of explosion-proof components is prescribed.



### CAUTION:

SHOULD AT THE TIME OF INSTALLATION THE AMBIENT CONDITIONS BE DIFFERENT FROM THOSE PRESCRIBED, OR IF THEY HAVE CHANGED OVER TIME, DO NOT USE THE MACHINE BUT IMMEDIATELY CONTACT THE MANUFACTURER FOR THE RELATIVE INSPECTION.

### 4.3 FITTING THE ADAPTERS

#### INFORMATION

*Before fitting the terminal to the wheel balancer, thoroughly clean the machine shaft and the adapter hole. Any traces of dirt or incorrect locking may affect balancing accuracy.*

The wheel balancer is supplied complete with adapter and cones for fastening wheels with a central hole. The threaded terminal must be fitted during machine installation using the Allen wrench provided applying the correct tightening torque (20-25Nm). If it is a machine with pneumatic locking, follow the procedure indicated in the use and maintenance manual. In both cases, it can be removed for fitting any optional adapters.

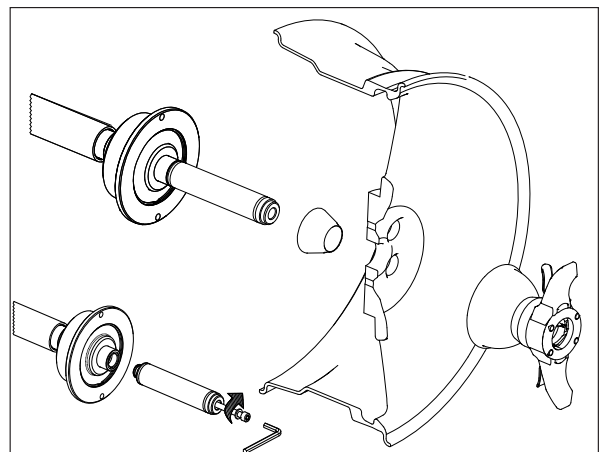

**CAUTION:**

USING NON-ORIGINAL ACCESSORIES MIGHT COMPROMISE THE MEASURING QUALITY. CONTACT THE MANUFACTURER FOR THE SUPPLY OF SPECIAL ADAPTERS OR SPARE PARTS OF ANY KIND.

## 4.4 ELECTRICAL CONNECTION

### 4.4.1 Safety rules

Before performing any operation, read and apply the following:

- Make sure that the main electric cabinet to which the machine is connected is connected to the earth circuit and is adequately protected as required by the regulations in force in the country where the machine is installed. The socket to which the machine is connected must have a slow acting safety switch calibrated to 4 A (230V) or 8A (115V).
- Check that the mains voltage and frequency correspond to the values indicated on the machine identification plate.
- The socket to which the machine is connected must be dimensioned to support the power absorbed up to a maximum of 1.1 kW.

### 4.4.2 Connection

The machine is supplied with a single-phase cable to which a plug conform to the regulations must be connected. If an extension needs to be used, bear in mind that the wire cross-section may not be less than 2.5 mm<sup>2</sup>. Make sure that the extension is arranged so that it does not constitute a risk or obstruction.

**WARNING**

THE CONNECTION TO THE SINGLE-PHASE MAINS MUST ALWAYS BE MADE BETWEEN PHASE AND NEUTRAL AND NEVER BETWEEN PHASE AND EARTH!

**IT IS STRICTLY PROHIBITED TO TURN ON THE MACHINE IF IT IS NOT PROPERLY CONNECTED TO EARTH ACCORDING TO THE TECHNICAL SPECIFICATIONS SET OUT IN THE REGULATIONS IN FORCE. IN ANY EVENT, THE ELECTRICAL CONNECTIONS MUST BE CARRIED OUT EXCLUSIVELY BY A SPECIALISED TECHNICIAN.**

## 4.5 PNEUMATIC CONNECTION

If the machine is equipped with a pneumatic locking/release spindle and/or zero weight lift, it needs to be fed with compressed air at 8-10 bar. The compressed air coupling is positioned on the rear of the machine. The compressed air must be clean and dry. The pipes and pipe fittings must be properly connected by appropriately trained personnel. The warranty does not cover damage caused by the absence of an adequate air filtration system.

## 5. Residual risks

Residual risk means a potential risk impossible to eliminate or partially eliminatable, which may cause injury to the operator if operating using improper working methods and practices.

- Pay attention to the position of your hands in the areas indicated in the figure, as there is a risk of crushing your fingers during wheel locking on the spindle.
- While mounting or dismounting the tyre, pay attention to avoid accidentally crushing your feet.
- For machines equipped with lift, do not stand in the working area, as there is a risk of crushing during ascent and descent of the lift.

