

Classic Series
Cabinets



Frame your fireplace
with a look all your own.

Hearth Cabinets



The perfect compliment to the perfect fireplace.

Nothing completes the hearth like a finely crafted wooden cabinet. Unlike a traditional mantel, a hearth cabinet doesn't require marble, tile or other surround facing. It's easy to install and can suit almost any décor. So choose your style, choose your finish, and make your fireplace something special.



Cherry



Cool White



Medium Oak

Premium Wall Cabinet Specs

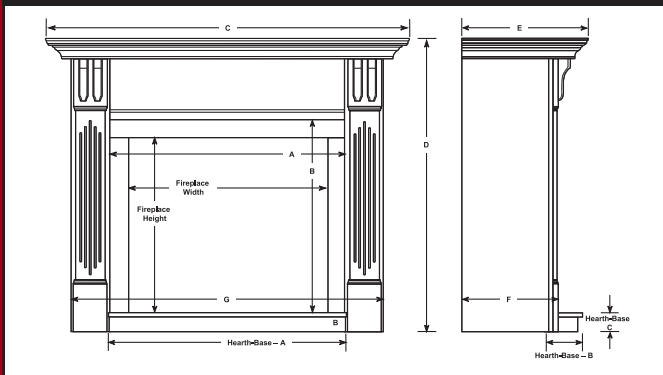

PREMIUM Flat/Corner Wall Cabinets for 33" and 36" Fireplaces

The Premium Series wooden wall cabinet mantel's natural beauty will complement any style of room. The carved details in the legs and arched mantel supports can give a space personality and function. Offered in Cool White paint finish, Medium Oak stain and Premium Cherry stain finish.

Premium Corner Cabinet Specs

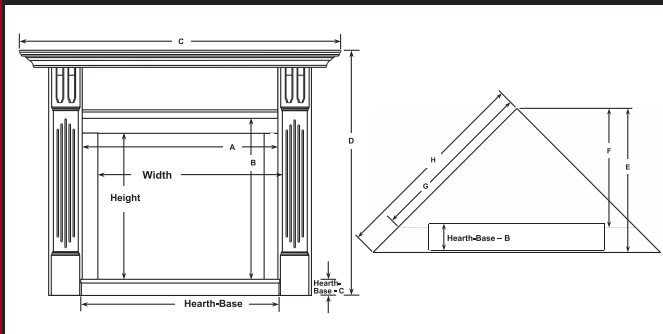

The Premium cabinet is suitable for a multitude of Direct Vent gas, Vent-free gas and Electric Fireplaces - for flat wall and corner applications.

Wall 33" Fits:	33XDV (Top & Rear Vent), VCEF33
Corner 33" Fits:	33LDV (Top & Rear Vent), 33XDV (Top & Rear) VCEF33
Wall 36" Fits:	36LDV (Top & Rear Vent), 36XDV (Top & Rear), VCEF36
Corner 36" Fits:	36LDV (Top & Rear Vent), VCEF36

Model	Description	Dimensions								Hearth		
		A	B	C	D	E	F	G	H	A	B	C
PRWPC33	Premium 33" Wall Cabinet Premium Cherry	39"	32"	60 1/4"	48 5/8"	21"	16 1/8"	51 3/4"		39"	6 1/4"	3 1/4"
PRWMO33	Premium 33" Wall Cabinet Medium Oak	39"	32"	60 1/4"	48 5/8"	21"	16 1/8"	51 3/4"		39"	6 1/4"	3 1/4"
PRWCW33	Premium 33" Wall Cabinet Cool White	39"	32"	60 1/4"	48 5/8"	21"	16 1/8"	51 3/4"		39"	6 1/4"	3 1/4"
PRWPC36	Premium 36" Wall Cabinet Premium Cherry	42"	37 1/4"	63 1/4"	53 7/8"	23"	18 1/8"	54 3/4"		42"	6 1/4"	3 1/4"
PRWMO36	Premium 36" Wall Cabinet Medium Oak	42"	37 1/4"	63 1/4"	53 7/8"	23"	18 1/8"	54 3/4"		42"	6 1/4"	3 1/4"
PRWCW36	Premium 36" Wall Cabinet Cool White	42"	37 1/4"	63 1/4"	53 7/8"	23"	18 1/8"	54 3/4"		42"	6 1/4"	3 1/4"
PRCPC33	Premium 33" Corner Cabinet Premium Cherry	39"	32"	63 3/4"	48 5/8"	31 7/8"	26 1/8"	37"	45 1/8"	39"	6 1/4"	3 1/4"
PRCMO33	Premium 33" Corner Cabinet Medium	39"	32"	63 3/4"	48 5/8"	31 7/8"	26 1/8"	37"	45 1/8"	39"	6 1/4"	3 1/4"
PRCCW33	Premium 33" Corner Cabinet Cool White	39"	32"	63 3/4"	48 5/8"	31 7/8"	26 1/8"	37"	45 1/8"	39"	6 1/4"	3 1/4"
PRCPC36	Premium 36" Corner Cabinet Premium Cherry	42"	37 1/4"	69 1/2"	53 7/8"	34 3/4"	29"	41"	49 1/8"	42"	6 1/4"	3 1/4"
PRCMO36	Premium 36" Corner Cabinet Medium Oak	42"	37 1/4"	69 1/2"	53 7/8"	34 3/4"	29"	41"	49 1/8"	42"	6 1/4"	3 1/4"
PRCCW36	Premium 36" Corner Cabinet Cool White	42"	37 1/4"	69 1/2"	53 7/8"	34 3/4"	29"	41"	49 1/8"	42"	6 1/4"	3 1/4"



Forester Cabinet and
Hearth Base in Honey Oak



Forester Corner Cabinet and Hearth
Base, shown here painted white

FORESTER Cabinet

The "Forester" is a Classic Series cabinet including a three inch hearth base and is available for both flat wall and corner applications. This easy to assemble cabinet is offered in Honey Oak, Unfinished Oak, and a primed, ready for paint finish, allowing the homeowner to personalize the cabinet to any décor. The Forester is suited for selected Direct Vent, Vent Free and Electric Fireplaces and includes all hardware necessary for assembly.

The Forester cabinets are available for these Fireplaces:

Wall / Corner 33" Fits: 33LDV (Rear Vent), 33XDV (Rear Vent), VCEF33
Wall / Corner 36" Fits: 36LDV (Top & Rear Vent), 36XDV (Rear Vent)
Dedicated Wall Cabinets Fit: UV36, DVBR36, DV360

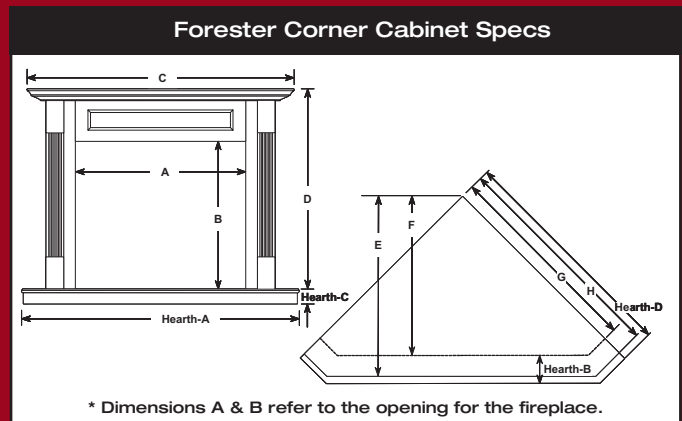
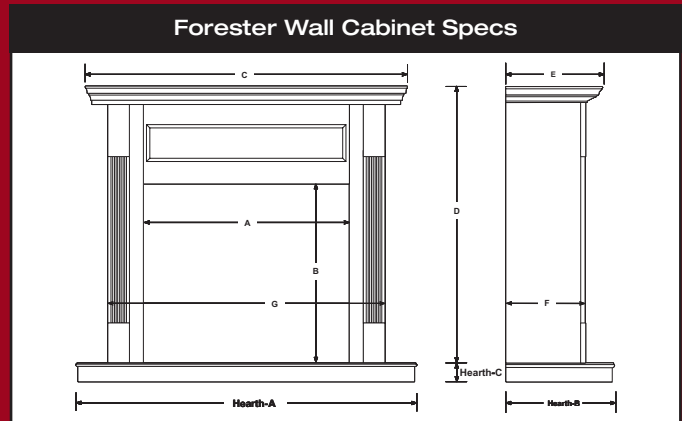

* Dimensions A & B refer to the opening for the fireplace.
 ** Note: When installing direct vent gas units, perimeter trim is required, check with your dealer.

Model	Description	A	B	C	D	E	F	G	H	Hearth			
										A	B	C	D
FOW033	Forester Wall Cabinet - Unfinished	33 1/2"	29 1/8"	52 1/2"	45 1/8"	18 7/8"	15 1/2"	45 1/4"		54 5/8"	20 1/4"	3"	
FOWH33	Forester Wall Cabinet - Honey Oak	33 1/2"	29 1/8"	52 1/2"	45 1/8"	18 7/8"	15 1/2"	45 1/4"		54 5/8"	20 1/4"	3"	
FOWW33	Forester Wall Cabinet - Primed	33 1/2"	29 1/8"	52 1/2"	45 1/8"	18 7/8"	15 1/2"	45 1/4"		54 5/8"	20 1/4"	3"	
FOW036	Forester Wall Cabinet - Unfinished	36 1/2"	34 1/2"	55 1/2"	50 1/2"	20 3/8"	17 1/2"	48 1/4"		57 5/8"	22 1/4"	3"	
FOWH36	Forester Wall Cabinet - Honey Oak	36 1/2"	34 1/2"	55 1/2"	50 1/2"	20 3/8"	17 1/2"	48 1/4"		57 5/8"	22 1/4"	3"	
FOWW36	Forester Wall Cabinet - Primed	36 1/2"	34 1/2"	55 1/2"	50 1/2"	20 3/8"	17 1/2"	48 1/4"		57 5/8"	22 1/4"	3"	
FOWU036	Forester Wall Cabinet - Unfinished/Fits: DVBR36, BREF36	40 1/2"	36 1/4"	59 1/2"	52 1/4"	25 3/8"	22 1/2"	52 1/4"		61 5/8"	27 1/4"	3"	
FOW0360	Forester Wall Cabinet - Unfinished/Fits: DV360	41 1/2"	37 3/4"	60 1/2"	53 3/4"	24 3/8"	21 1/2"	53 1/4"		62 5/8"	26 1/4"	3"	
F0C033	Forester Corner Cabinet - Unfinished	33 1/2"	29 1/8"	59 1/8"	45 1/8"	35"	31 1/4"	38 1/4"	41 7/8"	61 3/8"	5 1/2"	3"	42 3/4"
F0CH33	Forester Corner Cabinet - Honey Oak	33 1/2"	29 1/8"	59 1/8"	45 1/8"	35"	31 1/4"	38 1/4"	41 7/8"	61 3/8"	5 1/2"	3"	42 3/4"
F0CW33	Forester Corner Cabinet - Primed	33 1/2"	29 1/8"	59 1/8"	45 1/8"	35"	31 1/4"	38 1/4"	41 7/8"	61 3/8"	5 1/2"	3"	42 3/4"
F0C036	Forester Corner Cabinet - Unfinished	36 1/2"	34 1/2"	62 1/8"	50 1/2"	36 1/2"	32 3/4"	40 3/8"	44"	64 3/8"	5 1/2"	3"	44 7/8"
F0CH36	Forester Corner Cabinet - Honey Oak	36 1/2"	34 1/2"	62 1/8"	50 1/2"	36 1/2"	32 3/4"	40 3/8"	44"	64 3/8"	5 1/2"	3"	44 7/8"
F0CW36	Forester Corner Cabinet - Primed	36 1/2"	34 1/2"	62 1/8"	50 1/2"	36 1/2"	32 3/4"	40 3/8"	44"	64 3/8"	5 1/2"	3"	44 7/8"

Classic Series Cabinets

Models • Premium • Forester • Cortland



CORTLAND Cabinet

A wonderful cabinet that can suit both traditional and modern décor.

Available for both flat and corner applications – in three stain finishes:

- Pecan – a rich orangey-brown color
- New Age Oak – a fresh rendition of the classic medium oak color
- Espresso – an intense dark coffee tone

The Cortland cabinets are available for these Fireplaces:

Wall 33" Fits:	VCEF33
Corner 33" Fits:	VCEF33, 33LDVRRN, 33LDVRRP, 33LDVREN, 33XDVRN and 33XDVEN



Cortland Wall Cabinet
in Espresso Stain



Cortland Wall Cabinet
in Pecan Stain



Cortland Corner Cabinet
in New Age Oak Stain

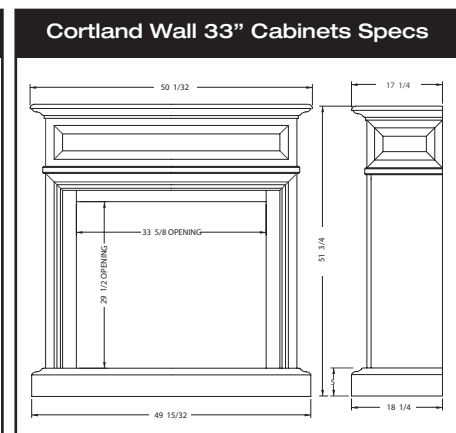
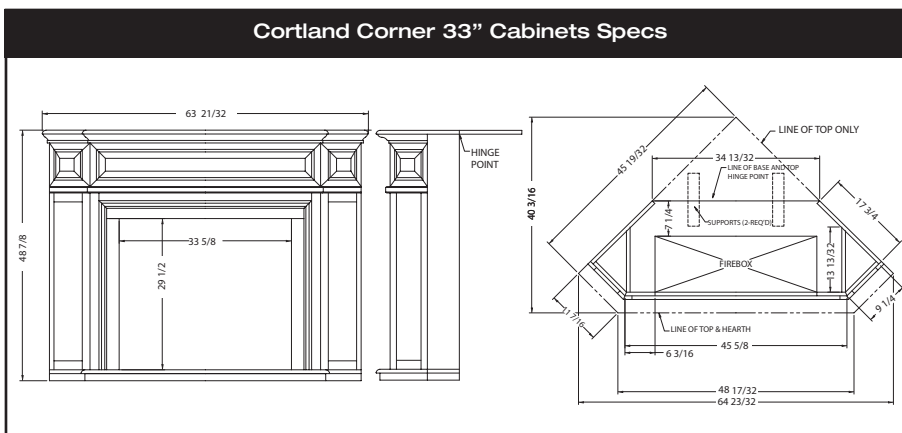

* Note: When installing Cortland with a direct vent gas fireplace, a perimeter kit is required.



ph: 1.800.525.1898

www.vermontcastings.com
www.majesticproducts.com

YOUR DEALER