

**USER'S MANUAL**

This manual is to be used with the GEMINI Robot System Version 1.0. ARCTEC SYSTEMS, INC. reserves the right to make improvements to the products described herein at any time and without prior notice.

#### DISCLAIMER

Although we have done our best to ensure the accuracy of this manual, ARCTEC SYSTEMS, INC. makes no warranties as to this manual or the software described herein, the quality, performance or suitability for any particular purpose.

This manual is COPYRIGHTED. All rights are reserved. It may not be reproduced in whole or in part by any means without prior written consent from ARCTEC SYSTEMS, INC.

The ARCTEC SYSTEMS logo and GEMINI, the word and logo, are trademarks of ARCTEC SYSTEMS, INC.

## TABLE OF CONTENTS

A Personal Letter From The President - ii

|   |            |
|---|------------|
| <b>INTRODUCTION</b>                     | <b>1</b>   |
| 1 How To Use This Manual - 2            |            |
| 2 Introducing GEMINI... - 5             |            |
| <b>GETTING STARTED</b>                  | <b>10</b>  |
| 3 Your First Look At GEMINI - 11        |            |
| 4 A Robot Comes To Life... - 18         |            |
| 5 The Demonstration Program - 25        |            |
| 6 Navigation System Installation - 28   |            |
| <b>DAY-TO-DAY USE</b>                   | <b>40</b>  |
| 7 The Living Loop - 41                  |            |
| 8 Voice Input/Output System (VIOS) - 46 |            |
| 9 SCHEDULER - 61                        |            |
| <b>USING BASIC</b>                      | <b>68</b>  |
| 10 Introduction - 69                    |            |
| 11 General Information - 70             |            |
| 12 Commands Unique To GEMINI BASIC - 80 |            |
| 13 More About GEMINI BASIC - 86         |            |
| <b>MAINTENANCE</b>                      | <b>99</b>  |
| 14 Handle With Care - 100               |            |
| 15 What To Do If... - 102               |            |
| <b>WARRANTY</b>                         | <b>104</b> |
| <b>APPENDIX</b>                         | <b>106</b> |
| List of Figures                         |            |
| List of Tables                          |            |
| List of Pictures                        |            |

## A PERSONAL LETTER FROM THE PRESIDENT

Dear GEMINI Owner,

Welcome to the fascinating world of advanced personal robotics. You have purchased the world's first autonomous robot which is commercially available. You will soon find that your robot has a "life" and "personality" of its own. Its life goals are to entertain, educate, protect and serve humans, and to keep itself alive. Whether you are a beginner or an expert in the field of robotics, you will find GEMINI has much to offer you.

It is our intention to make all hardware and software in the robot open and available to you. We hope that by doing this you will be provided with countless hours of entertainment and education, as well as the opportunity to make significant contributions to the field of personal and industrial robotics. We believe all of this is worth much more than the purchase price of the robot. We do trust, however, that you will respect our software copyrights and hardware patents.

GEMINI is a very complex machine and it will take you some time to fully understand all its hardware and software. To help you unravel the mysteries and to provide you with hours of enjoyment, learning and exploration, we have written two manuals which are intended to address a wide range of users. Our intention is to serve the beginner as well as the expert in the field of robotics, and the manuals were designed with that purpose in mind.

The first manual, the USER'S MANUAL, is designed to get you enjoying GEMINI as quickly as possible. Technical details are purposely kept to a minimum and "how to" information at a maximum. It contains information you will need on how to use the robot from start-up to management of its day-to-day operations.

The second manual, the REFERENCE MANUAL, is designed to educate you and provide factual information required to customize, experiment, explore, and improve the robot as you advance your knowledge. Beginners may find this manual a little "heavy" during the first reading. If so, we suggest you study it and refer to it frequently as it is the key to advancing your knowledge in the field of robotics.

Our goal at ARCTEC SYSTEMS is to make the dream of personal robotics happen in our lifetime. YOU can help make this dream happen. We are making available documented source code listings of most of the 100K bytes of ROM-based software at nominal cost so you can further your education and enjoyment of GEMINI. If you study this software and the material in the USER'S and REFERENCE MANUALS, you will be able to develop new software and hardware enhancements. Share these enhancements with us and other owners and we will do the same. If you want to sell your software or hardware enhancement we will support you...not compete with you. If you just want to share your knowledge with us and others, then send us your discoveries, questions and ideas and we will periodically publish them in a newsletter so all can advance their knowledge.

Please feel free to write or call us at anytime.  
We like robots...and people.

Sincerely yours,

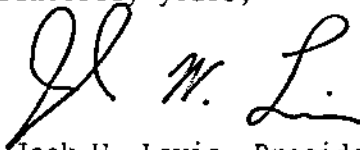
A handwritten signature in cursive script, appearing to read "J. W. L.", written in black ink.

Jack W. Lewis, President  
ARCTEC SYSTEMS, Incorporated  
9104 Red Branch Road  
Columbia, Maryland 21045  
Tele: 301-730-1237

# INTRODUCTION



)

)

)

**SECTION 1**  
**INTRODUCTION**



## CHAPTER 1

### HOW TO USE THIS MANUAL

You are now reading the User's Manual. It contains the information you will need to install GEMINI comfortably and effectively in your home or office. Descriptions of all of GEMINI's operating modes are given. Although GEMINI itself will provide you with much information on the use of its systems, many important details are covered in this manual. We recommend that you (eventually) read it cover-to-cover, for maximum insight into your robot's interesting personality.

If you review the Table of Contents of this manual, you will see that it is divided into five major sections. Section 1, which contains the first two chapters, introduces the user to the robot and its capabilities. These chapters are essential reading and will give you a feel for what GEMINI is all about.

Section 2, called "Getting Started", encompasses Chapters 3-6, and explains all the details of unpacking and assembling the robot, connecting the charger, and setting up the robot navigation system so GEMINI can find its way from room to room. Due to the sensitive nature of GEMINI's electronics, care must be taken during the assembly and this is outlined in Chapters 3 and 4. Chapter 5 explains DEMO, a very entertaining program which allows GEMINI to show off as soon as you turn it on!

Section 3 is entitled "Day-to-Day Use" and contains Chapters 7-9. These chapters tell how GEMINI's many systems function and how you can make the most of them. The "Living Loop," which gives the robot its personality structure, is explained. Also, you are told about the voice input/output system and SCHEDULER, an easy-to-use program which lets you tell GEMINI what to do without ever writing a program!

Section 4 is called "Using BASIC" and is supplied to everyone purchasing GEMINI BASIC. For those of you who wish to do your own programming in a high-level language, Chapters 10-13 are really a programmer's reference manual. GEMINI BASIC, as you will discover, is a very-much-enhanced BASIC which not only contains all the usual commands found in home computers, but also incorporates simple commands which allow you to control the robot from your programs. (Did you realize that you were getting a home computer system as well as a robot?)

Finally, Section 5, entitled "Maintenance," contains Chapters 14-15. It presents the procedure you should follow in the event of a malfunction, and tips on proper care of your robot.

As GEMINI will soon inform you, it is a "very well-rounded robot." We are sure you will find uses for GEMINI that we haven't even thought of. However, included in the two manuals are all the things we HAVE thought of, and want to share with you. So please read them, and keep the volumes in a handy place, because you will probably want to refer to them frequently.

In particular, we believe it is essential you read Sections 1 and 2 of this USER'S MANUAL right now, before you proceed with unpacking. It is very important, for the proper functioning of your robot in the future, that the installation and assembly are done with care. GEMINI is a VERY COMPLEX mixture of electronics and mechanical machinery. Once installed correctly, it should require a minimum of attention. But it is very worthwhile during this initial setup to give it your undivided attention.

Checklists have been provided so that you can keep track of each item as it is tested. It would be best NOT to unpack GEMINI until you are prepared to spend a period of at least 3 to 4 hours of uninterrupted time installing and setting up the navigation system.

NOW. . . we realize that you are getting anxious to actually meet GEMINI, so read on!

## CHAPTER 2

### INTRODUCING GEMINI ...

GEMINI is a truly autonomous robot servant capable of finding its way throughout a typical home in order to carry out scheduled tasks assigned to it by a user. The robot communicates with its human family by voice and/or written text using an on-board liquid crystal display (40 characters by 8 lines). You communicate with the robot by voice, an on-board keyboard (or terminal), or a remote communication system computer connected to a personal computer or a telephone. GEMINI is about 48 inches tall, 20 inches in diameter at its base, and weighs about 70 lbs.

The robot has many human-like qualities. It periodically monitors its power system and issues warnings when battery voltages go below a threshold level. If voltages become critically low, GEMINI issues a one-minute warning, then automatically seeks out its battery charging station.

In addition, GEMINI continually monitors the on-board real-time clock, to determine if a task is scheduled to be carried out, while watching for input from any of the user entry ports--voice input, keyboard input, built-in function keys, or remote communication system.

Scheduled tasks are entered into the robot through the SCHEDULER program, which may be accessed by the keyboard, Function Key #2, or the remote communicator. This program allows a user with no prior programming experience to assign the robot tasks to be performed in a certain room or rooms at a certain time or time interval. These tasks may include wake-up calls, reminders, security patrols, operating lights and appliances, telling stories, reciting poetry, and more.

The robot carries out these tasks by navigating through the rooms and doors of the house with a unique, inexpensive, and easily installed system of infrared coded beacons and door edge reflectors.

GEMINI's movement is made possible by a four-wheel drive propulsion system. This system provides the robot with the ability to move over heavy shag rugs without stalling, and over door sills without being knocked off course. GEMINI has 16 running speeds. (For safety purposes, none are faster than a medium walk.)

GEMINI is equipped with a great many sensors to assist in navigating through the house and detecting problems when on security patrols. Most of these sensors are located in the head (which rotates 359 degrees). They include a room beacon infrared detector, door edge infrared detector, ultrasonic motion detector, smoke detector, light detector, and sound level detector. There are a total of nine ultrasonic collision avoidance and navigation sonars. The circular base is entirely ringed with a four segment bumper to allow the robot to know when it has made physical contact with an object undetected by its sonars.

Voice communications are initiated by the robot when the power is first turned on. GEMINI's voice makes use of the latest Silicon Systems SSI-263 unlimited vocabulary speech synthesizer. You may select one of several different voices for the robot. A text-to-speech algorithm is also included as part of the voice software. This allows you to enter voice message memos as text when using SCHEDULER or BASIC.

GEMINI also contains an accurate, speaker dependent, language independent, adaptive voice recognition system. In addition, a unique VOice Command Language - VOCOL (optional) - is available for commanding many of GEMINI's actions. Training

the robot to recognize your voice is effortlessly carried out by the robot itself. GEMINI tells you what to say using its voice and the liquid crystal display. Once trained, the robot remembers that you trained it, and constantly updates the word recognition parameters as you use them. This adaptive voice recognition feature actually allows GEMINI to improve the recognition of your spoken words the more you talk to it.

The optional on-board keyboard is a full typewriter-style keyboard which may be used in a cordless manner via its infrared communications link, or with a conventional telephone-type extension cord. After use, the keyboard stores conveniently inside the robot. If you did not purchase the keyboard a dumb terminal may be connected via the RS232 link. A simple switch setting is all that is required.

The main computer onboard GEMINI contains sophisticated software to suit every user's programming level. DEMO, accessed by Function Key #1 or from the keyboard, is a menu-driven demonstration program in ROM (Read Only Memory) which lets GEMINI introduce you to a pushbutton sampling of its talents. This is a handy way to show off your robot to friends, with no programming on your part at all.

The SCHEDULER program, also in ROM, allows a user with no programming experience to make the robot perform useful and entertaining tasks around the home. For the beginner and intermediate, there is GEMINI BASIC in ROM. This is the familiar BASIC high level programming language expanded to include the capability to write complex programs for the robot that involve movement, sensor input, and remote control of devices. For the more skilled programmer, there is a MONITOR program in ROM which provides the user access to the new CMOS 65C02 microprocessor and on-board machine language subroutines. The MONITOR also contains a built-in 65C02 disassembler for program debugging.

Hardware located on the main computer is quite extensive. There is a real-time clock, 16-channel analog-to-digital converter, random number generator, an RS232 serial port, a Centronics style parallel printer port, and a high-speed bi-directional parallel data transfer port for program development using another computer, all with built in driver programs. Memory consists of up to 56K of battery-backed CMOS RAM (Random Access Memory) and up to 63K of ROM. There are also four slots for user experimentation and new peripherals, and room for an optional CMOS 3-1/2 inch floppy disk drive or wafer endless tape drive. The entire computer uses the new low power, high-speed, CMOS logic so the robot will only need to recharge its batteries infrequently.

In addition to the main computer, there are three other auxiliary computers, each with its own RAM and ROM, to help with all the chores the robot must perform.

The propulsion system is completely controlled by its own microcomputer system (PROCON) which is under the direct command of the main computer. This computer controls a four-wheel drive system using pulse width modulation techniques and infrared LED feedback for speed and distance control. The robot is able to track in a nearly perfect straight line for precisely commanded distances either forward or backward with accuracy around  $\pm 1$  inch over 10's of feet. PROCON constantly monitors the four contact bumpers on the base (when they are activated) and will stop the robot if any bumper makes contact with an object. This computer contains 2K of RAM and 2K of ROM, and can be turned on and off by the main computer. This computer also uses all high-speed CMOS logic.

The second auxiliary microcomputer handles voice input/output and sound generation (VIOS). The main computer can command VIOS to enter one of three modes: (1) voice recognition; (2) voice synthesis; and (3) sound synthesis. Voice recognition allows for recognition of up to 256 words or short phrases in 16 groups of 16 words each. Each group may be individually trained and all groups use the adaptive voice recognition updating feature. The voice synthesis mode provides a versatile array of programs. It can convert typed text into spoken words, sing, and change its voice. The sound generator contains numerous canned sound effects including a gunshot, chimes and others. GEMINI can also sing while accompanying itself on a synthesized piano! This computer uses high-speed CMOS logic for almost all of its parts.

The third auxiliary computer (optional) is not located on the robot. Called the Remote Communication System computer (RCS), it is designed to handle remote communications with the robot via a radio link. The RCS can be controlled directly by the robot or the robot can be called by the RCS. The latter feature allows the RCS to be used as a remote entry device. The RCS is equipped with a BSR controller which allows the robot to turn on/off lights, appliances, security devices, etc. The robot could also be programmed to turn on/off a personal computer or printer. GEMINI could then command the RCS to connect with the computer or printer, and thus upload or download data into its memory. The RCS may also be commanded to hook to its on board modem, allowing GEMINI to communicate by telephone.

Heard enough yet? There's more, but this should give you a pretty good overall idea of GEMINI's versatility and depth.

But, a robot must be USED to be appreciated, so turn the page and we'll get on with the show...



# GETTING STARTED

)

)

)

**SECTION 2**  
**GETTING STARTED**

## CHAPTER 3

### YOUR FIRST LOOK AT GEMINI

The GEMINI System will arrive at its new home in four cartons. The number on the carton relates to the sequence in assembling the robot. Box #1 contains the accessories. Boxes #2, #3 and #4 hold the base, torso and head, respectively. To assemble GEMINI you will need an 11/32" wrench, pliers and a screwdriver. An assistant is recommended.

Since you are reading this manual, you have opened the correct box. If a keyboard, additional room beacons and/or door edge reflectors were purchased, they should be included in this box. Please check the packing list to verify that all parts are there and then set this box aside. You will need it again after the robot is assembled.

**NOTE:** If you have not read Chapter 14, "Handle with Care" in Section 5, please do before continuing.

Now...to assemble a robot. First, open Box #2 and remove the base section. Be careful, the base contains the batteries and is heavy. The front of the base is identified by the brass plated bumper, known as the "charging bumper."

This will be important when positioning the torso. Located on the top of the base are eight shock mount studs for attaching the torso. Using the 11/32" wrench, remove the nuts and set them aside until the torso is in position.

GEMINI's torso, in the container marked Box #3, is the next section to unpack. Making sure that the barrel is right side up, remove the locking safety wire with pliers. Pivot the lock clockwise to point at six o'clock and then pull the handle towards you, releasing the aluminum

ring. Now, carefully slide GEMINI's torso out of the container. If you ever plan to transport GEMINI to other locations, these containers should be saved for your convenience. The front of the torso can be identified by the multiple sonars and dual speakers. Position the torso for the same orientation as the base.

At this point, it is necessary to remove the plastic shell on the torso. To do this, simply remove the three plastic finger screws on each side of the torso. These can be seen in Figure 3.1. There are four screws remaining, two on the lower front and two on the lower back. While holding the shell in position, remove the front lower screws and the shell should come off. Repeat for the back side.

Taped to the lower torso aluminum plate are jumpers for battery backing of the Main Computer and VIOS. Locate the green and white battery on each board and slide the connector onto J20 on the Main Computer and J5 on VIOS.

At this point in the assembly, a second person is helpful.

While carefully handling the torso so as not to touch the electronic components, guide the base wire harness through the opening in the large aluminum disc. Align the holes with the eight shock mount screws on the base and secure with the hex nuts. Connect the base connector J1 to the large torso connector marked J4, as shown in Picture 3-1.

The last step is to connect the head which is in the remaining box marked #4. On the underneath side there should be a small Allen wrench attached. Please find and remove. This is used to first remove the brass gear and then replace it once the head is in position. To remove the gear, simply insert the wrench in the holes and turn

FIGURE 3.1

EXTERIOR ABS PLASTIC SHELLS

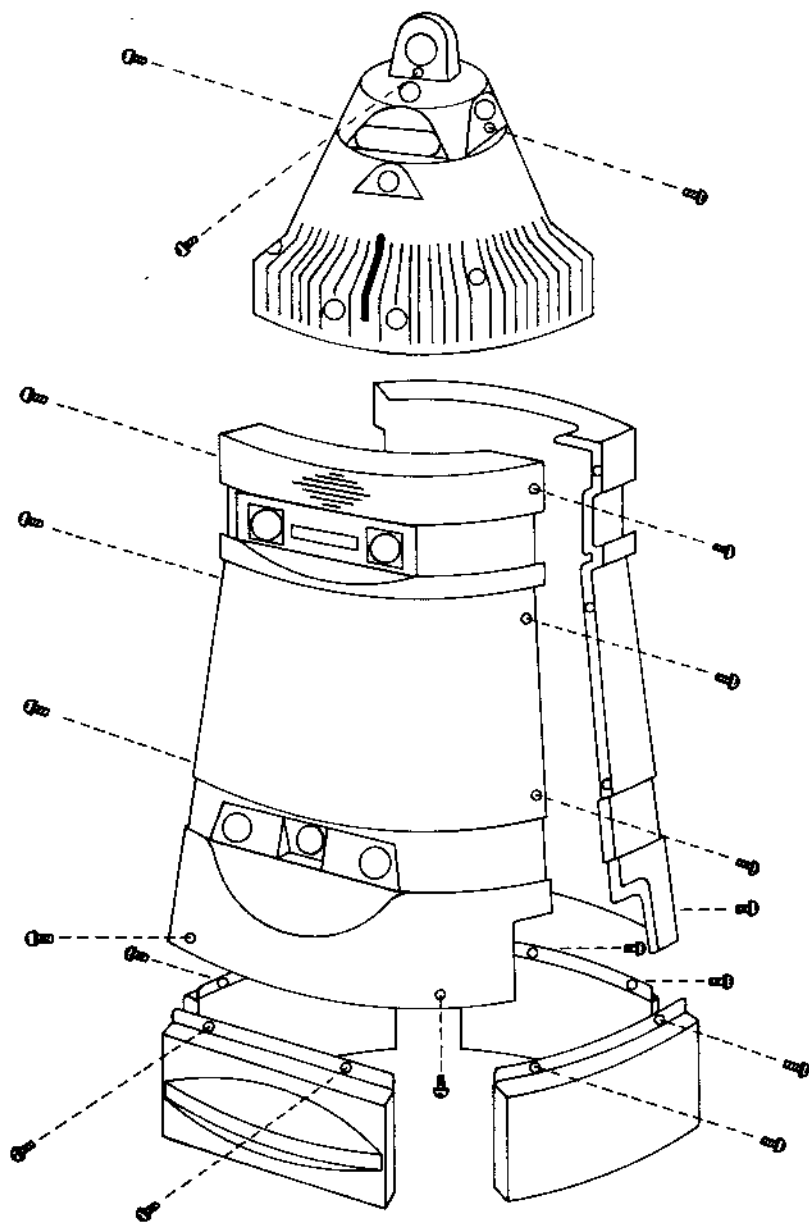

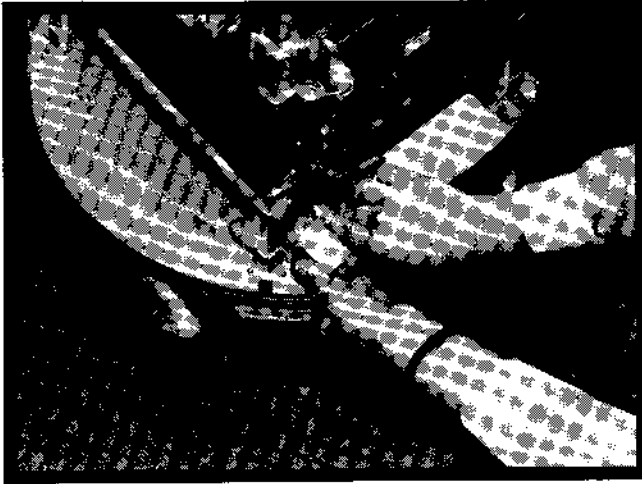

**PICTURE 3.1**

**TORSO/BASE HARNESS CONNECTION**

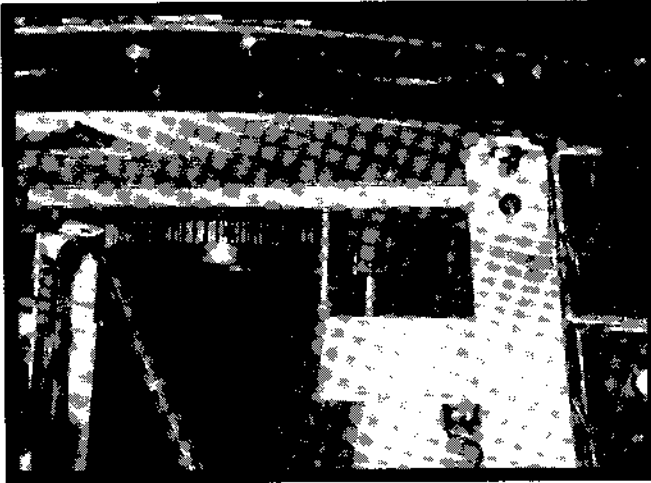

**PICTURE 3.2**

**PROPER POSITIONING OF BRASS HEAD GEAR**

counter clockwise until loose. Position the head onto the torso by sliding the brass bushing through the hole and replace the gear underneath. Refer to picture 3.2 for proper positioning of the brass gear. Usin the same Allen wrench but turning clockwise, secure the gear in place. Be sure to store the wrench in a safe place for future use. To complete the head assembly, the plastic shell must be removed. Only three screws hold it on as pictured in Figure 3.1. Remove these and lift the shell off. Guide the torso harness with connector J1 up through the hold in the bottom of the head plate and connect with the head connector marked J1.

If a terminal is to be used instead of the GEMINI keyboard, switch settings on the main computer must be changed. The switches are shown below.

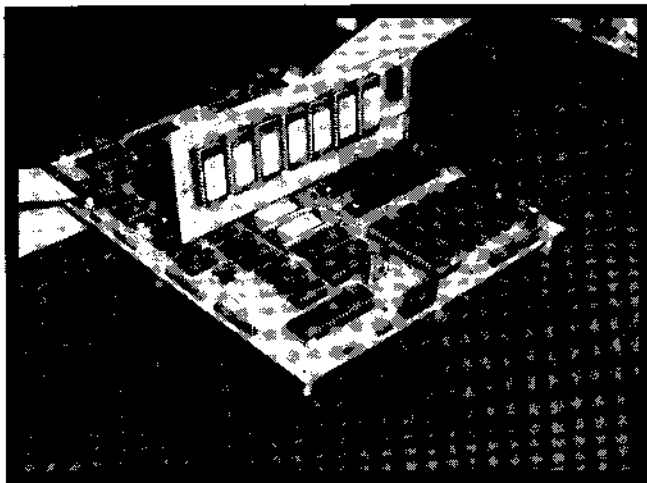

PICTURE 3.3

MAIN COMPUTER SWITCHES

The following chart lists the proper switch settings for each terminal.

| <u>SW1</u> |  | <u>CONDITION</u> |
|------------|--|------------------|
| On         |  | Terminal         |
| Off        |  | Keyboard         |

| <u>SW2</u> | <u>SW3</u> | <u>BAUD RATE</u> |
|------------|------------|------------------|
| Off        | Off        | 300              |
| On         | Off        | 600              |
| Off        | On         | 1200             |
| On         | On         | 2400             |

Finally, replace the plastic shells and the assembly is complete. This is very important for the protection of GEMINI's circuitry.

Congratulations, you now have a life sized robot!



As with any newborn, GEMINI must be fed. Remove and unpack the charger from Box #1. You should also retrieve the black static mat from the box. The next step is for you to decide where GEMINI's "home" base is going to be placed. A central location in GEMINI's environment is suggested but under no means required. You can put GEMINI's home base anywhere you want. The charger is designed to be placed along a straight wall or in the corner of a room. The only consideration in its placement is that there be at least four feet of clear space in front of the charger. Once you have decided on the charger's location, place the static mat on the floor first and then the charger on top of the mat. Connect the charger static line to the screw on the back left side of the charger. This will help dissipate any static charge built-up in the robot via the mat and static line.

Having set up a home base for GEMINI, you must now provide an address for this location so GEMINI can always find "home". This is done by installing a room beacon directly above the charger. The room beacon can be found in the same box that the charger and this manual were found. On the back side of the beacons is a set of switches. The one with switch 1 in the ON position and all others in the OFF position is the home beacon. It has been tuned so GEMINI recognizes this as its home-addressed beacon. The beacon can now be positioned on the wall directly behind the charger and about 42 inches above the surface GEMINI will be running on when it maneuvers to come home.

## CHAPTER 4

### A ROBOT COMES TO LIFE...

When GEMINI is first powered up, it will introduce itself and perform a series of initialization tasks. These tasks are for the purpose of determining that GEMINI's systems are functioning properly.

To assist you in identifying switches and other items referred to during the system checks, we have included sketches of the robot's inner structure. Figure 4.1 is a front view and Figure 4.2 is a rear view. Both are located at the end of this chapter.

Before turning on the power, make sure you have completed the following items:

- 1) Review the Checklist at the end of this chapter. This will help you when GEMINI starts its system checks. Have a pencil for filling it in.

- 2) Have the keyboard attached and turned on.

- 3) Make sure the robot is properly connected to the charger. If it is not, reposition the robot so as to "mate" the front charger bumper with the charger brass plates. The charger indicator light, located as shown in Figure 4.2, should be lit.

- 4) Make sure you position yourself so that you can read the LCD screen in the robot's back. (The angle of the display can be adjusted by turning the wheel located as shown in Figure 4.2). When GEMINI speaks, its words will appear on the screen. This is to help you become accustomed to the synthesized voice. At first you may have

a little difficulty understanding GEMINI--it speaks with a robot "accent"--but in time you will find it quite understandable.

Now you are ready to bring GEMINI to life. The power switch is located as shown in the accompanying Figure 4.2. Flip it on.

If you have purchased the Life Lites option, also shown in Figure 4.1, they should light up. GEMINI will now enter the initialization and checkout modes. Take note of any item that GEMINI diagnoses as malfunctioning and fill in on the checklist.

1) The first system to be checked is the VIOS computer which, you may recall, stands for Voice Input/Output and Sound generation computer. If GEMINI is speaking to you, that is a good indication that VIOS is working! GEMINI then checks out the RAM and ROM memory chips on the VIOS board, and the speech and sound chips. It will let you know if any of them are faulty.

2) A check of three battery voltages is performed. These should all be between 11 and 14 volts.

3) The ROM card is the next item to be checked. During this check, any ROMs not in place are reported as bad or missing. This is okay. The basic robot will report ROMs 3, 5 and 7, while the EDUCATIONAL SYSTEM (w/Basic and Vocol) reports ROM 7. A complete board should pass the test.

4) Next, the main computers' ROM and RAM are checked, followed by a report on the total amount of available RAM.

5) A search for a disk or tape is now performed and reported. If neither of these peripherals is attached, the robot will report "I/O ERROR 32".

6) GEMINI will ask you to test the keyboard by pressing "K." If a "K" is not received, check to see that it's turned on.

The IR link will be tested. Be sure to aim at the IR receiver located just above the LCD.

7) Next, the real-time clock must be set, in the format indicated by GEMINI. When you have entered the time and date, it will be displayed on the screen, and you will be asked to verify whether or not it is correct. The seconds should be changing.

8) Now, a check of the PROpulsion CONTrol (PROCON) computer is performed. The RAM chip, left motor, and right motor are checked.

9) The bumpers are checked in a counter clockwise rotation starting with the front charging bumper. You will be asked to press each bumper so the robot can verify its operation. If a bumper is not working, the robot will rotate slightly for about 5 seconds and report which bumper it is.

10) Each of the sonars is checked in turn, and a range in feet is reported. As each sonar is fired, hold your hand, a book, or other flat object approximately one to two feet in front of it. (Sonar locations are shown in Figures 4.1 and 4.2). The range given by GEMINI should match the distance from the sonar to your hand or object. Record each range in the space provided on the checklist.

**NOTE:** If you do not hold anything in front of the sonar and if there is no wall or other surface within the sonar's range, a false reading may be given. Don't be disturbed by this.

11) A check of the head drive system is done next, followed by a search for room beacons and door edge detectors. Don't worry if the beacon is not picked up, a height adjustment will probably solve the problem.

12) The motion detector is the last thing to be tested. When instructed, move your hand in front of the motion detector. The location is shown in Figure 4.1.

When initialization is completed, GEMINI goes directly into the demonstration program. At last, you can actually USE your robot!

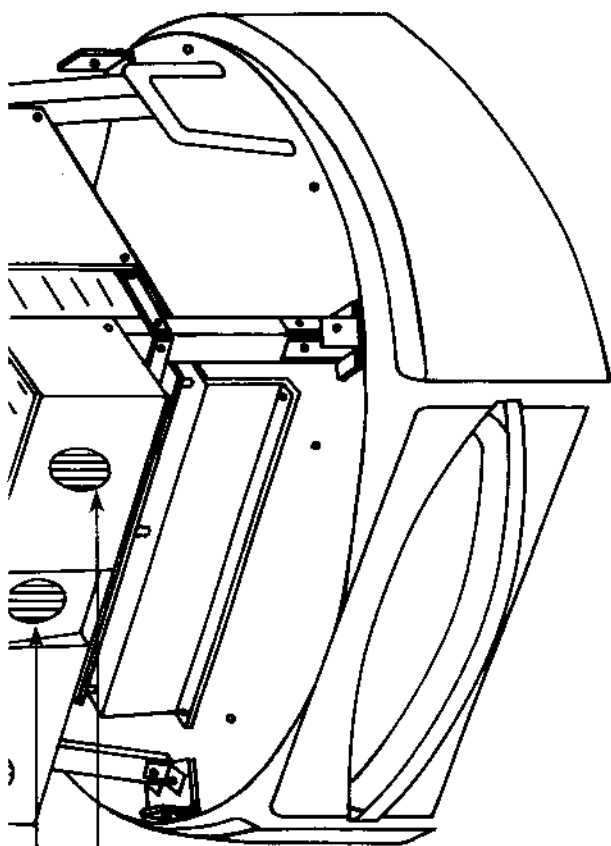

SONAR 7

SONAR 4

LED CHARGING  
INDICATOR

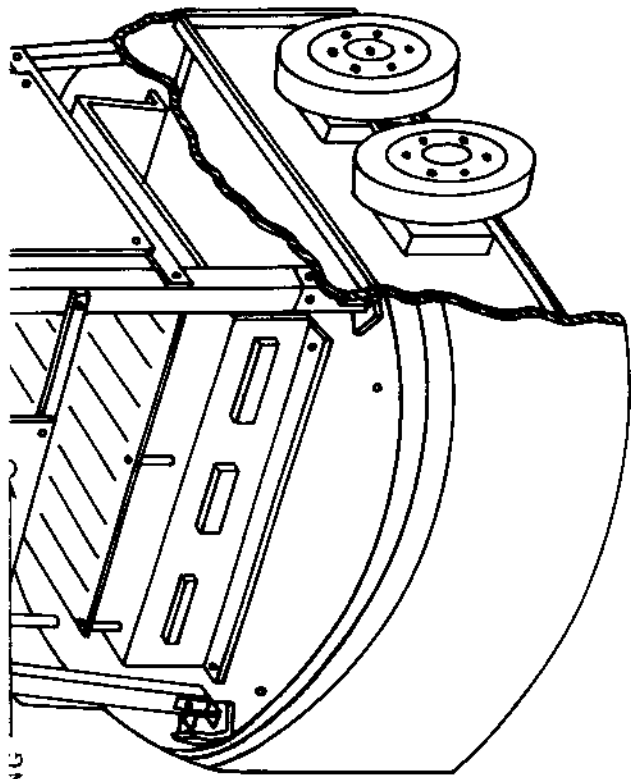

### GEMINI CHECKLIST

Please complete the following items as GEMINI does its system check.

VLOS

\_\_\_ volts LOGIC BATTERY

\_\_\_ volts RIGHT MOTOR BATTERY

\_\_\_ volts LEFT MOTOR BATTERY

ROM CARD

MAIN FUEL DAM

\_\_\_ ft. HEAD ROTATION

\_\_\_ ft. BEACON DETECTOR

\_\_\_ ft. DOOR EDGE DETECTOR

\_\_\_ ft. MOTION DETECTOR

DATE: \_\_\_\_\_



## CHAPTER 5

### THE DEMONSTRATION PROGRAM

GEMINI's Demonstration Program (DEMO) is an easy to use program designed to show off the varied talents of your robot. It is so easy to use that it does not even require a keyboard for input. The function keys on the robot are all that is needed and as for talent, GEMINI speaks for itself!

When GEMINI enters DEMO, a menu is printed on the screen. It looks like this:

- 1 - PLAY IT AGAIN, GEMINI!
- 2 - AUTHOR! AUTHOR!
- 3 - THE SENSUAL ROBOT
- 4 - ACROBOTICS
- 5 - EXIT

The numbers on the left refer to the function keys located just above the screen, or the keyboard keys 1-5. Key 1 is for demonstrating GEMINI's musical and sound generating abilities; key 2 allows it to show off its literary talents; key 3 is not as kinky as it sounds--it merely shows off your robot's use of its sensors; key 4--"Acrobotics"--simply refers to GEMINI's agility and mobility.

Each of these keys, when pressed, causes another menu to appear, from which you may select the specific task you wish GEMINI to perform. These tasks include playing music, reciting poems and stories, moving about, and recognizing your voice. When the task is complete GEMINI returns to the menu for another selection. If no selection is made within a minute, GEMINI will exit DEMO and enter the LIFE MENU.

SELECTION 1 - PLAY IT AGAIN, GEMINI!

SOUND AND MUSIC MENU

- 1 - STAR WARS
- 2 - NATIONAL ANTHEM
- 3 - OCEAN SOUNDS
- 4 - GUNSHOT
- 5 - EXIT

SELECTION 2 - AUTHOR! AUTHOR!

AUTHOR MENU

- 1 - POET
- 2 - STORYTELLER
- 3 - EXIT

SELECTION 3 - THE SENSUAL ROBOT

THE SENSUAL ROBOT MENU

- 1 - SIGHT AND SOUND
- 2 - TIME
- 3 - TEMPERATURE
- 4 - BAROMETRIC PRESSURE
- 5 - EXIT

SELECTION 4 - ACROBOTICS

ACROBOTICS MENU

- 1 - DANCE
- 2 - VOICE CONTROL
- 3 - BASIC CONTROL
- 4 - SOMERSAULT
- 5 - EXIT

You can keep GEMINI performing in DEMO as long as you like. When you are ready to move on, press key 5--EXIT. When this key is pressed, the robot checks to see if the navigation system room beacons have been set up. Since this has not yet been done (I am assuming that you have just turned GEMINI on for the first time), the robot will ask if you wish to do it now. If the answer is "Yes," type "Y" or "Yes".

**IMPORTANT!** If you do not want to set up the room beacons at this time, type "N" or "NO." GEMINI will then drop into its Living Loop (see Chapter 7). When you are ready to install the navigation system, just type "R", and GEMINI will begin requesting data for the room tables.

If you are now ready to set up the beacons and let GEMINI start to find its way around, just turn the page...

**NOTE:** Once GEMINI has entered the Living Loop and the Life Menu is displayed on the screen, the DEMO program can be entered at any time by pressing Function Key 1 or key "1" on the keyboard. (The initialization and system checkout are only performed when the power is first turned on.)

## CHAPTER 6

### NAVIGATION SYSTEM INSTALLATION

GEMINI is the first personal robot to be equipped with a complete built-in navigation system. In arriving at the system design, our engineers pondered the method used by humans to find their way around a house unfamiliar to them. Think for a moment how your own "navigation system" would operate in such a situation. Imagine yourself arriving at a party held in your friend's new house. You enter by the front door into a foyer. You want to put your potato chips and dip in the kitchen, so you search for a likely-looking door. You go through the door and look to see if you are in the kitchen. If not, you determine whether this is a room that would logically be located near the kitchen, such as the dining room. If so, you look for another door which might lead to the kitchen. You continue in this manner until you find a path, through doors and rooms, which leads you to the kitchen. As you follow along your path, you will continually avoid obstacles.

Essentially, GEMINI's navigation system operates the same way. Each room contains a small, attractively packaged beacon, which sends out a logic code from 1 to 15. GEMINI is able to determine what room it is in by decoding the beacon number. When the robot is requested to move to another room, it first scans the room for a beacon. It then searches for all the doors (each marked with a small door edge reflector). Using information previously entered by the user, GEMINI is able to determine into which room each door leads.

Next, using advanced artificial intelligence programming techniques, GEMINI finds the shortest path (least number of doors) to the desired room. The robot then proceeds to follow this path. Using the door edge reflectors and the sonars, the robot performs a large number of trigonometric calculations to position itself correctly and maneuver through the doorway. GEMINI immediately checks the new room beacon to make sure it is where it expected to be. If not, it backs up and repeats the scanning procedure. As it moves along a path, it uses the front body sonars and base bumpers to avoid obstacles and possible contact with objects. If it discovers an obstacle in its path, it searches for a way around it. GEMINI will make up to three attempts to get to the right room.

Before the system can be implemented, you must install the room beacons and door edge reflectors. When you first set up the battery charger station, you should have installed its "home" beacon (code "1") at the same time. (Consult Chapter 3 for details.) The room in which the charger is located is always Room #1. It needs no additional beacon.

The other room numbers should be assigned by you in a logical manner. (It helps to sketch a floor plan of your house showing all the rooms and doors.) A location should be chosen in each room for the coded beacon. It should be in a position such that the beacon can be seen from all the doors GEMINI will be using.

One door edge reflector must be placed as close as possible to the edge of each door. It may be placed on either the right or left side. On your floor plan sketch, after you have numbered all the rooms and marked the location of each coded room beacon, you must next number the doors in each room, CLOCKWISE from the beacon. This is very important for GEMINI's navigation.

From the robot's point-of-view, a door is defined as an opening which leads into another room (or corridor). Doors which are usually closed or which lead into places that you don't wish your robot to go (such as into closets or out-of-doors) should not be marked with a reflector.

### SPECIAL CASES

If all buildings had only rectangular rooms connected by small doorways, setting up room beacons and door edge reflectors would be straightforward. However, architects have filled buildings with corridors, L-shaped rooms and very wide doorways.

To set up the room beacons, some judgements must be made regarding these special cases. For example, in Figure 6.1, the living room and dining room have a very wide doorway, making it necessary to classify this as one room. Another unusual situation exists in the foyer/hallway. Since the beacon in the hallway would be visible from the foyer doorways, it is necessary to consider this an L-shaped room and identify it as a hallway in the robot's room tables (there is no special classification for L-shaped rooms therefore H=hallway is used). These cases also require the appropriate response to positioning for visibility of all door edge reflectors. Both should be entered as a room where all the reflectors can only be seen from the beacon. Some experimentation may be necessary in these special cases.

Table 6.1 provides a place for you to list the room numbers and names, so they will be handy in case you forget the order of assignment. It also includes the beacon switch settings for each room number. Please fill them in now! (Use a pencil, in case you need to make changes later.)

Now you are ready to provide GEMINI with the data for the room tables. If you are in the LIFE MENU, type "R" to enter this data. The robot will display on the screen and say, "IS THIS HALLWAY OR ROOM? TYPE H FOR A HALLWAY OR R FOR A ROOM." After typing the appropriate key, GEMINI will say "ENTER BEACON CODE FOR THIS ROOM." Simply type in the number you have set the beacon for in this room.

For most rectangular rooms, all the door reflectors should be able to be seen from most anywhere in the room. However, in some cases, there may be only a small area in the room from which all the reflectors can be seen. The room table entry program will say: "IF ALL REFLECTORS CAN BE SEEN FROM ROOM CENTER, TYPE C. IF ALL REFLECTORS CAN ONLY BE SEEN FROM THE ROOM BEACON, TYPE B." Give appropriate response for this room.

GEMINI will then ask for the number of doors in this room; which room is on the other side of each door; on which side of the door the reflector is located (L or R), and a rough estimate of the width of each door in inches. Note that a door can have different numbers, depending on which room the door is seen from. The robot will ask for this information for each room.

When you have entered all the information, GEMINI's main computer now moves into the Living Loop, and the LIFE MENU appears on the screen. (The next section will tell you more about the Living Loop.)

You can now proceed with beacon and reflector installation. Door reflectors should be installed about 3-1/2 feet up from the floor, as close to the door edge as possible. Room beacons should be installed in the same manner, with the center of the beacon approximately 38" up from the floor.

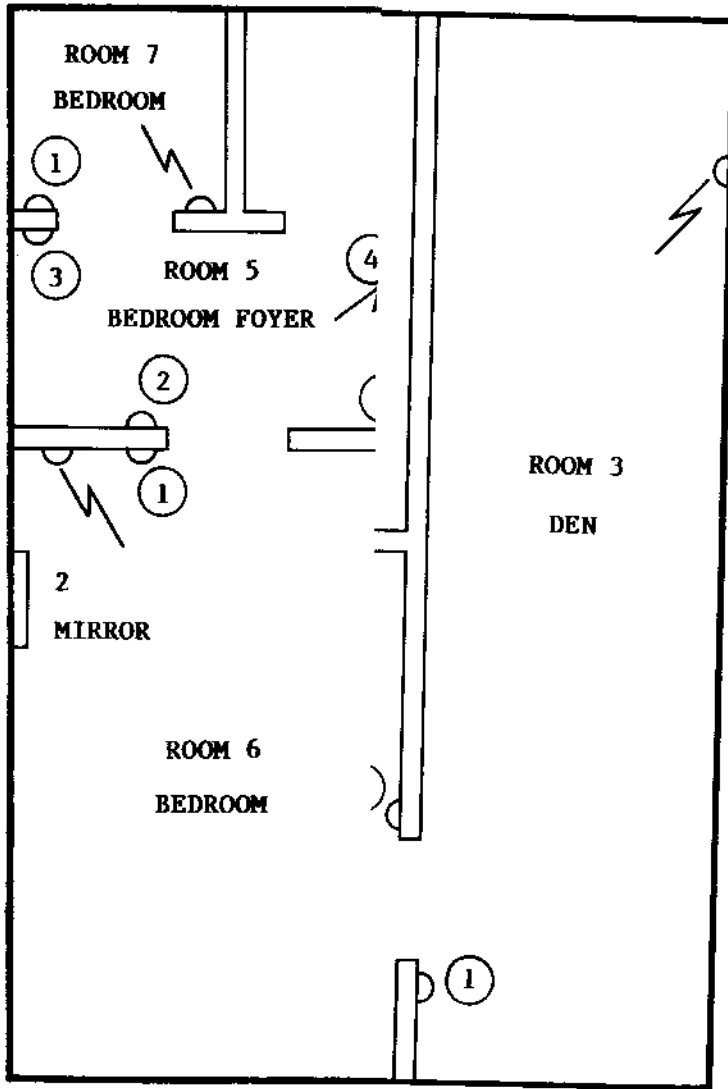



## THINGS TO REMEMBER DURING INSTALLATION

Some guidelines to follow when setting up the room beacons.

1. The Room Beacon should be visible from all doors through which GEMINI can enter the room. Please refer to Figure 6.1. In Room 2, the living room/dining room combination, a single beacon could not be visible from both door 1 and door 3. In this case, two beacons are set to Code 2 and placed in the room such that the relative position of the doors in a clockwise rotation is identical.

2. To make sure GEMINI can see the beacon, position it about four feet in front of the doorway. While in the LIFE MENU, type "L", and GEMINI will search for the beacon and identify what is found. If it misses the beacon, try adjusting the height. If this does not work, move the beacon to another location.

3. If possible, position the door edge reflectors on the opposite side the door is hinged on. This may help GEMINI to pick up the reflector. To check this, type "M" from the Living Loop and GEMINI will report the number of reflectors found.

4. GEMINI may occasionally pick up reflections from mirrors, light switch covers, windows, and other shiny objects. In most cases, these are only detected from a small area in the room and therefore not a problem. If the robot picks up an extra reflection, it will reposition itself and try again.

If a reflection is picked up fairly frequently, it may be desirable to cover it up. If an unwanted reflection is picked up constantly from a majority of the area in the room, it may be desirable to enter the reflection in the room tables as another door leading to a room the robot will never move to. For example, in Room 6 in Figure 6.1 the full length mirror gives a reflection picked up everywhere in the room. Since it is not desirable to cover this mirror, it is entered as Door 2 leading to Room 9 in this house. Since there is actually no Room 9, care must be taken to avoid entering any other reflections as doors leading to Room 9. This could cause the robot to find a path through this fictitious room when it navigates.

5. Position the robot (either in the center of the room or at the room beacon) where all the door edge reflectors should be visible and type "M" from the LIFE MENU for verification. Continue adjustments until the correct number of reflectors is identified by the robot.

**IMPORTANT:** We recommend installing reflectors and beacons in stages, instead of all at once! Then if GEMINI has any problems you can correct them before you proceed.

If at any time you wish to make changes in the room table data, type "R." You don't have to re-enter the whole data table. Simply hit "RETURN" after each data request if you want to leave previous data entries unchanged. When you reach the point in the table where you want to make a change, type in the new data.

TABLE 6.1

## ROOM BEACON ASSIGNMENTS

| ROOM<br>NUMBER | ROOM<br>NAME | SWITCH SETTING |          |          |          |
|----------------|--------------|----------------|----------|----------|----------|
|                |              | <u>1</u>       | <u>2</u> | <u>3</u> | <u>4</u> |
| 1              | "HOME"       | ON             | OFF      | OFF      | OFF      |
| 2              |              | OFF            | ON       | OFF      | OFF      |
| 3              |              | ON             | ON       | OFF      | OFF      |
| 4              |              | OFF            | OFF      | ON       | OFF      |
| 5              |              | ON             | OFF      | ON       | OFF      |
| 6              |              | OFF            | ON       | ON       | OFF      |
| 7              |              | ON             | ON       | ON       | OFF      |
| 8              |              | OFF            | OFF      | OFF      | ON       |
| 9              |              | ON             | OFF      | OFF      | ON       |
| 10             |              | OFF            | ON       | OFF      | ON       |
| 11             |              | ON             | ON       | OFF      | ON       |
| 12             |              | OFF            | OFF      | ON       | ON       |
| 13             |              | ON             | OFF      | ON       | ON       |
| 14             |              | OFF            | ON       | ON       | ON       |
| 15             |              | ON             | ON       | ON       | ON       |

## WHAT GEMINI WILL DO WHEN NAVIGATING

### ROOM TO ROOM

The navigation software has extensive obstacle avoidance capabilities. However, it adds a considerable amount of time to the process of moving from room to room if there are many obstacles to avoid. It is recommended that frequently used paths be kept clear for GEMINI. It is also desirable to keep all doors opened wide.

As soon as a command is given to GEMINI to move to another room, the first thing it will do is scan for the room beacon with its head. If it finds the beacon, the robot will slow its head down as it moves across the beacon. Then GEMINI will briefly pause and continue. If it doesn't find the beacon, GEMINI will scan the room with its sonars to attempt to find the room center. Once the location of the center is found, GEMINI moves as close to this area as it can. Once there, it searches for the beacon again.

Once the beacon is found, GEMINI consults the room tables and decides if it is necessary to move to the beacon to scan for reflectors. Once in position, it proceeds to do a complete scan of the room to find all reflectors. If the number of reflections does not agree with the number in the room tables, GEMINI will either "move to room center" again or reposition around the beacon.

When GEMINI finds the right number of reflections, the robot turns its body to line up with the correct reflector. The robot will then attempt to move to within three feet of the reflector. If an obstacle is encountered while performing this move, the robot should detect it with its sonars or bumpers. GEMINI will back up about

six inches to be clear of the obstacle, and then turn left 90 degrees. It will make six successive 30 degree right turns. Between each turn, the robot will fire its sonars. This shows it a clear direction to move around the obstacle. The robot then turns to the clear direction and moves a few feet while tracking the reflector. The robot then turns back toward the reflector and proceeds to try to move to it again.

If GEMINI is in a hallway, the only obstacles that should be present are walls. If it hits a wall, the robot will back up six inches, turn 30 degrees to a clear direction, move forward two feet, then continue towards the reflector.

Once at the door, the robot scans the opening with its head sonars to detect its edges. If it doesn't find the edges, the robot repositions and tries again. When the correct edges are found, the robot uses trigonometry to calculate the door center. The robot then turns and moves to this center. Once at the center, the robot turns again to be facing the door. It takes one more scan with its sonars, makes one final correcting turn, and moves through the doorway.

After moving through the doorway, the robot will be two to four feet inside the next room. GEMINI will search for the room beacon. If it is not found, it will move forward two feet and search again. If still no beacon is found, the robot will go back through the doorway and try again. If the beacon is found, the robot will proceed to navigate from this room to the next room on the path until the desired room is reached.

## GOING HOME

When moving to its charger, GEMINI first moves to the charger room in the same manner as above. The robot then lines itself up with the charger beacon and moves to within three feet of it. This move is done in exactly the same manner as the move to door reflectors. Once this is done, the robot then turns back towards the beacon again and inches forward until on charge.

GEMINI will make 2-3 attempts at each stage in navigation. If it is unsuccessful, it returns with one of the error codes listed in Section 4 on BASIC.

PLEASE be patient with GEMINI as it navigates through the house. You should not expect it to find its way around at human speeds. The robot possesses a much less sophisticated "navigation system" than we humans, with far fewer sensors and inferior computing capabilities, compared to the human brain.

GEMINI may occasionally get "stuck" or "lost", and will sound a bell alerting you. However, it is our experience that, approximately 90% of the time, the robot will manage to reach its destination.

The system works best in an "ideal" situation i.e. perfectly square, uncluttered rooms, with no mirrors or other reflective surfaces to give false reflections. However, this "ideal" environment does not exist in real life. Real homes and offices have oddly-shaped rooms, unexpected obstructions, and shiny surfaces which may interfere with reflector detection. It will probably take time (and patience) for you to work the "bugs" out of GEMINI's navigation in your environment.

Our engineers are continuing to experiment in the field of robot navigation. As we make further improvements and refinements, we will pass the new navigation technology on to you, the "pioneer" personal robot owner.

We hope you too will experiment with your robot's navigation, and will share your ideas and findings with us.

DAY TO DAY USE



**SECTION 3**  
**DAY-TO-DAY USE**

## CHAPTER 7

### THE LIVING LOOP

The program which we call the "Living Loop" is what gives the GEMINI robot its ability to function autonomously. In designing the robot, one of our primary concerns was that it be an autonomous being which is always "alive" and available to humans, with very little extra effort on their part. We wanted GEMINI to be almost like another member of the family.

For this to be the case, we realized that, first and foremost, the robot would need to keep its batteries charged, without assistance from its user.

Secondly, we asked ourselves what it is that people do to fill up time during the day that could be emulated by a robot. The answer we arrived at was that we humans store a general schedule in our minds of what we must accomplish each day--meetings, chores, eating, etc.--and we keep track of the time and try to meet our mental schedule. If other things come up, such as friends dropping over, or the car breaking down, we handle them as necessary and try to fit them within our schedule. Out of these musings came the concept of GEMINI's Living Loop.

The Living Loop is a program which is continuously run by GEMINI's main computer, when it is not being occupied by other tasks. It performs the following functions.

#### RECHARGING

Every minute the battery voltages are checked. If the voltage has fallen below a threshold level (11.48 V) GEMINI reports the voltage. Once this

level is reached, GEMINI will continue to check the batteries every minute and report to you every five minutes. If the voltage level is critically low (below 10.5 V), the robot issues a warning that, in one minute, it will return to the battery charger. If you are in the midst of an experiment or for some other reason do not want the robot to move, press any key on the keyboard or any function key, except Reset, and GEMINI will stay put.

**IMPORTANT:** In this case, you should either put the robot on the charger, or bring the charger over to the robot, as soon as possible. At this point, the batteries should recharge fully overnight. If voltages fall much below 10.5 V, the potential is increased for "deep discharge"; this will shorten battery lifetime considerably.

A check is also made in the Living Loop to determine if the robot is on its charger. If so, it will connect the motor and logic grounds for charging. The grounds are automatically disconnected when the robot leaves the Living Loop.

Under normal use, GEMINI's batteries should last a year or more. Information on how to detect failing batteries and where to buy replacements is in Section 5 - Maintenance.

#### **THINGS TO DO...PLANNED AND UNEXPECTED**

At a rate too fast for most of us to comprehend (about 1/1000 of a second), GEMINI monitors each user entry port -- keyboard, function keys, voice input, and remote computer. This is in case we have something new for it to do. Otherwise, once every minute a check is made to see if a scheduled task is due to be performed, and, if so, it goes off to do it. Thus, GEMINI emulates, in a primitive way, the daily activities of a person. (Except better--GEMINI rarely speaks

unless spoken to, and always does what it is told!)

If you purchased the optional smoke detector, it is also checked while in the Living Loop. Should GEMINI detect smoke, it will sound the buzzer until the smoke is no longer present.

When GEMINI is in the Living Loop, the following menu appears on the screen:

#### LIFE MENU

- 1-DEMO
- 2-SCHEDULER
- 3-BASIC
- 4-REMOTE
- 5-MONITOR

Using this menu, you can access any of GEMINI's modes, either by the indicated function keys or the keyboard. Also, VOCOL (VOICE CONTROL Language) can be accessed by whistling, making a loud noise, or pressing key "S." To use VOCOL, the robot must first be trained to your voice. Chapter 8 provides details on operation of the optional VOICE COMMAND Language.

Here is a brief description of each of the modes listed in the Life Menu:

1 - DEMO: This menu-driven demonstration program is the same one used by GEMINI when its power is first turned on, minus the initialization and check-out phases. You can sample the robot's talents with the push of a button. This is a good program for showing off GEMINI to friends. For more details on DEMO, refer to Chapter 5 of this manual. This is the only program that does not require a keyboard to set up.

2 - SCHEDULER: This program allows a user, with absolutely no programming experience, to enter scheduled events into the robot. You may use either the on-board keyboard or the optional Remote Communication System computer. Examples of tasks that can be entered are wake-up calls, reminders, home security patrols, operating lights and appliances, playing music, telling stories, reciting poetry, and more. Refer to Chapter 9 for full details on use of SCHEDULER.

3 - BASIC: This high-level language allows the novice or expert to use GEMINI as a standard personal computer, or to write powerful programs commanding the robot's functions. In addition to all the standard BASIC commands, GEMINI BASIC has special functions to allow easy use of all robot sensors and effectors. It also has functions to move the robot to any room in the house, and to move it to the charger station from any room in the house. Complete details on the use of this powerful language are contained in the section on GEMINI BASIC in this volume. BASIC is included in the GEMINI Educational System, and is an option available to other users through ARCTEC SYSTEMS.

4 - REMOTE: The robot communicates with this independent computer system via a radio link. The Remote Communication System (RCS) computer can be controlled directly by the robot, and vice versa. Complete details on installation and operation of this powerful computer are provided in the RCS manual, which is obtained with purchase of the unit.

5 - MONITOR: GEMINI's monitor is an extensive program which acts both as an initial supervisor of and a slave to other programs. It contains its own command language which can be used to alter memory locations, examine programs, control bit ports, and much more. Details on the monitor are found in the TECHNICAL REFERENCE MANUAL.

## OTHER LIVING LOOP OPTIONS

When GEMINI is in the Living Loop, with the LIFE MENU on the screen, a number of useful system tests can be run, each with a single keystroke. Table 7.1 lists the tests and their keystrokes.

TABLE 7.1

### LIVING LOOP SYSTEM TESTS

| TO TEST: |                                | TYPE: |
|----------|--------------------------------|-------|
|          | Voice I/O System               | A     |
|          | Batteries                      | B     |
|          | Read Only Memory Card          | C     |
|          | Random Access Memory           | D     |
|          | Disk or Tape Drive Operation   | E     |
|          | Keyboard                       | F     |
|          | Clock                          | G     |
|          | Propulsion System              | H     |
|          | Bumpers                        | I     |
|          | Sonars                         | J     |
|          | Head                           | K     |
|          | Room Beacon                    | L     |
|          | Door Edge Detector             | M     |
|          | Motion Detector                | N     |
|          | Temperature                    | O     |
|          | Time                           | P     |
|          | Pressure                       | Q     |
|          | Enter Room Table Entry Program | R     |
|          | Enter VOCOL                    | S     |

## CHAPTER 8

### VOICE INPUT/OUTPUT SYSTEM (VIOS)

VIOS is the auxiliary microcomputer which handles the job of voice input, voice output, and sound generation. There are three major user functions in VIOS. These are voice recognition, voice synthesis, and sound synthesis.

The voice recognition function is carried out through the VOICE COMMAND LANGUAGE (VOCOL), and is described here. This program lets you communicate with GEMINI by voice and is included in the GEMINI Educational System. A brief version of VOCOL is included in the DEMO program under the ACROBOTICS option. It is also available from ARCTEC SYSTEMS.

The speech synthesis function employs a text-to-speech algorithm which gives GEMINI the ability to speak in various voices any message which you type on the keyboard. Table 8.1 lists the voice options. The sound synthesis ability lets the user activate "canned" songs and sound effects. Both the speech synthesis and the sound synthesis functions are available through the BASIC and SCHEDULER programs. Descriptions on how to use these features are given in the chapters on those programs. For a complete list of GEMINI's sound and music repertoire refer to Tables 8.2 and 8.3 at the end of this chapter.

### VOICE COMMAND LANGUAGE (VOCOL)

With VOCOL, GEMINI can be commanded by voice to perform many tasks. The state-of-the-art voice recognition system is speaker dependent and language independent. This means that the robot must first be "trained" to a voice and will recognize only one speaker at a time. It

also means that, with proper "training," GEMINI can interpret merci, gracias and danka all as thank you. Try it!

A household frequently will have more than one robot user. Since it would be quite inconvenient to retrain the robot each time a different speaker wished to use voice commands, we have constructed VOCOL so as to allow GEMINI to remember the voice trainings of up to three users.

Once a speaker has trained a particular word group to his/her voice, GEMINI will "remember" that speaker's training and retain it in battery-backed memory, so even when the power is turned off, the vocabulary will not need to be retrained. Later, when the user identifies himself or herself, GEMINI will automatically know which set of trained word groups to use.

Another unique feature of GEMINI's voice recognition system is its adaptive ability. As the robot's voice command function is used, its recognition capability will get better. In other words, through artificial intelligence techniques, GEMINI will "learn" from its successes and mistakes!

### **TRAINING GEMINI**

To use VOCOL for the first time, all of the robot users (up to three) must be present, since GEMINI first needs to be trained to recognize each user's name. The training should be performed in a quiet environment (no radio or TV on!). Each user should pronounce his/her words in a firm, commanding voice. Your best position for voice training is about three feet from the robot. Just follow these steps:



1. To attract GEMINI's attention, whistle or say "GEMINI!" loudly. (VOCOL can also be accessed from the Living Loop by typing key `S`.) If this is the first time anyone has used VOCOL, the robot will say, "TYPE IN NAME OF HUMAN NUMBER 1." When the prompt appears, type your name. After six seconds if no keys have been pressed GEMINI will return to the living mode menu. If this happens, just repeat the steps up to this point. If GEMINI says "NAME IS TOO LONG" try a nickname, but use less than 16 letters.

2. The robot will repeat your name and ask "IS THIS OK?" If the pronunciation is to your liking, type "Y." If you type "N," you will be asked to retype your name. (GEMINI uses phonetics and the rules of English pronunciation; however, as you probably know, there are many exceptions to the rules! If the spelling of your name happens to include one of these exceptions, try misspelling your name to produce the correct pronunciation.)

3. Next, GEMINI will ask "ANY MORE USERS?" If so, type "Y." Two more names can be entered using the same procedure as the first.

4. Now, the robot will ask each user to repeat his/her name several times. As mentioned before, each user should pronounce the words requested in a firm, commanding voice, for best recognition.

**IMPORTANT:** When training or retraining your words, wait until an asterisk (\*) appears on the screen. After this prompt occurs, you may then say your word. (If you do not wait for the prompt, the robot may miss part of your response.)

When this initial phase of the voice training is complete, any of the three users can access VOCOL by voice. This is accomplished by first whistling or making a noise to attract the robot's attention (or by typing "S"). GEMINI will respond with "GEMINI LISTENING." Say your name in a firm voice. GEMINI will say "CONFIRM", and repeat the recognized name. If the robot has identified you correctly, make some sound. If GEMINI hears no response, he will repeat "GEMINI LISTENING", and you can try again.

At this point, in order to make use of the many features of VOCOL, each user must go through several additional vocabulary trainings. However, it is no longer necessary for all three users to be present. Whenever a particular user wishes to access VOCOL, GEMINI will check to see if a vocabulary training is needed for that person. If so, the training will be carried out under the robot's direction.

Each training consists of three phases--an adaptation phase and two training passes through the vocabulary set. The adaptation phase allows the voice recognizer to adapt to the frequency range of the user's voice. When the recognizer has adapted to the voice, it then asks the user to repeat each word in the set twice. During these two passes through the vocabulary, a digital pattern of each word is created and saved by the robot.

Since it would be very tedious (for you--not for GEMINI!) to train all of the vocabulary words at one sitting, VOCOL has been structured so that a particular group of words is not trained until actually needed by that user. Table 8.4 contains a complete list of GEMINI's vocabulary groups. They are described in detail in the next section.

All of the vocabulary trainings are saved in GEMINI's memory, so they should not have to be repeated. If for some reason you wish to repeat or change a vocabulary group, see RETRAINING A WORD GROUP later on in this chapter.

**NOTE:** Sometimes GEMINI will hear a loud noise, think someone is trying to talk to it, and will say "GEMINI LISTENING." When this happens, if no one responds with a name within six seconds, the robot will simply go back to "sleep".

### TALKING TO YOUR ROBOT

Once you have accessed VOCOL and the robot has correctly identified you, a number of modes and functions are available which can be commanded by voice. When developing VOCOL, we realized some means must be provided to ensure that the robot has really understood each command. We, therefore, developed the protocol which GEMINI employs. It works like this. After each voice command or parameter spoken by a user, GEMINI repeats the recognized word. If this word is correct, the user responds with one of the affirmatives--yes, correct, or right. GEMINI will answer "THANK YOU" and then perform the function requested. If the command or word was incorrectly recognized, or you changed your mind, say no, wrong, or negative and try again.

In the examples given below, rather than write all this out each time, the acknowledgment protocol has been indicated with three dots"..." between each command. Remember that you must tell GEMINI, after every command or word, whether it is right or wrong, using the protocol described. This information is processed by the robot's artificial intelligence and allows the word recognition capability to continually improve.

As previously mentioned, when you use a particular mode or function for the first time, the robot checks to see if the necessary vocabulary has been trained to your voice; if not, the robot will direct the training session.

Table 8.4 provides a complete list of GEMINI's vocabulary. Word group 0, trained during the initial training described earlier, contains all the user names. It is the word group used by GEMINI to identify which user is speaking.

The remaining vocabularies are divided into five sets, (numbered 0-4). Each set contains three word groups, one for each user. Sets 0 and 1 are trained by each user, under GEMINI's direction, when he/she first accesses VOCOL. Set 0 contains all the affirmative and negative words recognized by GEMINI. These are used to tell the robot when he is right or wrong in his word recognition.

Set 1 contains the important command words which access each of VOCOL's modes and functions. Once you have entered VOCOL and trained Set 0 and Set 1 vocabularies, a menu of all the Set 1 words is displayed on the screen as a reminder of the voice commands now available to you. (Some of these commands require additional voice trainings. When a command is given, GEMINI determines whether a training is needed and, if so, carries it out. POET, STORY, RETRAIN, JUMP, and BYE require no additional training.)

The command words of Set 1, along with the mode or function which each controls, are described below.

A. **COMMAND** - This accesses GEMINI's Command Mode of operation. In this mode, the robot will respond immediately to a voice command. The list of words recognized in this mode are found in Sets 2 and 3 in Table 8.4. This list must be trained to your voice the first time you access the Command Mode. Some of these are one-word commands, such as "TIME", which causes GEMINI to speak the correct time. Other commands need further parameters. A list of the commands (from Set 2) and their necessary parameters (from Set 3) follows:

**MOVE:** 2 parameters: Direction and number of feet (two digits) to move. If you want GEMINI to move forward eight feet, the command is: "MOVE...FORWARD...ZERO...EIGHT." Other directions are REVERSE, RIGHT and LEFT.

**HEAD:** 2 parameters: Direction and number of steps to turn head. (Each step represents 1.5 degrees.) If you want GEMINI's head to turn right 45 steps, the command is: "HEAD...RIGHT...FOUR...FIVE."

**PAUSE:** 1 parameter: Number of seconds to pause (used in Program Mode).

**RANGE:** 1 parameter: One digit sonar number 0-8. Causes robot to report the range received when the requested sonar is fired.

**ROOM:** 1 parameter: Two digit number indicating room to which you wish robot to move. If you wish GEMINI to move to Room #5 (consult your room chart, Table 6.1), say "ROOM...ZERO...FIVE."

SONG: 1 parameter: number of song (two digits) (see Table 8.3). Robot plays specified song.

SOUND: 1 parameter: number of sound effect (two digits) (see Table 8.2). Robot does specified sound effect.

SPEED: 1 parameter: Number of speed setting, from 0 (slowest) to 9 (fastest).

HOME: No parameters. Causes robot to return to charger.

SCHEDULE: No parameters. This causes the robot to give a list of all events scheduled for the day. (See the chapter on the SCHEDULE program.)

STATUS: No parameters. Robot reports state of battery voltages.

TIME: No parameters. Robot verbally gives the time of day.

NEW: No parameters. (Used in Program Mode to start new program.)

RUN: No parameters. (Used in Program Mode to execute program.)

OPTIONS: Return to the main VOCOL menu.

B. PROGRAM - This command accesses GEMINI's Program Mode of operation. This mode utilizes the same word sets as the command mode, but it allows execution of the commands to be deferred. In other words, in Program Mode you "write" a program for GEMINI using only your voice.

When you have entered this mode (and trained the vocabulary, if not already done), try this:

"MOVE...FORWARD...ZERO...TWO...MOVE...REVERSE...-  
ZERO...TWO...RUN"

This little program should cause the robot to move forward two robot lengths, and then go back to the original position. One small step for robots, one giant leap in man-machine communications!

C. POEM - This command causes GEMINI to use his artificial intelligence to compose five "haiku-type" poems and then recite them for your listening pleasure. (GEMINI sometimes tends to get carried away by its own brilliance!)

D. STORY - The same artificial intelligence is used to tell a "spacey" story -- and we do mean spacey!

E. GAME - This command causes GEMINI to play a number guessing game with you. Briefly, the game is played like this. First, you pick a number between 0 and 99. GEMINI will try to guess it asking each time whether the number guessed is above or below the target number. When it guesses correctly, GEMINI will then pick a number and ask you to guess what it is. Once you have guessed the number correctly, GEMINI will declare a winner based on the number of tries it took before the correct guesses were made.

F. CALC - This command allows you to use GEMINI as a voice calculator. (Vocabulary Set 4 must first be trained to your voice.) The commands available are ADD, SUBTRACT, TIMES, DIVIDE, and EQUALS. Example: To add 2 + 3.5, say:

"TWO...SPACE...ADD...THREE...POINT...FIVE...SPACE...  
EQUALS." GEMINI will tell you the answer.

G. RETRAIN - This command allows you to retrain a single word. GEMINI will ask you to type in the word to be retrained. (For retraining an entire group, see RETRAINING A WORD GROUP in this chapter.)

H. JUMP - This command allows you to run a routine of your own by way of a User Vector. For more information, refer to the TECHNICAL REFERENCE MANUAL, Section 6.

I. BYE - This command causes GEMINI to exit VOCOL and return to the Living Loop.

**IMPORTANT FEATURE:** As mentioned earlier, when using VOCOL, the robot displays a menu on the screen listing the voice commands available at that time. Each command in the menu is numbered. (These are the same numbers shown in Table 8.4.) In addition to voice recognition, GEMINI will also recognize a word if the number corresponding to that word is typed on the keyboard at the appropriate time.

For instance, when you access VOCOL and identify yourself, a menu containing all the Set 1 commands is displayed and GEMINI asks "WHAT IS YOUR PLEASURE?" If at this time you wished to play the guessing game, you could either say "GAME" or type key "4" on the keyboard.

### **RETRAINING A WORD GROUP**

If you should wish to retrain an entire group of words, you must first enter the monitor from the Living Loop, by pressing function key 5 or number 5 on the keyboard. (See Chapter 13 in the REFERENCE MANUAL for more information on the use of the monitor.) Once you are in the monitor, type the following command:



> \$05FX:00

where "X" represents the group number. If group '0' (the names) is to be retrained, then X=0. Otherwise, X=3\* (word set number) + user number. User numbers are 1, 2 or 3, and were assigned during the first training session when you typed in your name for GEMINI to recognize. This command clears the words in that group from memory. The next time you use a word from that group, you will be asked to retrain it.

### HINTS FOR BETTER VOICE RECOGNITION

GEMINI's state-of-the-art voice recognizer has approximately 95-98% recognition accuracy when used under the following ideal conditions:

1. Speech input from a speaker with good diction.
2. Speech input with low background noise (a quiet working area)

Any deviation from these ideal conditions will degrade recognition accuracy.

An extremely important variable in the speech recognition accuracy is the human speaker. In general, you will find that if other people have difficulty understanding you, so will the voice recognizer. It is important that you speak as clearly and consistently as possible. When going through the training session, try to speak each word exactly the same. Here is a list of suggestions:

1. Don't mumble. Speak as though you are commanding a troop of soldiers.
2. Enunciate each vowel in the word carefully.
3. Avoid making extraneous lip and breathing noises when speaking.

4. Retrain difficult words frequently.
5. Try to give commands from approximately the same position you were in during the training session.
6. Try deepening your voice.

Try to select an environment that is relatively quiet when using VOCOL. Avoid areas where other people are talking, refrigerators are humming, another member of the family is banging pots and pans, etc. All of these noises are certainly the sounds of life which future domestic robots must learn to ignore, but GEMINI's system is not yet at that level.

Be patient and experiment.

TABLE 8.1

VOICE OPTIONS

| <u>COMMAND</u> | <u>VOICE DESCRIPTION</u> |
|----------------|--------------------------|
| 0              | Droid                    |
| 1              | GEMINI                   |
| 2              | Villain                  |
| 3              | Child                    |
| 4              | Alien                    |

TABLE 8.2

PROGRAMMABLE CANNED SOUNDS

| <u>SOUND NUMBER</u> | <u>CANNED SOUND</u> |
|---------------------|---------------------|
| 0                   | Clock               |
| 1                   | Moving Robot        |
| 2                   | Gunshot             |
| 3                   | Ocean               |
| 4                   | Silence             |
| 5                   | Train (Choo-Choo)   |
| 6                   | Helicopter          |
| 7                   | Explosion           |
| 8                   | Pump                |
| 9                   | Power Generator     |
| 10                  | Laser               |
| 11                  | Siren               |

TABLE 8.3

MUSICAL SELECTIONS

| <u>SONG NUMBER</u> | <u>SELECTION</u>                              |
|--------------------|---|
| 0                  | Star Spangled Banner                          |
| 1                  | Happy Birthday                                |
| 2                  | Happy Anniversary                             |
| 3                  | Jingle Bells                                  |
| 4                  | Easter Parade (Instrumental)                  |
| 5                  | Auld Lang Syne                                |
| 6                  | When Irish Eyes Are Smiling<br>(Instrumental) |
| 7                  | Star Wars Theme (Instrumental)                |
| 8                  | Robots Are a Man's Best Friend<br>(Original)  |
| 9                  | Music Box Dancer (Instrumental)               |
| 10                 | The Entertainer (Instrumental)                |
| 11                 | Daisy, Daisy                                  |
| 12                 | Raindrops Keep Falling on<br>My Head          |
| 13                 | Havah Nagilah (Instrumental)                  |
| 14                 | O Canada                                      |

ROBOTS ARE A MAN'S BEST FRIEND

A cat or a dog may be quite sentimental,  
But robots are a man's best friend.  
A pet may be cute but it won't be parental  
to your little child, or tell you if the  
weather's mild.  
I can walk, and I can talk when you're away  
then your house I'll defend.  
Give your computer a body and it won't look shoddy.  
Robots are a man's best friend!

**TABLE 8.4**  
**VOCOL WORD GROUPS**

(Word Group 0)

|          |          |          |          |
|----------|----------|----------|----------|
| 0-Name 0 | 3-Name 0 | 6-Name 1 | 9-Name 2 |
| 1-Name 0 | 4-Name 1 | 7-Name 1 | A-Name 2 |
| 2-Name 0 | 5-Name 1 | 8-Name 2 | B-Name 2 |

Set 0 (Word Groups 1,2, and 3)

|           |         |            |
|-----------|---------|------------|
| 0-Yes     | 2-Right | 4-Wrong    |
| 1-Correct | 3-No    | 5-Negative |

Set 1 (Word Groups 4,5, and 6)

|           |         |           |
|-----------|---------|-----------|
| 0-Command | 3-Story | 6-Retrain |
| 1-Program | 4-Game  | 7-Jump    |
| 2-Poem    | 5-Calc  | 8-Bye     |

Set 2 (Word Groups 7,8 and 9)

|         |         |            |           |
|---------|---------|------------|-----------|
| 0-Move  | 4-Room  | 8-Home     | C-New     |
| 1-Head  | 5-Song  | 9-Schedule | D-Run     |
| 2-Pause | 6-Sound | A-Status   | E-Options |
| 3-Range | 7-Speed | B-Time     |           |

Set 3 (Word Groups A,B, and C)

|         |         |         |           |
|---------|---------|---------|-----------|
| 0-Zero  | 4-Four  | 8-Eight | C-Forward |
| 1-One   | 5-Five  | 9-Niner | D-Reverse |
| 2-Two   | 6-Sixes | A-Right | E-Point   |
| 3-Three | 7-Seven | B-Left  | F-Space   |

Set 4 (Word Groups D,E and F)

|         |          |          |         |
|---------|----------|----------|---------|
| 0-Add   | 2-Times  | 4-Equals | 6-Above |
| 1-Minus | 3-Divide | 5-Clear  | 7-Below |

## CHAPTER 9

### SCHEDULER

The SCHEDULER program is accessed by pressing Function Key 2 (or "2" on the keyboard) when the Life Menu is on the screen. This ingenious menu-driven piece of software allows a user with little or no programming experience to assign a multitude of tasks for GEMINI to perform on a timed basis. As you will see when you read on, the sort of tasks to be assigned depends only on your imagination!

When SCHEDULER is first accessed, the following main SCHEDULER MENU appears:

1. ADD ENTRY
2. LIST OR DELETE ENTRY
3. ADD MODULE NAME
4. LIST OR DELETE MODULE NAME
5. ADD ROOM NAME
6. LIST OR DELETE ROOM NAME
7. QUIT?

#### 1. ADD ENTRY

When key 1 on the keyboard is pressed, a list of "missions" is presented:

|            |              |              |
|------------|--------------|--------------|
| A - WAKEUP | B - SECURITY | C - POET     |
| D - STORY  | E - SONG     | F - REMINDER |
| G - BSR    | H - DROID    | I - SENSE    |
| J - MOVE   | K - HOME     | L - BASIC    |
| M - EXIT   |              |              |

Type in the letter of the mission you wish to assign.

A - WAKEUP: This mission assigns the robot the task of moving to the desired room at the time or times indicated to deliver a wakeup message. Upon reaching the specified room, GEMINI announces the current time and rings its chime. It will wait for approximately 30 seconds to hear a sound or to detect motion. If nothing is sensed, it will continue to repeat the time and chime every 30 seconds. Once GEMINI knows you are awake, your typed message will be spoken and a menu will appear with three options:

1. SNOOZE
2. REMINDERS
3. HOME

If you want to sleep 10 more minutes, press Function Key 1. For a list of all reminders in SCHEDULER keyed in for today's date, push Key 2. When you are done, press Function Key 3 and GEMINI will return to its charger. If no keys are pressed within one minute after the menu appears, GEMINI automatically heads for HOME.

**HINT:** Since it takes GEMINI a few minutes to navigate, we suggest you set the time a little ahead of when you actually want to get up. After a few tries, you will know exactly how much of a headstart it will need each morning.

Enter the following information from the keyboard:

Time - Enter in 24 hour format, like this: "1700 (return)". (Don't type the quotes, just the information inside.)

Months - Enter the number or numbers of each month in which you wish the mission performed (i.e., if you want it done in January, February, and March, enter "1,2,3 (return)". You can also enter it as a range of months from 1-3.

Days or Dates - Enter the day or days of the month that you wish the mission performed, separated by commas (i.e., "1,2,7,31 [return]" or "1-2,7,28-31 [return]").

What Room? - Enter the number of the room where you want the mission performed, or its name. (See ADD ROOM NAME below.)

Message - Type in the message you wish GEMINI to deliver.

B - SECURITY: This mission assigns the robot the task of making a programmed security patrol. Control of the RCS computer and most of GEMINI's sensors are available in SECURITY. Information regarding the SECURITY patrol accompanies the optional SECURITY program. It is available through ARCTEC SYSTEMS.

C - POET: This mission assigns the robot the task of reciting five original poems at a particular time and place. The questions are the same as for the WAKEUP mission except that there is no message.

D - STORY: This mission assigns the robot the task of telling an original story at a particular time and place. The questions asked are exactly the same as those for POET.

E - SONG: The robot sings a song at the time and place designated. The questions asked are the same as for POET, except for one additional: SONG # - Consult the list of GEMINI's songs in Table 8.2 for the song number and enter it.



F - REMINDER: This mission allows you to give the robot a reminder message to be said at a particular time or place. It asks for the same questions as WAKEUP. These reminders can also be heard after a WAKEUP by selecting Function Key 2, provided they carry the same date (month and day) as the WAKEUP task.

G - BSR: This refers to the BSR (tm) home control system which comes as part of the optional Remote Communication System (RCS) Computer. It can control lights and appliances, turn on sprinkling systems, control heating systems, and perform other useful tasks. Consult your RCS manual, which comes with purchase of the unit, for BSR setup information. This mission entry requests Time, Months, Days, and also the following:

Module Code or Module Name (See ADD MODULE NAME below) - Refer to your RCS manual for this number.

Module Command - The commands are:

|           |          |
|-----------|----------|
| 1 ALL OFF | 2 ALL ON |
| 3 ON      | 4 OFF    |
| 5 DIM     | 6 BRIGHT |

The command "All On/All Off" turns on/off all modules in the same section as the module given. Options 5 and 6, DIM and BRIGHT, request a level from 1 to 9.

**NOTE:** DIM and BRIGHT commands cannot be used on some appliances such as television sets without serious damage occurring. Please consult the RCS manual.

H - DROID: This mission has to be experienced to be appreciated. Type in the requested information on starting time, stopping time, etc. Then sit back and watch GEMINI take over and do whatever comes to mind -- its mind!

I - SENSE: This mission assigns the task of reporting the state of some of the robot's sensors at a particular time and place. The same information is asked for in POET but, in addition, it lists the name of each sensor, and you must type a "Y" or "N" following each one, depending on whether you want a report of that particular sensor. The sensors available are:

TIME  
TEMPERATURE  
PRESSURE

J - MOVE: A simple mission, used to position the robot in a certain room at a certain time. The questions are the same ones asked for POET.

K - HOME: With the exception of WAKEUP, GEMINI will remain in the designated room upon completion of its task. A scheduled HOME task will send GEMINI back to its charger. Once again, the input is the same as for POET.

L - BASIC: This is a very useful mission. Once scheduled, GEMINI will automatically execute a BASIC program in its memory. The BASIC program must start with line number 10 and end with the EXIT command. First type in (or load from tape or disk) your BASIC program. Then answer all the questions (like POET) regarding time, date and place, and GEMINI will take care of the rest. Use your imagination and have fun!

M - EXIT: Returns you to the main SCHEDULER MENU.

## 2. LIST OR DELETE ENTRY

In this command, three keys are used. The "space bar" will advance the screen to display the next entry. The "D" key will delete the mission currently on the display, and the "RETURN" key will return you to the main SCHEDULER MENU.

## 3. ADD MODULE NAME

Pressing Key 3 on the keyboard allows you to add a module name to the list of BSR modules.

You must enter the following information:

Enter Module Code - Type the module code (from "A01" to "P16"--consult your RCS manual for more details on the numbering system).

Enter Module Name- Type the name desired (i.e., "LIVING ROOM LAMP").

## 4. LIST OR DELETE MODULE NAME

Pressing Key 4 allows you to inspect modules on the list (use space bar), or delete particular names (type `D`). The `Return` Key will again return you to the Main SCHEDULER MENU.

## 5. ADD ROOM NAME

The following information will be requested:

Enter Room Number - Enter FROM 1 TO 15.

Enter Room Name - Type in the desired room name (i.e., "KITCHEN").

## 6. LIST OR DELETE ROOM NAME

Instructions are the same as for Selections 2 and 4.

## 7. QUIT

Pressing Key 7 puts you back into the LIFE MENU.

Although it is fun to have GEMINI talk to you, we understand that sometimes it slows down the process of entering missions. We, therefore, included a command which will turn the speech off. While in the Main SCHEDULER MENU, type a Control-T. To do this, hold down the control key while typing a "T." Release the "T" and then the control key. The speech may be turned back on by typing another Control-T. This is known as a "toggle." The default condition is with the voice on.

To give you some practice using SCHEDULER, try entering a SONG for the robot to play. The words to ROBOTS ARE A MAN'S BEST FRIEND are included in Table 8.3. Set the robot to sing you song # 8 and then follow along. It's one of GEMINI's favorites!

USING BASIC

]

|

)

)

)

**SECTION 4**  
**USING BASIC**

## CHAPTER 10

### INTRODUCTION

In Sections 1-3 you have discovered that GEMINI allows a user with no programming experience the enjoyment of having a fully functional robot. For those users who wish to experiment with a high-level programming language, GEMINI's main computer provides you with the software needed to utilize the BASIC programming language. We call this language GEMINI BASIC.

GEMINI BASIC utilizes many of the functions and commands found on most personal computers. In addition to these commands GEMINI BASIC has special functions which allow use of the robot sensors and effectors. There are also functions available which direct the movement of the robot, whether it be from room to room or back to the charger station.

In the following chapters you will be introduced to the standard BASIC functions and commands, as well as those which are unique to GEMINI. It should be noted that this manual does not attempt to teach you how to program in BASIC. If you are new to BASIC and want to learn, there are a number of good books available to help you.

If you did not purchase GEMINI BASIC, and would like to do so, just fill in the order form and mail it to ARCTEC SYSTEMS. We will ship it right away.

We hope you will have many productive and enjoyable hours programming with GEMINI BASIC. Let us know how you are utilizing GEMINI BASIC and if you have developed programs which you feel would be useful or enjoyable to fellow users.

## CHAPTER 11

### GENERAL INFORMATION

To enter BASIC you must be in the Living Loop. Item number 3 on the LIFE MENU is BASIC. After pressing function Key 3 or key "3" on the keyboard you will see a prompt "]". Now you are ready to begin programming.

### MODES OF OPERATION

In GEMINI BASIC you can enter commands in either the immediate or deferred mode. Commands given directly following the prompt and concluded with a return are immediately executed. For example try typing the following:

```
]PRINT 7 + 2
```

 followed by the return key

GEMINI BASIC will immediately return

9

Commands given in the deferred mode are preceded by a line number. A line number is an integer from 0 to 63999. A sequence of commands is called a "program." Programs are executed by typing the word RUN followed by a return. Each line of the program is executed in numerical order beginning with the lowest line number.

Type the following:

```
]10 PRINT "YOUR NAME"  
]20 GOTO 10  
]RUN
```



As you can see, your name is printed in a continuous line down the screen. This program is an example of an infinite loop and will continue to run until a break is encountered. You can cause a break in the program by holding down the control key and simultaneously pressing the letter C.

Type the following:

```
]10 PRINT 3 + 4  
]20 PRINT 2 * 5
```

Now type RUN and GEMINI BASIC will display:

```
7  
10
```

To see the program you have entered, type

```
]LIST
```

GEMINI BASIC will display the program in sequential order by line number.

If you wish to delete a program line, type the line number followed by a return. For instance type:

```
]10 followed by a return
```

Now type:

```
]LIST
```

GEMINI BASIC will display:

```
20 PRINT 2 * 5
```

You have succeeded in erasing line number 10.

To replace line number 10, retype the line number with the new statement. To insert a line in the program, pick a number between the lines where you wish to insert a new line and type the statement. Increments of 10 or more are suggested to allow for line insertions.

To send the cursor to the uppermost left corner and clear the screen, type

**]CURHOME**

and the screen will be erased.

If you are finished with the current program and wish to begin a new one, type

**]NEW**

This will clear the computer's memory and you can begin to enter a new program.

## **NUMBER FORMAT**

In GEMINI BASIC when a number is printed, only nine digits are shown. Numbers are stored with over nine digits of accuracy but will be displayed with no more than nine digits. Numbers may also have an exponent.

Floating point numbers must be in the range from  $-1*10^{38}$  to  $1*10^{38}$ . Scientific notation is used to print these numbers. The first element will be a (-) for a negative number or nothing when the number is positive. Then a single non-zero number is displayed followed by a decimal point. Following this will be eight numbers followed by an E. After the E the exponent will be displayed. Leading and trailing zeros are not printed.

Integers must be in the range from -32767 to 32767.

## ARITHMETIC OPERATORS

Arithmetic operators are used to perform the usual operations of arithmetic. The following is a list of these operators in order of precedence.

|   |                |                    |
|---|----------------|--------------------|
| ^ | Exponentiation | Example: $2^3 = 8$ |
| * | Multiplication | Example: $4*2 = 8$ |
| / | Division       | Example: $9/3 = 3$ |
| + | Addition       | Example: $5+1 = 6$ |
| - | Subtraction    | Example: $7-4 = 3$ |

## COMPARISONS

The following is a list of available comparisons in GEMINI BASIC. All comparisons have the same precedence.

|    |                                     |                   |       |
|----|-------------------------------------|-------------------|-------|
| =  | EQUAL COMPARISON                    | Example: $(2=2)$  | True  |
| <  | LESS THAN COMPARISON                | Example: $(4<2)$  | False |
| <> | INEQUALITY COMPARISON               | Example: $(2<>2)$ | False |
| >  | GREATER THAN COMPARISON             | Example: $(5>1)$  | True  |
| <= | LESS THAN OR EQUAL TO COMPARISON    | Example: $(5<=5)$ | True  |
| >= | GREATER THAN OR EQUAL TO COMPARISON | Example: $(2>=6)$ | False |

OR - EITHER COMPARISON MUST BE TRUE FOR THE STATEMENT TO BE TRUE.

Example:  $(2=2)$  or  $(3<1)$  True  
 $(2=1)$  or  $(5>8)$  False

AND - BOTH COMPARISONS MUST BE TRUE FOR THE STATEMENT TO BE TRUE.

Example:  $(5<=3)$  and  $(6>1)$  False  
 $(2>1)$  and  $(1=1)$  True

## CONSTANTS

Values executed upon during the use of BASIC are called constants. There are two types of constants: string constants and numeric constants.

String constants are a sequence of alphabetic characters enclosed in quotation marks. For example:

"HELLO"

Numeric constants are positive or negative numbers. A negative number has a prefix (-) in front of it. A positive number is as shown.

-24   negative  
  24   positive

## VARIABLES

Variables are names which are used to represent values in a BASIC program. As with constants, there are two types of variables: string variables and numeric variables. A string variable can only have a character string value. A numeric variable will have a value that is a number.

A variable name must begin with an alphabetic character and may be followed by an alphanumeric character. An alphanumeric character is any letter from A to Z, or any digit from 0 to 9. A variable name can be up to 238 characters long, but only the first two characters are used to distinguish one variable from another. All of the basic commands are reserved words and cannot be used as variable names. A complete list of GEMINI BASIC commands can be found at the end of this section.

String variable names are written with a dollar sign as the last character. For example:

```
A$ = "YOUR NAME"
```

The dollar sign states that the variable will represent a string.

A value can be assigned to a variable by the use of the input statement. For example:

```
]10 INPUT A  
]20 PRINT 5*A
```

Now type **RUN**. GEMINI BASIC will respond with a ?. The question mark is a prompt to the user to input a number. The number that is input will be the value that is assigned to the variable. After the value has been assigned the program will be completed.

```
] ? 4  
20
```

In this case the number 4 was chosen by the user as the value assigned to variable A. The program was then completed and the resulting value displayed. A new value can be chosen by typing and inputting a new value at the question mark.

Integer variables must be followed by a %. For example, I% is an integer variable. These variables have no fractional parts and can have values between -32767 and 32767. Their values can be assigned to floating point variables but the reverse is not true. It will truncate the fractional part and only store the integer value.

For example: A = A% is okay but B% = A is not.

Another method of assigning values to variables is through the use of an assignment statement. For example:

```
]10 A = 5
]20 PRINT 20 / A
]RUN
```

4

Values that have been assigned to variables are stored in the computer's memory and can be erased or changed by one of the following methods.

1. A new line is typed or the old line is deleted.
2. The NEW command is issued.

All numeric variables are automatically assigned the value of zero if not otherwise assigned.

## ARRAYS

An array is a table of numbers which can be referred to in the same manner as a variable. An element of the array is selected by a subscript. The subscript is enclosed with parenthesis and immediately follows the array name. For example:

A(I)

Where A is the array and I is the I'th element of the array.

The element A(I) is only one element in the array. GEMINI BASIC must be told how many elements are in the array A. This is accomplished by the DIM statement.

## DIM A(8)

Here we have stated that there are 9 elements in this array, with 0 being the first subscript. If A(I) is used in a program without being dimensioned

GEMINI BASIC reserves space for 11 elements (subscripts 0 through 10).

## SYSTEM COMMANDS

### SAVE

If you are using a wafer or disk drive with GEMINI you have the advantage of saving your files on disk or wafer tape and not having to retype your programs each time you wish to use them. To save a program you would at the prompt type SAVE and the name you would like to give your program. For example:

]SAVE GEMINI followed by a return

Now type CATALOG and you will see the file that you saved displayed along with any other files which you may have on that wafer or disk.

### LOAD

If you wish to use one of the programs that you have saved on a disk or wafer tape you may do so by typing LOAD followed by the name of the file which you would like to work on. For example:

]LOAD GEMINI followed by a return

This command will load this file into the computer's memory so that you can either execute it or make changes as desired.

### STOP

STOP causes a break in a program and returns control of the computer to the user. The message BREAK IN and the line number where the program ended will be displayed.

## END

END causes a program to break the same as the stop command but does not display a message.

## CONT

The CONT command will restart a program which has been halted by a Control-C or the STOP or END command. The program will resume at the next instruction not necessarily the next line number.

## PEEK (address in decimal)

The PEEK command will display the contents of a memory location in decimal format.

## POKE Address, Contents (both in decimal)

The POKE command stores the binary equivalent of a decimal into the memory location specified.

## CALL address in decimal

The CALL command will initiate execution of a machine-language subroutine at the memory location specified. Call-7165 enters the monitor.



## EDITING COMMANDS

### LIST

The LIST command is used to display lines of a program. LIST followed by a line number, or two line numbers separated by a comma, can be used to display only desired lines. For example:

LIST 10 will display only line 10

LIST 10,100 will display lines 10 through 100

To list a program from the beginning through a specified line type:

LIST -100

To list a program from a specific line through the end of the program type:

LIST 100-

To temporarily halt a listing, depress the space bar. To continue, press the space bar again. To cancel the list command, type a Control -C. The BASIC prompt, ], should appear.

### DEL

The DEL command is used to delete lines of a program. For example:

DEL 10,10 will delete line 10

DEL 10,100 will delete lines 10 through 100

DEL 100, will delete all lines from 100 through the end of the program

## CHAPTER 12

### COMMANDS UNIQUE TO GEMINI BASIC

In addition to BASIC commands that are the same as, or similar to, commands used on the most popular personal computers, GEMINI offers you an incredible array of commands with which you can task the robot and/or get information from its many sensors. The following is a summary of the commands unique to GEMINI. The best way to get acquainted with them is to experiment. You will find many things to do you never dreamed of when you first got your robot!

#### MAKING SOUNDS, PLAYING MUSIC AND SPEAKING

The following commands allow you access to the VIOS computer. To successfully use this computer, it must be enabled and disabled. The following commands are for making sounds, playing music and speaking.

**ENVIOS** - Enables the VIOS computer. This only needs to be done once.

**MKSND N** (N=sound number) - Generates the sound specified by N. See Table 8.3 for a list of available sounds.

**SONG N** (N=song number) - Uses VIOS to play music and sing vocals. Table 8.2 has a complete list of musical selections.

**SPEAK 2\*4, SPEAK "expression"** - Uses the robot's 3rd generation speech chip and text-to-speech algorithm. GEMINI will speak the message within the quotes. Accents (/) and periods for pauses (.) may be helpful to improve the clarity.

**DSVIOS** - Disables the VIOS computer. Be sure to do this before ending program.

#### **DIRECTING GEMINI'S MOVEMENTS**

As in the case with the VIOS computer, the PROCON (PROPulsion CONTroller) computer must be enabled and disabled for BASIC commands. Again, it is only necessary to do this once in a program.

**ENPROP** - Enables the PROCON computer.

**BODY DIR, SPEED, DISTANCE** - Commands robot to go forward or backward if DIR = 1, rotate if DIR = 0. SPEED = 1 - 15, slow to fast. DISTANCE is value of feet in distance or degrees in rotation. DISTANCE is a positive quantity for forward movement or right rotation, and a negative quantity for backward movement or left rotation. DIR, SPEED and DISTANCE can each be a floating point constant, an expression or a variable.

**WAITBOD** - Returns response from BODY command. A 0 means that the command has been completed; else bumper #1-4 is returned. This function must be used after a body command, before giving any other commands to PROCON. However, commands other than those to PROCON may be inserted between BODY and WAITBOD and will be executed. This is a floating point function.

**PAUSE N** - Will cause the robot to pause for N seconds.

**STPBODY** - Commands robot to stop immediately if moving.

**ENBUMP** - Enable bumpers. Bumpers are not enabled in any other commands. DSPROP and STPBODY disable bumpers automatically.

**DSPROP** - Disables the propulsion computer.

## COMMANDING GEMINI'S HEAD

**INITHD** - Initializes the head. This is sometimes a good idea if, for example, you don't know where the head is pointing.

**ROTO N** - Rotate head to absolute position N, where N = 0 - 239. Each increment in N is 1.5 degrees.

**ROT (DIR, STEPS)** - Rotate head the number of STEPS in DIRection specified. DIR = 0 for clockwise rotation. DIR = 1 for counter clockwise rotation. Returns a 0 if no head stop is encountered, or a 1 if a head stop was encountered. This is a floating point function.

**NOTE:** The arguments in the above commands can be any valid BASIC floating point expression. For example:

```
A=5:PAUSE A
VOICE 3+1
```

## GEMINI BASIC STRING FUNCTIONS:

**TIME\$** - Returns the current time in the format HOUR:MIN:SEC on a 24-hour basis as a string. For example, at 09:05:01 a.m., A\$=TIME\$ sets A\$ to "090501".

**DATE\$** - Returns the date in the format MONTH:DAY:YEAR as a string. For example, on October 19, 1985, PRINT DATE\$ would print 101985.

**NOTE:** These strings can be operated on by standard BASIC string functions, e.g., A\$=LEFT\$(TIME\$,1,2).

For more information on string functions, refer to Chapter 13, MORE ON GEMINI BASIC.

## SPECIAL GEMINI BASIC FLOATING POINT FUNCTIONS

**BAT (N)** -Returns voltage level in decimal of battery N,where 0 is the left motor battery, 1 is the right motor battery, and 2 is the logic battery.

**BSR (HC,CC,UC,LC)** - To execute a command through the RCS, the BSR command is available. This will allow you to control lights and other appliances from BASIC. All arguments are floating point numbers. HC = House Code - 0 for A

1 for B  
2 for C  
thru  
15 for P

CC = Command Code - 1 - All Off  
2 - All On  
3 - On  
4 - Off  
5 - Dim  
6 - Brighten

If Command Code is 1 - 2, only give House Code and Command Code. If Command Code is 3 or 4, give UC = Unit Code. If command is to Dim or Brighten, the Level Code is required. LC = Level Code - 0-9. Consult the RCS manual for use of Dim and Brighten commands.

If BSR is done successfully, it returns a 0. If not, it returns a 1.

**CHARG** - Returns 0 if the robot is on the charger, 1 if not.

**LIGHT** - Returns a value from 0-255 for the light level in room.

**MOTION** - Returns 0 if no motion is being detected, and a 1 if motion is being detected.

**NOTE:** All above functions can be used as valid BASIC floating point functions. For example, the following are valid:

```
PRINT LIGHT
A=BAT(0)
C=SOUND+MOVETO (0)
```

**MOVETO(N)** - Move robot to room N. Returns a 0 if accomplished, else returns an error code. (See Table 12.1)

**PRESSURE** - Returns the barometric pressure in millibars.

**PRINT HOME** - Sends the robot back to the charger from any room. Returns a 0 if the robot makes it onto the charger; otherwise returns an error code. (See Table 12.1)

**RANGE(N)** - Returns a range in feet from sonar N. Head sonar = 0, right top front = 1, right bottom front = 2, left top front = 3, left bottom front = 4, right side = 5, left side = 6, front center = 7, back = 8.

**SMOKE** - Returns 0 if no smoke is being detected. However, the bit port for detecting smoke will oscillate when smoke is present. This means the value returned may be a 1 or a 0 when smoke is present. A loop to "poll" the SMOKE detector is used to determine the presence of smoke.

**SOUND** - Returns a sound level value from 0-255.

**TEMP** - Returns the temperature in degrees Celsius.

### TABLE 12.1

ERROR CODES FOR MOVETO AND HOME ARE:

- 1 - Can't find charger beacon.
- 2 - Can't find path to desired room.
- 3 - Can't get room code of adjacent room.
- 4 - Can't find number of doors in room.
- 5 - Lost reflector.
- 6 - Can't get to door.
- 7 - Door is closed.
- 8 - Can't find room beacon of current room.
- 9 - Can't get on charger.

To exit BASIC, type "EXIT." You will be returned to the Living Loop. Even though you are no longer in the BASIC mode, your program will still be available until you either hit the Reset key or write a new program.

## CHAPTER 13

### MORE ABOUT GEMINI BASIC

#### STANDARD BASIC COMMANDS

The following commands, found in most standard BASIC systems, are available on GEMINI:

##### CURHOME

This command clears the screen and puts the cursor in the upper left-hand corner.

##### FOR...NEXT

This is a standard FOR...NEXT loop found in other BASIC languages. Example:

```
  ]10 FOR I=1 to 4  
  ]20 PRINT I  
  ]30 NEXT
```

This program will print 1

2  
3  
4

on the screen. I would = 5 after the program is run.

```
  ]10 FOR I=1 TO 4  
  ]20 FOR J=1 TO 6 STEP 2  
  ]30 PRINT J  
  ]40 NEXT J  
  ]50 NEXT I
```

This program will print 1

3  
5

four times. I would = 5 and J would = 7 after running.



```
]10 FOR A=5 TO 1 STEP - 1
]20 PRINT A
]30 NEXT
```

This program will print 5  
4  
3  
2  
1

and A would = 0 when done. **STEP** is required for decrementing the index and for incrementing other than by 1.

#### GET

This statement gets input and assigns it to a variable similar to the **INPUT** statement. Unlike **INPUT**, **GET** does not wait for a carriage return before assigning. Example:

```
]10 GET A
]20 PRINT A
```

When this program is run, the robot will wait for a key to be pressed. If you press a 2, **GEMINI** will immediately print a 2.

#### GOSUB ... RETURN

**GOSUB** causes execution to begin at the line # specified. Execution continues from this line until a **RETURN** is encountered. After **RETURN**, execution continues with line immediately following the **GOSUB**. Example:

```
]10 GOSUB 30
]15 PRINT "GOODBYE"
]20 END
]30 PRINT "HELLO"
]40 RETURN
```

would cause HELLO  
GOODBYE  
to be printed.

**GOTO** (line number)

This causes program to jump to line # after GOTO.

**IF** (expression) **THEN** statement

If the value of the expression is true, then execute the statement. Otherwise skip it.  
Example:

```
]10 IF 5=5 THEN 30
]15 PRINT "HELLO"
]20 END
]30 PRINT 5
```

When run, this program would cause "5" to be printed. Example:

```
]10 IF (3<4) OR (2<>2) THEN PRINT 2
]20 END
```

When run, this program would cause "2" to be printed. Example:

```
]10 A=1:B=5
]20 IF A=B THEN PRINT B
]30 PRINT A
```

This program would only print the contents of A, since A is not equal to B.

## **IN#X**

This statement changes the input device to the device corresponding to X. Devices are:

- 0 - KEYBOARD
- 1 - PROCON
- 2 - VIOS
- 3 - EXTERNAL PORT
- 4 - EXPANSION 1
- 5 - EXPANSION 2

The keyboard is always available for input. Example: After IN#1, all input will come in from PROCON or the keyboard.

## **INPUT**

This causes the variable after this statement to be assigned the value typed in. This statement gives a ? prompt and continues to read data until a carriage return is typed. Example:

```
]10 INPUT A$  
]20 PRINT A$
```

When this is run, if "HELLO" is typed, execution would look like this:

```
?HELLO  
HELLO
```

A prompt message can be put after the input statement by enclosing it in quotes, and following it with a semicolon and the variable. Example:

```
]10 INPUT "WHAT IS YOUR NAME";A$  
]20 PRINT A$
```

When this is run, the following will happen if you type in FRED:

```
WHAT IS YOUR NAME? FRED
```

```
FRED
```

### **NEW**

This statement clears all BASIC programs and variables from memory.

### **PR#X**

This statement changes the output device to the device corresponding to X. Devices are:

- 0 - SCREEN
- 1 - PROCON
- 2 - VIOS
- 3 - EXTERNAL PORT
- 4 - EXPANSION 1
- 5 - EXPANSION 2
- 6 - PRINTER PORT

### **PRINT**

This causes the value of the expression after the statement to be printed on the screen. More than one expression can be used after one PRINT statement. If these expressions are separated by commas, the display will tab over eight spaces between each value PRINTed. If they are separated by semicolons, all the values are printed together. A semicolon at the end of the last expression will keep a carriage return from being printed after the last value. Examples:

```
PRINT "1,2" would display 1      2
```

```
while
```

**PRINT "1";"2"** would display 12

```
]10 A$ = "HELLO"  
]20 PRINT A$
```

This would display HELLO.

## **READ**

This statement sets the variables after READ to the values pointed to in a DATA statement. Variables after the READ should be separated by commas. Multiple values after DATA should be separated by commas. Example:

```
]10 READ A,B  
]20 DATA 1,10  
]30 PRINT A,B
```

This would display 1            10.

```
]10 READ A$,B$  
]20 DATA "HELLO"  
]30 DATA "GOODBYE"  
]40 PRINT A$,B$
```

This would display HELLO            GOODBYE.

## **REM**

Everything after **REM** on same line as this statement is ignored. This is used to put comments into programs. Example:

```
]10 REM THIS PROGRAM WILL CAUSE HELLO  
      TO BE DISPLAYED ON SCREEN  
]20 PRINT "HELLO"
```

## RESTORE

This statement sets the data pointer to the first value after the first DATA statement. This causes the next READ statement to begin reading data at this statement. Examples:

```
]10 READ A,B
]20 RESTORE
]30 READ C
]40 PRINT A,B,C
]50 DATA 1,2,3
```

This would print 1        2        1.

```
]10 READ A$
]20 READ B$
]30 RESTORE
]40 READ C$
]50 DATA "A"
]60 DATA "B"
]70 DATA "C"
```

This would set A\$ to "A," B\$ to "B," and C\$ to "A."

## RUN

This statement runs a BASIC program. If no line number is given, the program is run from the beginning. Otherwise, it is run from the line # specified. If a name is put after run, the file by this name is loaded from disk or tape and run. Examples:

```
RUN
RUN 10
RUN MYPROG
```

## FLOATING POINT FUNCTIONS

The following standard floating point functions are available in GEMINI BASIC. These functions are used in the same manner as they are in other BASIC languages. They all return floating point values which can be assigned to floating\_point variables. They can also be used to put values into expressions. Examples of legal uses:

```
PRINT SIN(10)    A=SQR(9)    A=5+LOG(2)
```

The arguments in the following functions must be floating point constants, variables or expressions.

**SIN(N)** - Returns the sin of N where N is in radians.

**COS(N)** - Returns the cosine of N where N is in radians.

**TAN(N)** - Returns the tangent of N where N is in radians.

**INT(N)** - Returns the truncated value of floating point number N.

Example: A=INT (5.3) sets A to 5.

**RND(N)** - Returns a random number between 0 and 255.

**ABS(N)** - Returns the absolute value of argument N.

**SQR(N)** - Returns the square root of N.

**EXP(N)** - Returns X raised to N, where X is equal to 2.71828183.

Example: EXP(3) returns 20.0855369.

**LOG(N)** - Returns the logarithm of N.

**ATN(N)** - Returns the arctangent of N.

The following floating point functions use string constants or variables as arguments.

**VAL (A\$)** - Returns the floating point value of the argument where the argument is a number in string form. Example:

```
  ]10 A$="12"  
  ]20 B=VAL (A$)
```

This would set B to 12.

**LEN(A\$)** - Returns the number of characters in argument. Example: A = LEN ("HELLO") would set A to 5.

**ASC(A\$)** - Returns the ASCII code of the first character in an argument string.



## STRING FUNCTIONS

The following functions return strings which must be used in assignments, PRINT or SPEAK statements, or string expressions.

**STR\$(X)** - Returns floating point value X as string.

Example:

```
A$=STR$(12)
```

sets A\$ to "12."

**CHR\$(X)** - Returns character corresponding to ASCII number X.

**LEFT\$(A\$,X)** - Returns the leftmost X number of characters in A\$. Example:

```
PRINT LEFT$("HELLO",2)
```

would display HE.

**RIGHT\$(A\$,X)** - Returns the rightmost X number of characters in A\$. Example:

```
C$=RIGHT$("HELLO",3)
```

would set C\$ to "LLO."

**MID\$(A\$,X,Y)** - Return Y characters starting with the Xth character in A\$. Example:

```
PRINT MID$("HELLO",3,2)
```

would display LL.

## **BASIC ERROR MESSAGES**

Since we are HUMANS instead of ROBOTS, we are prone to make mistakes from time to time. If this happens, BASIC will let you know with an error message. The following is a list of BASIC error messages and what they mean. If the error occurs in deferred mode, the message will be followed by the line #.

**NEXT WITHOUT FOR ERROR** - A NEXT statement was used without a corresponding FOR statement.

**SYNTAX ERROR** - Mistakes exist in spelling of words or format of statement.

**RETURN WITHOUT GOSUB ERROR** - RETURN statement is used without corresponding GOSUB.

**OUT OF DATA ERROR** - READ statement tried to read beyond the DATA statement.

**ILLEGAL QUANTITY ERROR** - A floating point argument was used in a statement which is not a legal quantity for this argument.

**OVERFLOW ERROR** - An overflow has occurred in an arithmetic expression.

**OUT OF MEMORY ERROR** - Program and variable space are too large.

**UNDEF'D STATEMENT ERROR** - A GOTO, GOSUB, or RUN to an undefined line was attempted.

**REDIM'D ARRAY ERROR** - A DIM statement was tried on an array which has already been dimensioned.

**BAD SUBSCRIPT ERROR** - An illegal subscript was used in an array.

DIVISION BY ZERO ERROR - Division by zero was attempted in an expression.

ILLEGAL DIRECT ERROR - A command was tried in the direct mode which can only be done in the deferred mode.

STRING TOO LONG ERROR - Too many characters are in one string.

FORMULA TOO COMPLEX ERROR - Arithmetic expression is too complex.

CAN'T CONTINUE ERROR - A CONT statement was used where there was nothing to continue.

## SAMPLE BASIC PROGRAM

There is no limit to the powerful programs which a person can write for this robot. The following program will allow GEMINI to keep anyone's house quiet. After reading in the number of rooms and the desired sound level in the house, the robot will move to each room and read the sound level. If it is too loud, the robot will tell everyone to get quiet in a very annoying manner until the desired sound level is achieved.

```
]10 REM GET # OF ROOMS IN HOUSE AND DESIRED  
MAXIMUM SOUND LEVEL FOR ALL ROOMS.  
]20 INPUT "HOW MANY ROOMS ARE IN HOUSE";ROOMS  
]30 INPUT "WHAT IS MAXIMUM ALLOWABLE SOUND LEVEL";SND  
]40 REM USE LOOP TO GO TO EACH ROOM  
]50 REM ENABLE VIOS  
]60 ENVIOS  
]70 FOR I=1 TO ROOMS  
]80 IF MOVETO(I)=0 THEN 120  
]90 REM ROBOT CANNOT GET TO THIS ROOM SO SPEAK  
MESSAGE AND TRY NEXT ROOM  
]100 SPEAK "I CANNOT GET TO ROOM":SPEAK I  
]110 GOTO 170  
]120 IF SOUNDS<=SND THEN 170  
]130 REM TELL PEOPLE TO GET QUIET  
]140 SPEAK "EVERYONE PLEASE BE QUIET"  
]150 REM KEEP REPEATING UNTIL IT IS QUIET  
]160 GOTO 120  
]170 NEXT  
]180 REM DISABLE VIOS BEFORE ENDING  
]190 DSVIOS  
]200 END
```

 **MAINTENANCE**

)

)

)

**SECTION 5**  
**MAINTENANCE**

## CHAPTER 14

### HANDLE WITH CARE

Although GEMINI has a tough exterior, its insides are sensitive and need proper care. Establishing general rules to follow will ensure you many hours of enjoyment and education.

#### STATIC

The low power CMOS chips used throughout GEMINI are very sensitive to STATIC. During the cold winter months when the heat is turned on high, this might become a problem. It would be a good idea to use an anti-static spray on the rugs GEMINI will be crossing and around its charger.

Periodically check the static line and mat for proper attachment.

#### HEAD

The blue foam on GEMINI's head is purely for aesthetics. It does not protect the sensor underneath. Please do not POKE anything in the foam as damage to the sensor may result.

#### SONARS

The sonars used on GEMINI are not dangerous. However, you should avoid touching them, especially when they are firing. A clicking sound can be heard as each sonar fires.

#### BASE

When you want to move GEMINI somewhere in a hurry, either pick it up by the handles on the base or use the joystick controller. It is not good for the motors in the base if the

robot is "pushed" around.

## **CHARGER**

As with any electrical appliance, it is a good idea to keep children from playing with the charger. Although it should not hurt them, touching the two brass plates of the charger at the same time could give them a shock.

## **LCD**

The manufacturer suggests that the LCD not be touched. It is also static sensitive and a spark could harm the equipment.

## **LOOSE CONNECTORS**

It is not a good idea to touch any of the boards inside the robot. However, if you need to tighten a loose connector, be sure to touch the aluminum frame with one hand before touching the boards. Also, be sure to check the wiring diagram for the connector if in doubt as to where or how it attaches.

## **EXPERIMENTING**

If you are an experimenter and will be "fiddling" with the electronics, we recommend that you buy a static mat and grounding line for the robot's protection. They are available through ARCTEC SYSTEMS.

## **FOR YOUR PROTECTION**

The smoke detector on GEMINI is intended to be part of an overall security system. It is important that you DO NOT rely on the smoke detector as your only means of detecting a possible fire or hazard.



## CHAPTER 15

### WHAT TO DO IF...

What do I do if GEMINI is doing something and I want to interrupt it?

Simply press the RESET key on the back of the robot.

**REMEMBER:** If GEMINI was running a BASIC program, the RESET button will erase the program from memory.

Things just don't seem to work anymore!

The first thing to do is to press RESET. If the problem persists, check the battery voltages by pressing "B" from the LIFE MENU. Low batteries tend to make the robot appear to be malfunctioning. If the batteries are fine (11.0 or above), try performing a Cold Start.

**IMPORTANT:** Performing a Cold Start has two effects. The first is that all variables are reset to their default conditions. The second is that the VOCOL word groups will need to be retrained. Technically, a Cold Start will only erase the word group training status flags located at \$05F0-05FF. You can retain the training by entering the Monitor and resetting the flags to their original values prior to the Cold Start. If you do not do this, GEMINI will take you through the training passes the next time you enter VOCOL.

To perform a Cold Start:

- 1) Press the RESET Key and hold;
- 2) Press Function Key 5 and hold;
- 3) Release RESET; Release Function Key 5

GEMINI will now perform a complete system check. Refer to your checklist and note any problems. If everything checks out, see if the problem is gone. It might have just needed a "fresh start". If not, call the factory or an authorized service center for help.

Warnings from GEMINI about low batteries are occurring more often.

This is a good indication that GEMINI's batteries are weakening. Under normal conditions the batteries should last about 1 year. Replacement batteries may be obtained through ARCTEC SYSTEMS.

How do I change the batteries?

To change the batteries, first disconnect the base from the torso, by reversing the procedure described in Chapter 3. Remove the battery clamps and then carefully disconnect the battery terminals. **BE CAREFUL** not to touch the terminals together or against the aluminum frame. The sparks could harm GEMINI and scare you! After replacing the batteries connect the terminals, checking to be sure the red wire goes to the plus side of the battery and the black wire to the minus side.

Re-assemble and when powered up, GEMINI will do its system self-check. The battery voltages should be okay, but if not put it on the charger for a while and check back in a few hours.

**HINT:** Enter a reminder for about eight months from today to call ARCTEC SYSTEMS and order GEMINI a set of batteries for next time.

If problems still persist, please call the factory or an authorized service center for help.

We hope you enjoy your new ROBOT FRIEND!

**WARRANTY**

## YOUR ARCTEC SYSTEMS 90-DAY LIMITED WARRANTY

This is a Limited Warranty as defined in the U. S. Consumer Product Warranty and Federal Trade Commission Improvement Act. This warranty gives you specific legal rights, and you may also have other rights that vary from state to state within the United States.

**WARRANTY APPLICABILITY** - This warranty covers only the Arctec Systems assembled GEMINI product and is not extended to other products or components that a customer uses in conjunction with this product. This warranty does not cover software products or damage to products caused by software products. This warranty applies only to the first end-user of the Arctec Systems assembled product who becomes such by purchase at retail. This warranty is not assignable.

**WARRANTY EXCLUSIONS** - This warranty does not extend to installation and adjustment at the User's location, or to a product which has been subjected to misuse, abuse, neglect, accident, improper installation, application, or alteration including but not limited to electrical, mechanical, or cosmetic (including removal of Arctec Systems nameplates, logos, trademarks, or identification), without the expressed written authority of Arctec Systems, or subjected to negligence in use, storage, transportation or handling. CMOS circuitry is extremely sensitive to static electricity, and all CMOS chips are excluded from this warranty.

**SERVICE LABOR** - For a period of 90 days from the effective warranty date, Arctec Systems will pay for service labor by an Arctec Systems approved service facility when needed as a result of defective

workmanship and material in your GEMINI Arctec Systems assembled product.

PARTS - New or rebuilt replacements for factory-defective parts will be supplied for 90 days from the effective Warranty date. Replacement parts are warranted for the remaining portion of the original warranty period.

DAMAGES - Under no circumstances shall Arctec Systems be liable in any way to the user for indirect, special, incidental or consequential damages, including but not limited to, any loss of business or profits, whether or not foreseeable, and whether or not based on breach of warranty, contract, or negligence in connection with the sale of this product. Some states do not allow the exclusion or limitation of incidental or consequential damages, so the above limitation or exclusion may not apply to you.

EFFECTIVE WARRANTY DATE - Warranty begins on the date of purchase at retail by the first end user. For your convenience, keep the dealer's or manufacturer's dated bill of sale or invoice as evidence of the sale. The proof of purchase must be provided when warranty service is requested.

USER'S AND TECHNICAL REFERENCE MANUALS - Read your User's Manual and your Technical Reference Manual carefully so that you will understand the operation and care of your product.

WARRANTY SERVICE - For warranty service, contact your dealer, or any Arctec Systems approved service facility. Parts and service labor that are Arctec Systems' responsibility under this warranty will be provided. Other service and transportation is at the User's Expense.

**APPENDIX**

## LIST OF FIGURES

- FIGURE 3.1 EXTERIOR ABS PLASTIC SHELLS p.13  
FIGURE 4.1 INTERIOR STRUCTURE - FRONT VIEW p.22  
FIGURE 4.2 INTERIOR STRUCTURE - REAR VIEW p.23  
FIGURE 6.1 SAMPLE BEACON AND REFLECTOR p.32

## LIST OF TABLES

- TABLE 6.1 ROOM BEACON ASSIGNMENTS p.35  
TABLE 7.1 LIVING LOOP SYSTEM TESTS p.45  
TABLE 8.1 VOICE OPTIONS p.58  
TABLE 8.2 PROGRAMMABLE CANNED SOUNDS p.58  
TABLE 8.3 MUSICAL SELECTIONS p.59  
TABLE 8.4 VOCOL WORD GROUPS p.60  
TABLE 12.1 ERROR CODES FOR MOVETO AND HOME p.85

## LIST OF PICTURES

- PICTURE 3.1 TORSO/BASE HARNESS CONNECTION p.14  
PICTURE 3.2 PROPER POSITIONING OF BRASS  
HEAD GEAR p.14  
PICTURE 3.3 MAIN COMPUTER SWITCHES p.15