



## Model DA410<sup>TM</sup> VOLUME FLOW ANEMOMETER



### User Manual

## INTRODUCTION

Congratulations on your purchase of a DA410 Digital Anemometer with Volume Calculation! You now own one of the most accurate, reliable, and highly regarded airflow measurement instruments available today.

Pacer's model DA410 digital anemometer is a versatile instrument for measuring air velocity in various applications such as HVAC, aerospace development, industrial process airflow, and fluids research.

Air Volume flow is automatically calculated in units of either cubic feet per minute (ft<sup>3</sup>/min) or cubic meters per hour (m<sup>3</sup>/hr).

The rugged yet precise probes can be used for airstreams that have a wide range of humidity, temperature and contaminants without compromising accuracy.

Features include choice of probe diameters, custom cable lengths, service temperatures up to 212°F (100°C) at the probe, high reliability, and long life.

### Warranty

This product is fully warranted against defective materials and/or workmanship for a period of one year after purchase, provided it was not improperly used. For your protection, please use this product as soon as possible. If returned, it must be securely wrapped, sent prepaid and insured to:

Pacer Instruments, Inc.  
PO Box 726  
60 Dunbar Street  
Keene, New Hampshire 03431  
USA

Please include a note with name, address, telephone number and description of the problem. Although we provide assistance on Pacer products both personally and through our literature, it is still the total responsibility of the customer to determine the suitability of the product for use in their application.

This manual is provided by Pacer Instruments without any kind of warranty. Precautions have been taken in accurately preparing this manual; however, we neither assume responsibility for any omissions or errors that may appear nor assume liability for any damages that result from the use of the products in accordance with the information contained in the manual.

## SECTION 1 - SPECIFICATIONS

### Ranges:

Probe AP275: 40 to 7800 ft/min (feet per minute)  
0.2 to 40.00 m/sec (meters per second)

Probe AP100: 60 to 6800 ft/min  
0.3 to 35.00 m/sec

Calculated Air Volume Flow:  
0.0 to 9999 ft<sup>3</sup>/min (cubic feet per minute)  
0.0 to 9999 m<sup>3</sup>/hr (cubic meters per hour)

**Accuracy:** ±1.0% of reading ±1 digit

**Resolution:** 1 ft/min or 0.01 m/sec  
0.1 ft<sup>3</sup>/min or 0.1 m<sup>3</sup>/hr

**Operating Temperature:**  
Instrument: 32° to 125°F (0° to 50°C)  
Probes: -4° to 212°F (-20° to 100°C)

**Power Supply:** 3 AA alkaline batteries

**Battery Life:** Approx. 150 hours, without backlight

**Battery check:** Automatic low battery display

**Display:** 0.5" LCD, 4 digits, with LED backlight

**Options Available:**

- Protective Boot and Splash-Proof Seal for the Instrument
- USB Communications
- RS232 Communications
- Analog 0-5 Volt Output
- Additional Probes, AP275 or AP100
- Extra extension and/or flexible rods
- Custom cable lengths

**Included:**

- (1) DA410 Instrument
- (1) Vane-type probe head, choice of AP100 or AP275
- (3) Rigid extension rods with handle grip
- (1) Flexible extension rod
- (1) Probe connection cable, 5 ft.
- (3) Size AA 1.5V alkaline batteries
- (1) Hard-shell carrying case with foam liner
- (1) DA410 operation manual

**Dimensions**

**INSTRUMENT**

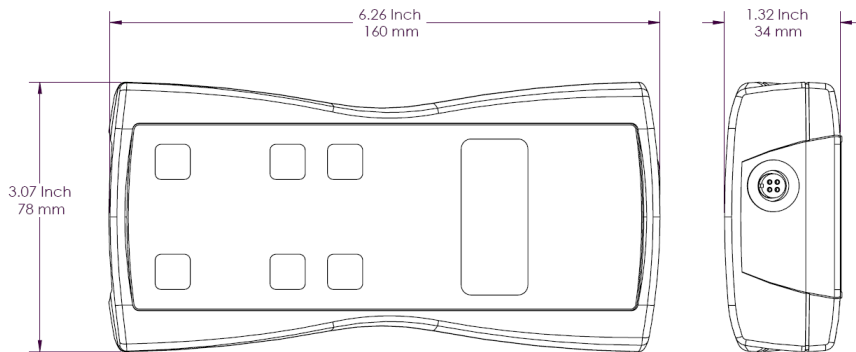

**AP275 PROBE**

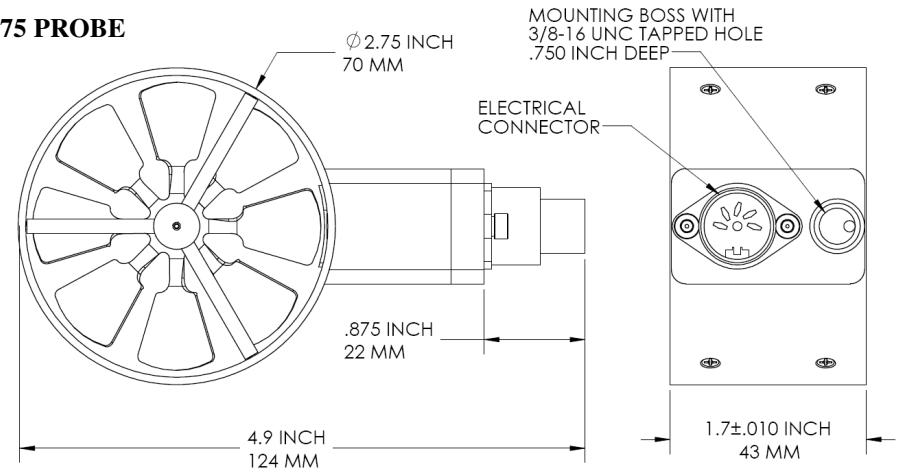

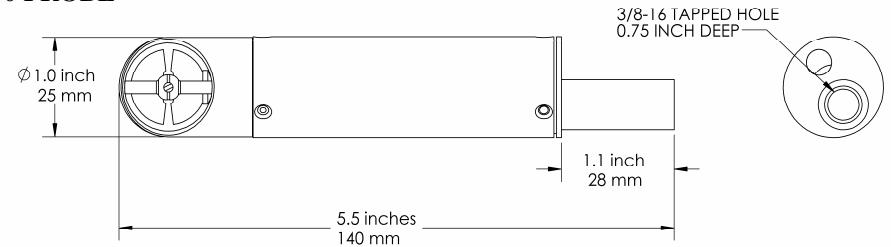

**AP100 PROBE**

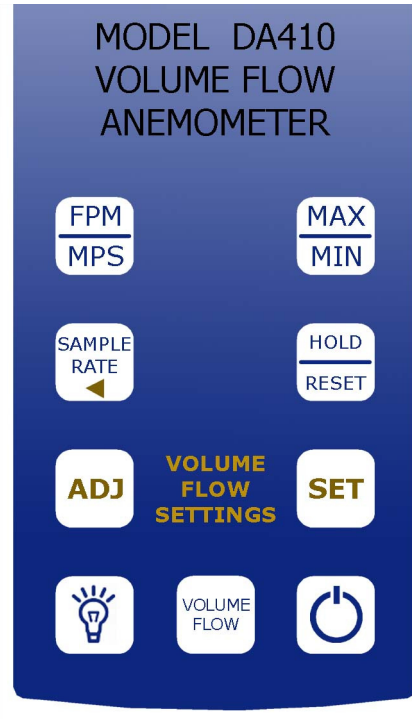

## SECTION 2 – SWITCH FUNCTIONS



 Pressing the ON/OFF key switches the instrument ON. Hold down the key for 2 seconds to switch the unit OFF. The unit will automatically power off after 30 minutes without any key presses. To disable auto power-off, hold down the power button during turn-on. The unit will flash **ADFF**, which means that the auto power-off has been disabled. The auto power-off is re-enabled each time the instrument is turned on.

 Press the BACKLIGHT key to turn the LCD backlight on for 30 seconds. To turn the backlight on permanently, hold the backlight key down for 3 seconds. The LCD will flash. The backlight is now switched on permanently. To switch the backlight off, press the backlight key again.



Press the FPM/MPS key to switch the measurement units from FPM (feet per minute, 1 FPM resolution) to MPS (meters per second, 0.01 MPS resolution). Either **FPM** or **MPS** will be displayed on the LCD.



Press the SAMPLE RATE key to change the measurement averaging rate (“sample rate”) of the unit:

- 2SEC** An average value of airspeed measurements during the preceding 2 seconds is displayed.
- 4SEC** An average value of airspeed measurements during the preceding 4 seconds is displayed.
- 8SEC** An average value of airspeed measurements during the preceding 8 seconds is displayed.
- 16 5** An average value of airspeed measurements during the preceding 16 seconds is displayed.



Press the MAX/MIN key to record and display the maximum airspeed or volume flow reading. The maximum reading display will alternate with the letter “H” displayed with the sample rate. Press the MAX/MIN key again to record and hold the minimum airspeed reading. The minimum airspeed reading display will alternate with the letter “L” displayed with the sample rate. For example:

**1065** alternating with **H 8** signifies that 1065 is the highest reading since the MAX/MIN key was pressed, and the sample rate is set to 8 seconds.

**82** alternating with **L 16** signifies that 82 is the lowest reading since the MAX/MIN key was pressed, and the sample rate is set to 16 seconds.

To exit MAX/MIN mode, press the SAMPLE RATE key.



Press the HOLD/RESET key to freeze the current reading on the display. **HOLD** is displayed on the LCD and the reading is held.

Press the HOLD/RESET key a second time to clear this mode and return the unit to normal operation.

Press the HOLD/RESET key while in MIN/MAX mode to display BOTH the minimum and maximum airspeed reading since the MAX/MIN key was pressed. Once the HOLD/RESET key is pressed while in MAX/MIN mode, new airspeed readings are no longer recorded. To return to MAX/MIN mode, press the HOLD/RESET key again.



Press the “VOLUME FLOW” key to enter Volume Flow mode. Press it again to exit Volume Flow mode and return to Airspeed mode.



While in Volume Flow mode, or Airspeed mode, press “ADJ” to select which Duct setup you’d like to use when in Volume Flow mode. There are 10 Duct setups to choose from and they are shown as *duc0*

through *duc9*.

While in Volume Duct Entry mode, press this key to advance to begin editing a setting, or to adjust a setting, like changing units from *inch* (inches) to *cent* (centimeters), or incrementing a duct size by 1 unit.



While in Volume Flow mode or Airspeed mode, press “SET” to enter Volume Duct Entry mode. This allows you to edit the Duct settings for the currently selected Duct setup.

While in Volume Duct Entry mode, press this key to accept a value. For example, pressing “ADJ” will toggle the units setting between *inch* and *cent*. Pressing “SET” will accept the currently displayed value and advance you to the next menu.



Press the SAMPLE RATE key while adjusting duct sizes to move one digit to the left. This will allow you to go back and adjust the digit you have just set.















Press the HOLD/RESET key at any time while adjusting duct sizes to exit the duct size adjustment. Any changes you have made to duct sizes **are not saved**.

### Duct Size Entry example:

The following example shows how to enter the dimensions of a 12 inch x 12 inch rectangular duct and save this duct at Duct # 4 in memory.

1. Turn the DA410 on.
2. Once turned on, press the “ADJ” key. Continue pressing and releasing until *duc4* is displayed. This now selects Duct setup 4.
3. Press the “SET” key to enter into Volume Duct Entry mode. The display shows *vol* stating that we’re in Volume Duct Entry mode, then shows the Duct setup selection of *duc4*, and then stops at *unit*. Press the “ADJ” key to enter the Units menu.
4. Press and release the “ADJ” key to toggle between *inch* and *cent*. This determines whether the units will be in Inches or Centimeters.
5. Once *inch* has been displayed, press the “SET” key to accept Inches as the Units.
6. The display now shows *duct* stating that we’re now in the Duct Type menu. Press the “ADJ” key to enter the Duct Type menu.
7. Press and release the “ADJ” key to toggle between *rect* and *circ*. This determines whether the Duct type will be a Rectangular duct or a Circular duct.
8. Once *rect* has been displayed, press the “SET” key to accept Rectangular duct as the Duct type.
9. The display now shows *height* stating that we’re now in the Height Entry menu. Press the “ADJ” key to enter the Height Entry menu. The Height can now be edited one digit at a time.

10. To enter in 12.0 inches, press the “SET” key to accept  and move to the cursor to the right, press the “ADJ” Key to increment the current digit to , press the “SET” key to accept  and move to the cursor to the right, press the “ADJ” Key twice to increment the current digit to , press the “SET” key to accept  and move to the cursor to the right, press the “SET” key to accept  and to finish the editing of the Duct Height. *(Note: The blinking digit is the current digit for editing. To increment the current digit, the “ADJ” key can be pressed. To save the current digit and move the cursor to the right, the “SET” key can be pressed. If a digit needs to be edited again, the “SAMPLE RATE/Arrow” key can be pressed to move the cursor to the left again.)*
11. The display now shows  stating that we’re now in the Length Entry menu. Press the “ADJ” key to enter the Length Entry menu. The Length can now be edited one digit at a time.
12. To enter in 12.0 inches, press the “SET” key to accept  and move to the cursor to the right, press the “ADJ” Key to increment the current digit to , press the “SET” key to accept  and move to the cursor to the right, press the “ADJ” Key twice to increment the current digit to , press the “SET” key to accept  and move to the cursor to the right, press the “SET” key to accept  and to finish the editing of the Duct Length.
13. The display now shows *done* which means that we’ve completed the Duct setup and are exiting Volume Duct Entry mode.
14. Now press the “VOLUME FLOW” Key to enter Volume Flow Mode.
15. A 12” x 12” Rectangular duct can now be measured for Volume Flow. *(Note: To get an accurate reading, increase the sample rate to 16 Seconds by pressing the “SAMPLE RATE” key. Then slowly move the air probe around the entire duct opening to get an average reading across the duct opening. This will give a more accurate value for the volume flow rate out of the duct..)*

The following page shows a graphical representation of the steps required to enter the duct dimensions into the DA410.

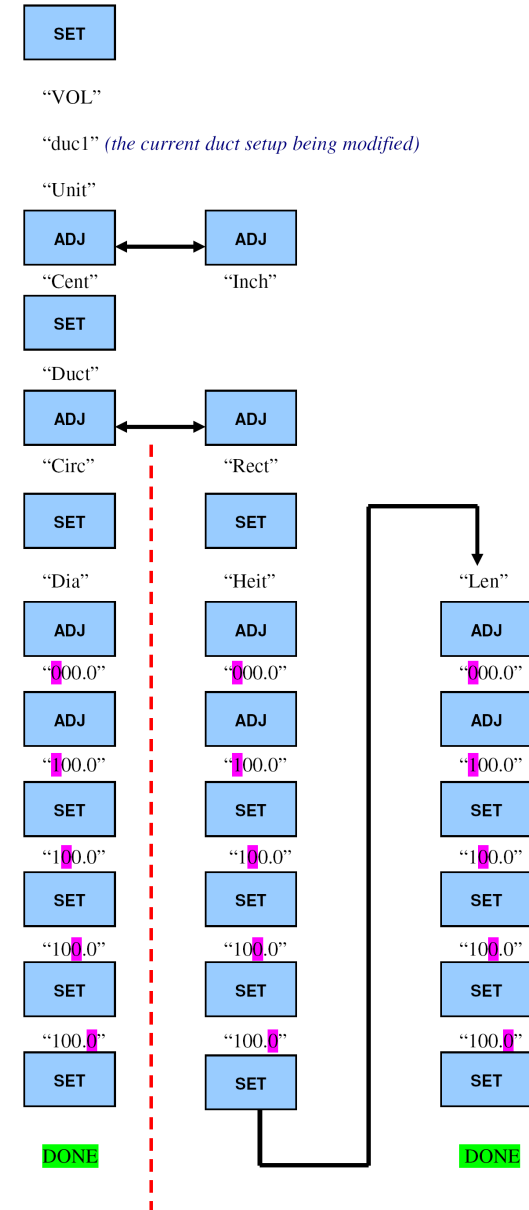



While in Volume Flow Mode, press the FPM/MPS key to switch between units of **cubic feet per minute (CFM)** and **cubic meters per hour (CMH)**. **CUBIC** will be displayed along with either **FPM** or **MPS** on the LCD display to tell you what units you are in.

**Note:** When **CUBIC** and **MPS** are displayed on the LCD display, the reading displayed is in units of **CUBIC METERS PER HOUR**.

## SECTION 3 – OPERATIONAL NOTES

**Caution:** Do not attempt to measure flow from a duct that is smaller than the diameter of the probe head that you are using. This will cause a false reading. Follow the minimum duct cross-section guidelines as detailed below:

AP275 probe (2.75 inch):      Minimum duct width of 2.7 inches (69 cm)  
   Minimum duct height of 2.7 inches (69 cm)  
   Minimum duct diameter of 2.7 inches (69 cm)

AP100 probe (1.0 inch):      Minimum duct width of 1.0 inches (2.7 cm)  
   Minimum duct height of 1.0 inches (2.7 cm)  
   Minimum duct diameter of 1.0 inches (2.7 cm)

**9009 - Out of Range Error:** There are a few circumstances which will cause the instrument to display **9009**, which is the out-of-range error. They are:

1. **Duct dimension is too small:** If one of the user-entered duct dimensions is smaller than the probe diameter as described above, the instrument will display the out-of-range error.
2. **Duct cross-sectional area is too large:** If the cross-sectional area of the duct is too large, the instrument will not be able to display a meaningful result. The out-of-range error will be displayed. The maximum duct cross-sectional areas are as follows:
  - a. 35 ft<sup>2</sup> (3.25 m<sup>2</sup>) when displaying in cubic feet per minute (CFM)
  - b. 20 ft<sup>2</sup> (1.86 m<sup>2</sup>) when displaying in cubic meters per hour (CMH)
3. **Volume flow rate is too high:** If the calculated volumetric flow rate is higher than 9999 cubic feet per minute (CFM) or 9999 cubic meters per hour (CMH) the result cannot be displayed by the instrument. The out-of-range error is displayed.

**APPENDIX A – LCD DISPLAY SYMBOLS**

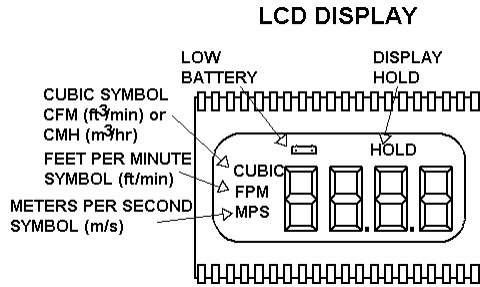

**APPENDIX B – BATTERY REPLACEMENT**

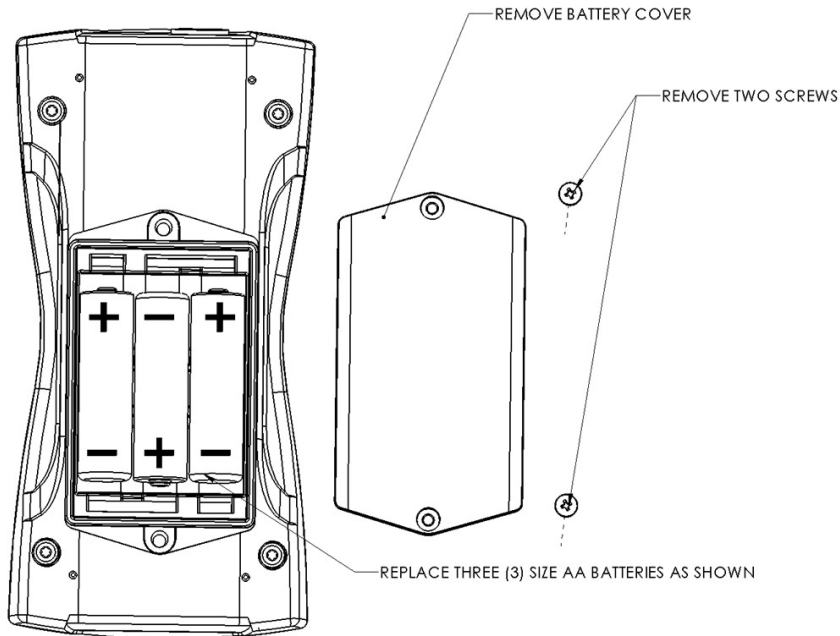

**APPENDIX C – ANALOG VOLTAGE OUTPUTS (IF EQUIPPED)**

If the instrument is equipped with the analog output option, there will be a five-pin connector on the bottom of the instrument. Also, an analog output cable will be included with the instrument. This cable will have a five-pin connector on one end and four tinned wires on the other end.

The instrument will output a Voltage between 0 and 5 Volts that corresponds to the Air Velocity measured by the instrument. The output range, pin assignments, and wire colors are given in the table below. Also shown is a block diagram of the analog output circuit.

Wire Color	Pin #	Function	Analog Output Voltage Range	Corresponding Measurement Range	Equation* to convert from Volts (V) to Measurement Value
BLK	1	Ground	--- N/A ---	--- N/A ---	--- N/A ---
GRN	2	Air Velocity	0 to 5 Volts	0 to 10,000 FPM	Air Velocity = 2000xV
GRY	3	--- Not Used ---	--- N/A ---	--- N/A ---	--- N/A ---
WHT	4	--- Not Used ---	--- N/A ---	--- N/A ---	--- N/A ---

\*To convert from Volts to Air Velocity in Feet per Minute, multiply by 2000.  
 ► For example, an analog output of 2.375 Volts means that the instrument is measuring an air velocity of 4750 feet per minute (FPM).  
 ► 2.375 Volts × 2000 = 4750 FPM

**Note:** When using analog outputs, there is an **additional ±1% error** in the analog output voltage. This is in addition to the normal measurement error.  
 ► For example, an air velocity reading of 500 FPM would normally have an accuracy of ±1% of reading ±1 digit (±6 FPM) when the data is viewed on the LCD display.  
 ► With the additional error associated with the analog output voltage, the effective accuracy of the analog output for this air velocity measurement will be ±2% of reading ±1 digit (±11 FPM).

Custom Analog Voltage Outputs are also available – contact Pacer for details.



Analog Output circuit block diagram and connector pin assignment

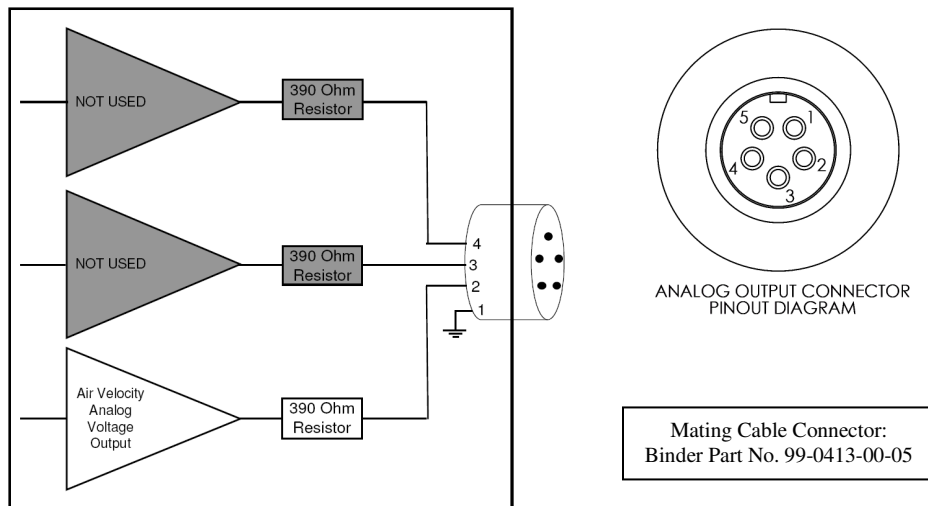

**APPENDIX D - USB DATA OUTPUT (IF EQUIPPED)**

If the instrument is equipped with the USB Communications option, there will be a four pin male connector on the bottom of the instrument. Also, a USB cable will be included with the instrument. This cable will have a four pin female connector on one end and a USB Type-A connector on the other end.

**USB Data Output – Instructions for Use**

STEP 1: Install a Virtual COM Port (VCP) Driver on your computer. Free VCP drivers can be downloaded for Windows, Linux, and MAC from FTDI Ltd on their website: <http://www.ftdichip.com/Drivers/VCP.htm>

We recommend downloading the setup executable, which automatically runs and configures the drivers for you.

STEP 2: Connect the USB cable (included) to the male connector on the bottom of your instrument. Connect the other end to a USB port on your computer.

STEP 3: Turn the Instrument ON.

STEP 4: Verify that the Instrument has been set up as a USB Serial Port with a unique COM port number. (You only need to do this once)

For Windows users, open the Windows Device Manager (found in Control Panel) and verify that a USB serial port exists as shown below.

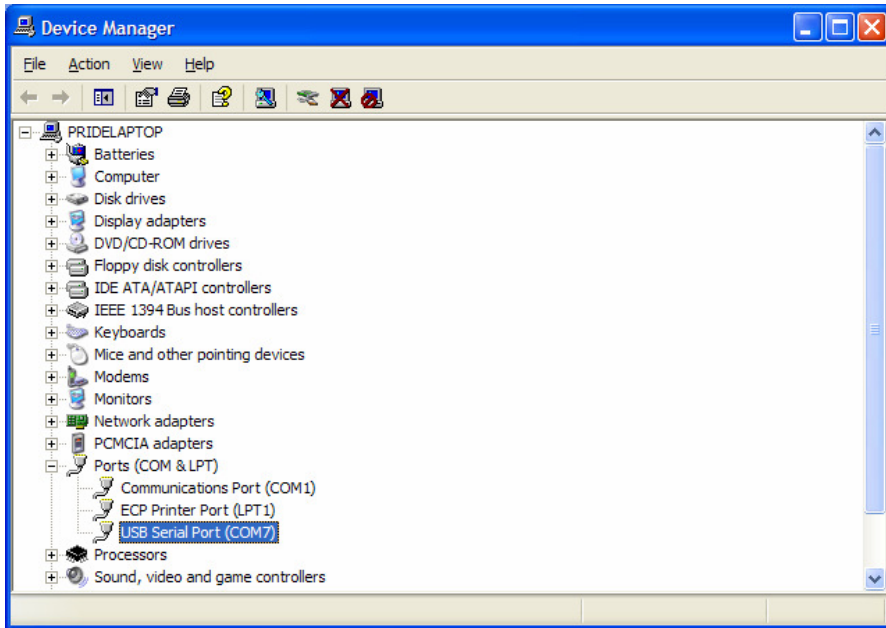

You are now ready to capture the data being measured by your instrument.

Please refer to **Appendix F – Viewing and Capturing Data** for further instructions.

## APPENDIX E – RS232 COMMUNICATIONS (IF EQUIPPED)

If the instrument is equipped with the RS232 Communications option, there will be a three pin male connector on the bottom of the instrument. Also, an RS232 cable will be included with the instrument. This cable will have a three pin female connector on one end and a DB9 Female connector on the other end.

### RS232 Data Output – Instructions for Use

- STEP 1: Connect the RS232 cable (included) to the female connector on the bottom of your instrument. Connect the other end to an RS232 port on your computer.
- STEP 3: Turn the Instrument ON.
- STEP 4: Verify that the Instrument has been set up as a RS232 Serial Port with a unique COM port number. (You only need to do this once). For Windows users, open the Windows Device Manager (found in Control Panel) and verify that a serial port exists.

You are now ready to capture the data being measured by your instrument.

Please refer to **Appendix F – Viewing and Capturing Data** for further instructions.

## APPENDIX F – VIEWING AND CAPTURING DATA (IF EQUIPPED WITH EITHER USB OR RS232 OUTPUTS)

There are many ways to capture the serial port data from the Pacer Instrument. The simplest method is to use a terminal emulator program.

Using a terminal emulator allows the serial COM port to be opened, with the above port settings, and real-time data to be viewed from the instrument. One such terminal emulator program is Windows HyperTerminal.

To launch Windows HyperTerminal, go to:  
START → All Programs → Accessories → Communications → HyperTerminal

Enter a name for the Connection, such as “Pacer DA400” and choose an icon.

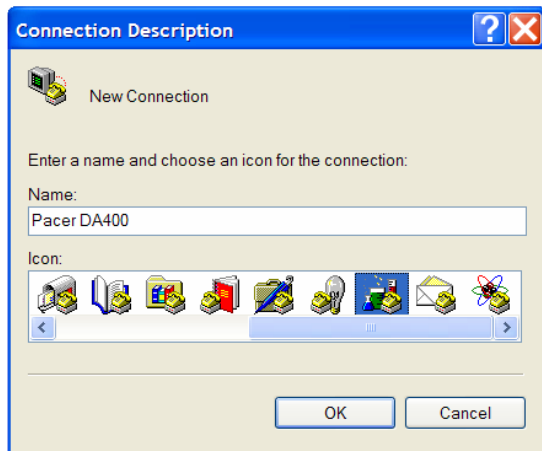

Click OK.

On the next window, next to “Connect using,” select the COM port you that you are using with your instrument. Click OK.



In the next window, select the port settings as shown below and click OK. (The Serial Port settings are also listed at the end of this section).

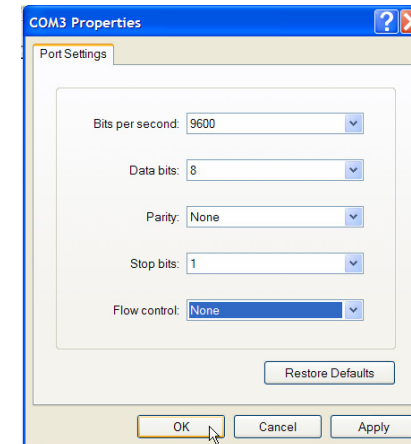

Click on File → Properties. You will see the window shown below. Click on the Settings tab and then click on ASCII Setup... as shown below.

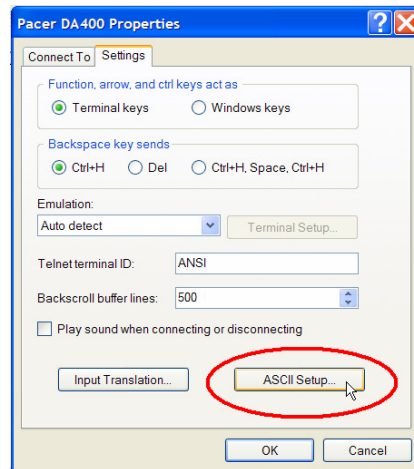

Make sure that "Append line feeds to incoming line ends" is CHECKED as shown below. Click OK.

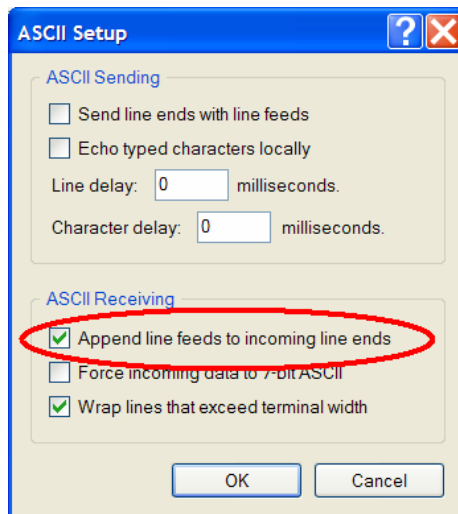

You will now receive data from your instrument. The graphic below shows the serial port output data from Windows HyperTerminal when connected to a Pacer DA400 Instrument.

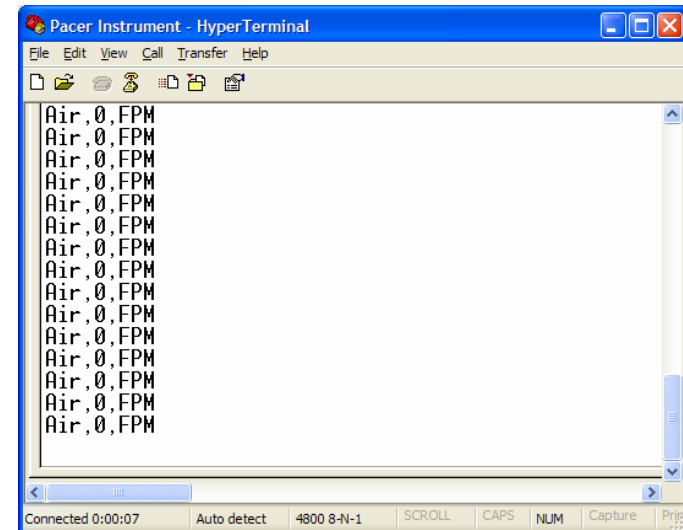

### Serial Port Settings

Bits per Second (Baud)	9600
Data bit	8
Parity	None
Stop bits	1
Flow Control	None

### Serial Port Protocol

Data Output Interval	One Second
Data Format	Comma-Separated Values (CSV)
Measurement Units	Same as Units shown on LCD Display

Below are examples of the formatted output data for Pacer's Premier Series Instruments (units may be different depending on the units selected on the LCD display):

Model DA400:            Air,47,FPM <CR>

Model DA410 displaying in Air Velocity Mode:    Air,47,FPM <CR>  
Model DA410 displaying in Volume Flow Mode:    Air,251,CFM <CR>

Model DA420:            Air,47,FPM,Temp,56.7,C <CR>

Model DA430:            Air,47,FPM,Temp,56.7,C,RH,40.5,% <CR>

Model DH500:            Temp,56.7,C,RH,40.5%,DewP,43.6,C <CR>

### Exporting and Graphing Data

Exporting serial port instrument data from the Pacer Instrument to a spreadsheet application such as Microsoft Excel or OpenOffice Calc allows the data to be graphed or recorded.

The simplest way to export the instrument data is to use a terminal emulator program, like Windows HyperTerminal, and either capture the serial data/text to a file (menu selection) or to manually highlight, copy, and then paste the instrument data into an editor such as Windows Notepad.

Once you have the instrument data in a file, save the file as a .CSV type (e.g., InstrumentData.csv).

Open the file in a spreadsheet application such as Microsoft Excel or OpenOffice Calc. A graph of the data as shown below can now be generated.

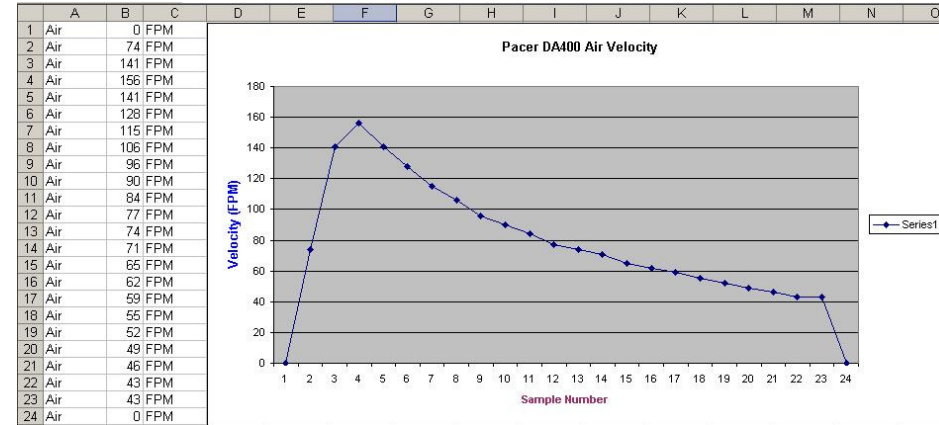

### Duct Dimension Reference Table

The following reference table can be used to record which particular duct dimensions are stored under which Duct Number in your DA410 Anemometer.

Duct #	Length	Height	Diameter	Description
Duct 0				
Duct 1				
Duct 2				
Duct 3				
Duct 4				
Duct 5				
Duct 6				
Duct 7				
Duct 8				
Duct 9				

## CALIBRATION

To maintain your instrument in top working order, we recommend that you send it back to us for calibration each year, beginning one year after purchase.

Our calibration services include ensuring the instrument performs within its accuracy tolerance, making any necessary adjustments, and inspecting all aspects of the instrument's functionality so that you'll have another year of dependable service. Calibration also includes a complimentary firmware upgrade so that you know you'll have the latest advances in accuracy and reliability in your instrument.

NIST-Traceable multi-point calibration is also available from the factory. We can offer precise calibration tailored to your specific measurement needs using our state-of-the-art facilities and calibration equipment.

Please contact us or visit our website for the latest information on calibrating your instrument.



**Pacer Instruments, Inc**  
PO Box 726  
60 Dunbar Street  
Keene, New Hampshire 03431  
USA  
(800) 283-1141  
(603) 352-0187  
Fax: (603) 352-1036  
sales@pacer-instruments.com

[www.pacer-instruments.com](http://www.pacer-instruments.com)

Copyright © 2008, Pacer Instruments, Inc  
Pacer, Pacer Instruments, DA410, AP275, AP100 and the  
Pacer Instruments logo are trademarks of Pacer Instruments, Inc