

# ETC Quick Guide

## Source Four LED Profile



### Overview

For complete information and step-by-step instructions, see *Source Four LED Profile User Manual*.

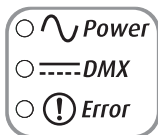
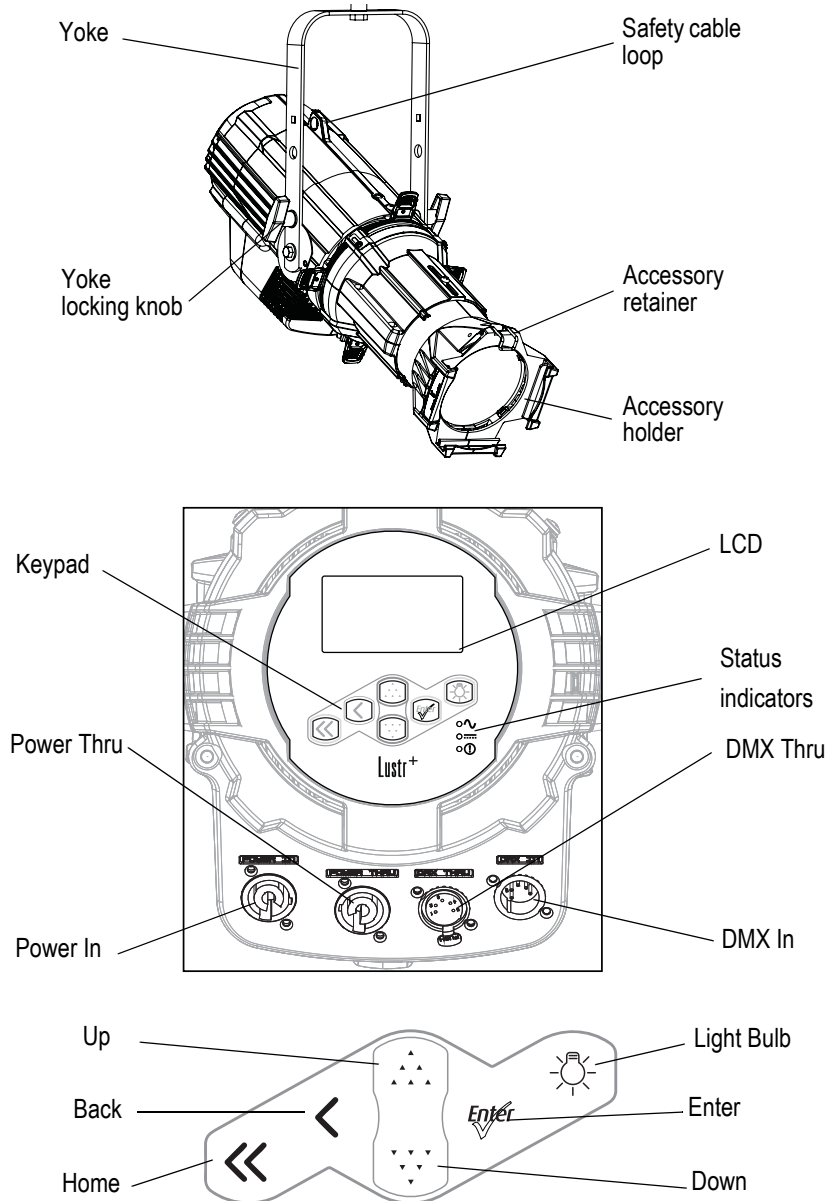

Power – Indicates AC power is On.  
 DMX – Indicates control signal is Active.  
 Error – Indicates data error, high temperature, or other unusual status.

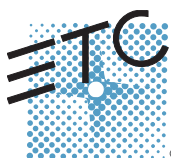

Corporate Headquarters ■ 3031 Pleasant View Road, P.O. Box 620979, Middleton, Wisconsin 53562-0979 USA ■ Tel +608 831 4116 ■ Fax +608 836 1736  
 London, UK ■ Unit 26-28, Victoria Industrial Estate, Victoria Road, London W3 6UU, UK ■ Tel +44 (0)20 8896 1000 ■ Fax +44 (0)20 8896 2000  
 Rome, IT ■ Via Pieve Torina, 48, 00156 Rome, Italy ■ Tel +39 (06) 32 111 683 ■ Fax +44 (0) 20 8752 8486  
 Holzkirchen, DE ■ Ohmstrasse 3, 83607 Holzkirchen, Germany ■ Tel +49 (80 24) 47 00-0 ■ Fax +49 (80 24) 47 00-3 00  
 Hong Kong ■ Rm 1801, 18/F, Tower 1 Phase 1, Enterprise Square, 9 Sheung Yuet Road, Kowloon Bay, Kowloon, Hong Kong ■ Tel +852 2799 1220 ■ Fax +852 2799 9325  
 Service: (Americas) [service@etconnect.com](mailto:service@etconnect.com) ■ (UK) [service@etcurope.com](mailto:service@etcurope.com) ■ (DE) [techserv-hoki@etconnect.com](mailto:techserv-hoki@etconnect.com) ■ (Asia) [service@etcasia.com](mailto:service@etcasia.com)  
 Web: [www.etconnect.com](http://www.etconnect.com) ■ Copyright © 2013 ETC. All Rights Reserved. ■ Product information and specifications subject to change.  
 7460M1300-1.4.0 ■ Rev A ■ Released 2013-03 ■ ETC intends this document to be provided in its entirety.

# ETC Source Four LED Quick Guide

## Install Lens Tube

### Install Lens Tube

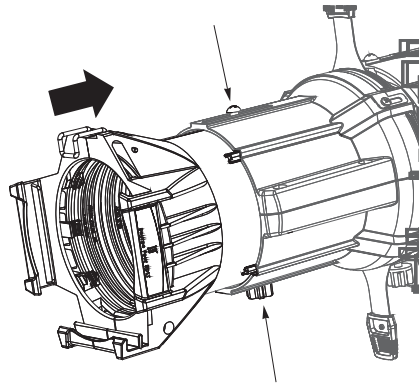

- Step 1: Slide lens tube into shutter barrel.
- Step 2: Install the lens zoom knob.
- Step 3: Install the Phillips screw in the top of the lens barrel.

### Install Fixture

General use position

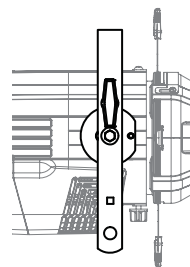
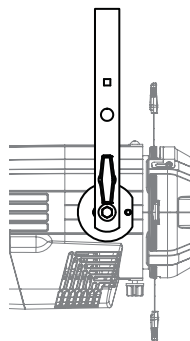

Low clearance position

- Step 1: Hang or mount the fixture.
- Step 2: Attach safety cable.
- Step 3: Insert additional accessories such as a top hat, etc.



**WARNING:** *Use only hardware rated for total weight of fixture and accessories. A safety cable (or other approved safety device) must be securely attached to the safety cable loop before loosening the clamp.*

# ETC Source Four LED Quick Guide

## Connect

### Connect

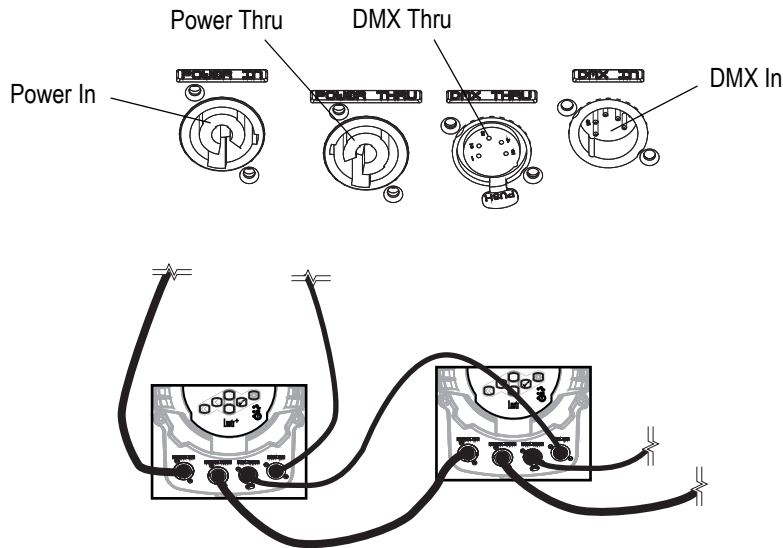

- Step 1: Attach power cable to Power In.
- Step 2: Attach 5-pin XLR cable to DMX In (if using external control).
- Step 3: Connect power cable to AC power.
- Step 4: Plug XLR cable (if using) into data source.
- Step 5: Link additional fixtures via Power Thru and DMX Thru connectors.



**WARNING:** *No more than nine Source Four LED fixtures on Power Thru (non-dimming, 100 to 240 VAC, 50/60 Hz)*

*Up to 32 device loads on the DMX daisy-chain.*

*Disconnect Power and DMX before all cleaning and maintenance.*



**CAUTION:** *The fixture must be connected to a non-dimmable power source in order to avoid damage to its internal power supply and other electrical components. Dimming will damage the fixture and void the warranty.*

# ETC Source Four LED Quick Guide

## Focus

### Focus

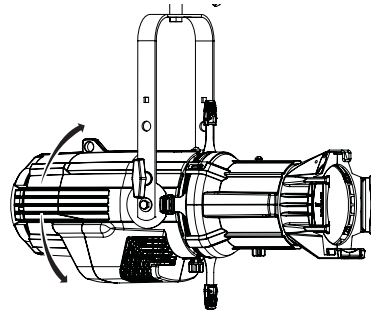
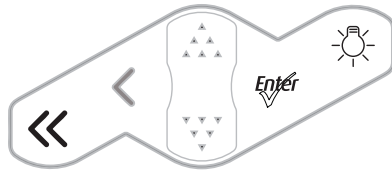

- Step 1: Supply power and wait for the fixture to boot up.
- Step 2: Press **[Light Bulb]** to open **Presets & Sequences**.
- Step 3: Select **Focus** and press **[Enter]** to turn on LED array.
- Step 4: Adjust fixture's position.
- Step 5: Once focus is set, press **[Enter]** to turn off LED array and then **[Home]** to return to home screen.

### Soft Focus Diffuser

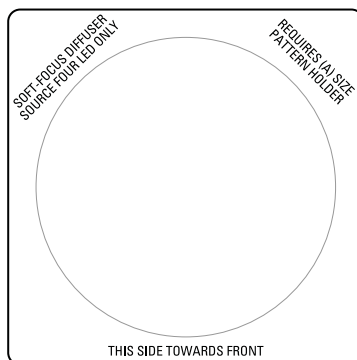

- Step 1: Install the diffuser into an A-Sized Pattern holder.
- Step 2: Install a pattern in front of the diffuser, if needed.
- Step 3: Insert the pattern holder and diffuser into the Pattern holder slot, making sure the writing on the diffuser faces the front of the fixture.

### Address

- Step 1: From the home screen, press **[Enter]** to open **Main Menu**.
- Step 2: On the **Main Menu**, scroll to **DMX Start Address**, press **[Enter]**.
- Step 3: Use **[Up]** or **[Down]** to scroll to desired address.
- Step 4: Press **[Enter]** to select address number.
- Step 5: Press **[Home]** to return to home screen.

\* DMX address is not needed if using standalone or master/slave control.

# ETC Source Four LED Quick Guide

## Features Quick Setup

### Features Quick Setup

- Step 1: On the **Main Menu**, scroll to **Quick Setups**.  
 Step 2: Press **[Enter]**.  
 Step 3: Scroll to the desired setup and then press **[Enter]**.  
 An asterisk (\*) indicates which setup is active.  
 Step 4: Press **[Home]** to return to the home screen.

The top line of the home screen displays the name of the active setup.

Individual features and settings are adjustable under the Advanced menu. Consult the User Manual for more information on advanced features of Source Four LED fixtures.

### Quick Setups

#### Lustr+ and Studio HD

Quick Setup	Features	Recommended For:
<b>General</b>	Smooth dimming, good consistency, direct color control, simple operation.	General lighting, rentals.
<b>Stage</b>	Tungsten-like dimming, HSI color control with Plus-7 fine tuning, fast color mixing and consistency, console output snapshot to record stand alone presets.	Theatrical lighting.
<b>XT Arch</b>	Maximum consistency in extreme applications, reduced brightness.	High-temperature environments, installations with limited access.
<b>High Impact</b>	Maximum brightness, quick response, RGB color control, reduced consistency.	Video-based control, effects lighting, concerts.
<b>Studio</b>	Three-point control—White Point (CCT), Intensity and Tint, DMX, or standalone operation.	Video and film lighting, white light-only applications.

Parameter	General	Stage	XT Arch	High Impact	Studio
<b>DMX Settings</b>					
<b>Profile</b>	Direct	HSI	HSI	RGB	Studio
<b>Strobe</b>	Enabled	Enabled	Enabled	Enabled	Enabled
<b>Data Loss Setting</b>	Instant	Instant	HLL-4ever	Instant	N/A
<b>Plus Seven</b>	N/A	Enabled	Disabled	Disabled	Disabled
<b>Fan Control</b>	DMX	DMX	DMX	DMX	DMX
<b>LED Settings</b>					
<b>Output Setting</b>	Regulated	Regulated	Protected	Boost	Regulated
<b>Dimming Curve</b>	Standard	Incandescent	Standard	Quick	Linear
<b>Red Shift</b>	N/A	Disabled	Disabled	Disabled	N/A
<b>White Point</b>	N/A	3200	3200	5600	N/A
<b>Local Settings</b>					
<b>Status Indicators</b>	On	On	On	On	On
<b>Overtemp</b>	Dark	Dark	Visible	Dark	Visible

# ETC Source Four LED Quick Guide

## Quick Setups

### Tungsten and Daylight

Quick Setup	Features	Recommended For:
<b>Studio</b>	Linear dimming, simple standalone operation via the UI.	Video or film lighting, installations without DMX control.
<b>Stage</b>	Tungsten-like dimming, stage-friendly settings, DMX fan control.	Theatrical lighting, installations mixed with tungsten.
<b>Single Channel</b>	Standard dimming, automatic fan, only 1 DMX channel.	Architectural applications with streamlined control.

Parameter	Studio	Stage	Single Channel
<b>DMX Settings</b>			
<b>Profile</b>	Intensity	Intensity	Intensity
<b>Strobe</b>	Enabled	Enabled	Disabled
<b>Data Loss Setting</b>	N/A	Instant	Instant
<b>Fan Control</b>	DMX	DMX	Automatic
<b>LED Settings</b>			
<b>Output Setting</b>	Regulated	Regulated	Regulated
<b>Dimming Curve</b>	Linear	Incandescent	Standard
<b>Local Settings</b>			
<b>Status Indicators</b>	On	On	On
<b>Overtemp</b>	Visible	Dark	Dark

# ETC Source Four LED Quick Guide

## DMX Profiles

### DMX Profiles

#### Tungsten and Daylight

Channel	Control
1	Intensity
2	Strobe*
3	Fan control*

#### Lustr+ and Studio HD

Channel	HSI	HSIC	RGB	Studio	Direct
1	Hue	Hue	Red	Intensity	Color 1
2	Hue fine	Hue fine	Green	Color temp	Color 2
3	Saturation	Saturation	Blue	Tint	Color 3
4	Intensity	Intensity	N/A	N/A	Color 4
5	Strobe*	Strobe*	Strobe*	Strobe*	Color 5
6	Fan control*	Fan control*	Fan control*	Fan control*	Color 6
7	N/A	Color temp	N/A	N/A	Color 7
8	Plus7 on/off*	Plus7 on/off*	Plus7 on/off*	Plus7 on/off*	Intensity
9	Plus7 - (1)*	Plus7 - (1)*	Plus7 - (1)*	Plus7 - (1)*	Strobe*
10	Plus7 - (2)*	Plus7 - (2)*	Plus7 - (2)*	Plus7 - (2)*	Fan control*
11	Plus7 - (3)*	Plus7 - (3)*	Plus7 - (3)*	Plus7 - (3)*	N/A
12	Plus7 - (4)*	Plus7 - (4)*	Plus7 - (4)*	Plus7 - (4)*	N/A
13	Plus7 - (5)*	Plus7 - (5)*	Plus7 - (5)*	Plus7 - (5)*	N/A
14	Plus7 - (6)*	Plus7 - (6)*	Plus7 - (6)*	Plus7 - (6)*	N/A
15	Plus7 - (7)*	Plus7 - (7)*	Plus7 - (7)*	Plus7 - (7)*	N/A

\* When this feature is enabled.

# ETC Source Four LED Quick Guide

## Typical Power Consumption

---

### Typical Power Consumption

Lustr+

	90V	120V	240V
Idle Power / Current	4.27W / 0.084A	4.38W / 0.079A	4.2W / 0.068A
100% Boost Power / Current	130.8W / 1.48A	129.9W / 1.11A	126.4W / 0.576A

Studio HD

	100V	120V	240V
Idle Power / Current	5.69W / 0.096A	5.71W / 0.091A	5.35W / 0.073A
100% Boost Power / Current	129.2W / 1.3A	127.1W / 1.07A	126.2W / 0.564A

Daylight

	90V	120V	240V
Idle Power / Current	4.3W / 0.083A	4.35W / 0.077A	4.04W / 0.066A
100% Boost Power / Current	165.2W / 1.87A	163.3W / 1.39A	160.3W / 0.718A

Tungsten

	100V	120V	240V
Idle Power / Current	4.3W / 0.085A	4.35W / 0.078A	4.0W / 0.065A
100% Boost Power / Current	159.8W / 1.81A	157.4W / 1.35A	154.8W / 0.695A