

B&B Model 712 **ARMR** Cable Crash Beam Vehicle Barrier

OPERATIONS & MAINTENANCE MANUAL



B&B ARMR

Corporate Office & Technical Support:

2009 Chenault Drive Suite 114

Carrollton, TX 75006

Phone: (800) 367-0387

Fax: (972) 385-9887

E-mail: info@bb-armr.com

techsupport@bb-armr.com

www.bb-armr.com

MADE IN THE USA

INTRODUCTION

Welcome!

Congratulations on your purchase of a B&B ARMR vehicle barrier. In addition to providing detailed operating instructions, this manual describes how to install, maintain, and troubleshoot your vehicle barrier. If you require additional assistance with any aspect of your vehicle barrier's installation or operation, please contact us.

With years of experience in all aspects of perimeter security and related disciplines, our products are used throughout the world to control access and to protect people, equipment, and facilities. We offer a broad range of vehicle barrier and related security services:

- Turnkey installations
- Routine barrier preventative maintenance or emergency repairs (including work on non-B&B ARMR products)
- Spare or replacement parts
- Custom designs or special installations
- Equipment upgrades (modernize your old equipment with state-of-the-art hydraulics and control systems)
- Ancillary security equipment such as security guard enclosures, card readers, security lighting, and many other security related products.
- Technical support via telephone and possible on site support with advanced scheduling.

Safety



SYMBOL MEANING:

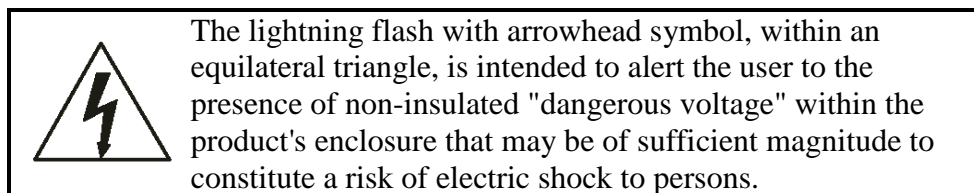



The exclamation point within an equilateral triangle is intended to alert the user to the presence of important operating and maintenance (servicing) instruction in the literature accompanying the product.

B&B ARMR does not assume responsibility for injury to persons or property during installation, operation, or maintenance. As the user, you are responsible for correct and safe installation, operation, and maintenance of this equipment. Users must follow the specific instructions and safety precautions located in this manual. In addition they must: Follow the safety standards of the Occupational Safety and Health Administration (OSHA), as well as other applicable federal, state, and local safety regulations and industry standards and procedures. For installation outside the United States, users must also follow applicable international, regional, and local safety standards. Engage only trained and experienced staff to install, operate, and maintain the equipment. Ensure that all repairs are performed correctly, using properly trained technicians and the correct tools and equipment.

Additional safety devices may be included with this barrier system:

- Vehicle loop detector(s) – Safety loop
- Traffic arms
- Traffic lights

Warranty

B&B ARMR vehicle barriers are guaranteed against defects in materials and workmanship for one year. The warranty applies when the barrier is installed, operated, and maintained according to the instructions in this manual, and when it is operated within the service conditions for which it was specifically sold. The user must prevent potentially damaging conditions, such as mechanical overloading or unauthorized modifications. In the event of a malfunction during the warranty period, contact B&B ARMR and we will pursue prompt corrective action.

This is a warranty summary only. The specific warranty supplied with your equipment is the governing document.

How to Contact Us

If you have any questions or experience any problems with your vehicle barrier, or if we can help you with any other facility security issues, please contact us:

Corporate/Tech Support:

B&B ARMR

2009 Chenault Drive Suite 114

Carrollton, TX 75006 USA

Telephone: (972) 385-7899

Toll Free: (800) 367-0387

Fax: (972) 385-9887

E-mail: info@bb-armr.com

techsupport@bb-armr.com

Table of Contents

INTRODUCTION.....	iv
1. ORIENTATION	7
1.1 <i>Overview</i>	7
1.2 <i>Options</i>	9
1.3 <i>Specifications</i>	9
2. OPERATION	9
2.1 <i>Preliminary Steps</i>	9
2.2 <i>Initial Operation.....</i>	10
2.3 <i>Typical Operation</i>	11
2.4 <i>Barrier Operation during a Power Outage for 712</i>	11
2.5 <i>General Comments on the Hydraulic System.....</i>	12
3. MAINTENANCE	12
3.1 <i>Introduction.....</i>	12
3.2 <i>Monthly Inspections</i>	13
3.3 <i>Six-Month Inspections.....</i>	13
4. TROUBLESHOOTING	15
5. ENGINEERING DRAWINGS.....	17
5.1 <i>Suggested Conduit Layout.....</i>	17
5.2 <i>Clear Opening View.....</i>	18

1. ORIENTATION

1.1 Overview

The formal name for this vehicle barrier—illustrated on the cover of this manual—is the *B&B ARMR Model 712 Cable Crash Beam*. It is a beam-type barrier hinged at one side so that the beam can be raised and lowered to restrict and control vehicle access. The beam is reinforced with an interior steel cable, which significantly increases the barrier's vehicle stopping power (see specifications below).

1.1.1 Beam

The beam is a rectangular aluminum extrusion. The beam retains its mill aluminum finish and is marked with red and white safety tape. The steel cable is contained inside the beam and anchored with two stainless steel rods at either end. These rods hold the cable during vehicle impact. The cable and its anchor rods substantially increase the barrier's stopping power compared to a beam barrier without these components. The impact energy is absorbed first by stretching the cable, and then the energy is transferred to the foundation through the hinge and receiver assemblies.

1.1.2 Posts

The hinge and receiver posts are steel. The hinge post operates with internal bearings on a stainless steel axle that allows the beam to move in an arc of 85°-87°. The receiver post has a stanchion constructed of two steel weldments. The weldments direct and capture the beam when it is lowered, and securely contain the beam during a vehicle impact. The receiver post has a security latching pin that can be padlocked to prevent unauthorized operation when the barrier is unattended (see Figure 1-1 below).

The barrier has a self-contained, exterior-mounted, automatic damping device. When the barrier operates at the design speed, this damper reduces any whipping action by the beam as it comes to the full, raised position.

Figure 1-1: Receiver Post Stanchion and Security Latching Pin

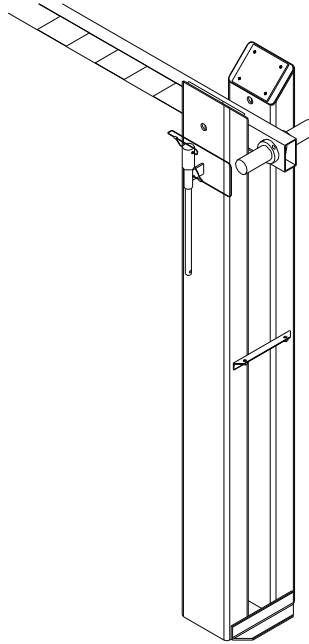

Both the hinge post and receiver post are cast in place in a subterranean concrete pour. Both posts have elevation grade locators to aid the installation. The installation requires no above-grade concrete. The portions of the hinge and receiver posts that are imbedded are coated to prevent deterioration due to cement contact. The aboveground portions of the posts are primed and finish painted in black.

1.1.3 Hydraulic System & Controls

The 712 barrier operates with a complete, self-contained hydraulic unit. It contains not only the hydraulic components, but also the electrical components and a programmable logic controller that is pre-programmed with the barrier's operating logic. The unit has a minimum 1.5 horsepower, 208 / 240-480 volt, three-phase motor. (A single-phase motor is available on special order.) An overload circuit protects the motor in the event of power fluctuations. The control unit is 120-volt, single-phase with 24-volt dc output.

The motor powers a hydraulic pump that delivers oil through a series of valves as directed by the control unit. If the beam is in the up position for extended periods, the control circuit monitors any drift in the beam's position and automatically corrects the position. The unit includes a manual operation override so the beam can be raised and lowered during power outages.

The hydraulic unit is in an aesthetically pleasing round enclosure with built-in environmental controls, including a heater and cooling fan. (An optional heating unit for

extreme winter conditions is available.) The unit has a built-in 120-volt convenience outlet (customer supplies power to outlet) and a master switch turns off all the power to the unit for maintenance and repairs.

1.2 Options

The *B&B ARMR Model 712 Cable Crash Beam* is available with the following options. Consult your purchase order or other ordering documentation to determine whether your unit has the optional equipment.

- Manually operated hydraulic unit (these units are designated as Model 714)
- Single-phase hydraulic pump motor
- Hydraulic unit heater for extreme cold weather operation
- Various control panel options (touch screen panels, multiple panels, and so on)
- In-ground loop detector to detect the presence of a vehicle and prevent accidental lowering of the beam onto the vehicle
- Traffic lights (red and amber stop/go lights to signal the vehicle)
- Lights (LEDs) on the beam to increase the beam's visibility
- Receiver post heater
- Electromagnetic Lock

1.3 Specifications

Key specifications for the *B&B ARMR Model 712 Cable Crash Beam* are as follows.

- Meets or exceeds US Navy Specification OR098-09-88
- Certified vehicle-stopping power is 10,000 pounds at 18 mph.

2. OPERATION

2.1 Preliminary Steps

Before operating the barrier, go through the checklist below and verify that each of these steps has been completed.



For your safety, complete each of these steps before operating the barrier!

- The master power switch on the control circuit box is turned off.
- All traffic and pedestrians are clear of the barrier.
- The hydraulic pump unit is filled with oil and the oil level is correct.
- The beam is attached to the hinge post with the axle, and the setscrews securing the axle to the bearings are tight.

- The hydraulic cylinder is securely attached to the hinge post and the beam with clevis pins.
- If the barrier has a three-phase motor, verify that the motor is turning in the proper direction.
- Bleed the hydraulic lines (refer to the HPU user manual supplied with the unit).

2.2 Initial Operation

Perform the following steps the first time you operate the vehicle barrier, and also after replacing the hydraulic oil or after any major repairs.

- 2.2.1** Turn on the power at the master power switch located on the control circuit box. Have someone remain at the power switch during the initial operation in case there is a malfunction and the unit must be shut down.
- 2.2.2** Working from the control panel, raise the beam arm. (The procedure for doing this will vary depending on the design of your particular control panel.)
- 2.2.3** Carefully observe the beam and make sure it is operating correctly. The arm will stop when the beam contacts the limit switch or if the control unit times out. The beam arm motion may not be smooth for the first several operations due to air in the hydraulic lines.
- 2.2.4** If necessary, adjust the limit switch so the switch activates and the beam arm stops at the correct position.
- 2.2.5** Turn on the power at the master power switch located on the control circuit box. Have someone remain at the power switch during the initial operation in case there is a malfunction and the unit must be shut down.
- 2.2.6** Working from the control panel, raise the beam arm. (The procedure for doing this will vary depending on the design of your particular control panel.)

- 2.2.7** Turn on the power at the master power switch located on the control circuit box. Have someone remain at the power switch during the initial operation in case there is a malfunction and the unit must be shut down.
- 2.2.8** Working from the control panel, raise the beam arm. (The procedure for doing this will vary depending on the design of your particular control panel.)
- 2.2.9** Carefully observe the beam and make sure it is operating correctly. The arm will stop when the beam contacts the limit switch or if the control unit times out. The beam arm motion may not be smooth for the first several operations due to air in the hydraulic lines.
- 2.2.10** If necessary, adjust the limit switch so the switch activates and the beam arm stops at the correct position.
- 2.2.11** Make sure the beam arm stops smoothly in the up position and there is minimal oscillation or whipping action. If necessary, adjust the position of the damping plunger by screwing it in or out. The plunger must strike the beam while the beam is still in motion, but the plunger must not bottom out when the beam arm is fully up. After adjustment, lock the position of the damping plunger by tightening the lock nut.
- 2.2.12** Make sure the beam arm stops smoothly in the receiver post and does not oscillate, contact hard, or make excessive noise.
- 2.2.13** You can adjust the up and down speed of the beam arm by turning the speed control valves (refer to the HPU user manual for location). For the nominal 12' beam arm, the beam will rise and fall in 8-10 seconds. Longer arms can take up to 20 seconds.
- 2.2.14** The hydraulic pump is adjusted at the factory for typical operating conditions. To obtain optimum performance of your barrier, you may have to make a field adjustment to the pump's pressure relief valve, (refer to the HPU user manual supplied with the unit).

2.3 Typical Operation

The system receives an OPEN input signal, typically from the barrier up button, a card reader, a loop detector, infrared beam, or a radio remote. The motor then starts and the beam arm begins to lift. When the beam arm reaches its full up position (less than 20 seconds) the limit switch is activated and the motor turns off.

The beam arm holds this position until a CLOSE input signal is received. The hold cartridge valve is then energized and opens causing the beam arm to lower. After 30 seconds the valve will de-energize and close.

2.4 Barrier Operation during a Power Outage for 712

You can raise and lower the beam arm manually during a power outage as follows for the 6120 HPU, for any other HPU reference that user manual.

- 3.4.1 Turn the power switch to the OFF position (in case the power is suddenly restored).
- 3.4.2 Place the provided speed wrench on the screw head located on the top of the electric motor and turn it in the direction of the arrow. This drives the hydraulic pump and raises the beam arm.
- 3.4.3 To speed up raising the beam arm you can drive the screw head on the motor with a cordless drill and socket.

NOTE: Do not turn or spin the motor in the reverse direction, as this will damage the hydraulic pump!

- 3.4.4 To lower the beam arm, use the electric valve with the blue/red knob that is located on the front of the pump below the motor and above the reservoir. To lower the beam arm, push in the **blue/red knob** and turn it counterclockwise. This action must be reversed to operate in normal condition. When the beam is in the down position push the **blue/red knob** and turn clockwise, this will position the electrical valve in the normal position.

2.5 General Comments on the Hydraulic System

The hydraulic unit for the *B&B ARMR Model 712 Cable Crash Beam* is called a *Model 6120 Hydraulic Pumping Unit*. It is designed to operate for long periods with very little maintenance. It is a single-acting system that operates at relatively low-pressure and low-flow. The electric motor operates the gear-type hydraulic pump, which only operates on a command signal. Hydraulic oil is drawn through a filter and into the speed control valves. A cartridge valve controlled by the operating logic controls the barrier beam's position.

3. MAINTENANCE



Do not attempt repairs unless you are trained and qualified. This vehicle barrier can cause equipment damage and severe injury if it is operated or maintained improperly.

3.1 Introduction

The *B&B ARMR Model 712 Cable Crash Beam* is designed to be largely maintenance free. As with any complex electromechanical device however, it must be regularly inspected to ensure it is operating correctly. We recommend a simple monthly visual inspection and a more thorough biannual inspection as described below. Also described below is the procedure for draining and changing the hydraulic oil, should this ever be required.

Remember, you may contact B&B ARMR for assistance with inspections, maintenance, or repairs.

Component damage is likely if a vehicle strikes the barrier. If an impact occurs, contact B&B ARMR. We will help you assess the damage and make sure there is no hidden damage that will compromise safety or effectiveness. We will help you determine which components should be replaced, and will provide guidance on the repairs.

3.2 Monthly Inspections

We recommend you perform the following visual inspections monthly.

- 4.2.1 Raise and lower the barrier and observe its motion. Verify the speed is within the normal range (8-10 seconds rise time for the standard 12' beam, proportionally longer for longer beams). Verify the beam does not hit with excessive force when lowered. To adjust the speed, see the instructions in section 3.2.7 in the *Operation* section of this manual.
- 4.2.2 Raise and lower the barrier and observe its motion. Verify the damping device is working properly and there is minimal whipping or oscillating action as the beam stops in its raised position. If the damping device requires adjustment, see the instructions in section 3.2.5 in the *Operation* section of this manual. The damping cylinder is sealed, so if the adjustment procedure does not eliminate the problem, contact B&B ARMR for a replacement.
- 4.2.3 Raise and lower the barrier and observe the alignment of the arm. Adjust as necessary.
- 4.2.4 Raise and lower the barrier and observe the limit switch operation. Verify the limit switches are functioning.
- 4.2.5 Raise and lower the barrier and activate the safety devices and verify correct operation.
- 4.2.6 Inspect the condition of the paint. If rust is present, wire brush and sand the area then paint with a primer and the matching color.
- 4.2.7 Inspect the nylon pads on the beam arm and the receiver post for damage or excessive wear. Replace the individual pads as necessary.
- 4.2.8 Inspect the bushing within the arm, note abnormal wear, grease and replace as needed.

3.3 Six-Month Inspections

We recommend you perform the following inspections every six months.

- 4.3.1 Repeat the visual inspections in steps 4.2.1 through 4.2.8 above.

- 4.3.2 Inspect the brushes that protect the hinge-side of the vehicle barrier. If they are worn to the point they have lost their function they should be replaced. The original brushes are held by rivets, which will have to be removed.
- 4.3.3 Turn the master power switch on the control circuit box to the **OFF** position.
- 4.3.4 Through the top of the hinge post, access the pillow block bearings that hold the stainless steel axle. Grease these bearings through their zerk fittings using a high quality, multi-purpose bearing grease.
- 4.3.5 Setscrews on the bearings hold the stainless steel axle in place. Verify these setscrews are tight.
- 4.3.6 Inspect the clevis pins holding the hydraulic cylinder that raises and lowers the beam. Lubricate the pins with high-quality, multi-purpose bearing grease. If the clevis pins show signs of wear, replace them. The clevis mountings have bronze bushings pressed into the steel housing. These bushings can also be replaced if they show signs of excessive wear.
- 4.3.7 Inspect the hydraulic unit for signs of oil leaks. Check the hoses for wear or abrasion. Check all fittings for tightness. Inspect the oil level by opening the tank; the level should be 5" – 6" below the top of the tank. Add oil as necessary. We recommend using environmentally safe oil such as Mobil EAL 224.

Safety Note: If you replace a hydraulic hose you must make sure the pressure has been relieved before disconnecting the hose fittings. To do this you must turn the power back on and activate the down control on the control panel. Verify that the hydraulic cylinder retracts completely. If it does not fully retract, the hose is still under pressure and must not be serviced. You can manually relieve the pressure by releasing the cartridge valve and verifying that the cylinder moves to its fully retracted position. Turn the power back off before continuing.

- 4.3.8 Open the hydraulic oil tank and inspect the oil for dirt or water. If oil replacement is necessary, see section 4.4 below.
- 4.3.9 When the inspection is complete, turn the master power switch on the control circuit box to the ON position.

Safety Note: After any major repairs, repeat the *Preliminary Steps* (see section 3.1) and the *Initial Operation* sequence (see section 3.2) before returning the barrier to service.

4. TROUBLESHOOTING

The table below provides guidance on identifying and correcting any problems with your *B&B ARMR Model 712 Cable Crash Beam* vehicle barrier. If you encounter problems that you cannot fix, contact B&B ARMR and we will gladly work with you to correct them.

Model 712 Troubleshooting Guide

Symptom	Actions
Beam arm does not go up	<ol style="list-style-type: none"> 1. Check power 2. Check overload protector 3. Check PLC input 4. Check that safeties are clear 5. Check PLC output 6. Check push button operation
Beam arm does not go down	<ol style="list-style-type: none"> 1. Check power 2. Check overload protector 3. Check PLC input 4. Check that safeties are clear 5. Remove manual clock 6. Check cartridge valve operation 7. Check PLC output 8. Check push button operation
Beam arm whips excessively	<ol style="list-style-type: none"> 1. Check limit switch adjustment 2. Check that dampening piston works and is adjusted properly
Beam arm makes noise	<ol style="list-style-type: none"> 1. Check that bearings are greased 2. Check that beam arm is not moving too fast
Unit is excessively hot	<ol style="list-style-type: none"> 1. Check that cooling fan is working 2. Check that the cover is on properly 3. Check that the limit switch is turning the motor off (not time)

Symptom	Actions
	4. Check the heater element
Beam arm moves slowly	1. Check that heater element is working 2. Check flow control valve
Traffic indicator light does not change	1. Check proper limit switch operation 2. Check bulbs 3. Check PLC outputs
Beam arm strikes receiver post	6. Check that strike pads are present 7. Check that hinge and receiver post are aligned correctly

5. ENGINEERING DRAWINGS

5.1 Suggested Conduit Layout

REFERENCE DESIGNATOR	DEVICE	NUMBER OF WIRES	WIRE GAGE	POWER VOLTAGE
A	2" HYDRAULIC CONDUIT	-	-	-
B	LIMIT SWITCH	2	14	24VDC
C	OPTIONAL HEATER	2	14	120VAC
D	OPTIONAL MAG-LOCK	2	14	120VDC

- NOTES:
- 712 HINGE & RECEIVER POST FOUNDATION, 36" SQUARE, 4000 PSI, #6 SCREEN, 4 SIDES.
 - PLACE PUMP TO ACCOMMODATE 2" CONDUIT SWEEP MINIMUM RECOMMENDED DISTANCE GREATER THAN 4", LESS THAN 50".
 - 6120 HPIV FOUNDATION: 22" SQUARE MIN. x 6" DEEP, 6" SLEEVE FOR CONDUITS.
 - THE CONCRETE SHALL DEVELOP A MINIMUM COMPRESSIVE STRENGTH OF 4000 PSI. THE MAXIMUM AGGREGATE SIZE SHALL BE 1 INCH, PER ASTM C1450.
 - THE FOUNDATION SHALL BE POURED ON UNDISTURBED SOILS. STANDING WATER IN THE EXCAVATION SHALL BE REMOVED PRIOR TO POURING THE FOUNDATION.
 - THE FOUNDATION DIMENSIONS SHOWN (36" x 36" x 48" DEEP) ARE CONSIDERED MINIMUM.
 - FOUNDATION SIZE IS BASED ON MINIMUM ALLOWABLE SOIL BEARING CAPACITY OF 1,600 PSI.

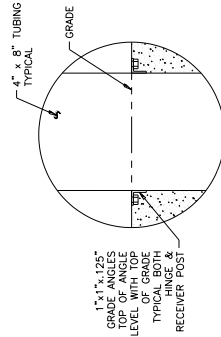
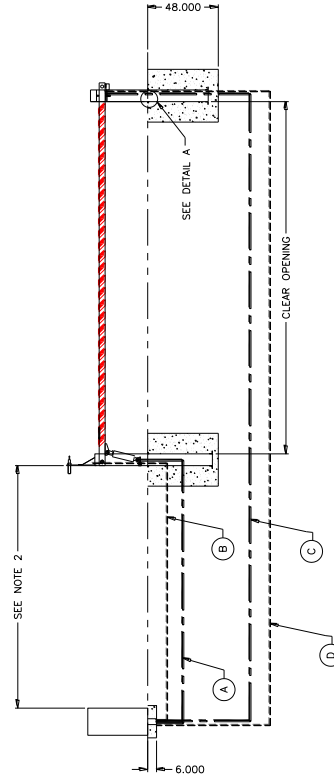
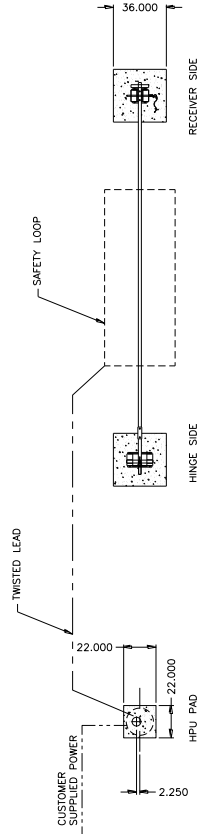

712 CONDUIT LAYOUT
 712 CABLE CRASH BEAM
 SUGGESTED CONDUIT LAYOUT

B&B ARMOR
 2005 General
 800-357-0387

5.2 Clear Opening View

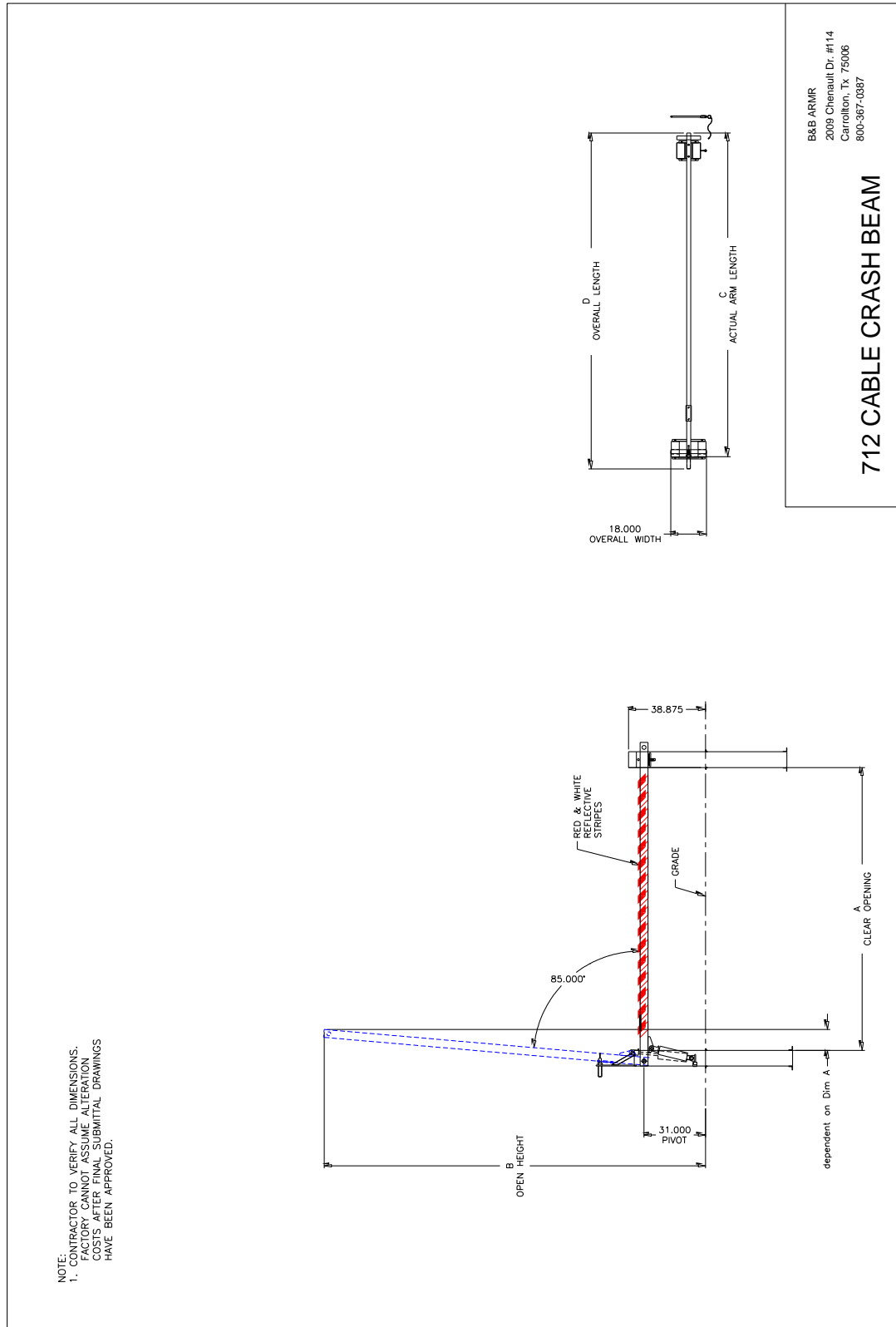

5.2.1 Table for above Gate Arm Measurements

A	B	C	D
144 [12]	192.458 [16-0 7/16]	164.750 [13-8 3/4]	171.00 [14-3]
156 [13]	210.279 [17-6 1/4]	176.750 [14-8 3/4]	183.00 [15-3]
168 [14]	216.367 [18-0 3/8]	188.75 [15-8 3/4]	195.00 [16-3]
180 [15]	228.248 [19-0 1/4]	200.75 [16-8 3/4]	207.00 [17-3]
192 [16]	240.624 [20-0 5/8]	212.75 [17-8 3/4]	219.00 [18-3]
204 [17]	252.533 [21-0 9/16]	224.75 [18-8 3/4]	231.00 [19-3]
216 [18]	264.533 [22-0 9/16]	236.75 [19-8 3/4]	243.00 [20-3]
228 [19]	276.487 [23-0 1/2]	248.75 [20-8 3/4]	255.00 [21-3]
240 [20]	288.442 [24-0 7/16]	260.75 [21-8 3/4]	267.00 [22-3]
252 [21]	300.093 [25-0 1/16]	272.75 [22-8 3/4]	289.00 [23-3]
264 [22]	312.093 [26-0 1/16]	284.75 [23-8 3/4]	301.00 [24-3]
276 [23]	324.302 [27-0 3/8]	296.75 [24-8.34]	313.00 [25-3]
288 [24]	336.259 [28-0 1/4]	308.75 [25-8 3/4]	325.00 [26-3]
300 [25]	348.213 [29-0 1/4]	320.75 [26-8 3/4]	349.00 [27-3]

5.2.2 Gate Arm Assembly

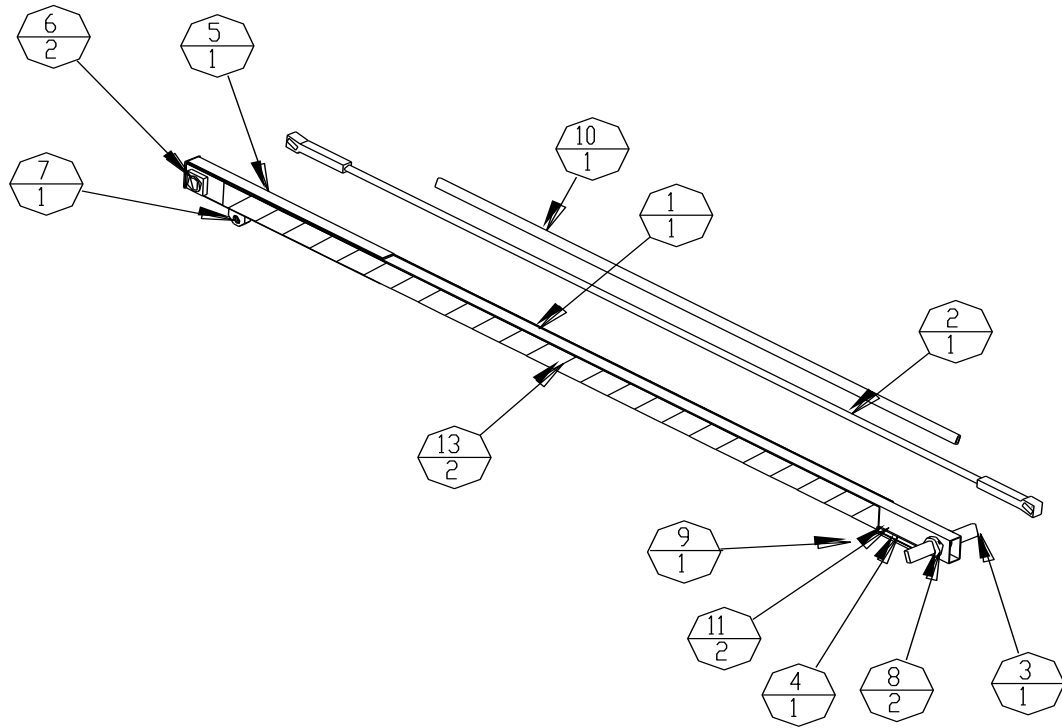

4	14	XTIE-7130K42	CABLE TIE, 6.375 LG, BLACK	
2	13	XTAPE-RED-WHITE	REFLECTIVE TAPE, RED/WHITE, ANGLED	
1	12	XTAPE-76675A23	ADHESIVE TAPE, DOUBLE SIDED, 3M VHB	
2	11	XSCR-91771A194	FHP, 8-32 X .5, SST	
1	10	XINS-3W192	INSULATION, PIPE, .875" ID, 1.5" OD	
1	9	XFOAM-86375K153	FOAM PAD, 3/8 THK, ADHESIVE BACK	
2	8	XCOLLAR-32ALUM	2" DIA, LOCKING COLLAR	
1	7	XBRG-EP162016	BEARING-1X125X1	
2	6	XBRG-EF323632	BUSHING, 2X2.25X2	
1	5	0712-3050	RUBBER PAD STEEL SLEEVE	
1	4	0712-3032	7/12/714 GATE ARM DELRIN PADS	
1	3	0712-3031	RECEIVER PIN MODEL 712-CRASH GATE	
1	2	0712-3018	STEEL CABLE	
1	1	0712-2025	GATE ARM WELDMENT STEEL SLEEVE	
QTY	FIND NO	PART OR IDENTIFYING NUMBER	NOMENCLATURE OR DESCRIPTION	NOTES