

# WESLO<sup>®</sup>

## cadence G-40

www.weslo.com

Model No. WLTL29606.9

Serial No. \_\_\_\_\_

Write the serial number in the space above for future reference.

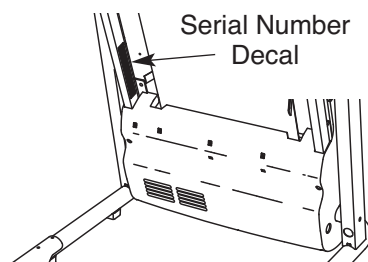

### QUESTIONS?

If you have questions, or if parts are damaged or missing, **DO NOT CONTACT THE STORE**; please contact Customer Care.

**IMPORTANT:** Please register this product (see the limited warranty on the back cover of this manual) before contacting Customer Care.

CALL TOLL-FREE:

**1-866-699-3756**

Mon.–Fri. 6 a.m.–6 p.m. MT

Sat. 8 a.m.–4 p.m. MT

ON THE WEB:

www.wesloservice.com

## USER'S MANUAL

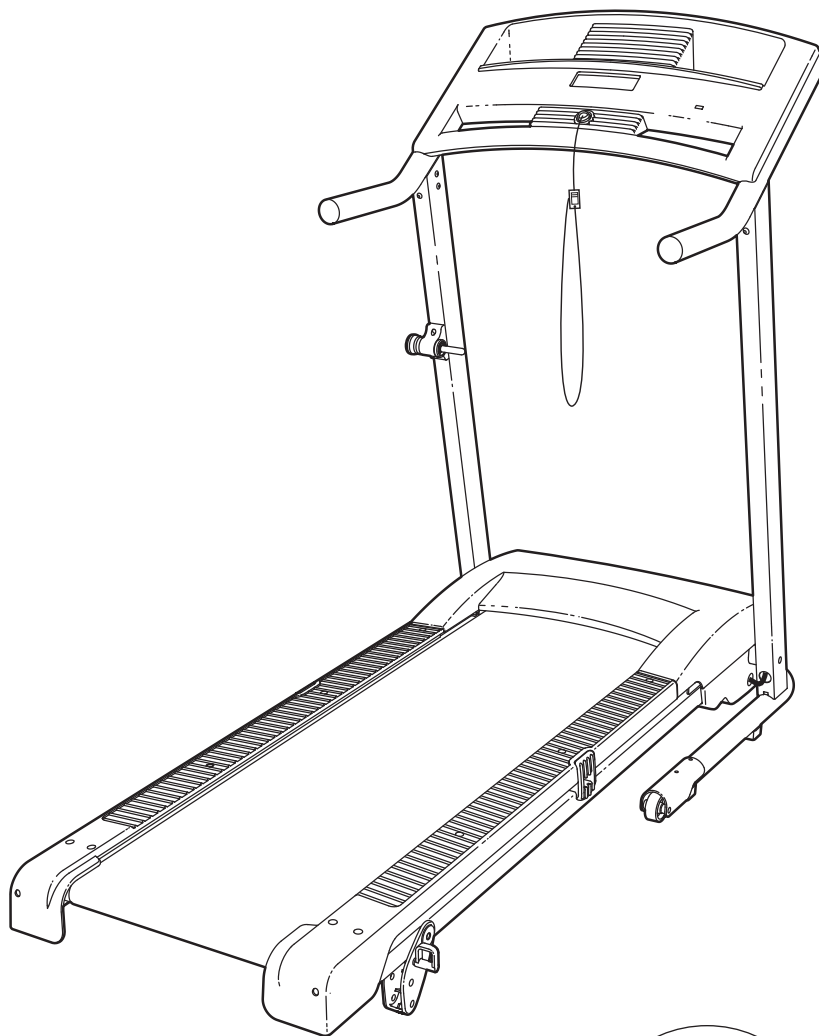

### **⚠ CAUTION**

Read all precautions and instructions in this manual before using this equipment. Save this manual for future reference.



# TABLE OF CONTENTS

WARNING DECAL PLACEMENT .....2

IMPORTANT PRECAUTIONS .....3

BEFORE YOU BEGIN .....5

ASSEMBLY .....6

OPERATION AND ADJUSTMENT .....12

HOW TO FOLD AND MOVE THE TREADMILL .....17

TROUBLESHOOTING .....19

EXERCISE GUIDELINES .....21

PART LIST .....22

EXPLODED DRAWING .....24

ORDERING REPLACEMENT PARTS ..... Back Cover



LIMITED WARRANTY ..... Back Cover

## WARNING DECAL PLACEMENT

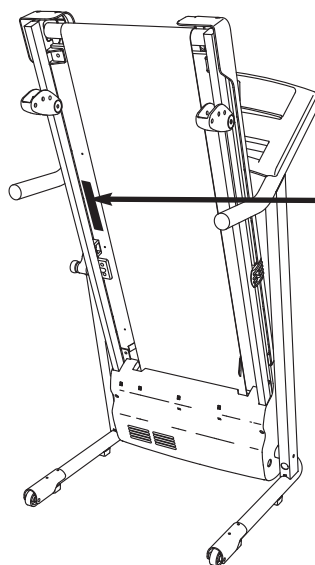
This drawing shows the location(s) of the warning decal(s). **If a decal is missing or illegible, call the telephone number on the front cover of this manual and request a free replacement decal. Apply the decal in the location shown.** Note: The decal(s) may not be shown at actual size.



**▲WARNING:**  
Protect yourself and others from risk of serious injury. Read the user's manual and :

-  •Stand only on the side rails when starting or stopping treadmill.
- Change speed in small increments.
- Hold handrails to prevent falling, and always wear the safety clip while operating treadmill.
- Stop if you feel faint, dizzy, or short of breath.
- Fully engage storage latch: before treadmill is moved or stored.
- Reduce incline to its lowest level before folding treadmill into storage position.
-  •Never allow children on or around treadmill.
- Remove key when not in use.
-  •Keep clothing, fingers, and hair away from moving belt.
- Never try to adjust or fix the belt while it is moving.
- Always wear athletic shoes while operating treadmill.

## IMPORTANT PRECAUTIONS

**⚠ WARNING:** To reduce the risk of serious injury, read all important precautions and instructions in this manual and all warnings on your treadmill before using your treadmill. ICON assumes no responsibility for personal injury or property damage sustained by or through the use of this product.

1. Before beginning this or any exercise program, consult your physician. This is especially important for persons over age 35 or persons with pre-existing health problems.
2. It is the responsibility of the owner to ensure that all users of this treadmill are adequately informed of all warnings and precautions.
3. Use the treadmill only as described.
4. Place the treadmill on a level surface, with at least 8 ft. (2.4 m) of clearance behind it and 2 ft. (0.6 m) on each side. Do not place the treadmill on any surface that blocks air openings. To protect the floor or carpet from damage, place a mat under the treadmill.
5. Keep the treadmill indoors, away from moisture and dust. Do not put the treadmill in a garage or covered patio, or near water.
6. Do not operate the treadmill where aerosol products are used or where oxygen is being administered.
7. Keep children under age 12 and pets away from the treadmill at all times.
8. The treadmill should not be used by persons weighing more than 250 lbs. (113 kg).
9. Never allow more than one person on the treadmill at a time.
10. Wear appropriate exercise clothes when using the treadmill. Do not wear loose clothes that could become caught in the treadmill. Athletic support clothes are recommended for both men and women. *Always wear athletic shoes; never use the treadmill with bare feet, wearing only stockings, or in sandals.*
11. When connecting the power cord (see page 12), plug the power cord into a surge suppressor (not included) and plug the surge suppressor into a grounded circuit capable of carrying 15 or more amps. No other appliance should be on the same circuit. Do not use an extension cord.
12. Use only a single-outlet surge suppressor that meets all of the specifications described on page 12. To purchase a surge suppressor, see your local WESLO dealer or call the telephone number on the front cover of this manual and order part number 146148, or see your local electronics store.
13. Failure to use a properly functioning surge suppressor could result in damage to the control system of the treadmill. If the control system is damaged, the walking belt may slow, accelerate, or stop unexpectedly, which may result in a fall and serious injury.
14. Keep the power cord and the surge suppressor away from heated surfaces.
15. Never move the walking belt while the power is turned off. Do not operate the treadmill if the power cord or plug is damaged, or if the treadmill is not working properly. (See TROUBLESHOOTING on page 19 if the treadmill is not working properly.)
16. Read, understand, and test the emergency stop procedure before using the treadmill (see HOW TO TURN ON THE POWER on page 13).
17. Never start the treadmill while you are standing on the walking belt. Always hold the handrails while using the treadmill.
18. The pulse sensor is not a medical device. Various factors, including your movement, may affect the accuracy of heart rate readings. The pulse sensor is intended only as an exercise aid in determining heart rate trends in general.
19. The treadmill is capable of high speeds. Adjust the speed in small increments to avoid sudden jumps in speed.

20. Never leave the treadmill unattended while it is running. Always remove the key, unplug the power cord, and switch the reset/off circuit breaker to the off position when the treadmill is not in use. (See the drawing on page 5 for the location of the circuit breaker.)
21. Do not attempt to raise, lower, or move the treadmill until it is properly assembled. (See ASSEMBLY on page 6 and HOW TO FOLD AND MOVE THE TREADMILL on page 17.) You must be able to safely lift 45 lbs. (20 kg) to raise, lower, or move the treadmill.
22. When folding or moving the treadmill, make sure that the storage latch is holding the frame securely in the storage position.
23. Do not change the incline of the treadmill by placing objects under the treadmill.
24. Inspect and properly tighten all parts of the treadmill regularly.
25. Never drop or insert any object into any opening on the treadmill.
26. **DANGER:** Always unplug the power cord immediately after use, before cleaning the treadmill, and before performing the maintenance and adjustment procedures described in this manual. Never remove the motor hood unless instructed to do so by an authorized service representative. Servicing other than the procedures in this manual should be performed by an authorized service representative only.
27. This treadmill is intended for in-home use only. Do not use this treadmill in any commercial, rental, or institutional setting.
28. Over exercising may result in serious injury or death. If you feel faint or if you experience pain while exercising, stop immediately and cool down.

**SAVE THESE INSTRUCTIONS**

## BEFORE YOU BEGIN

Thank you for selecting the new WESLO® CADENCE G-40 treadmill. The CADENCE G-40 treadmill offers a selection of features designed to make your workouts at home more effective. And when you're not exercising, the unique treadmill can be folded up, requiring less than half the floor space of other treadmills.

**For your benefit, read this manual carefully before using the treadmill.** If you have questions after read-

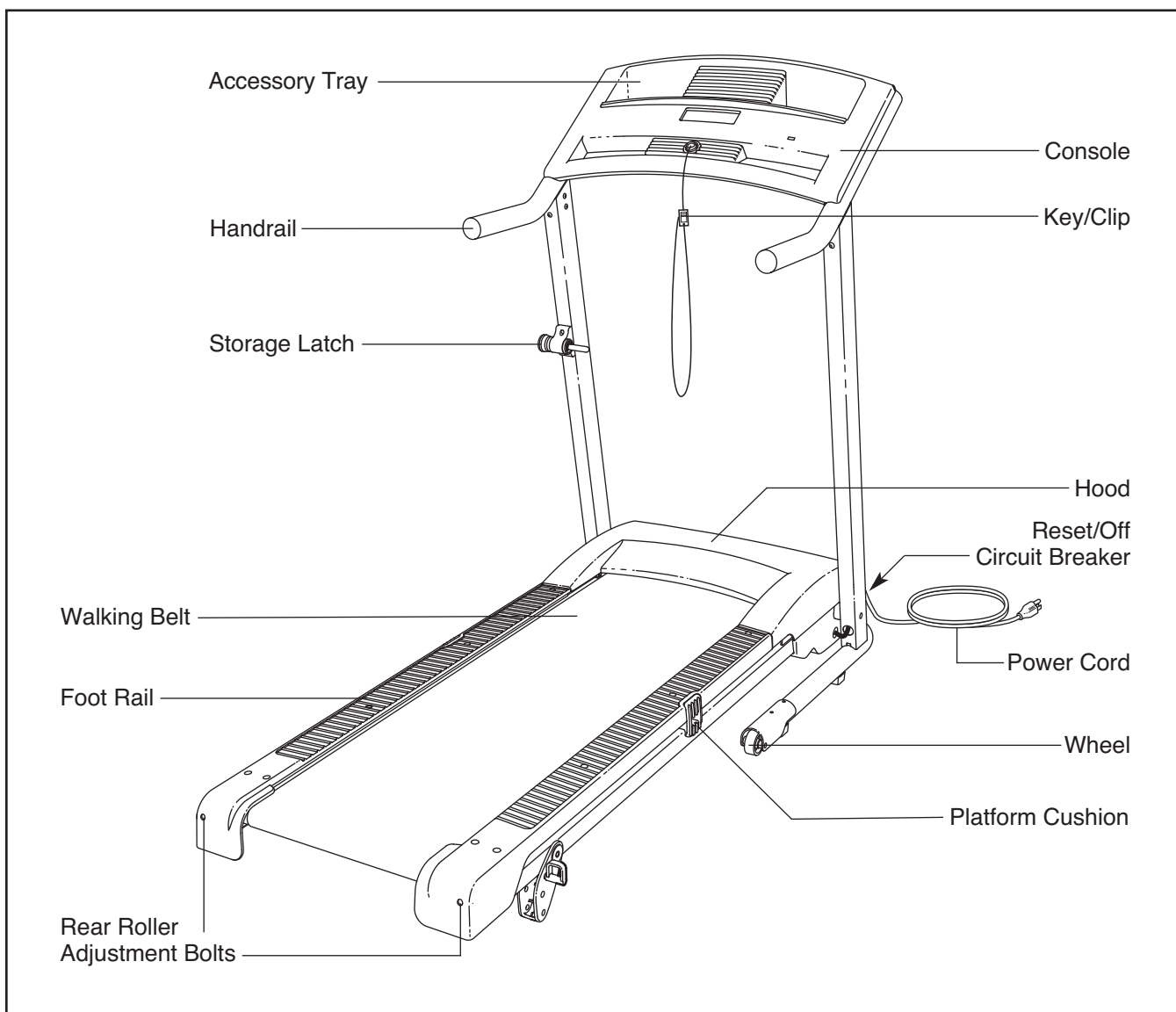

ing this manual, please see the front cover of this manual. To help us assist you, note the product model number and serial number before contacting us. The model number and the location of the serial number decal are shown on the front cover of this manual.

Before reading further, please review the drawing below and familiarize yourself with the labeled parts.



# ASSEMBLY

To hire an authorized service technician to assemble the treadmill, call toll-free 1-800-445-2480. Assembly requires two persons. Set the treadmill in a cleared area and remove all packing materials; **do not dispose of the packing materials until assembly is completed.** Note: The underside of the treadmill walking belt is coated with high-performance lubricant. During shipping, some lubricant may be transferred to the top of the walking belt or the shipping carton. This does not affect treadmill performance. If there is lubricant on top of the walking belt, simply wipe off the lubricant with a soft cloth and a mild, non-abrasive cleaner.

Assembly requires the included hex keys  and your own Phillips screwdriver , adjustable wrench , and needlenose pliers .

Use the drawings below to identify the assembly hardware. The number in parentheses below each drawing is the key number of the part, from the PART LIST near the end of this manual. The number after the parentheses is the quantity needed for assembly. **Note: Some parts may be preattached. To avoid damaging parts, do not use power tools for assembly. Extra hardware may be included.**

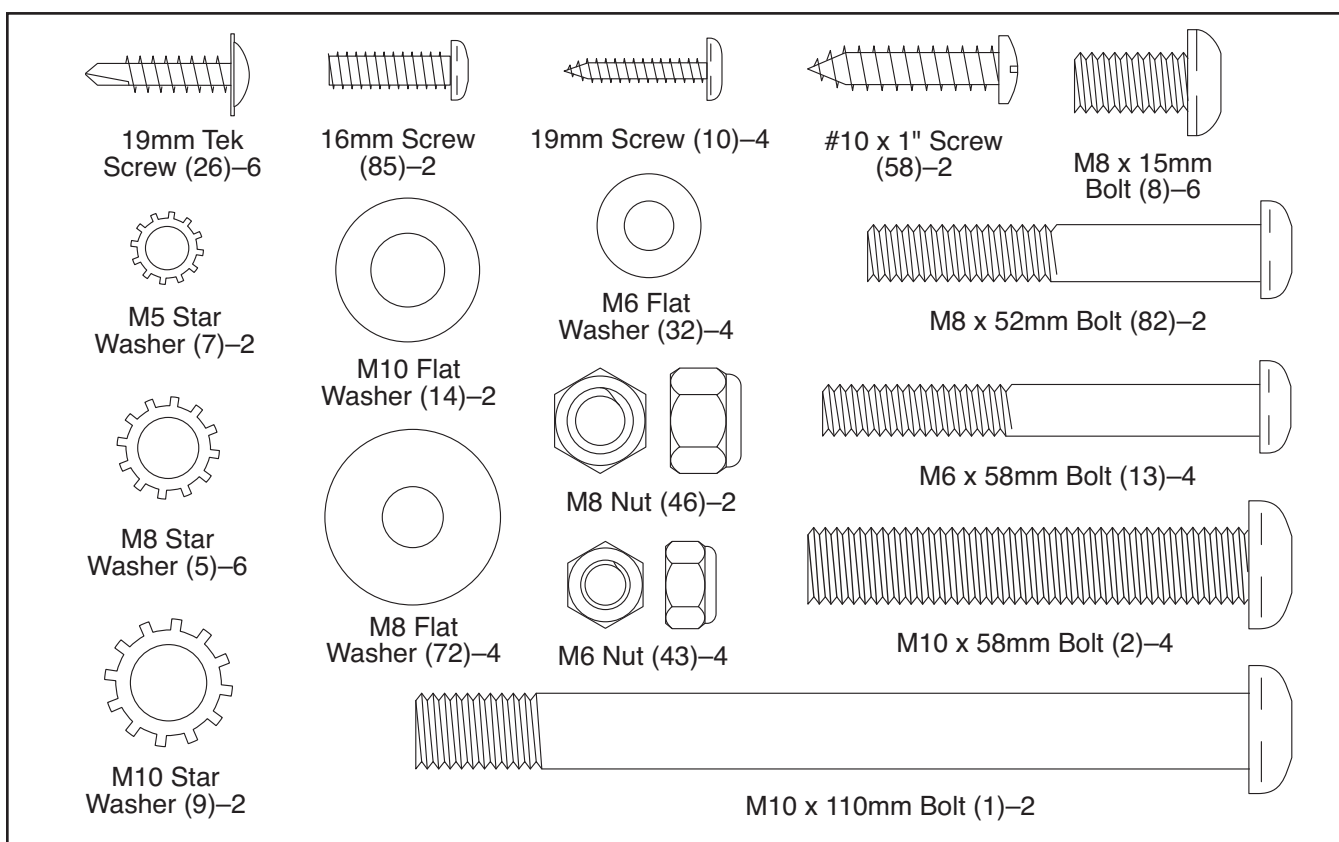

1. **Make sure that the power cord is unplugged. Place a piece of cardboard under the treadmill frame to protect the floor during assembly.**

Have a second person hold the Base (52) in the position shown.

Attach six Base Pads (63) to the Base (52) with six 19mm Tek Screws (26).

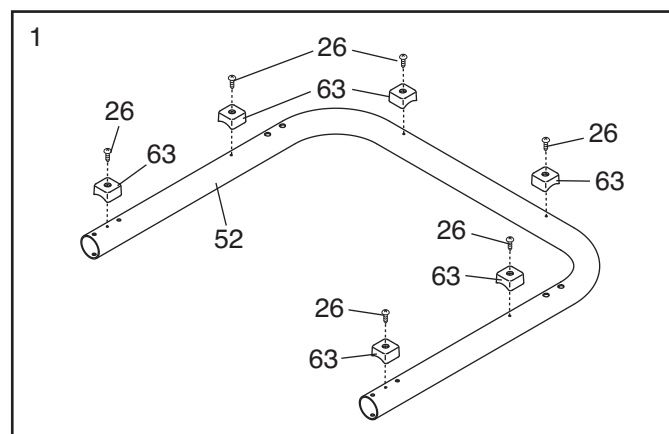

2. Have a second person hold the Base (52) in the position shown.

Identify the Right Upright (54), which has a large hole near the lower end.

**Hold the Right Upright (54) so that the large hole is oriented as shown.** Attach the Right Upright to the Base (52) with two M10 x R0710Amm Bolts (2). **Do not tighten the Bolts yet.**

**Attach the Left Upright (53) to the Base (52) in the same way.**

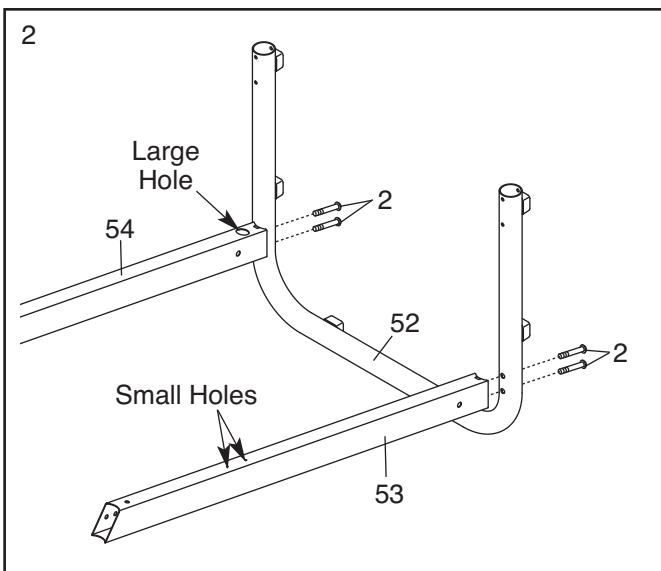

3. Slide the two Wheel Housings (45) onto the Base (52). Attach each Wheel Housing with two M6 x R0710Amm Bolts (13), two M6 Flat Washers (32), and two M6 Nuts (43).

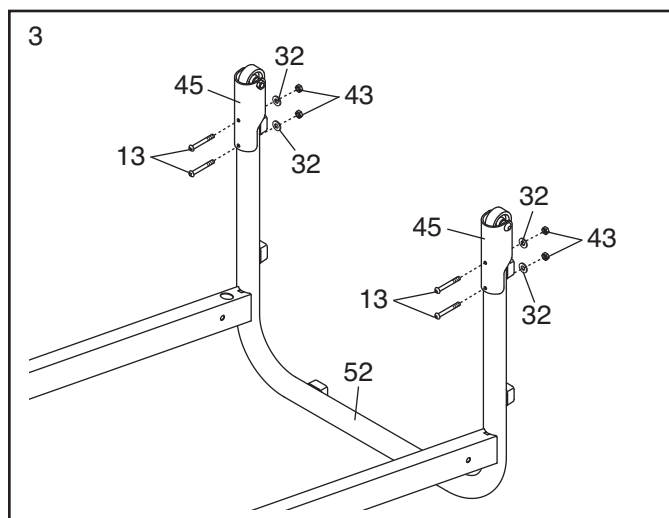

4. Remove and discard the bolts and the cardboard packaging from both sides of the Hood (65).

Position the Base (52) as close to the front of the treadmill as possible.

**See the inset drawing.** Locate the wire tie in the Right Upright (54). Tie the wire tie securely to the connector on the end of the Wire Harness (39). Next, pull the opposite end of the wire tie out of the upper end of the Right Upright, until the Wire Harness is routed completely through the Right Upright. Secure the Wire Harness to the upper end of the Right Upright so that it will not fall inside.

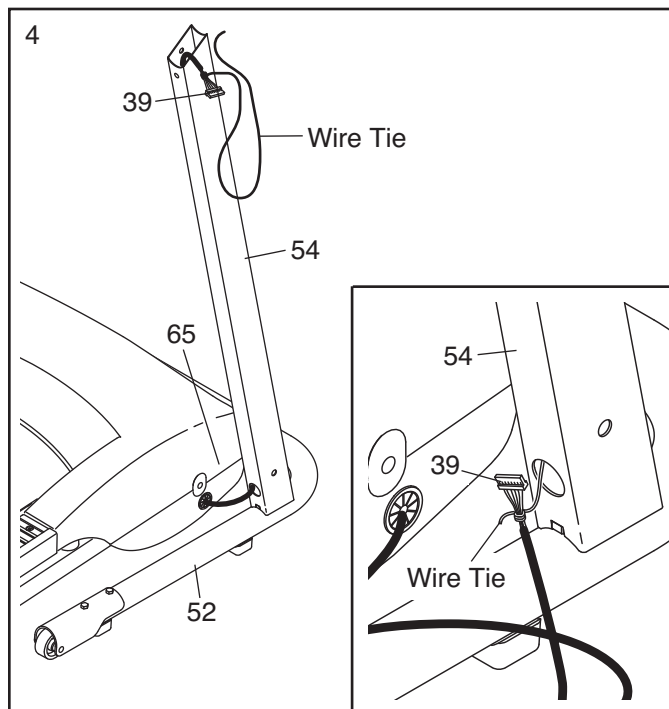

5. See the left inset drawing and identify a Frame Spacer (11). Hold the Frame Spacer between the Right Upright (54) and the Frame (51). Attach the Right Upright to the Frame with an M10 x 110mm Bolt (1), an M10 Flat Washer (14), and an M10 Star Washer (9); **do not tighten the Bolt yet.**

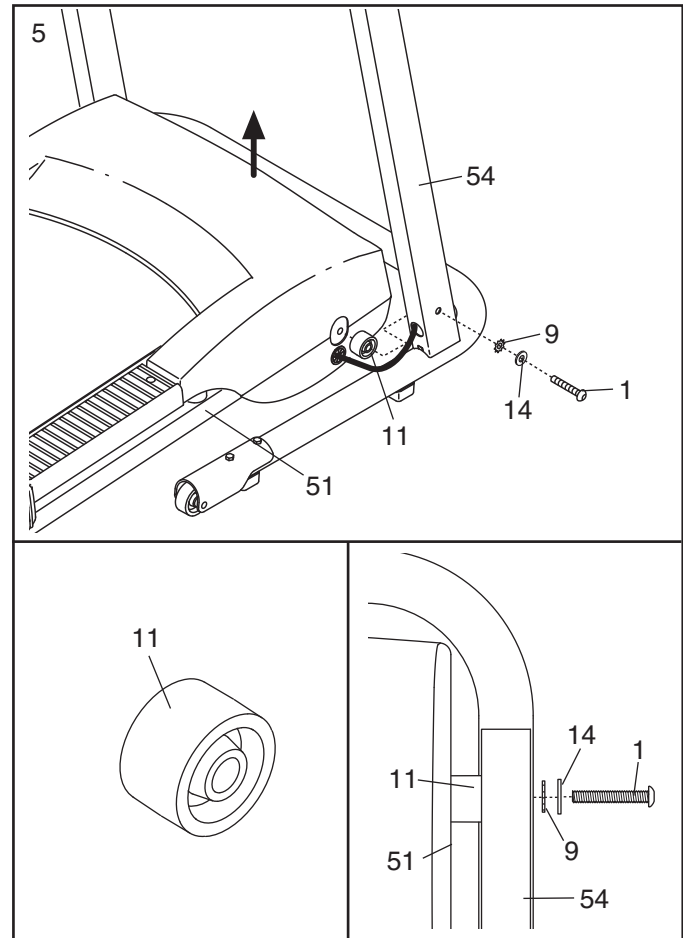

6. Hold the other Frame Spacer (11) between the Left Upright (53) and the Frame (51). Attach the Left Upright to the Frame with an M10 x 110mm Bolt (1), an M10 Flat Washer (14), and an M10 Star Washer (9); **do not tighten the Bolt yet.**

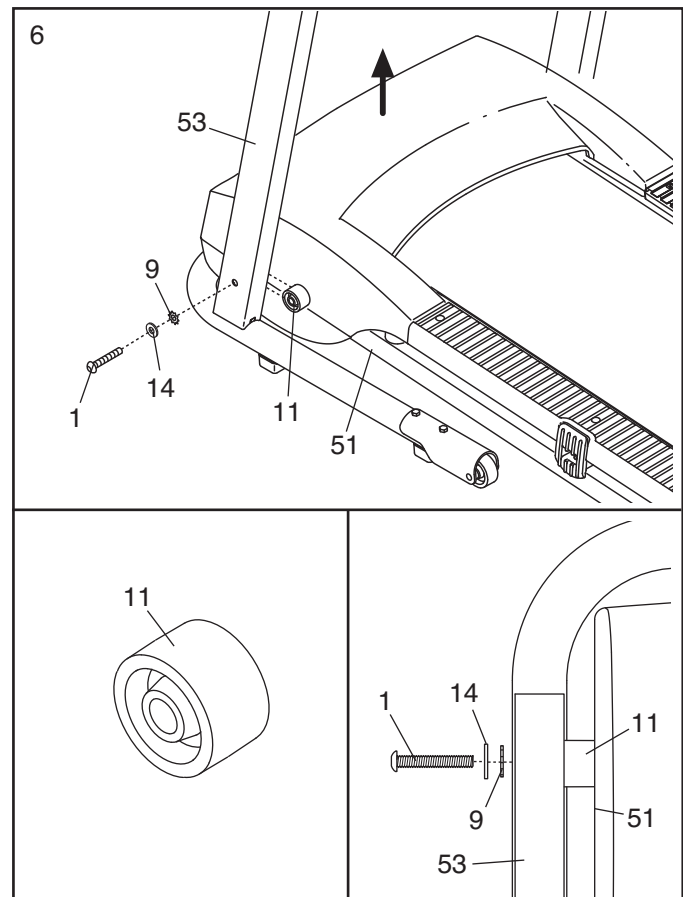



7. Set the Console (91) face down on a soft surface to avoid scratching it. Identify the Right Handrail (33), which has a large hole in the location shown. Hold the Right Handrail near the Console.

Next, insert the console wire into the large hole in the side of the Right Handrail (33). Using needle-nose pliers, carefully grasp the connector and pull the console wire out of the hole near the bracket on the Right Handrail.

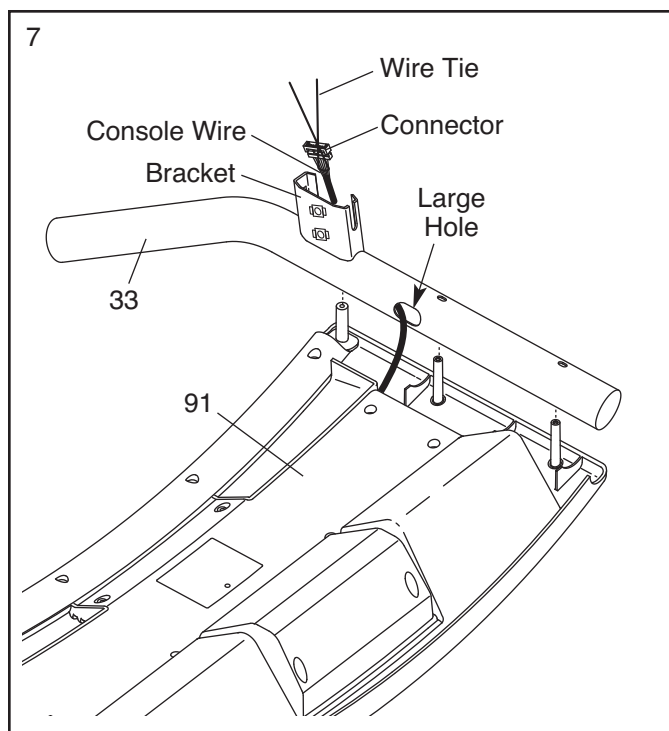

8. Set the Right Handrail (33) on the Console (91). **Make sure that the console wire is not pinched.** Start a 16mm Screw (85) with an M5 Star Washer (7) into the Right Handrail, and then start two 19mm Screws (10) into the Right Handrail. **Tighten the 16mm Screw and then tighten the two 19mm Screws; do not over-tighten the Screws.**

**Attach the Left Handrail (not shown) to the Console (91) in the same way.** Note: There is no wire on the left side.

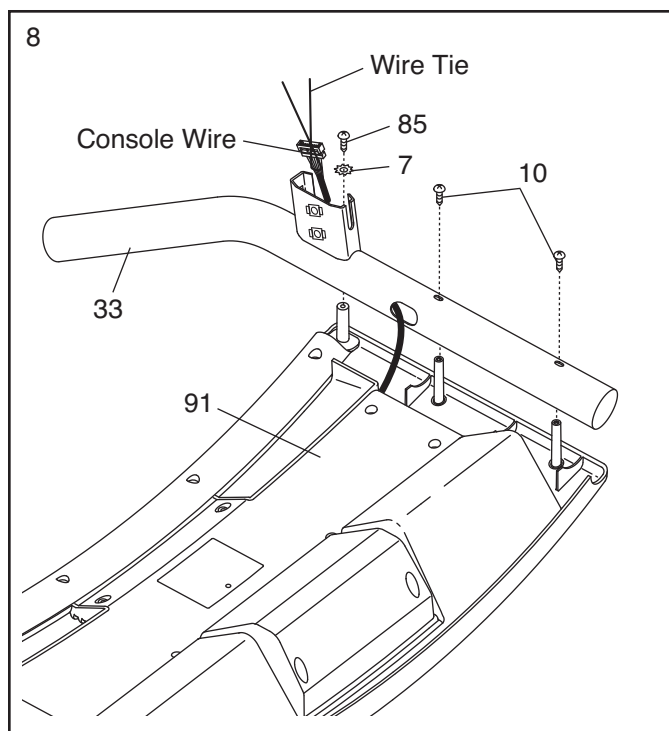

9. With the help of a second person, hold the Console (91) near the Right Upright (54).

Connect the Wire Harness (39) to the console wire. **See the inset drawing. The connectors should slide together easily and snap into place.** If they do not, turn one connector and try again. **IF THE CONNECTORS ARE NOT CONNECTED PROPERLY, THE CONSOLE MAY BE DAMAGED WHEN THE POWER IS TURNED ON.** Remove the wire tie from the Wire Harness. Insert the connectors and the excess wire downward into the Right Upright (54).

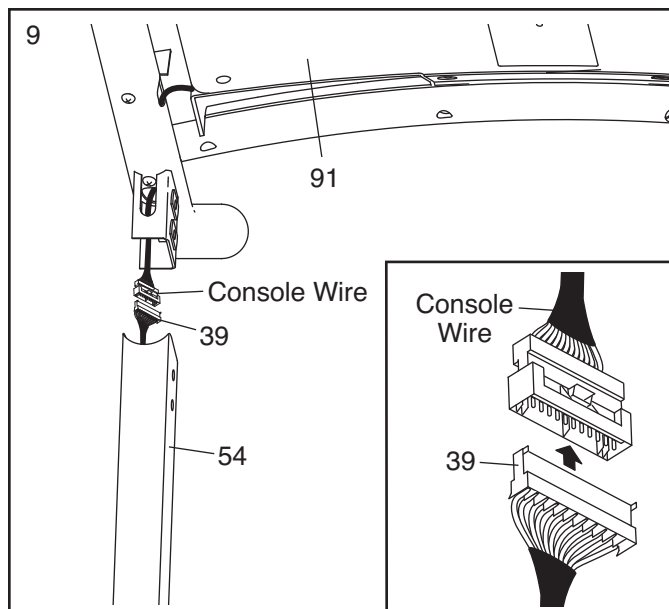

10. Set the Console (91) on the Uprights (53, 54). **Make sure that no wires are pinched.** Start four M8 x 15mm Bolts (8) with four M8 Star Washers (5) into the Uprights as shown. **Do not tighten the Bolts yet.**

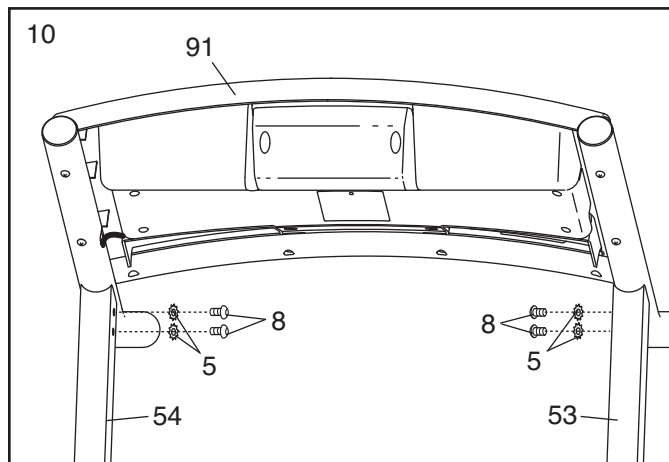

11. Start an M8 x 15mm Bolt (8) with an M8 Star Washer (5) into each Upright (53, 54). **Then, firmly tighten all six M8 x 15mm Bolts (8).**

With the help of a second person, carefully lower the Uprights (53, 54) to the floor.

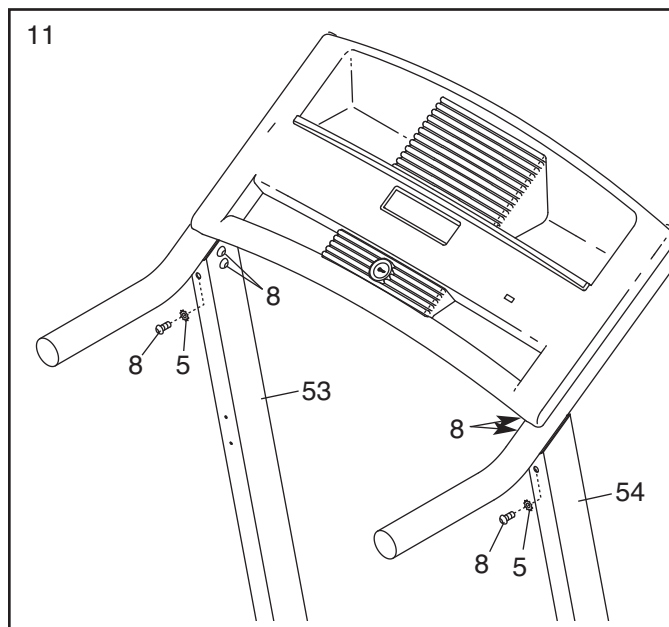

12. **See the lower drawing.** Position the Uprights (53, 54) so that the treadmill Frame (51) is centered between the Uprights.

Firmly tighten the two M10 x 110mm Bolts (1) and the four M10 x R0710Amm Bolts (2). **Be careful not to overtighten the M10 x 110mm Bolts.**

Raise the Uprights (53, 54).

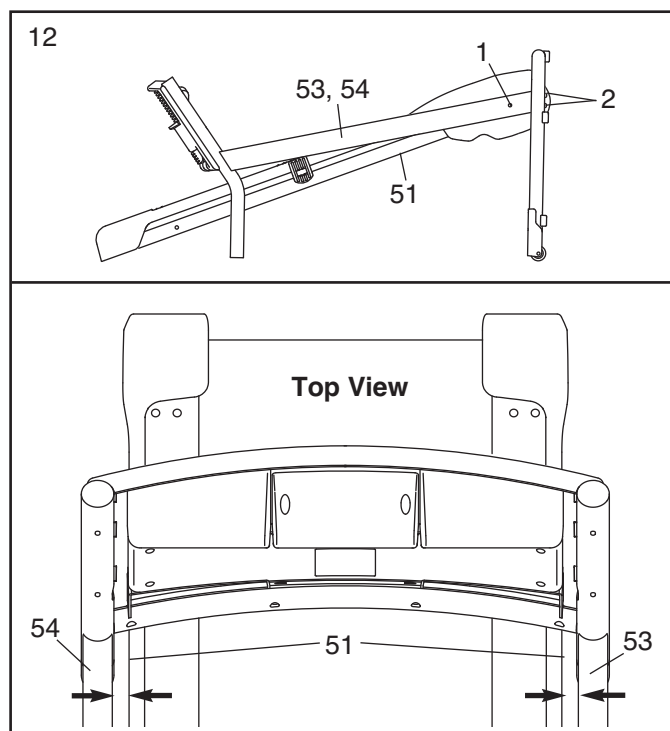

13. Attach the Latch Housing (48) to the Left Upright (53) with two #10 x 1" Screws (58); **start both Screws, and then tighten both of them.**

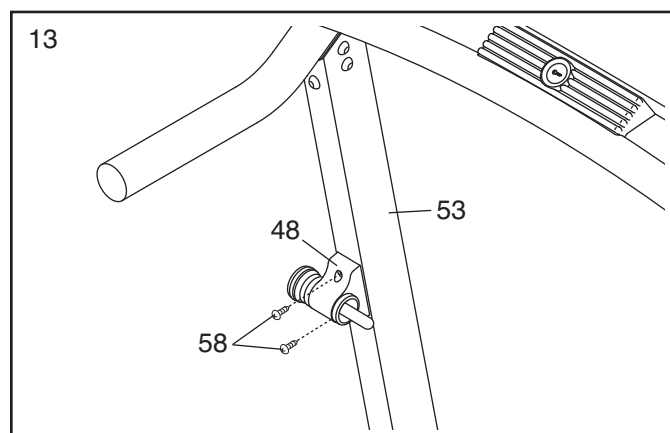

14. Raise the treadmill to the storage position (see HOW TO FOLD THE TREADMILL FOR STORAGE on page 17). Attach an Incline Leg (95) to each side of the Frame (51) with an M8 x 52mm Bolt (82), two M8 Flat Washers (72), and an M8 Nut (46) as shown. **Note: Do not overtighten the Nuts. The Incline Legs should rotate easily.**

Adjust the Incline Legs (95) to the desired incline (see page 16).

Lower the treadmill (see page 18).

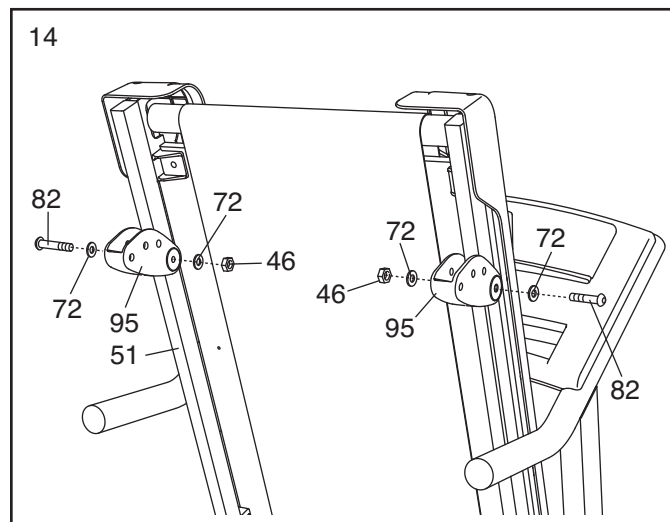

15. **Make sure that all parts are properly tightened before you use the treadmill.** Keep the included hex keys in a secure place. One of the hex keys is used to adjust the walking belt (see page 20). To protect the floor or carpet, place a mat under the treadmill.

## OPERATION AND ADJUSTMENT

### THE PRE-LUBRICATED WALKING BELT

Your treadmill features a walking belt coated with high-performance lubricant. **IMPORTANT: Never apply silicone spray or other substances to the walking belt or the walking platform. Such substances will deteriorate the walking belt and cause excessive wear.**

### HOW TO PLUG IN THE POWER CORD

**⚠ DANGER:** Improper connection of the equipment-grounding conductor can result in an increased risk of electric shock. Check with a qualified electrician or serviceman if you are in doubt as to whether the product is properly grounded. Do not modify the plug provided with the product—if it will not fit the outlet, have a proper outlet installed by a qualified electrician.

Your treadmill, like any other type of sophisticated electronic equipment, can be seriously damaged by sudden voltage changes in your home's power. Voltage surges, spikes, and noise interference can result from weather conditions or from other appliances being turned on or off. **To decrease the possibility of your treadmill being damaged, always use a surge suppressor with your treadmill (see drawing 1 at the right). To purchase a surge suppressor, see your local WESLO dealer or call the telephone number on the front cover of this manual and order part number 146148, or see your local electronics store.**

Use only a single-outlet surge suppressor that is UL 1449 listed as a transient voltage surge suppressor (TVSS). The surge suppressor must have a UL suppressed voltage rating of 400 volts or less and a minimum surge dissipation of 450 joules. The surge suppressor must be electrically rated for 120 volts AC and 15 amps. There must be a monitoring light on the surge suppressor to indicate whether it is functioning properly. Failure to use a properly functioning surge suppressor could result in damage to the control system of the treadmill. If the control system is damaged, the walking belt may slow, accelerate, or stop unexpectedly, which may result in a fall and serious injury.

**This product must be grounded.** If it should malfunction or break down, grounding provides a path of least resistance for electric current to reduce the risk of elec-

tric shock. This product is equipped with a cord having an equipment-grounding conductor and a grounding plug. **Plug the power cord into a surge suppressor, and plug the surge suppressor into an appropriate outlet that is properly installed and grounded in accordance with all local codes and ordinances. IMPORTANT: The treadmill is not compatible with GFCI-equipped outlets.**

This product is for use on a nominal 120-volt circuit, and has a grounding plug that looks like the plug illustrated in drawing 1 below. A temporary adapter that looks like the adapter illustrated in drawing 2 may be used to connect the surge suppressor to a 2-pole receptacle as shown in drawing 2 if a properly grounded outlet is not available.

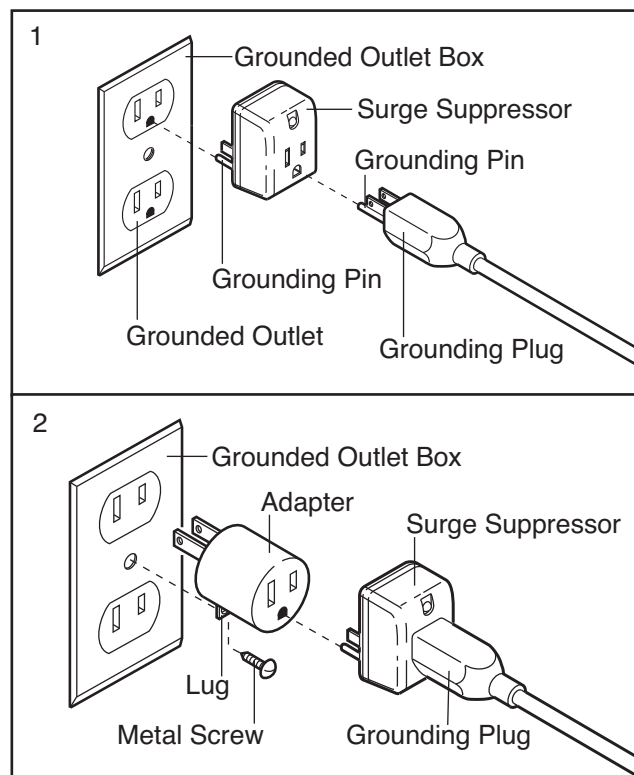

The temporary adapter should be used only until a properly grounded outlet (drawing 1) can be installed by a qualified electrician.

The green-colored rigid ear, lug, or the like extending from the adapter must be connected to a permanent ground such as a properly grounded outlet box cover. Whenever the adapter is used it must be held in place by a metal screw. **Some 2-pole receptacle outlet box covers are not grounded. Contact a qualified electrician to determine if the outlet box cover is grounded before using an adapter.**

## CONSOLE DIAGRAM

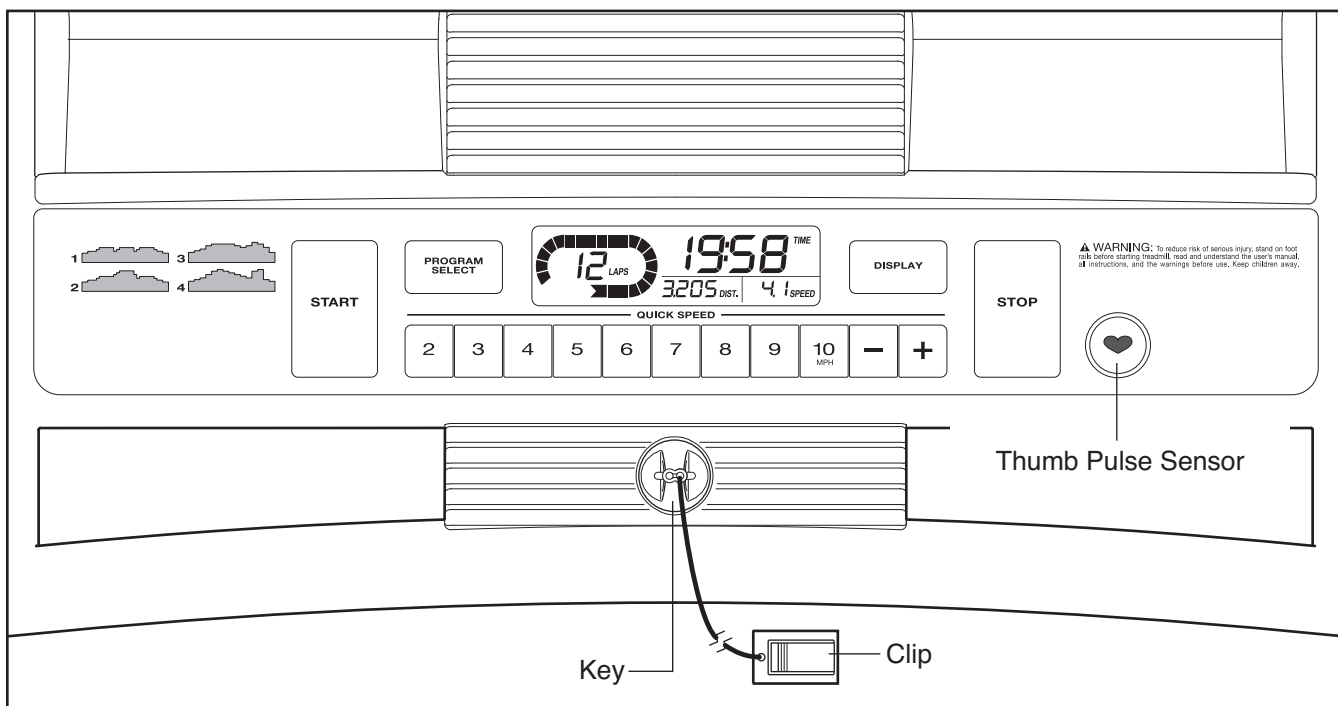

### FEATURES OF THE CONSOLE

The treadmill console offers a selection of features designed to make your workouts more effective.

When you select the manual mode of the console, you can change the speed of the treadmill with the touch of a button. As you exercise, the displays will provide continuous exercise feedback. You can even measure your heart rate using the built-in pulse sensor.

The console also offers four speed programs. Each program automatically controls the speed of the treadmill as it guides you through an effective workout.

**IMPORTANT: If there is a sheet of plastic on the face of the console, remove the plastic. To prevent damage to the walking platform, wear clean athletic shoes while using the treadmill. The first time the treadmill is used, observe the alignment of the walking belt, and center the walking belt if necessary (see page 20).**

### HOW TO TURN ON THE POWER

**IMPORTANT: If the treadmill has been exposed to cold temperatures, allow it to warm to room temperature before turning on the power. If you do not do this, you may damage the console displays or other electrical components.**

Plug in the power cord (see page 12). Next, locate the reset/off circuit breaker on the treadmill frame near the power cord. Make sure that the circuit breaker is in the “reset” position.

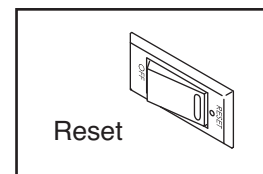

Next, stand on the foot rails of the treadmill. Find the clip attached to the key (see the drawing above), and slide the clip onto the waistband of your clothes. Then, insert the key into the console. After a moment, the displays will light. **IMPORTANT: In an emergency situation, the key can be pulled from the console, causing the walking belt to slow to a stop. Test the clip by carefully taking a few steps backward; if the key is not pulled from the console, adjust the position of the clip.**

## HOW TO USE THE MANUAL MODE

### 1. Insert the key into the console.

See HOW TO TURN ON THE POWER on page 13.

### 2. Select the manual mode.

When the key is inserted, the manual mode will be selected. If you have selected a speed program, reselect the manual mode by pressing the Program Select button repeatedly until only zeros appear in the displays.



### 3. Start the walking belt.

To start the walking belt, press the Start button, the speed increase button, or one of the numbered speed buttons.

If you press the Start button or the speed increase button, the walking belt will begin to move at 1 mph. As you exercise, change the speed of the walking belt as desired by pressing the speed increase and decrease buttons. Each time you press a button, the speed setting will change by 0.1 mph; if you hold down a button, the speed setting will change in increments of 0.5 mph. Note: After you press the buttons, it may take a moment for the walking belt to reach the selected speed setting.

If you press one of the numbered speed buttons, the walking belt will gradually change speed until it reaches the selected speed setting.

To stop the walking belt, press the Stop button. The time will begin to flash in one of the displays. To restart the walking belt, press the Start button or the speed increase button.

### 4. Follow your progress with the track and the displays.

**The track**—The track represents a distance of 1/4 mile (400 meters). As you walk or run on the treadmill, the indicators around the track will appear in succession until the entire track appears. The track will then disappear and the indicators will again begin to appear in succession. The center of the track will show the number of laps that you have completed.

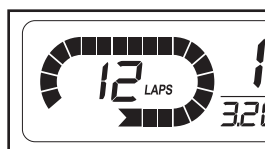

### The lower left display—

As you exercise, the lower left display can show the elapsed time and the distance that you have walked or run.



### The lower right display—

The lower right display can show the speed of the walking belt and the approximate number of calories that you have burned. The display also shows your heart rate when you use the pulse sensor (see step 5 on page 15).

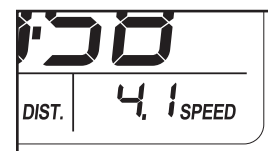

### The upper display—

The upper display can show the elapsed time, the distance that you have walked or run, the speed of the walking belt, or the approximate number of calories you have burned. Press the Display button repeatedly until the upper display shows the information that you are most interested in viewing. Note: While information is shown in the upper display, the same information will not be shown in the lower displays.



To reset the displays, press the Stop button, remove the key, and then reinsert the key.

Note: The console can display speed and distance in either miles or kilometers. To see which unit of measurement is selected, first remove the key from the console. Next, hold down the Stop button, reinsert the key, wait until you hear a tone, and then release the Stop button. An “E” for English miles or an “M” for metric kilometers will appear in the upper display. Press the speed increase button to change the unit of measurement if desired. When the desired unit of measurement is selected, remove the key and then reinsert it.

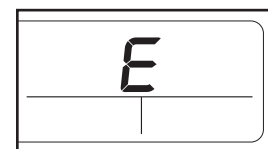

## 5. Measure your heart rate if desired.

To measure your heart rate, **stand on the foot rails** and place your thumb on the pulse sensor (see the drawing on page 13). **Do not press too hard, or the circulation in your thumb will be restricted and your pulse may not be detected.**

When your pulse is detected, the small heart symbol in the lower right display will flash, one or two dashes will appear, and then your heart rate will be shown. **For the most accurate heart rate reading, hold your thumb on the pulse sensor for at least 15 seconds.**

If the displayed heart rate appears to be too high or too low, or if your heart rate is not displayed, lift your thumb for a few seconds, and then reposition your thumb on the pulse sensor. Remember to stand still while measuring your heart rate.

## 6. When you are finished exercising, remove the key from the console.

Step onto the foot rails, press the Stop button, remove the key from the console, and put it in a secure place. When you are finished using the treadmill, switch the reset/off circuit breaker to the "off" position and unplug the power cord. **IMPORTANT: If you do not do this, the treadmill's electrical components may wear prematurely.**

## HOW TO USE A SPEED PROGRAM

### 1. Insert the key into the console.

See HOW TO TURN ON THE POWER on page 13.

### 2. Select one of the four speed programs.

To select a speed program, press the Program Select button repeatedly; "P- 1," "P- 2," "P- 3," or "P- 4" will appear in the upper display for a few seconds to show which program is selected. The maximum speed setting of the selected program will also flash in one of the displays for a few seconds.

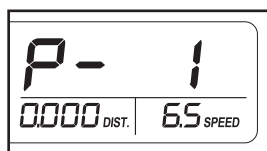

Each program consists of 30 one-minute periods. One speed setting is programmed for each period. Note: The same speed setting may be programmed for consecutive periods. The profiles on the console show how the speed of the walking belt will change during the programs.

### 3. Start the walking belt.

Press the Start button or the speed increase button to start the program. When you press either button, the treadmill will automatically adjust to the speed setting that is programmed for the first period of the program. Hold the handrails and begin walking.

When the first period ends, a series of tones will sound. If a different speed setting is programmed for the second period, the speed setting will flash in one of the displays to alert you, and then **the speed of the walking belt will change.** The program will continue until all 30 periods are completed. The walking belt will then slow to a stop.

If the speed setting is too high or too low during the program, you can manually override the setting by pressing the speed buttons. However, **when the next period begins, the speed of the walking belt will change if a different speed setting is programmed for the next period.**

To stop the program, press the Stop button. The time will begin to flash in one of the displays. To restart the program, press the Start button or the speed increase button. The walking belt will begin to move at 1 mph. When the next period begins, the speed of the walking belt will change if a different speed setting is programmed for the next period.

### 4. Follow your progress with the track and the displays.

See step 4 on page 14.

### 5. Measure your heart rate if desired.

See step 5 on this page.

### 6. When you are finished exercising, remove the key from the console.

See step 6 on this page.

## HOW TO CHANGE THE INCLINE OF THE TREADMILL

To vary the intensity of your exercise, you can change the incline of the treadmill. There are three incline levels. **Before changing the incline, remove the key and unplug the power cord.** Next, fold the treadmill to the storage position (see page 17).

To change the incline, first remove the incline pin from one of the incline legs. Adjust the incline leg to the desired position, and then fully reinsert the incline pin. Adjust the other incline leg in the same way. **CAUTION: Before using the treadmill, make sure that both incline legs are at the same height and that both incline pins are fully inserted into the incline legs.**

After you have adjusted the incline legs, lower the treadmill (see page 18).

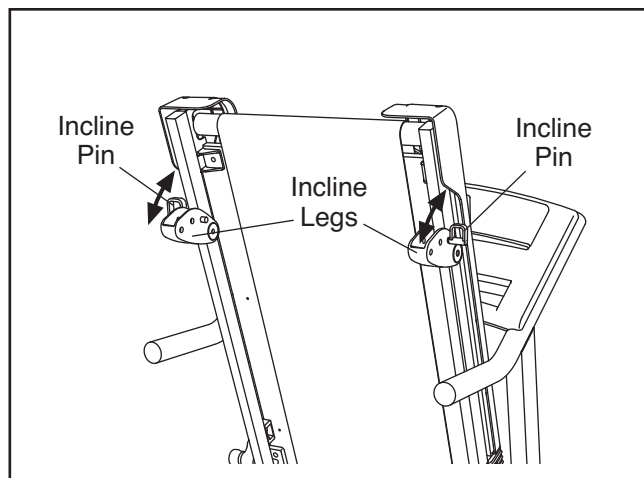



# HOW TO FOLD AND MOVE THE TREADMILL

## HOW TO FOLD THE TREADMILL FOR STORAGE

Before folding the treadmill, remove the key and unplug the power cord. **CAUTION:** You must be able to safely lift 45 lbs. (20 kg) to raise, lower, or move the treadmill.

1. Hold the metal frame firmly in the location shown by the arrow at the right. **CAUTION:** To decrease the possibility of injury, do not lift the frame by the plastic foot rails. Make sure to bend your legs and keep your back straight. As you raise the frame, make sure to lift with your legs rather than your back. Raise the frame about halfway to the vertical position.

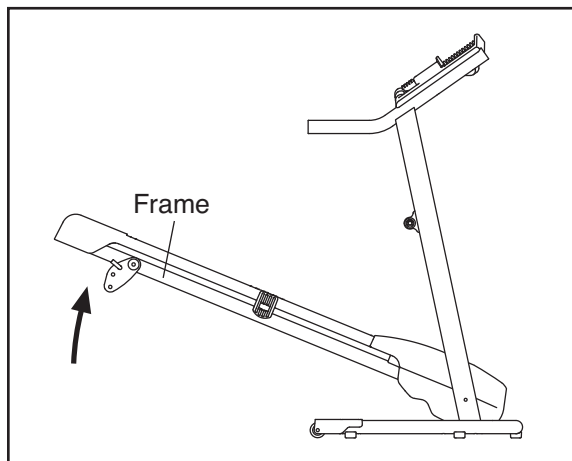

2. Move your right hand to the position shown and hold the treadmill firmly. Using your left hand, pull the latch knob to the left and hold it. Raise the frame until the catch is past the latch pin. Then, slowly release the latch knob; make sure that the catch is resting against the latch pin.

To protect the floor or carpet from damage, place a mat under the treadmill. Keep the treadmill out of direct sunlight. Do not leave the treadmill in the storage position in temperatures above 85° F (30° C).

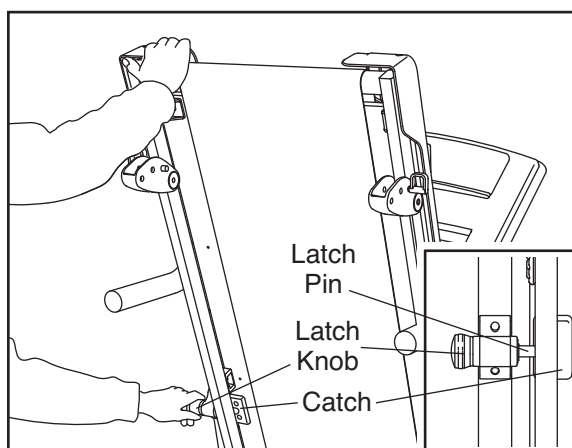

## HOW TO MOVE THE TREADMILL

Before moving the treadmill, convert the treadmill to the storage position as described above. **Make sure that the catch is resting against the latch pin.**

1. Hold the handrails and place one foot against one of the wheels. **Do not pull back on the frame.**
2. Tip the treadmill backward until it rolls freely on the wheels, and carefully move the treadmill to the desired location. **Never move the treadmill without tipping it backward. To reduce the risk of injury, use extreme caution while moving the treadmill. Do not attempt to move the treadmill over an uneven surface.**
3. Place one foot against one of the wheels, and carefully lower the treadmill until it is in the storage position.

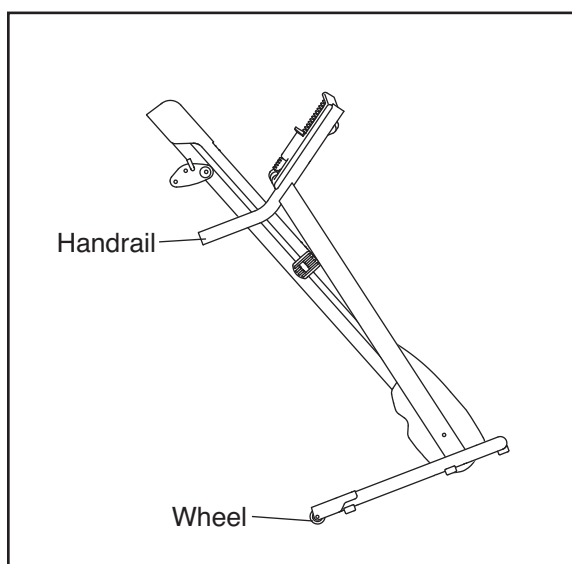

## HOW TO LOWER THE TREADMILL FOR USE

1. Hold the upper end of the treadmill with your right hand as shown. Using your left hand, pull the latch knob to the left and hold it. Next, lower the frame until it is past the latch pin. Then, release the latch knob.

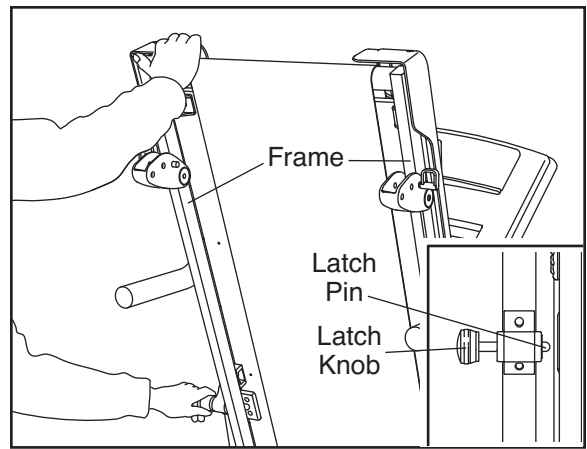

2. Hold the frame firmly with both hands, and lower it to the floor. **To decrease the possibility of injury, bend your legs and keep your back straight.**

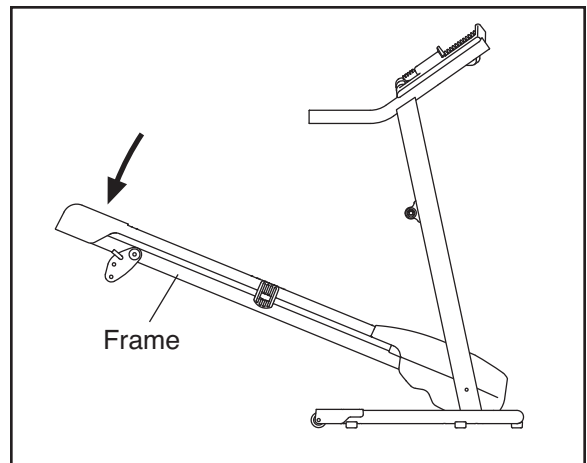

## TROUBLESHOOTING

Most treadmill problems can be solved by following the steps below. Find the symptom that applies, and follow the steps listed. If further assistance is needed, please see the front cover of this manual.

**PROBLEM: The power does not turn on**

**SOLUTION:** a. Make sure that the power cord is plugged into a surge suppressor, and that the surge suppressor is plugged into a properly grounded outlet (see page 12). Use only a single-outlet surge suppressor that meets all of the specifications described on page 12. **IMPORTANT: The treadmill is not compatible with GFCI-equipped outlets.**

b. After the power cord has been plugged in, make sure that the key is inserted into the console.

c. Check the reset/off circuit breaker located on the treadmill frame near the power cord. If the switch protrudes as shown, the circuit breaker has tripped. To reset the circuit breaker, wait for five minutes, and then press the switch back in.

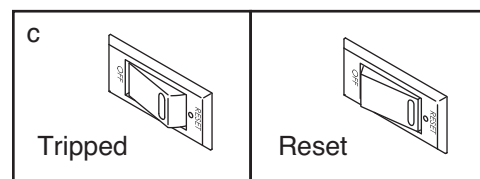

**PROBLEM: The power turns off during use**

**SOLUTION:** a. Check the reset/off circuit breaker (see the drawing above). If the circuit breaker has tripped, wait for five minutes and then press the switch back in.

b. Make sure that the power cord is plugged in.

c. Remove the key from the console. Reinsert the key into the console.

d. If the treadmill still will not run, please see the front cover of this manual.

**PROBLEM: The displays of the console do not function properly**

**SOLUTION:** a. Remove the key from the console and **UNPLUG THE POWER CORD**. Remove the three indicated Hood Screws (20) and two Foot Rail Screws (25). Then, carefully remove the Hood (65).

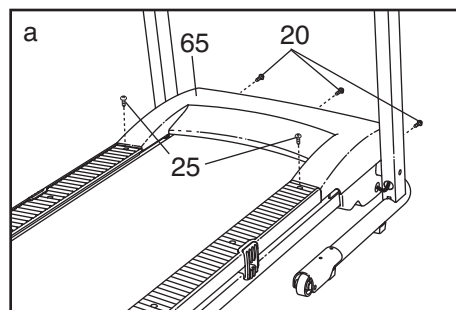

Locate the Reed Switch (89) and the Magnet (62) on the left side of the Pulley (71). Turn the Pulley until the Magnet is aligned with the Reed Switch. **Make sure that the gap between the Magnet and the Reed Switch is about 1/8 in. (3 mm).** If necessary, loosen the Reed Switch Screw (3), move the Reed Switch slightly, and then retighten the Screw. Reattach the Hood (not shown), and run the treadmill for a few minutes to check for a correct speed reading.

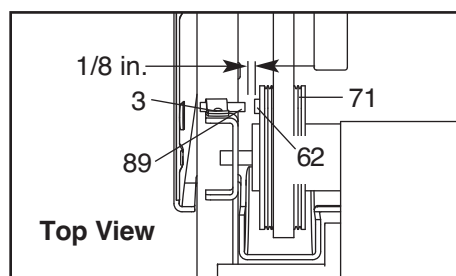

**PROBLEM: The walking belt slows when walked on**

**SOLUTION:** a. Use only a single-outlet surge suppressor that meets all of the specifications described on page 12.

- b. If the walking belt is overtightened, treadmill performance may decrease and the walking belt may become damaged. Remove the key and **UNPLUG THE POWER CORD**. Using the hex key, turn both rear roller bolts counterclockwise, 1/4 of a turn. When the walking belt is properly tightened, you should be able to lift each edge of the walking belt 2 to 3 in. (5 to 7 cm) off the walking platform. Be careful to keep the walking belt centered. Then, plug in the power cord, insert the key, and run the treadmill for a few minutes. Repeat until the walking belt is properly tightened.

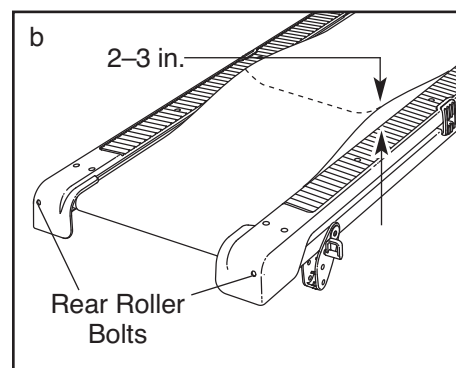

- c. If the walking belt still slows when walked on, see the front cover of this manual.

**PROBLEM: The walking belt is off-center or slips when walked on**

**SOLUTION:** a. **If the walking belt has shifted to the left**, first remove the key and **UNPLUG THE POWER CORD**. Using the hex key, turn the left rear roller bolt clockwise 1/2 of a turn. Be careful not to overtighten the walking belt. **If the walking belt has shifted to the right**, turn the left rear roller bolt counterclockwise 1/2 of a turn. Then, plug in the power cord, insert the key, and run the treadmill for a few minutes. Repeat until the walking belt is centered.

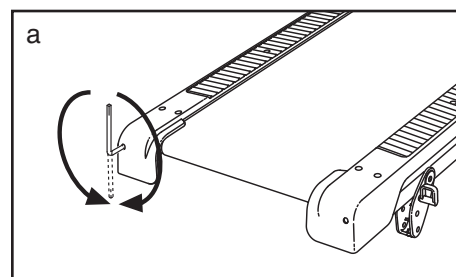

- b. **If the walking belt slips when walked on**, first remove the key and **UNPLUG THE POWER CORD**. Using the hex key, turn both rear roller bolts clockwise, 1/4 of a turn. When the walking belt is correctly tightened, you should be able to lift each edge of the walking belt 2 to 3 in. (5 to 7 cm) off the walking platform. Be careful to keep the walking belt centered. Then, plug in the power cord, insert the key, and carefully walk on the treadmill for a few minutes. Repeat until the walking belt is properly tightened.

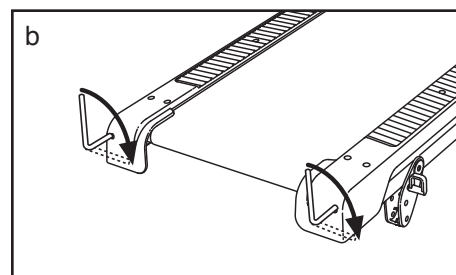

## EXERCISE GUIDELINES

**⚠️ WARNING:** Before beginning any exercise program, consult your physician. This is especially important for persons over age 35 or persons with pre-existing health problems.

The pulse sensor is not a medical device. Various factors may affect the accuracy of heart rate readings. The pulse sensor is intended only as an exercise aid in determining heart rate trends in general.

These guidelines will help you to plan your exercise program. For detailed exercise information, obtain a reputable book or consult your physician. Remember, proper nutrition and adequate rest are essential for successful results.

### EXERCISE INTENSITY

Whether your goal is to burn fat or to strengthen your cardiovascular system, exercising at the proper intensity is the key to achieving results. You can use your heart rate as a guide to find the proper intensity level. The chart below shows recommended heart rates for fat burning and aerobic exercise.

165	155	145	140	130	125	115	♥
145	138	130	125	118	110	103	♥
125	120	115	110	105	95	90	♥
<hr/>							
20	30	40	50	60	70	80	

To find the proper intensity level, find your age at the bottom of the chart (ages are rounded off to the nearest ten years). The three numbers listed above your age define your “training zone.” The lowest number is the heart rate for fat burning, the middle number is the heart rate for maximum fat burning, and the highest number is the heart rate for aerobic exercise.

**Burning Fat**—To burn fat effectively, you must exercise at a low intensity level for a sustained period of time. During the first few minutes of exercise, your body uses *carbohydrate calories* for energy. Only after the first few minutes of exercise does your body begin to use stored *fat calories* for energy. If your goal is to burn fat, adjust the intensity of your exercise until your heart rate is near the lowest number in your training zone. For maximum fat burning, exercise with your heart rate near the middle number in your training zone.

**Aerobic Exercise**—If your goal is to strengthen your cardiovascular system, you must perform aerobic exercise, which is activity that requires large amounts of oxygen for prolonged periods of time. For aerobic exercise, adjust the intensity of your exercise until your heart rate is near the highest number in your training zone.

### WORKOUT GUIDELINES

**Warming Up**—Start with 5 to 10 minutes of stretching and light exercise. A warm-up increases your body temperature, heart rate, and circulation in preparation for exercise.

**Training Zone Exercise**—Exercise for 20 to 30 minutes with your heart rate in your training zone. (During the first few weeks of your exercise program, do not keep your heart rate in your training zone for longer than 20 minutes.) Breathe regularly and deeply as you exercise—never hold your breath.

**Cooling Down**—Finish with 5 to 10 minutes of stretching. Stretching increases the flexibility of your muscles and helps to prevent post-exercise problems.

### EXERCISE FREQUENCY

To maintain or improve your condition, complete three workouts each week, with at least one day of rest between workouts. After a few months of regular exercise, you may complete up to five workouts each week, if desired. Remember, the key to success is to make exercise a regular and enjoyable part of your everyday life.

**PART LIST—Model No. WLTL29606.9**

R0710A

To locate the parts listed below, see the EXPLODED DRAWING near the end of this manual.

Key No.	Qty.	Description	Key No.	Qty.	Description
1	2	M10 x 110mm Bolt	51	1	Frame
2	4	M10 x 58mm Bolt	52	1	Base
3	2	Wire Tie Screw/Reed Switch Screw	53	1	Left Upright
4	16	16mm Screw	54	1	Right Upright
5	6	M8 Star Washer	55	1	Rear Roller
6	1	Warning Decal	56	1	Motor Belt
7	2	M5 Star Washer	57	1	Electronics Bracket
8	6	M8 x 15mm Bolt	58	2	#10 x 1" Screw
9	2	M10 Star Washer	59	1	Motor Bracket
10	10	19mm Screw	60	1	Left Rear Roller Bracket
11	2	Frame Spacer	61	1	Right Rear Roller Bracket
12	1	Console Back	62	1	Magnet
13	4	M6 x 58mm Bolt	63	6	Base Pad
14	2	M10 Flat Washer	64	1	Latch Catch
15	1	Key/Clip	65	1	Hood
16	2	M10 Nut	66	1	Belly Pan
17	1	6mm Hex Key	67	1	Left Foot Rail
18	1	4mm Hex Key	68	1	Right Foot Rail
19	4	Roller Bracket Screw/ Front Platform Screw	69	4	Wheel Spacer
20	3	Hood Screw	70	2	Wheel
21	7	M4.2 x 13mm Screw	71	1	Front Roller/Pulley
22	1	Left Handrail	72	4	M8 Flat Washer
23	1	Upright Grommet	73	1	Access Door
24	1	Latch Pin Assembly	74	2	Frame Endcap
25	6	Foot Rail Screw	75	4	Long Foot Rail Screw
26	6	19mm Tek Screw	76	1	Walking Belt
27	2	Walking Platform Bolt	77	4	Handrail Endcap
28	4	Belt Guide Screw	78	2	Platform Cushion
29	2	Rear Roller Adj. Bolt	79	1	Drive Motor
30	2	Motor Bolt	80	3	Wire Tie
31	1	Motor Pivot Bolt	81	4	8" Tie
32	4	M6 Flat Washer	82	2	M8 x 52mm Bolt
33	1	Right Handrail	83	1	Reed Switch Clip
34	2	Motor Tension Bolt	84	2	Controller Screw
35	2	Wheel Bolt	85	2	16mm Screw
36	2	Rear Roller Star Washer	86	1	Walking Platform
37	1	Reset/Off Circuit Breaker	87	1	Controller
38	2	Motor Star Washer	88	1	Console Crossbar
39	1	Wire Harness	89	1	Reed Switch
40	2	Incline Pin	90	1	Power Cord
41	4	Belly Pan Screw	91	1	Console
42	4	Electronics Star Washer	92	1	Releasable Tie
43	4	M6 Nut	93	2	Belt Guide
44	6	Motor Tension Nut/Platform Nut	94	1	5mm Hex Key
45	2	Wheel Housing	95	2	Incline Leg
46	2	M8 Nut	96	2	U-nut
47	3	Hood Clip	97	2	Front Roller Washer
48	1	Latch Housing	98	2	Rear Cushion
49	1	Belly Pan Grommet	99	1	Power Cord Grommet
50	2	Isolator Fastener	100	1	Motor Pivot Nut

Key No.	Qty.	Description	Key No.	Qty.	Description
101	2	Rear Roller Flat Washer	*	–	4" Red Wire, M/F
*	–	4" White Wire, M/F	*	–	User's Manual
*	–	4" Blue Wire, 2F			

Note: Specifications are subject to change without notice. For information about ordering replacement parts, see the back cover of this manual. \*These parts are not illustrated.

# EXPLODED DRAWING A—Model No. WLTL29606.9

R0710A

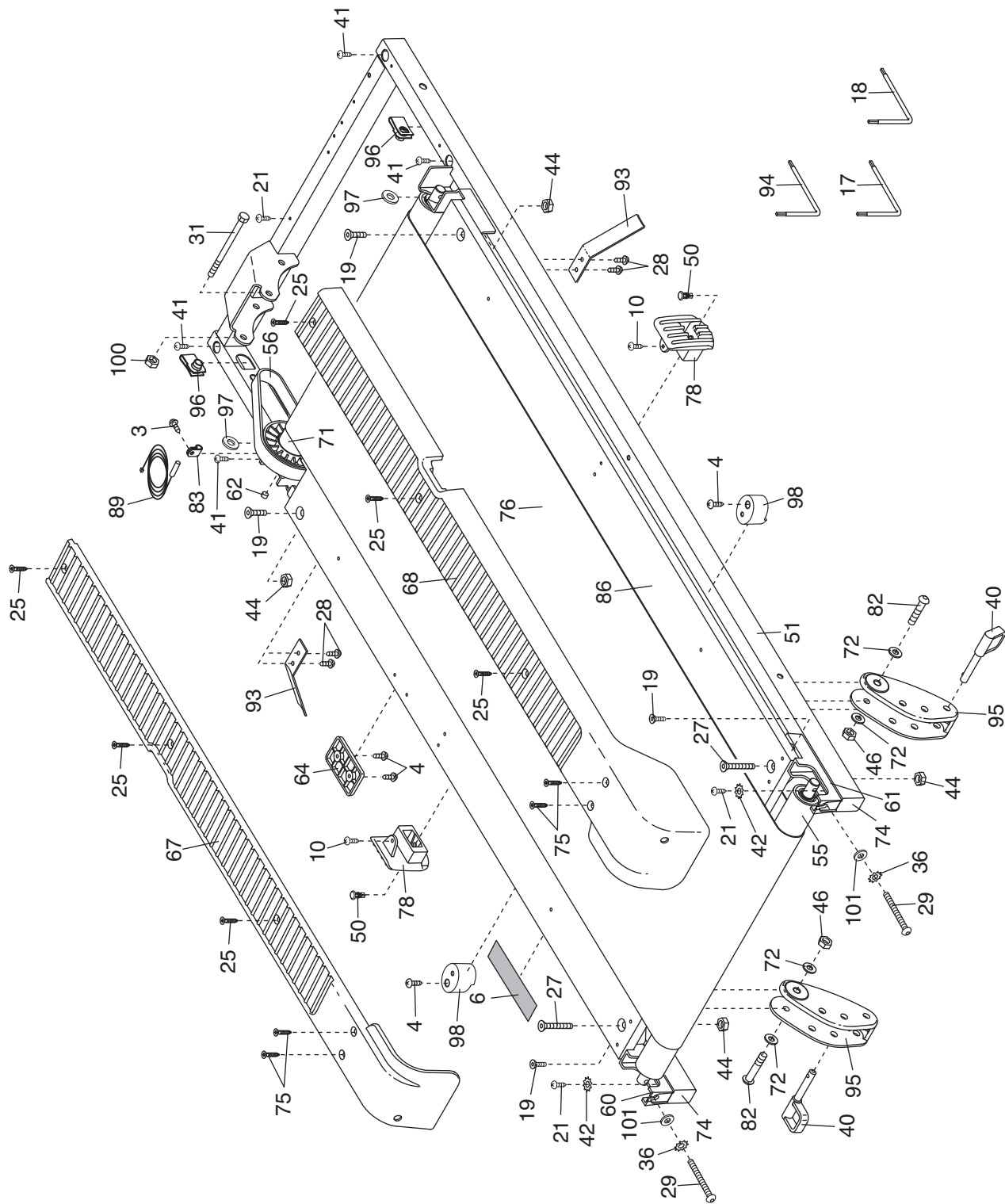



# EXPLODED DRAWING B—Model No. WLTL29606.9

R0710A

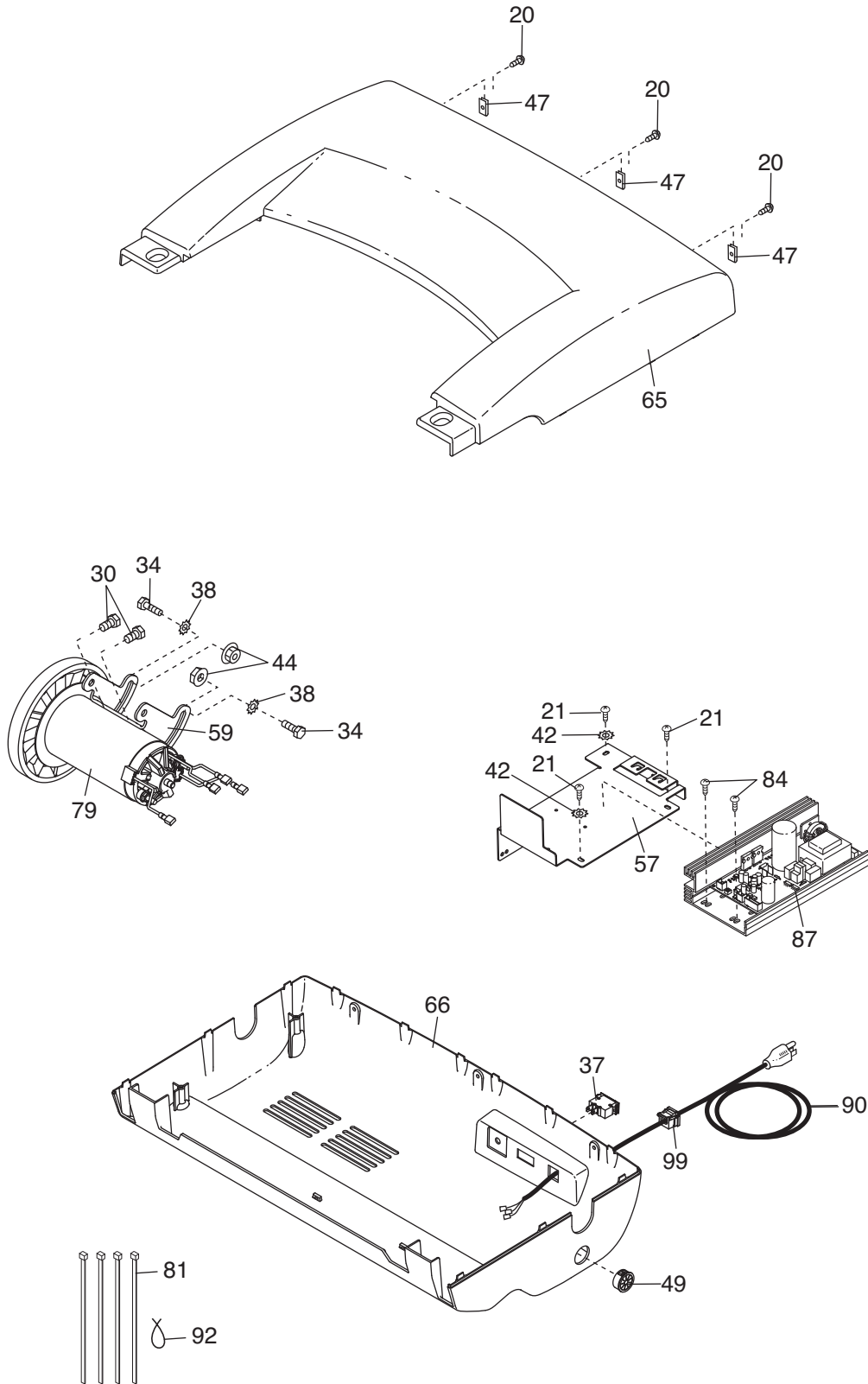

# EXPLODED DRAWING C—Model No. WLTL29606.9

R0710A

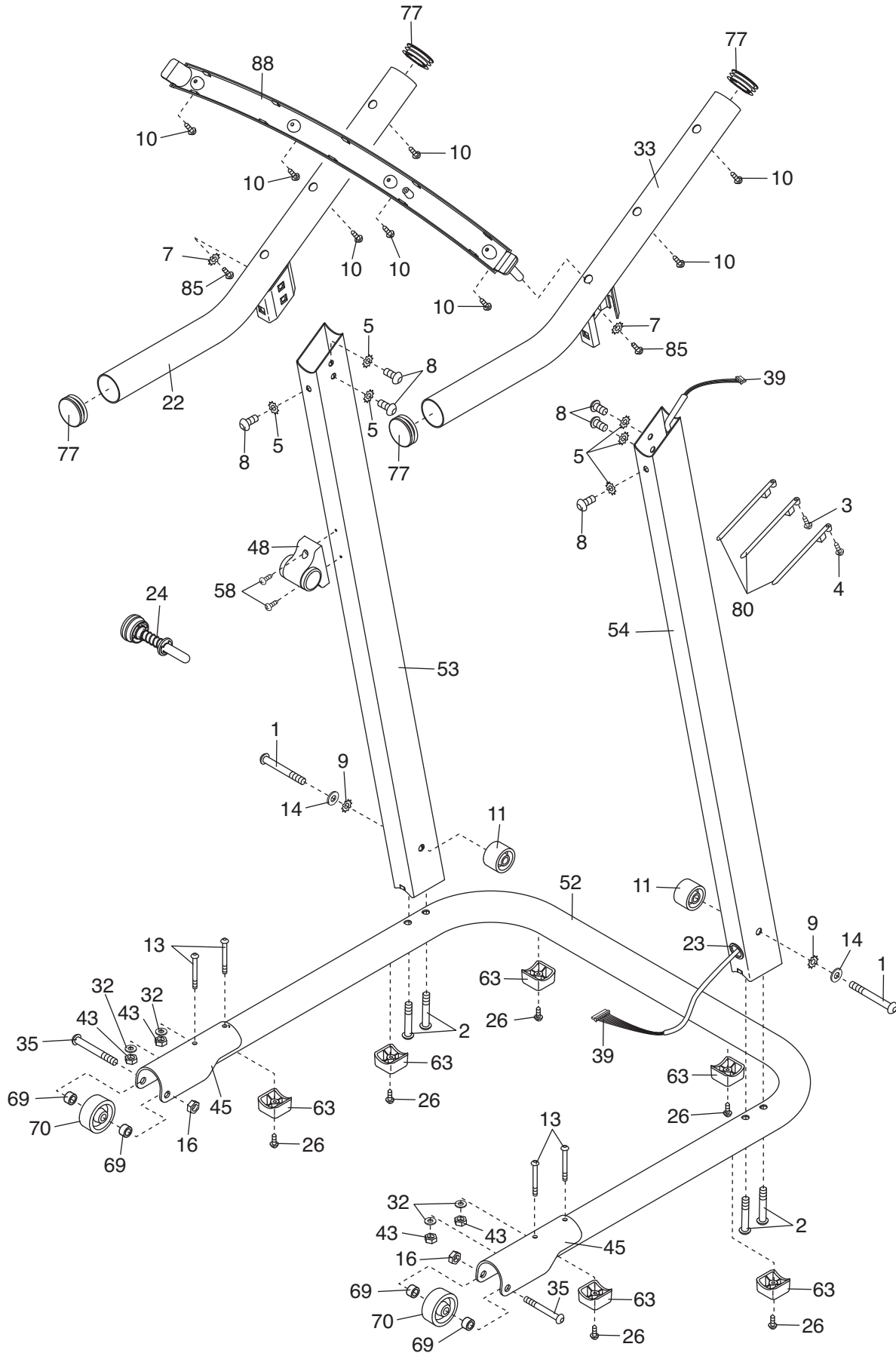

# EXPLODED DRAWING D—Model No. WLTL29606.9

R0710A

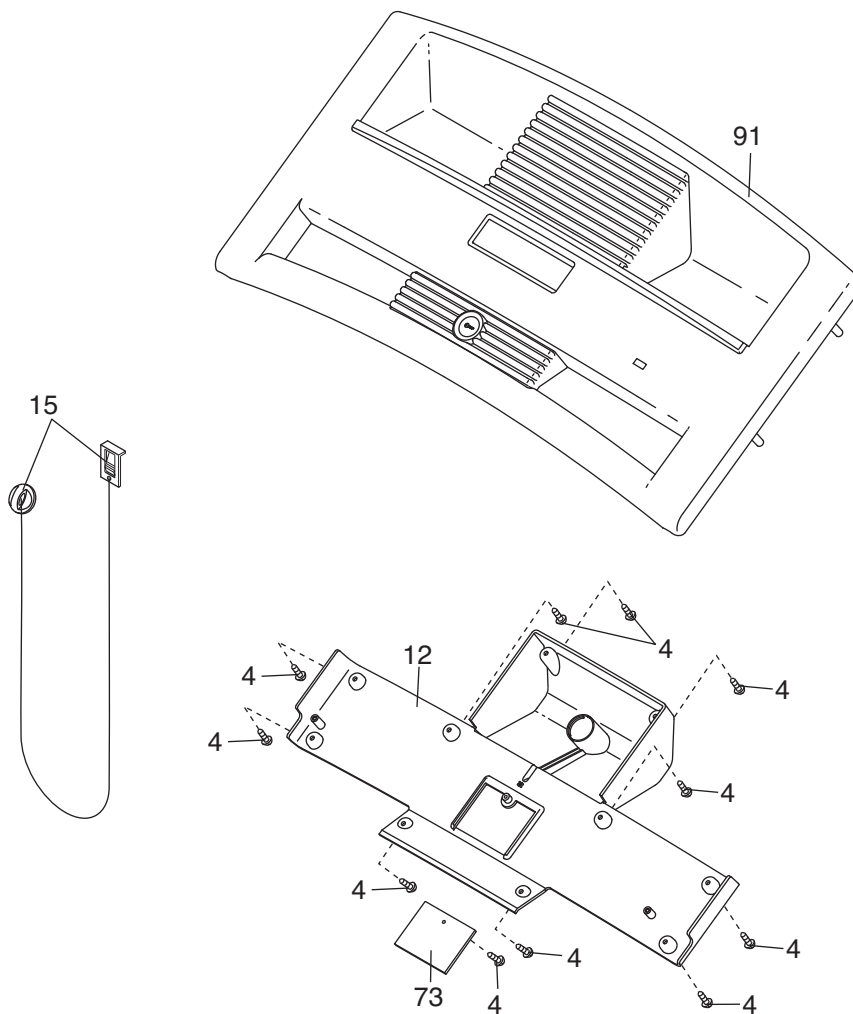

## ORDERING REPLACEMENT PARTS

To order replacement parts, please see the front cover of this manual. To help us assist you, be prepared to provide the following information when contacting us:

- the model number and serial number of the product (see the front cover of this manual)
- the name of the product (see the front cover of this manual)
- the key number and description of the replacement part(s) (see the PART LIST and the EXPLODED DRAWING near the end of this manual)

### LIMITED WARRANTY

**IMPORTANT: You must register this product within 30 days of the purchase date to avoid added fees for service needed under warranty. Go to [www.wesloservice.com/registration](http://www.wesloservice.com/registration).**

ICON Health & Fitness, Inc. (ICON) warrants this product to be free from defects in workmanship and material, under normal use and service conditions. The drive motor is warranted for one (1) year from the date of purchase. Parts and labor are warranted for ninety (90) days from the date of purchase.

This warranty extends only to the original purchaser. ICON's obligation under this warranty is limited to repairing or replacing, at ICON's option, the product through one of its authorized service centers. All repairs for which warranty claims are made must be preauthorized by ICON. If the product is shipped to a service center, freight charges to and from the service center will be the customer's responsibility. For replacement parts shipped while the product is under warranty, the customer will be responsible for a minimal handling charge. For in-home service, the customer will be responsible for a minimal trip charge. This warranty does not extend to any damage to a product caused by or attributable to freight damage, abuse, misuse, improper or abnormal usage, or repairs not provided by an ICON authorized service center; to products used for commercial or rental purposes or as store display models; or to products transported or purchased outside the US. No other warranty beyond that specifically set forth above is authorized by ICON.

ICON is not responsible or liable for indirect, special, or consequential damages arising out of or in connection with the use or performance of the product; damages with respect to any economic loss, loss of property, loss of revenues or profits, loss of enjoyment or use, or costs of removal or installation; or other consequential damages of whatsoever nature. Some states do not allow the exclusion or limitation of incidental or consequential damages. Accordingly, the above limitation may not apply to you.

The warranty extended hereunder is in lieu of any and all other warranties, and any implied warranties of merchantability or fitness for a particular purpose are limited in their scope and duration to the terms set forth herein. Some states do not allow limitations on how long an implied warranty lasts. Accordingly, the above limitation may not apply to you.

This warranty gives you specific legal rights. You may also have other rights that vary from state to state.

**ICON Health & Fitness, Inc., 1500 S. 1000 W., Logan, UT 84321-9813**