

PROPULSE III[®] UNIVERSAL

The fully portable electronic ear irrigator

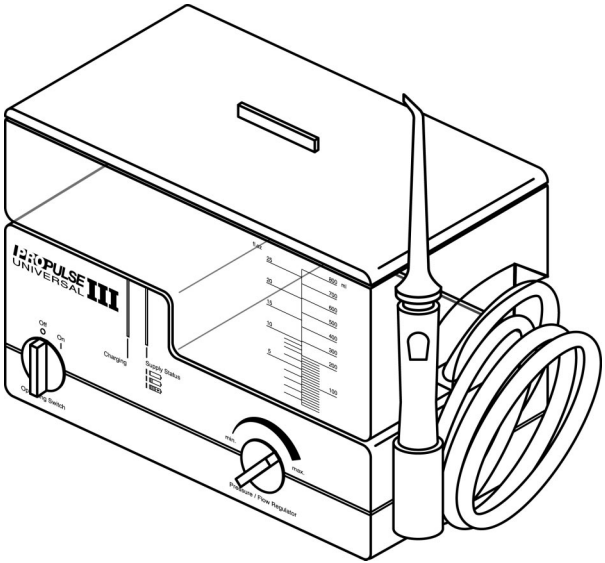

User Manual English Language Version

CE
0499

MIRAGE[®]
HEALTH GROUP

Professional Ear Care with Integrity

PROPULSE Instruments

Professional Ear Care with Integrity

Propulse Henckel style forceps 3"



Propulse Jobson Horne style probe 1.1mm

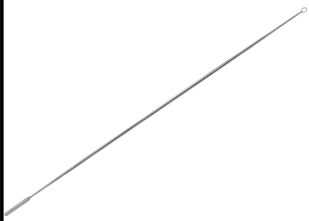

Propulse Wax Hook

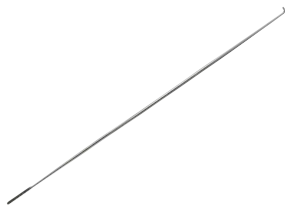

Propulse Hartmann style crocodile forceps



Propulse R/R dressing scissors



Noots Tank



Propulse Tilley style aural dressing forceps



PROPULSE Accessories

Professional Ear Care with Integrity

ENGLISH

Propulse Cleaning Tablets

Propulse Disposable "One Use" Jet Tips, packs of 100



Propulse Carry Case, makes domiciliary visits even simpler

Propulse Headlamp



Replacement Washers & Valves

Replacement Reservoir



INTENDED PURPOSE

The Propulse III Electronic Ear Irrigator is intended to:

- a) Facilitate the removal of cerumen and foreign bodies which are not hygroscopic, from the external auditory meatus.
- b) Remove discharge, keratin or debris from the external auditory meatus by irrigation with warm water.

Reasons for using this procedure are to:

- a) Correctly treat otitis externa where the meatus is obscured by debris.
- b) Improve conduction of sound into the ear, where impacted wax is believed to be the cause of a hearing defect.
- c) Examine the external auditory meatus and the tympanic membrane.
- d) Remove a cause of discomfort.

We recommend this procedure is only carried out by a suitably trained nurse, doctor or audiologist.

WARNINGS AND CAUTIONS

- This manual must be read and understood before the Propulse III is used.
- Only suitably trained staff should use the device.
- The Propulse Jet Tip is "One Use", dispose of after use.
- The Propulse III must not be immersed in water.
- Only clean the device as specified in this manual (See page 10).
- If any changes in performance occur disconnect from mains power, turn off the Propulse III and do **NOT** use (See page 11).
- The device has no user serviceable parts (See page 11).
- Do not use with other manufacturers accessories or consumables.
- Do not use Propulse Accessories with other devices.
- If the device is to be used for domestic visits it is strongly advised that the Propulse Carry Case is used to prevent damage and contamination.

- The Propulse III Electronic Ear Irrigator is not user repairable and should be returned to your Propulse supplier or the Mirage Service Department (UK customers only) for service and/or repair.

Please note: Damage caused to your Propulse III by the use of non Propulse accessories, consumables or service agents will invalidate your warranty.

- **DO NOT IRRIGATE** the ears if:
 - a) Consent is not given and/or the patient is uncooperative.
 - b) Previous complications occurred following this procedure.
 - c) There is a history of a middle ear infection in the last six weeks.
 - d) The patient has undergone ear surgery (apart from grommets that have extruded at least 18 months previously and the patient has been discharged from the ENT dept).
 - e) The patient has a perforation or there is a history of a mucous discharge in the last year.
 - f) The patient has a cleft palate (repaired or not).
 - g) In the presence of acute otitis externa; an oedematous ear canal combined with pain and tenderness of the pinna.
 - h) If patient complains of pain - **STOP IMMEDIATELY.**

DESCRIPTION

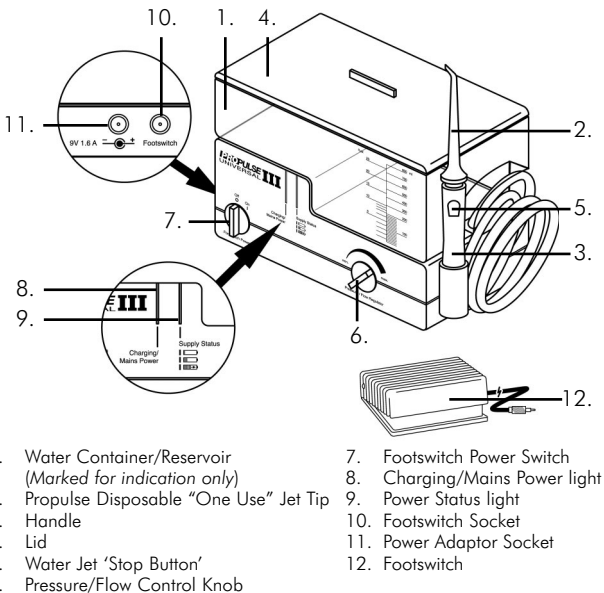

The Propulse III Electronic Ear Irrigator consists of:

- a) The main unit with integral battery, and User Controls:
- A Footswitch Power Switch (7) - this switch powers the equipment on (I) and off (O) in conjunction with the footswitch. (See 'd' below).
 - A water pressure/flow control knob (6)
 - A water jet stop button (5) on the handle (See 'c' below).
 - Charging/Mains Power Light (8) illuminates green when connected to mains power by the Power Adaptor.
 - Power Status Light (9) illuminates when the Propulse is turned on.

Note: The tricolour light merges from one colour to the next.

Green: *when there is adequate power from battery or mains.*

Amber: *battery power level is low and will need to be recharged soon.*

Red: *connect to mains via the Power Adaptor. Battery needs recharging immediately.*

- b) Water container/reservoir (1) is removable for filling and cleaning. Graduations are for indication only.
- c) Handle (3) and non-detachable hose. The handle accommodates Propulse Disposable "One Use" Jet Tips.
The handle incorporates a water jet stop button (5). This button will stop the flow of water when it is pressed and held fully in. The flow of water will resume on release of the button, providing the footswitch is pressed.
- d) The footswitch (12) - is connected to the main body via a jackplug/socket connection (10). The device will only function if the footswitch is connected,
Pressing the footswitch causes the device to pump water through the Propulse Disposable "One Use" Jet Tip at the pressure/flow set by the pressure/flow control knob (6).

TECHNICAL DATA

Performance:

Static Pressure	
Minimum setting	0.27-1.1 bar
Maximum setting	1.35-3.45 bar
Water jet pulses	1200 per minute approximately
Maximum operating time	10 minutes continuous use (with a recommended rest time of 2 hours)
Storage temperature range	-5°C to 65°C
Storage relative humidity	Up to 80%
Rechargeable Battery	6v Ni-MH 1300 mAh
Power Adaptor	Input 100-240v ~50/60Hz Max 0.48A Output 9V DC 1.5A
Electrical Safety	EN60601-1
EMC Compliance	EN 60601-1-2

GUIDE TO SYMBOLS:



Class IIa Equipment



Type BF Electrical safety



Attention Consult Accompanying Documents

IPX1 Protected against water droplets



Single use item



Conforms to the Medical Device Directive
93/42/EEC



Must be disposed of in accordance with
European waste electrical and electronic
equipment directive 2002/96/EC

OPERATING INSTRUCTIONS

These instructions are for general use. When required refer to Detailed Information in the second half of this manual.

- Ensure that the device is **ONLY** used by suitably trained clinicians
- Ensure that the warnings and cautions are observed
- Ensure that the patient exhibits no contra indications

- Ensure the unit has been cleaned
- Mains electrical power is not necessary if the battery is adequately charged
- The device may be run connected to the mains electrical supply by the power supply provided
- Connect the footswitch provided
- The reservoir should be removed to fill
- Fill the reservoir to a maximum of 700ml with warm water at 40°C. Check regularly to ensure temperature drop does not occur. Refill as necessary.
- Fit a new Propulse Disposable "One Use" Jet Tip to the handle
- Set Pressure/flow to minimum
- Turn on the Footswitch Power Switch (7) to on, marked "1"
- With the footswitch depressed check that the power status (9) is adequate, green. If the power status is not adequate, amber or red indicator, the Propulse III may be run connected to the mains electrical supply by the Power Adaptor provided.
- Adjust the water pressure/flow to appropriate value compatible with the treatment requirements and patient comfort.
- Direct the irrigator tip into the noots tank and switch on the machine for 10-20 seconds in order to circulate the water through the system and eliminate any trapped air or cold water. Ensure water is warm before presentation to the patient.
- During treatment you can pause the flow by releasing the footswitch or pressing and holding the Water Stop button on the handle(5).
- After treatment empty the reservoir and operate the device to purge residual water.
- Remove the Propulse Disposable "One Use" Jet Tip and dispose of to clinical waste.
- Turn off Footswitch Power Switch (7) after use and connect to Power Adaptor to recharge the battery if required.
- Clean the Propulse III unit every morning prior to use with a cleaning tablet (See page 10).
- The Propulse III should only be transported in a Propulse approved Carry Case to prevent damage or contamination.
- If any changes in the performance of the Propulse III occur it should be disconnected from mains power and should **NOT** be used. Please refer the machine to the Mirage Service Department (See page 11).

DETAILED INFORMATION

Fitting the Footswitch

The Propulse footswitch is connected to the main unit by a socket (10) in the side of the device. The Propulse III Universal ear irrigator will **NOT** operate unless the footswitch is connected.

Filling the water container

It is recommended that:

- i) The water container/reservoir (1) is removed from the device for filling and that the lid is always in place when the water container is in-situ on the device.
- ii) The water reservoir must **NOT** be filled over the 700ml marking to eliminate the risk of spillage. (The graduations marked on the reservoir are for indication only).
- iii) Water above 40°C should **NOT** be used in order to avoid the risk of scalding and burns to the user and patient. Water below 40°C should **NOT** be used in order to avoid the risk of patient discomfort and dizziness.

Fitting the Propulse Disposable "One Use" Jet Tip applicators

The Propulse III Electronic Ear Irrigator is supplied with ten Propulse Disposable "One Use" Jet Tip applicators. Use one Propulse Disposable "One Use" Jet Tip per treatment.

To fit a Jet Tip applicator push the Jet Tip applicator directly into the handle, without using a sideways movement.

To remove a Jet Tip applicator pull the jet tip applicator directly from the handle, without using a sideways movement.

Propulse Disposable "One Use" Jet Tips are available in boxes of 100 individually wrapped tips from your normal Propulse supplier or from from Mirage direct (UK only). Propulse Disposable "One Use" Jet Tips are clearly branded with the Propulse logo on the tip and it's packaging. Only Propulse branded Disposable "One Use" Jet Tips should be used with the Propulse III Ear Irrigator.

Power Adaptor

The Power Adaptor can be used to charge the internal battery or to run the device from the mains electrical supply.

Connect the outlet lead of the Power Adaptor to the Power Adaptor socket (11) marked on the end of the product and to the mains electrical supply. Make sure the cord and Power Adaptor are positioned so that they will not be subjected to damage or stress or present a trip hazard.

Only use a Propulse III branded Power Adaptor.

To reduce the risk of electric shock, unplug the unit from the power source before attempting to clean it externally.

The Power Adaptor must not be used outdoors or in damp areas.

The Propulse III Power Adaptor will have been supplied with an appropriate electrical plug. If there are any problems connecting to the mains electrical supply consult a qualified electrician.

Battery Use And Care

We recommend that the battery is fully charged for 24 hours before you use the Propulse III for the first time.

For subsequent use the battery will normally require 16 hours to fully charge.

A new battery or one that has not been used for a long time could have reduced capacity the first few times it is used.

The battery is integral and is only replaceable by a Mirage authorised battery replacement centre. Refer to your Propulse supplier or the Mirage Service Department (UK customers only). It is recommended that the battery is replaced after 400 charge cycles.

Environmental Protection



This symbol on the products and/or accompanying documents means that use electrical and electronic products should not be mixed with general waste.

Please return to Mirage Health Group. Penalties may be applicable for incorrect disposal of this waste, in accordance with national legislation.

Disposing of used Propulse Disposable 'One-Use' Jet Tip - Disposal should be in accordance with local regulations and guidelines for the disposal of clinical waste. Propulse Disposable 'One-Use' Jet Tips should not be placed in municipal waste.

Transportation

Before the Propulse III is transported the reservoir must be emptied and the machine should be run until the handle and hose are empty of liquid. The reservoir should then be dried using a paper towel.

The Propulse III should only be transported in a Propulse approved Carry Case to prevent damage or contamination.

Cleaning

Do not attempt to clean the Jet Tip. Use one Propulse Disposable "One Use" Jet Tip per patient treatment and discard to clinical waste after use as this reduces the risk of cross infection between patients.

External cleaning should be done by hand, wiping with a damp cloth only. Apply liquids to the cloth not the unit. Do not immerse the unit in water. Mild detergents and disinfectants may be used externally.

Internal cleaning of the Propulse III Electronic Ear Irrigator pumps and waterways PRIOR to use:

1. Place one Propulse cleaning tablet into the reservoir, fill with warm water to the 500ml mark on the reservoir and wait for tablet to completely dissolve.
2. Run the Propulse III Electronic Ear Irrigator for a few seconds to fill the pump and hose.
3. Leave to stand for 10 minutes.
4. Empty the reservoir of the solution, then fill the reservoir with cool boiled water or well run cold tap water and flush through the whole system to ensure no cleaning solution is left.
5. This cleaning procedure should be used prior to each days usage of the ear irrigator.
6. **DO NOT** leave the solution in the unit for longer than stated.

Cleaning Tablets for the Propulse III Electronic Ear Irrigator - the importance of using the correct strength cleaning solution cannot be overstated. A solution that is too strong will in time damage the Propulse and one that is too weak will fail to provide the correct level of cleaning and decontamination. To this end the manufacturer has introduced a simple to use, effective specific strength CHLOR-CLEAN™ decontamination tablet. Propulse cleaning tablets are available from your normal Propulse supplier or direct from Mirage (UK only).

Please note: Damage caused to your Propulse III ear irrigator by not using the recommended cleaning agent will invalidate your warranty.

Other instruments used with Propulse III should be cleaned according to local guidelines.

Maintenance & Safety Inspections

To ensure optimum performance the Propulse III Electronic Ear Irrigator should be serviced every 12 months. Service or repairs conducted by unauthorised agencies/organisations invalidate any or implied warranties from Mirage.

The Propulse III should under-go routine electrical safety testing to ensure that it remains safe to use.

Users of the Propulse III should carry out regular inspections to ensure that the handle and hose, Power Adaptor and cable, reservoir and main body of the machine are free from damage prior to use. If any damage is evident the Propulse III should **NOT** be used until replacement parts have been fitted. Only Propulse branded items should be used with the Propulse III.

The Propulse III Electronic Ear Irrigator is not user repairable and should be returned to your Propulse supplier or the Mirage Service Department (UK customers only) for service and/or repair:

MIRAGE SERVICE DEPARTMENT

53 Purbeck Drive, Lostock, Bolton, Lancashire BL6 4JF
Tel: 0845 130 5445

The clinical procedures relating to the use of ear irrigators can be found on the following websites:

www.earcarecentre.com

www.entnursing.com/earcare.htm

Mirage is not responsible for the content or maintenance of third party internet sites.

Mirage can also advise on the availability of training courses offered by the relevant organisations.

Warranty

The manufacturer cannot accept responsibility if the Propulse III is used for any purpose other than that intended by the manufacturer.

The manufacturer cannot accept responsibility for damage or injury, however caused, through the use of non-approved jet tip applicators.

Additional user manuals and other accessories are available from Mirage Health Group Ltd at:

MIRAGE HEALTH GROUP Ltd

BioPark Hertfordshire, Broadwater Road, Welwyn Garden City, Hertfordshire. AL7 3AX UK
Tel: 0845 130 5440

Manufactured By

MIRAGE HEALTH GROUP Ltd

BioPark Hertfordshire, Broadwater Road, Welwyn Garden City, Hertfordshire. AL7 3AX UK
Tel: 0845 130 5440

EAR CARE TRAINING (UK only)

Mirage can advise on the availability of training courses offered by relevant organisations.

Mirage Health Group Ltd

BioPark Hertfordshire, Broadwater Road,
Welwyn Garden City, Hertfordshire.
AL7 3AX UK

Tel: 0845 130 5440 Fax: 0845 130 6440

Overseas Tel: +44 845 130 5440 Fax: +44 845 130 6440

www.miragehealthgroup.com

uksales@miragehealthgroup.com

internationalsales@miragehealthgroup.com

CE
0499

MIRAGE
HEALTH GROUP

Copyright Mirage Health Group Ltd

September 2006