



LinkRunner™ AT 1000/2000

Network Auto-Tester

Users Manual

January 2012
© 2012 Fluke Corporation.
All product names are trademarks of their respective companies.

LIMITED WARRANTY AND LIMITATION OF LIABILITY

Each Fluke Networks product is warranted to be free from defects in material and workmanship under normal use and service. The warranty period for the mainframe is one year and begins on the date of purchase. Parts, accessories, product repairs and services are warranted for 90 days, unless otherwise stated. Ni-Cad, Ni-MH and Li-Ion batteries, cables or other peripherals are all considered parts or accessories. The warranty extends only to the original buyer or end user customer of a Fluke Networks authorized reseller, and does not apply to any product which, in Fluke Networks' opinion, has been misused, abused, altered, neglected, contaminated, or damaged by accident or abnormal conditions of operation or handling. Fluke Networks warrants that software will operate substantially in accordance with its functional specifications for 90 days and that it has been properly recorded on non-defective media. Fluke Networks does not warrant that software will be error free or operate without interruption.

Fluke Networks authorized resellers shall extend this warranty on new and unused products to end-user customers only but have no authority to extend a greater or different warranty on behalf of Fluke Networks. Warranty support is available only if product is purchased through a Fluke Networks authorized sales outlet or Buyer has paid the applicable international price. Fluke Networks reserves the right to invoice Buyer for importation costs of repair/replacement parts when product purchased in one country is submitted for repair in another country.

Fluke Networks warranty obligation is limited, at Fluke Networks option, to refund of the purchase price, free of charge repair, or replacement of a defective product which is returned to a Fluke Networks authorized service center within the warranty period.

To obtain warranty service, contact your nearest Fluke Networks authorized service center to obtain return authorization information, then send the product to that service center, with a description of the difficulty, postage and insurance prepaid (FOB destination). Fluke Networks assumes no risk for damage in transit. Following warranty repair, the product will be returned to Buyer, transportation prepaid (FOB destination). If Fluke Networks determines that failure was caused by neglect, misuse, contamination, alteration, accident or abnormal condition of operation or handling, or normal wear and tear of mechanical components, Fluke Networks will provide an estimate of repair costs and obtain authorization before commencing the work. Following repair, the product will be returned to the Buyer transportation prepaid and the Buyer will be billed for the repair and return transportation charges (FOB Shipping point).

THIS WARRANTY IS BUYER'S SOLE AND EXCLUSIVE REMEDY AND IS IN LIEU OF ALL OTHER WARRANTIES, EXPRESS OR IMPLIED, INCLUDING BUT NOT LIMITED TO ANY IMPLIED WARRANTY OR MERCHANTABILITY OR FITNESS FOR A PARTICULAR PURPOSE. FLUKE NETWORKS SHALL NOT BE LIABLE FOR ANY SPECIAL, INDIRECT, INCIDENTAL OR CONSEQUENTIAL DAMAGES OR LOSSES, INCLUDING LOSS OF DATA, ARISING FROM ANY CAUSE OR THEORY.

Since some countries or states do not allow limitation of the term of an implied warranty, or exclusion or limitation of incidental or consequential damages, the limitations and exclusions of this warranty may not apply to every buyer. If any provision of this Warranty is held invalid or unenforceable by a court or other decision-maker of competent jurisdiction, such holding will not affect the validity or enforceability of any other provision.

SOFTWARE NOTICE

This product uses freeRTOS v6.0.5 software. For more information on freeRTOS, go to <http://www.freertos.org>. The software license statement and files that contain the binary and source code for freeRTOS v6.0.5 are on the LinkRunner AT CD supplied with this product.

Copyright © 2010 Real Time Engineering Ltd.

Copyright © 1998 Regents of the University of California. All rights reserved.

Redistribution and use in source and binary forms, with or without modification, are permitted provided that the following conditions are met:

Redistributions of source code must retain the above copyright notice, this list of conditions and the following disclaimer.

Redistributions in binary form must reproduce the above copyright notice, this list of conditions and the following disclaimer in the documentation and/or other materials provided with the distribution.

Neither the name of the University of California, Berkeley nor the names of its contributors may be used to endorse or promote products derived from this software without specific prior written permission.

THIS SOFTWARE IS PROVIDED BY THE COPYRIGHT HOLDERS AND CONTRIBUTORS "AS IS" AND ANY EXPRESS OR IMPLIED WARRANTIES, INCLUDING, BUT NOT LIMITED TO, THE IMPLIED WARRANTIES OF MERCHANTABILITY AND FITNESS FOR A PARTICULAR PURPOSE ARE DISCLAIMED. IN NO EVENT SHALL THE COPYRIGHT HOLDER OR CONTRIBUTORS BE LIABLE FOR ANY DIRECT, INDIRECT, INCIDENTAL, SPECIAL, EXEMPLARY, OR CONSEQUENTIAL DAMAGES (INCLUDING, BUT NOT LIMITED TO, PROCUREMENT OF SUBSTITUTE GOODS OR SERVICES; LOSS OF USE, DATA, OR PROFITS; OR BUSINESS INTERRUPTION) HOWEVER CAUSED AND ON ANY THEORY OF LIABILITY, WHETHER IN CONTRACT, STRICT LIABILITY, OR TORT (INCLUDING NEGLIGENCE OR OTHERWISE) ARISING IN ANY WAY OUT OF THE USE OF THIS SOFTWARE, EVEN IF ADVISED OF THE POSSIBILITY OF SUCH DAMAGE.

Contents

Title	Page
Introduction	1
Registering Your Product	1
The Fluke Networks Knowledge Base	1
Contact Fluke Networks	2
Safety Information	2
Unpacking	3
LR-AT (1000 and 2000 Models)	3
Cleaning the Tester	3
Physical Features	4
The Home Screen	6
Battery Charging and Life	7
Common Questions LR-AT Can Solve	8
Saving a Report	10
Set Up the Tester	11
IP Configuration	11
VLAN/MAC Configuration	12

AutoTest Configuration	12
PoE Configuration	13
Connect Configuration	13
General Configuration	14
Reflector Configuration (LR-AT 2000 Model)	14
LinkRunner Information	15
Manage Files	16
Restore Factory Defaults	17
Firmware Update	18
Transfer Saved Profiles to/from LinkRunner Manager	19
Set Language	19
Using AutoTest, Switch, and Cable Test	19
Using AutoTest	19
Using the Nearest Switch Test	21
Using the Cable Test	21
Using PoE Feature	22
Using the Reflector Feature (LR-AT 2000 only)	23
Using the Fiber Connection	23
Maintenance	24
Options and Accessories	25
Specifications	26
Environmental Specifications	26
General Specifications	27
LinkRunner Manager Software	28

List of Figures

Figure		Page
1.	Physical Features	4
2.	The Home Screen	6
3.	How to Remove the Battery.....	7
4.	Tools Menu.....	11
5.	IP Configuration Screen.....	11
6.	VLAN/MAC Configuration Screen	12
7.	AutoTest Configuration Screen.....	12
8.	PoE Configuration Screen.....	13
9.	Connect Configuration Screen	13
10.	General Configuration Screen.....	14
11.	Reflector Settings Screen	14
12.	Reflector Default Configuration Screen	15
13.	LinkRunner Information Screen	16
14.	AutoTest Configuration Screen.....	20
15.	AutoTest Results Screen.....	20
16.	Expanding Test Results	20
17.	Nearest Switch Results	21

18.	Cable Test Results	21
19.	TruePower™ Disabled PoE AutoTest Results	22
20.	TruePower™ Disabled PoE Switch Results	22
21.	TruePower™ Enabled PoE AutoTest Results	23
22.	TruePower™ Enabled PoE Switch Results	23
23.	Fiber Connected Switch Results.....	24

LinkRunner AT 1000/2000 Network Auto-Tester

Introduction

LinkRunner AT 1000/2000 Network Auto-Tester enables you to quickly verify Ethernet copper and fiber (2000 model only) cables, network connectivity and availability. In addition, the tester can be used for identifying the network device to which it is connected. It identifies PoE ports, provides a Report generating function, and can serve as a packet reflector for Fluke Networks performance tests. You can also transfer and view reports on LinkRunner Manager.

LinkRunner AT 1000/2000 Network Auto-Tester is hereafter referred to as the LR-AT.

Registering Your Product

Registering your product with Fluke Networks gives you access to valuable information on product updates, troubleshooting procedures, and other services. To register, fill out the online form on the Fluke Networks website at www.flukenetworks.com/registration.

The Fluke Networks Knowledge Base

The Fluke Networks Knowledge Base gives answers to common questions about Fluke Networks products and includes information on technology and procedures for network and cable tests. To see the Knowledge Base, go to www.flukenetworks.com, then click **Support > Knowledge Base**.

Contact Fluke Networks

-  www.flukenetworks.com
-  support@flukenetworks.com
-  +1-425-446-4519







- Australia: 61 (2) 8850-3333 or 61 (3) 9329 0244
- Beijing: 86 (10) 6512-3435
- Brazil: 11 3759 7600
- Canada: 1-800-363-5853
- Europe: +31-(0) 40 2675 600
- Hong Kong: 852 2721-3228
- Japan: 03-6714-3117
- Korea: 82 2 539-6311
- Singapore: +65-6799-5566
- Taiwan: (886) 2-227-83199
- USA: 1-800-283-5853

For more phone numbers, go to our website.

Safety Information

Table 1 gives descriptions of the safety symbols used on the tester and in this manual.

Table 1. Safety Symbols

	NOT FOR CONNECTION TO PUBLIC TELEPHONE SYSTEMS
	Warning or Caution: risk of damage to or destruction of equipment or software. See explanations in the manual.
	CANADIAN STANDARDS ASSOCIATION CERTIFIED TO CANADIAN AND US STANDARDS
	Meets Australia EMC Requirements.
	CLASS 1 LASER PRODUCT. DO NOT LOOK INTO LASER
	Warning: Risk of electrical shock.
	Do not put products that contain circuit boards into waste containers. Refer to local regulations for disposal procedures.

Warning

Use only the ac adapter provided to charge the battery.

Warnings

To avoid possible electric shock or personal injury, follow these guidelines:

- Do not use this product if it is damaged. Before using the product, inspect the case. Look for cracked or missing plastic.
- Do not operate the product around explosive gas, vapor or dust.
- No serviceable parts.
- Do not try to service.
- If this product is used in a manner not specified by the manufacturer, the protection provided by the product may be impaired.

Warning Class 1 Laser Product

With an optional SFP fiber adapter installed, this product will contain a Class 1 laser. Do not look into the laser port because this may cause eye injury.

Cautions

Use the proper terminals and cable for all connections.

Unpacking

The LinkRunner AT tester comes with the accessories in the list below. If something is damaged or missing, tell the dealer where you purchased the product.

LR-AT (1000 and 2000 Models)

- LinkRunner with rechargeable battery pack
- AC adapter
- USB cable
- Carrying case
- Startup sheet
- LinkRunner Manager Software and Manuals CD
- WireView™ Office Locator #1 (LR-AT 2000 only)

Cleaning the Tester

To clean the display, use lens cleaner and a soft, lint-free cloth. To clean the case, use a soft cloth that is moist with water or a weak soap.

Caution

To prevent damage to the display or the case, do not use solvents or abrasive materials.

Physical Features

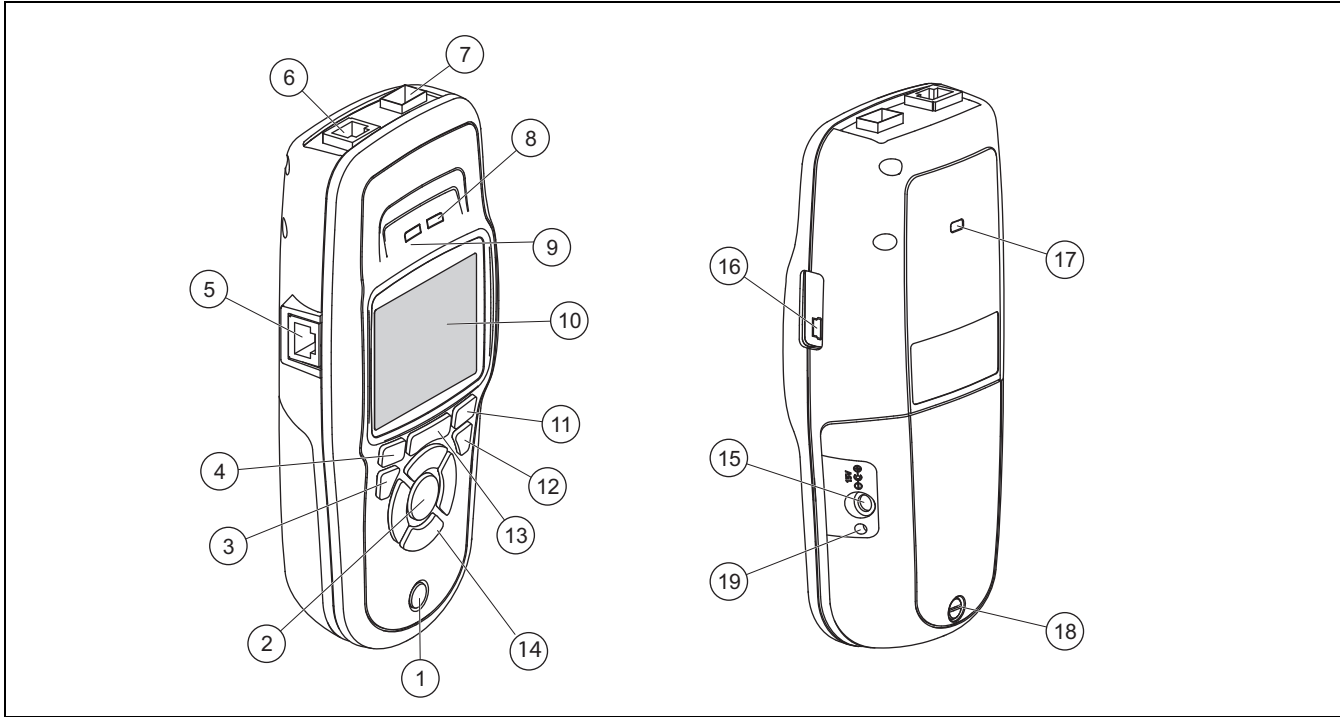



Figure 1. Physical Features

ffy01.eps

- ① On/off key.
- ② Makes a selection on the screen.
- ③ Shows the previous screen.
- ④ Softkeys. The function of the softkey is shown above the key.
- ⑤ Cable test wire mapping input. Connect the cable from the top Ethernet port to this port to view the wire map details.
- ⑥ Ethernet 10/100/1000BASE-X port.
- ⑦ Fiber port. Use one of the many supported SFP adapters to connect to the network.
- ⑧ Tx/Rx - The LED blinks when the tester transmits and receives data.
- ⑨ The LED is on when the tester is linked to the network.
- ⑩ Full-color LCD.
- ⑪ Softkeys. The function of the softkey is shown above the key.
- ⑫ Shows the Home screen.
- ⑬ : Clears the current measurement data. : Saves the current measurements data into a report file which can be transferred to the LinkRunner Manager PC application and viewed/printed.
- ⑭ Navigation keys. The outer ring of keys (four) perform the left/right and up/down screen navigation.
- ⑮ Connector for the ac adapter.
- ⑯ USB port for connection to a PC.
- ⑰ Kensington lock slot.
- ⑱ Screw for the battery pack.
- ⑲ The LED turns on when you connect the ac adapter. The LED is red when the battery is charging and green when the battery is fully charged.

The Home Screen

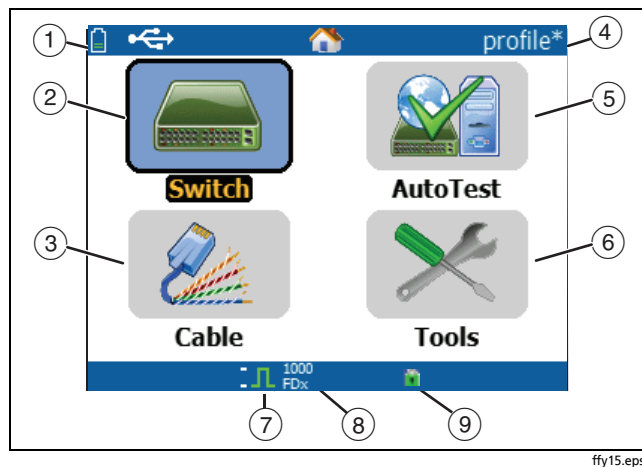





Figure 2. The Home Screen

- ①  Shows the battery status. When the battery charge is low, the icon blinks. Connect the ac adapter to charge the battery and to make sure the tester continues to operate.
-  Shows that the ac adapter is connected.
-  Shows that the USB interface is connected.

- ② **Switch:** Shows the advertised and actual link, PoE measurements, nearest switch with its name, type, IP address, port, slot, and VLAN information.
- ③ **Cable:** When the cable is connected un-terminated or is connected to a WireView™ Office Locator, it shows cable information or wire mapping information. This can also be used to locate a cable with the optional IntelliTone™ probe.
- ④ The name of the tester profile. A profile contains the tester configuration settings. The default name is "Untitled". The name shows an asterisk to the right of the name if you have changed a setting on the tester since you loaded or saved the profile.
- ⑤ **AutoTest:** Use Autotest to Ping and connect to selected targets. Up to 10 targets can be entered as a URL or IPv4/IPv6 address along with the optional port number. When no port is specified, a Ping is performed. When the port is specified, a TCP SYN/ACK is performed. This is also referred to as a TCP Connectivity test.
- ⑥ **Tools** lets you manage files and settings.
- ⑦ Link established indicator.
- ⑧ Displays the link speed and duplex mode.

- ⑨ Displays the connection type: PoE ⚡, 802.1x 🔒, fiber 🌟. For 802.1x, a green lock indicates authentication passed, yellow indicates it is not needed, and a red closed lock indicates it failed authentication.

Battery Charging and Life

To charge the battery, connect the ac adapter to the battery connector (see Figure 1). You can use the tester while you charge the battery.

Figure 3 shows how to replace the battery.

When the tester is off, the battery charges in approximately 3 hours.

Note

The battery will not charge if the internal temperature of the tester is above 113°F (45°C).

The battery life is approximately 6 hours during typical operation. An icon in the upper-left corner of the screen shows the battery status.

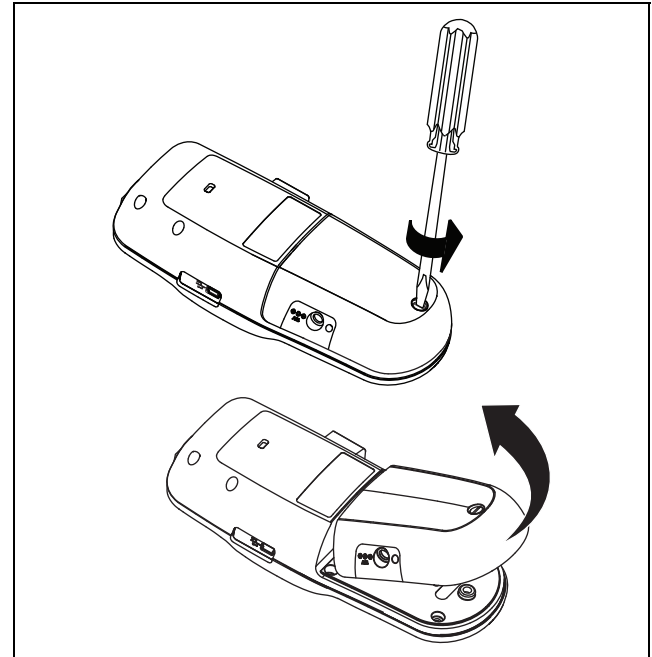

Figure 3. How to Remove the Battery

ffy14.eps

Common Questions LR-AT Can Solve

First connect an RJ-45 or fiber cable (2000 model only) from the network hub or wall plate to the LinkRunner AT RJ-45 LAN or fiber port. Check the following list of questions and associated answers to see how LinkRunner AT can help you get the job done.

Common Questions

Q > Is this a good RJ45 Ethernet cable?

A > Use **Cable** testing and the built in wiremap for patch cables, or an external Wireview™ Office Locator.

Q > Am I receiving a good fiber signal?

A > Connect to your network via a SFP adapter and validate the signal strength and link in the **Switch** screen.

Q > Where does this RJ45 cable go?

A > Use the **Cable** test toner function, **Switch > Flash Port** function, or **Switch** discovery protocol.

Q > Is this cable hooked up to anything?

A > Select **Switch** to identify an open cable, an active link, an un-powered network device or telephone voltage.

Q > Does this RJ45 drop support PoE?

A > Use **Tools** to specify the desired PoE power class and use **Switch** or **AutoTest** to verify the power under load up to 25.5W (802.3at).

Q > What speed/duplex is this device configured for?

A > Use **Switch** to check the advertised and actual speed/duplex. Additionally, use **Tools** to tests for manual (non-Auto Negotiated) speed/duplex.

Q > Can I see traffic from this connection?

A > Observe the utilization LED blinking to see network traffic.

Q> Can I connect in a MAC access control environment?

A> Use **Tools > VLAN/MAC** to specify a user defined MAC address.

Q > Do I have network connectivity?

A > Select **AutoTest** to validate key network services (DHCP, DNS, Router).

Q > Can I get an IPv4 DHCP address?

A > Select **AutoTest**. Select **DHCP** (or enter a static IP address) in the **Tools > IP Configuration** menu.

Q> Can I get an IPv6 address?

A > Enable IPv6 in **Tools > IP Configuration**. Use **AutoTest** to observe the acquired IPv6 link-local and global address.

Q > Can I PING?

A > Select **AutoTest**. Configure an address to Ping under **Tools > AutoTest Configuration**.

Q> Can I verify application connectivity?

A > Select **AutoTest**. Configure an address and application port (e.g. port 80 for web/HTTP) under **Tools > AutoTest Configuration**.

Q > Can I use it for throughput testing?

A> Use the **Reflector** tool (setup under **Tools** - only available on LR-AT 2000 model).

Q > Can I connect to an 802.1X port?

A > Use the **Tools > Connect Configuration** screen to enable 802.1X. Also, use the LinkRunner Manager PC application (select **Tools > General Information** to enable 802.1X and set up security).

Saving a Report







You can save the current measurement data the tester has collected into a report that can be viewed and printed through the LinkRunner Manager PC application. This information includes:

- AutoTest results
- Switch results
- Cable test results

Note







*The LR-AT 1000 model can save up to 10 reports.
The LR-AT 2000 model can save up to 50 reports.*

To save the measurement data collected on the tester:

- 1 Press . The tester shows a default filename at the bottom of the screen.
 - To save the data with the filename shown, press  **Save**. The tester saves the data into a report file.
 - To overwrite a report that is saved on the tester, highlight the report, press , press  **Save**, then press  **OK**.
 - To change the filename, press  **Edit**.

Note

Report names can have a maximum of 12 characters. The extension LRS is appended when the file is saved to your PC through the LinkRunner Manager PC application.

- To delete characters in the filename, press  **Backspace**.
- To add characters to the filename, use  to highlight a character, then press .
- To move the cursor in the filename, highlight the filename, then press .
- To save the report with the edited filename, press  **Save**, then press  **Save**.

To view the report, open it in LinkRunner Manager. Refer to the LinkRunner Manager help for instructions.

Set Up the Tester

To change settings on the tester, select **Tools** from the home screen.

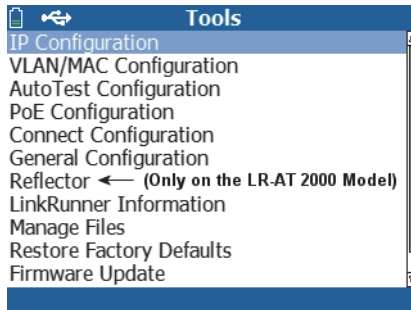
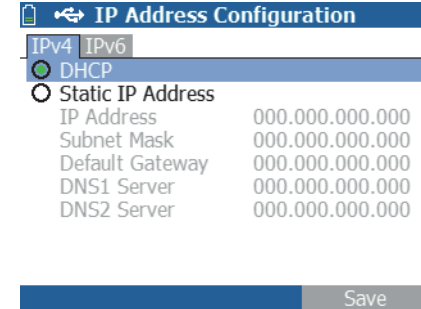

Figure 4. Tools Menu

ffy23.bmp

IP Configuration

Select **Tools > IP Configuration**.



ffy40.bmp

Figure 5. IP Configuration Screen

This screen allows you to enter an IPv4 address or use a DHCP address (default). It also allows you to enable IPv6 addressing (LR-AT 2000 only). LR-AT uses the IP address during AutoTest. During AutoTest, the LR-AT is required to connect to the network for Ping and TCP Connectivity testing.

At no other time, does the LR-AT connect to the network using IP addressing. This applies to the Switch and Cable test screens.

VLAN/MAC Configuration

Select **Tools > VLAN/MAC Configuration**.

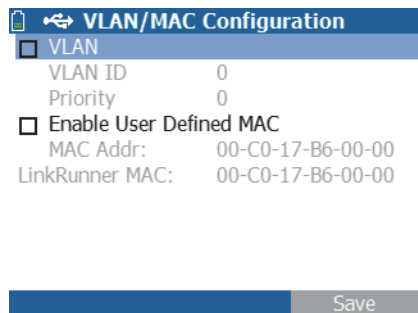

ffy41.bmp

Figure 6. VLAN/MAC Configuration Screen

This screen allows you to enable and enter the VLAN IP and its Priority level. By un-checking the VLAN check box, the VLAN capability is disabled.

This screen also allows you to enable and enter a user defined MAC address. By un-checking the Enable User Defined MAC check box, the LR-AT reverts back to the factory default MAC address.

AutoTest Configuration

Select **Tools > AutoTest Configuration**.

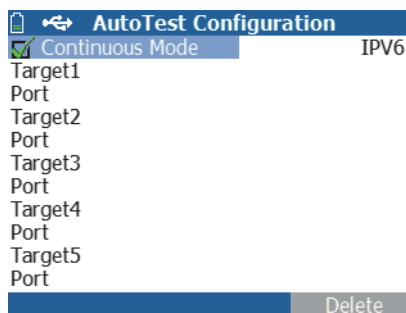

ffy42.bmp

Figure 7. AutoTest Configuration Screen

This screen allows you to enter up to ten key device addresses (Targets) to test connectivity. You may enter an IP address, URL, or DNS name. If no port is specified, AutoTest will perform an ICMP Ping test to that address. If a port is specified, AutoTest will perform a TCP Connectivity test (SYN/ACK).

The Continuous Mode check box allows the test to run continuously (checked) or one time (un-checked). When you exit the AutoTest screen, the test is stopped.

PoE Configuration

Select **Tools > PoE Configuration**.

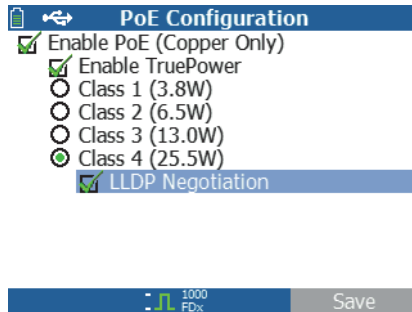

ff34.bmp

Figure 8. PoE Configuration Screen

By default, PoE is disabled. This screen allows you to enable/disable PoE detection, Enable TruePower™, and set the Class for detection. If you enable PoE and select Class 4 (25.5W), you can also enable LLDP Negotiation so that PoE is only reported if that criteria is met.

PoE TruePower™ is only available on the LR-AT 2000 model. TruePower™ puts a load on the PoE device and gives an accurate measurement on whether the device supports the Class selected.

Connect Configuration

Select **Tools > Connect Configuration**.

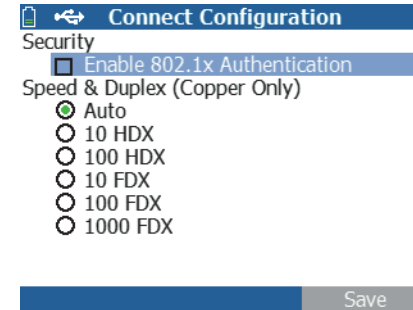

ff43.bmp

Figure 9. Connect Configuration Screen

This screen allows you to enable 802.1x Authentication and set the speed/Duplex.

For 802.1x Authentication, if a certificate is required, you must transfer it from your PC using the LinkRunner Manager PC application provided with LR-AT. Only one certificate can be installed on a LR-AT at a time.

For Speed & Duplex, Auto is the default and recommended configuration. 10 HDX is 10 Mbps half duplex, 1000 FDX is 1000 Mbps full duplex.

General Configuration

Select **Tools > General Configuration**.

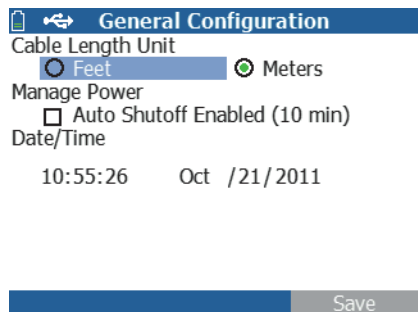

ffy44.bmp

Figure 10. General Configuration Screen

This screen allows you to set the units for the Cable test screen, Manage Power (10 minute automatic shutoff - default), and set the time/date.

Reflector Configuration (LR-AT 2000 Model)

This screen is used to configure the LR-AT 2000 for remote access to Fluke Networks EtherScope Network Assistant, MetroScope Service Provider, and OptiView Analyzer's throughput performance tests.

Note

The LR-AT 2000 can reflect jumbo frame sizes up to 9600 bytes.

Select **Tools > Reflector**. The default or pre-configured Reflector settings are displayed below

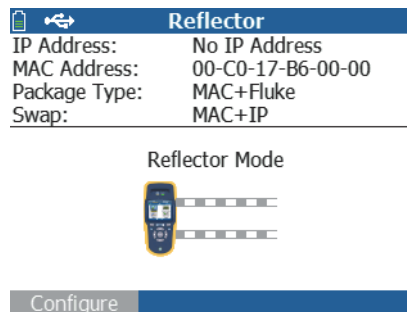

ffy32.bmp

Figure 11. Reflector Settings Screen

Select **Configure**.

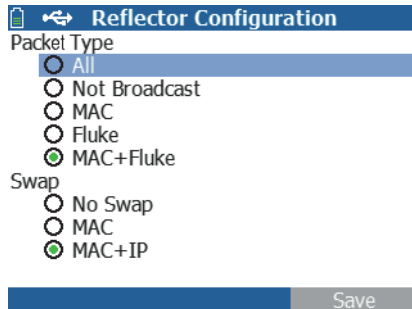

ffy33.bmp

Figure 12. Reflector Default Configuration Screen

The LR-AT 2000 must to be configured to:

MAC + Fluke - This filter setting allows the LR-AT 2000 to only reflect packets when the destination MAC address field matches the LR-AT 2000's own MAC address and Fluke payload.

MAC + IP - This swap setting allows the LR-AT 2000 to swap the source and destination MAC and IP addresses for packets that are reflected back to the analyzer.

Note

Any other Reflector setting may cause undesired traffic on your network.

LinkRunner Information

Select **Tools > LinkRunner Information**.

This screen displays the following LR-AT product information:

- **Serial Number:** The serial number is also shown under the battery pack.
- **MAC Address:** Media Access Control address. The unique address of the tester.
- **SW Version:** The version of software in the tester.
- **Build:** The build number of the software version.

Note

An SFP SX fiber adapter was connected to the tester in figure 13.

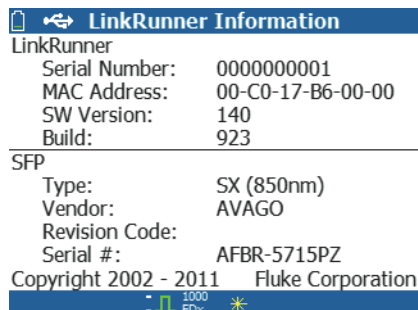

ffy45.bmp

Figure 13. LinkRunner Information Screen

Manage Files

Manage Files allows you to load a profile, save a profile, save a report, rename a profile or report, or delete a profile or a report.

You can save reports on the tester and transfer them to the LinkRunner Manager PC application. Reports transferred to LinkRunner Manager can be displayed and printed. Reports contain the AutoTest, Switch, and Cable test results.

Profiles contain the following tester information: IP, VLAN/ MAC, AutoTest, PoE, Connect, General, and Reflector configurations. These settings can be modified in LinkRunner Manager and on the tester.

To Load a Profile

- 1 Select **Tools > Manage files**.
- 2 Select **Load Profile**.
- 3 Select a Profile from the list.

To Save a Profile













- 1 Select **Tools > Manage files**.
- 2 Select **Save Profile**. The current setting are now saved to the profile filename shown at the bottom of the screen. To change the filename, select **F1 Edit**.
- 3 Select **F2 Save**.

To Save a Report



- 1 Select **Tools > Manage files**.
- 2 Select **Save Report**. The current measurement data is now saved to the report filename shown at the bottom of the screen. To change the filename, select **F1 Edit**.
- 3 Select **F2 Save** or .

To rename a file

- 1 Select **Tools > Manage files**.
- 2 Select **Rename file**.

- 3 Highlight either the **Report** or **Profile** folder.
- 4 Highlight the file, then press .
- 5 To edit the filename, press  **Edit**.
 - To delete characters in the filename, press  **Delete**.
 - To add characters to the filename, use     to highlight a character, then press .
 - To move the cursor in the filename, highlight the filename, then press  .
- 6 To rename the file with the name you made, press  **Save**, then press  **Rename**.

To delete a file

- 1 Select **Tools > Manage files**.
- 2 Select **Delete file**.
- 3 Highlight either the **Report** or **Profile** folder.
- 4 Highlight a file, then press .
- 5 Press  **Delete**.

Restore Factory Defaults

Restores any configuration changes to the following LinkRunner AT factory defaults.

- IP Configuration:
IPv4: DHCP
IPv6: Disabled
- VLAN/MAC Configuration:
VLAN: Disabled
VLAN ID: 0
Priority: 0
User Defined MAC: Disabled
MAC Address: Linkrunner MAC address
- AutoTest Configuration:
Continuous Mode: On
Target: none
- PoE Configuration:
Enable PoE: Disabled
Class: Class 1
- Connect Configuration:
802.1x: Disabled
Speed/Duplex: Auto

- General Configuration:
Cable Length Unit, Meters
Auto Shutoff, Enabled
- Set Language:
English

When you Select **Restore Factory Defaults**, you will be prompted with a two popup. Select  **OK**, then press .

The restore will be completed and the tester will turn off.

Firmware Update

- 1 Download the LinkRunner firmware update file from the Fluke Networks website, or contact Fluke Networks to get the update by other means. Save the file to your hard disk.
- 2 Get the latest version of LinkRunner Manager from the Fluke Networks website.
- 3 Start LinkRunner Manager on your PC.
- 4 Turn on the tester.
- 5 Select **Tools > Firmware Update > select**  **Update**.

- 6 Use the USB cable supplied with the tester to connect the tester to the PC.
- 7 In LinkRunner Manager, select **LinkRunner > Update Software**.
- 8 Click **Select**, find and select the update file (.zip extension), then click **Select**.
- 9 Click **Update**.
- 10 When the transfer is completed, disconnect the USB cable from the tester.
- 11 The screen on the tester goes blank while it installs the update file. When the update is completed, restart the tester.

Caution

Do not disconnect the LinkRunner from the PC or remove the battery during the update.

Transfer Saved Profiles to/from LinkRunner Manager

Use LinkRunner Manager to view and configure the profiles that are saved on the tester. To transfer profiles from the tester to LinkRunner Manager:

- 1 Install the latest version of LinkRunner Manager software on your PC. Start the software.
- 2 Turn on the tester.
- 3 Use the USB cable supplied with the tester to connect the tester to the PC.
- 4 To see the profiles that are on the tester, select **Tools > Profile Manager** from the LinkRunner Manager tool bar. Profile names display under the LinkRunner Profile Files pane.
- 5 Highlight a profile in this pane and select **Transfer from LinkRunner**.
- 6 When you are done editing the profile, highlight it and select **Transfer to LinkRunner**.

Set Language

To change the language displayed in all screens

- 1 Select **Tools > Set Language**.
- 2 Highlight a language and press  **Save**.

Using AutoTest, Switch, and Cable Test

Using AutoTest

AutoTest can test up to ten targets. These targets can be local or off-net targets (devices). You can enter the IP address or a DNS name. If you specify a target address without specifying a port number, AutoTest will perform an ICMP Ping to the target address. If you specify a port number, AutoTest will perform a TCP Connectivity test (SYN/ACK). See figures 14 and 15.

Select **Tools > AutoTest Configuration** and enter the target address(s). Entering a port number is optional.

AutoTest will attempt to Ping/Connect to the target device three times. If **Continuous** is selected, the test will run until you exit the AutoTest screen.

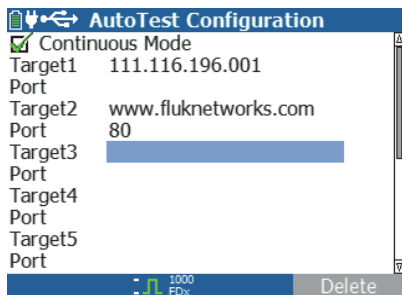

ffy28.bmp

Figure 14. AutoTest Configuration Screen

Select **AutoTest** on the Home screen. AutoTest will run and the test results should look similar to figure 15.



ffy27.bmp

Figure 15. AutoTest Results Screen

The nearest switch is discovered and its name, port, VLAN ID, model, and IP address are displayed. Then the DHCP server information is displayed. Finally, the Gateway and DNS server(s) are displayed along with the target device(s).

Expand on each device to display the test results as shown below.

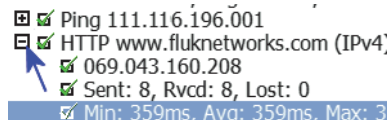

ffy31.bmp

Figure 16. Expanding Test Results

Using the Nearest Switch Test

The Switch test screen displays the nearest switch. The nearest switch is discovered by locating the “port advertisement” on the first few packets seen by LR-AT.

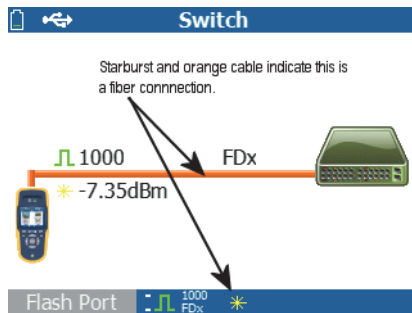

Figure 17. Nearest Switch Results

ffy46a.bmp

Select **Flash Port** to stimulate the switch to flash the LED on the port that the LR-AT is connected into. This can help locate the switch port in the closet. Set the Flash Port flash rate from slow to fast to differentiate from the other switch port LED flash rates.

Using the Cable Test

There are three use models for using the Cable screen:

- Connect a cable from the top LR-AT RJ-45 connector into the side cable test RJ-45 connector to measure length and wire mapping.
- Connect an open cable (non-terminated) into the top LR-AT RJ-45 connector and measure length. An un-terminated cable can also be traced using a Fluke Networks IntelliTone tester and the **Tone** function.
- Connect a cable into the top LR-AT RJ-45 connector and select **Tone**. Using a Fluke Networks IntelliTone tester, you can trace the wire or locate it in the switch closet.

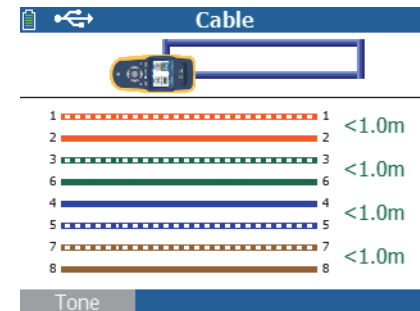

Figure 18. Cable Test Results

ffy30.bmp

Using PoE Feature

PoE is disabled by default. To enable PoE, select **Tools > PoE Configuration**, and check **Enable PoE**. Select the Class you want to verify. If you have purchased the LR-AT 2000, you can TruePower™ test the Class. The results are displayed in the Autotest and Switch tests.

When you select a PoE Class higher than the switch can handle, LR-AT 2000 will provide the loaded results indicating the switch can not handle this Class setting. The LR-AT 1000 will display the unloaded results indicating voltage and wattage selected.

The following example was tested on a Class 3 (13w) switch. The tester PoE configuration was set to Class 4 (25w) with TruePower™ disabled.

Figure 19 displays the AutoTest results and Figure 20 displays the Switch results. Notice in the Autotest results, the wire pair polarity, wattage requested and wattage received, voltage and PSE type are given.

PSE is the Power Sourcing Equipment rating, Type 1 (12.95W - 15.40W) and Type 2 (25.5W - 34.20W).

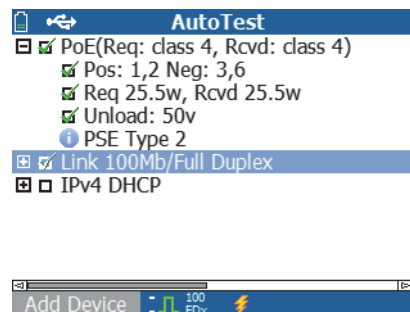

ffy37.bmp

Figure 19. TruePower™ Disabled PoE AutoTest Results

In the next example, the Switch results are shown with the same setup, i.e., no load, Class 4 (25.5w).

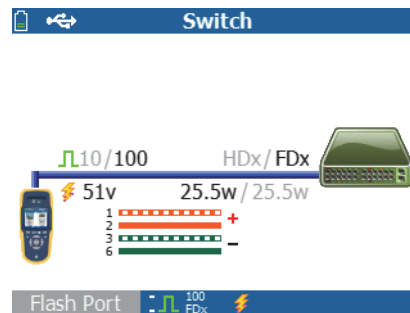

ffy39.bmp

Figure 20. TruePower™ Disabled PoE Switch Results

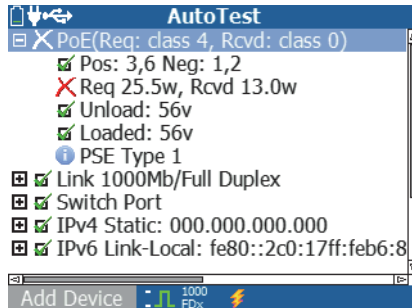

ffy47.bmp

Figure 21. TruePower™ Enabled PoE AutoTest Results

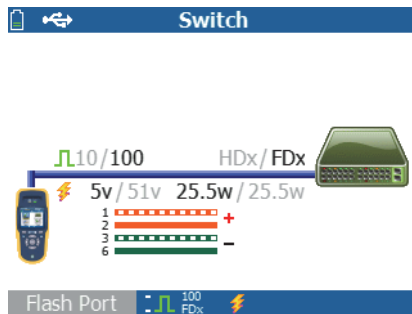

ffy38.bmp

Figure 22. TruePower™ Enabled Poe Switch Results

Notice the switch was loaded down to 5v indicating it does not support the selected Class.

Using the Reflector Feature (LR-AT 2000 only)

The Reflector feature allows the LR-AT 2000 to be used as a remote device for Fluke Networks EtherScope Network Assistant, MetroScope Service Provider, and the OptiView Analyzer's throughput performance tests.

See Reflector Configuration on page 14 for setting up this feature. Once set up, the device can be used as the remote responding device for throughput performance testing. There is no start or stop, and no results are displayed on the tester.

Using the Fiber Connection

Simply plug in the desired SFP adapter into the fiber port on the top of the tester and connect the fiber cable to the network. If both fiber and RJ-45 copper are connected to the network, the copper connection has priority.

Figure 23 shows the Switch results through a fiber connection with link, 1000 Mbps speed, full duplex, with a signal strength of 7.35dBm.

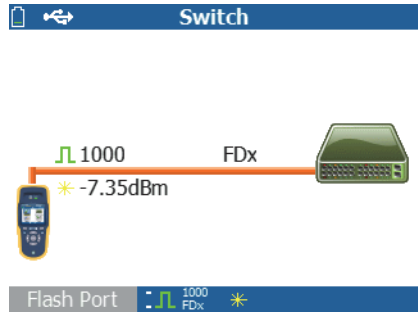

ffy46.bmp

Figure 23. Fiber Connected Switch Results

- If you replace parts that are not specified as replacement parts, the warranty will not apply to the product and you can make the product dangerous to use.
- Use only service centers that are approved by Fluke Networks.

Maintenance

Warning

To prevent possible fire, electrical shock, personal injury, or damage to the tester:

- Do not open the case. You cannot repair or replace parts in the case.
- Use only replacement parts that are approved by Fluke Networks.

Options and Accessories

Table 2 shows options and accessories available for the LinkRunner AT Tester. For a complete list of options and accessories visit the Fluke Networks website at www.flukenetworks.com.

Table 2. Options and Accessories

Option or Accessory	Fluke Networks Model Number
Lithium ion battery pack for the LinkRunner tester	WBP-LION
Adapter/charger for connection to an automobile cigarette lighter	MS-Auto-Chg
AC adapter/charger, universal, 120-240 Vac	DTX-ACUN

Specifications

Environmental Specifications

Table 3. Environmental Specifications

Operating temperature

32°F to 113°F (0°C to +45°C)

Note

The battery will not charge if the internal temperature of the tester is above 113°F (45°C).

**Operating relative humidity
(% RH without condensation)**

90% (50°F to 95°F; 10°C to 35°C)
75% (95°F to 113°F; 35°C to 45°C)

Storage temperature

-4°F to 140°F (-20°C to +60°C)

Shock and vibration

Random, 2 g, 5 Hz-500 Hz (Class 2) 1 m drop

Safety

EN 61010-1 2nd edition
EN/IEC 60825-1:2007, EN/IEC 60825-2:2004+ A1:2007 (LRAT-2000 only)

Altitude

4,000 m; Storage: 12,000 m

EMC

FCC Part 15 Class A, EN 61326-1

Certifications and compliance

 Conforms to relevant European Union directives

 Conforms to relevant Australian standards

 Listed by the Canadian Standards Association

General Specifications

Table 4. General Specifications

Media Access	10BASE-T, 100BASE-TX, 1000BASE-T (IEEE-802.3) and Poe (IEEE 802.3at)
Cable Test	Pair lengths, opens, shorts, splits, crossed, straight through, and cable ID
Tone Generator	IntelliTone digital tone: [500 KHz]; analog tones: [400Hz, 1KHz]
Ports	RJ45 copper port 1000BASE-X fiber adapter port (2000 only)
Dimensions	3.5 in x 7.8 in x 1.9 in (8.9 cm x 19.8 cm x 4.8 cm)
Weight	18 oz (0.5 kg)
Battery	Removable, rechargeable lithium-ion battery pack (18.5 Watt-hrs)
Battery life	Typical operating life is 6 hours. Typical charge time is 3 hours.
External AC adapter/charger	AC input 90-264 Vac 48-62 Hz input power DC output 15 Vdc at 1.2 amps
Display	2.8 in color LCD (320 x 240 pixels)
Keypad	12-key elastomeric
LEDs	2 LEDs (transmit and link Indicators)
Host interface	USB 5-pin mini-B

LinkRunner Manager Software

Table 5. LinkRunner Manager Software

Supporting operating system	Windows Vista, Windows XP, Windows 7
Processor	400 MHz Pentium processor or equivalent (minimum); 1 GHz Pentium processor or equivalent (recommended)
RAM	96 MB (minimum); 256 MB (recommended)
Hard disk	Up to 500 MB of available space may be required
Display	1024 x 768 high color, 32-bit (recommended)
Hardware	USB Port