

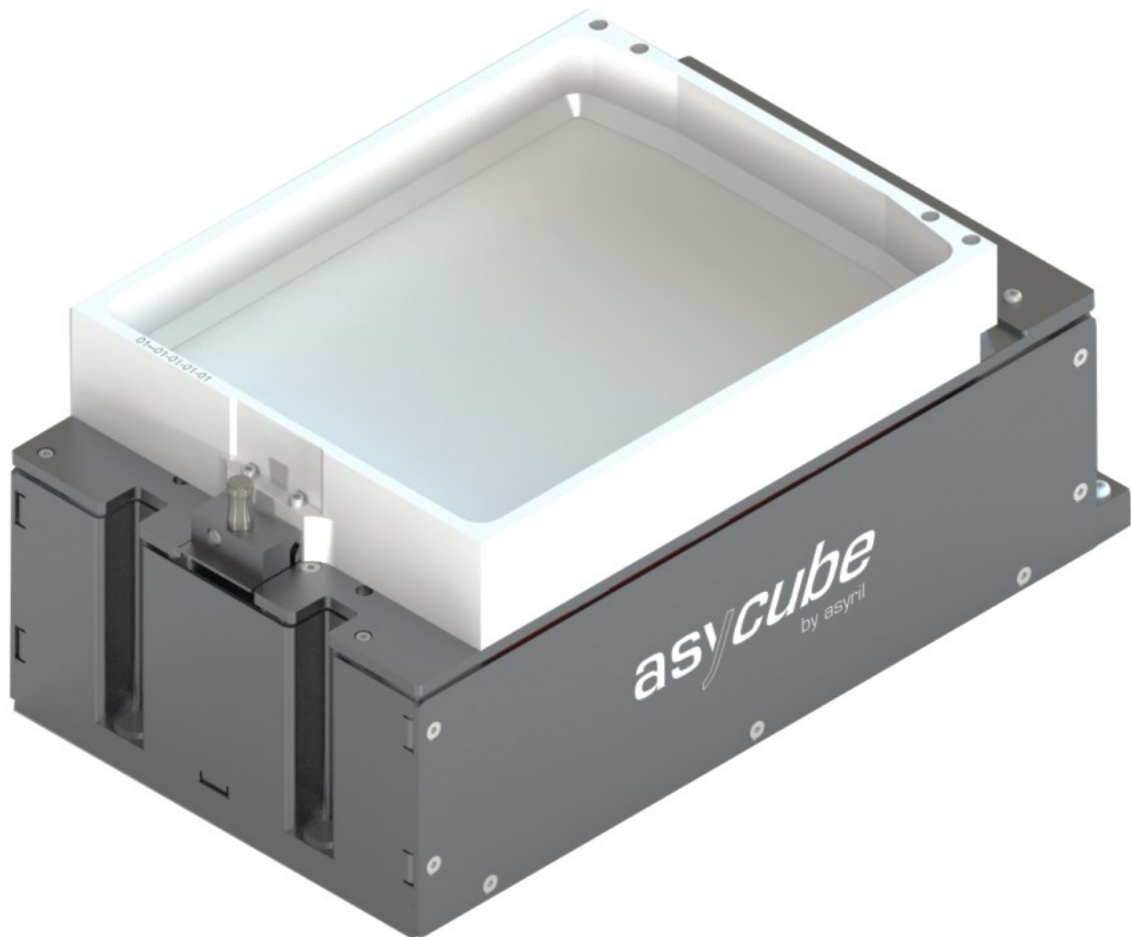

# ***Asycube Largo A5***

## ***Operating Manual***



<b>Document</b>	Asyril_ACUBE-LA5-01_Operating_Manual_E		
<b>Version</b>	v1.21	<b>Date</b>	16.06.2015
<b>Articles</b>	ACUBE-LA5-01		

	Asycube Largo A5 - AsyriL SA Operating Manual	© Copyright AsyriL S.A.
Introduction	v1.21	FO 32.03.118

## Table of Contents

<b>1.</b>	<b>INTRODUCTION.....</b>	<b>4</b>
1.1.	GENERALITIES .....	4
1.2.	SAFETY PRECAUTIONS .....	5
1.2.1.	<i>General safety precaution</i> .....	5
1.2.2.	<i>Danger</i> .....	6
1.3.	WARRANTY INFORMATION .....	7
1.4.	CE INFORMATION .....	7
1.5.	RELATED MANUALS .....	8
<b>2.</b>	<b>DESCRIPTION .....</b>	<b>9</b>
2.1.	FIRST GLIMPSE AT THE PRODUCT.....	9
2.2.	GENERAL CHARACTERISTICS.....	10
2.2.1.	<i>Technical features</i> .....	10
2.2.2.	<i>Overall dimensions</i> .....	11
2.2.3.	<i>Visual signals</i> .....	13
2.3.	PERFORMANCE.....	14
2.3.1.	<i>Picking surface</i> .....	14
2.3.2.	<i>Displacement of the parts</i> .....	14
2.4.	ELECTRICAL INTERFACES.....	16
2.4.1.	<i>Overview</i> .....	16
2.4.2.	<i>Power connection</i> .....	17
2.4.3.	<i>Communication</i> .....	18
2.4.4.	<i>Backlight Synchronization</i> .....	18
2.4.5.	<i>Digital input 1 and 2</i> .....	19
2.4.6.	<i>Digital output for hoppers 1 and 2</i> .....	19
2.5.	MECHANICAL INTERFACES .....	20
2.5.1.	<i>Attachment of the Asycube</i> .....	20
2.6.	ACCESSORIES AND OPTIONAL MODULES.....	21
2.6.1.	<i>Additional platform</i> .....	21
2.6.2.	<i>Backlight</i> .....	22
2.6.3.	<i>Cables</i> .....	23
<b>3.</b>	<b>TRANSPORTATION, HANDLING AND INSTALLATION .....</b>	<b>24</b>
3.1.	PACKAGING OF THE PRODUCT, TRANSPORTATION AND HANDLING .....	24
3.2.	BEFORE UNPACKING.....	24
3.3.	UNPACKING INSTRUCTIONS.....	25
3.4.	INSTALLATION AND STORAGE ENVIRONMENT .....	26
3.4.1.	<i>Installation environment</i> .....	26
3.4.2.	<i>Storage environment</i> .....	26

	Asycube Largo A5 - Asyri SA Operating Manual	© Copyright Asyri S.A.
Introduction	v1.21	FO 32.03.118

<b>4.</b>	<b>MAINTENANCE AND REPARATION</b>	<b>27</b>
4.1.	SAFETY PRECAUTIONS	27
4.1.1.	<i>General safety precautions</i>	27
4.1.2.	<i>Specific warnings</i>	27
4.2.	PERSONNEL RESPONSIBLE FOR MAINTENANCE OR REPARATION	27
4.3.	MAINTENANCE	28
4.3.1.	<i>Periodic maintenance schedule</i>	28
4.3.2.	<i>Remove the platform module</i>	29
4.3.3.	<i>Control and Cleaning of the platform</i>	29
4.4.	REPARATION	30
4.4.1.	<i>Exchanging / installing the backlight</i>	31
4.4.2.	<i>Recover IP address using default IP address</i>	36
4.5.	TECHNICAL SUPPORT	38
4.5.1.	<i>For better service</i>	38
4.5.2.	<i>Contact</i>	38
<b>5.</b>	<b>ANNEXES</b>	<b>39</b>
5.1.	CONDITION OF USE OF BACKLIGHT	39
5.2.	CE CERTIFICATE	43

	Asycube Largo A5 - Asyрил SA Operating Manual	© Copyright Asyрил S.A.
Introduction	v1.21	FO 32.03.118

# 1. Introduction

## 1.1. Generalities

The following document is the property of Asyрил S.A. and may not be copied or circulated without permission. The information contained in this document is subject to change without notice for the purpose of product improvement. Before operating your product, please read this document in order to ensure a correct use of the product. Nevertheless, if you meet difficulties during the operation or the maintenance, please, feel free to contact Asyрил customer service.

In this manual, the safety precautions that you must respect are classified as: “Danger”, “Warning” and “Note”; the following symbols are used:



### **DANGER!**

Failure to observe the instruction may result in serious injury.



### **DANGER!**

Failure to observe the instruction may result in electrocution or serious injury due to electric shock



### **WARNING!**

Failure to observe the instruction may result in injury or property damage.



### **NOTE :**

*The user should read carefully this information to ensure the correct use of the product, although failure to do so would not result in injury.*



### **REFER TO ...**

*For more information on a specific subject, the reader should read other manual, or refer to other paragraph.*



### **WARNING!**

Asyрил shall not be liable whatsoever for any loss or damage arising from a failure to observe the items specified in “Safety Precautions.” The customer is responsible to provide the necessary instruction to the persons concerned.



### **NOTE :**

*All dimensions in this document are expressed in millimeters*

	Asycube Largo A5 - Asyrl SA Operating Manual	© Copyright Asyrl S.A.
Introduction	v1.21	FO 32.03.118

## 1.2. Safety precautions

### 1.2.1. General safety precaution

#### 1.2.1.1. Transport



**DANGER!**

Be aware of the weight and take care when transporting the system. For more information, please refer to chapter 3 “Transportation, handling and installation”

#### 1.2.1.2. General



**DANGER!**

Be sure that all power sources and other cables to the unit are disconnected before working on the product.



**DANGER!**

Only qualified personnel (trained by Asyrl and with professional experience) are authorized to work on this device.



**DANGER!**

Do not unscrew the housing of the system controls. Serious injury or death could result from electric shock. Only authorized personnel from Asyrl SA are allowed to access this part of the system for maintenance or for repair.



**DANGER!**

Do not plug or unplug cables of the system unless it is switched off.



**DANGER!**

Never modify the product. Unauthorized modification may cause the product to malfunction, resulting in injury, electric shock, fire, etc.



**DANGER!**

Turn off the power to the product in the event of power failure. Failure to do so may cause the product to suddenly start moving when the power is restored.



**DANGER!**

Do not use the product in a place where it may come in contact with water or oil droplets.

#### 1.2.1.3. Disposal

When the product becomes no longer usable or necessary, dispose of it properly as an industrial waste.



**WARNING!**

Observe the valid legal regulation for appropriate disposal protecting environment.

<b>asyril</b> experts in mechatronics	Asycube Largo A5 - Asyrl SA Operating Manual	© Copyright Asyrl S.A.
Introduction	v1.21	FO 32.03.118

## 1.2.2. Danger

### 1.2.2.1. Safety Equipment for Operators

- For safety reasons operators must wear protective eyewear when using the backlight



#### NOTE :

*It is the customer responsibility to install warning signs informing that anyone working around the Asycube must wear safety equipment.*

### 1.2.2.2. Specific danger



#### Backlight

The Asycube has an integrated Backlight that persists of LED's (Light Emitting Diodes). These LED's emit visible or non-visible radiation depending on the color of the Backlight. LED's illumination can create discomfort, cornea, retinal and lens damage.

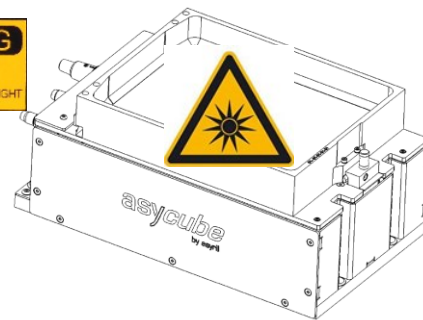

**Figure 1-1 : Specific warnings**

The used LED are class 0 according to the norm EN 62471. It is the responsibility of customers to document their own application and instruct employees on procedures to limit exposure to LED radiation. Following prevention agent can be suggested:

- Interpose, insofar as the job allows, a high pass filter at  $x$  nm depending on the color (see table below) under a fixed or adjustable connection between the source and the employee
- When the implementation of the foregoing is not possible, provide workers with goggles or face shield suitable for blocking radiation beyond 700nm;
- Prohibit or limit as possible direct access to the source (exposure in the axis of radiation), see "Conditions of use of products TPL VISION" below
- Establish a security perimeter to prevent operators from approaching the source at distances beyond the nominal ocular hazard recommended by the manufacturer
- In all cases, ensure that the means used properly mitigate exposure variables (characteristics of screens or goggles to choose based on wavelength which operators are exposed).



*Refer to "5.1 Condition of use of backlight" on page 39 for the complete calculation sheet on minimal distance to respect for each kind of backlight.*



**Temperature**

The active elements into the asycube make the surfaces shown on the picture heating up to 45°C in nominal use. This temperature can nevertheless increase to 55°C in extreme use.

It is the responsibility of customers to document their own application and instruct employees on procedures to avoid contact with these surfaces

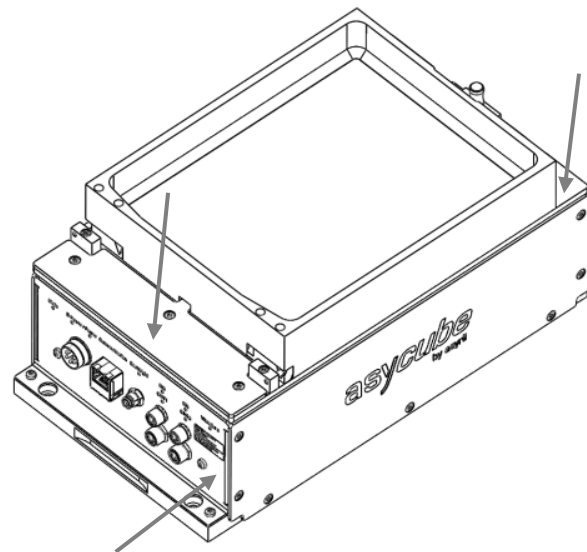

**Figure 1-2 :Specific warnings**

**1.3. Warranty information**

You will find all the Asyrl warranty information (duration, scope of warranty ...) on the general conditions of sale.

**1.4. CE information**

The declaration of incorporation as a partly completed machinery can be found here below.

**NOTE:**



The partly completed machinery (Asycube) must not be put into service until the final machinery into which it is to be incorporated has been declared in conformity with provisions of this directive, where appropriate.



*Refer to "5.2 CE Certificate" on page 43 for the complete CE Certificate of the asycube Largo.*

<b>asyril</b> experts in mechatronics	Asycube Largo A5 - Asyri SA Operating Manual	© Copyright Asyri S.A.
Introduction	v1.21	FO 32.03.118

## 1.5. Related manuals

As described in the Table 1-1, this manual is an integral part of the Asycube documentation set. This manual covers the installation, a technical description, the maintenance, and the reparation of your system. Information on the transport and safety precautions are also included in this manual.

Manual Title	Manual reference	Description of the content
<b>Asycube Unpacking Instructions</b>	ACUBE-LA5-01_Unpacking_Instructions	Describes how to unpack your asycube.
<b>Asycube Operating manual</b>	ACUBE-LA5-01_Operating_Manual	THIS MANUAL
<b>Asycube HMI manual</b>	ACUBE-MEZ-FOR-LA5_User_Interface_Manual	Describes how to use the HMI (simply move the parts, and configure the Asycube's vibrations ...)
<b>Asycube Programming guide</b>	ACUBE-LA5-01_Programming_Guide	Describes the way of programming and integrating your Asycube in the final machine.
<b>Asycube DLL</b>	ACUBE-DLL_Integration_Guide	Describes the Asycube dll's that are High-level libraries which helps to integrate Asycubes using .Net 3.5 environment.

**Table 1-1 : related manuals**



## 2. Description

### 2.1. First glimpse at the product

Asycube sets new standards in small part feeding. Its 3D vibratory platform allows fast and flexible presentation of small parts (1 mm to 40 mm) to a robot equipped with a vision system.

The core of Asycube is a platform that can vibrate in three orthogonal directions. By selecting appropriate vibration signals, a high flexibility in displacing parts on the platform is reached (forward, backward, sidewise) and flipping is made possible.

It consists in :

- (A) A 3D vibrating platform (called "plate")
- (B) Electrical interfaces (communication, power supply, I/Os...)



*For more information on electrical interfaces to the Asycube, please refer to "2.4. Electrical Interfaces" on page 16*

- (C) An integrated mechanism allowing to remove the platform easily without additional tooling
- (D) An integrated backlight (D) (optional) that allows an easy recognition of the parts from a camera placed above

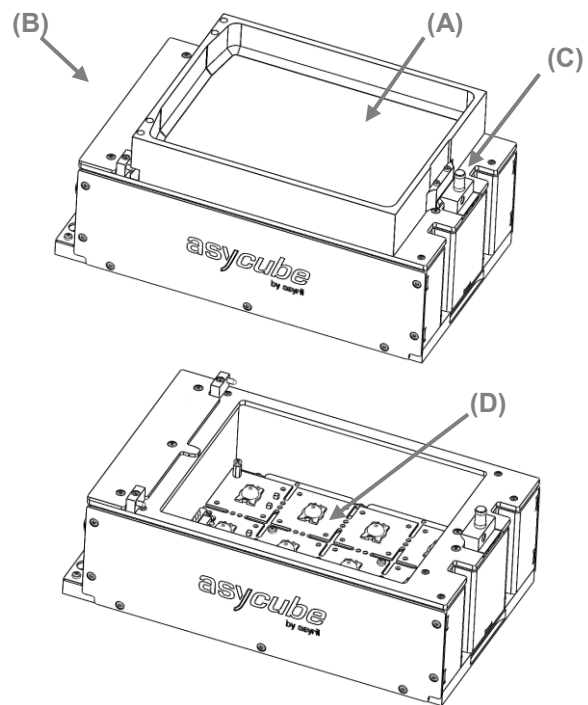

**Figure 2-1 : Asycube overview**



*For more information on how to remove or change the platform, please refer to "4.3.2. Remove the platform module" on page 29*



*For more information on the procedure to control the platform vibrations, please refer to the HMI manual*



*For more information on the backlight color and the procedure to exchange the backlight, please refer to "4.4.1 Exchanging / installing the backlight" on page 31*

<b>asyril</b> experts in mechatronics	Asycube Largo A5 - Asyri SA Operating Manual	© Copyright Asyri S.A.
Description	v1.21	FO 32.03.118



## 2.2. General Characteristics



### WARNING !

Do not use the product outside the specifications. In cases of non-respectation, the product guarantee will expire.

### 2.2.1. Technical features

<b>Asycube largo A5</b>	
<b>Typical part size</b>	from 2 mm to 40 mm side length
<b>Integrated high power LED backlight</b>	Optional 
<b>Interchangeable backlight color</b>	<i>(green, red, blue, white, Infrared) please refer to "2.6.2 Backlight" on page 22 for more information.</i>
<b>Independent vibrations in three orthogonal directions</b>	
<b>Interchangeable vibration surface</b>	<i>please refer to section "2.6.1 Additional platform" on page 21 for more information.</i>
<b>Vibration frequency configurable</b>	up to 100 Hz
<b>Maximal weight on the platform</b>	0.4 kg
<b>Digital Output for hoppers</b>	2
<b>Digital Input</b>	2
<b>Analog Output</b>	2

**2.2.2. Overall dimensions**

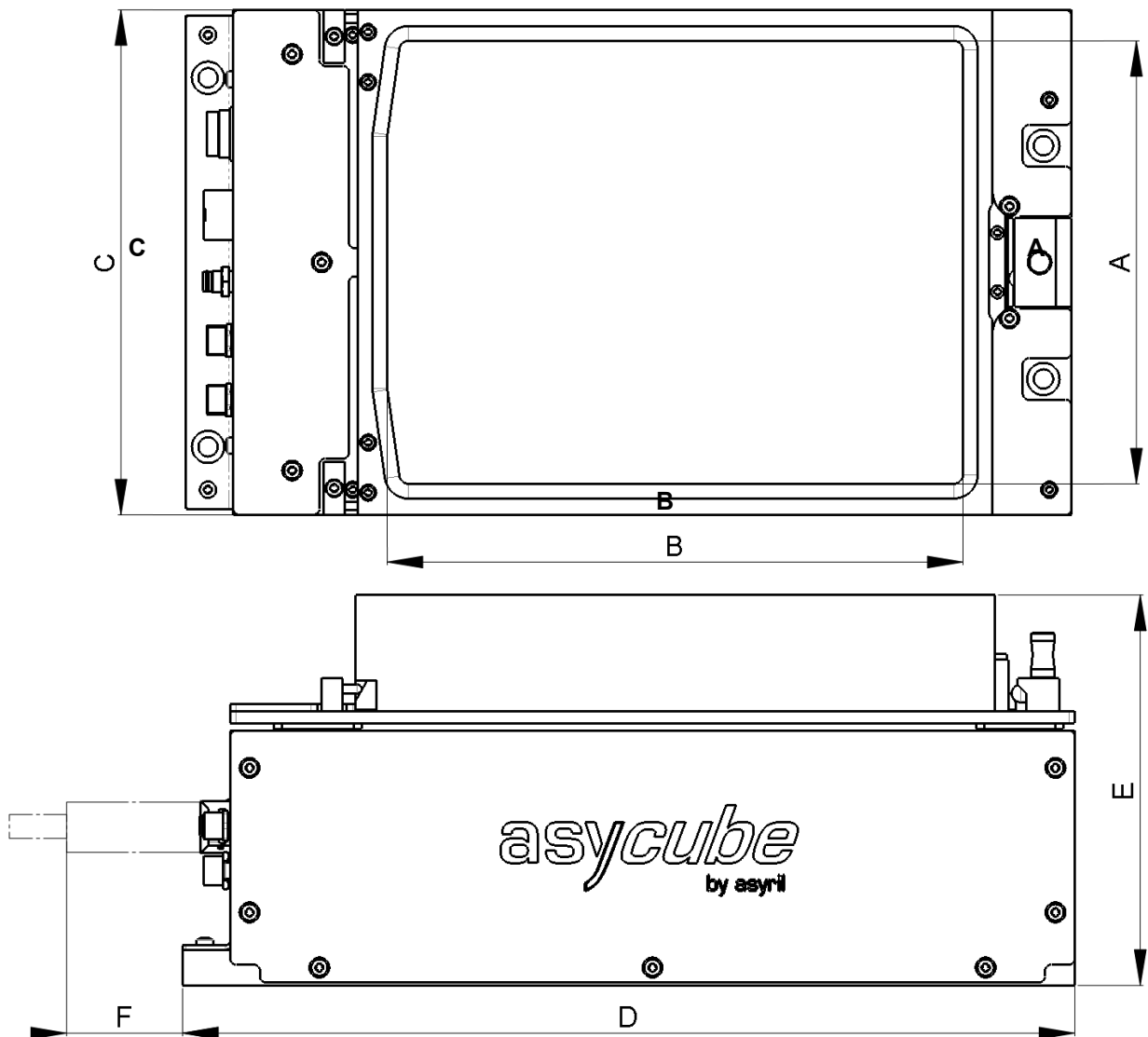

**Figure 2-2 : overall dimensions largo A5**

Characteristic	Asycube Largo A5	
Footprint	C	171 mm
	D	300 mm
	F	45 mm
Size of vibration platform	A	150 mm
	B	195 mm
	E	132 mm
Weight with platform and backlight	7.8 kg	

	Asycube Largo A5 - Asyri SA Operating Manual	© Copyright Asyri S.A.
Description	v1.21	FO 32.03.118

Additional space is needed around the Asycube to be able to remove the platform module with the integrated tool :

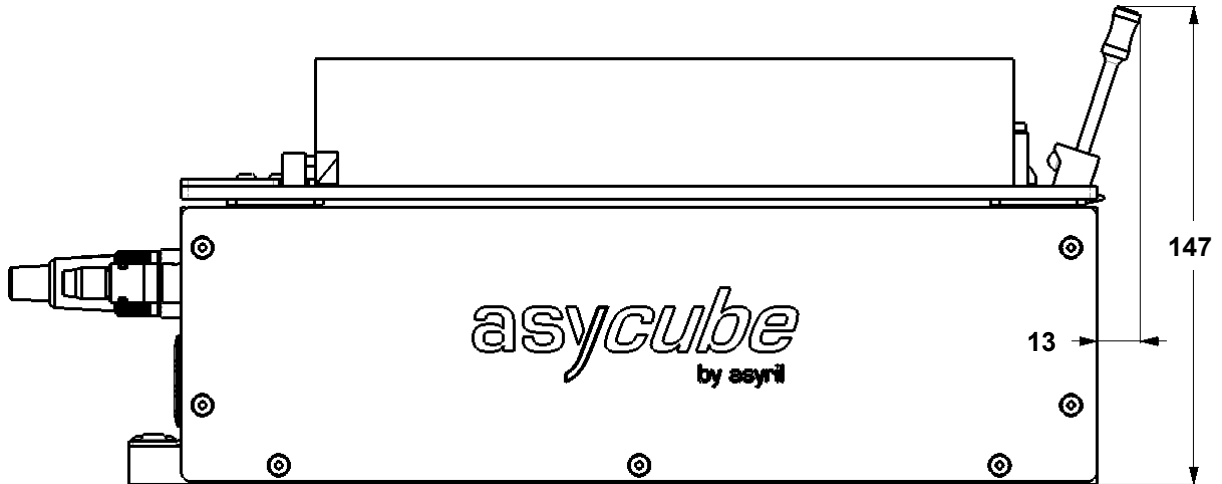

Figure 2-3 : overall dimensions with "lever"



Refer to [“4.3.2 Remove the platform module”](#) on page 29 for more information on how to remove the platform :

### 2.2.3. Visual signals

The led give important information on the state of the Asycube :

Led	State	Meaning
1	Blinking "ton" 100ms	System in standby
	Blinking "ton" 900ms	System in service
2	On	24V on S-Power input
3	On	24V on Power input
4	Blinking	Communication (Send/Receive TCP packet)
5	On	24V on backlight synchronization input
6	On	24V on input 1
7	On	24V on input 2
8	On	Platform vibrating
9	On	24V on output 1
10	On	24V on output 2

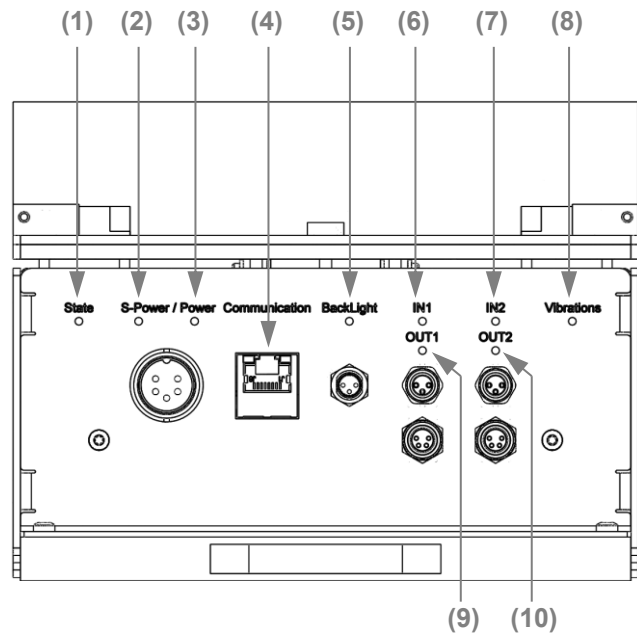

Figure 2-4 : Asycube Operating Indicator LED's

## 2.3. Performance

### 2.3.1. Picking surface

The maximum picking surface dimensions corresponds to the Asycube platform size :

A	195
B	150

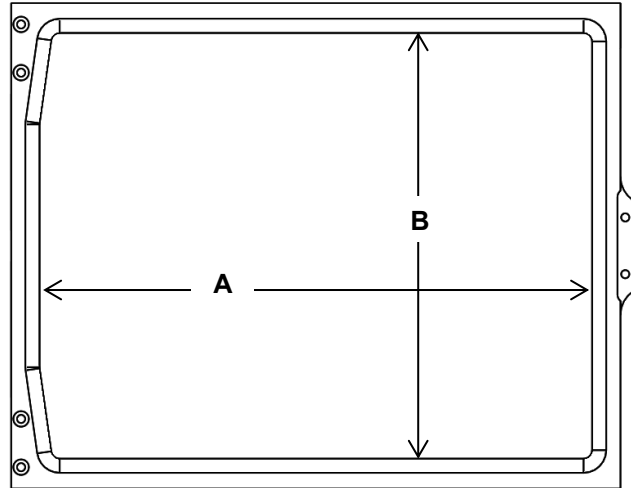

Figure 2-5 : Picking surface

### 2.3.2. Displacement of the parts

#### 2.3.2.1. Standard movement

To define a specific movement with the Asycube several parameters need to be configured. For each movement on the cube, twelve parameters must be set. Calling these twelve parameters will generate specific vibrations (corresponding to the sum of the movements of the four actuators in each corner of the platform).

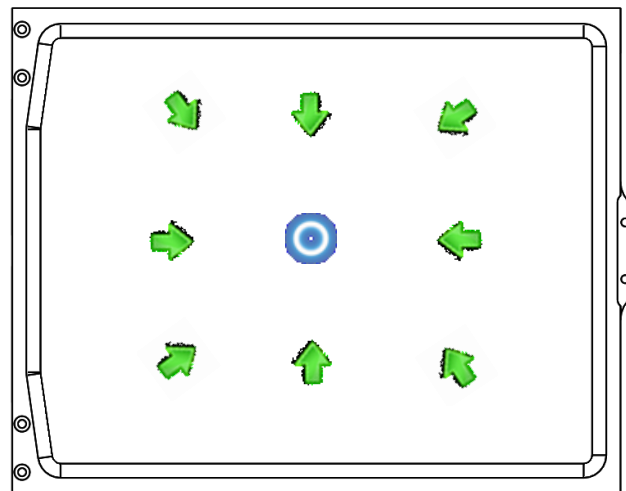

Figure 2-6 : predefined displacement of the parts

The figure on the right shows the predefined standard movements.

### 2.3.2.2. *Advanced movement*

On the Asycube Largo A5, advanced movements can be achieved. Indeed, it is possible to center the components along the long side or the short side of the plate, as represented on the figure on the right.

With a sequence of three movements you can spread easily the parts on the surface :

1. Center (long side)
2. Center (short side)
3. Flip

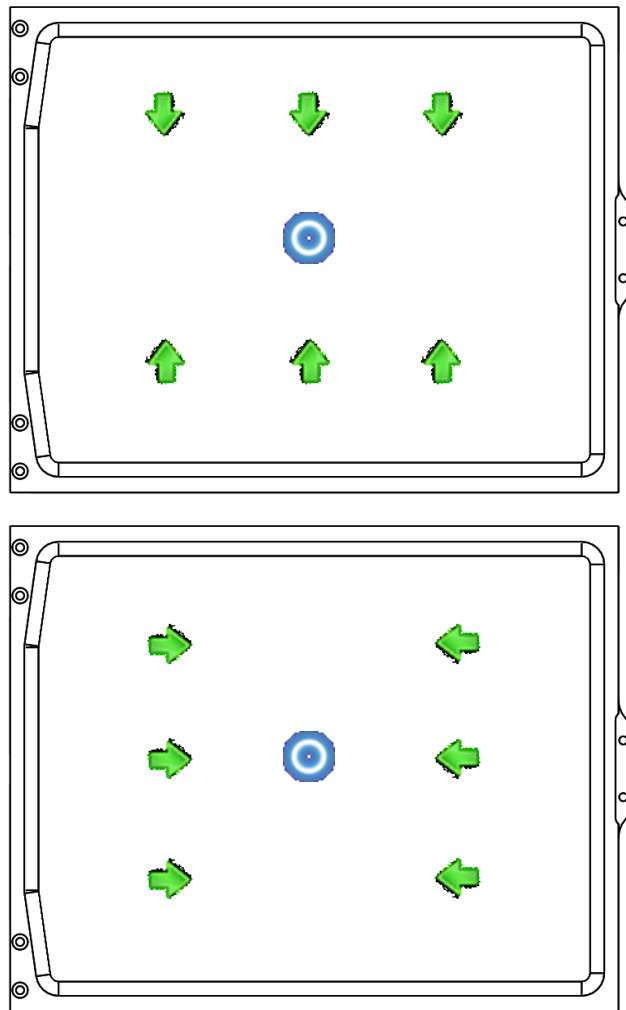

**Figure 2-7 : predefined displacement of the parts**



*For more information on these parameters, and to learn how to configure them, in order to control the cube vibrations, please refer to the User manual*

## 2.4. Electrical Interfaces

### 2.4.1. Overview

Asycube is a standalone module with its own controller. The electrical interfaces to the Asycube are situated at the back of the product:

- (A) Power connection
- (B) Ethernet connection (RJ45)
- (C) Backlight synchronization
- (D) Digital Input 1
- (E) Digital Input 2
- (F) Digital and analog Output 1 for hopper
- (G) Digital and analog Output 2 for hopper

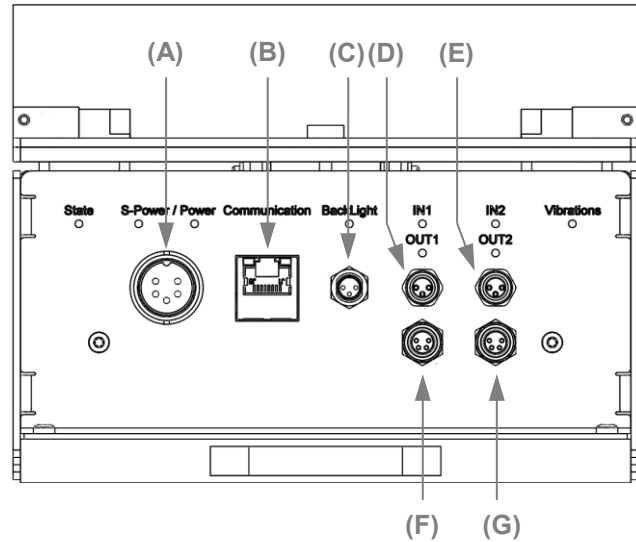

**Figure 2-8 : Electrical interfaces to the Asycube**



**NOTE :**

The cables are not part of the feeder, but can be ordered separately. (Please, refer to chapter 2.6.3 "Cables")



## 2.4.2. Power connection

### WARNING !



- Before supplying power to the Asycube, check that your distribution voltage is the same as the nominal voltage.
- Never disconnect the power cables. Always turn the machine off and then cut the power
- Use PELV (protected extra-low voltage) nominal voltage

Pin	Signal description
(1)	24VDC PELV S-Power
(2)	0V GND S-Power
(3)	24VDC PELV Power
(4)	0V GND Power
(5)	EARTH

Connector type (on asycube side) :  
M16, 5 Poles, male

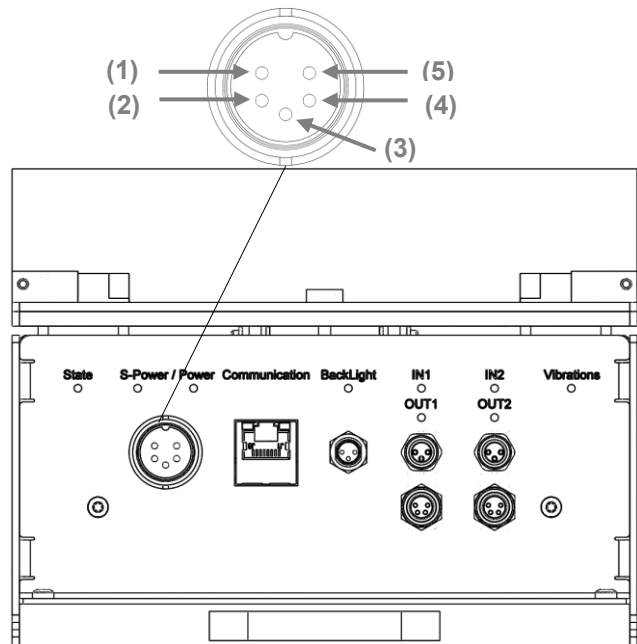

Figure 2-9 : power connection

In case of all functions working simultaneously (vibration, backlight, outputs), the current increases to 8A.

Characteristic	Value
Voltage	+24V DC $\pm$ 5%
Current Power	5A
Current S-Power	3A

### WARNING !



- S-Power is the safety power. This 24V is the power supply of backlight and digital outputs. Cutting this 24V permits to be sure that the backlight and the outputs stay OFF (e.g. to secure IR backlight danger). As a consequence, you must get a 24V signal on the S-Power to be able to use the backlight.

### 2.4.3. Communication

The communication with the asycube is established by a standard Ethernet communication via RJ45 port **(A)**

Characteristic	Value
<b>Default IP address</b>	192.168.127.254
<b>Default subnet mask</b>	255.255.255.0
<b>Port</b>	4001
<b>MAC address</b>	Can be read by ARP request



For more information on the procedure to restore the default IP address, please see chapter 4.4.2.

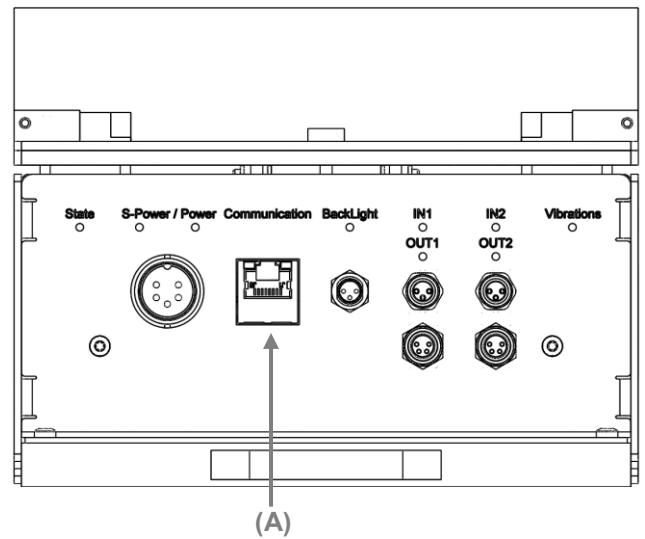

Figure 2-10 : Ethernet connection RJ45

### 2.4.4. Backlight Synchronization

A standard M8 three-pins female cable enables to synchronize camera acquisition and Asycube backlight illumination, it must be connected as follows :

Pin	Signal
(1)	Not wired
(3)	0V GND
(4)	+24 V pulse (illumination synch.)

Connector type (on asycube side) :  
M8, 3P, male

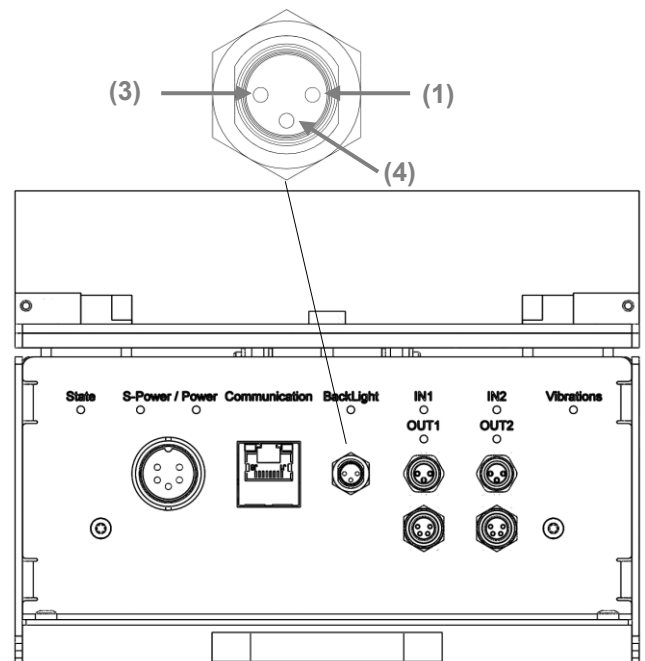

Figure 2-11 : Backlight synchronization

**NOTE :**



The Asycube Backlight illumination time corresponds to the length of the pulse signal.

### 2.4.5. Digital input 1 and 2

A standard M8 three-pins male cable enables to read two different signal, it must be connected as follows :

Pin	Signal
(1)	+24VDC OUT (sensor power supply)
(3)	0V GND
(4)	Input (+24VDC)

Connector type (on asycube side) :  
M8, 3P, female

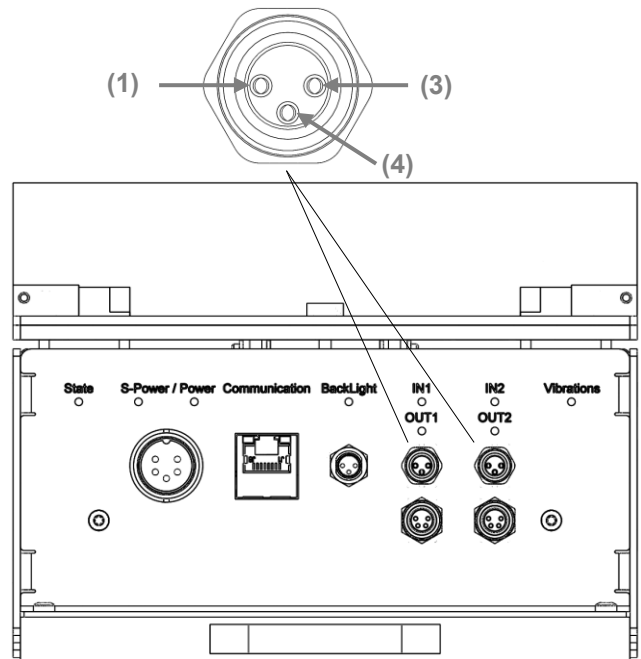

Figure 2-12 : Digital input

### 2.4.6. Digital output for hoppers 1 and 2

A standard M8 four-pins male cable enables to transmit digital output signal and analog output signal to hopper. It must be connected as follows :

Pin	Signal	Hopper
(1)	0V GND	Analog Output 1
(2)	0...10VDC	
(3)	0V GND	Digital Output 1
(4)	+24VDC	

Connector type (on asycube side) :  
M8, 4P, female

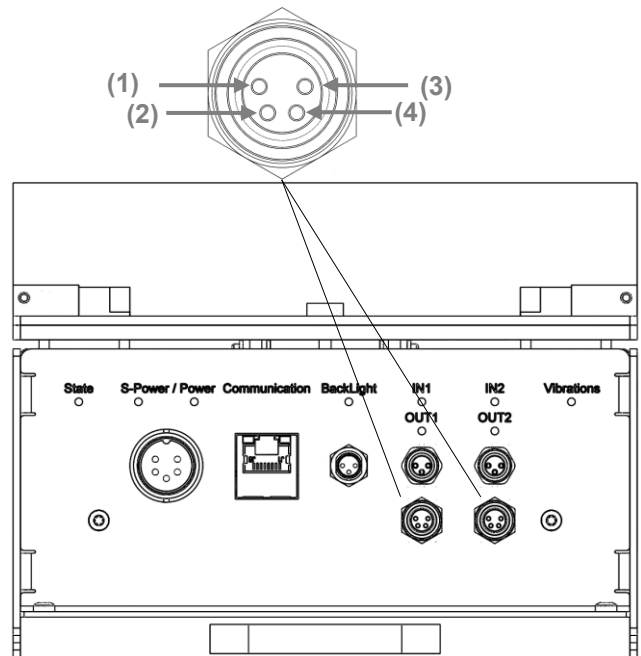



Figure 2-13 : Digital output for hoppers

	Asycube Largo A5 - Asyri SA Operating Manual	© Copyright Asyri S.A.
Description	v1.21	FO 32.03.118

## 2.5. Mechanical Interfaces

### 2.5.1. Attachment of the Asycube

To guarantee a proper behavior of the Asycube a tight fastening to a solid underground is necessary. The holes in the base plate of the Asycube can be used to attach it with four M6 screws.

Repeatable positioning of the Asycube can be done by using positioning pins (possible on both sides).

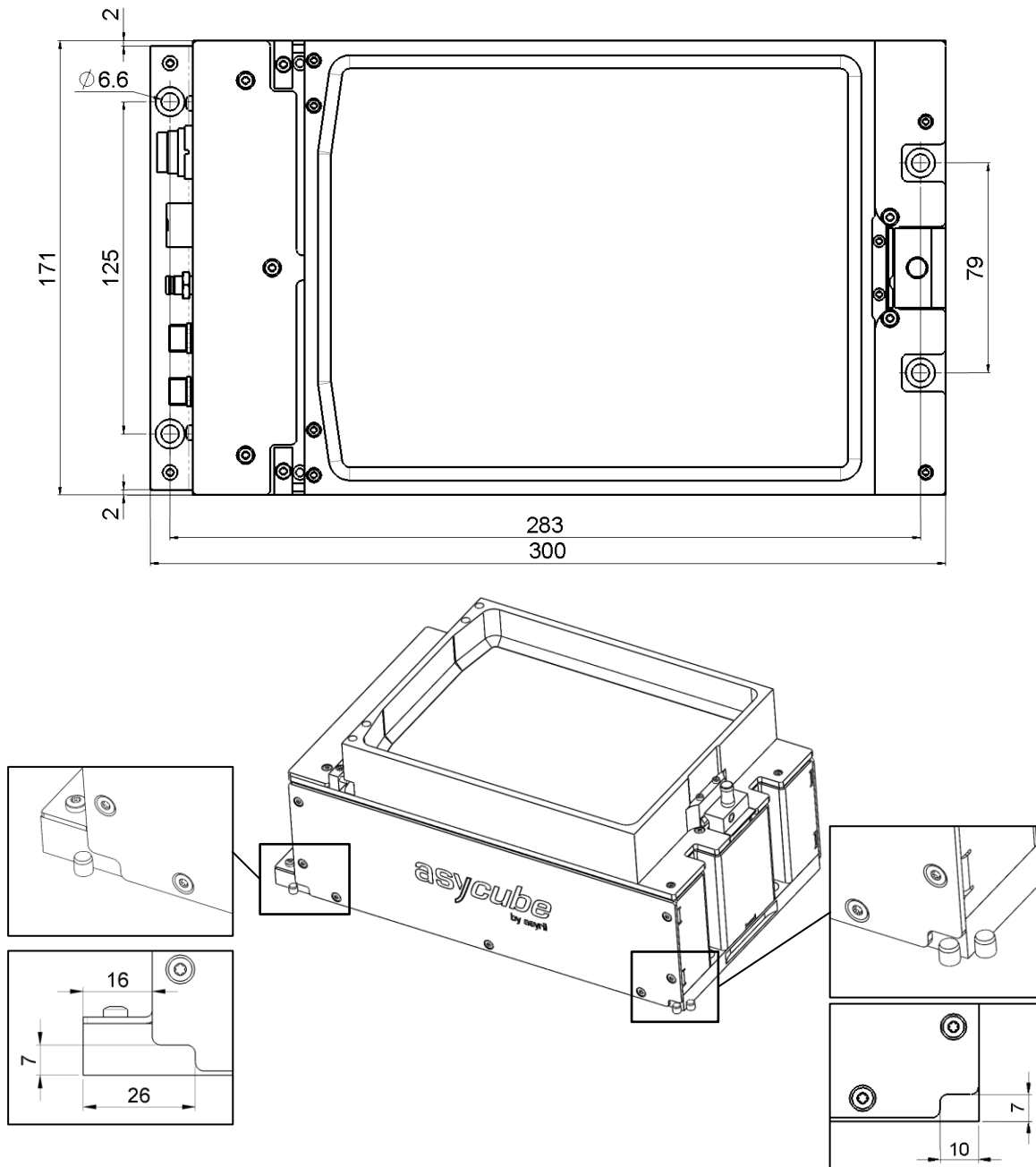

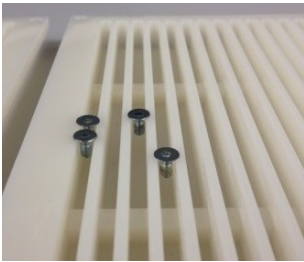
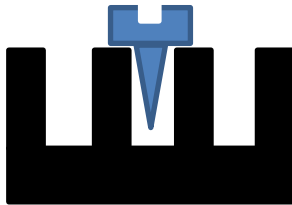
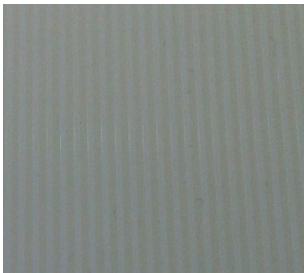
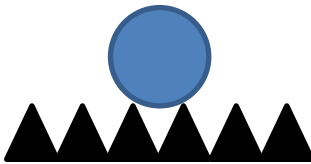



Figure 2-14 : attachment of the Asycube

## 2.6. Accessories and Optional modules

### 2.6.1. Additional platform

In order to improve the availability of certain components on the surface of the feeder, it is possible to structure the plate surface. Asyri can provide various types of plates on request. Frequently used structures on Asycube Largo A5 are as follows:

Plate type	Example – picture	Example – drawing	Advantage
<b>Plane</b>		 Ex : Bolts	This type of plate can be used for a large variety of components mainly components with a flat surface allowing a stable resting position.
<b>Grooves (deep)</b>		 Ex : Screws, Rivets	Screw type components can be fed in vertical position when the plate is structured with deep grooves.
<b>Grooves (wide)</b>		 Ex : Cylinders, Needles	Wide grooves are useful when cylindrical components are fed. They reduce the stabilising time significantly after component displacements on the plate surface (stop the components from rolling on the surface).
<b>Grooves (narrow)</b>		 Ex : Thin washers	Narrow grooves are necessary to reduce surface contact especially for flat and light components. This reduces adhesion forces and improves the component displacements on the feeder surface. It also improves the pick-performance of the robot.

**Holes**

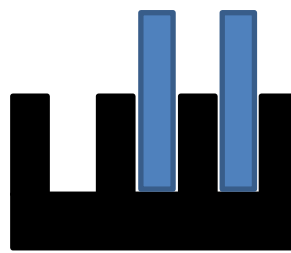
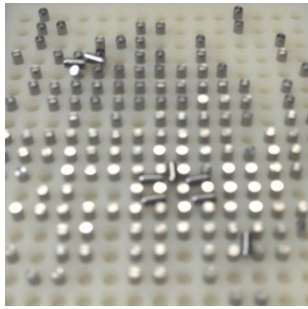

Holes are useful when cylindrical components are to be fed and presented upright.

Ex : Pins



**NOTE :**

For more information on these bespoke platforms, contact Asyri customer's service.

The table below indicates the article number of a standard (not structured platform)

Product	Part number
Asycube standard platform (not structured)	Y 660 005 776

**2.6.2. Backlight**

Following backlight are available:

Product	Part Number
Backlight Blue, wavelength 465 nm	Y 900 006 095
Backlight Green, wavelength 550 nm	Y 900 006 093
Backlight Infrared, wavelength 850 nm	Y 900 006 097
Backlight Red, wavelength 645 nm	Y 900 006 094
Backlight White, 6500 K	Y 900 006 096

If this option is ordered at the same time with the asycube, it is delivered mounted in the feeder



*For more information on the backlight color and the procedure to exchange the backlight, please refer to "4.4.1 Exchanging / installing the backlight" on page 31*



**NOTE :**

For more information on these bespoke backlights, contact Asyri customer's service.

	Asycube Largo A5 - Asyri SA Operating Manual	© Copyright Asyri S.A.
Description	v1.21	FO 32.03.118

### 2.6.3. Cables

Following cables are available:

Product	Part Number
Power cable (5m)	Y 900 006 215
Ethernet RJ45 cable (5m)	Y 601 000 218
Synchro-backlight cable (5m)	Y 900 006 223
Input Cable (5m)	Y 900 006 224
Output cable (5m)	Y 900 006 225



**NOTE :**

For more information on these bespoke cables, contact Asyri customer's service.

### 3. Transportation, handling and installation

#### 3.1. Packaging of the product, transportation and handling

The transportation of the product must be made in accordance with the specific terms indicated on the package (top, bottom and fragile ...). In addition, pay particular attention to the following points :

##### WARNING !



- Be aware of the weight and take care when transporting the system.
- Always hold the system firmly with two hands on the side bars.
- The operator should not carry heavy shipping boxes by himself.
- If the shipping box is to be left standing, it should be in a horizontal position.
- Do not climb on the shipping box.
- Do not place heavy objects, on top of the shipping box.

The Asycube is shipped in a cardboard of the following dimensions:

Largo A5	
Dimensions	550x400x300 mm
Gross weight	12 kg

**Table 3-1 : gross weight and dimensions of the product when packaged**

#### 3.2. Before unpacking

Before unpacking, look at the ShockWatch Label. As to promote zero-defect shipping, all Asyri products are shipped with a ShockWatch Label. If this is red, or if any evidence of damage during transit was to be indicated please :

- (A) request that the carrier's agent be present at the time of unpacking.
- (B) pay special attention to any damage on the exteriors of the product
- (C) If any damage has occurred, do not sign the delivery receipt and contact Asyri
- (D) In every cases, make a notation on the delivery receipt



**Figure 3-1 : ShockWatch**



##### NOTE :

If the items received do not match to your order, or are damaged, do not sign the receipt, and contact Asyri as soon as possible.



### 3.3. Unpacking instructions



**NOTE**

Do not remove the Asycube from its packaging until you are ready to install it.



**WARNING !**

**Keep the packaging material and the shipment box in case of return**

Locate the identification sticker at the back of the product and ensure that the product you have received is the appropriate one.

Important information is on this sticker; such as the power consumption or the serial number that you will need for any kind of correspondence with Asyрил.

Asyрил SA – Switzerland www.asyрил.ch Article N0 : xxx xxx xxx Type: ACUBE-LA5 Input voltage 24VDC <b>Serial N0: xxxxxx</b>
--

**Figure 3-2 : Product sticker**

The product key gives the product designation as follows:

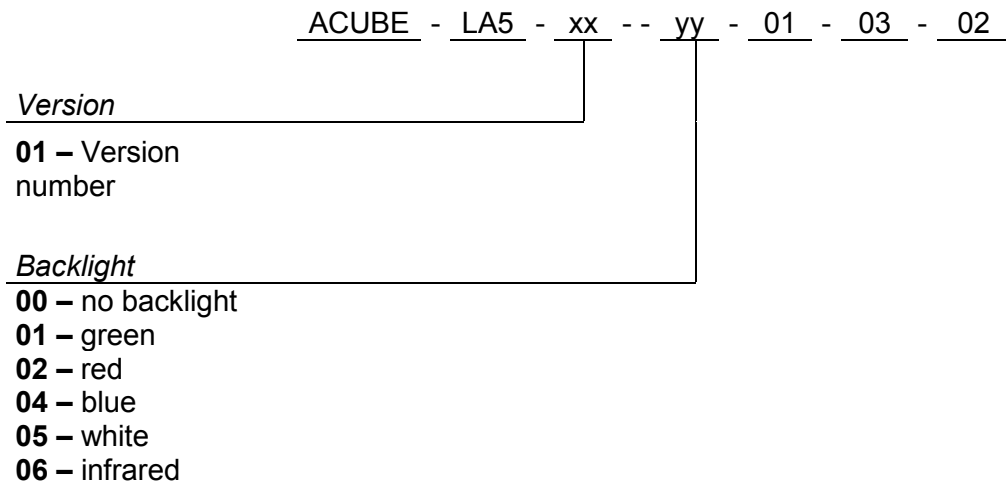

**Figure 3-3 : product key**

	Asycube Largo A5 - Asyri SA Operating Manual	© Copyright Asyri S.A.
Transportation, handling and installation	v1.21	FO 32.03.118

### 3.4. Installation and storage environment

#### WARNING !



The Asycube must be mounted on a smooth, flat and strong surface. Ensure yourself that the Asycube is not submitted to mounting flexure. Failure to do so would degrade feeder performance.

#### 3.4.1. Installation environment

The Asycube can be used under following conditions:

- The asycube is IP20
- Working temperature: +5°C to +40°C
- Humidity: 30% to 80%max. non-condensing

#### WARNING !



In the case humidity or temperature variation, note that it might affect the global performances of the Asycube.

- Avoid extreme electromagnetic waves, ultraviolet rays and radiation.
- Avoid using the product in a place where the main unit or controller may be exposed to water or oil droplets.
- Clean room application: cleanliness class ISO7

#### WARNING !



Do not use the product in an atmosphere of corrosive gases. Rust may form and reduce the structural strength of the product.

#### 3.4.2. Storage environment

The storage environment should be similar to the operating environment. In addition, you should protect the Asycube against dust

	Asycube Largo A5 - Asyri SA Operating Manual	© Copyright Asyri S.A.
Maintenance and reparation	v1.21	FO 32.03.118

## 4. Maintenance and reparation

### 4.1. Safety precautions

#### 4.1.1. General safety precautions

**WARNING !**



There are no user serviceable parts inside the product. Contact Asyri or your local supplier to effect maintenance. In cases of non respectation, the product guarantee will expire.

**DANGER !**



**Do not operate the system when it is damaged. Please ensure yourself before use that no visual defects are detected.**

**DANGER !**



**Power down the system and unplug it from the mains before any kind of maintenance.**

**DANGER !**



**Do not pour water onto the product. Spraying water over the product, washing it with water or using it in water may cause the product to malfunction, resulting in injury, electric shock, fire, etc.**

#### 4.1.2. Specific warnings

**WARNING !**



Be sure that the platform is unloaded before any kind of maintenance.

### 4.2. Personnel responsible for maintenance or reparation

Maintenance operation must be done by personnel who has a working knowledge of the system, nevertheless, we can define three kind of staff :

- (A) Maintenance technician without any specific formation from Asyri
- (B) Maintenance technician with a specific formation from Asyri
- (C) Technician from Asyri's customer service

Make sure that the person who will be working on the maintenance has received and read this manual, and will be able to work in the manner specified in the following sections. All personnel must observe the safety precautions listed in this manual.

### 4.3. Maintenance



#### WARNING !

For any kind of maintenance, always use Asyrl products.

#### 4.3.1. Periodic maintenance schedule

Our Asycube are largely maintenance-free, however, simple inspections should be done at regular intervals to ensure optimum performances, and safety operating of your product.

Item		Period	Reference
General	Cleaning of the machine	Week	
	Visual check of electrical harness	Year	
	Visual check and cleaning of the plate	Week	Section 4.3.3
specific process	It is the customer's responsibility to schedule the maintenance of his specific process	/	/
Backlight	Visual check	Month	

**Table 4-1 : periodic maintenance schedule**

#### NOTE :



The information given in the "Table 4-1 : periodic maintenance schedule" is only informative, maintenance and times must be modified by the operator in accordance with your particular system, its operating environment and the amount of usage.

### 4.3.2. Remove the platform module

**DANGER!**



Be sure that the backlight is off before removing the platform module.



Risk of crushing. Do not place your finger between the platform and the locking mechanism

**Step 1** Pull out the integrated tool (A) and move it away for freeing the platform (B)

**Step 2** Take the platform out (C)  
Release the tool – the mechanism as reverse operation from step 1 to let it goes to its initial position

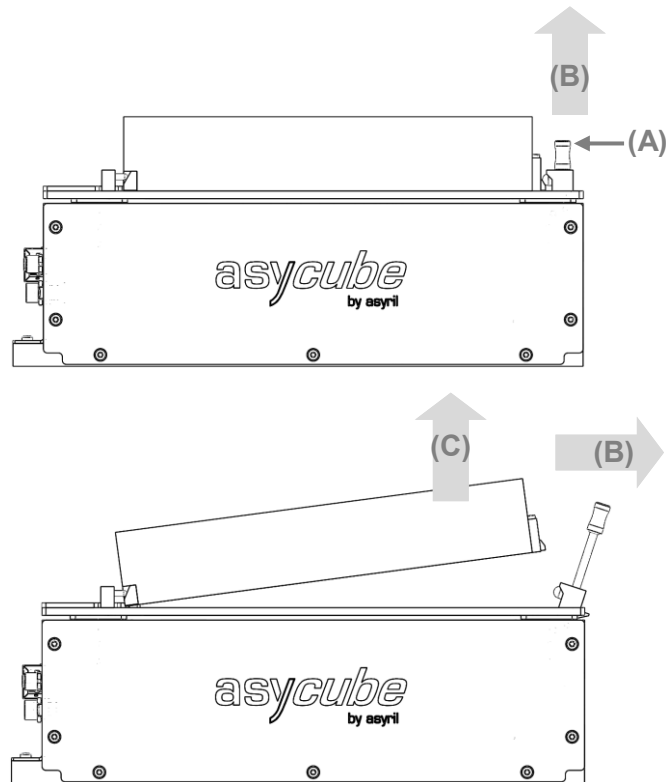

Figure 4-1 : remove the platform

### 4.3.3. Control and Cleaning of the platform

Material needed :

- Lint-free cloth
- isopropanol alcohol

**Step 1** Control the surface state of the platform (A) and be particularly careful to the following points :

- Big claws
- Dirt or spotted surface
- Oily or greasy surface

**WARNING :**



If the surface is damaged so as to obstruct vision or the behavior of parts, its replacement must be proceeded

**Step 2** Clean the surface of the platform

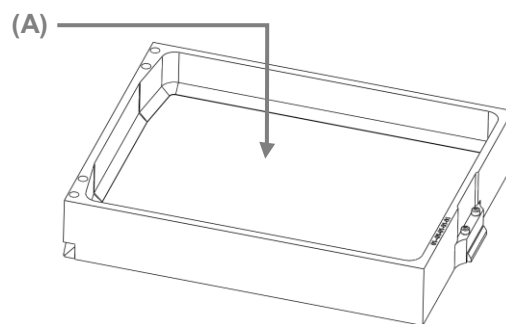

Figure 4-2 : Platform

## 4.4. Reparation

This section gives a list of the replaceable parts in the system with their part numbers. The product must be returned to the manufacturer for any repair work. In exceptional cases, and after acceptance of Asyrl S.A. this work can be performed on the customer's site by trained personnel as defined in section 4.2.



### **WARNING !**

For any kind of reparation, always use Asyrl products.

Two kind of parts are defined :

- (A) Part way that might be changed after 1 year (wear part)
- (B) Part way that might be changed after 5 years

Part name	Type	Part Number
Backlight assembly Blue	B	Y 900 006 107
Backlight assembly Green	B	Y 900 006 106
Backlight assembly Infrared	B	Y 900 006 109
Backlight assembly Red	B	Y 900 006 105
Backlight assembly White	B	Y 900 006 108
Asycube platform	A	Y 660 005 776

**Table 4-2 : Replaceable parts**

#### 4.4.1. Exchanging / installing the backlight

**DANGER!**



Be sure that all power sources and other cables to the unit are disconnected before changing the backlight.

Material needed :

- New backlight assembly ordered from asyrl
- Flat wrench size 5.5
- Torx key size 10

**Step 1** Unscrew the 7 screws on both sides (A) and (A') and remove the two side covers

Use an torx key size 10

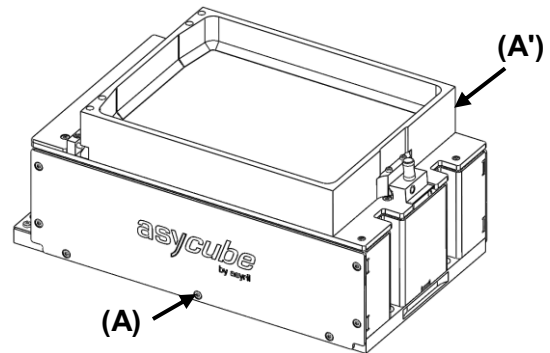

**Step 2** On both sides, unscrew the four bolts (B)

Use a flat wrench size 5.5

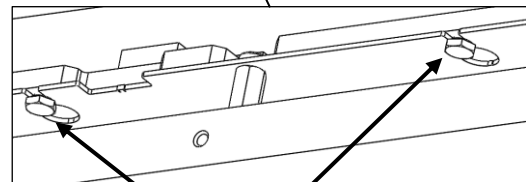
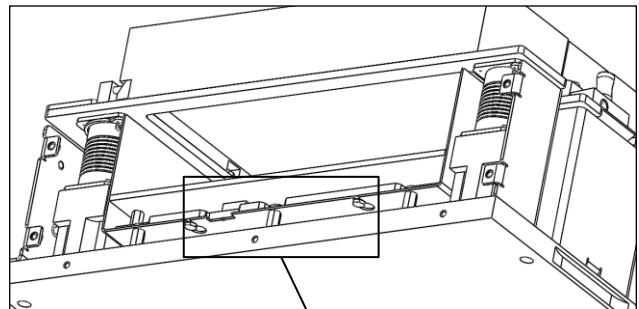

(B)

**Step 3**

Unplug the backlight connector (C)

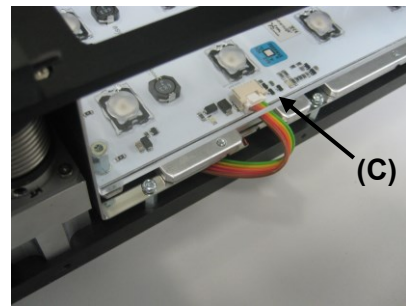

Remove the old backlight (D) and insert the new backlight (E)

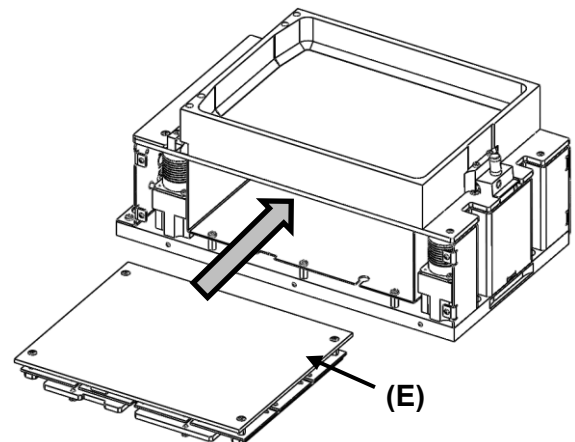
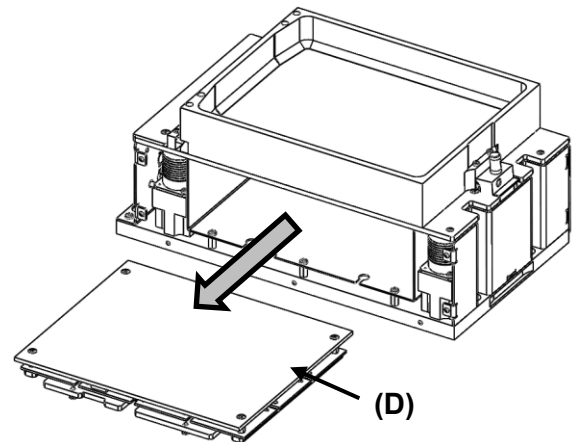



**Step 5** Align the backlight module flush with the mirror support **(F)** and tighten the four bolts **(G)**  
*Use a flat wrench size 5.5*

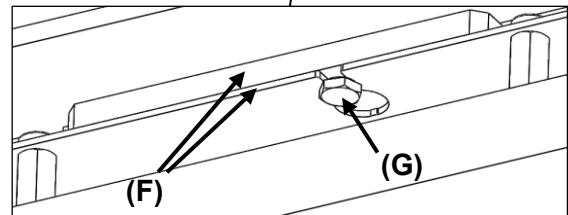
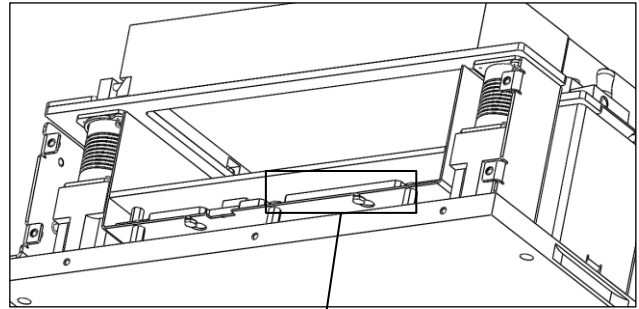

**Step 6** Plug the backlight connector **(H)**

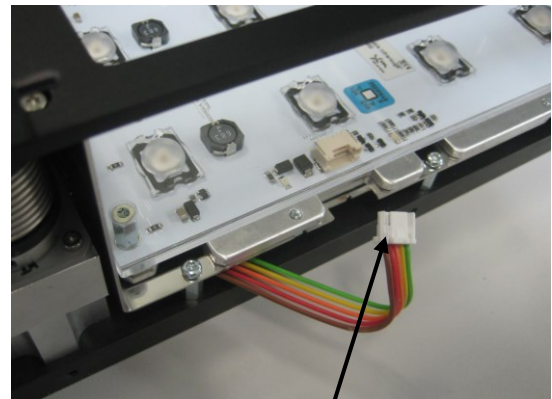

**(H)**

**Step 7** Remount the covers **(I)** and **(I')** on both sides

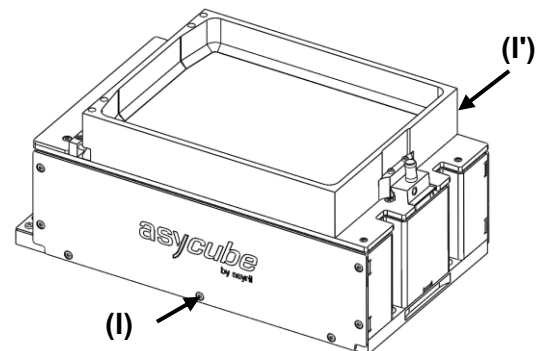

#### 4.4.1.1. Configure the Asycube with a new backlight color

You can set the color of the backlight in the Asycube. It is useful for example to be able to adapt interfaces depending of the color or depending if there is no backlight.

- With HMI

To modify the parameter, use the following procedure:

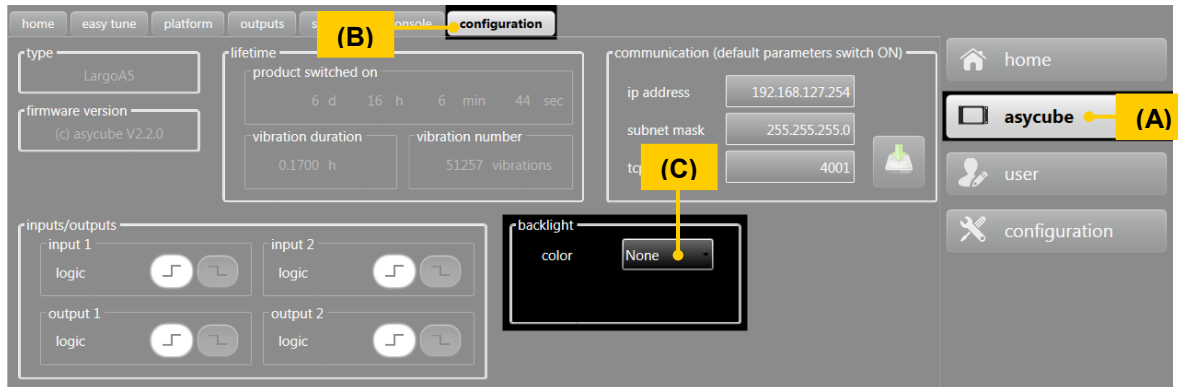

**Figure 4-3 : change backlight color in HMI**

Ref.	Designation	Description
(A)	"Asycube" button	Press this button to display the Asycube screen.
(B)	"Asycube configuration" button	Press this button to display the Asycube configuration tab.
(C)	"Color" select box	This select box allows selecting the color of the backlight. If "None" is chosen, backlight tab and backlight switches disappear.

For more information about the HMI, please refer to the user interface documentation.

- With dll

To modify the parameter with dll, use this function:

SetBacklightColor(BacklightColor color, string password)

The password is important, because to write this parameter, you need to be logged in the firmware as Integrator. Password is 1234.

For more information on the DLL, please refer to the user guide documentation.

- Using tcp commands

To modify the parameter with TCP commands, use this sequence of commands:

Command	Function	More informations
1	{#1,wp7=1234}	Login in integrator mode
2	{#1,wp97=1}	0: Green 1: Red 2: Blue 3: IR 4: UV 5: White 99: None
3	{#1,df}	Save configuration in flash memory
4	{#1,wp7=1}	Logout

#### 4.4.2. Recover IP address using default IP address

The following procedure explains how to reboot the Asycube on the default IP address, subnet mask and tcp port number to be able to modify IP address, subnet mask and tcp port number when they are unknown and cannot be founded. Following this procedure, you are able to connect on the Asycube with default parameters and then modify unknown parameters.

**Step 1** Unscrew the 3 screws on both sides (A) and remove the cover

Use an torx key size 10

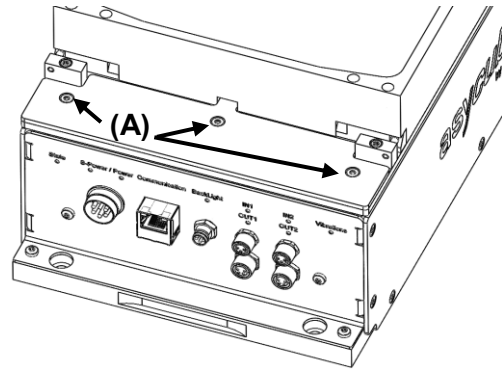

**Step 2** Place selector 1 in "off" position (B)

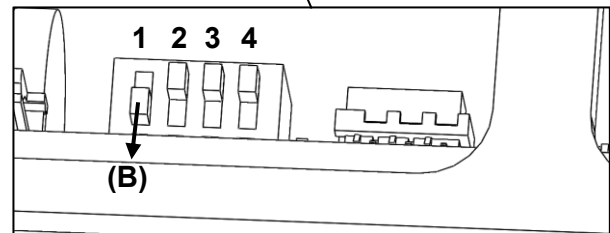
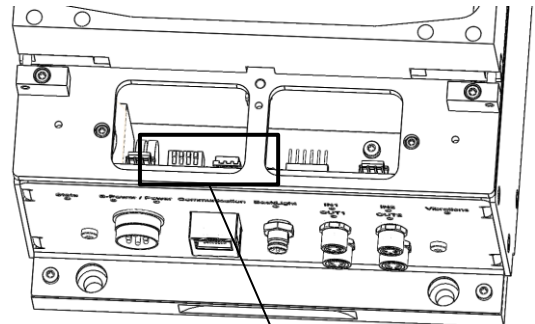

**Step 3** Disconnect and reconnect the power cable (or switch off and switch on the power on the Asycube).

The AsyCube will take default parameters at startup :

**IP: 192.168.127.254**

**SubnetMask: 255.255.255.0**

**TCP Port: 4001**

**Step 4** Parameters in memory can now be modified (by direct access with commands to the AsyCube, by functions in dll or by Asycube configuration page in HMI (see relative documentations for more details).

**Step 5** When parameters are defined as desired, replace selector 1 in position ( C).

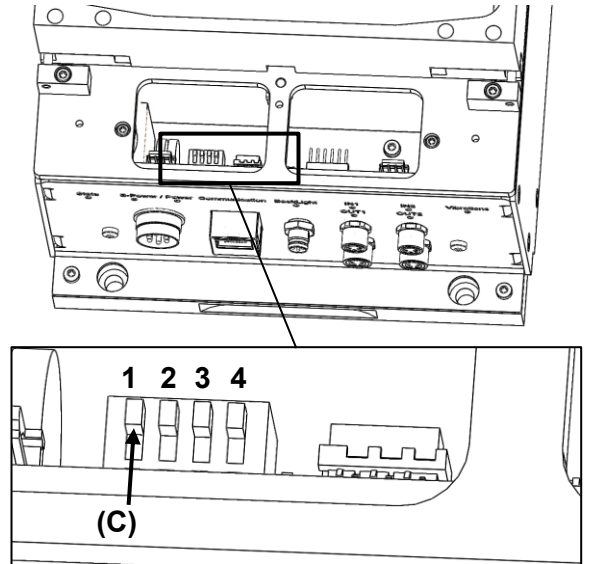

**Step 6** Disconnect and reconnect the power cable (or switch off and switch on the power on the Asycube).

The Asycube will take parameters defined at startup.

**Step 7** Replace the cover and screw the 3 screws on both sides (A)

Use an torx key size 10

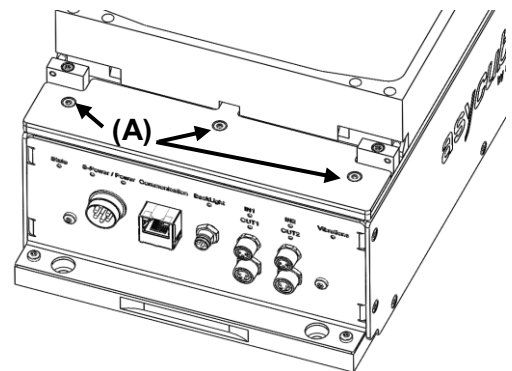

<b>asyril</b> experts in mechatronics	Asycube Largo A5 - Asyri SA Operating Manual	© Copyright Asyri S.A.
Maintenance and reparation	v1.21	FO 32.03.118

## 4.5. Technical support

### 4.5.1. For better service ...

You have read the related manuals without finding answers to your questions ? Before calling the support service, note the following information for your system:

- serial number and product key of your material
- software version
- alarm or error message displayed on the screen

### 4.5.2. Contact

You can find lot of information on our website : [www.asyri.ch](http://www.asyri.ch)

You can also contact us by mail or through our web-site contact form :

[support@asyri.ch](mailto:support@asyri.ch)

+41 26 653 7190

## 5. Annexes

### 5.1. Condition of use of backlight

<b>CONDITIONS OF USE OF PRODUCTS TPL VISION</b>	
<b>TABLE OF CALCULATION</b>	
<b>THE REQUIREMENTS BELOW ARE IN STRICT COMPLIANCE WITH THE STANDARD</b>	
<b>NF EN 62471 "LAMPS PHOTOBIOLOGICAL SAFETY"</b>	
<small>THIS DOCUMENT ISN'T A CERTIFICATE AND CAN'T BE USED AS WELL BUT ONLY AS PRECONISATIONS FOR USERS</small>	

Sample subjected to calculations	Product reference	Date
1 brick 8 leds 200x150 green	SPE1341-AB2	17/10/2014

**Info Source to LEARN**

	Exposure time to the direct source	0,25 Secondes
1	Wavelength	525 nm
	Color temperature	K
2	Total Angle	150 Degrés
3	<i>For the visible:</i>	
	Output Intensity	candelas
	Output Power	150 lumens
3	<i>For the Non-Visible:</i>	
	Power density	0,000 W/m <sup>2</sup>
4	Number of LED	8 LEDs
5	If you use a lense, Efficiency in candela per lumen	2,5 Cd/lm

**CALCULATION from information about the Source**

Calculation of Maximum Permitted Exposure (EMP) :	25,456 W/m <sup>2</sup>
	13665,66445 lm/m <sup>2</sup>
<b>Calculation of power density for visible source :</b>	
Surface illuminated by the source :	0,437567409 m <sup>2</sup>
Power of one LED =	150 Lumen
Power densité for one LED :	342,804324 lm/m <sup>2</sup>
<b>Calculation of power density for a non-visible source :</b>	
Surface illuminated by the source :	0,4376 m <sup>2</sup>
Power Density for one LED :	0,000 W/m <sup>2</sup>

**CALCULATION for the safety of persons**

<b>Source Hazardous :</b>	
Power density for a visible source :	2742,434592 lm/m <sup>2</sup>
Power density for a non-visible source :	0,000 W/m <sup>2</sup>

<b>NOMINAL DISTANCE TO AVOID OCULAR HAZARD (DNRO)</b>	
<b>FOR AN EXPOSURE TIME OF (Seconde): 0,25</b>	
Minimum safe distance in this case*	<b>128 mm</b>

\* Consider as Hazard Zone Optics (NRA), or area within which the irradiance or radiant exposure exceeds the maximum permissible exposure (MPE), all positions within an envelope of the remote DNRO.

**informations :**

Exposure time is fixed to 0,25s for this calculation table, which is the latency blink of the eye duration.  
Output power : the maximum output power for the type of LED used in the product is 150 lumens under 350mA.  
Number of Led : In the worst case, we can imagine that the person can see entirely the light.



**CONDITIONS OF USE OF PRODUCTS TPL VISION**  
**TABLE OF CALCULATION**  
**THE REQUIREMENTS BELOW ARE IN STRICT COMPLIANCE WITH THE STANDARD**  
**NF EN 62471 "LAMPS PHOTOBIOLOGICAL SAFETY"**  
THIS DOCUMENT ISN'T A CERTIFICATE AND CAN'T BE USED AS WELL BUT ONLY AS PRECONISATIONS FOR USERS

Sample subjected to calculations	Product reference	Date
1 brick 8 leds 200x150 red	SPE1341-AC2	17/10/2014

**Info Source to LEARN**

<b>Exposure time to the direct source</b>	<b>0,25</b> Secondes
<b>1</b> Wavelength	<b>630</b> nm
Color temperature	K
<b>2</b> Total Angle	<b>150</b> Degrés
<b>3</b> <i>For the visible:</i>	
Output Intensity	candelas
Output Power	<b>80</b> lumens
<i>For the Non-Visible:</i>	
Power density	0,000 W/m <sup>2</sup>
<b>4</b> Number of LED	<b>8</b> LEDs
<b>5</b> If you use a lense, Efficiency in candela per lumen	<b>2,5</b> Cd/lm

**CALCULATION from information about the Source**

Calculation of Maximum Permitted Exposure (EMP) :	25,456 W/m <sup>2</sup>
	4607,380507 Lm/m <sup>2</sup>
<b>Calculation of power density for visible source :</b>	
Surface illuminated by the source :	0,437567409 m <sup>2</sup>
Power of one LED =	80 Lumen
Power densité for one LED :	182,8289728 lm/m <sup>2</sup>
<b>Calculation of power density for a non-visible source :</b>	
Surface illuminated by the source :	0,4376 m <sup>2</sup>
Power Density for one LED :	0,000 W/m <sup>2</sup>

**CALCULATION for the safety of persons**

<b>Source Hazardous :</b>	
Power density for a visible source :	1462,631782 lm/m <sup>2</sup>
Power density for a non-visible source :	0,000 W/m <sup>2</sup>

<b>NOMINAL DISTANCE TO AVOID OCULAR HAZARD (DNRO)</b> <b>FOR AN EXPOSURE TIME OF (Seconde): 0,25</b>	
<b>Minimum safe distance in this case*</b>	<b>161 mm</b>

\* Consider as Hazard Zone Optics (NRA), or area within which the irradiance or radiant exposure exceeds the maximum permissible exposure (MPE), all positions within an envelope of the remote DNRO.

**informations :**

Exposure time is fixed to 0,25s for this calculation table, which is the latency blink of the eye duration.  
Output power : the maximum output power for the type of LED used in the product is 80 lumens under 350mA.  
Number of Led : In the worst case, we can imagine that the person can see entirely the light.



**CONDITIONS OF USE OF PRODUCTS TPL VISION**  
**TABLE OF CALCULATION**  
**THE REQUIREMENTS BELOW ARE IN STRICT COMPLIANCE WITH THE STANDARD**  
**NF EN 62471 "LAMPS PHOTOBIOLOGICAL SAFETY"**  
THIS DOCUMENT ISN'T A CERTIFICATE AND CAN'T BE USED AS WELL BUT ONLY AS PRECONISATIONS FOR USERS

Sample subjected to calculations	Product reference	Date
1 brick 8 leds 200x150 Bleu	SPE1341-AF2	17/10/2014

**Info Source to LEARN**

<b>Exposure time to the direct source</b>	<b>0,25</b> Secondes
<b>1</b> Wavelength	<b>470</b> nm
Color temperature	K
<b>2</b> Total Angle	<b>150</b> Degrés
<b>3</b> <i>For the visible:</i>	
Output Intensity	candelas
Output Power	<b>39</b> lumens
<i>For the Non-Visible:</i>	
Power density	0,000 W/m <sup>2</sup>
<b>4</b> Number of LED	<b>8</b> LEDs
<b>5</b> If you use a lense, Efficiency in candela per lumen	<b>2,5</b> Cd/lm

**CALCULATION from information about the Source**

Calculation of Maximum Permitted Exposure (EMP) :	25,456 W/m <sup>2</sup>
	1582,15708 Lm/m <sup>2</sup>
<b>Calculation of power density for visible source :</b>	
Surface illuminated by the source :	0,437567409 m <sup>2</sup>
Power of one LED =	39 Lumen
Power densité for one LED :	89,12912424 lm/m <sup>2</sup>
<b>Calculation of power density for a non-visible source :</b>	
Surface illuminated by the source :	0,4376 m <sup>2</sup>
Power Density for one LED :	0,000 W/m <sup>2</sup>

**CALCULATION for the safety of persons**

<b>Source Hazardous :</b>	
Power density for a visible source :	713,0329939 lm/m <sup>2</sup>
Power density for a non-visible source :	0,000 W/m <sup>2</sup>

<b>NOMINAL DISTANCE TO AVOID OCULAR HAZARD (DNRO)</b> <b>FOR AN EXPOSURE TIME OF (Seconde): 0,25</b>	
<b>Minimum safe distance in this case*</b>	<b>191 mm</b>

\* Consider as Hazard Zone Optics (NRA), or area within which the irradiance or radiant exposure exceeds the maximum permissible exposure (MPE), all positions within an envelope of the remote DNRO.

**informations :**

Exposure time is fixed to 0,25s for this calculation table, which is the latency blink of the eye duration.  
Output power : the maximum output power for the type of LED used in the product is 39 lumens under 350mA.  
Number of Led : In the worst case, we can imagine that the person can see entirely the light.

<h2 style="margin: 0;">CONDITIONS OF USE OF PRODUCTS TPL VISION</h2> <h3 style="margin: 0;">TABLE OF CALCULATION</h3> <p style="margin: 0;"><b>THE REQUIREMENTS BELOW ARE IN STRICT COMPLIANCE WITH THE STANDARD NF EN 62471 "LAMPS PHOTOBIOLOGICAL SAFETY"</b></p> <p style="margin: 0; font-size: small;">THIS DOCUMENT ISN'T A CERTIFICATE AND CAN'T BE USED AS WELL BUT ONLY AS PRECONISATIONS FOR USERS</p>	
--	--

Sample subjected to calculations <b>1 brick 8 leds 200x150 infrared</b>	Product reference <b>SPE1341-AD2</b>	Date <b>17/10/2014</b>
--	---	---------------------------

**Info Source to LEARN**

	Exposure time to the direct source	<b>10</b> Secondes
<b>1</b>	Wavelength	<b>850</b> nm
	Color temperature	<b>K</b>
<b>2</b>	Total Angle	<b>150</b> Degrés
<b>3</b>	<i>For the visible:</i>	
	Output Intensity	candelas
	Output Power	lumens
	<i>For the Non-Visible:</i>	
	Power density	1,028 W/m <sup>2</sup>
<b>4</b>	Number of LED	<b>8</b> LEDs
<b>5</b>	If you use a lense, Efficiency in candela per lumen	<b>2,5</b> Cd/lm

**CALCULATION from information about the Source**

Calculation of Maximum Permitted Exposure (EMP) :		19,953 W/m <sup>2</sup>
	Source Non-Visible	lm/m <sup>2</sup>
<b>Calculation of power density for visible source :</b>		
Surface illuminated by the source :	Source Non-Visible	m <sup>2</sup>
Power of one LED =	Source Non-Visible	Lumen
Power densité for one LED :	Source Non-Visible	lm/m <sup>2</sup>
<b>Calculation of power density for a non-visible source :</b>		
Surface illuminated by the source :		0,4376 m <sup>2</sup>
Power Density for one LED :		8,227 W/m <sup>2</sup>

**CALCULATION for the safety of persons**

<b>Source Hazardous :</b>		
Power density for a visible source :	Source Non-Visible	lm/m <sup>2</sup>
Power density for a non-visible source :		8,227 W/m <sup>2</sup>

<b>NOMINAL DISTANCE TO AVOID OCULAR HAZARD (DNRO)</b>		
<b>FOR AN EXPOSURE TIME OF (Seconde):</b>		
		<b>10</b>
Minimum safe distance in this case*	<b>183</b>	<b>mm</b>

\* Consider as Hazard Zone Optics (NRA), or area within which the irradiance or radiant exposure exceeds the maximum permissible exposure (MPE), all positions within an envelope of the remote DNRO.

**informations :**

Exposure time is fixed to 10s for this calculation table, which is the max duration according to the standard compliance.  
Output power : the maximum output power for the type of LED used in the product is 450mW under 350mA.  
Number of Led : In the worst case, we can imagine that the person can see entirely the light.

## 5.2. CE Certificate

### Declaration of incorporation

according to the EU Machinery Directive 2006/42/EC, Annex II 1. B  
for partly completed machinery



---

<p><b>Manufacturer</b></p> <p>Asyri SA ZI Le Vivier 22 CH - 1690 Villaz-St-Pierre</p>	<p><b>Person established in the Community authorised to compile the relevant technical documentation</b></p> <p>Jean-Baptiste Berset Asyri SA ZI Le Vivier 22 CH - 1690 Villaz-St-Pierre</p>
---	--

**Description and identification of the partly completed machinery**

Product / Article	ACUBE-LA5
Type	Asycube Largo A5
Serial number	14380000 à 50000000
Function	Smooth vibration feeder for ultra efficient component distribution

**It is declared that the following essential requirements of the Machinery Directive 2006/42/EC have been fulfilled.**

1.3., 1.3.7, 1.5.1, 1.5.10, 1.5.11, 1.6.1

**It is also declared that the relevant technical documentation has been compiled in accordance with part B of Annex VII.**

**It is expressly declared that the partly completed machinery fulfils all relevant provisions of the following EU Directives.**

2004/108/EC	Directive 2004/108/EC of the European Parliament and of the Council of 15 December 2004 on the approximation of the laws of the Member States relating to electromagnetic compatibility and repealing Directive 89/336/EEC
2006/42/EC	Directive 2006/42/EC of the European Parliament and of the Council of 17 May 2006 on machinery, and amending Directive 95/16/EC (recast) (1)

**Reference to the harmonised standards used, as referred to in Article 7 (2)**

EN ISO14121-2:2008	Safety of machinery - Risk assessment - Part 2: Practical guidance and examples of methods
EN ISO 11553-1:2005	Safety of machinery - Laser processing machines - Part 1: General safety requirements (ISO 11553-1:2005)
EN 60204-1:2006/AC:2010	Safety of machinery - Electrical equipment of machines - Part 1: General requirements
EN ISO 12100:2010-11	Safety of machinery - General principles for design - Risk assessment and risk reduction (ISO 12100:2010)
EN ISO 13732-1:2008	Ergonomics of the thermal environment - Methods for the assessment of human responses to contact with surfaces - Part 1: Hot surfaces (ISO 13732-1:2006)
EN 349:1993+A1:2008	Safety of machinery - Minimum gaps to avoid crushing of parts of the human body

The manufacturer or his authorised representative undertake to transmit, in response to a reasoned request by the national authorities, relevant information on the partly completed machinery. This transmission takes place  
- in electronic format

This does not affect the intellectual property rights!

**Important note! The partly completed machinery must not be put into service until the final machinery into which it is to be incorporated has been declared in conformity with the provisions of this Directive, where appropriate.**

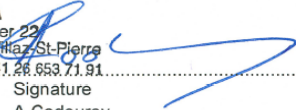
<p>Villaz-St-Pierre, 2014-11-10</p> <p>Place, Date</p>	<div style="text-align: center;">  <p>asyril SA Z.I. du Vivier 22 CH-1690 Villaz-St-Pierre Tél. +41 26 653 71 90. Fax +41 26 653 71 91</p> </div> <div style="text-align: right;">  <p>Signature A. Codourey Director</p> </div>
--	---

Page 1/1

	Asycube Largo A5 - Asyri SA Operating Manual	© Copyright Asyri S.A.
Annexes	v1.21	FO 32.03.118

Review history

Rev.	Date	Author	Comments
1.0	03.10.2014	BeJ	Initial Version
1.1	06.11.2014	BeJ	Pt 2.4.2 TBTP modified in PELV, pt 1.4 CE certification
1.2	23.04.2015	HsJ	Changes for pinout connectors and power max current.
1.21	16.06.2015	HsJ	Remove 5V TTL synchro backlight, because it's not guaranteed.

This document is the property of Asyrl S.A. and may not be copied or circulated without permission. The information contained in this document is subject to change without notice for the purpose of product improvement.



asyril sa  
z.i. le vivier  
ch-1690 villaz-st-pierre  
switzerland  
tel. +41 26 653 71 90  
fax +41 26 653 71 91  
info@asyril.ch  
www.asyril.ch