

CP-AW2519NM

ULTIMATE究極 INTERACTIVE



ULTIMATE INTERACTIVE WXGA LCD PROJECTOR

The Ultimate Short Throw series provides high performance projection in small spaces. By integrating Hitachi Starboard software with advanced projector technology, the CP-AW2519NM can deliver the complete interactive experience on any flat surface. The compact, lightweight chassis makes this projector easy to install and flexible to use. With the bundled wall-mount and optional table top kit you can project onto any existing whiteboard, wall or tabletop.

Interactive

- Pen-based single touch interactive system with Hitachi Starboard™ software
- Rapid, precise response to user input
- WXGA resolution (1280 x 800)
- 80" (2m) image from only 53cm*
- 2500 ANSI lumens (Bright Mode)
- 2000:1 contrast ratio
- Full connectivity including HDMI
- Perfect Fit – adjust all four corners and sides of the image individually to achieve a distortion free image
- Table top mount facility
- 10W speaker
- Anti theft features

Cost of ownership

- Extended Hybrid Filter life – up to 5000 hour cleaning cycle
- Extended lamp life – up to 5000 hours in Normal Mode
- Virtually maintenance free
- Easy setup and installation
- Wall mount included in the box

Advanced Network Features

- Full connectivity including 1 x RJ-45
- Configure and control projector via network with a web browser
- Projector management via SNMP
- Content via LAN
- AMX Device Discovery
- Messenger
- PJ Link™
- Network Bridge

Environment

- The extended Hybrid Filter life means reduced electronic waste and reduced maintenance visits, resulting in an overall reduction in carbon footprint

Hitachi have formulated an "Environmental Vision" to contribute towards building a sustainable society through business and product development.

Our goal is to develop life-enhancing technology that will contribute to and realise a truly sustainable society for current and future generations.

Starboard™ software requirements

- CPU: Intel Pentium 4 1.8GHz or faster
- RAM: minimum 1GB
- Operating system (OS): Windows XP 32bit/Windows Vista 32bit/Windows 7 32/64bit (the latest service pack must be applied) (Tablet PC Edition and Server Edition are not supported)
- Software required: Internet Explorer 6.0/7.0/8.0 (for viewing Online Help and using Internet search functions) PowerPoint 2002/2003/2007/2010 (for viewing PowerPoint documents) Microsoft DirectX 9.0c/Windows Media Player 9 or above (for using movie features) Adobe Flash Player 10 (for using Flash object)
- Others: DVD drive, video card with hardware overlay feature (for using movie features)

*from centre of mirror to screen



HITACHI

Inspire the Next

CP-AW2519NM Technical Specifications

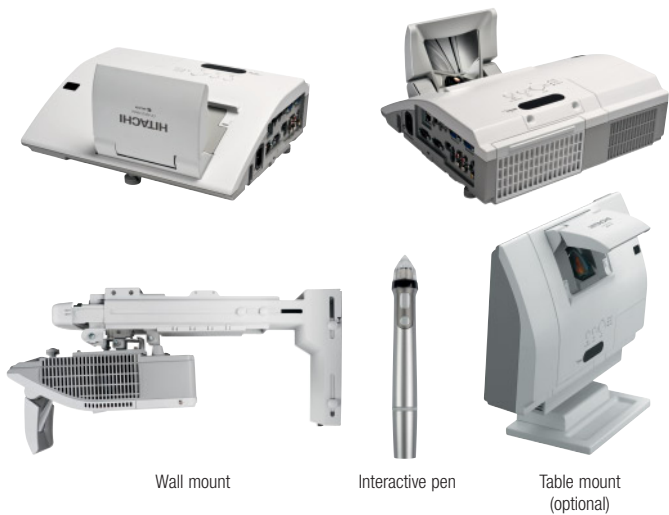

Wall mount

Interactive pen

Table mount (optional)

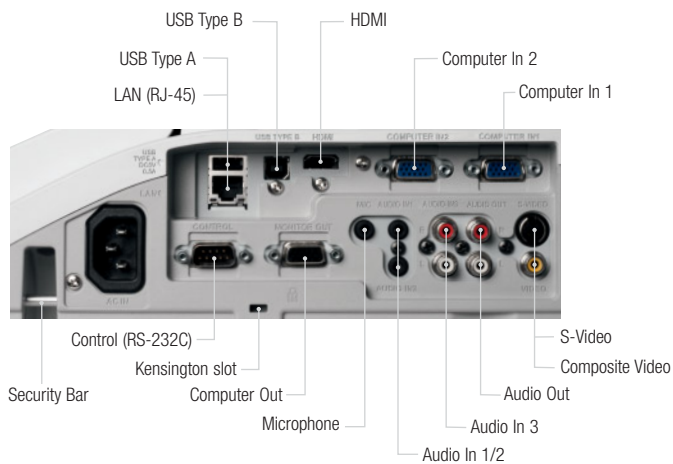

USB Type B

HDMI

USB Type A

Computer In 2

LAN (RJ-45)

Computer In 1

Control (RS-232C)

Kensington slot

Security Bar

Computer Out

Microphone

Audio In 3

Audio In 1/2

S-Video

Composite Video

Audio Out

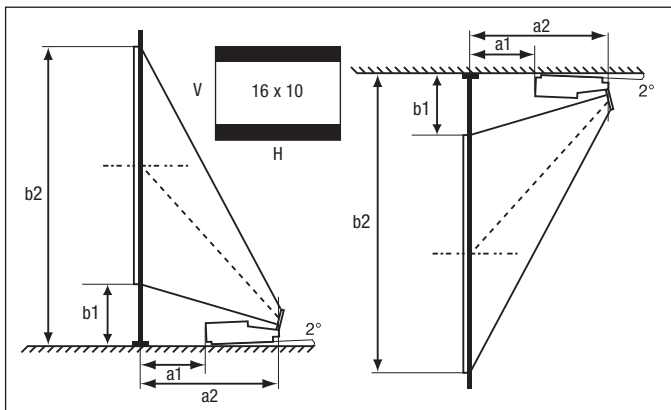

Throw distance (from the top of the lens)

Screen size (diagonal)	H x V		a1	a2	b1	b2
	(m)	(m)				
60" (1.5m)	1.3	0.8	0.120	0.426	0.295	1.102
70" (1.8m)	1.5	0.9	0.188	0.494	0.332	1.274
80" (2.0m)	1.7	1.1	0.256	0.562	0.369	1.446
90" (2.3m)	1.9	1.2	0.324	0.631	0.407	1.618
100" (2.5m)	2.2	1.3	0.392	0.699	0.444	1.791

Starboard™ software special requirements

For Webcam playback and capturing feature

- DV (Digital video, DV cameras, D-VHS)
- Capture devices which support DirectShow (with WDM drivers)

For Conference host feature

- CPU: Intel Core 2 Duo 2.0GHz or faster
- Free hard drive space: 2GB or more
- RAM: 2GB or more
- Others: TCP/IP 54Mbps or above

OPTICAL

Interactive sensor (IR and ultrasonic waves system)	Single touch, an interactive pen is required
LCD Panel	0.59" (1.5cm) P-Si TFT x3
Resolution	WXGA (1280 x 800)
Brightness	Bright Mode 2500 ANSI Lumens Normal Mode 1700 ANSI Lumens
Colour light output	2500 ANSI Lumens
Contrast Ratio	2000:1
Lens	Free shaped lens and motorised free shaped mirror
Lamp Wattage	210W UHB
Lamp Life	3000 Hours (Bright Mode)/5000 Hours (Normal Mode)*
Distance to Width Ratio (:1)	0.3:1 (fixed)
Diagonal Display Size	60~100" (152~254cm)
Number of Colour	8 Bit/colour, 16.7M colours
Keystone	Fixed, 5.2:-1 upward shift

COMPATIBILITY

Computer Compatibility	IBM Compatible VGA, SVGA, XGA, WXGA, WXGA+, SXGA, WSXGA+, UXGA, MAC 16"
Video Compatibility	NTSC/PAL/SECAM/PAL-M/PAL-N/NTSC4.43 SDTV: 525i(480i), 525p(480p), 625i(576i) HDTV: 750p (720p@60Hz), 1125i(1080i@50/60Hz), 1125p(1080p@50/60Hz) DCC2B

FEATURES

Speakers	10W Mono
Basic functions	Freeze, Magnifying, Blank, Auto adjustment, Search
Picture adjustments	Equalizing Gamma Correction, 2-3 pull down, Progressive Scan, Noise Reduction, Perfect Fit
Digital keystone	Manual V Keystone correction, Manual H Keystone correction
Advanced features	PC-less drawing function (optional wireless tablet required), MyScreen, My Memory, My Button by remote control, Blackboard/Whiteboard mode, Daytime Mode, Input source naming (English), Resolution setting, Template, Saving mode, AudioPass through, My Text
Outward	Easy Lamp replace from Top, Rear intake air filter
Power on & off	Quick ON, Direct ON, Direct Off
Security systems	PIN Security Lock, MyScreen Password Lock, Transition Detector, My Text Password Lock, Key Lock (key pad, remote control), Kensington slot, Security bar, Lens door lock
Network	Configure and control projector via web browser, receive alerts via e-mail, projector management via SNMP, Scheduling, My Image, displaying text data transferred via the network, Command Control via network, AMX Device Discovery, Messenger, PJ Link™, Network Bridge, content via LAN, MAC address displayed on the side
OSD Languages	English, French, German, Spanish, Italian, Norwegian, Dutch, Korean, Japanese, Portuguese, Simplified Chinese, Traditional Chinese, Swedish, Russian, Finnish, Polish, Turkish, Arabic, Persian, Czech, Danish, Hungarian, Romanian, Slovenian, Croatian, Greek, Lithuanian, Estonian, Latvian, Thai, Portuguese (Brazil), Indonesian, Vietnamese

CONNECTIONS

Digital Input	1 x HDMI
Computer Input	2 x 15-pin Mini D-sub
Computer Output	1 x 15-pin Mini D-sub
Video Input	1 x RCA Jack (for composite) 1 x S-Video Jack
Audio Input	2 x Component D-sub (shared with analogue RGB) 2 x Stereo Mini Jack 1 x pair RCA (L/R) 1 x Microphone Jack
Audio Output	1 x pair RCA (L/R)
Control	1 x 9-pin D-sub for RS232 control
USB	1 x USB type A for PC-less presentation and optional wireless pen tablet 1 x USB type B for mouse control
Wired network	1 x RJ-45

POWER

Power Supply	AC100-120V/220-240V, auto switching
Power Consumption	300 W
Power Consumption in Standby	<0.3W

PHYSICAL

Dimensions (W x H x D)	345 x 102 x 303mm (excluding feet and extrusions when mirror is closed)
Weight	4.1Kg
Noise Level	34dB (Bright Mode)/28dB (Normal Mode)
Air Filter	Hybrid

MISCELLANEOUS

Lamp indicator light, Power light, Ceiling mount image, Rear projection image, Serial number label on side

CERTIFICATION

UL60950-1/C-UL, FCC Part 15 Class A, CE, AS/NZS CISPR22 Class A

ACCESSORIES SUPPLIED

Remote control with batteries, RGB cable, power cord, cable cover, security label, user manual (detail & concise), wall mount (HAS-K250), interactive pen with batteries, USB cable (5m), Starboard™ software and manual, Application DVD (Starboard™ software)

OPTIONAL ACCESSORIES

Replacement lamp	DT01251
Table top stand	TT-251

WARRANTY

Projector warranty	3 Years
Lamp warranty	Please consult your local Hitachi agent for the latest offer



Wedgwood AV Ltd
Audio visual supplier since 1996

Wedgwood AV Ltd

Specialise in the supply of audio visual equipment to UK medical, MOD, education and businesses

Tel: 01754 769967 / 0800 018 9967

FREE Repeat Signage Standalone digital signage software for Windows with every order over £500+VAT purchased from Wedgwood AV Ltd in 2015

Full product list FREE AV guides



LCD monitors

Wedgwood are giving away Repeat Signage Standalone Edition worth £145+VAT with any products with a total order value of over £500+VAT purchased during 2015 from Wedgwood AV Ltd. sales@wedgwood-group.com (Order value £1,000 +VAT will receive two software licences; £1,500+VAT three licences).

Repeat Signage helps you get your message across, to promote your products or services. You can display still and moving images, scrolling text messages, RSS feeds (such as the BBC weather or your local news), show webcam or web browser, add audio, PowerPoint scheduler, Flash clocks, and even display pictures which text. [See 2 minute video](#). [Trial download](#)

Contact us - how to order

For a quotation or to place your official purchase order and receive your FREE Repeat Signage digital signage software please telephone 01754 769967 or fax 01754 768036 Email sales@wedgwood-group.com [Special offers](#)

Wedgwood AV Ltd - 01754 769967 www.wedgwood-group.com



Mount solutions



Touch screens



Digital signage



Medical monitors



Lecterns



Audio



Whiteboards



Projectors



Projector lamps



Projector lenses



Projector screens