

Quick®

CE REV 002

nautical equipment evolution

CHAIN COUNTER

CHC 1102 M



GB

User's Manual

CHAIN COUNTER CHC 1102 M



- Pag. 4 **CHARACTERISTICS AND INSTALLATION**
- Pag. 5 **INSTALLATION** - Installing the laps sensor
- Pag. 6 **INSTALLATION** - Installing the magnet - Installing the sensor
- Pag. 7 **INSTALLATION** - Installing the socket
- Pag. 9 **INSTALLATION** - Installing the support - inserting the chain counter into the support
- Pag. 10 **INSTALLATION** - Installing the support - extracting the chain counter from the support
- Pag. 11 **INSTALLATION** - Electric connections
- Pag. 12 **INSTALLATION** - Installing the terminals
- Pag. 13 **INSTALLATION** - Chain counter calibration
- Pag. 14 **CHAIN COUNTER OPERATION** - Main window
- Pag. 15 **CHAIN COUNTER OPERATION** - Windlass electric drive
- Pag. 16 **CHAIN COUNTER OPERATION** - Monitoring
- Pag. 17 **CHAIN COUNTER OPERATION** - Winch mode
- Pag. 18 **SETTING THE CHAIN COUNTER**
- Pag. 19 **SETTING THE CHAIN COUNTER** - The structure of the menus
- Pag. 20 **SETTING THE CHAIN COUNTER** - Settings menu - Counter reset / Functions
- Pag. 22 **SETTING THE CHAIN COUNTER** - Settings menu - Personal set
- Pag. 23 **SETTING THE CHAIN COUNTER** - Settings menu - Date and time
- Pag. 24 **SETTING THE CHAIN COUNTER** - Settings menu - Language / Calibration
- Pag. 25 **SETTING THE CHAIN COUNTER** - Settings menu - Calibration / Gypsy lap
- Pag. 26 **SETTING THE CHAIN COUNTER** - Settings menu - Automatic calibration
- Pag. 27 **SETTING THE CHAIN COUNTER** - Settings menu - Utility
- Pag. 29 **SETTING THE CHAIN COUNTER** - Settings menu - CAN configuration
- Pag. 30 **SYSTEM ERRORS AND FAULTS**
- Pag. 33 **MAINTENANCE - TECHNICAL DATA**



CHAIN COUNTER CHC 1102 M

Our vast experience in the world of sailing has allowed us to design and develop the chain counter CHC 1102 M whose performance is widely superior to those of similar instruments available on today's market. The chain counter CHC 1102 M allows the windlass to be activated to get the anchor aweigh or lower the anchor providing the exact measure of the chain lowered.

Other important advantages which the chain counter offers, are:

- Simple user-friendly interface.
- Information displayed in 5 different languages.
- Automatic lowering function.
- Up alarm function.
- Can also be used in winch operations.
- Chain speed displayed.
- Supply voltage displayed.
- Equipped with clock/calendar.
- Depth of chain lowered shown in meters or feet.
- Graphic LCD display screen that can be easily read at various angles.
- Backlight display screen with 8 brightness levels.
- 8 different display contrast levels can be set.
- Automatic display contrast compensation according to environmental temperature.
- Universal power supply (12/24Vdc).
- Backlight illuminated function keys.
- Equipped with led torch.
- CAN BUS interface for data transfer.
- Capable of operating in a wide range of ambient temperatures.
- Water-proof housing

INSTALLATION

BEFORE ATTEMPTING TO USE THE CHAIN COUNTER CAREFULLY READ AND BECOME FAMILIAR WITH THE CONTENTS OF THIS USER'S MANUAL. IF IN DOUBT, CONTACT YOUR NEAREST DEALER OR QUICK® CUSTOMER SERVICE.

The Quick® chain counter has been designed and constructed solely for the tasks and purposes given in this User's manual. Quick® company shall not be held responsible for any direct or indirect property damage caused by inappropriate use of the chain counter, incorrect installation or possible errors present in this manual.

THE OPENING OF THE CHAIN COUNTER BY UNAUTHORIZED PERSONNEL MAKES THE WARRANTY VOID.

THE PACKAGE CONTAINS: chain counter - support - laps sensor kit - 150 ohm terminator - gasket - screws for securing the outlet - drilling templates - warranty card - this user's manual.



INSTALLING THE LAPS SENSOR

Chain counter installation takes place in three steps: installation of the laps sensor on the windlass, mounting of the chain counter and electrical connections.

Quick® windlasses

All Quick® windlasses come with a laps sensor suitable for use with chain counter CHC 1102 M.

Other windlasses

In order for the chain counter to measure the exact length of the chain, it has to count the number of revolutions completed by the gear that drives the chain (gypsy). A laps sensor kit is supplied with the chain counter. This kit includes a cylindrical magnet, a magnetic field sensor and two plastic adaptors to be used to secure the sensor in place. The magnet is to be secured to the gypsy while the magnetic sensor is to be fixed to the windlass base.

The standard installation procedure is described below. Unfortunately we cannot describe a procedure applicable to all types of situation. Adapt this procedure to satisfy your own individual requirements.

EXAMPLES OF LAPS SENSOR INSTALLATION

vertical windlasses

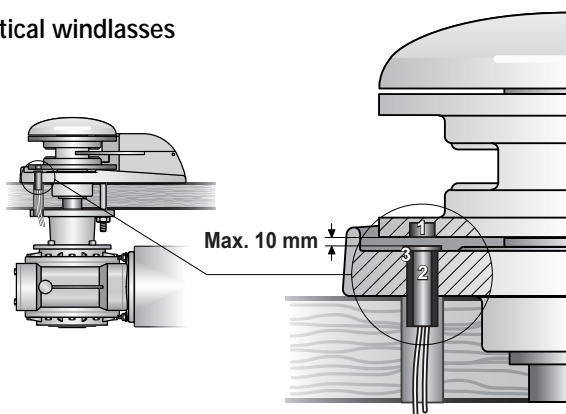

horizontal windlasses

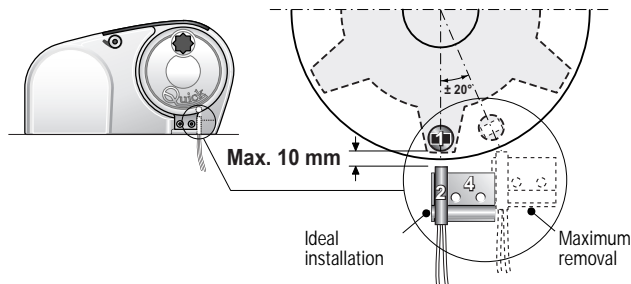

- 1 MAGNET
- 2 SENSOR
- 3 ADAPTOR
- 4 ADAPTOR



INSTALLING THE MAGNET

Take the gypsy off the windlass (consult the user's manual that deals with the windlass). Find the spot most suitable for the magnet housing based on the following criteria:

- The magnet should not be installed in an area that the chain passes through (outer areas).
- The location should be preferably made in the area where the gypsy is thickest (in order not to weaken the structure).
- Regarding horizontal windlasses, make sure it is located near the edge of the gypsy.
- Regarding vertical windlasses, make certain the sensor is installed on the base at the circumference "traced" by the magnet.
- The magnet can protrude from the gypsy; make certain it does not interfere with the base or sensor.
- The magnet should be as close to the sensor as possible.

Once the hole has been drilled, glue the magnet inside it. Make sure the glue covers the part of the magnet still visible. Use glue designed for metals, resistant to brackish ambients and capable of withstanding temperatures ranging from -30 to $+80$ °C. Generally speaking, epoxy-based bi-component glues satisfy these requirements.

Several magnets can be installed on the same gypsy to increase the precision with which the chain counter reads (not provided). Place any additional magnets around the same circumference equally spaced apart.

INSTALLING THE SENSOR

Locate the most suitable position to secure the sensor to the base according to the following criteria:

- The sensor should not be installed in an area that the chain passes through.
- If holes are made in the base, make sure they do not interfere with normal operation, do not weaken the structure or cause lubricant to flow out (windlasses with oil-bathed gears).
- Regarding vertical windlasses, make certain the sensor can be installed on the base at the circumference "traced" by the magnet.
- The magnet should be as close to the sensor as possible.

Use the plastic adaptors provided to secure the sensor. Use a sheath to protect the sensor cables.

Once installed, make sure the laps sensor works properly. Place the gypsy so that the magnet is aligned with the sensor and check electrical continuity between the two sensor cables. When the magnet is moved away from the sensor electrical continuity should no longer be present.



INSTALLING THE SOCKET

The standard installation procedure is described below.

Unfortunately we cannot describe a procedure applicable to all types of windlasses.

Adapt this procedure to satisfy your own individual requirements.

Find the spot most suitable for the socket based on the following criteria:

- The socket is to be installed in an area where it can be easily reached by the user.
- Select a clean, smooth, flat spot.
- A rear point that provides access to the socket's fixing surface must be present for installation and maintenance purposes.
- Leave enough space free behind the installation spot to conveniently run the socket's cable.
- The back of the socket must be protected against contact with water and moisture.
- Pay careful attention when drilling the panel or parts of the boat. This hole should not weaken or break/crack the boat's structure.

The chain counter meets standard EMC (electromagnetic compatibility).

In any case correct installation is fundamental in order not to affect its performance or interfere with operation of instruments found near it.

For this reason the chain counter must be at least:

- 25 cm away from the compass.
- 50 cm away from any radio receivers.
- 1 m away from any radio transmitters (except for SSB).
- 2 m away from any radio transmitters SSB.
- 2 m away from the path of the radar beam.



Installing the socket

After selecting the area where the instrument is to be installed, perform the steps given below:

- Place the drilling template (provided) on the surface where the socket will be installed.
- Mark the center of each hole.
- Make the hole the socket's cable will run through with a 25 mm (1") hollow cutter.
- Remove the template and any burrs present in the hole.
- Place the seal at the base of the socket.
- Run the cable through the hole made.
- Secure the socket tightening the 4 screws provided.

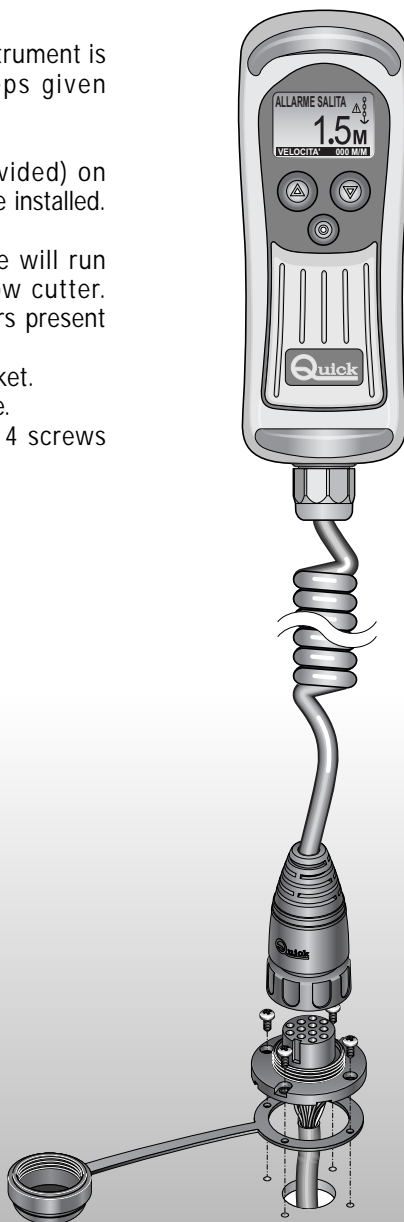



INSTALLING THE SUPPORT

The standard installation procedure is described below. Unfortunately we cannot describe a procedure applicable to all the situations.

Adapt this procedure to satisfy your own individual requirements.

Find the spot most suitable for the support based on the following criteria:

- The support must be positioned so that it can easily be reached by the operator.
- Choose a clean, smooth, flat location.
- Check that the back of the panel into which the screws of the support will be inserted is free from passing cables, tubes, etc.
- Take particular attention when screwing into the panels or parts of the boat. The screws must not weaken or cause the breakage of structural elements of the boat.
- Place the support onto the chosen surface.
- Fix the support with the 2 screws provided.

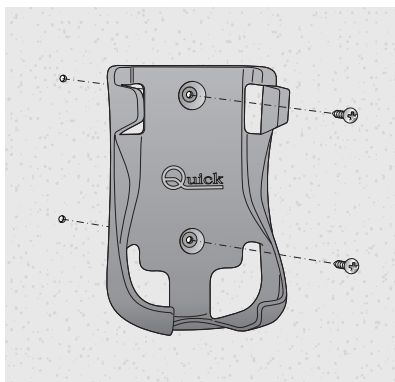

INSERTING THE CONTROL PANEL INTO THE SUPPORT

To insert the control panel into the support, follow the instructions in the illustrated sequence:

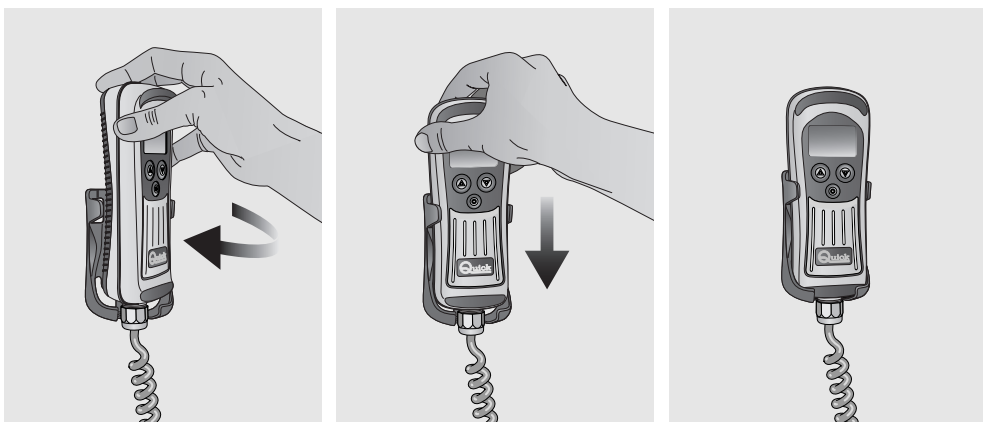

Insert the control panel slightly rotated into the support and continue the rotation until the control panel is parallel with the support.

Push the control panel down until it is fully inserted into the support.

**EXTRACTING THE CONTROL PANEL FROM THE SUPPORT**

To extract the control panel from the support, follow the instructions in the illustrated sequence:

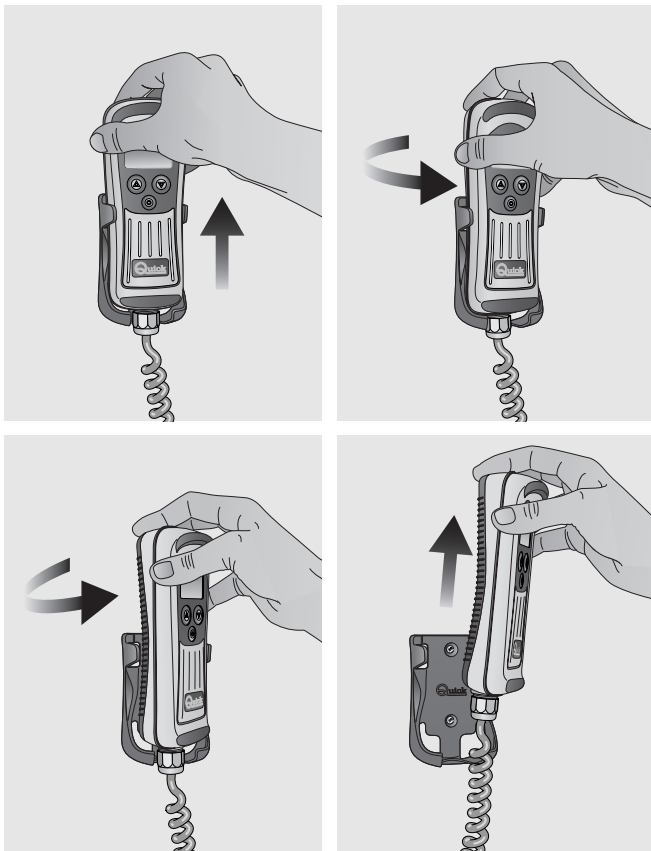

Slide the control panel from its support by raising it a few centimetres, rotate in either direction and then extract it from the support by raising it.



ELECTRIC CONNECTIONS

Connecting the instrument

After installing the socket as instructed above, proceed as directed below:

- Turn the protective cover's ring nut counter-clockwise and take it out.
- Insert the instrument's plug into the socket, being careful to plug it in the right direction.
- Turn the plug's ring nut clockwise until it is fully tightened.

Disconnecting the instrument

- Turn the plug's ring nut counter-clockwise and take it out.
- Cover the socket with the cover provided, turning the ring nut clockwise

 **ATTENTION:** make certain the socket is covered with the cover provided when the instrument is disconnected.

THE WIRING DIAGRAM

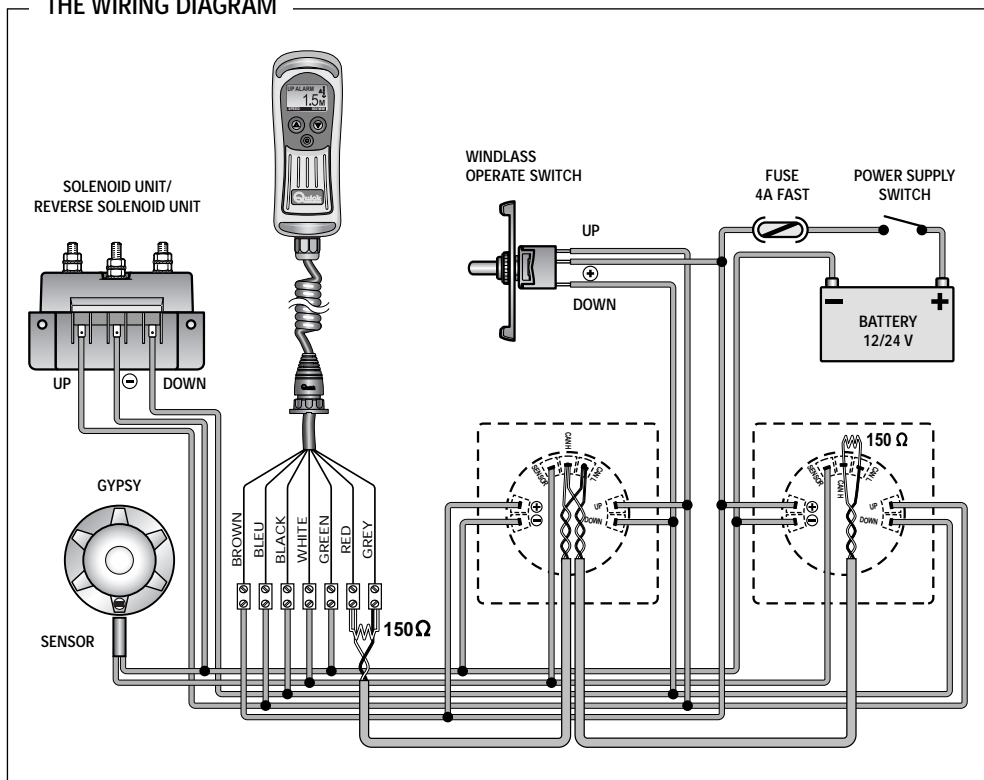



INSTALLING THE TERMINALS

In order for data to be correctly transmitted when several chain counters are employed, terminator (150 ohm) must be installed.

The terminator should be connected between signals CANH and CANL of the first and last chain counter included in the network, as illustrated in the figure below:

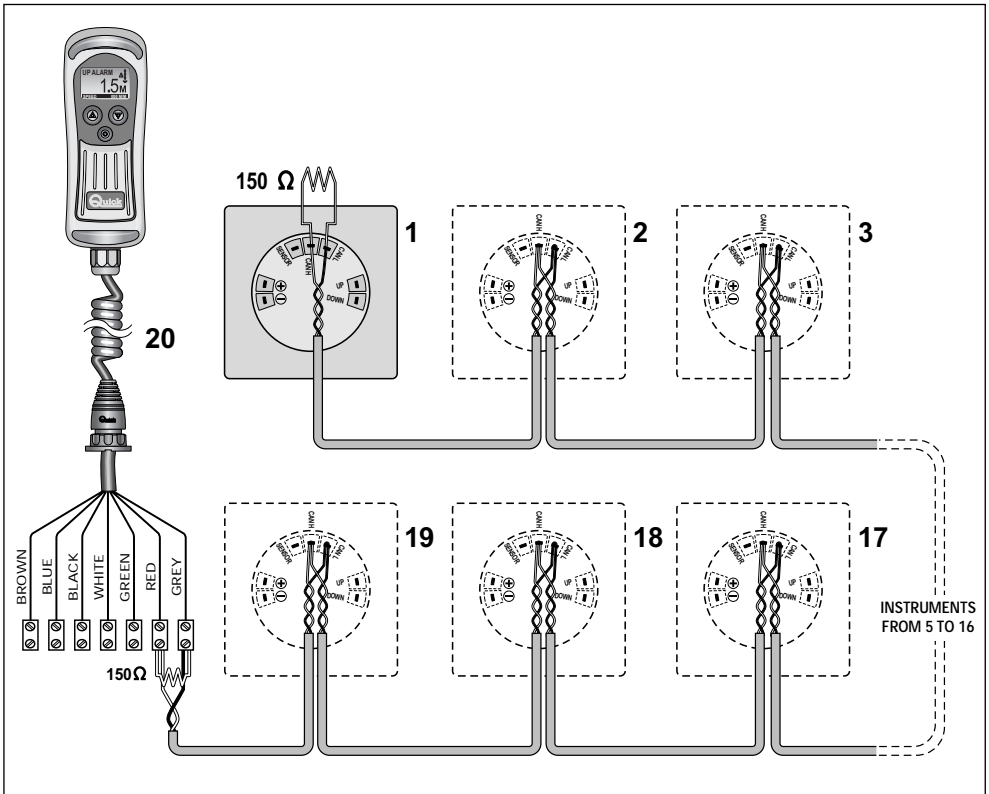

Do not install the terminator if just one chain counter is used.



CHAIN COUNTER CALIBRATION

Before using the chain counter, either the manual or automatic calibration procedure has to be effected.

The calibration procedure consists of setting the following data: unit of measurement used by the chain counter, length of chain unwound each gypsy lap and number of magnets installed on the gypsy.

To calibrate, go to menu CALIBRATION or AUTO CALIBRATE (see chapter SETTING THE CHAIN COUNTER).

MULTIPLE CHAIN COUNTERS

The chain counter is equipped with a CAN BUS data interface that allows several chain counters to be connected and information to be exchanged (CAN network).

A MASTER/SLAVE network structure is used, i.e. there is only one main chain counter (MASTER) and all the other chain counters are secondary (SLAVE).

The network must have at least one MASTER chain counter.

If there is more than one anchor chain counter, instrument CHC1102 M must be set as SLAVE. Instrument CHC 1102 M should be set as MASTER only if it is the only instrument present.

The task of the MASTER chain counter is to align the length of the chain lowered and operating parameters of all the SLAVE chain counters.

The MASTER therefore is used as a reference for all the other SLAVE chain counters.

If a parameter in a menu for a SLAVE chain counter is modified, the change is actually made to the MASTER chain counter that will automatically update all the SLAVE chain counters (except for menu PERSONAL SET, UTILITY and CAN CONFIG that contain particular functions and parameters for every single chain counter not shared in network with the other chain counters).

The MASTER chain counter should be on even if the commands to the windlass are transmitted from SLAVE chain counters or other windlass operation switches.

If the MASTER chain counter should malfunction, one of the SLAVE chain counters can be set up as the MASTER.

Before using the chain counters on the CAN network, make sure the MASTER and SLAVE settings of all the chain counters are correct and that the network works in a trouble-free manner.



CHAIN COUNTER OPERATION

Three elements are employed between user and counter interface:

A GRAPHIC DISPLAY SCREEN, CONTROL KEYS AND BUZZER.

The **display screen** shows the measure of chain lowered, state of the chain counter along with other information. The **control panel** comes with three keys. The two largest keys are used to move the anchor up (▲, UP key) or down (▼, DOWN key), move within the system menus or modify the value of parameters. The middle key (● SELECT) is used to turn the torch on and off, select the monitoring mode, go to the system menus or confirm parameters. The **buzzer** signals when the keys have been pressed or when it is necessary to call the user's attention. Use the switch on the power supply line to turn the chain counter on and off.



When the chain counter is turned on, the following window is displayed for a few seconds:



Where XXXXX is the serial number, YY is the week of production and ZZ is the year the chain counter was produced.

When the chain counter is turned on the first time, the menu used to select the language in which messages are displayed appears. The selected language can be changed later on.

MAIN WINDOW

Once the initialization procedure has been completed, the main window is displayed:

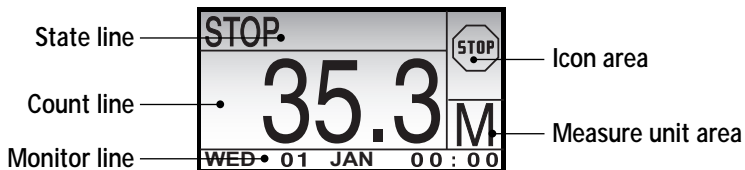

This window is divided into the following sections:

Count line - The length of the chain lowered is shown in this area.

Measure unit area - The unit of measurement currently being used is shown in this area. The values may be displayed in "M" for meters and "FT" for feet.

State line - Messages regarding the state of the chain counter or faults detected are shown here.

Icon area - The icons regarding the state of the chain counter or faults detected are shown here.

Monitor line - The following information may be displayed here, depending on the selections made by the user: date and time, instrument power supply voltage, speed of chain movement and winch mode.



WINDLASS ELECTRIC DRIVE

Getting the anchor aweigh

To get the anchor aweigh press key 5 (UP). Hold the key pressed until the anchor reaches the desired position and then release it.

While moving up, the chain counter displays a window similar to the one shown below:



It is also possible to get the anchor aweigh with an other electric control. The chain counter will measure the length of the chain lowered in any case.

Lowering the anchor

To lower the anchor press key ▼ (DOWN). Hold the key pressed until the anchor reaches the desired position and then release it.

While moving down, the chain counter displays a window similar to the one shown below:



It is also possible to lower the anchor with an other electric control. The chain counter will measure the length of the chain lowered in any case.

Automatic down function

This function can be used only if it was previously set and activated on the FUNCTIONS/AUTO DOWN menu (see chapter SETTING THE CHAIN COUNTER).

 **ATTENTION:** regular operation of the windlass has to be checked when moving down automatically

To lower the anchor automatically to the set depth, press keys ● (SELECT) and ▼ (DOWN) simultaneously for more then three seconds. Once the procedure has started, both keys can be released.

The chain counter will lower the anchor to the set depth.

While moving down automatically, the chain counter displays a window similar to the one shown below:

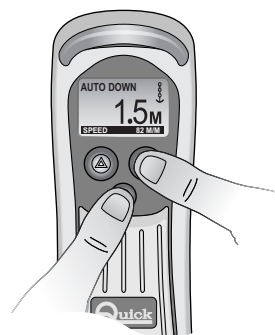

The automatic lowering procedure can be interrupted by pressing any key of the chain counter from which the procedure was activated, by activating the up function from an external device (from another chain counter or other control) or by shutting off the chain counter.



Free fall

At times the anchor may have to be lowered by wanting the windlass to free fall (without electrical command).

The chain counter will measure the length of the chain lowered under these circumstances as well. A window similar to the one shown below appears during free fall:

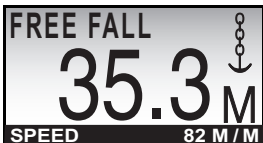

TURNING THE TORCH ON AND OFF

Press and release button ● (SELECT) in less than one second to turn on the torch. Press and release button ● (SELECT) in less than one second to shut off the torch.

When the instrument is turned on, the torch is always off, even if the instrument was shut off from the power supply with the torch turned on.

MONITORING

The information given on the monitoring line can be edited by pressing and releasing button ● (SELECT) within 1 to 3 seconds.

The following data can be displayed: date and time, supply voltage, chain speed and winch mode.



The date and time are stored even when the chain counter is shut off (it is equipped with a buffer battery).



The precision of the supply voltage reading is ± 1% accurate.

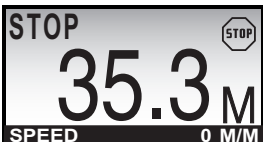

The precision of the chain speed reading is ±1% accurate.





WINCH MODE

This mode must be used when carrying out winch operations with the windlass. In this configuration the mechanism that moves the chain (gypsy) remains stationary while the drum can still turn.

To use the windlass for winch operations please consult relevant user manual.



ATTENTION: use this mode only if the windlass is configured for winch operations.



ATTENTION: in this mode the automatic down function is blocked, the up alarm function is deactivated and the count is not updated.

Once activated, the winch mode will open a window similar to this:



To select direction of drum rotation press the ▲ (UP) or ▼ (DOWN) button. Hold the button down until the operation is complete, then release the button.

While ▲ (UP) or ▼ (DOWN) button is pressed, the instrument will display a window like this:



If the instrument is turned off in winch mode, when turned on again it will display the last type of information selected (date and time, instrument power supply voltage or speed of chain movement).



SETTING THE CHAIN COUNTER

The chain counter has a several functions that can be personalized to satisfy user's requirements.

To go to the setting menu, press and release key ● (SELECT) (the monitoring line will start to flash after the button has been pressed) for more than 3 seconds.

As soon as the key is released a window similar to the one shown below is displayed:



Use keys ▲ and ▼ (UP and DOWN) to select the data items within the menu.

The data item that has been currently selected appears in reverse.

Use key ● (SELECT) to confirm the selected data item.

The following data items are provided on the settings menu, with the MASTER chain counter present on the network:

DATA ITEM	SYNTHETIC DESCRIPTION
COUNTER RESET	Measure of chain lowered reset.
FUNCTIONS	Automatic down and up alarm setting.
PERSONAL SET	Chain counter personalization: contrast, back-lighting, light delay, key beep
DATE AND TIME	System date and time setting
LANGUAGE	Language used for system messages Chain counter calibration:
CALIBRATION	unit of measurement, number of magnets installed, gypsy lap
AUTO CALIBRATE	Automatic chain counter calibration
UTILITY	Various chain counter controls
CAN CONFIG	MASTER/SLAVE setting if more than one chain counter is used
EXIT	Chain counter set-up menu exit



THE STRUCTURE OF THE MENUS

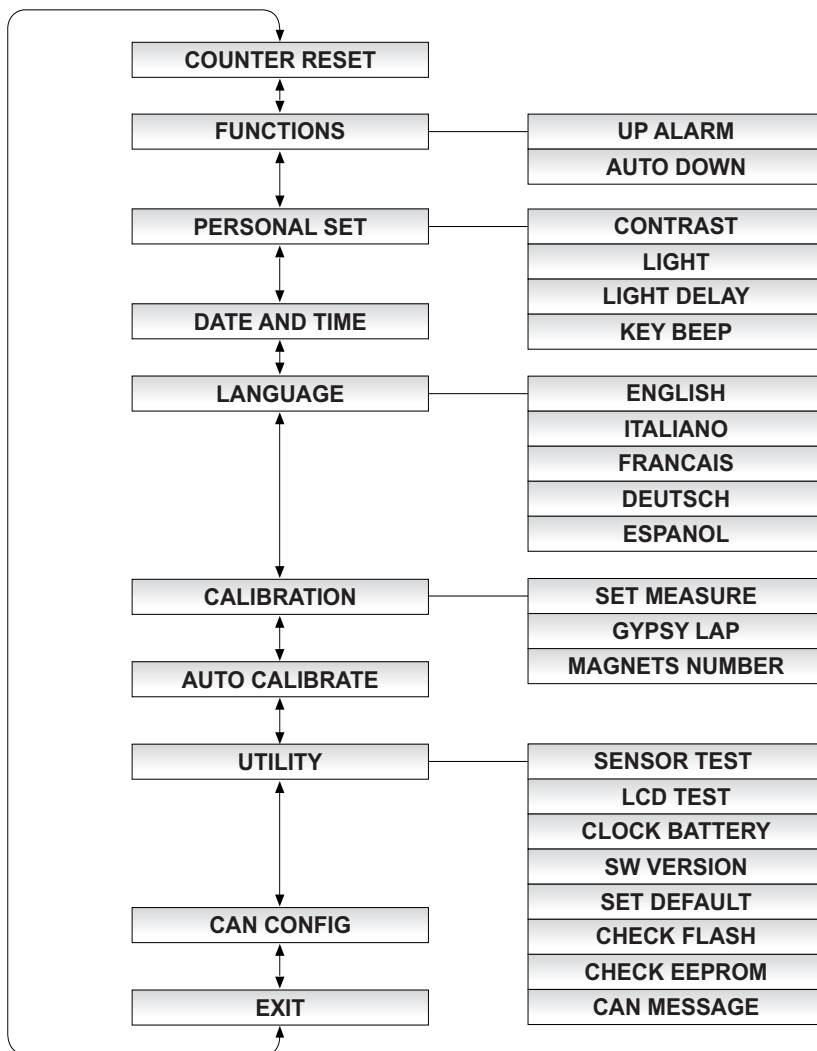



If a SLAVE chain counter is being used without the MASTER in the CAN network, the following “reduced” settings menu will be displayed:

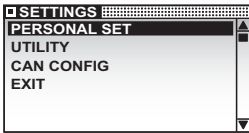

These submenus have particular parameters and functions for every single counter which can not be shared with other chain counters present on the CAN network.

SETTINGS MENU - COUNTER RESET

Use this option to reset the measure of chain lowered.

This option is to be used during installation or when the chain counter's reading does not match the actual length of the chain lowered. When this data item is selected, the following window is displayed:

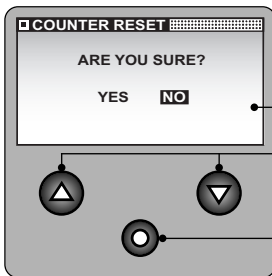

YES or NO can be selected.

Used to select the values available.

Confirm entry and go back to SETTINGS menu.

SETTINGS MENU - FUNCTIONS

Use this option to activate and set the up alarms and automatic down. The sub-menu of the FUNCTIONS option is shown below:

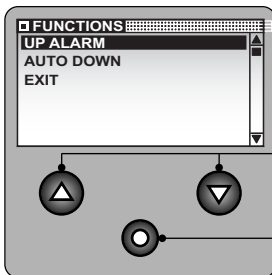

Used to select the data items in the sub-menu.

Press this key to go to the menu shown in REVERSE; if used to EXIT the system goes back to the SETTINGS menu.

SETTINGS MENU - FUNCTIONS - UP ALARM

Use this option to set or disable the up alarm. This function stops the anchor from moving up and informs the user when the length of the chain lowered is less than the set value.



ATTENTION: the up alarm function is active only by using a chain counter CHC 1102 M controls when the anchor moves up. It does not function if the anchor is moved up by any other remote control or a switch.



ATTENTION: the chain counter is not able to compensate for mechanical inertia of the windlass (the gypsy can rotate upward direction as soon as the command has been inactivated). Take this factor into consideration when setting the up alarm value.



ATTENTION: the alarm is displayed only once, if the chain measure lowered than the alarm threshold.



ATTENTION: even if the up alarm is enabled, the user must always pay careful attention and make sure the anchor is correctly pulled up.

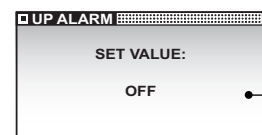

Examples of the windows used for the up alarm are shown below:

default: OFF

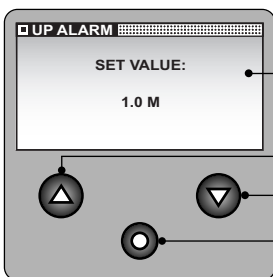

If the unit of measurement is set to METERS, the settable values are OFF, 1.0M, 1.5M, 2.0M, 2.5M, 3.0M, 3.5M, 4.0M, 4.5M, 5.0M.

If the unit of measurement is set to FEET, the settable values are OFF, 3.0F, 4.5F, 6.0F, 7.5F, 9.0F, 10.5F, 12.0F, 13.5F, 15F.

Increase

Decrease

Confirm value and go back to FUNCTIONS menu.

SETTINGS MENU - FUNCTIONS - AUTOMATIC DOWN

The automatic down function is enabled or disabled with this option. This function allows the anchor to automatically move down to the set depth (see chapter CHAIN COUNTER OPERATION paragraph AUTOMATIC DOWN FUNCTION).



ATTENTION: the chain counter is not able to compensate for mechanical inertia of the windlass (the gypsy can rotate downward direction as soon as the command has been inactivated). Take this factor into consideration when setting the automatic down value.



ATTENTION: even if the automatic down function is enabled, the user must always pay careful attention and make sure the anchor is correctly lowered.

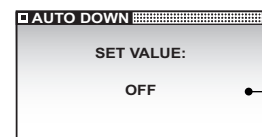

Examples of the windows used for the automatic down function are shown below:

default: OFF

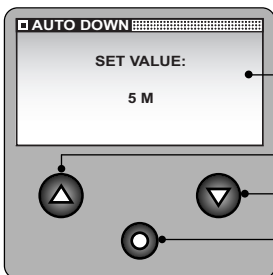

If the unit of measurement is set to METERS, the settable values are OFF, from 5M to 100M with 5M steps.

If the unit of measurement is set to FEET, the settable values are OFF, from 15T to 300F with 15F steps.

Increase

Decrease

Confirm value and go back to FUNCTIONS menu.



SETTINGS MENU

PERSONAL SET

This option allows the user to enable and set several functions to personalize the chain counter.

The PERSONAL SET sub-menu is shown below.

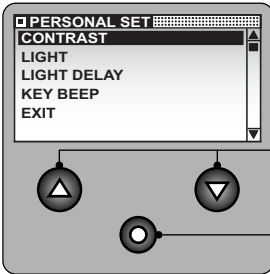

Selects the data items in the sub-menu.

Press this key to go to the menu shown in REVERSE; if EXIT has been selected the system goes back to the SETTINGS menu.

SETTINGS MENU - PERSONAL SET

CONTRAST

Use this option to adjust the contrast of the LCD. The change is immediately made without having to confirm the value.

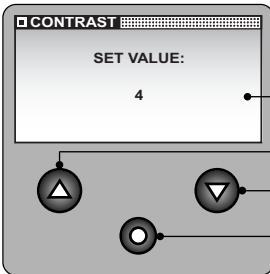

Selectable values: 1, 2, 3, 4, 5, 6, 7, 8. (default: 4).

Increase

Decrease

Confirm value and go back to PERSONAL SET menu.

SETTINGS MENU - PERSONAL SET

LIGHT

Use this option to adjust the back-lighting of the display screen. The brightness is immediately changed without having to confirm the value.

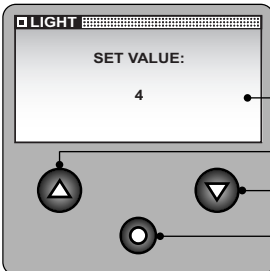

Selectable values: OFF, 1, 2, 3, 4, 5, 6, 7, 8. (default: 4).

Increase

Decrease

Confirm value and go back to PERSONAL SET menu.



SETTINGS MENU - PERSONAL SET

LIGHT DELAY

Use this option to set the delay time for shutting off the back-lighting of the display screen. The delay time starts to elaps as soon as the last key is released (or when FREE FALL is completed).

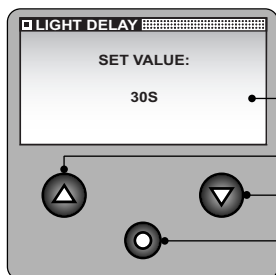

Selectable values: 30S, 60S, 90S, 120S, 180S, 240S, ON (always on). (default: 30S).

Increase

Decrease

Confirm value and go back to PERSONAL SET menu.

SETTINGS MENU - PERSONAL SET

KEY BEEP

Use this option to activate or deactivate the beep that sounds whenever a key is pressed.

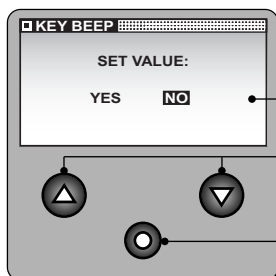

Selectable options: YES and NO. (default: YES).

Select the values available.

Confirm value and go back to PERSONAL SET menu.

SETTINGS MENU

DATE AND TIME

Use this option to set the clock and calendar.

The DATE AND TIME window appears as follows:

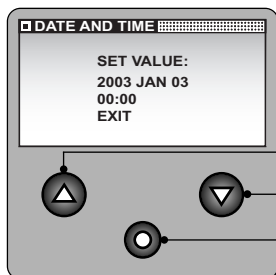

Increase

Decrease

Confirm value and go to next parameter; if EXIT has been selected the system goes back to SETTINGS menu.



SETTINGS MENU

LANGUAGE

Use this option to select the language in which the system messages are displayed.

The LANGUAGE sub-menu appears as shown below.



Select the data items.

Confirm value and go back to SETTINGS menu.

SETTINGS MENU

CALIBRATION

Use this option to calibrate the chain counter according to the windlass it is mounted on.

The CALIBRATION sub-menu appears as follows:

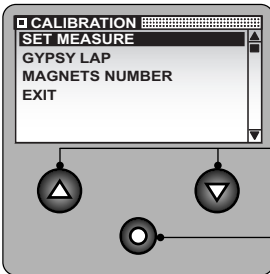

Select the data items in the menu.

Confirm value and go to next parameter; if EXIT has been selected the system goes back to SETTINGS menu.

SETTINGS MENU - CALIBRATION

SET MEASURE

Use this option to select the unit of measurement relative to measurement of chain lowered.

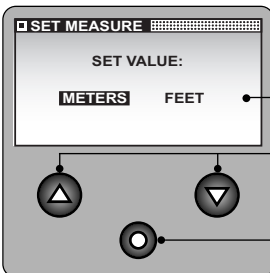

Selectable options: METERS or FEET. (default: METERS).

Select the values available.

Confirm value and go back to CALIBRATION menu.



SETTING THE CHAIN COUNTER

GB

SETTINGS MENU - CALIBRATION - GYPSY LAP

Use this option to set the measurement of the chain in one gypsy lap. To obtain this value, remove the gypsy, wind the chain around it and then measure its length.

Consult the User's manual of the windlass for more detailed instructions on how to remove and re-install the gypsy.

It is extremely important that the value set for GYPSY LAP is precise as it affects the accuracy with which the length of the lowered chain is measured

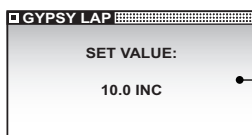

If the unit of measurement is set to FEET, the settable values are from 1.0 to 999.0 inc (default: 10 inc).

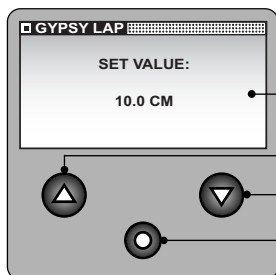

If the unit of measurement is set to METERS, the settable values are from 1.0 to 999.9 cm (default: 10 cm).

Increase

Decrease

Confirm value and go back to CALIBRATION menu.

SETTINGS MENU - CALIBRATION - NUMBER OF MAGNETS

Use this option to set the number of magnets installed on the gypsy.

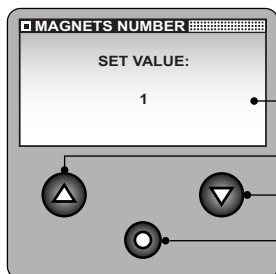

Selectable Values: 1 to 16. (default: 1).

Increase

Decrease

Confirm value and go back to CALIBRATION menu.



SETTINGS MENU - AUTOMATIC CALIBRATION

Use this option to automatically calibrate the chain counter. The first window regarding AUTOMATIC CALIBRATION is shown below:

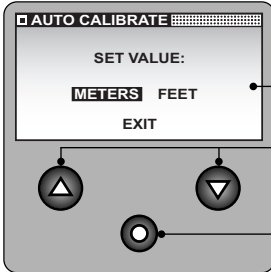

Use this option to select the unit of measurement used to measure the chain lowered. Selectable values: METERS or FEET.

Select the values available.

Confirm value and go to next window for AUTOMATIC CALIBRATION procedure, if EXIT is selected the system goes back to menu SETTINGS.

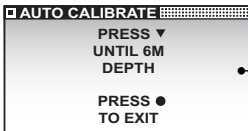

This window tells the user the chain has to be lowered 6 meters (or 20 feet, depending on the unit of measurement selected) in an uninterrupted manner. The length of the chain unwound each lap can be calculated according to the number of laps completed by the gypsy (counted by the chain counter).

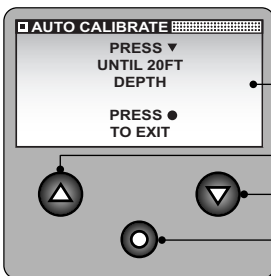

Not active

Chain down; it counts the number of gypsy laps.

Cancel procedure and go back to SETTINGS menu.

Once key ▼ (DOWN) is released the chain counter will stop the chain from moving down and automatically set the following values:

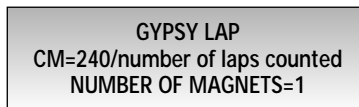
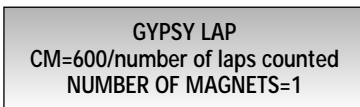

After which the following window will be displayed for two seconds:

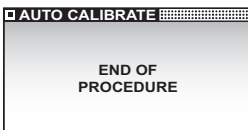

And the SETTINGS menu will be shown again.

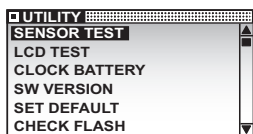

SETTINGS MENU

UTILITY

This option allows the user to perform procedures to check and control the chain counter operation.

The UTILITY sub-menu appears as shown below:

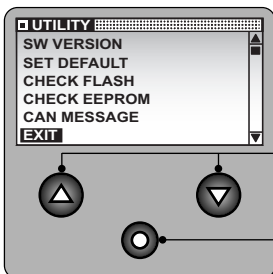

Select data items from sub-menu

Press this key to go to the menu shown in REVERSE; if EXIT has been selected the system goes back to the SETTINGS menu.

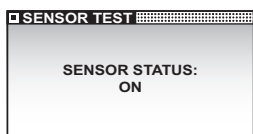

SETTINGS MENU - UTILITY

SENSOR TEST

This function can be used during installation or to check that the lap sensor works properly. If the sensor detects the magnet, ON is displayed and the buzzer sounds; otherwise OFF is displayed and the buzzer does not sound.

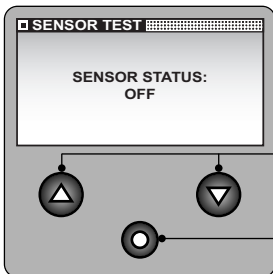

Go back to UTILITY

SETTINGS MENU - UTILITY - LCD TEST

This function can be used to check correct operation of the LCD display's pixels.

Once the data item has been confirmed from the utility menu, all the display pixels will be activated for 5 seconds; after which the system will go back to menu UTILITY.

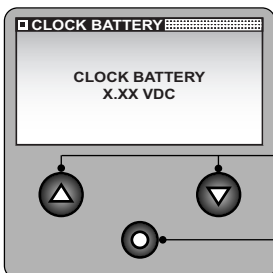

SETTINGS MENU - UTILITY

CLOCK BATTERY

This function displays the voltage of the clock's buffer battery.

Go back to UTILITY menu.



SETTINGS MENU - UTILITY

SW VERSION

This function displays the software version installed in the chain counter.

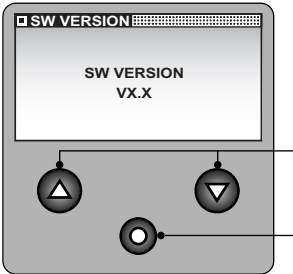

Go back to UTILITY menu.

SETTINGS MENU - UTILITY

SET DEFAULT

This function allows the user to enter the default values and restart the chain counter.

The SET DEFAULT window appears as shown below:

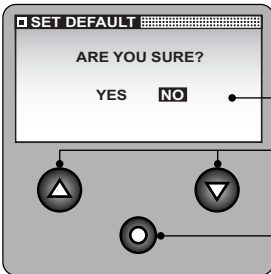

YES or NO can be entered.

Select data items from sub-menu.

Confirm value.

SETTINGS MENU - UTILITY

CHECK FLASH (PROGRAM MEMORY)

This function shows the calculated FLASH memory checksum (SUM) and the one stored during production (TRUE).

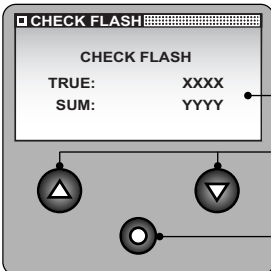

In order for the chain counter to operate properly the two values must match.

Go back to UTILITY menu.



SETTINGS MENU - UTILITY CONTROL EEPROM (DATA MEMORY)

This function shows the calculated EEPROM memory checksum (SUM) and the one stored (TRUE).

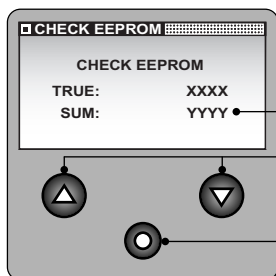

In order for the chain counter to operate properly the two values must match.

Go back to UTILITY menu.

SETTINGS MENU - UTILITY CAN MESSAGE

This function shows some information regarding CAN messages transmission state.

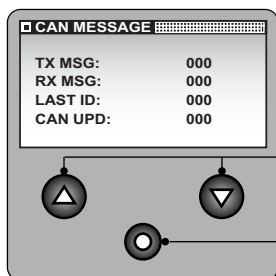

Go back to UTILITY menu.

SETTINGS MENU CAN CONFIGURATION

This option allows the user to determine chain counter's priority in the CAN network (see chapter MULTIPLE CHAIN COUNTERS).

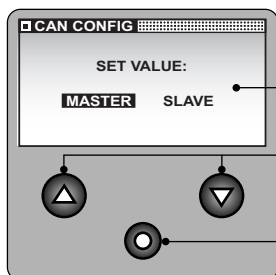

MASTER and SLAVE can be entered (default: MASTER).

Select the values available.

Confirm entry and go back to SETTINGS menu.



SYSTEM ERRORS

System errors may arise when the chain counter chain counter is turned on.

Checksum error

The following windows are displayed if the counter detects an error in the memorized data:

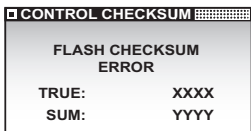

FLASH memory checksum error

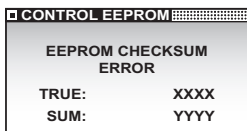

EEPROM memory checksum error

If one of these messages appears do not use the chain counter and contact a service center or QUICK® customer service without delay.

Multi Master error

If the chain counter detects more then one of MASTER chain counters in the CAN network, the following window is displayed:

Select chain counter's priority in the CAN network (see chapter MULTIPLE CHAIN COUNTERS).



SYSTEM FAULTS

System faults that appear on the state line divided into three categories which are shown below: problems with automatic reset, problems with automatic reset and keys locked and problems with manual reset.

PROBLEMS WITH AUTOMATIC RESET

These faults are automatically reset as soon as the cause that had generated the problem disappears.

Low voltage

This fault is displayed if the voltage drops below 10.5Vdc for more than one second. Reset takes place if the voltage is higher than 11.0Vdc for more than one second. Check the charge level of the batteries that supply voltage or the electrical system.

The window shown below appears when this problem is present:

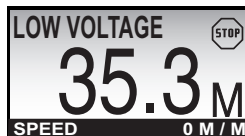

Clock battery low

This fault is displayed if the voltage of the clock battery drops below 2.80Vdc. The chain counter checks the battery voltage when turned on and every half hour. The problem is reset if the voltage is higher than or equal to 2.80Vdc. The clock battery can be replaced only at an authorized service center.

The window shown below appears when this problem is present:

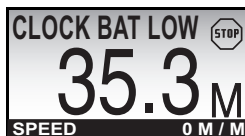



No MASTER

This fault is displayed if there is not a chain counter with MASTER priority in the CAN network (see chapter MULTIPLE CHAIN COUNTERS). See if the MASTER chain counter is on and the data line connections.

The window shown below appears when this problem is present:



CAN BUS communication error

This fault is displayed if there are errors that cannot be recovered during CAN network communication.

Make sure the data cables are properly connected.

The window shown below appears when this problem is present:



PROBLEMS WITH AUTOMATIC RESET AND KEYS LOCKED

These faults are automatically reset as soon as the cause that had generated the problem disappears. Some keys are disabled when these faults are present.

Opposed commands

This fault is displayed if keys UP or DOWN are pressed at the same time as the respective external control DOWN or UP key (other chain counters or other remot switch).

If the fault is present keys ▲, ▼ (UP, DOWN) are disabled.

The window shown below appears when this problem is present:

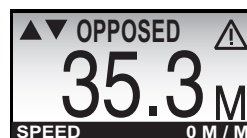

Overload

This fault is signaled when the instrument detects at short circuit or overload at the instrument's output.

Check wiring of signals UP and DOWN and absorption of the points of use connected to the instrument's output.

If a fault is present, keys ▲, ▼ (UP, DOWN) are inoperative.

A window similar to the one shown below appears if a fault is present:

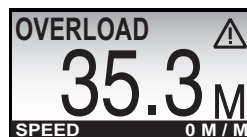

Remote programming active

This fault is displayed if a chain counter has entered the SETTINGS menu in the CAN network (see chapter MULTIPLE CHAIN COUNTERS). Wait until the chain counter has exit the menu.

If the fault is present key ● (SELECT) is disabled

The window shown below appears when this problem is present:

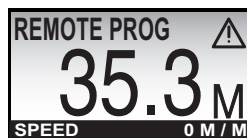



PROBLEMS WITH MANUAL RESET

These problems are reset by the user: by pressing key ● (SELECT) or turn off the chain counter and turn it back on. If the fault is present keys ▲, ▼ (UP, DOWN) are disabled.

Up alarm

This fault is displayed if the length of the chain is less than the value set on the FUNCTIONS\UP ALARM menu.

The window shown below appears when this problem is present:

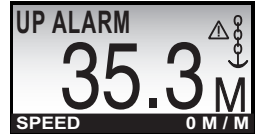

No sensor

This fault is displayed if the laps sensor does not detect the gypsy movement within four seconds when key ▲ or ▼ (UP or DOWN) of the chain counter or other switches are pressed.

Check the distance between the magnet and sensor, operation of the laps sensor and the wiring/connections.

The window shown below appears when this problem is present:

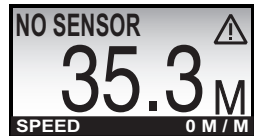

Sensor failure

This fault is displayed if the chain counter detects a short circuit in the sensor for more than four seconds when key ▲ or ▼ (UP or DOWN) of the chain counter or other switches are pressed.

Check operation of the laps sensor and the wiring/connections.

The window shown below appears when this problem is present:

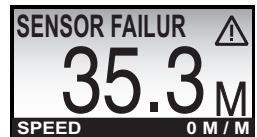

CONFIRMATION MESSAGES

Confirmation messages that may appear on the state line are shown below.

Stop

When no commands are sent to the windlass, the following window is displayed:

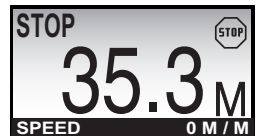

Memory stored

As soon as four seconds elapsed from the last operation was completed (up, down, automatic down, free fall), the chain counter stores the length of the lowered chain in the EEPROM memory.

The window shown below is displayed while the data are being saved:





MAINTENANCE

The chain counter does not require any particular maintenance. To assure top performance, check the cables and electrical connections once a year.

Clean the chain counter with a soft rag dampened in water. Do not use chemicals or harsh products to clean the chain counter.

TECHNICAL DATA

MODEL	CHC 1102 M
-------	------------

OUTPUT CHARACTERISTICS

UP/DOWN contacts current	5A max - 2A in continuous
--------------------------	---------------------------

INPUT CHARACTERISTICS

Supply voltage ⁽¹⁾	from 9 to 30 Vdc
Current absorbed when idling ⁽²⁾	30 mA
Maximum current absorbed ⁽³⁾	235 mA + current used by solenoid/reversing solenoid unit

AMBIENT CHARACTERISTICS

Operating temperature ⁽⁴⁾	-20 ÷ +70 °C
Degree of protection ⁽⁵⁾	IP 67

CASE

Dimensions (WxHxD)	62.2 x 185 x 49.4 mm
Weight	850 g

GENERAL

Communication interface	CAN BUS with differential transceiver
Clock battery	CR2032 (3Vdc)
EMC class	EN 55022/B

⁽¹⁾ The chain counter can reset itself if the voltage is less than 9 Vdc.

⁽²⁾ Typical value with back-lighting off and windlass not on.

⁽³⁾ Typical value with back-lighting on at highest level and windlass on.

⁽⁴⁾ With temperatures below 0°C the crystals in the LCD slow down.

⁽⁵⁾ Except for the area where the electric contacts are connected (IP 00).

CHC 1102 M - DIMENSIONS (mm)

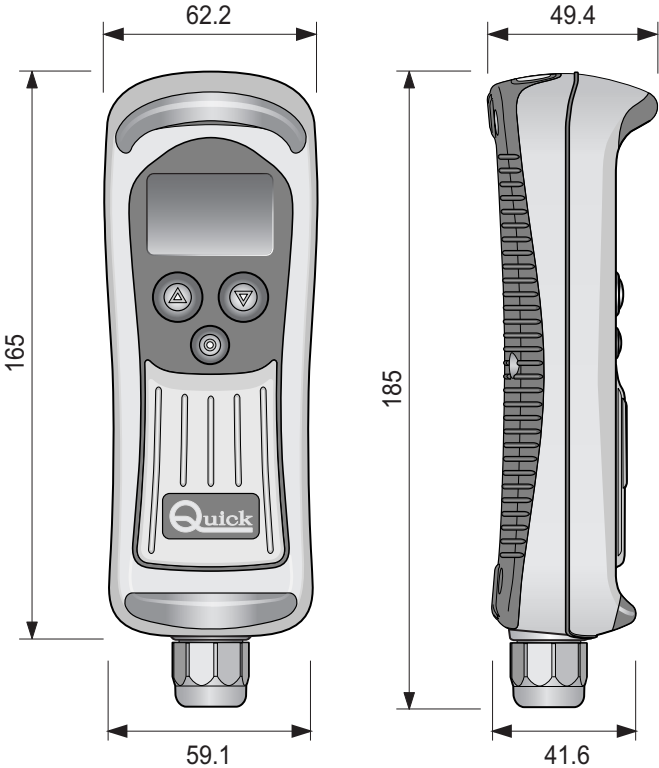

THE WIRING DIAGRAM

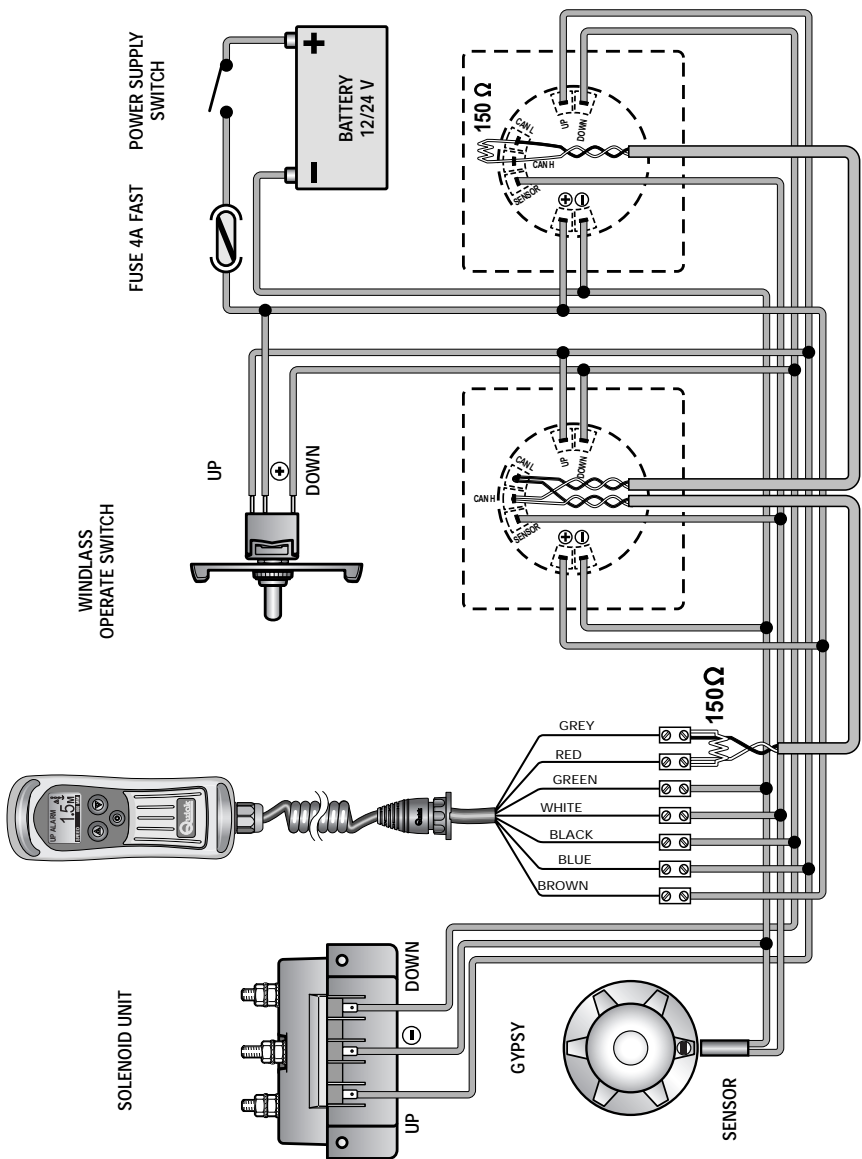

Quick[®]

QUICK[®] SRL - VIA PIANGIPANE , 120/A - 48020 PIANGIPANE (RAVENNA) - ITALY
TEL. +39.0544.415061 - FAX +39.0544.415047

WWW.QUICKITALY.COM - E-MAIL: QUICK@QUICKITALY.COM