



ArcelorMittal

# Steel for enamelling and enamelled steel

## User manual





# User manual

## Steel for enamelling and enamelled steel

1	Introduction	5
2	Enamel	7
3	Enamelling of steel	13
4	Enamelling processes and associated steel grades	21
5	Forming of steel for enamelling	31
6	Joining of steel for enamelling	37
7	Properties of enamelled steel	43
8	Enamelled steel and the environment	47
9	Uses of enamelled steel	49
10	Appendices	55





## 1 Introduction

Enamelled steel is a material with exceptional properties and has many applications in various aspects of everyday life.

In the home, enamelled steel is used in the kitchen for worktops and casings for domestic appliances. This has the advantage of making them resistant to any sort of everyday damage, so that both hot dishes and frozen food can safely be placed on them, for instance; it also means that they can be cleaned with a quick wipe of a sponge. The same material is used for cookware, again offering an array of advantages: enamelled saucepans prevent the growth of bacteria, do not absorb odours, are not attacked by food acids and can be used directly on the gas hob. In the bathroom, we find bathtubs in all shapes and colours, in a matt, shiny or satin finish, and impervious to the ravages of water and time. Last but not least, enamelled water-heater tanks prevent any water leaks.

Enamelled steel also has important applications in industry, even in the most corrosive atmospheres, e.g. in the chemical and agro-food industries. Its resistance to chemicals and to fermentation makes it an excellent lining for silos, chemical reactors, dryers, closed tanks and other water-treatment plant storage systems. Furthermore, because of its resistance to high temperatures and heat reflection properties, it can be used in columns and heat exchangers. Its resistance to corrosion caused by combustion gases also makes it an excellent material for the manufacture of flue linings and exhaust manifolds.

Finally, the use of enamelled steel is a first-rate solution in the construction industry for cladding buildings or for interior decoration, as it successfully combines a rigid steel substrate with an enamel coating. The result is an end product that is aesthetically pleasing, durable and easy to clean, making it a material that will appeal to even the most demanding clients. Enamelled steel can also be an appropriate option for lining tunnels, as it ensures they are easier and cheaper to clean and improves fire resistance.

### Definition

The fusion, at high temperature, of two materials as noble and as different as steel and enamel has given rise to a material with quite remarkable properties and offering many applications: enamelled steel.

The origins of the use of enamel are lost in the mists of time, but its qualities have always been highly prized. The remarkably well-preserved enamelled pottery and jewellery found on sites of ancient Egyptian and Persian civilisations testify to the astonishing durability of this material.

Today, enamelling steel has become a high-tech process using highly sophisticated materials and state-of-the-art techniques. Enamelled steel is a material that meets modern-day requirements of longevity, aesthetic qualities, hygiene and respect for the environment.

The enamelling process entails applying one or more layers of enamel to the pre-prepared surface of an appropriate grade of steel and then firing it at a temperature of between 780 °C and 850 °C. This requires the involvement of three parties:

- A steel manufacturer
- An enamel manufacturer
- An enameller, who can be either a manufacturer or a subcontractor

### A brief history of enamel

The earliest examples of jewellery and gold and silverware that make use of the technique of cloisonné enamel on metal (gold, silver, copper, bronze) come from Cyprus and date back to the Mycenaean period, most likely around the 13<sup>th</sup> century BC. The technique then spread to Egypt and Greece around the 6<sup>th</sup> century BC.

The Celts developed the champlevé enamel method in the 3<sup>rd</sup> century BC. The golden age of enamelling was between the 6<sup>th</sup> and the 11<sup>th</sup> century, during the Byzantine period. The Byzantine style heavily influenced the whole of western production throughout the 12<sup>th</sup> century, when enamel began to be developed in Limoges.

The first utensils in enamelled cast iron date back to the 18<sup>th</sup> century and appeared in Germany. The industrial revolution in the 19<sup>th</sup> century made it possible to manufacture cast iron (advances in blast furnaces) and then steel (development of converters) in large quantities, which opened the way for the development of enamelling on these substrates.

Finally, present-day enamelling processes have developed over the course of the 20<sup>th</sup> century, mirroring progress in steel production, but also keeping pace with ever-stricter environmental regulations.

### The characteristics of enamelled steel

Enamelled steel has many properties that make it a first-rate material for numerous applications. Its characteristics result from combining the properties of its two constituent elements: steel and enamel. Steel contributes mechanical strength and formability, while enamel provides durability and a beautiful glossy appearance.

Here are just a few examples of its many properties:

- Corrosion resistance
- Chemical resistance
- Mechanical strength of the enamelled surface
- Resistance to heat and cold
- Thermal shock resistance
- Fire resistance
- Hygiene and ease of cleaning
- Multiplicity and stability of colour

These characteristics will be discussed in more detail below (see chapter 7: Properties of enamelled steel).



## 2 Enamel

2.1	The composition of enamel	8
2.2	The manufacture of enamel	8
2.2.1	The various stages in manufacturing enamel	8
2.2.2	Preparation of enamel	9
2.3	The different types of enamel	11
2.3.1	Enamel and substrate	11
2.3.2	The different types of enamel for steel	11

## 2.1 The composition of enamel

Enamel is a glass obtained by fusion at high temperature between 1000°C and 1300°C. Its main constituent is **silica**,  $\text{SiO}_2$ , which is the most abundant mineral in the earth's crust. Free silica exists principally in its crystallised form, **quartz**, which has a purity in excess of 99%. It is also found in combined form in feldspars, clays and micas. In order to confer on enamelled parts its properties of durability, silica glass has to be modified, as it cannot be used in its original state. Its melting point is too high, its coefficient of thermal expansion is too low compared to that of steel and its adhesion to steel is zero. Various constituents therefore have to be added in order to obtain an enamel. These can be categorised in four main groups, according to the properties they impart to the enamel:

**Refractories**, which give enamel an amorphous structure, and hence mechanical strength. These include, for example, **alumina** ( $\text{Al}_2\text{O}_3$ ), which serves to lower the coefficient of expansion, increase resistance to temperature, chemicals and abrasion and facilitate the action of opacifiers, another constituent of enamel.

**Fluxes**, which lower the melting point and firing temperature and increase the coefficient of expansion. These are mainly composed of **borax** (sodium tetraborate in its anhydrous form ( $\text{Na}_2\text{B}_4\text{O}_7$ ) or hydrated form ( $\text{Na}_2\text{B}_4\text{O}_7 \cdot 10 \text{H}_2\text{O}$ )) and alkaline oxides such as **oxides of sodium** ( $\text{Na}_2\text{O}$ ), **potassium** ( $\text{K}_2\text{O}$ ), **lithium** ( $\text{Li}_2\text{O}$ ), **calcium** ( $\text{CaO}$ ), **magnesium** ( $\text{MgO}$ ) and **strontium** ( $\text{SrO}$ ). These constituents produce borosilicates of sodium, potassium, lithium, calcium, magnesium or strontium, which have a lower melting point than silica (approximately 1400°C instead of 1720°C). The melting point may also be lowered by adding **fluorine** ( $\text{F}_2$ ) or **boron trioxide** ( $\text{B}_2\text{O}_3$ ). Fluxes, such as the alkaline oxides, increase the coefficient of expansion by filling the "voids" in the silica structure.

**Adhesion agents**, which are **metal oxides** that are involved in chemical redox reactions to promote adhesion between the steel surface and the enamel coating. These reactions will also involve the iron and carbon in steel, as well as atmospheric oxygen. Adhesion agents are present in ground-coat enamel, mainly in the form of **nickel oxide** ( $\text{NiO}$ ), **molybdenum oxide** ( $\text{MoO}$ ), **cobalt oxide** ( $\text{CoO}$ ), **cupric oxide** ( $\text{CuO}$ ), **manganese oxide** ( $\text{MnO}_2$ ) and **chromic oxide** ( $\text{Cr}_2\text{O}_3$ ).

**Opacifiers and colouring agents**, which contribute visual and tactile qualities to enamelled parts. Opacifiers serve to increase the opacity of enamel and are present in cover-coat enamel. The most common are **titanium dioxide** ( $\text{TiO}_2$ ), **antimony oxide** ( $\text{Sb}_2\text{O}_5$ ), **zirconium oxide** ( $\text{ZrO}_2$ ) and **tin oxide** ( $\text{SnO}$ ). Colouring agents are obtained by combining mineral oxides. The colour of enamel depends on the type of colouring agent, its concentration in the enamel, the chemical composition of the enamel and the firing conditions in the enamelling furnace.

The most common procedure is for the colouring agent, in the form of fine particles, to be mechanically mixed with the enamel during the grinding stage, before application to the substrate.

## 2.2 The manufacture of enamel

### 2.2.1 The various stages in manufacturing enamel

The first step is to check, weigh and mix the various constituents of enamel (up to 15). This is followed by the fusion stage.

The purpose of the fusion process is to render the final amorphous structure of the enamel uniform and to lower the firing temperature. This requires the "glass" to be melted at a temperature of between 1100°C and 1300°C, depending on the desired composition of the enamel. The most common process involves using a tunnel furnace (gas or electric), where the mixture is introduced at one end and comes out the other. Movement through the furnace is by gravity. The mixture remains in the furnace about an hour. When it emerges it is cooled rapidly, first of all by being passed through a water-cooled rolling mill to form a glass sheet, then into a cooler. Crushing completes the cooling cycle. This rapid quenching process, from a high temperature, fixes the structure of the glass and prevents any phase separation.

An alternative fusion process involves using a rotary furnace into which the constituents are poured, mixed and heated; liquid enamel is then poured into a pit and water quenched. After cooling and crushing, enamel frit is obtained.



## Fusion of enamel

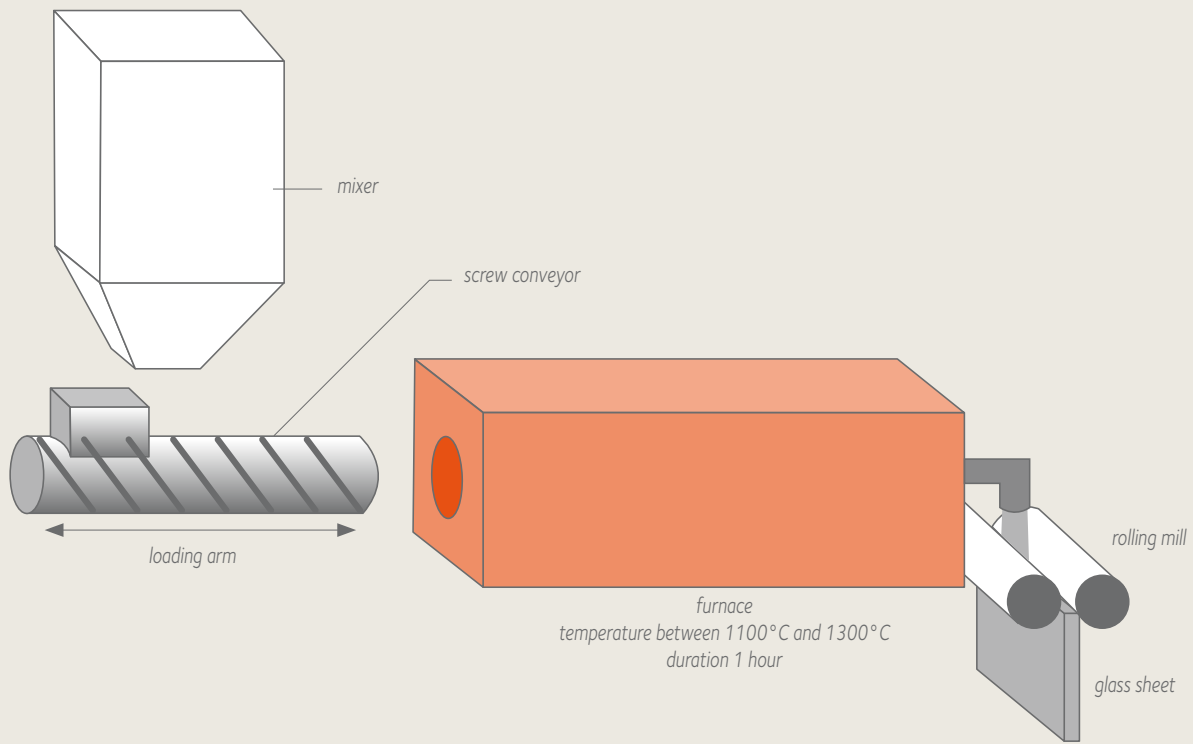

### 2.2.2 Preparation of enamel

Enamel frit cannot be used as such. It must first be mixed with other constituents, then ground. These steps may be carried out either by the enamel manufacturer or by the enameller to whom the manufacturer has supplied the necessary materials.

Enamel may be applied **in liquid form**. In this case, after the addition of certain ingredients (suspension, refractory, colouring agents, electrolytes and opacifiers), the frit is ground and mixed with water to form a slurry, which will be used for dip coating or spraying applications. Enamellers, in particular manufacturers of domestic appliances who do long production runs in a single colour, became increasingly reluctant to prepare the enamel themselves. This led to the introduction of “ready-to-use” powder in the 1980s to simplify the preparation of the slurry. The powder is prepared by the enamel manufacturer by adding specific products before grinding. The enameller has only to add colouring agents (optional) before mixing the powder with water to obtain the slurry.

Enamel may also be applied **in the form of powder**, obtained by grinding the frit. The grinding time is determined experimentally. The ground powder then has to be sieved, to be rid of lumps and various residues, then passed through a magnetic separator (permanent magnet or electromagnet) to eliminate any iron particles in the powder. These particles tend to create “holes” in the enamel, which reduces the steel’s corrosion protection. Finally, the grains of enamel are coated with silicon, enabling them to adhere to the substrate between the application and firing stages. The enamel powder obtained does not require any additives or further treatment at the enameller and can be directly used in powder spray guns. It takes a great deal of investment to set up a powder unit, as it has to be electrostatic to be financially viable. However, this process is more economical in the long term.

Preparation of the enamel

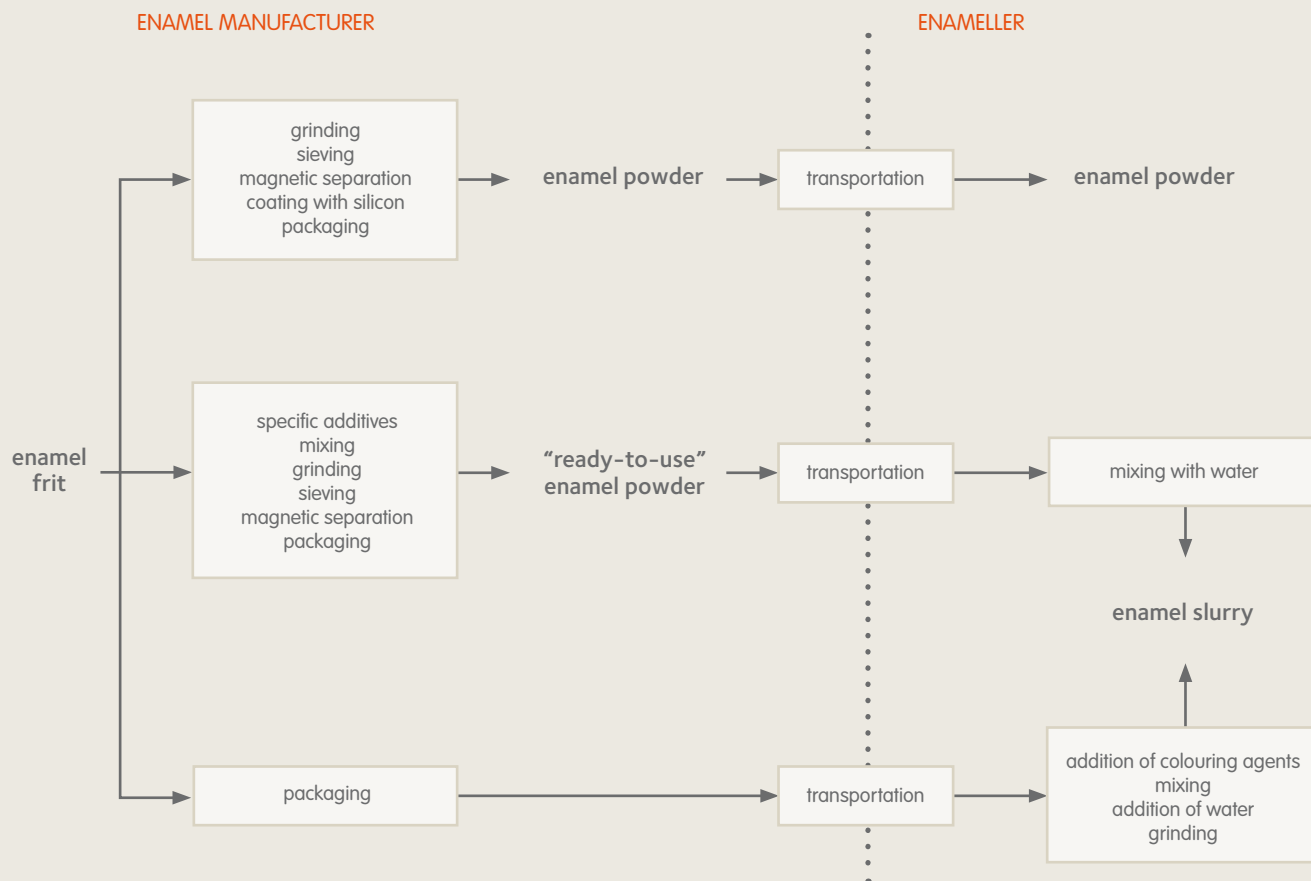

## 2.3 The different types of enamel

Enamels have different compositions depending on the type of substrate to be coated and, in the case of steel, depending on the enamelling process used.

### 2.3.1 Enamel and substrate

The composition of enamels is varied in order to match the enamel firing temperature to the substrate. The higher the firing temperature, the better the quality of the enamelled parts. As far as the metal is concerned, however, the firing temperature is limited by the substrate. For example, phase changes in steel must be taken into account. Moreover, the coefficient of expansion of enamel must be compatible with that of the substrate.

### 2.3.2 The different types of enamel for steel

#### Ground-coat enamel

Ground-coat enamel contains metal oxides (Ni, Co, Cu oxides), which promote enamel to steel adhesion by creating alloys with the iron in steel (see 7.1 on the subject of the adhesion of enamel to steel). Since metal oxides are dark in colour, white ground coat does not exist.

More reactive ground-coat enamels exist, containing a higher proportion of metal oxides, which avoids the need to pickle the steel before enamelling. These enamels are used, for instance, for the two-coat/one-fire enamelling process.

Ground-coat enamel also protects against corrosion of the enamelled part. Furthermore, depending on the type of part to be enamelled, other constituents will be added to obtain:

- Acid-resistant properties (oven cavities, dripping pans) by addition of  $\text{TiO}_2$
- Alkali-resistant properties (sanitary ware, washing machines) by addition of  $\text{ZrO}_2$
- Improved corrosion resistance for water-heater applications by addition of  $\text{ZrO}_2$  and  $\text{Al}_2\text{O}_3$

#### Self-cleaning enamels

Self-cleaning enamels are used in domestic ovens and help eliminate the fat produced when food is cooked. There are two types of self-cleaning enamels: catalytic and pyrolytic. We therefore talk about catalytic and pyrolytic self-cleaning ovens.

- **Catalytic** cleaning takes place while the oven is working normally, at about  $200^\circ\text{C}$ . Enamel contains oxides that catalyse the breakdown of fat, forming water and carbon dioxide. Moreover, this type of enamel is very refractory, hence porous, which has the effect of increasing the contact surface between the enamel and the fat, thus facilitating its elimination:



Efficiency falls off over time as a result of progressive blockage of the pores.

- **Pyrolytic** cleaning takes place while the oven is empty, at about  $520^\circ\text{C}$ . Fat and residues that are deposited on the walls during cooking are burnt at this temperature, leaving only a carbon deposit that can be wiped off:

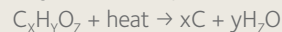

This type of enamel has a softening point higher than the pyrolytic temperature. It is glossy, non-porous and highly resistant to acids and alkalis.

#### Cover-coat enamels

Cover-coat enamels give enamelled parts their aesthetic quality and also help to increase their chemical resistance.

Since they contain absolutely no adhesion agent, they cannot be used alone on a metal substrate under any circumstances.

#### Enamels for low-temperature firing

These enamels for use on aluminised substrates have been developed from enamels used for aluminium by modifying the coefficient of expansion.

Their firing temperature ( $560^\circ\text{C}$ ) is lower than that of enamels used on bare steel substrates.





## 3 Enamelling of steel

3.1	<b>The enamelling process</b>	<b>14</b>
3.2	<b>Surface treatment before enamelling</b>	<b>15</b>
3.2.1	Shot blasting	15
3.2.2	Degreasing	15
3.2.3	Rinsing	16
3.2.4	Pickling	16
3.2.5	Acid rinsing	17
3.2.6	Nickel deposition	17
3.2.7	Final rinse, neutralisation and drying	18
3.3	<b>Enamel application</b>	<b>18</b>
3.3.1	Wet application	18
3.3.2	Dry application: electrostatic powder spraying	19
3.4	<b>Drying and firing of enamel</b>	<b>19</b>
3.4.1	Drying of enamel	19
3.4.2	Firing of enamel	19
3.4.3	Enamel to steel adhesion mechanisms	20

## 3 Enamelling of steel

### 3.1 The enamelling process

The enamelling process entails applying and firing one or more layers of enamel on one or both sides of a suitable steel substrate.

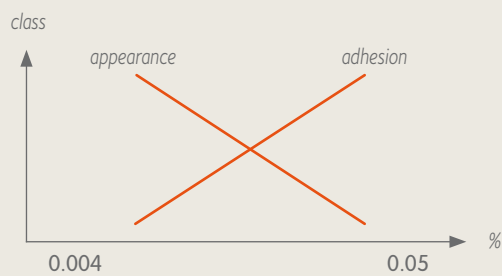
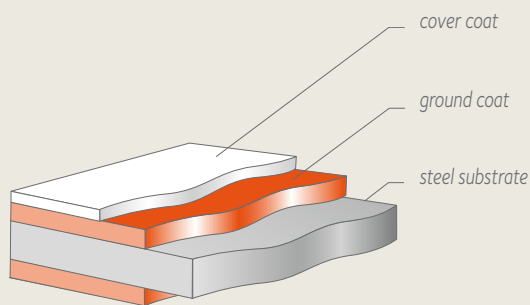

Successful enamelling is characterised by:

- **Good adhesion of enamel** to steel
- **Good surface appearance** after firing of enamel

The carbon content of the steel can hinder the process of achieving these two properties. Carbon is important to ensure the adhesion of enamel. However, if its content is too high this can adversely affect the surface appearance of enamel due to the release of gaseous CO and CO<sub>2</sub>, produced during firing. This antinomy explains the variety of enamelling processes that exist.

The enamelling process generally comprises several steps:

- Preparation of the surface of the part after forming
- Preparation of the enamel
- Application of the enamel to the steel
- Drying
- Firing at high temperature

There is a choice of several enamelling processes, depending on the type of part and final appearance required:

- Enamelling on hot rolled substrate
- Conventional enamelling (two coats/two firings)
- Ground-coat enamelling (one coat/one firing)
- Direct-on white enamelling
- Two-coat/one-fire enamelling
- Enamelling on metallic coated substrate

### 3.2 Surface treatment before enamelling

The purpose of surface treatment is to obtain a surface that is compatible with the enamelling process. Surface treatment comprises various steps. The number of steps varies according to the enamelling process used:

- Shot blasting *used for enamelling on hot rolled substrate*
  - Degreasing
  - Rinsing
  - Pickling
  - Acid rinsing
  - Nickel deposition
  - Rinsing
  - Neutralisation
  - Drying
- mandatory for direct-on white enamelling*

#### 3.2.1 Shot blasting

Surface treatment by **shot blasting** of **hot rolled** substrates is used, for example, to make the bottoms and bodies of water heaters, or to make gas cooker burner caps. The purpose of this treatment is to **increase the surface roughness** of the steel. This provides a better keying of the enamel, as during the enamel firing cycle, enamel-metal chemical reactions are promoted by the resulting greater contact surface area, thereby increasing enamel to steel adhesion. Together with the chemical hydrogen traps created during steel production, this improves resistance to the defect known as “fish scale”.

Shot blasting is carried out on an **unoiled** substrate so as to avoid contaminating the shot. If the shot does become contaminated with oil, it is less effective and soils the surface of the steel. This soiling may cause the enamel to be rejected where a wet application process is to be used.

#### 3.2.2 Degreasing

The purpose of degreasing is to remove exogenous matter present on the steel surface and originating from earlier steps: rust preventing oils, drawing oils and various kinds of dust. Degreasing is therefore a very important step in the process of surface preparation.

Various parameters must be checked:

- The **type** of degreasing agent
- The degreasing **temperature**, which must be between 60°C and 90°C, depending on the process used
- The **concentration** of degreasing agent (45–50 g/l)
- The **pH** of the degreasing baths
- The treatment **time** (15 minutes’ immersion – a few minutes’ spraying)
- Possible **mechanical action** (agitation of the bath or spraying pressure)

**Alkaline** degreasing is the most common process used. Alkaline solutions can have three different physico-chemical actions:

- Saponification: fatty substances are dissolved in the presence of an aqueous solution of soda or potash, forming soluble soaps
- Emulsification: fats are dispersed in fine droplets by phosphates or silicates
- Decrease in surface tension: fat molecules are coated with organic agents, which weakens the bonds between them and the substrate

Two methods are employed: **immersion** (or dipping) and **spraying**. The mechanical action (agitation of the bath, spraying pressure) increases the effectiveness of degreasing. In the case of degreasing by immersion, several baths are arranged in series.

Inadequate degreasing causes surface blemishes, demonstrating the importance of monitoring the conditions under which this procedure is performed. Another thing to watch out for is the phenomenon of resinification of the oil on the part to be degreased, which when exposed to light makes degreasing very difficult, even impossible. Lastly, surface blemishes in the metal (scratches, pores etc) may trap oil residues that may form gases during the enamel firing cycle.





### 3.2.5 Acid rinsing

In the case of direct-on white enamelling, we shall see later that nickel must be deposited on the part after pickling to ensure good adhesion of the white enamel to the steel.

The **quantity of nickel** that can be deposited on a part at a given temperature, the nickel deposition time and the nickel concentration in the bath vary according to pH. The maximum quantity is achieved at a **pH of 2.8**. However, it has been found that after the pickling process, the pH at the surface of the part is less than 1. If rinsing is not carried out after pickling, the pH will remain too low and insufficient nickel will be deposited. If the part is rinsed in water the result will be the same.

The purpose of **acid rinsing** is therefore to **increase the pH** of the part, without exceeding the optimum value.

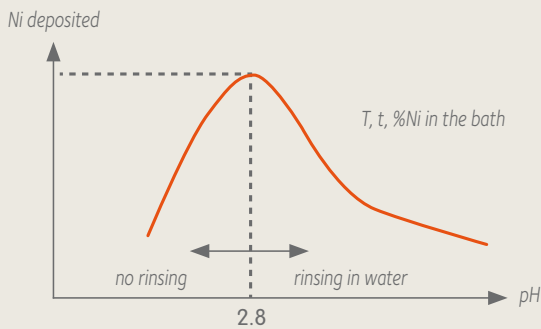

### 3.2.6 Nickel deposition

Nickel plays an important part in the direct-on white enamelling process in promoting enamel **adhesion**. If necessary, it may be used in small quantities in conventional processes (nickel flash).

The most common method used to deposit nickel is the precipitation of metallic nickel by displacement of iron ions:  
 $2\text{Fe} + \text{NiSO}_4 + \text{H}_2\text{SO}_4 \rightarrow 2\text{FeSO}_4 + \text{Ni}^{\downarrow} + \text{H}_2^{\uparrow}$

Conditions:

- NiSO<sub>4</sub>: 12-15 g/l
- pH: 2.8
- temperature: 70 °C
- time: 7 minutes

As in the case of pickling, the nickel deposition conditions have a significant influence on the quantity of nickel deposited. A slight variation may have serious consequences on enamel adhesion.

To ensure that the direct-on white enamelling process produces enamel with good adhesion and an attractive appearance, an optimum combination exists between the iron loss to be obtained and the quantity of nickel deposited:

- iron loss: **25-50 g/m<sup>2</sup> per side**
- nickel coating: **1-2 g/m<sup>2</sup> per side**

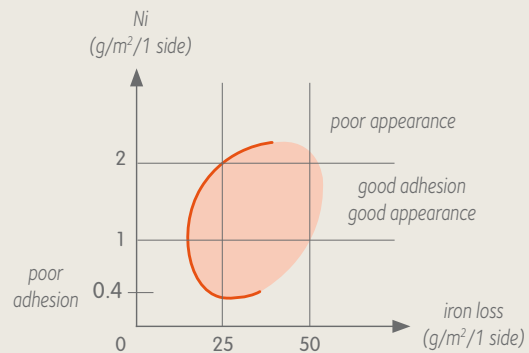

## 3.2.7 Final rinse, neutralisation and drying

The purpose of the final rinse is to eliminate all traces of acid still present on the surface of the part. Two baths are generally used:

- First bath:  
2.5 < pH < 3.2 and T = 30-35 °C for 7 minutes
- Second bath:  
3.5 < pH < 4 and T = 25 °C for 7 minutes

The purpose of neutralisation is to completely eliminate any acid residues:

- 10.5 < pH < 11.5 and T = 70 °C for 7 minutes

Once surface preparation is complete, the parts must be dried to prevent them rusting before enamelling.

## 3.3 Enamel application

Enamel may be applied using either the wet or dry process.

### 3.3.1 Wet application

There are several ways of applying enamel by means of the wet process.

#### Dip coating

The parts to be coated are plunged into an enamel slurry (mixture of enamel powder and water), the density and viscosity of which are closely monitored. The parts are then suspended to allow the excess enamel applied to drip off, thus ensuring a uniform coating thickness. This process is often used for parts with a complex shape, such as oven cavities. One drawback of this process is that sagging of the enamel can occur. A variation of dip coating, the "dip and shake" method, which involves moving the parts about different axes when they emerge from the bath, minimises sagging and excessive thickness of the enamel coating.

#### Flow coating

This process entails spraying the entire surface of the part with enamel through one or more round nozzles.

#### Air-assisted spraying

Enamel is sprayed on the parts to be coated using a spray gun powered by a jet of compressed air at a pressure of between 3 and 4.5 bar. The process is generally carried out in a booth, the parts being hung on a metal conveyor belt. Manual spraying requires highly experienced operators in order to avoid sagging and excessive thickness of the enamel coating. This procedure may be automated and tends to be reserved for short production runs.

#### Electrostatic spraying

A charge differential is applied between the negatively charged enamel and the positively charged parts to be coated. The enamelling spray gun consists of a central tube through which the enamel passes, surrounded by an annular nozzle through which the atomising air passes faster than the stream of enamel. This difference in speed causes the enamel slurry to atomise into fine droplets. At the tip of the spray gun, the droplets pass through an atmosphere that has been ionised in an electric field and become negatively charged before being deposited on the part to be enamelled. Once the initial coats have been applied, the droplets will be less and less attracted to the part and a repulsive force will arise. This opposes the attractive force until equilibrium is reached, thus controlling the thickness of the coating. The resulting enamel coating is uniform and losses are minimised.

### The ETE process (Elektro-Tauch-Emaillierung, electrostatic dip enamelling, or electrophoresis)

The electrophoresis process is principally used for direct-on white enamelling. Particles of enamel, in colloidal suspension in a saline solution, are conveyed under the effect of an electric field. They become negatively charged on the surface and are carried to the anode of the electrolytic cell, which is the part to be enamelled. This process results in a very uniform thickness of enamel (automatic limitation of deposition) and an exceptional surface appearance. It is a very efficient technique for flat parts, but does have a few drawbacks:

- It is expensive
- It requires the use of a cathode having the shape of the part to be enamelled
- Monitoring the electrical properties of the enamel slurry is complex

#### 3.3.2 Dry application: electrostatic powder spraying

The principle of electrostatic powder spraying is the same as for the wet method. An electric field is formed between the nozzle electrode and the part to be enamelled. The particles of enamel, propelled out of the spray gun by a stream of air, become negatively charged, migrate towards the part to be enamelled (positive electrode) and are deposited there. Once the first coat has been deposited, the particles start losing their attractive force. A repulsive force is then generated. When this becomes equal to the attractive force, the particles are no longer deposited. This process therefore provides a uniform enamel coating and automatically limits its thickness.

The particles of enamel must be coated (organic envelope, generally silicon) in order to prevent hydration, which would have the effect of reducing their electric resistance, thereby preventing correct deposition of enamel on the part. The quality of the organic coating, the grain size and rheology of the powder are key factors for obtaining uniform deposition of enamel and an attractive surface appearance after firing.

This process is highly effective for flat parts, but it is more difficult to enamel hollow parts – e.g. oven cavities – because of the Faraday cage effect.

It offers many advantages:

- Waste reduction
- Material savings
- Uniformity of coating thickness

## 3.4 Drying and firing of enamel

### 3.4.1 Drying of enamel

Drying is a vital step after the wet application of enamel. Moisture, which represents 40–50% of the mass deposited, can in fact cause localised withdrawal of the enamel during firing. The dry coating obtained is called “**biscuit**”.

Air drying is not recommended, as the parts may become contaminated by dust particles in the air and residual moisture may remain in the enamel, favouring the formation of “fish scale” defects. Dryers or ovens must be used at a temperature of between 70°C and 120°C. Infrared radiation or convection drying is the safest way of preparing parts for firing.

### 3.4.2 Firing of enamel

With the exception of the process of enamelling on aluminised sheets, firing is generally carried out at a temperature of between 780°C and 850°C, which is well above the softening temperature of enamel (500–600°C). It can be done in a box furnace or in a tunnel furnace (continuous). Firing time and temperature depend on the thickness of the steel and the type of enamel. Firing is carried out in an oxidising atmosphere.

Box furnaces are generally used for short production runs and small parts. They are particularly popular with independent enamellers.

Tunnel furnaces are either rectilinear, U-shaped or L-shaped and are suitable for long production runs. They are divided into three sections: pre-heating, firing and cooling, which permits a controlled increase and decrease in temperature. The parts, arranged on cradles, pass through these sections, suspended from a conveyor. Air seals, located at the entrance and exit of the furnace, prevent heat loss.

The furnaces are mainly electric or gas-fired radiant tube. The heating elements are arranged on the walls and bottom of the furnace. Thermal energy is transmitted to the parts by radiation and convection.

## 3.4.3 Enamel to steel adhesion mechanisms

The adhesion of enamel to uncoated steel is achieved by means of chemical reactions that take place during the firing and cooling cycles.

The process can be divided into four stages:

### 1<sup>st</sup> stage: up to 550°C

- The **moisture** (H<sub>2</sub>O) and the **oxygen** (O<sub>2</sub>) in the air **penetrate** the **porous enamel** and oxidise the iron in the steel.
- This causes the formation of a layer of **iron oxide** at the enamel/steel interface.
- The **atomic hydrogen** arising from the decomposition of H<sub>2</sub>O **diffuses** into the **steel**, recombines as **molecular hydrogen** and **fills the holes** in the steel. **The solubility of H<sub>2</sub> in steel increases with temperature.**

### 2<sup>nd</sup> stage: 550-830°C

- The **enamel softens** then **fuses**, forming a semi-permeable layer. This **reduces gaseous exchanges** with the furnace atmosphere.
- The **iron oxide** present at the enamel/steel interface is **dissolved by the enamel.**

### 3<sup>rd</sup> stage: around 830°C

- At this temperature **chemical redox reactions** take place between the **iron oxide** layer at the enamel/steel interface, the **metal oxides** in the enamel and the **carbon** in the steel.
- **Fe-Ni-Co alloys** precipitate at the enamel/steel interface. These are at the **heart** of the **adhesion** of enamel to steel.
- **Adhesion** is **promoted** by the **roughness** of the steel.
- The **dissolved oxygen recombines** with the **carbon** in the steel, **releasing gaseous CO/CO<sub>2</sub>**. The intensity of these releases must be monitored.
- The **quantity of hydrogen** in the steel is at **maximum** levels.

### 4<sup>th</sup> stage: cooling

- The **enamel solidifies**, **stopping gaseous exchanges**.
- **Hydrogen solubility** in the steel **decreases** when the **temperature falls**. The steel becomes **oversaturated** and hydrogen **accumulates under the enamel coating**. An **excessive quantity of hydrogen** at the interface causes **“fish scale”** defects (see chapter 4.1).

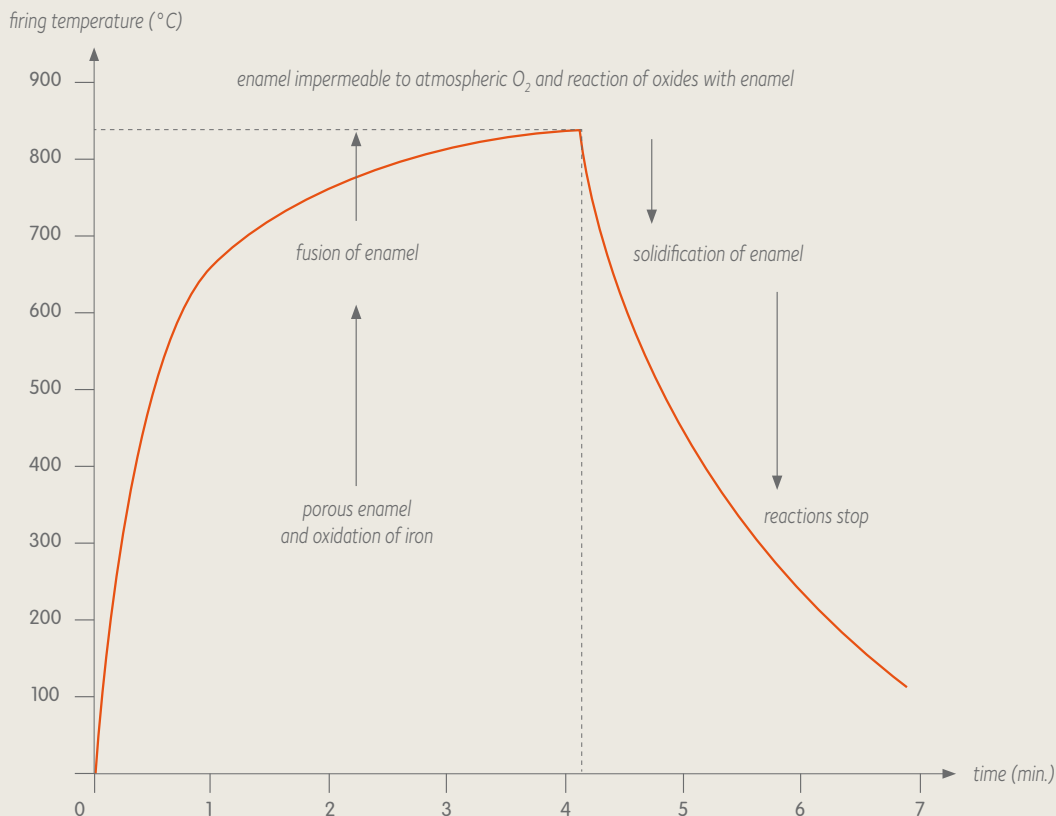



## 4 Enamelling processes and associated steel grades

4.1	<b>Hydrogen and "fish scales"</b>	<b>22</b>
4.1.1	Formation of "fish scale" defects	22
4.1.2	Impact on the metallurgical properties of steel for enamelling	22
4.1.3	Measuring steel's absorption capacity: the Strohleim hydrogen permeation test	23
4.2	<b>Enamelling on hot rolled steel</b>	<b>24</b>
4.2.1	Scope of application	24
4.2.2	The ArcelorMittal range of hot rolled steel for enamelling	24
4.2.3	Use	25
4.2.4	Easyfilm® HPE and Easyfilm® HFE	25
4.3	<b>Enamelling on cold rolled steel</b>	<b>25</b>
4.3.1	Ground-coat enamelling: one coat/one firing	25
4.3.2	Conventional enamelling: two coats/two firings	25
4.3.3	Direct-on white enamelling	26
4.3.4	Two-coat/one-fire enamelling	26
4.3.5	The ArcelorMittal range of cold rolled steels for enamelling	26
4.3.6	Block diagram of enamelling processes on cold rolled substrates	28
4.4	<b>Low-temperature enamelling on aluminised steel substrates</b>	<b>28</b>
4.4.1	Aluminised steels for enamelling: Alusi® BEC and Alusi® BEA	28
4.4.2	Application	29
4.4.3	Use	29

Present-day enamelling processes have developed over the course of the 20<sup>th</sup> century, mirroring progress in steel production, but also keeping pace with ever-stricter environmental regulations. Conventional enamelling on cold rolled steel was thus followed in the 1960s by direct-on white enamelling thanks to the emergence of open coil decarburised steel (patented by the Bethlehem Steel Corporation in 1958), then by the development of the two-coat/one-fire enamelling process in the 1980s, and finally the introduction of enamelling techniques on metallic coated substrates at the turn of this century. Enamelling on hot rolled substrates also developed in parallel to the above processes, particularly for water-heater applications.

The enumeration of enamelling processes and associated steel grades follows this historical trend. However, before we outline these processes, we must first mention the main parameter that will govern the metallurgy behind them: resistance to “fish scale” defects.

## 4.1 Hydrogen and “fish scales”

### 4.1.1 Formation of “fish scale” defects

As we have observed already, hydrogen penetrates the steel during the enamel firing cycle in the following manner:

- The moisture (H<sub>2</sub>O) in the air in the furnace atmosphere penetrates the enamel and migrates towards the enamel/steel interface.
- The H<sub>2</sub>O then breaks down.
- The oxygen is used in bonding reactions between the enamel and steel.
- Atomic hydrogen diffuses into the steel and then recombines in the form of hydrogen gas (H<sub>2</sub>).

**During this phase of rising temperatures, hydrogen solubility in the steel increases.**

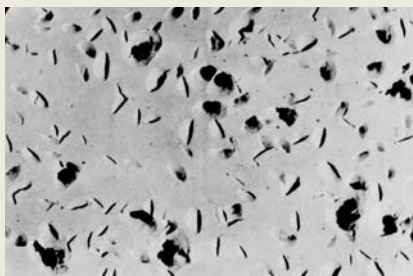

“Fish scale” defects

**During the cooling cycle, hydrogen solubility in the steel decreases:**

- The enamel solidifies.
- Some of the excess hydrogen has to escape from the steel (since its solubility decreases).
- The hydrogen migrates towards the enamel/steel interface and remains trapped; it is no longer able to escape since the enamel has solidified.
- Oversaturation with hydrogen therefore creates very high local pressure spots. Enamel blisters are formed, resulting in the defect known as “fish scale” (it resembles fish scales, hence its name). The intensity of the phenomenon will be directly linked to the amount of water vapour in the system. The steel’s capacity to absorb hydrogen is also of crucial importance.

This defect is dreaded by both enamellers and end users, as it only appears after a varying delay.

The main parameters that tend to aggravate the formation of “fish scale” defects are as follows:

- A **moist firing atmosphere**
- **Inadequate drying** if the enamel is applied by the wet process
- Use of **steel that is not suitable** for enamelling

Enamelling conditions thus have to be strictly monitored in order to counter this defect. The steel must also have an adequate hydrogen absorption capacity, which requires manufacturing it with specific metallurgical properties.

### 4.1.2 Impact on the metallurgical properties of steel for enamelling

#### Cold rolled steel

The production of enamelling steels must favour the eventual formation of sufficient hydrogen traps. In the case of aluminium-killed steel, cementite clusters tend to form (iron carbide, Fe<sub>3</sub>C) during the hot rolling process at high coiling temperatures. As iron carbides are very brittle, their fragmentation during cold rolling will cause small voids to appear in their trail: these voids are called hydrogen traps.

Similarly, manganese sulphide precipitates reduce “fish scale” defects. During cold rolling, these are deformed, causing a loss of cohesion with the matrix and the appearance of small voids.

Other solutions that make use of hydrogen’s affinity with elements such as boron may also be adopted.

### Aluminium-killed steel

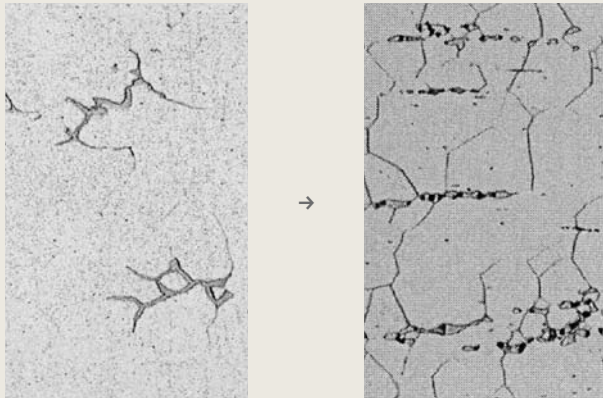

Hot rolling:  $Fe_3C$  cementite

Fragmented cementite after cold rolling

In the case of interstitial free steel (IFS), titanium precipitates formed before hot-strip coiling will act as traps. This chemical trapping is consolidated by loss of cohesion between the matrix and the titanium precipitates during the cold rolling process.

### Hot rolled steel

In the case of hot rolled steel, chemical hydrogen trapping is the only possibility and titanium carbides are the most effective traps.

However, trapping is less effective in this instance than with the cold rolling process.

#### 4.1.3 Measuring steel's absorption capacity: the Strohlein hydrogen permeation test

The Strohlein permeation test is used to measure steel's hydrogen absorption capacity by determining the total volume of cavities present in the steel. It makes use of hydrogen gas produced by electrolysis. The solution consists of sulphuric acid plus small quantities of arsenic oxide and mercury chloride. This is maintained at 25 °C. When a direct current is applied to the solution by a current generator, the  $H^+$  protons in the solution trigger a reduction reaction.

Atomic hydrogen penetrates into and then diffuses through the metal, recombining in molecular form in imperfections within the metal. When the metal is saturated, the output signal changes. A permeation curve is thus obtained, showing the quantity of hydrogen passing into the metal as a function of time.

The permeation time ( $t_0$ ) is directly linked to the steel's enamelling capacity. EN 10209 defines the TH value above which steel is said to be suitable for enamelling as 100.

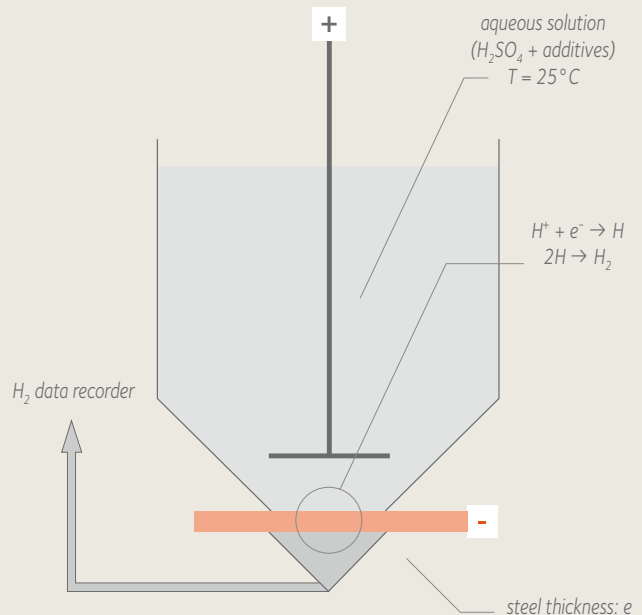
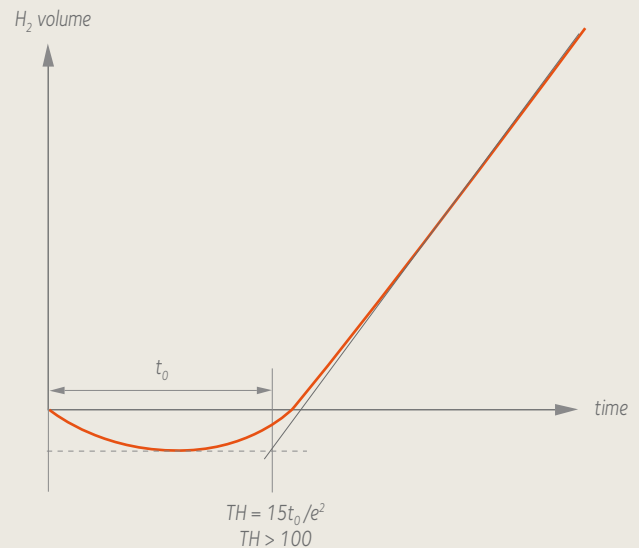

This test can only be used on steel with cavities, i.e. aluminium-killed steel. In the case of IFS, susceptibility to "fish scale" defects is measured by means of an enamelling test in a moist atmosphere or by using a low-adhesive ground-coat enamel (sensitive ground coat).

# 4 Enamelling processes and associated steel grades

## 4.2 Enamelling on hot rolled steel

### 4.2.1 Scope of application

Enamelling on a hot rolled substrate entails applying one or more layers of enamel on one or both pre-prepared sides and then firing at a high temperature.

Hot rolled steel for **one-side enamelling**, this being steel with a specific chemical composition that can guarantee:

- Excellent resistance to “fish scale” defects in the enamelled parts
- Conservation of mechanical properties after forming and firing of the enamel.

Two grades are available to match the requirements of different applications: **S240EK** and **S300EK**. These can be supplied pickled, unpickled, oiled or unoled.

We should point out that no standards exist for this kind of steel.

### 4.2.2 The ArcelorMittal range of hot rolled steel for enamelling

		Grades	
		S240EK	S300EK
Forming	Bending – Profiling	☒	☒
	Bending / Hard profiling – Light drawing	☒	△
	Drawing	☒	●
Joining	Problem-free welding <sup>(1)</sup>		
Enamelling process			
One-side enamelling	Surface treatment	Possible degreasing + shot blasting <sup>(2)</sup>	
	Enamel application	By the wet or dry process <sup>(3)</sup>	
	Enamel firing	At approx. 830°C	
Applications	Water-heater bottoms	Water-heater bodies	

☒ Grade that can readily be used for the process (forming or enamelling)

△ Grade that can be used with caution (forming or enamelling)

● Grade that is not recommended or is prohibited (forming or enamelling)

(1) Grades that can be welded without any difficulty, whatever the welding process may be (TIG, MIG, seam welding, laser)

(2) The product is generally supplied pickled and unoled. Surface treatment may include degreasing followed by shot blasting. The non-enamelled side is coated with borax to prevent scale formation during firing.

(3) Enamel is usually applied by the wet process (flow coating or spraying). In this case, the enamel must be dried between 70°C and 120°C. Electrostatic powder application is another option.



#### 4.2.3 Use

Grades **S240EK** and **S300EK** are used to manufacture water-heater tanks. Their mechanical properties remain unchanged after forming and firing of the enamel. This has the following advantages:

- It extends the life span of water heaters by increasing their fatigue safety margin during heating phases.
- The thickness of the steel can be reduced, thereby reducing raw materials cost of the water heater.

Finally, after enamelling, the inside wall of the tank displays excellent corrosion, heat and moisture resistance.

#### 4.2.4 Easyfilm® HPE and Easyfilm® HFE

Easyfilm® HPE and Easyfilm® HFE are dry, non-permanent films applied to hot rolled substrates and have the following advantages:

- Corrosion protection: three months' protection in the case of Easyfilm® HPE, and six for Easyfilm® HFE
- They are dry products, which helps keep workshops clean and improves safety
- Suitability for welding and laser cutting
- Compatibility with all known lubricating oils
- All traces of grease can be removed by alkaline degreasing
- Complete absence of heavy metals

Easyfilm® HFE also has an excellent friction coefficient over its entire surface ( $\mu < 0.1$ ), making it particularly suitable for creating deeply drawn or profiled parts that generally require additional lubrication during processing. This has obvious economic benefits for the user:

- It simplifies the enamelling process
- It obviates the need to purchase lubricants for the deep drawing process
- It reduces cost of treating and recycling used oil

These products are compatible with all dry enamelling processes, subject to certain conditions.

### 4.3 Enamelling on cold rolled steel

#### 4.3.1 Ground-coat enamelling: one coat/one firing

This process entails applying and firing one ground coat of enamel on each side of the part to be enamelled and is intended for semi-visible and non-visible parts. Given that only one layer of ground coat containing naturally coloured adhesion oxides is applied, only dark colours are possible.

This process can be used for:

- **Oven and microwave oven cavities**
- **Internal components of built-in ovens or cookers:**  
inner doors, dripping pans, baking trays
- **Washing machine drums**

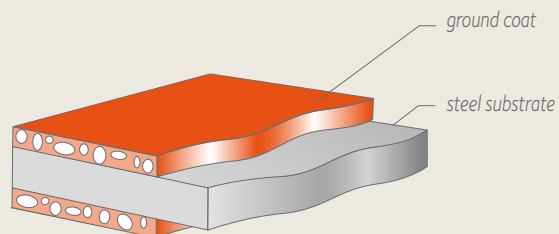

#### 4.3.2 Conventional enamelling: two coats/two firings

This process is used for visible parts. After performing ground-coat enamelling (one coat/one fire), this entails applying and firing an enamel cover coat on the visible side (and possibly on both sides). This is suitable for producing white or coloured parts with a very good surface appearance after enamelling:

- **Housing panels for domestic appliances:**  
hobs, covers and tops of cookers, doors for built-in ovens, microwave ovens and cookers
- **Bathtubs and shower trays**
- **Architectural panels**

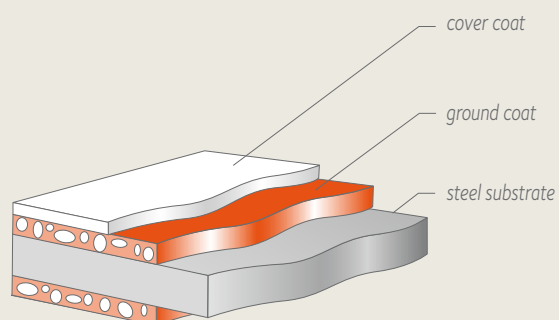

### 4.3.3 Direct-on white enamelling

When enamelling visible parts, conventional enamelling is a relatively expensive process due to the need to apply two coats of enamel and have two firing cycles. The aim of direct-on white enamelling is to achieve the same result, i.e. a white enamelled part without any visible surface defects, by applying a single coat of enamel and performing just one firing cycle. It is therefore necessary to use an enamel that does not contain any adhesion oxides (as otherwise it will not be white) and a steel with a very low carbon content in order to prevent the release of gases during firing.

To ensure that the enamel adheres to the steel, the part is pickled after degreasing in order to activate its surface, and a coating of nickel is then applied with the aim of improving adhesion between the enamel and the steel.

Pickling is usually performed using sulphuric acid. The intensity of pickling is measured by means of the iron loss value.

Optimum adhesion and surface appearance after enamelling are achieved with an iron loss of 25 g/m<sup>2</sup> per side and a nickel coating of between 1 and 2 g/m<sup>2</sup> per side.

The steel's low carbon content will be ensured by annealing open coil steel (open coil annealing, OCA), which entails first running braided stainless steel wire between the wraps of the coil so as to leave a few mm of space between the wraps, then annealing this coil in a batch annealing process in an oxidising atmosphere to decarburise the steel. The space between the wraps allows contact between the annealing gas (water vapour) and the entire surface of the steel, thus facilitating decarburisation.

Direct-on white enamelling has a number of advantages over the conventional enamelling process:

- A thinner enamel coating, but offering greater impact resistance.
- The very low carbon content of these steels makes it possible to obtain a very high quality surface appearance after enamelling (no bubbles or black spots) and also limits deformation at high temperatures (e.g. during pyrolysis cycles).

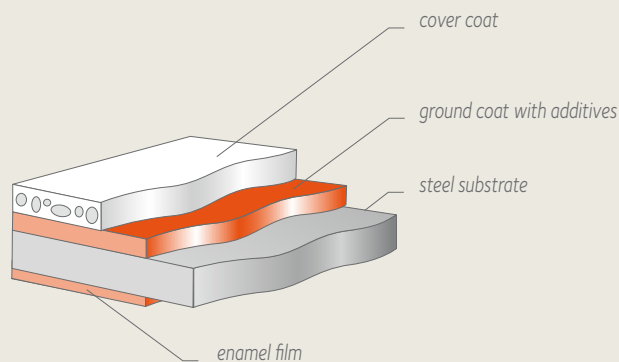
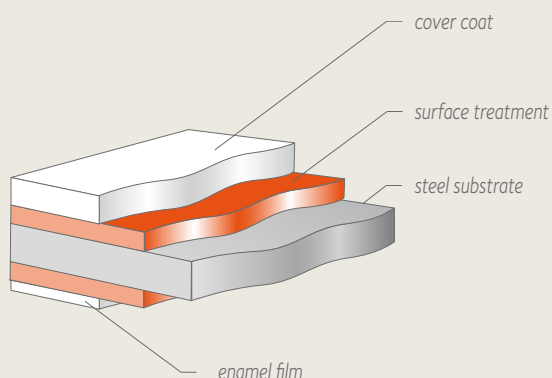

### 4.3.4 Two-coat/one-fire enamelling

Direct-on white enamelling has two major drawbacks:

- Surface preparation is complex, expensive and not very environmentally friendly
- Decarburised steel must be used

The aim of the two-coat/one-fire enamelling process is to obtain the same result (white parts with no surface blemishes) with a simpler surface preparation and just one firing cycle. Surface treatment is limited to degreasing only.

Enamel to steel adhesion is achieved by using ground-coat enamel with added adhesion oxides (nickel or cobalt oxide) in a layer no thicker than 40 µm.

Steel with a low carbon content must be used to prevent excessive release of gases during firing. A carbon content of C = 0.02 to 0.03% is usually recommended.

### 4.3.5 The ArcelorMittal range of cold rolled steels for enamelling

ArcelorMittal has a full range of cold rolled steels for enamelling (see the table on the next page).

Grades **DC01EK**, **DC04EK**, **DC05EK** and **DC06EK** are in compliance with EN 10209. Grade **DC05EK** was developed specially for the manufacture of bathtubs. Grade **DC07EK** is intended for very deep drawing applications.

**DC01EK**, **DC03EK**, **DC04EK** and **DC05EK** are aluminium-killed steels, whereas **DC06EK** and **DC07EK** are IFS-type steels decarburised in steel plants (IFS: interstitial free steel).

**DC04ES** is a cold rolled, aluminium-killed steel with a specific chemical composition, particularly with respect to its carbon content. This steel was developed specially for the two-coat/one-fire enamelling process after degreasing only.

**Solfer®** and **Solfer®+** are aluminium-killed, decarburised, open coil annealed steels that are intended for direct enamelling to give a white or coloured finish with a single coat following degreasing, strong pickling and nickel deposition. However, these types of steel can be used in two-coat/one-fire enamelling and ground-coat or conventional enamelling (for enamelling pyrolytic self-cleaning oven cavities) if ground-coat enamels are used that are suitable for the low intrinsic reactivity of these steels.

These grades correspond to standardised grades **DC03ED** and **DC04ED** (EN 10209).

Last but not least, they offer excellent resistance to “fish scale” defects. We can guarantee a minimum TH of 100 for grades **DC01EK, DC03EK, DC04EK, DC05EK, DC04ES, Solfer®** and **Solfer®+**, in accordance with EN 10209.

Grades		DC01EK	DC03EK	DC04EK	DC05EK	DC06EK	DC07EK	DC04ES	Solfer®	Solfer®+
<b>Forming</b>	Bending – Profiling	⊕			△			⊕		
	Bending / Hard profiling – Light drawing	⊖	△	⊕		△		⊕		
	Drawing	⊖		⊕						
	Deep drawing	⊖			△	⊕		⊖	△	
<b>Joining</b>		Problem-free welding <sup>(1)</sup>								
<b>Enamelling process</b>										
<b>Direct-on white enamelling</b>	Surface treatment								Degreasing, pickling and nickel deposition <sup>(2)</sup>	
	Enamel application								By wet or dry process <sup>(3)</sup>	
	Enamel firing								At approx. 830°C	
<b>Two-coat/one-fire enamelling</b>	Surface treatment	⊖			Degreasing <sup>(4)</sup>					
	Enamel application	⊖			By wet or dry process <sup>(5)</sup>					
	Enamel firing	⊖			At approx. 830°C					
<b>Conventional enamelling: ground-coat enamelling and two-coat/two-fire enamelling</b>	Surface treatment	Degreasing <sup>(6)</sup>								
	Enamel application	By wet or dry process <sup>(7)</sup>								
	Enamel firing	At approx. 830°C								

⊕ Grade that can readily be used for the process (forming or enamelling)

△ Grade that can be used with caution (forming or enamelling)

⊖ Grade that is not recommended or is prohibited (forming or enamelling)

(1) Grades that can be welded without any difficulty, whatever the welding process may be. Other joining processes (clinching, lock seaming) may also be used.

(2) Degreasing, pickling and nickel deposition. Iron loss of 25 g/m<sup>2</sup> per side. Nickel coating of between 1 and 2 g/m<sup>2</sup> per side.

(3) A 130 μ coat of enamel is applied using the wet or dry method: spraying, electrostatic dip enamelling (ETE) or electrostatic deposition.

(4) Meticulous degreasing must be performed.

(5) Enamel is applied using the wet or dry method: spraying or electrostatic deposition. Suitable ground-coat enamels with added adhesion oxides (nickel or cobalt oxide) must be used. The thickness of the ground coat should not exceed 30 μ, as otherwise the reactivity will be too high. The thickness of the cover coat should be 100 μ.

(6) Surface treatment is limited to degreasing only. If additive-free ground-coat enamel is used, light pickling is recommended (targeting an iron loss of 5 g/m<sup>2</sup> per side) after meticulous degreasing, especially for grades DC06EK and DC07EK, which have a lower surface reactivity. Surface reactivity can be improved by a nickel flash. Pickling can be avoided by using a ground-coat enamel with added adhesion oxides (nickel or cobalt oxide).

(7) Enamel can be applied by a wet or dry process: dip coating, spraying or electrostatic deposition. A ground coat with or without additives is applied to a thickness of about 100 μ on both sides. In the case of two-coat/two-fire enamelling, a cover coat is applied on the visible side to a thickness of about 130 μ. The enamel must be dried if applied using the wet method (at a temperature of between 70°C and 120°C).

## 4.3.6 Block diagram of enamelling processes on cold rolled substrates

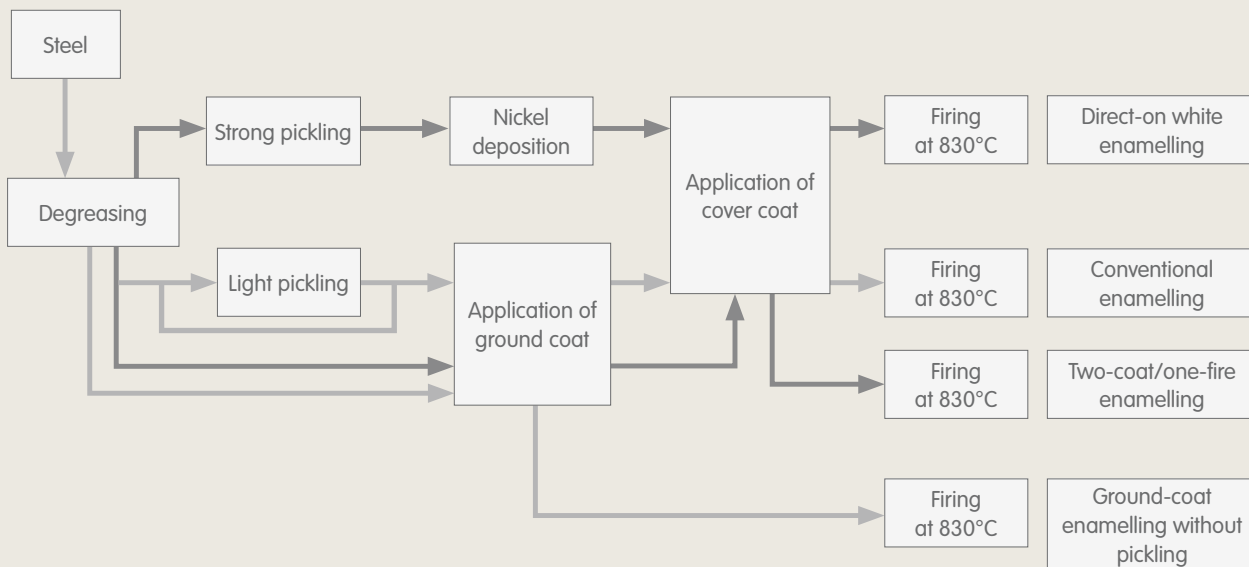

## 4.4 Low-temperature enamelling on aluminised steel substrates

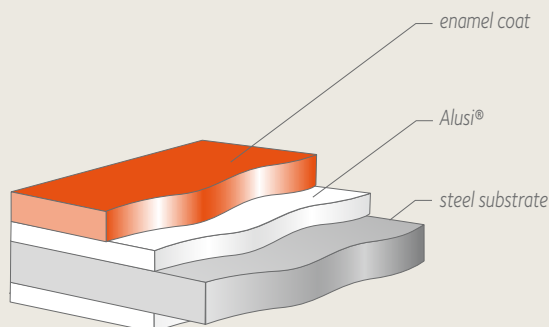

This process is performed on an aluminised steel substrate. The enamels used have been modified so as to ensure good adhesion on this type of substrate. The process entails applying enamel to just one side of the part to be coated, with the other side being protected from corrosion by the Al/Si alloy coating, then firing at a temperature of about 560°C (low-temperature firing).

## 4.4.1 Aluminised steels for enamelling: Alusi® BEC and Alusi® BEA

Aluminised steels for enamelling are coated with an alloy of 90% aluminium and 10% silicon. A special enamel suitable for this type of coating must be used for enamelling. After forming, these steels can be enamelled at low temperature by means of a simpler, more economical and environmentally friendly process than the conventional method on cold rolled steel.

There are two grades available: Alusi® BEC and Alusi® BEA.

Surface preparation of these grades consists of no more than very meticulous degreasing (no pickling). Only one coat of enamel, with a thickness ranging between 80 and 100 µm is required on one side only, the other side being protected naturally by the aluminium coating (which forms a highly resistant aluminium oxide layer during firing). Firing is performed at 560°C, preferably in a convection oven so as to keep the temperature of the enamelled part as even as possible in order to ensure a homogeneous colour. It is difficult to achieve a very glossy surface appearance after enamelling, however (max. specular gloss = 80%).

A wet or dry enamelling process may be used. The corrosion resistance of the non-enamelled side of the enamelled part is excellent: it can withstand the salt spray test for over 500 hours, in accordance with ISO 7253.

Finally, the use of aluminised steel for enamelling leads to cost savings of between 8 and 15% for the finished product compared with the conventional enamelling process on cold rolled steel.

#### 4.4.2 Application

The **Alusi® BEC** grade is especially suitable for enamelled catalytic self-cleaning oven cavity walls. Use of this steel rather than conventionally enamelled material has the advantage that it is not necessary to apply a ground coat of enamel. There is direct adhesion between the enamel and the substrate. Its performance during catalytic cleaning cycles is in compliance with ISO 8291.

The **Alusi® BEA** grade is designed for the enamelling of visible parts and can be used in the following fields of application:

- Enamelled casing parts for domestic appliances (hobs, front and side panels)
- Indoor architectural applications

#### 4.4.3 Use

##### Forming

Alusi® BEC and Alusi® BEA grades can be formed by bending, profiling or deep drawing. The aluminium coating has the advantage of increasing the friction coefficient. However, great care should be taken to avoid scratching the surface of the part, since this would produce surface blemishes after enamelling. The use of hard, polished, chromium-plated tools is recommended.

##### Joining

After suitable modification of the welding parameters for cold rolled sheet, Alusi® BEC and Alusi® BEA grades can be welded without any difficulty, whatever the welding processes may be (spot welding, TIG, MIG, MAG etc). Other joining processes (clinching, lock seaming) may also be used.

#### Enamelling

##### Surface preparation

- Surface preparation is very important. It is crucial, especially with **Alusi® BEA** grade, to perform meticulous alkaline degreasing followed by hot and cold rinsing, using demineralised water for the final rinse, in order to obtain a good surface appearance after enamelling.

##### Application of the enamel and firing

- With **Alusi® BEC** grade, the catalytic enamel coating can be applied by a wet or dry process. Firing is performed at a temperature of 560°C.
- **Alusi® BEA** grade can be enamelled with a matt or glossy enamel suitable for firing at a low temperature, applied by a wet or dry process. It is fired at 560°C. A convection oven must be used in order to guarantee a homogeneous colour after enamelling.

Thickness (mm)	0.6	1.2	2.0
Welding current (kA)	9.9 to 12.7	10.6 to 12.1	10.9 to 12.4
Welding latitude (kA)	2.8	1.5	
Positioning time (periods)			
Welding time (periods)	10	12	24
Holding time (periods)			
Electrode pressure (daN)	330		550
Type of electrode	Flat – 6 mm		

*Spot welding of Alusi® BEC and Alusi® BEA grades*





## 5 Forming of steel for enamelling

5.1	Transport and storage	32
5.2	Decoiling, slitting and cutting	32
5.3	Forming	33
5.3.1	Bending	33
5.3.2	Deep drawing	34

## 5 Forming of steel for enamelling

### 5.1 Transport and storage

Some simple yet nevertheless essential precautions should be taken for the transport and storage of steel:

- Coils, sheets and blanks should be kept in heated or ventilated storage facilities to ensure that no moisture accumulates
- In particular, coils, sheets and blanks should not be stored near windows, doors etc, to avoid extreme variations in temperature that could produce condensation
- During transport, and if outdoor storage is unavoidable, the coils, sheets and blanks should be protected
- Avoid storing the products directly on the floor

### 5.2 Decoiling, slitting and cutting

The drive system for decoiling must be adjusted to match line speed in order to optimise product flow. In extreme circumstances on some processing lines, the drive system will also eliminate jogs, flapping and slippage of adjacent wraps, and, in the case of hot rolled steel, "coil break" defects.

For slitting and other cutting operations, tools should be correctly adjusted and sharpened so as to minimise the formation of burrs.

Slitting, cutting-to-length and shearing operations should be included in process design from the outset, to ensure that any burrs formed do not detract from the appearance of the parts or pose a risk of cutting during handling. The following rules should be observed to control the location of burrs after cutting:

- Slitting and side trimming wheels should preferably be mounted symmetrically
- Clearances must be properly adjusted

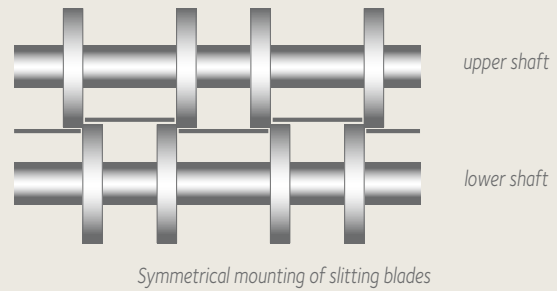

*Symmetrical mounting of slitting blades*

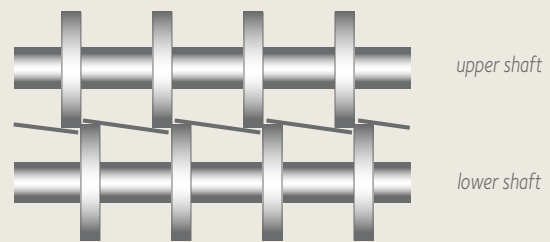

*Non-symmetrical mounting of slitting blades*

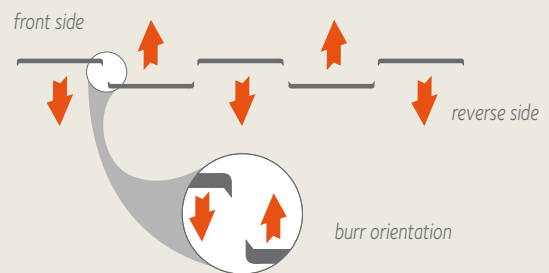

*Burr orientation after slitting*



The slitting quality is considered to be good if:

- The distorted zone is small
- The shear zone is roughly a third of the thickness
- The fracture zone is sharp, with an angle of less than 5°
- There are few or no burrs

Cutting to length on a shearing line produces burrs oriented in opposite directions on the front and reverse sides of the steel sheet. This aspect is important, since it means that it is essential to stack the sheets perfectly vertically.

The use of disk cutters and similar techniques is not recommended, since they produce chips and high burrs.

Laser or plasma cutting techniques can also be used. Their advantages are high precision and the absence of burrs.

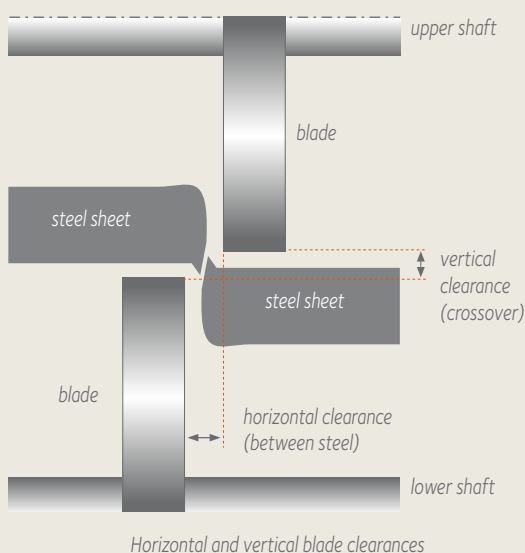
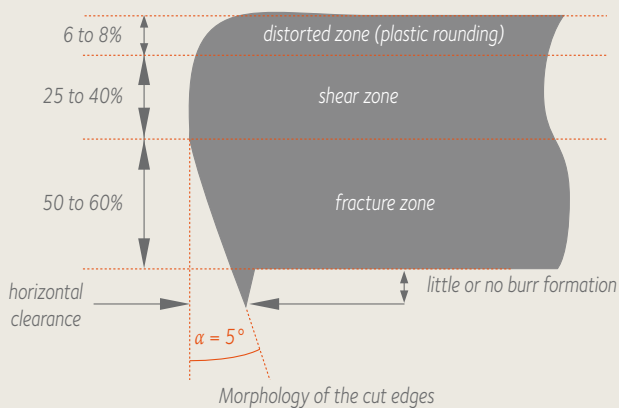

### 5.3 Forming

There are two main techniques for forming steel for enamelling:

- Bending, which is mainly used for making panels (architectural and signage applications)
- Deep drawing, which is particularly used in the domestic appliance and sanitary ware industries

#### 5.3.1 Bending

In conventional sheet steel processing, bending is the most severe operation and determines the steel grade to be selected.

During the bending process, the metal is bent over the tool; if there is no friction or external tension, there should be equilibrium between the elongation of the exterior fibres and the compression of the interior fibres. But friction detracts from the compression of the latter, and tension increases the exterior fibres' tendency to elongate. The neutral fibres move in the direction of the tool and the sheet becomes thinner. This thinning obviously results in a loss of strength, and any tension applied would soon cause rupture, if the resistance of the metal to deformation had not been increased by work hardening. The important property is therefore its work hardening capacity, indicated by the strain hardening coefficient  $n$ .

Different bending techniques may be used: narrow punch V-bending, flap bending, automatic panel forming or edge forming.

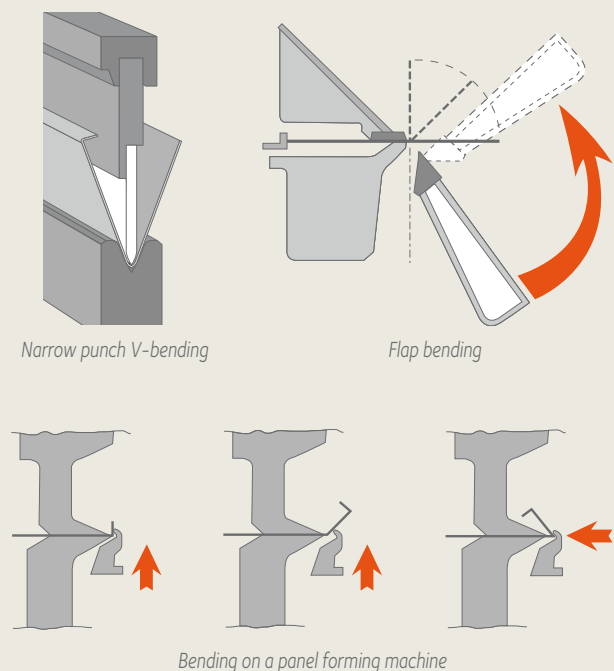

## 5.3.2 Deep drawing

Deep drawing is the processing operation that makes it possible to exploit the formability of sheet steel to the maximum.

The success of a deep drawing operation depends on the optimisation of manufacturing parameters and meticulous fine-tuning.

The material itself is obviously the first of the many parameters that can be adjusted. The choice of a steel grade to produce a given shape depends initially on the assumption that the properties of the finished part will be such that it can withstand the stress indicated in the specifications. Regarding the forming it will undergo, this means that the formability of the steel (rheological aspect) and its surface properties with respect to contact between the steel and the tool (tribological aspect) must be appropriate for the shape to be produced, the required appearance of the final product, and the expected cost.

### The mechanical properties of steel

In the context of forming steel sheets, it is worth remembering that they will react very differently, depending on how stress or strain is applied.

The most commonly used mechanical properties are those that can be determined by a uniaxial tensile test. This test has the advantage of being simple to execute and providing a large amount of data at the same time. The following mechanical properties can be determined by this test:

- $R_{eL}$ , yield strength, stress level above which deformation becomes plastic and therefore permanent
- $R_m$ , ultimate tensile strength or breaking load
- $A$  (%), elongation at rupture
- $r$ , Lankford coefficient (plastic strain ratio), which expresses the ratio of the true width strain to the true thickness strain for a given elongation (usually 25%). It gives a good idea of the capacity of the sheet to deform in deep drawing mode and varies according to the orientation of the sheet specimen axis.
- $n$ , strain hardening coefficient, which indicates the steel's capacity to harden when plastic deformation takes place

These properties only represent an imperfect description of the behaviour of steel in one simple example of a forming operation: uniaxial tension.

### Different deformation modes

There are two deformation modes: expansion and deep drawing:

- Expansion is characterised by an increase in the surface area of the steel sheet and therefore a reduction in thickness (since the volume of the material remains the same), which can lead to rupture of the steel in extreme cases. This deformation mode can be seen in the top section of the drawn component in the figure below.
- Deep drawing mode is caused by a compressive stress in the steel sheet, which may lead to an increase in the thickness of the material or wrinkling.

These two deformation modes coexist during the drawing process; the solution is to find the best compromise between deep drawing mode (wrinkling) and expansion (rupture or necking).

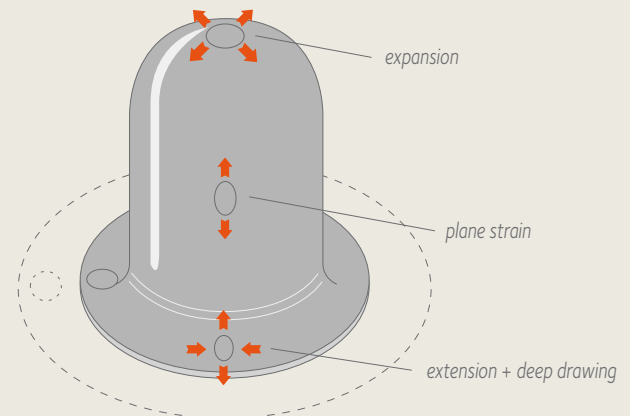

Different deformation modes in a drawn component

## Forming limit curves

Two methods exist to express these variations in mechanical properties:

- By evaluating the stresses; various plasticity criteria (Tresca, Von Mises, Hill etc) can be used to determine equations for the behaviour of the metal in all deformation modes, starting with simple uniaxial tension
- By evaluating the deformation; an indispensable indicator is used in this field: the Forming Limit Curve or FLC

For a steel sheet of a given grade and thickness, the FLC determines a safety limit for deep drawing operations ( $\epsilon_1/\epsilon_2$  range), superimposed on strain values representing the deformation as a whole. This curve can be established according to various acceptance criteria: necking or rupture of the steel, wrinkling, excessive thinning of the metallic coating, cracking or peeling of the coating.

This curve allows the user to:

- Evaluate the safety margin for the drawn component
- Identify critical areas of the component where the material is subjected to severe deformation
- Analyse the factors that influence forming: steel grade, component design, lubrication, tool design (draw beads, radii etc)



Example of FLC for a steel for enamelling



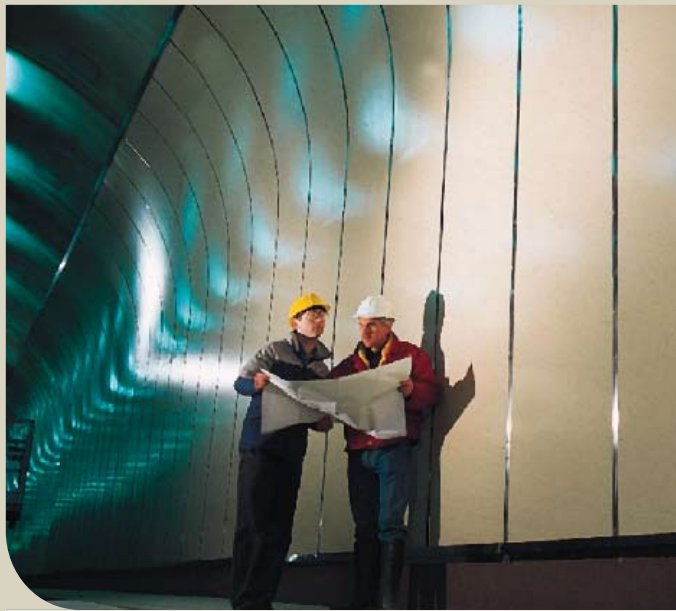

## 6 Joining of steel for enamelling

6.1	Clinching	38
6.2	Lock seaming	38
6.3	Welding	39
6.3.1	Resistance welding	39
6.3.2	Gas shielded arc welding	40
6.3.3	Welding fumes	41
6.3.4	Reconditioning	41

Steel for enamelling is compatible with many commonly used metal joining techniques: clinching, lock seaming and welding.

## 6.1 Clinching

Clinching is a discontinuous joining technique in which local joining points are produced by simultaneous deformation of two or more sheets of steel with the aid of a punch and die.

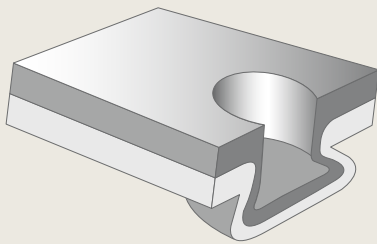

*Clinched joint*

This process requires neither preformed holes nor additional material. Since the joint does not need to be heated, there is no heat-affected zone.

Clinching is a clean process that produces no fumes or slag; it is relatively quiet and uses little energy. It can be easily automated and easily integrated into a manufacturing line.

Regarding the appearance of the sheets, each clinched joint produces a hump and a hollow, which may limit their suitability for certain applications.

Since the static strength of a clinch is lower than that of a spot weld (30–70% of spot weld strength), a greater density of clinched joints is required. The clinching tool must be perfectly perpendicular to the sheets and the punch must be very precisely positioned with respect to the die.

The following guidelines must be observed for clinching:

- The thinner sheet should not be less than half the thickness of the thicker sheet
- The maximum thickness after joining is 6 mm
- This maximum thickness can be decreased if the steel used has greater mechanical strength

The ease of clinching of a steel sheet is directly linked to the grade of steel employed. To guarantee the attractive appearance of the clinched joints, localised lubrication with a volatile oil may prove necessary to limit friction between the punch, the surface of the steel and the die.

## 6.2 Lock seaming

The term lock seaming covers all the mechanical processes for producing a joint by plastic deformation of at least one of the components involved.

Lock seaming can be used to join steel for enamelling, provided that the steel grades are chosen to withstand the strains generated in the folds.

However, lock seaming is only suitable for parts with a geometrically simple design, and cannot be used for corners.

Lock-seamed joints cannot be dismantled, and have a low resistance to slipping in a direction parallel to the folds and a low resistance to joint opening.

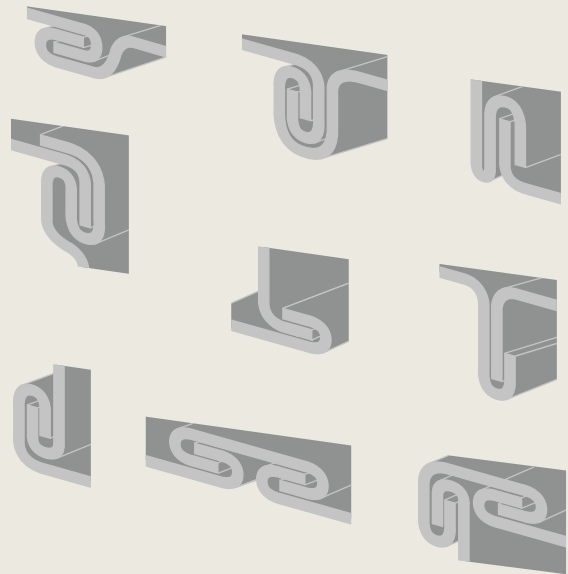

*Different single and double lock seams*

## 6.3 Welding

Resistance welding is the most common welding process, though arc welding techniques are used for some applications.

### 6.3.1 Resistance welding

#### Resistance spot welding

This is a complex process including electrical (passage of an electric current), thermal (dispersion of heat energy), mechanical (application of significant pressure) and metallurgical aspects, whereby the aim is to generate heat by the passage of an electric current, and then the local fusion of the two steel sheets.

The electrical aspects of the process can be described as a succession of ohmic resistances, the relative values of which produce local heating. The strength of the contact resistance between the two sheets governs the formation of the weld nugget at the site of the spot weld.

The key parameters to check are applied pressure, current intensity and welding time.

To extend the life span of the welding electrodes, they must be cooled during long production runs by internally circulating cooling water at 20°C at a rate of 4-6 l/min.

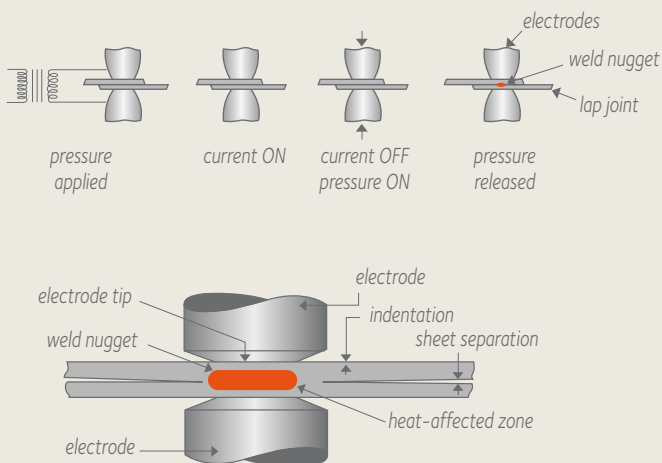

#### Resistance seam welding

Unlike resistance spot welding, resistance seam welding uses rotating electrode wheels. If possible, the seams should be welded discontinuously (Roll Spot), to limit heating of both the steel sheet and the electrodes (see figure c) on this page).

A variant of this process is to use an intermediate electrode with consumable copper wire (Soudronic patent). This method, which calls for a fairly precise guiding system for the placement of the copper wire, may be economically advantageous for long production runs, because when the welding parameters have been carefully optimised, this method can always guarantee excellent internal quality of the molten nuggets. This technique can be used with steel thicknesses of up to 1.2 mm.

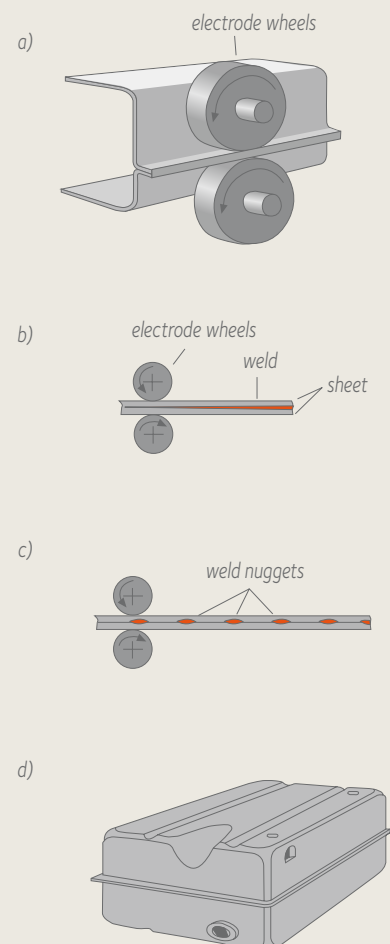

**Projection welding**

The projections are protuberances (bulges) with controlled geometrical dimensions, formed by deep drawing or machining of one of the workpieces to be joined. The passage of the welding current is localised right at the protuberance. Projection welding is an attractive alternative when welding relatively solid fittings onto a thin steel sheet, since the small volume of the protuberances will reduce the amount of heat taken up by the solid component during the welding process (e.g. mounting threaded nuts or bolts on car body parts (see figures g) and h) below).

To avoid premature failure of the weld, the pressure on the electrode must be controlled exactly. Welding time is usually short, particularly with thinner gauges of steel.

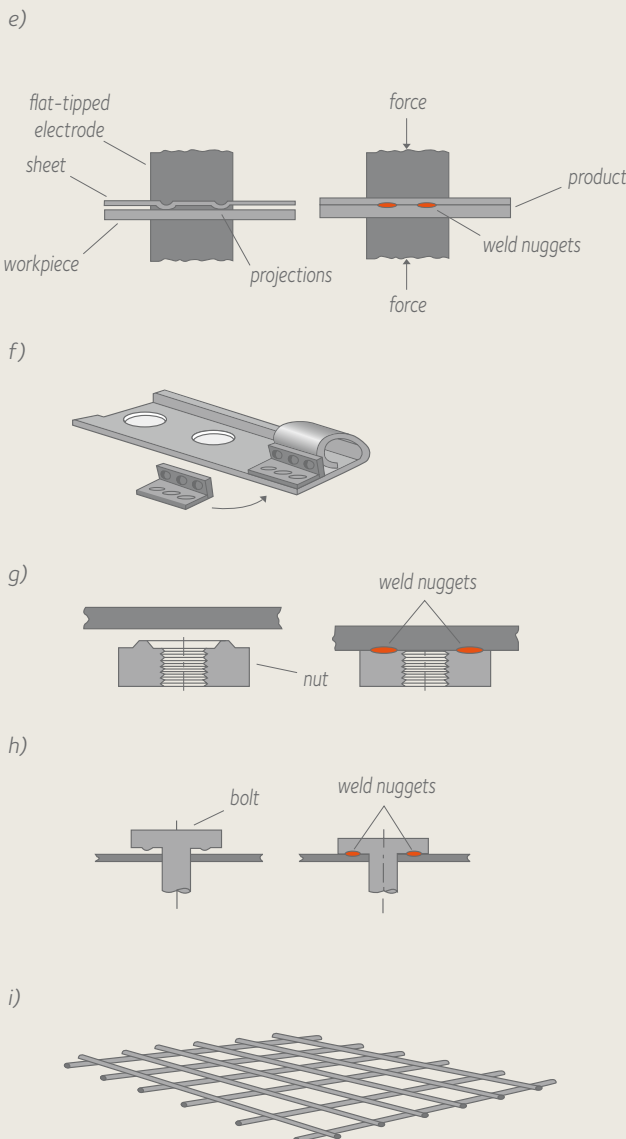

**6.3.2 Gas shielded arc welding**

The principle of electric arc welding techniques is the application of heat by striking a low-voltage arc between an electrode and the steel sheet.

There are several possible methods (plasma, TIG, MAG), but MAG is recommended because it is the most productive.

In MAG welding, the electrode is consumable and provides the filler metal. The molten metal is protected from corrosion by an active barrier gas: 100% CO<sub>2</sub>, binary Argon + CO<sub>2</sub> or tertiary Argon + CO<sub>2</sub> + O<sub>2</sub>.

This method can be used to join materials of a different type, and of any thickness.

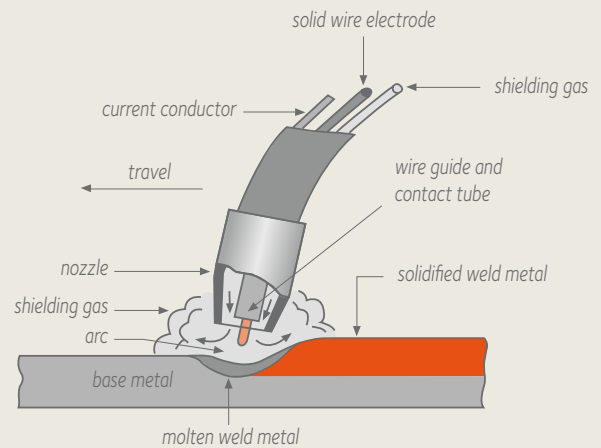

For MAG welding of thin sheets, the most common configuration is the superposition of the two sheets to be welded to produce a lap weld.

This welding method involves the addition of material to form the joint, which means that the finished part is not aesthetically pleasing, since the appearance of the weld itself is generally unattractive.

It is advisable to choose electrode wire with mechanical and chemical properties similar to those of the steel grades to be welded. Moreover, if the heat-affected zone (area around the weld) is too large, this may cause bubble-type surface blemishes after enamelling (local modification of the metallurgical properties of the steel).



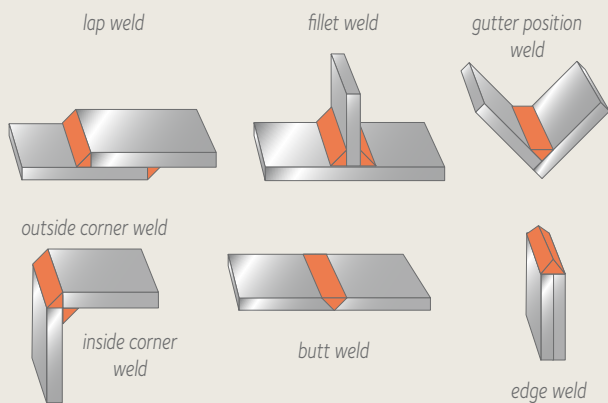

*Different weld configurations*

### 6.3.3 Welding fumes

Welding steel entails the formation of welding fumes. Consequently, the workplace should be suitably equipped to extract these fumes: extractor torch, extractor hood, glove box etc.

### 6.3.4 Reconditioning

In general, conventional welding processes produce a heat-affected zone around the weld, where the surface is altered. It may therefore be important to clean the surface immediately after welding has been completed, to remove any deposits, oxides and foreign bodies that may have appeared during the welding process.





## 7 Properties of enamelled steel

7.1	Enamel adhesion	44
7.2	Corrosion resistance	44
7.3	Chemical resistance of enamel	44
7.4	Mechanical strength of the surface	44
7.5	High and low temperature stability	44
7.6	Thermal shock resistance	44
7.7	Fire resistance	44
7.8	Hygiene and ease of cleaning	45
7.9	Colour stability	45

## 7 Properties of enamelled steel

Enamelled steel has a number of useful properties that are chiefly due to the vitreous nature of the enamel. The chemical composition of enamel varies according to its end use so as to fully meet the required characteristics.

### 7.1 Enamel adhesion

The enamel must adhere to the substrate in order to ensure that the enamelled steel has the required properties for each end use. Adhesion is determined by means of an impact test, which entails deforming a sample of enamelled sheet using a hemispherical punch by dropping a 1.5 kg weight onto the punch from a height appropriate for the thickness of the substrate.

The degree of adhesion is determined by comparison with reference photos. The score given ranges from 1 (very good adhesion) to 5 (very poor adhesion).

### 7.2 Corrosion resistance

Enamel is a coating that provides steel with excellent corrosion resistance, even at high temperatures. Enamelled surfaces are non-porous and hence impermeable to all liquids. Salt spray tests performed on enamelled parts with a cold rolled or aluminised substrate indicate that they can withstand salt spray for over 500 hours without showing any signs of red rust. Tests conducted by the Porcelain Enamel Institute have shown that enamelled panels could go for 30 years without any signs of corrosion on the metal substrate.

### 7.3 Chemical resistance of enamel

The chemical properties of enamel are tailored to the environment in which it is to be used. Enamel thus has extremely good resistance to chemicals: acids (apart from hydrofluoric acid), alkalis, detergents and organic solutions. Whether used in kitchens or bathrooms, contact with a variety of foodstuffs, perfumes, cosmetics or cleaning products will have no effect whatsoever on the surface of these products.

Enamelled steel is also extremely resistant to atmospheric attack. Consequently, rain, atmospheric pollution (sulphur dioxide, nitric oxide), salt-laden marine atmospheres, ultra-violet radiation and sudden changes in temperature will not lead to any changes in the appearance, colour or gloss of the enamelled surface.

### 7.4 Mechanical strength of the surface

Like glass, the surface of enamelled steel is very hard, which means that it is extremely resistant to scratching, abrasion, impact and wear. Hardness is classified as between 5 and 7 on the Mohs scale.

One of the benefits of the surface hardness of enamelled steel is that it is extremely resistant to abrasion, which explains why it is so widely used in many fields such as domestic and sanitary equipment.

Abrasion resistance is determined by means of a friction test.

### 7.5 High and low temperature stability

Thanks to their vitreous nature, enamelled surfaces have excellent temperature stability. Some applications, especially in the domestic appliance sector (pyrolytic self-cleaning ovens) and in industry, require operating temperatures of about 450°C to 500°C.

Enamelled steel can also be subjected to temperatures of -60°C without any adverse effects on the enamel (we are able to offer steels that are very resilient at this temperature).

### 7.6 Thermal shock resistance

Enamel is able to withstand wide temperature variations in excess of 100°C without undergoing any damage. It can therefore be used in applications where such variations are found: cooking appliances, domestic equipment, exhaust systems.

### 7.7 Fire resistance

A flame or any other source of heat will cause no damage to an enamelled surface. In addition, enamel will not give off any toxic fumes in the event of prolonged exposure to heat.

The fire resistance of enamelled panels is classified as A1.

## 7.8 Hygiene and ease of cleaning

The smooth, hard vitreous surface of enamelled steel has no pores or cracks, which prevents the growth of bacteria and the accumulation of dust. Enamelled steel can therefore be used in sensitive areas such as clean rooms or kitchens.

Thanks to everyday usage it is also widely known that enamelled steel is a food-grade material that does not give off odours.

Enamelled surfaces are very easy to clean, especially if defaced by graffiti. Enamel's smooth, sealed surface and its exclusively mineral composition mean that commercially available solvents can be used for cleaning purposes, making it much easier and less expensive to clean. The savings made may be considerable. Enamelled steel is thus a material that can be used in places where surface cleanliness is very important (e.g. tunnels), or in places subject to graffiti attacks.

## 7.9 Colour stability

Enamelled steel comes in an almost infinite range of colours, patterns and textures with a gloss, semi-matt or matt finish. In addition, it is possible to reproduce any image with extreme accuracy by screen printing, e.g. signs, posters, works of art or photographs. If the process is performed at a high temperature, these images will last as long as the rest of the enamelled panel.

Since the colours are created using mineral pigments, they display considerable stability over time. One particular feature is that they are not sensitive to UV.



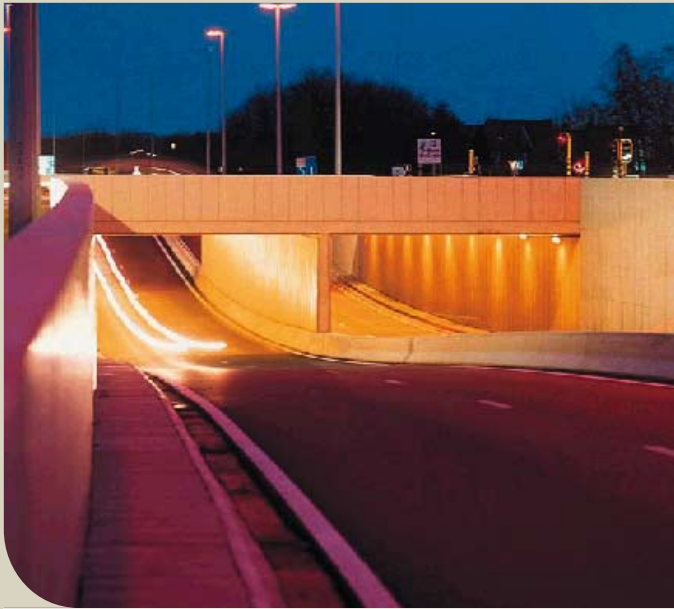

# 8

## Enamelled steel and the environment

8.1	The production process	48
8.1.1	Environmental risks associated with surface treatment	48
8.1.2	Environmental risks associated with enamelling	48
8.1.3	Environmental risks associated with firing the enamel	48
8.2	Life cycle and disposal of the enamelled product	48

The criteria associated with **sustainable development** are such that assessing the **ecological value of a particular product** is not just a case of considering the **materials required to manufacture the product** and any associated **waste products**, but also evaluating the **environmental impact of the product itself** during its lifetime and when it is eventually disposed of.

The environmental impact of enamelled steel must therefore be considered on two levels:

- During manufacture of enamelled parts
- During their life cycle and disposal

## 8.1 The production process

Enamelling on steel is a relatively complex process and there are environmental risks associated with each stage. Advances made in all areas have tended to reduce these risks.

### 8.1.1 Environmental risks associated with surface treatment

Surface treatment can sometimes be very complex and, in the case of direct-on white enamelling, may include degreasing, pickling, nickel deposition and rinsing. These various operations use a great deal of water, energy and chemicals, which generate vapours and waste that need to be treated.

Ensuring that a surface treatment line of this kind complies with current legislation requires investment in a waste treatment plant, which can double the operating cost of surface preparation.

ArcelorMittal endeavours to develop products that respect the environment and that are simpler to use. We are therefore currently perfecting surface coatings that will make it possible to simplify, or possibly dispense with, surface treatment before enamelling.

### 8.1.2 Environmental risks associated with enamelling

When enamel is supplied to the enameller in the form of frit, the enameller needs to grind the frit and prepare a suspension in water after incorporating the necessary additives (suspension, refractory, colouring agents, electrolytes and opacifiers). This method means that the waste produced during this process must be treated, and likewise the water used.

Enamel manufacturers have therefore developed **ready-to-use enamels** that are supplied in powder form, enabling this process to be dispensed with. These enamels are mixed with water prior to application. The enamelling booths do need to be cleaned meticulously after each application cycle in which these enamels are used. The resulting waste must be disposed of.

The development of enamel application methods based on **electrostatic powdering circumvents this disadvantage**. In fact, 99% of the enamel ends up on the part and the rest can be recovered for re-use. The even thickness of the enamel coating also means that this method yields **enamel savings** of between 20% and 30% compared with wet application processes.

### 8.1.3 Environmental risks associated with firing the enamel

The main risks are associated with the release of small quantities of fluorine during the enamel firing stage, though this corrosive element is less and less likely to be present in modern-day enamels.

Furthermore, firing furnaces are now equipped with exhaust gas treatment systems, which considerably reduce the amount of pollution discharged to the atmosphere.

## 8.2 Life cycle and disposal of the enamelled product

The qualities of enamelled steel make it a very modern material that complies with the latest environmental regulations. Enamel enhances steel by considerably extending its life span. No other steel coating (metallic, organic) can give steel this level of durability.

Enamelled steel is also a **material that is very easy to recycle**. It has the advantage over other materials of being classified as a **recoverable material** and not as waste. It does not give off toxic fumes or produce other dangerous substances when disposed of. It is 100% recyclable without the need for any preliminary treatment.





## 9 Uses of enamelled steel

9.1	<b>Domestic uses of enamelled steel</b>	<b>50</b>
9.1.1	Electric water heaters	50
9.1.2	Domestic appliances and cookware	50
9.1.3	Sanitary ware	50
9.2	<b>Enamelled steel and the construction industry</b>	<b>51</b>
9.2.1	Outdoor applications	51
9.2.2	Indoor applications	51
9.2.3	Recommendations for installation	51
9.3	<b>Other applications of enamelled steel</b>	<b>52</b>
9.3.1	Applications in industry	52
9.3.2	Sign panels	52
9.4	<b>Summary of the principal uses of steel for enamelling</b>	<b>53</b>

## 9.1 Domestic uses of enamelled steel

### 9.1.1 Electric water heaters

An electric water heater consists of an external protective casing, insulation, an inner tank containing the water to be heated and a heating element. The element converts electrical energy into heat, which is conveyed to the cold water in the lower part of the water heater. Water circulates in the tank by convection and its temperature is controlled by a thermostat.

**Enamel** covers the **inner wall** of the tank, protecting it from corrosion. Furthermore, since enamel is a food-grade material, the water can also be safely used in the kitchen.

In view of the thickness that needs to be used (the tank is regarded as a pressure vessel and must be tested at about 12 bar), the steels used for the tank are hot rolled: **S240EK** and **S300EK** grades.

### 9.1.2 Domestic appliances and cookware

The domestic appliance market is the biggest user of steel for enamelling. Enamelled steel is in fact the only material capable of withstanding the many stresses to which appliances are subjected, particularly in cooking applications. It has therefore become indispensable for specific applications where it is unrivalled: hobs, oven cavities, dripping pans, baking trays etc.

Here are just some of its many useful properties:

- Resistance to scratching and abrasion is much better than with other materials
- Enamelled steel neither retains nor absorbs odours, so it cannot impart them
- It is resistant to products commonly used in the kitchen, whether they be acidic (e.g. vinegar and lemon juice) or alkaline (e.g. detergents), and also has excellent corrosion resistance
- It is flame-resistant and can withstand a high temperature
- It is safe for contact with food and prevents the growth of bacteria
- It is very resistant to steam, which means it can readily be used for this cooking method
- It has undeniable aesthetic qualities

Advances in enamel design in the past few years have led to the development of self-cleaning oven cavities:

- Pyrolytic self-cleaning oven: the principle involves heating the oven cavity to a high temperature, about 500°C, so as to burn fats and residues deposited on the walls when food is cooked.
- Catalytic self-cleaning oven: in this case, cleaning takes place at normal cooking temperatures. Enamel contains a catalyst that speeds up the oxidation of fats and the breakdown of residues.
- Use of Easy-to-Clean (ETC) enamel: the absence of micropores in the completely smooth surface of enamel prevents any accumulation of dirt.

Enamelled steel is also used for cookware: enamelled saucepans prevent the growth of bacteria, do not absorb odours, are not attacked by food acids and can be used directly on the gas hob. They have a very smooth surface that is highly resistant to the abrasive and chemical effects of ordinary detergents, and can be cleaned very easily. They are also suitable for use in induction cooking, which has great potential.

### 9.1.3 Sanitary ware

The sanitary ware market also exploits the qualities of enamelled steel. The properties of the steels available nowadays make it possible to design and offer a wide range of bathtubs, wash-hand basins and sinks in a variety of shapes and sizes to meet the requirements of even the most demanding consumers. Enamel can be decorated in a multitude of ways, producing a wide range of finishes. But the product really excels when it comes to its hygiene and sanitary qualities. It is completely inert, both chemically and mechanically. Besides not harbouring bacteria, the enamelled surface can be cleaned very easily using even the most aggressive products. If cared for properly, it will always look brand new.

## 9.2 Enamelled steel and the construction industry

Enamelled steel has many applications in construction. It can be used as a cladding for buildings or tunnels and in the interiors of public places, such as train and metro stations, airports and other buildings, as a wall-covering and for false ceilings, partitions and lifts.

Enamelled steel is also an excellent material for fitting out clean rooms.

### 9.2.1 Outdoor applications

Weather and UV resistant, with virtually unlimited scope for decoration, enamelled steel is the ideal solution for outdoor applications.

Enamelled panels are particularly suitable for separation walls or for cladding more traditional brickwork buildings. They are prefabricated by the enameller to match the exact dimensions of the building in question. This technique has obvious financial advantages over conventional building methods. The panels can be installed in any weather, irrespective of the outside temperature.

Due to the durability of the colours (colour stability can be guaranteed for 40, even 50 years), enamelled panels can be replaced when a building is being renovated or extended without any noticeable difference in colour. Consequently, it will not look as if the work had been done at two different times.

The ease with which graffiti can be cleaned off is readily demonstrated when the building is located in an area that is prone to graffiti attacks.

The use of enamelled steel for lining tunnels is recommended, as it makes them easier and cheaper to clean, ensures better illumination (the enamelled surface reflects light well, which means that less investment in lighting is required) and improves fire resistance.

There are also other possible applications, such as sound-proof walls, water storage tanks, pipes and water-treatment plant systems, where the use of enamelled steel highlights its resistance to corrosive agents and to the proliferation of bacteria.

### 9.2.2 Indoor applications

Enamelled steel is a very popular choice for fitting out public places. Flame resistant, vandal-proof, easy to maintain and offering virtually unlimited scope for decoration, it is ideal as a wall-covering and for ceilings, partitions, lift cars etc.

It is therefore used in:

- Metro stations
- Train stations
- Airports
- The interior decor of ships

Since it is free of bacteria and is not affected by moisture, it is also the perfect solution in hospitals, clean rooms and sanitary systems.

### 9.2.3 Recommendations for installation

The installation of enamelled cassette trays, for both building cladding and interior decoration applications, requires a few precautions to be taken.

In view of the properties of enamel, it is usually impossible to modify an enamelled panel. No bending, cutting or drilling can be performed, as this would damage the enamelled surface. Good site preparation is therefore very important for the architect or the building project manager. A very accurate layout drawing of the surface to be clad will guarantee success and, unlike other types of panels such as lacquered board, the installation tolerance is very low. It is therefore vital to know in advance the exact dimensions of all the panels and also the position of all the holes that will be used to hang them from the façade or wall in question.

The thickness generally used is between 1.5 and 3 mm, and the widths about 1500 mm (the feasible dimensions are limited by those of the enamel firing furnace). It is possible to use thicknesses as low as 0.3 mm, in which case the panel is glued to a more rigid sub-frame (steel, aluminium etc). For the manufacture of the cassette trays, bending radii of about 3 mm are recommended. The corners may be either deep drawn ("suitcase corner" deep drawing), or welded. The latter technique has the drawback that it is always more difficult to apply enamel on top of a weld. Surface blemishes or pores in the enamel can actually appear on the bead or the heat-affected zone if welding is not performed properly.

Firing enamelled cassette trays at high temperature can cause them to deform. This is why it may be necessary to laminate backing boards on the inside of the panels so as to make them flat. Various types of backing boards may be used: aluminium or galvanised steel sheets, wood, aluminium honeycomb structure, cardboard or polymer. The choice of material used will depend on where it is to be used, outdoors or indoors, and the thickness of the initial panel.

In order to clad columns or pillars, it is possible to make panels with a semi-circular profile. Since, in this case, the panel produced is more rigid, a backing board is unnecessary.

In view of the thickness of enamelled panels and the possible laminate applied, they vary between 15 and 30 kg/m<sup>2</sup> in weight. All necessary precautions must therefore be taken in handling them, particularly during installation on façades or walls.

The technique for installing enamelled cassette trays on a wall is identical to that used for any other metallic facing. The cassette tray is laid on a horizontal and/or vertical framework made of profiles in galvanised steel, stainless steel or aluminium, integral with the wall to be clad. The panels are then screwed to this framework. The fixing system may be visible or invisible. Plastic spacers and washers protect the enamel from overtightening of the screws. The space thus created between the wall and the panel will also allow surface water to drain away, in the case of outdoor applications, thereby preventing corrosion. Furthermore, there must be sufficient space left between the cassette trays to allow for expansion. Lastly, the leak-tightness of the system can be improved, if necessary, by using silicon sealing mastic.

### 9.3 Other applications of enamelled steel

#### 9.3.1 Applications in industry

Enamelled steel also has important applications in industry, even in the most corrosive atmospheres, e.g. in the chemical and agro-food industries. Its resistance to chemicals and to fermentation makes it an excellent lining for silos, chemical reactors, dryers, closed tanks and other water-treatment plant storage systems. Furthermore, because of its resistance to high temperatures and heat reflection properties, it can be used in columns and heat exchangers. Its resistance to corrosion caused by combustion gases also makes it an excellent material for the manufacture of flue linings and exhaust manifolds.

#### 9.3.2 Sign panels

Enamelled steel is an ideal solution for indoor and outdoor sign & communication panels.

The surface will not be damaged by urban pollution, weather, UV or graffiti. It is fire resistant and offers a host of decorative possibilities, making it the best possible material for the most sophisticated graphic creations.

#### 9.4 Summary of the principal uses of steel for enamelling

Steel type	Process	Dedicated steels for the process	Other possible steels	Use
Hot rolled steels	Enamelling on hot rolled	S240EK S300EK		Water-heater tanks
Cold rolled steels	Ground enamelling	DC01EK DC03EK DC04EK DC06EK DC07EK	Solfer® Solfer®+ DC04ES	Oven cavities Inner doors Dripping pans
	Two-coat/two-fire enamelling	DC01EK DC03EK DC04EK DC05EK DC06EK DC07EK	Solfer® Solfer®+ DC04ES	Bathtubs Shower trays Architectural panels Signage
	Direct-on white enamelling	Solfer® Solfer®+		Hobs Covers Doors Architectural panels
	Two-coat/one-fire enamelling	DC04ES	Solfer® Solfer®+ DC06EK DC07EK	
Aluminised steels	Enamelling on Alusi®	Alusi® BEC		Catalytic self-cleaning oven cavities
		Alusi® BEA		Hobs Covers Doors



Market	Manufactured component	Corrosion resistance	High-temperature stability	Abrasion resistance	Impact resistance	Resistance to changes in temperature	Acid resistance	Alkali resistance	Resistance to cleaning products	Colour stability	Hygiene and ease of cleaning	Luminosity	Catalytic power	Ease with which graffiti can be cleaned off	Fire resistance	Longevity
Domestic appliances	Self-cleaning oven cavities		•	•		•	•		•		•				•	•
	pyrolytic		•	•		•					•				•	•
	catalytic		•	•		•					•		•		•	•
	Hobs	•	•	•	•	•	•		•	•	•	•			•	•
	Washing machine interiors	•	•			•	•	•	•		•					•
	Cookware	•	•		•	•	•			•	•				•	
Industry	Water heaters	•			•						•					•
	Bathtubs	•	•	•	•					•	•	•				•
Construction	Flues	•	•			•	•									•
	Roof tiles (US)	•				•				•		•				•
Architecture	Curtain walls	•		•	•					•		•		•	•	•
	Exterior wall cladding	•		•	•					•		•		•	•	•
	Signage (road traffic signs, advertising etc)	•			•					•		•		•		•
	Art									•		•				•
Miscellaneous	Top-of-the-range exhaust silencers	•	•		•				•							•



## 10 Appendices

10.1	Mechanical properties of steel for enamelling	56
10.2	Performance of enamelled steel	58
10.3	Recommendations for installing enamelled architectural panels	60

## 10.1 Mechanical properties of steel for enamelling

The mechanical properties of cold rolled, hot rolled and aluminised steels for enamelling are shown in the table below. The values refer to crosswise measurements.

## Mechanical properties of cold rolled steels for enamelling

	Thickness (mm)	R <sub>e</sub> (MPa)	R <sub>m</sub> (MPa)	A (%)	r 90	r average	n 90	
DC01EK	0.4 - 0.5	140 - 310	270 - 390	≥ 26				
	0.5 - 0.7	140 - 290		≥ 28				
	0.7 - 3	140 - 270		≥ 30				
DC03EK	0.4 - 0.5	140 - 280	270 - 350	≥ 28	≥ 1.4		≥ 0.17	
	0.5 - 0.7	140 - 260		≥ 30				
	0.7 - 2	140 - 240		≥ 32				≥ 1.2
	2 - 3							
DC04EK	0.4 - 0.5	140 - 260	270 - 340	≥ 32	≥ 1.6		≥ 0.17	
	0.5 - 0.7	140 - 240		≥ 34				
	0.7 - 2	140 - 220		≥ 36				≥ 1.4
	2 - 3							
DC04ES	0.4 - 0.5	140 - 260	270 - 340	≥ 34	≥ 1.6		≥ 0.18	
	0.5 - 0.7	140 - 240		≥ 36				
	0.7 - 3	140 - 220		≥ 38				
DC05EK	0.7 - 2	140 - 190	270 - 320		≥ 2		≥ 0.18	
	2 - 3			≥ 1.8				
DC06EK	0.4 - 0.5	120 - 210	270 - 320	≥ 36		≥ 1.6		
	0.5 - 0.7	120 - 190		≥ 38				
	0.7 - 2	120 - 170		≥ 40				≥ 1.4
	2 - 3							
DC07EK	≤ 3	80 - 160	270 - 350	≥ 40			≥ 0,20	
Solfer®	0.4 - 0.5	140 - 280	270 - 370	≥ 30				
	0.5 - 0.7	140 - 260		≥ 32				
	0.7 - 2	140 - 240		≥ 34				
Solfer®+	0.4 - 0.5	140 - 250	270 - 350	≥ 34				
	0.5 - 0.7	140 - 230		≥ 36				
	0.7 - 2	140 - 210		≥ 38				



Mechanical properties of hot rolled steels for enamelling

	Thickness (mm)	R <sub>e</sub> (MPa)	R <sub>m</sub> (MPa)	A (%)
S240EK	1.5 - 3	≥ 240	360 - 430	≥ 27
	3 - 6			≥ 34
S300EK	1.5 - 3	≥ 280	330 - 450	≥ 25
	3 - 4.5	≥ 260		≥ 30

Mechanical properties of aluminised steels for enamelling

	Thickness (mm)	R <sub>e</sub> (MPa)	R <sub>m</sub> (MPa)	A (%)	r 90	n 90
Alusi® BEC	0.5 - 0.7	< 260	< 380	≥ 28	≥ 1.3	≥ 0.18
	0.7 - 3			≥ 30		
Alusi® BEA	0.5 - 0.7	< 240	< 370	≥ 30	≥ 1.3	≥ 0.18
	0.7 - 1	< 230		≥ 31		
	1 - 3		< 365	≥ 32		

## 10.2 Performance of enamelled steel

The table below indicates the performance of enamelled panels intended for architectural use, which must comply with EN 14431.

Criterion	Reference standard	Brief description	Quality specification
Steel substrate	EN 10209	EN 10209 describes the criteria that steel grades must meet to be defined as suitable for vitreous enamelling and also the test methods used to determine suitability for enamelling (hydrogen permeation, iron loss for steel intended for direct-on white enamelling, and enamel adhesion test).	Cold rolled low carbon steel flat products for vitreous enamelling
Enamel application	ISO 2178	Application of at least two coats of enamel on the visible side of the panel and one coat of enamel on the reverse side. The firing temperature must be at least 500°C. The coating thickness is measured using an elcometer (eddy current testing).	The coating thickness on the visible side varies from 75-275 µm if the thickness of the substrate is less than 0.75 mm, and from 180-500 µm if the thickness of the substrate is more than 0.75 mm.
Enamel adhesion	EN 10209 (annex D)	The sample of enamelled sheet is deformed using a hemispherical punch by dropping a 1.5 kg weight onto the punch from a height appropriate for the thickness of the substrate. The degree of adhesion is determined by comparison with reference photos and ranges from 1 (good adhesion) to 5 (poor adhesion).	Class 1, 2 or 3
Enamel porosity	ISO 8289 (method A) ISO 2746	A potential difference of 1000 V is applied between the enamelled surface and an electrode. Sparking indicates the presence of a pore in the enamel.	Maximum: 5 defects/m <sup>2</sup>
Abrasion resistance	ASTM C501	The aim of this test is to determine the weight loss of a sample subjected to friction from an abrasive wheel loaded with a constant weight. Abrasive: emery paper S33 Test load: 1 kg	The maximum weight loss after 1000 cycles must not exceed 0.1 g/m <sup>2</sup> .
Impact resistance	ISO 4532	This test is conducted using an impact pistol set at a force of 20 N to strike the sheet.	24 hours after the test, there must be no enamel cracks larger than 2 mm in diameter right at the point of impact.
Surface hardness (Mohs)	EN 101	Surface hardness is measured by the Mohs scale, which rates minerals according to their hardness from 1 (calcite) to 10 (diamond).	Minimum hardness is 5.
Scratch test	ISO 15695	The surface is scratched with needles to which is applied, by means of an arm, a force ranging from 1-20 N.	The enamelled surface must be able to withstand a force of 7 N without scratching.
Flatness		Flatness is determined by measuring the difference in deflection of the panel in its non-enamelled state and after firing. The measurement is performed on the long diagonal.	Thickness of substrate > 0.75 mm: Maximum deflection: 0.5% in the convex direction and 0.25% in the concave direction Thickness of substrate < 0.75 mm: Maximum deflection: 0.15% in both directions



Criterion	Reference standard	Brief description	Quality specification
Corrosion resistance	ISO 7253	Salt spray test: a sample is exposed to salt spray for a specific period of time. The degree of delamination of the coating and the proportion of rust on the surface define the level of corrosion.	No surface corrosion defects after 500 hrs of exposure to salt spray
Acid resistance	ISO 2722	Acid resistance is determined by placing the sample in an aqueous solution of 10% citric acid at room temperature for 15 minutes. The measurement is performed according to a reference norm.	Class A minimum according to the reference norm
	ISO 2742	Acid resistance is determined by placing the sample in an aqueous solution of boiling 6% citric acid for 150 minutes. Acid resistance is determined by weight loss.	Maximum weight loss: 18.5 g/m <sup>2</sup>
Surface appearance		The enamelled surface is observed under natural light from a distance of 1.5 m.	The enamelled surface must be free of defects likely to spoil the general appearance of the enamelled part.
Gloss	ISO 2813	The specular reflection of the coated product is measured using a glossometer: - matt appearance: measurement angle of 85° - glossy appearance: measurement angle of 60°	Generally, variations in the panel must not exceed 10 gloss units (agreed beforehand by the parties involved).
Colour	ISO 7724	Measurement of the difference in colour of a sample compared with a reference standard: - either visually - or using a colorimeter	The measuring method and the tolerated difference in colour are agreed beforehand by the parties involved.
UV resistance	ISO 4892	The sample is exposed to cyclical UV radiation for 1000 hours (a cycle consists of 4 hours' exposure to UV radiation at a temperature of 60°C followed by 4 hours' condensation without radiation at a temperature of 40°C).	Measurement of the colour and gloss before and after the test
Resistance to graffiti		Cleaning of the enamelled surface	It must be possible to easily clean off ink, varnish, lacquer and paint after they have aged for 8 days, using appropriate solvents, without any change in colour or gloss of the surface.
Reaction to fire	CSTB	Standardised tests to determine reaction to fire	Class A1 (ex M0)
Low-temperature stability		Resistance to cold	-60°C (in so far as the steel is sufficiently resilient at this temperature)
High-temperature stability		Resistance to heat	450°C

10.3 Recommendations for installing enamelled architectural panels

A few examples of fixing systems:

Omeras fixing system

Fixing of a rainscreen cladding

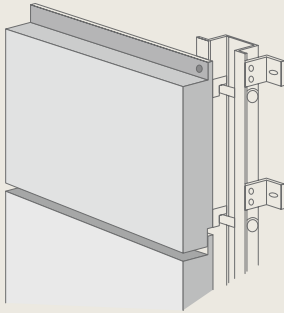

Sub-frame in hot dip galvanised steel or stainless steel, variable joints, enamel panels 1.5 mm thick plus backing board

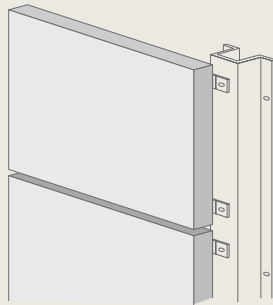

Fixing of flat enamel panels in a tunnel. High-quality stainless steel sub-frame

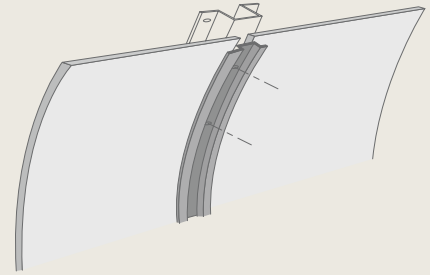

Fixing system used for the new Girod building

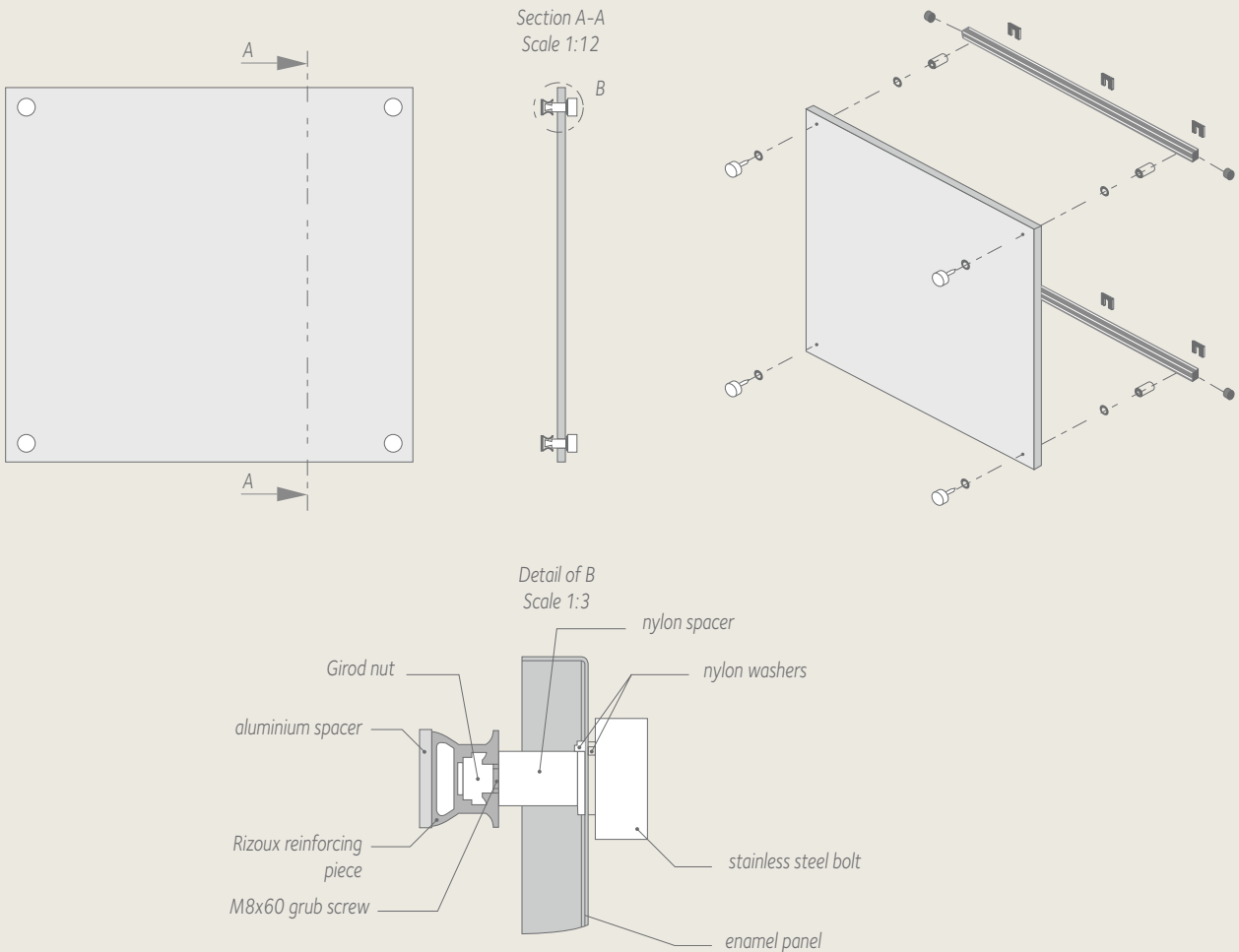

### PMA fixing system for BS Cassettes

The BS Cassette system comprises a supporting framework onto which are fixed the facing and specific fittings. Since the framework is designed to the dimensions of the cassette trays, there are no standard dimensions.

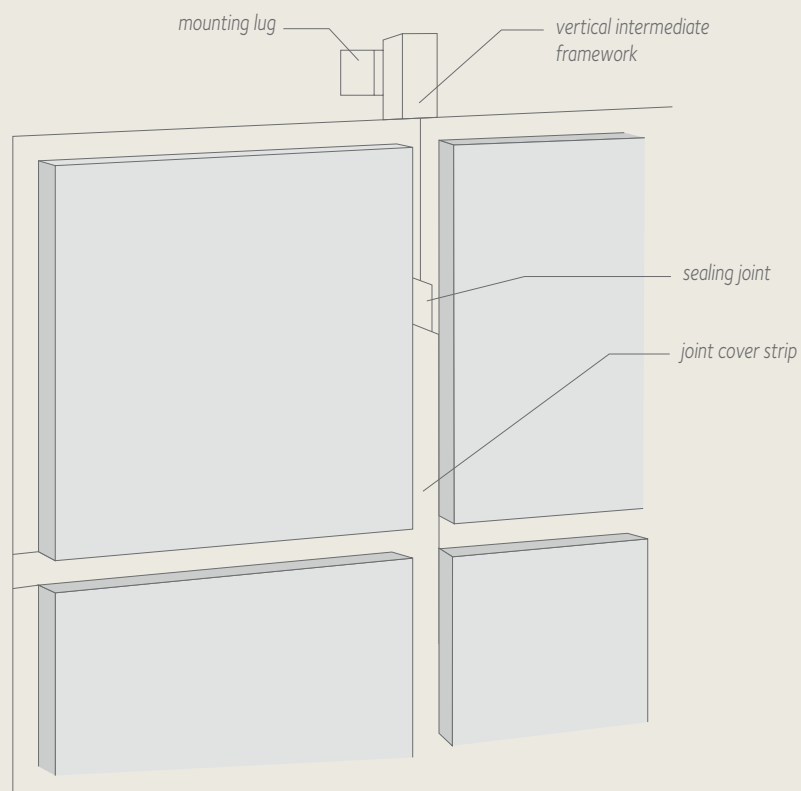
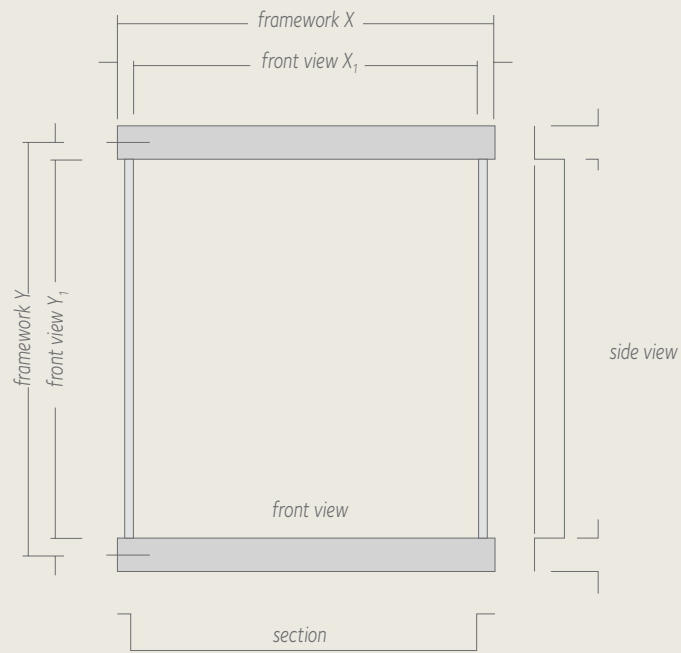



## Credits

Cover: Tom D'Haenens, Philippe Vandenameele

- p. 5: Philippe Vandenameele
- p. 7: "Heysel" metro station, Brussels (Belgium),  
artist Jean-François Octave
- p. 13: University of Pavia (Italy) – architect Giancarlo De Carlo
- p. 21: Tom D'Haenens
- p. 31: Jacques Van den Berghe
- p. 37: PolyVision
- p. 43: Tom D'Haenens
- p. 47: PolyVision
- p. 49: PolyVision
- p. 55: PolyVision

## Copyright

*All rights reserved. No part of this publication may be reproduced in any form or by any means whatsoever, without prior permission from ArcelorMittal.*

*Care has been taken to ensure that the information in this publication is accurate, but ArcelorMittal and any other ArcelorMittal Group company do not accept responsibility or liability for any errors or any information that is found to be misleading.*

*As this document may be subject to change, please consult the latest information in the "Magazines and Brochures" section at [www.arcelormittal.com/fce](http://www.arcelormittal.com/fce)*

ArcelorMittal Flat Carbon Europe

19, avenue de la Liberté  
L-2930 Luxembourg

[fce.technical.assistance@arcelormittal.com](mailto:fce.technical.assistance@arcelormittal.com)  
[www.arcelormittal.com/fce](http://www.arcelormittal.com/fce)