

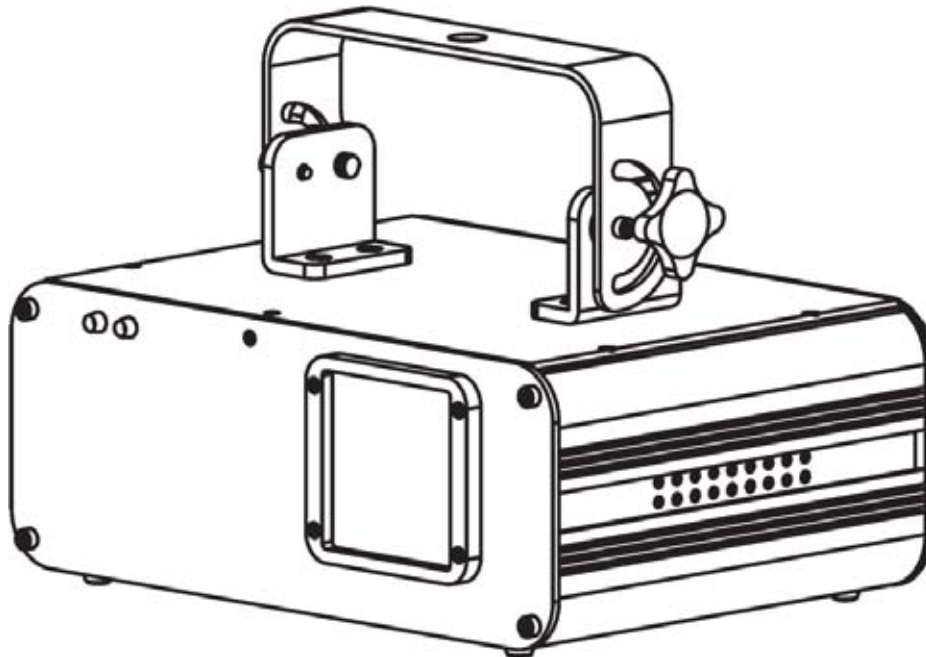

## *User Manual*



LASER LIGHT  
AVOID DIRECT EYE EXPOSURE  
CLASS IIIa LASER PRODUCT  
CLASSIFIED PER 21 CFR 1040.10 & .11  
Complies with US FDA CDRH laser safety  
standards 21 CFR 1040.10 & 1040.11



## Contact Information

### World Headquarters

CHAUVET®

#### General Information

Address: 5200 NW 108th Avenue  
Sunrise, FL 33351  
Voice: (954) 929-1115  
Fax: (954) 929-5560  
Toll free: (800) 762-1084

#### Technical Support

Voice: (954) 929-1115 (Press 4)  
Fax: (954) 756-8015  
Email: tech@chauvetlighting.com

#### World Wide Web

www.chauvetlighting.com

### United Kingdom & Ireland

CHAUVET® Europe Ltd.

#### General Information

Address: Unit 1C  
Brookhill Road Industrial Estate  
Pinxton, Nottingham, UK  
NG16 6NT  
Voice: +44 (0)1773 511115  
Fax: +44 (0)1773 511110

#### Technical Support

Email: uktech@chauvetlighting.com

#### World Wide Web

www.chauvetlighting.co.uk

## Document Information

The information and specifications contained in this document are subject to change without notice. CHAUVET® assumes no responsibility or liability for any errors or omissions that may appear in this manual.

© Copyright 2011 CHAUVET®. All rights reserved

Printed in P.R.C.

Electronically published by CHAUVET® in the United States of America

Author	Editor	Specialist	Manager
A. Diaz	B. Pillow	R. Jones	A. Reiss

## Product at a Glance

Use on Dimmer	⊘	Auto Programs	✓
Outdoor Use	⊘	Auto-ranging Power Supply	✓
Sound Activated	✓	Replaceable Fuse	✓
DMX	✓	User Serviceable	⊘
Master/Slave	✓	Duty Cycle	⊘

---

# TABLE OF CONTENTS

<b>1. Before You Begin .....</b>	<b>4</b>
What is Included .....	4
Unpacking Instructions .....	4
Text Conventions .....	4
Icons .....	4
Safety Notes .....	5
Non Interlocked Housing Warning .....	6
Laser Safety Notes .....	6
Laser Safety Labels .....	7
Laser Emission Data .....	8
Scorpion™ GVC .....	8
Scorpion™ RVM .....	8
Scorpion™ RGY .....	8
<b>2. Introduction .....</b>	<b>9</b>
Product Overview .....	9
Product Dimensions .....	10
<b>3. Setup .....</b>	<b>11</b>
AC Power .....	11
Power Linking .....	11
Mounting .....	12
Orientation .....	12
Rigging .....	12
Proper Usage .....	13
<b>4. Operation .....</b>	<b>14</b>
Control Panel Operation .....	14
Menu Branches .....	14
Changing Options on the Current Menu Branch .....	14
Changing Options on a Different Menu Branch .....	14
Menu Options .....	15
Configuration .....	16
DMX Mode .....	16
Standalone Modes .....	16
Reverse Motion .....	17
Master/Slave Mode .....	18
DMX Channel Assignments and Values .....	19
DMX Ch.2 Pattern Selection .....	20
<b>5. Technical Information .....</b>	<b>21</b>
Product Maintenance .....	21
General Troubleshooting .....	22
Returns Procedure .....	23
Claims .....	23
Contact Information .....	23
DMX Primer .....	24
Starting Address .....	24
Product Linking (Daisy Chain) .....	24
DMX Cabling .....	25
<b>6. Technical Specifications .....</b>	<b>26</b>

---

# 1. BEFORE YOU BEGIN

## What is Included

- 1 x Scorpion™ GVC, RVM, or RGY
- 1 x Power Cord
- 1 x Warranty Card
- 1 x User Manual

## Unpacking Instructions



Immediately upon receiving this product, carefully unpack it and check the container in which you received it. Make sure that you have received all the parts indicated above and that they are all in good condition. If the material inside the container (this product and any other accessory included with it) appears damaged from shipping, or if the container shows signs of mishandling, notify the shipper immediately. In addition, retain the container and all the packing material for inspection.

See the *Claims* section in the “*Technical Information*” chapter.

## Text Conventions

Convention	Meaning
<Menu>	A key to be pressed on the product's control panel
1~512	A range of values
50/60	A set of values of which only one can be chosen
<b>Settings</b>	A menu option not to be modified (for example, showing the operating mode/current status)
<b>Menu &gt; Settings</b>	A sequence of menu options to be followed
ON	A value to be entered or selected

## Icons

Icon	Meaning
	This paragraph contains critical installation, configuration, or operation information. Failure to comply with this information may render the product partially or completely inoperative, cause damage to the product, or cause harm to the user.
	This paragraph contains important installation or configuration information. Failure to comply with this information may prevent the product from functioning correctly.
	This paragraph reminds you of useful, although not critical, information.

---

## Safety Notes



**CAUTION! The use of optical instruments with this product will increase eye hazard.**



**Please read the following notes carefully because they include important safety information about the installation, usage, and maintenance of this product.**

- Keep this User Manual for future consultation. If you sell this product to another user, be sure that they also receive this document.
- Always make sure that the voltage of the outlet to which you are connecting this product is within the range stated on the decal or rear panel of the product.
- This product is for indoor use only! To prevent risk of fire or shock, do not expose this product to rain or moisture.
- Make sure there are no flammable materials close to the unit while operating.
- Always install this product in a location with adequate ventilation, at least 20 in (50 cm) from adjacent surfaces. Be sure that no ventilation slots are blocked.
- Always disconnect this product from the power source before cleaning it or replacing fuse.
- Make sure to replace the fuse with another of the same type and rating.
- If mounting it overhead, always secure this product to a fastening device using a safety chain.
- The maximum ambient temperature ( $T_a$ ) is 104° F (40° C). Do not operate this product at higher temperatures.
- In the event of a serious operating problem, stop using the unit immediately. Never try to repair the unit. Repairs carried out by unskilled people can lead to damage or malfunction. Please contact the nearest authorized technical assistance center.
- Never connect this product to a dimmer pack.
- Make sure the power cord is not crimped or damaged.
- Never disconnect the power cord by pulling or tugging on the cord.
- Never carry a product from the power cord or any moving part. Always use the hanging/mounting bracket or the handles.
- Always avoid direct eye exposure to the light source when this product is on.
- Lasers can be hazardous and have unique safety considerations. Permanent eye injury and blindness is possible if lasers are used incorrectly. Pay close attention to each safety REMARK and WARNING statement in this user manual. Read all instructions carefully BEFORE operating this device.



- **Avoid direct eye contact with laser light. Never intentionally expose your eyes or others to direct laser light.**
- **This laser product can potentially cause instant eye injury or blindness if laser light directly strikes the eyes.**
- **It is illegal and dangerous to shine this laser into audience areas, where the audience or other personnel could get direct laser beams or bright reflections into their eyes.**
- **It is a US Federal offense to shine any laser at aircraft.**
- **Use of controls or adjustments or performance of procedures other than those specified herein may result in hazardous radiation exposure.**
- **There are no user serviceable parts inside the unit. Do not open the housing or attempt any repairs yourself. In the unlikely event your unit may require service, please contact the dealer nearest to you.**

---

## Non Interlocked Housing Warning

- This unit contains high power laser devices internally.
- Do not open the laser housing, due to potential exposure to unsafe levels of laser radiation.
- The laser power levels, accessible if the unit is opened, can cause instant blindness, skin burns, and fires.

## Laser Safety Notes



### **STOP AND READ ALL THE LASER SAFETY NOTES BELOW**

Laser Light is different from any other light sources with which you may be familiar. The light from this product can potentially cause eye injury if not set up and used properly. Laser light is thousands of times more concentrated than light from any other kind of light source. This concentration of light can cause instant eye injuries, primarily by burning the retina (the light sensitive portion at the back of the eye). Even if you cannot feel “heat” from a laser beam, it can still potentially injure or blind you or your audience. Even very small amounts of laser light are potentially hazardous even at long distances. Laser eye injuries can happen quicker than you can blink.

It is incorrect to think that because these laser entertainment products use high speed scanned laser beams, that an individual laser beam is safe for eye exposure.

It is also incorrect to assume that because the laser light is moving, it is safe. This is not true. Nor, do the laser beams always move. Since eye injuries can occur instantly, it is critical to prevent the possibility of any direct eye exposure. In the laser safety regulation, it is not legal to aim Class IIIa lasers in areas where people can be exposed. This is true even if it is aimed below people’s faces, such as on a dance floor.



- **Do not operate the laser without first reading and understanding all safety and technical data in this manual.**
- **Always set up and install all laser effects so that all laser light is at least 3 meters (9.8 feet) above the floor on which people can stand. See the “Proper Usage” section later in this manual.**
- **After set up, and prior to public use, test the laser to ensure proper function. Do not use if any defect is detected.**
- **Laser Light - Avoid Direct Eye Exposure.**
- **Do not point lasers at people or animals.**
- **Never look into the laser aperture or laser beams.**
- **Do not point lasers in areas where people can potentially be exposed, such as uncontrolled balconies, etc.**
- **Do not point lasers at highly reflective surfaces, such as windows, mirrors and shiny metal. Even laser reflections can be hazardous.**
- **Never point a laser at aircraft, as this is a US Federal offense.**
- **Never point un-terminated laser beams into the sky.**
- **Do not expose the output optic (aperture) to cleaning chemicals.**
- **Do not use laser if the laser appears to be emitting only one or two beams.**
- **Do not use the laser if the housing is damaged, open, or if the optics appear damaged in any way.**
- **Never open the laser housing. The high laser power levels inside of the protective housing can start fires, burn skin and will cause instant eye injury.**
- **Never leave this device running unattended.**
- **The operation of a Class IIIa laser show is only allowed if the show is controlled by a skilled and well-trained operator, familiar with the data included in this manual.**
- **The legal requirements for using laser entertainment products vary from country to country. The user is responsible for the legal requirements at the location/country of use.**
- **Always use appropriate lighting safety cables when hanging lights and effects overhead.**

# Laser Safety Labels

<p><b>LASER LIGHT</b>  <b>AVOID DIRECT EYE EXPOSURE</b>  <b>CLASS IIIa LASER PRODUCT</b>          &lt;5 mW, 532 nm &amp; 405 nm, 300 mSec - CW</p> <p>CLASSIFIED PER 21 CFR 1040.10 &amp; .11</p>		CHAUVET Lighting 5200 NW 108th Avenue Sunrise, FL 33351
Complies with US FDA CDRH laser safety standards 21 CFR 1040.10 & 1040.11.		
PRODUCT NAME: Scorpion GVC™ ITEM CODE: 10060263 POWER LINKING: (14 units @ 100-125 V) (28 units @ 220-240 V) LIGHT SOURCE: LASER ORIGIN: MADE IN P.R.C. MANUFACTURING DATE:	THIS APPLIANCE MUST BE GROUNDED USE ONLY FUSE OF SAME TYPE & RATING NOT FOR RESIDENTIAL USE IMPROPRE A L'USAGE DOMESTIQUE FOR INDOOR USE ONLY EMPLACEMENTS SECS DISCONNECT POWER BEFORE SERVICING	
USA/ CANADA Power: AC 100-125 V, 60 Hz, 22 W	WORLDWIDE Power: AC 100-240 V, 50/60 Hz, 22 W	

**NOTICE**

Scorpion™ GVC sticker shown.

The sticker on your unit will reflect the actual Scorpion™ product model, whether GVC, RGY, or RVM.

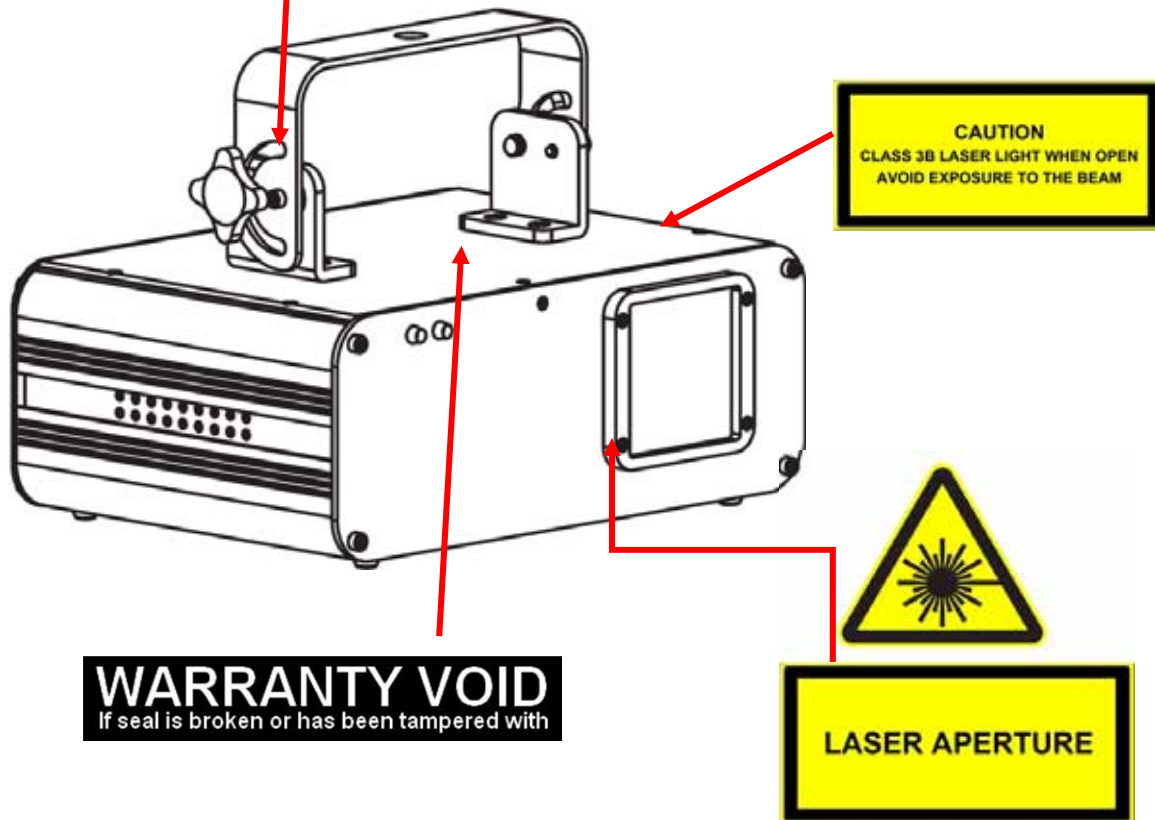

---

## Laser Emission Data



LASER EXPOSURE WARNING



Laser light - Avoid direct eye contact!

Further guidelines and safety programs for safe use of lasers can be found in the ANSI Z136.1 Standard "For Safe Use of Lasers", available from the Laser Institute of America: [www.laserinstitute.org](http://www.laserinstitute.org). Many local governments, corporations, agencies, military and others, require all lasers to be used under the guidelines of ANSI Z136.1. Laser Display guidance can be obtained via the International Laser Display Association: [www.laserist.org](http://www.laserist.org).

### Scorpion™ GVC

Laser Classification	Class IIIa
Green Laser Medium	DPSS Nd: YVO4, 532 nm
Violet Laser Medium	405 nm, GaN
Beam Diameter	<15 mm at aperture
Pulse Data	All pulses < 4 Hz (>0.25 sec)
Divergence (each beam)	<2 mrad
Laser Power for Classification via 7 mm aperture*	<5 mW

### Scorpion™ RVM

Laser Classification	Class IIIa
Red Laser Medium	GaAlAs, 650nm
Violet Laser Medium	405 nm, GaN
Beam Diameter	<15 mm at aperture
Pulse Data	All pulses < 4 Hz (>0.25 sec)
Divergence (each beam)	<2 mrad
Laser Power for Classification via 7 mm aperture*	<5 mW

### Scorpion™ RGY

Laser Classification	Class IIIa
Red Laser Medium	GaAlAs, 650nm
Green Laser Medium	532 nm, DPSS Nd: YV04
Beam Diameter	<15 mm at aperture
Pulse Data	All pulses < 4 Hz (>0.25 sec)
Divergence (each beam)	<2 mrad
Laser Power for Classification via 7 mm aperture*	<5 mW

\*As measured under IEC measurement conditions for classification.

### Laser Compliance Statement

This laser product complies with US FDA CDRH Laser Safety Standards 21 CFR 1040.10 and 1040.11. This laser device is Classified IIIa. (Class 3R is the international equivalent of US Class IIIa). No maintenance is required to keep this product in compliance with laser performance standards.



## 2. INTRODUCTION

### Product Overview

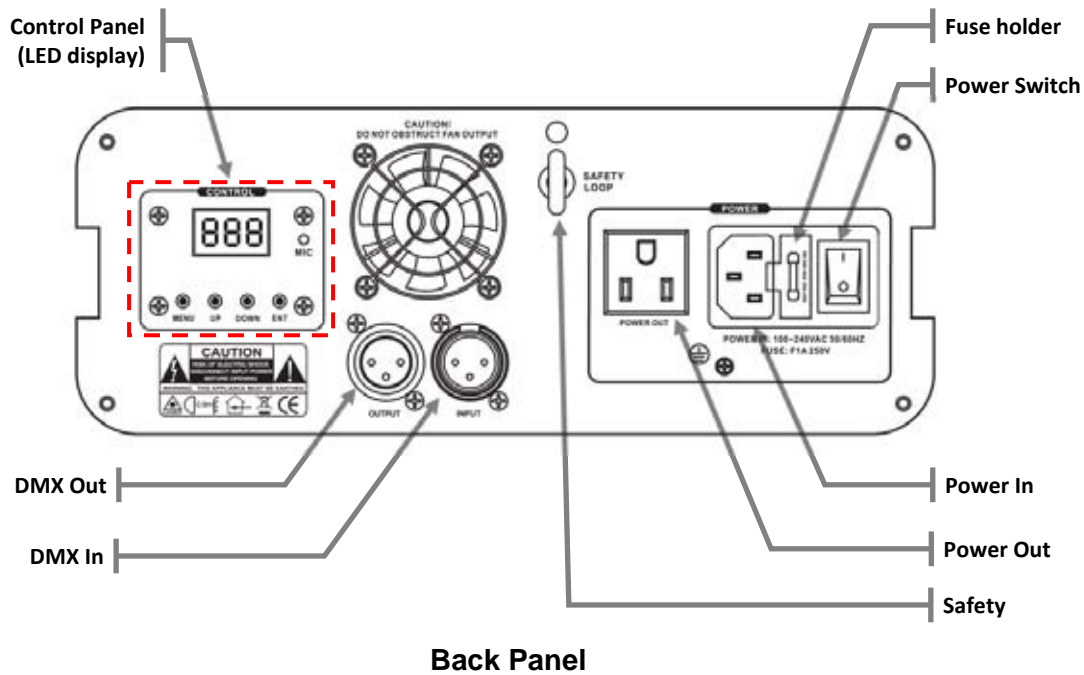

# Product Dimensions

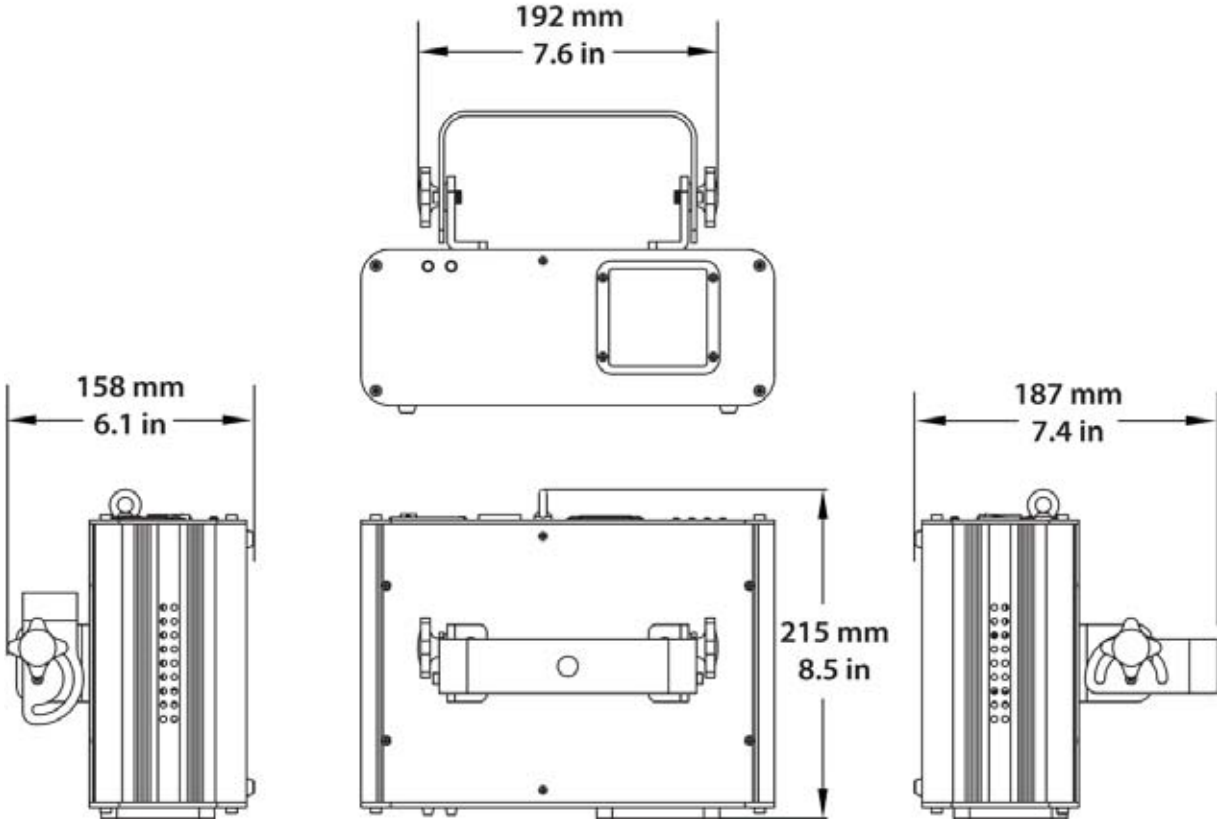

# 3. SETUP

## AC Power

This product has an auto-ranging power supply and can work with an input voltage range of 100~240 VAC, 50/60 Hz.

To determine the power requirements for a particular product, see the label affixed to the back plate of the product or refer to the product's specifications chart. A product's listed current rating indicates its average current draw under normal conditions.



**Always connect this product to a protected circuit (circuit breaker or fuse). Make sure that it has an appropriate electrical ground to avoid the risk of electrocution or fire.**



**Never connect this product to a rheostat (variable resistor) or dimmer circuit, even if the rheostat or dimmer channel serves only as a 0 to 100% switch.**

### Power Linking

This product provides power linking via the Edison outlet located in the back of the unit. Please see the diagram below for further explanation.

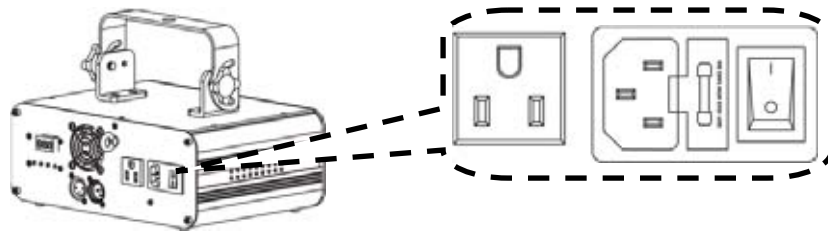

Power Linking Diagram

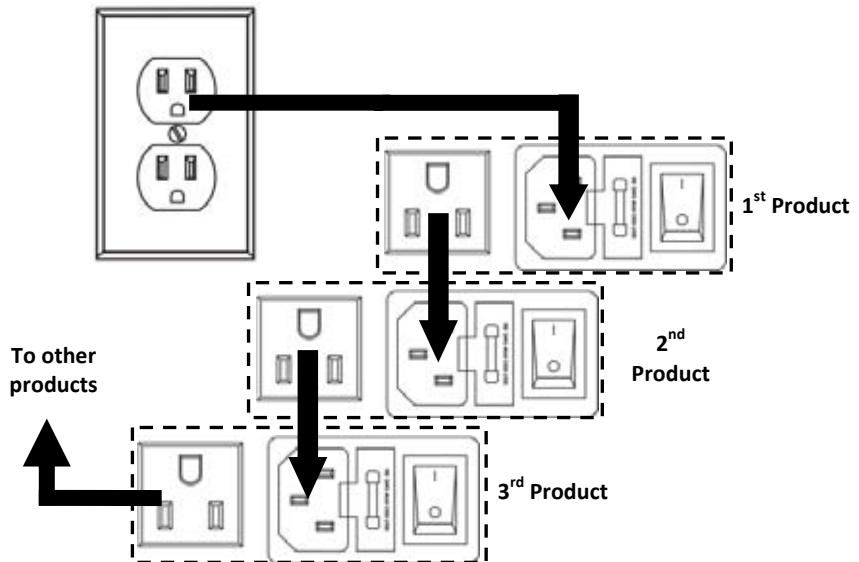

**You can power link up to 14 Scorpion™ GVC/RVM/RGY products on 120 VAC or up to 28 Scorpion™ GVC/RVM/RGY products on 230 VAC.**



**The power linking diagram shown above corresponds to the North American version of this product ONLY! If using this product in other markets, you must consult with the local CHAUVET® distributor, as power linking connectors and requirements may differ in your country or region.**

---

## Mounting

### Orientation

The Scorpion™ GVC/RVM/RGY units may be mounted in any position, provided there is adequate room for ventilation.

### Rigging

Be sure that the structure onto which you are mounting this product can support its weight. Please see the “Technical Specifications” section of this manual for weight information.

Mount the product securely. You can do this with a screw, a nut, and a bolt. You could also use a mounting clamp if rigging this product onto a truss. The bracket has a hole 13 mm in diameter, which is appropriate for this purpose.

When mounting this product overhead, always use a safety cable.

Always consider ease of access to the unit for maintenance and programming purposes before deciding on a location for this product

When power linking multiple products, always consider the length of the power linking cable and mount the products close enough from each other to accommodate for this.

The bracket knobs allow for directional adjustment when aiming the product to the desired angle. Do not use tools to loosen or tighten the bracket knobs. Doing otherwise could damage the knobs.

Mounting Diagram

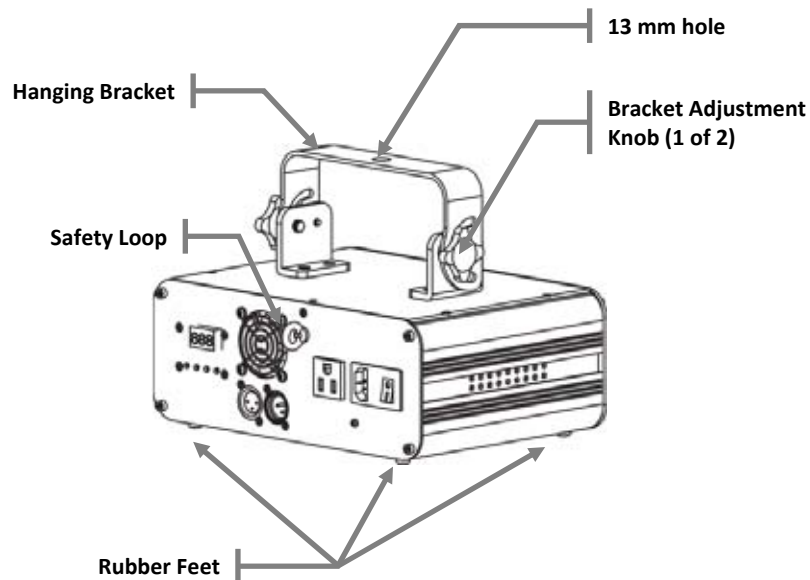

---

## Proper Usage

This product is for overhead mounting only. For safety purposes, CHAUVET® recommends mounting your lighting effect products on steady elevated platforms or sturdy overhead supports using suitable hanging clamps. In all cases, you must use safety cables. You can obtain appropriate mounting hardware from your lighting vendor.

International laser safety regulations require that laser products must be operated in the fashion illustrated below, with a minimum of 3 meters (9.8 ft) of vertical separation between the floor and the lowest laser light vertically. Additionally, 3 meters of horizontal separation is required between laser light and audience or other public spaces.

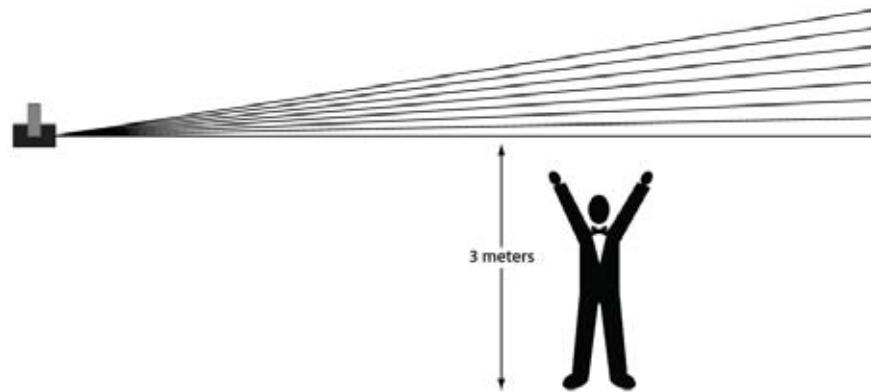

**CAUTION: USE OF CONTROLS OR ADJUSTMENTS OR PERFORMANCE OF PROCEDURES OTHER THAN THOSE SPECIFIED HEREIN MAY RESULT IN HAZARDOUS RADIATION EXPOSURE.**

## 4. OPERATION

### Control Panel Operation

To access the control panel functions, use the four buttons located underneath the display.

Button	Function
<MENU>	Press to find an operation mode or to back out of the current menu option
<DOWN>	Press to scroll down the list of options or to find a lower value
<UP>	Press to scroll up the list of options or to find a higher value
<ENT>	Press to activate a menu option or a selected value



### Menu Branches

The menu structure of the Scorpion™ GVC/RVM/RGY products has seven branches, as follows:

- Auto/Sound (13 option)
- Laser Sky Color (4 options)
- Laser Sky Effect (1 option)
- Sound Sensitivity (10 options)
- DMX address (503 options)
- Slave (1 option)
- Reverse (2 options with two values each)
- **The control panel will remember the last setting you programmed, even after you have turned the product off.**
- **In addition, the control panel will remember the last selected option from each menu branch.**



### Changing Options on the Current Menu Branch

To change an option on the same menu branch, do the following:

1. Press <MENU> once (the LED display will blink).
2. Press <UP> or <DOWN> until the desired menu option shows on the LED display.
3. Press <ENT> to accept the new option (the new option will show solid on the LED display).

### Changing Options on a Different Menu Branch

To change an option on a different menu branch, you must exit the current branch.

1. Press <MENU> once (the LED display will blink).
2. Press <MENU> repeatedly until seeing the active option of the desired menu branch.
3. Press <UP> or <DOWN> until the desired menu option within the new menu branch shows on the LED display.
4. Press <ENT> to accept the new option (the new option will show solid on the LED display).

## Menu Options

The menu below refers to three different CMY products, GVC, RVM, and RGY, each with a different set of colors.



Model	Color 1	Color 2	Color 3
GVC	Green	Violet	Cyan
RVM	Red	Violet	Magenta
RGY	Red	Green	Yellow

Branch	Programming Steps	Description	
Auto/Sound	AF1	Fast program shows color 1	
	AS1	Slow program shows color 1	
	AF2	Fast program shows color 2	
	AS2	Slow program shows color 2	
	AF3	Fast program shows color 3	
	AS3	Slow program shows color 3	
	AFM	Fast program alternates colors 1 through 3	
	ASM	Slow program alternates colors 1 through 3	
	So1	Sound activated program shows color 1	
	So2	Sound activated program shows color 2	
	So3	Sound activated program shows color 3	
Laser Sky Color	SoM	Sound activated program alternates colors 1 through 3	
	rdM	Randomly selects an operation mode	
	LS1	Laser sky effect shows the product's first color	
	LS2	Laser sky effect shows the product's second color	
Laser Sky Effect	LS3	Laser sky effect shows the product's third color	
	LSS	Sound triggered laser sky effect alternates colors	
Sound sensitivity	LSU	Laser sky effect position setting	
DMX	S 0-S 9	Adjusts the internal microphone's sensitivity	
Slave	001-503	Selects the DMX starting address (1-503)	
Reverse	SLA	SLA	Sets the product as "Slave" for master/slave operation
		rEv	P-y/P-n
		t-y/t-n	Reverses tilt movement direction

---

## Configuration

### DMX Mode

Setting this product to operate in DMX mode will allow you to control it with a DMX controller.

1. Connect this product to a suitable power outlet.
2. Turn this product on.
3. Connect a DMX cable from the DMX output of the DMX controller to the DMX input socket of this product.

### Starting Address

When selecting a starting DMX address, you must always consider the number of DMX channels assigned to the selected DMX mode. If you choose a starting address that is too high, you could restrict the access to some of the channels of the DMX mode in use.

The Scorpion™ GVC/RVM/RGY products use **ten** DMX channels, which defines the highest configurable address to **503**.

If you are not familiar with the DMX protocol, you may refer to the “DMX Primer” section in the “*Technical Information*” chapter.

To select the starting address, do the following:

1. Press **<MENU>** repeatedly until the current starting address (**001 to 503**) shows blinking on the display.
2. Use **<UP>** or **<DOWN>** to select a different starting address (**001~503**).
3. Press **<ENT>** (the new starting address will show solid on the display).

### Standalone Modes



**Never connect a product that is operating in any standalone mode, whether Static, Automatic, or Sound to a DMX string connected to a DMX controller. This is because products in standalone mode may transmit DMX signals that could interfere with the DMX signals from the controller.**

Setting this product to operate in DMX mode will allow you to control it without a DMX controller.

1. Connect this product to a suitable power outlet.
2. Turn this product on.

### Sound Mode

To enable the Sound mode, do the following:

1. Press **<MENU>** repeatedly until the active option of the Auto/Sound branch (**AF1 to rdM**) appears on the display.
2. Use **<UP>** or **<DOWN>** to select a sound triggered program (**So1~SoM**).
3. Press **<ENT>** (the new sound program will show solid on the display).
4. Turn the music on.
5. Press **<MENU>** repeatedly until the active option of the Sound Sensitivity branch (**S 0 to S 9**) shows blinking on the display.
6. Use **<UP>** or **<DOWN>** to select the sensitivity level (**S 0~S 9**).
7. Press **<ENT>** (the new sound sensitivity will show solid on the display).



**The product will only respond to the low frequencies of the music (bass and drums).**



---

## Automatic Mode

To enable the Automatic mode, follow the instructions below:

1. Press **<MENU>** repeatedly until the active option of the Auto/Sound branch (**AF1** to **rdM**) shows blinking on the display.
2. Use **<UP>** or **<DOWN>** to select an automatic program (**AF1~ASM**).
3. Press **<ENT>** (the new auto program will show solid on the display).

## Laser Sky Color Mode

To enable the Laser Sky Color mode, follow the instructions below:

1. Press **<MENU>** repeatedly until the active option of the Laser Sky Color branch (**LS1** to **LSS**) shows blinking on the display.
2. Use **<UP>** or **<DOWN>** to select a laser sky color option (**LS1~LSS**).
3. Press **<ENT>** (the new laser sky color will show solid on the display).

## Laser Sky Effect Mode

To enable the Laser Sky Effect mode, follow the instructions below:

1. Press **<MENU>** repeatedly until **LSU** shows blinking on the display.
2. Use **<UP>** or **<DOWN>** to change the angle of the laser sky effect.
3. Press **<ENT>** (**LSU** will show solid on the display).

## Reverse Motion

To reverse the direction of the pan and tilt motion, follow the instructions below:

1. Press **<MENU>** repeatedly until **rEv** shows blinking on the display.
2. Press **<ENT>** (the current option for pan direction will show (**P-n** or **P-Y**)).
  - a) To change the setting, use **<UP>** or **<DOWN>** and continue to step "3".
  - b) To keep the setting, continue to step "3".
3. Press **<ENT>** (the current option for tilt direction will show (**t-n** or **t-Y**)).
  - a) To change the setting, use **<UP>** or **<DOWN>** and continue to step "4".
  - b) To keep the setting, continue to step "4".
4. Press **<ENT>** (the current software version will show briefly on the display, followed by **rEv**).

---

## Master/Slave Mode

This mode allows a single Scorpion™ GVC/RVM/RGY product (the “master”) to control the actions of one or more Scorpion™ GVC/RVM/RGY units (the “slaves”) without the need of a DMX controller. The master unit will be set to operate in either Automatic, Sound, or Laser Sky mode, while the slave units will be set to operate in Slave Mode. Once set and connected, the slave units will operate in unison with the master unit.

Configure the units as indicated below.

### Slave units:

1. Press **<MENU>** repeatedly until **SLA** shows blinking on the display.
2. Press **<ENT>** (**SLA** will show solid on the display).
3. Connect the DMX input of the first slave unit to the DMX output of the master unit
4. Connect the DMX input of the subsequent slave units to the DMX output of the previous slave unit.
5. Finish setting and connecting all the slave units.

### Master unit:

1. Set the master unit to operate in either, Automatic, Laser Sky, or Sound mode, as previously indicated.
2. Make the master unit the first unit in the DMX daisy chain.



- **Wait until all the slave units are configured and connected before connecting the master unit to the DMX daisy chain.**
- **Never connect a DMX controller to a DMX string configured for Master/Slave operation because it may interfere with the signals from the master unit.**















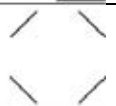









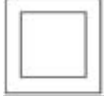



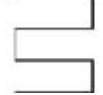

**Do not connect more than 31 slave units to the master unit.**

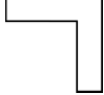
## DMX Channel Assignments and Values

Channel	Function	Value	Setting
1	<b>Control Mode</b> <i>(Use channels 2~10 in this mode)</i>	000 ⇔ 017 018 ⇔ 035 036 ⇔ 053 054 ⇔ 071 072 ⇔ 089 090 ⇔ 107 108 ⇔ 125 126 ⇔ 143 144 ⇔ 161 162 ⇔ 179 180 ⇔ 197 198 ⇔ 215 216 ⇔ 233 234 ⇔ 255	Manual Mode Automatic fast color 1 Automatic slow color 1 Automatic fast color 2 Automatic slow color 2 Automatic fast color 3 Automatic slow color 3 Automatic fast mixed colors Automatic slow mixed colors Sound color 1 Sound color 2 Sound color 3 Sound mixed colors Random (Auto)
2	<b>Pattern selection</b> <i>(Only when CH1 is between 000~017)</i>	000 ⇔ 255	32 patterns, as shown in page 20
3	<b>Color selection</b>	000 ⇔ 024 025 ⇔ 049 050 ⇔ 074 075 ⇔ 099 100 ⇔ 124 125 ⇔ 149 150 ⇔ 174 175 ⇔ 199 200 ⇔ 224 225 ⇔ 255	Blackout Preprogrammed Color Color 1 Color 2 Color 3 Alternate Color 1/2 Alternate Color 2/3 Alternate Color 1/3 Alternate Color 1/2/3 Color Roll
4	<b>Color Changing Speed</b>	000 ⇔ 004 005 ⇔ 255	Stop Slow ⇔ fast
5	<b>Zoom</b>	000 ⇔ 127 128 ⇔ 169 170 ⇔ 209 210 ⇔ 255	100%~5% Zoom In Macro Zoom Out Macro Zoom In and Out Macro
6	<b>X-Axis Move (Pan)</b>	000 ⇔ 127 128 ⇔ 191 192 ⇔ 255	128 different positions on Y-Axis Move Left to right to Left (slow ⇔ fast) Move Left to right to Left (fast ⇔ slow)
7	<b>Y-Axis Move (Tilt)</b>	000 ⇔ 127 128 ⇔ 191 192 ⇔ 255	128 different positions on X-Axis Move Up to down to Up (slow ⇔ fast) Move Up to down to Up (fast ⇔ slow)
8	<b>X-Axis Roll</b>	000 ⇔ 127 128 ⇔ 191 192 ⇔ 255	Y-Axis Roll Roll (slow ⇔ fast) Roll (fast ⇔ slow)
9	<b>Y-Axis Roll</b>	000 ⇔ 127 128 ⇔ 191 192 ⇔ 255	Y-Axis Roll Roll (slow ⇔ fast) Roll (fast ⇔ slow)
10	<b>Rotate</b>	000 ⇔ 127 128 ⇔ 191 192 ⇔ 255	Z-Axis Roll Clockwise Rotate Counterclockwise Rotate

## DMX Ch.2 Pattern Selection

DMX VALUE	PATTERN	DMX VALUE	PATTERN	DMX VALUE	PATTERN
000~007		096~103		190~197	
008~015		104~111		198~205	
016~023		112~119		206~213	
024~031		120~127		214~221	
032~039		128~135		222~229	
040~047		136~143		230~237	
048~055		144~151		238~245	
056~063		152~159		246~255	
064~071		160~167			
072~079		168~175			
080~087		176~181			
088~095		182~189			

---

# 5. TECHNICAL INFORMATION

## Product Maintenance

Dust build up reduces light output performance and can cause overheating. This can lead to reduction of the light source's life and mechanical wear. To maintain optimum performance and minimize wear, you should clean your lighting products at least twice a month. However, be aware that usage and environmental conditions could be contributing factors to increase the cleaning frequency.

To clean this lighting product, follow the instructions below:

- Unplug the product from power.
- Wait until the product is cold.
- Use a vacuum (or dry compressed air) and a soft brush to remove dust collected on the external surface and fan vents.
- Clean the glass panel (laser aperture) with a mild solution of glass cleaner or isopropyl alcohol.
- Apply the solution directly to a soft, lint-free cotton cloth or a lens cleaning tissue, and drag any dirt or grime to the outside of the glass.
- Gently polish the glass surface until it is free of haze and lint.



**Always dry the glass surface carefully after cleaning them.**



- **Refrain from spinning the fan using compressed air because you could damage it.**
- **DO NOT open this product for cleaning or servicing.**

## General Troubleshooting

Symptom	Possible Cause	Possible Action
Circuit breaker or fuse keeps blowing	<ul style="list-style-type: none"> <li>Excessive load on the circuit</li> </ul>	<ul style="list-style-type: none"> <li>Make sure that the total load does not exceed 80% of the breaker or fuse nominal current</li> </ul>
	<ul style="list-style-type: none"> <li>Short circuit along the power lines</li> </ul>	<ul style="list-style-type: none"> <li>Check the power lines and power cords</li> </ul>
Product does not power up	<ul style="list-style-type: none"> <li>No energy on power outlet</li> </ul>	<ul style="list-style-type: none"> <li>Check power outlet</li> <li>Change to another outlet</li> </ul>
	<ul style="list-style-type: none"> <li>Loose or damaged power cord</li> </ul>	<ul style="list-style-type: none"> <li>Check the power cord</li> </ul>
	<ul style="list-style-type: none"> <li>Blown fuse</li> </ul>	<ul style="list-style-type: none"> <li>Replace blown fuse with a good one of the same type and rating</li> </ul>
	<ul style="list-style-type: none"> <li>Internal problem</li> </ul>	<ul style="list-style-type: none"> <li>Send product for repair</li> </ul>
Product does not respond to DMX	<ul style="list-style-type: none"> <li>Wrong starting address on the product</li> </ul>	<ul style="list-style-type: none"> <li>Set the correct starting address on the product</li> <li>Use the right fader(s) on the controller</li> </ul>
	<ul style="list-style-type: none"> <li>Wrong DMX personality on the product</li> </ul>	<ul style="list-style-type: none"> <li>Set the correct DMX product's personality</li> <li>Assign the faders accordingly</li> </ul>
	<ul style="list-style-type: none"> <li>Wrong polarity setting on the DMX controller</li> </ul>	<ul style="list-style-type: none"> <li>Change the signal polarity on the controller</li> </ul>
	<ul style="list-style-type: none"> <li>Loose or damaged DMX cable</li> </ul>	<ul style="list-style-type: none"> <li>Check the DMX cable before the faulty unit</li> </ul>
	<ul style="list-style-type: none"> <li>Internal problem</li> </ul>	<ul style="list-style-type: none"> <li>Send product for repair</li> </ul>
Intermittent DMX Problems	<ul style="list-style-type: none"> <li>Signal cables are not DMX compatible</li> </ul>	<ul style="list-style-type: none"> <li>Replace non DMX cables with true DMX cables</li> </ul>
	<ul style="list-style-type: none"> <li>Interference with AC or radio signals</li> </ul>	<ul style="list-style-type: none"> <li>Keep DMX cables away from AC wires or radio equipment</li> </ul>
	<ul style="list-style-type: none"> <li>DMX cable too long</li> </ul>	<ul style="list-style-type: none"> <li>Install an optically coupled DMX amplifier right before the product with intermittent problems</li> </ul>
	<ul style="list-style-type: none"> <li>Too many products connected</li> </ul>	<ul style="list-style-type: none"> <li>Install an optically coupled DMX amplifier after unit #32</li> </ul>
	<ul style="list-style-type: none"> <li>Terminator not connected</li> </ul>	<ul style="list-style-type: none"> <li>Install a terminator, as indicated in the "DMX Primer" section.</li> </ul>



If you still experience problems after trying the above solutions, contact CHAUVET® Technical Support.

---

## Returns Procedure

The user must send the merchandise prepaid, in the original box, and with its original packing and accessories. CHAUVET® will not issue call tags.

Call CHAUVET® and request a Return Merchandise Authorization (RMA) number before shipping the product. Be prepared to provide the model number, serial number, and a brief description of the cause for the return.

The user must clearly label the package with a Return Merchandise Authorization (RMA) number. CHAUVET® will refuse any product returned without an RMA number.



**DO NOT write the RMA number directly on the box. Instead, write it on a properly affixed label.**

Once you have received the RMA number, please include the following information on a piece of paper inside the box:

- Your name
- Your address
- Your phone number
- The RMA number
- A brief description of the problem

Be sure to pack the product properly. Any shipping damage resulting from inadequate packaging will be the customer's responsibility. As a suggestion, proper UPS packing or double-boxing is always a safe method to use.



**CHAUVET® reserves the right to use its own discretion to repair or replace returned product(s).**

## Claims

The carrier is responsible for any damage incurred during shipping to this product or any part that shipped with it. Therefore, if the received merchandise appears to have damages caused during shipping, the customer must submit the damage report and any related claims with the carrier, not CHAUVET®. The customer must submit the report upon reception of the damaged merchandise. Failure to do so in a timely manner may invalidate the customer's claim with the carrier.

For other issues such as missing components or parts, damage not related to shipping, or concealed damage, the customer must make claims to CHAUVET® within seven (7) days of receiving the merchandise.

## Contact Information

### World Headquarters

CHAUVET®

#### General Information

Address: 5200 NW 108th Avenue  
Sunrise, FL 33351  
Voice: (954) 929-1115  
Fax: (954) 929-5560  
Toll free: (800) 762-1084

#### Technical Support

Voice: (954) 929-1115 (Press 4)  
Fax: (954) 756-8015  
Email: tech@chauvetlighting.com

#### World Wide Web

[www.chauvetlighting.com](http://www.chauvetlighting.com)

### United Kingdom & Ireland

CHAUVET® Europe Ltd.

#### General Information

Address: Unit 1C  
Brookhill Road Industrial Estate  
Pinxton, Nottingham, UK  
NG16 6NT  
Voice: +44 (0)1773 511115  
Fax: +44 (0)1773 511110

#### Technical Support

Email: uktech@chauvetlighting.com

#### World Wide Web

[www.chauvetlighting.co.uk](http://www.chauvetlighting.co.uk)

---

## DMX Primer

The USITT DMX512-A data transmission protocol (DMX, from now on) is based on the EIA-485 standard and it has 512 channels (001 to 512). This system requires a controller (DMX controller), one or more DMX compatible products, and a DMX circuit (also known as “DMX universe”) to link the products to the controller.

Depending on their complexity and features, DMX compatible products may require from one to more than 30 DMX channels to operate. Some DMX products have multiple operation modes (also known as “personalities”), each with its own number of channels and controllable parameters.

### Starting Address

In the DMX system, the controller sends DMX data to each product based on the product’s starting address. The starting address is the number of the DMX channel (001 to 512) assigned to the product’s first control channel (Channel 1). When assigning starting addresses to multiple products, it is critical to ensure that no starting address is already in use by another product to prevent channels from overlapping. Otherwise, the affected products may operate erratically.

For instance, a user has two DMX compatible products. Product “A” has four channels and product “B” has six channels. If the user configures the starting address of product “A” to “001”, channels 001 through 004 on the DMX controller will control product “A”. This means that the user should assign the starting address of product “B” to “005” or higher. For a starting address of “005”, the DMX controller would use channels 005 to 010 to control product “B”.

It is possible to control multiple products of the same type by assigning each one of them the same starting address. In this case, all the products would respond in unison (synchronized) to the signals from the DMX controller.

### Product Linking (Daisy Chain)

DMX compatible products receive the control signals from the DMX controller through the DMX cables. Each product has a DMX In and a DMX Out connector. The figure to the right illustrates how the products link to each other using multiple segments of DMX cable in a sequential format called “daisy chain”.

The order in which the products connect to the DMX controller is irrelevant because all products receive the same DMX signals and they only respond to them based on their individual starting addresses. However, it is important to notice that the connections between products should always be as short and direct as possible.

To ensure the integrity of the DMX signal, follow the recommendations of the EIA-485 standard:

- The maximum recommended cable length is 500 m (1,640 feet).
- The maximum recommended number of products on the same daisy chain is 32.

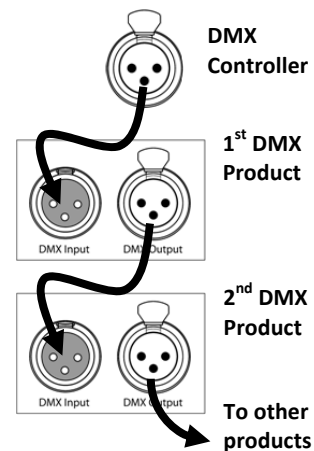

**Connecting more than 32 products on one daisy chain without the use of a DMX optically-isolated splitter may result in deterioration of the digital DMX signal.**



## DMX Cabling

The DMX protocol requires using special data cables to accommodate the high speed digital signals. Despite their apparent similarities, data cables are electrically different from standard microphone cables because they can carry high frequency digital signals and have better protection against electromagnetic interference. You can purchase CHAUVET® certified DMX cables directly from a dealer/distributor or make your own DMX cable.

If you choose to make your own DMX cable, you must use a data-grade cable such as the Belden 9841, which has the following electrical characteristics:

Type:	shielded, 2-conductor twisted pair
Maximum capacitance between conductors:	30 pF/ft
Maximum capacitance between conductor and shield:	55 pF/ft
Maximum resistance:	20 ohms/1000 ft
Nominal impedance:	100~140 ohms

## DMX Connectors

Each DMX cable must have a male XLR connector on one end and a female XLR connector on the other end. The DMX protocol indicates that the XLR connectors must have five pins. However, most lighting products use the 3-pin XLR connector. The pin assignment of the 3-pin and 5-pin XLR connectors in a DMX cable is as follows:

Signal	Male Plug		Female Plug			Signal
	3-Pin	5-Pin	5-Pin	3-Pin		
Common	1	1	1	1	1	Common
Data -	2	2	2	2	2	Data -
Data +	3	3	3	3	3	Data +
Not used		4	4			Not used
Not used		5	5			Not used

You can use the above table to create a 3-pin/3-pin cable, a 5-pin/5-pin cable, or a 3-pin to 5-pin adapter.

The DMX daisy chain uses a terminator to reduce signal transmission problems, especially with long cables. The terminator consists of either a 3-pin or 5-pin XLR male plug with a 120 Ω, ¼ W resistor connected to the wire side of pins 2 and 3, as shown below.

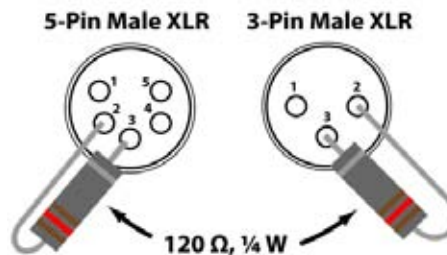

The terminator plug connects to the DMX Out socket of the last DMX product in the daisy chain.



**Do not allow the common wire of the DMX cable to touch the product's chassis ground. This could cause a ground loop, which may affect your products' performance. Test all DMX cables with an ohmmeter to verify the correct polarity of the wires, and to make sure that they are not touching the shield or each other.**

## 6. TECHNICAL SPECIFICATIONS

<b>Dimensions and Weight</b>	<b>Length</b>	<b>Width</b>	<b>Height</b>	<b>Weight</b>
	11 in (276 mm)	8.5 in (215 mm)	7.4 in (187 mm)	5.6 lbs (2.7 kg)

**Note:** Dimensions in inches rounded to the nearest decimal digit

<b>Power</b>	<b>Power Supply Type</b>	<b>Range</b>	<b>Voltage Selection</b>
	Switching (internal)	100~240 V, 50/60 Hz	Auto-ranging

<b>Parameter</b>	<b>120 V, 60 Hz</b>	<b>230 V, 50 Hz</b>
Energy consumption	22 W	22 W
Operating current (units)	0.2 A	0.1 A
Power linking (units)	14 units	28 units
Fuse	T 1 A, 250 V	T 1 A, 250 V

<b>Power I/O</b>	<b>Input</b>	<b>Output</b>
Connectors	IEC	Edison (USA)
Cord plug	Edison (USA)	N/A

### Light Source

<b>Scorpion™ GVC</b>	<b>Type</b>	<b>Power</b>	<b>Wavelength</b>
	Laser (green)	10 mW	532 nm
	Laser (violet)	20 mW	405 nm

<b>Scorpion™ RVM</b>	<b>Type</b>	<b>Power</b>	<b>Wavelength</b>
	Laser (red)	15 mW	650 nm
	Laser (violet)	15 mW	405 nm

<b>Scorpion™ RGY</b>	<b>Type</b>	<b>Power</b>	<b>Wavelength</b>
	Laser (red)	20 mW	650 nm
	Laser (green)	10 mW	532 nm

<b>Photo Optic</b>	<b>Parameter</b>	<b>Value</b>
	Zoom range	1° ~36°
	Pan positioning	48°
	Tilt positioning	39°

<b>Thermal</b>	<b>Maximum External Temp.</b>	<b>Cooling System</b>
	104° F (40° C)	Fan cooled

<b>DMX</b>	<b>I/O Connectors</b>	<b>Connector Type</b>	<b>Channel Range</b>
	3-pin XLR	Sockets	10

<b>Ordering</b>	<b>Scorpion™ GVC</b>	<b>Scorpion™ RVM</b>	<b>Scorpion™ RGY</b>
	10060263	10060265	10060264

