

**GB** Fitting Instructions for Basic Carrier

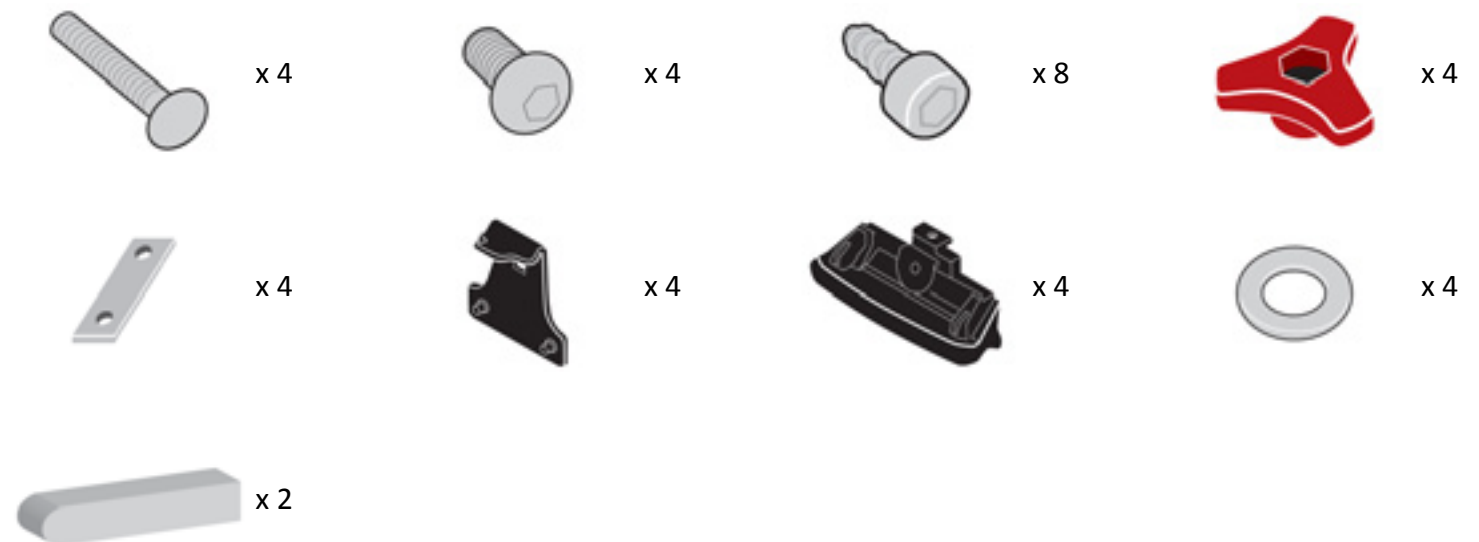

## First Time Installation

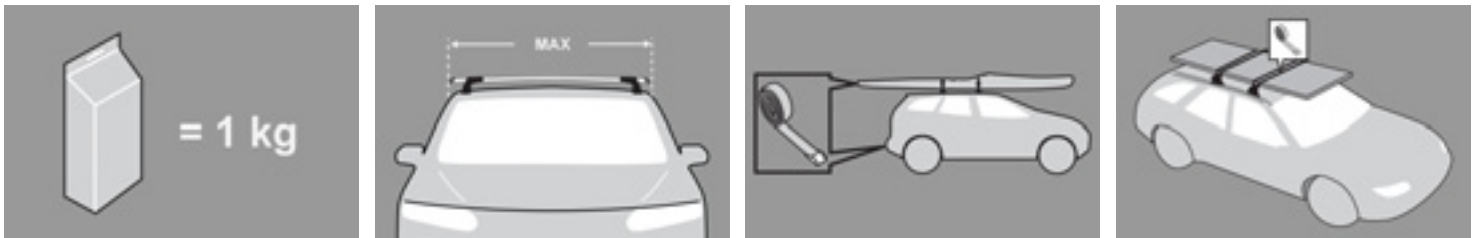

- Remove parts from packaging and check contents. Contact your Prorack dealer if parts are missing or damaged.



- This kit fits type A, B, C and D.
- These instructions show type A crossbar fitted. They also apply to type B, C and D.



- Use keys to remove covers.



- Use hex screwdriver to reverse adjusting screw 10 turns.



- Press adjusting screw and pull crossbar legs out. Refer to the crossbar instructions for crossbar adjustment.
- Ensure each end of the crossbar is adjusted equally.

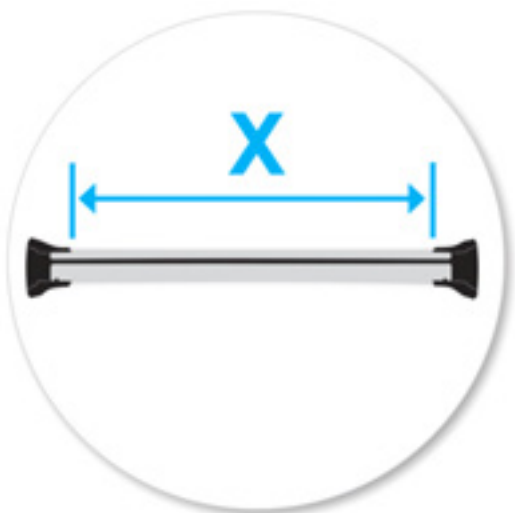

- Set bars to length (refer to the crossbar instructions for crossbar adjustment).
- Please check the rear of this manual for information relating specifically to your vehicle.



- Tighten adjusting screw to 5 Nm.



- Remove clamp block by pressing backwards.



- Remove both pins from each leg (use spanner located inside left hand cover to assist).



- Detach foot from leg. Store loose parts in a safe place.
- Repeat for all legs.



- Select four feet assemblies and match the left and right assemblies to the left and right roof rack legs.
- Assemble foot from kit into leg by pressing it down.
- Ensure foot interlocks with leg.



- Using short cap screw and washer, secure assembly onto leg (use Hex Screwdriver supplied with crossbar to assist)
- Do not over tighten.
- Repeat for all legs.



- NOTE: FRONT CROSSBAR ONLY
- TYPE A CROSSBARS ONLY
- Insert foam into crossbar as shown.
- Trim if required.



- Use two M5 x 12 mm self tapping screws to secure the assembly onto the leg.
- Do not over tighten.

## Fitment



- Locate two holes at each position along the inside of the roof rails.
- Place crossbars approximately above these holes on roof rails.
- Ensure back edge of roof rack sits flush with the back edge of vehicle roof rail.



- Apply protective strip as shown.  
Trim if required.



- Ensure the two pins of the clamp engages correctly with the holes in the roof rail.
- Place one hand on the leg and apply downward pressure.
- Slide clamp through opening in leg.



- Thread the coach bolt through the clamp and the leg.





- Tighten the red plastic knob.
- Ensure the clamp engages correctly on inside of roof rail.
- Ensure the red plastic knob is in the position shown when fully tightened.
- Do not over tighten.
- Repeat for all four positions.



- Use keys to fit and lock covers
- Check crossbar is securely attached to the vehicle.

**CAUTION: Regularly check screws are tight**