

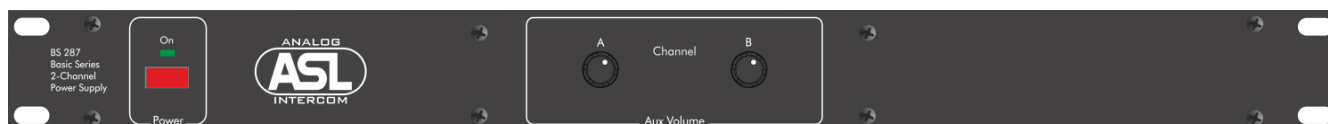

**BS 287**

## **DUAL CHANNEL POWER SUPPLY**



## **USER MANUAL**

May 2013 © ASL Intercom BV

**This products is designed and manufactured by:**

ASL Intercom B.V.  
Zonnebaan 42, 3542 EG Utrecht  
The Netherlands  
Tel: +31 (0)30 2411901  
Fax: +31 (0)30 2667373  
Email: [info@asl-inter.com](mailto:info@asl-inter.com)  
Web: [www.asl-inter.com](http://www.asl-inter.com)

## CONTENT OF THIS USER MANUAL

|      |  |   |
|------|--|---|
| 1.0  | SAFETY INSTRUCTIONS .....              | 3 |
| 2.0  | UNPACKING .....                        | 4 |
| 3.0  | WARRANTY .....                         | 4 |
| 4.0  | MECHANICAL INSTALLATION.....           | 4 |
| 5.0  | MAINS POWER & SAFETY EARTH .....       | 4 |
| 6.0  | GENERAL DESCRIPTION.....               | 4 |
| 7.0  | FRONT PANEL CONTROLS & CONNECTOR ..... | 5 |
| 8.0  | REAR PANEL CONTROLS & CONNECTORS ..... | 5 |
| 9.0  | TECHNICAL SPECIFICATIONS .....         | 5 |
| 10.0 | PARTY LINE, TECHNICAL CONCEPT .....    | 6 |
| 11.0 | CABLING .....                          | 6 |
| 12.0 | EARTHING CONCEPT .....                 | 7 |
| 13.0 | BS 287 BLOCK DIAGRAM.....              | 7 |
| 14.0 | POSSIBLE SYSTEM CONFIGURATION .....    | 8 |

## 1.0 SAFETY INSTRUCTIONS

**Please always follow these instructions to help ensure against injury to yourself and/or damage to the system**

1. Read all safety and operating instructions before you operate the apparatus.
2. Retain all safety and operating instructions for future reference.
3. Heed all warnings on the apparatus and in the safety and operating instructions and follow all installation and use instructions.
4. Follow all installation, operating and use instructions.
5. Unplug the apparatus from the AC power outlet before cleaning. Use only a damp cloth for cleaning the exterior of the apparatus.
6. Do not use accessories or attachments not recommended by the manufacturer, as they may cause hazards and void the warranty.
7. Do not operate this apparatus in high humidity areas or expose it to water or moisture.
8. Do not place the apparatus on an unstable cart, stand, tripod, bracket or table. The apparatus may fall, causing serious personal injury and damage to the apparatus.
9. Do not block or cover any openings in the apparatus. These are provided for ventilation and protection from overheating. Never place the apparatus near any heat sources such as radiators, heat registers, stoves, or other apparatus (including amplifiers) that produce heat. Do not place the apparatus in an enclosure such as a cabinet without proper ventilation.
10. Operate the apparatus using only the type of power source indicated on the marking label. Unplug the apparatus' power cord by gripping the power plug, not the cord.
11. Insert the plug properly. Do not defeat the safety purpose of the polarized or grounding-type plug. An American polarized AC line plug has two blades with one wider than the other. This plug will fit only one way into the power outlet. This is a safety feature. If you are unable to insert the plug fully into the outlet, try reversing the plug. If the plug still fails to fit, contact an electrician to replace the obsolete outlet. A grounding type plug has two blades and a third grounding prong. The wide blade or the third prong are provided for your safety. If the provided plug does not fit into your outlet, consult an electrician to replace the obsolete outlet.
12. Route power supply cords so that they are not likely to be walked on or pinched by items placed upon or against them. Pay particular attention to cords at plugs, convenience receptacles, and the point where they exit from the apparatus.
13. Do not overload wall outlets or extension cords, as this can result in a risk of fire or electrical shock.
14. Unplug this apparatus during lightning storms or when unused for long periods of time.
15. Never insert objects of any kind into the apparatus through openings, as the objects may touch Dangerous voltage points or short out parts. This could cause fire or electrical shock.
16. Refer all servicing to qualified service personnel. Servicing is required when the apparatus has been damaged in any way, such as when the power-supply cord or plug is damaged, liquid has been spilled or objects have fallen into the apparatus, the apparatus has been exposed to rain or moisture, does not operate normally, or has been dropped.

## 2.0 UNPACKING

The shipping carton contains the parts listed below

- \* The BS 287
- \* Mains power cable
- \* Spare fuses
- \* User manual

If any are missing, contact your dealer.

ASL has taken great care to ensure that this product reaches you in flawless condition.

After unpacking the unit please inspect for any physical damage to the unit, and retain the shipping carton and relevant packing materials for use should the unit need returning. If any damage has occurred, please notify your dealer immediately so that a written claim can be initiated. Please also refer to the warranty section of this manual.

## 3.0 WARRANTY

This unit is warranted by ASL Intercom to the original end-user purchaser against defects in workmanship and materials in its manufacture for a period of one year from date of shipment to the end-user.

Faults arising from misuse, unauthorized modifications or accidents are not covered by this warranty. If the unit is faulty it should be sent in its original packing, to the supplier or your local ASL dealer, with shipping prepaid. A note must be included stating the faults found and a copy of the original suppliers invoice.

## 4.0 MECHANICAL INSTALLATION

For the BS 287 a vertical rack space of 1U (1.75", 44mm) is required. It is not necessary to provide rear support by extra bracing or shelving. Adequate ventilation must be provided by allowing sufficient space around the sides and rear of the unit to ensure free circulation of air.

Forced cooling is not required.

The power supply regulator is mounted on the rear of the unit; after a period of time it will feel hot to the touch. This is quite normal, and should be no cause for alarm.

## 5.0 MAINS POWER & SAFETY EARTH

### Connecting to mains power

The BS 287 may be connected to a mains power outlet which provides 100 – 240 V AC, 50-60 Hz and at least 60 watts. The outlet should have a clean earth. Avoid using mains power outlets which also power dimmer controlled lighting equipment.

The wires in the mains lead are color coded:

green/yellow: Earth / safety ground  
blue: Neutral  
brown: Live

In case the wires in the mains lead do not correspond with the colored markings identifying the terminals in your mains plug, proceed as follows:

- The wire which is colored green/yellow must be connected to the terminal in the plug which is marked with the letter "E", or by the ground symbol, or is colored green.

- The wire which is colored blue must be connected to the terminal which is marked with the letter "N" or colored black.
- The wire which is colored brown must be connected to the terminal which is marked with the letter "L" or colored red.

### Safety Earth

**The green/yellow wire of the mains lead must always be connected to the electrical installation safety earth or ground.** This is essential for personal safety as well as for proper operation of the BS 287 and connected stations. In the BS 287 the green/yellow wire is connected to all exposed metal surfaces. Any rack framework into which this unit might be mounted is assumed to be connected to the same grounding circuit.

## 6.0 GENERAL DESCRIPTION

The BS 287 is a dual channel power supply to be used in an ASL intercom system. The unit is ideal for use in applications where standard microphone cable is available and ease of setup is of paramount importance. The unit can drive at least 15 Basic Series beltpacks operating at full power.

The dual channel power supply is fully protected against wiring mistakes (reverse power), short circuit

or dangerous thermal condition.

Should one of these conditions occur, the unit shuts down. Once the fault condition has been removed, the BS 287 resets automatically and full power is restored.

An Aux input – with ground lift switch - at the rear panel allows injecting external line level audio signals into the intercom lines with on the front panel a volume control for each channel.

## 7.0 FRONT PANEL CONTROLS & CONNECTOR

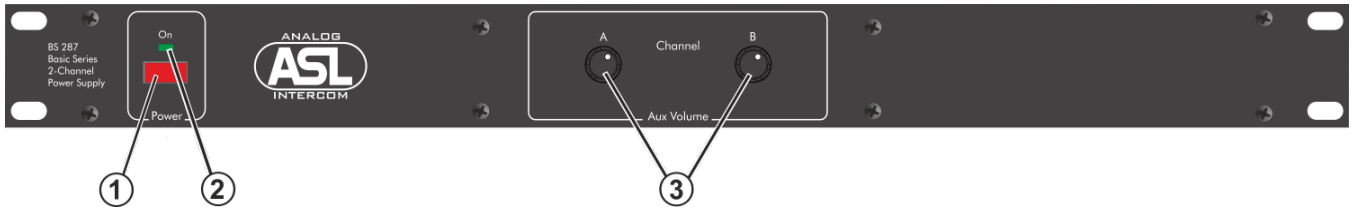

### 1 POWER ON/OFF switch

Mains power push button for switching ON and OFF the internal power supply.

### 2 MAINS POWER LED

This LED illuminates if the unit is switched on.

### 3 AUX VOLUME control knobs

These knobs adjust the level of the AUX input to each of the two intercom lines.

## 8.0 REAR PANEL CONTROLS & CONNECTORS

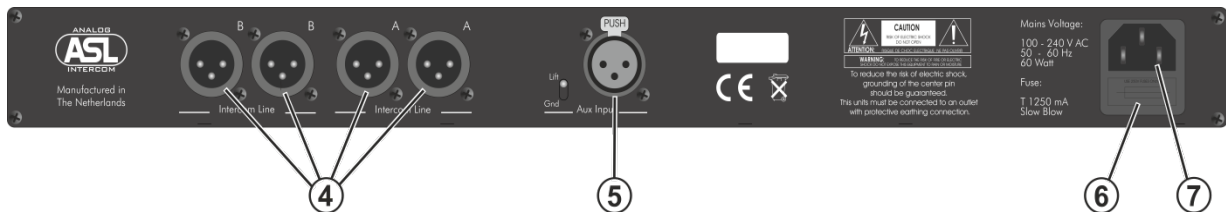

### 4 A & B LINE connectors

These XLR-3 type connectors are for connecting remote stations, using standard microphone cable. There are 2 connectors for channel A and 2 connectors for channel B.

Pin assignments:

- Pin 1: 0V / ground shield
- Pin 2: +30V DC power wire
- Pin 3: audio wire

Pin assignments :

- Pin 1. 0V / ground
- Pin 2: signal +
- Pin 3: signal -

### 5 AUX INPUT connector + GND lift

This XLR-3 input is electronically balanced and accepts line level audio signals. Ground can be lifted.

### 6 FUSE Holder

The fuse protects the BS 286 against severe internal damage, in case of malfunction in the power section. **Before replacing a fuse the mains cord must be disconnected from the mains outlet.**

### 7 MAINS Inlet

IEC Mains connector

## 9.0 TECHNICAL SPECIFICATIONS

### System

Dynamic range: 80 dB (1kHz, THD <1%)  
Frequency response: 200 Hz – 15 kHz (-3 dB)  
Call signal (send): +2.8 mA  
Call signal threshold (receive): +2.4 V DC  
Operating voltage: +30 V DC

### Intercom line

Impedance: 350  $\Omega$  (1 kHz), 2.2 k $\Omega$  (DC)  
Audio level: nom. -18 dBu, max. +4 dBu

### Switch Mode Power Supply

Mains voltage: 100 - 240 V AC, 50/60 Hz  
Output voltage: +30 V DC (+/- 5%)  
Max output power: 45 W  
Max power consumption: 60 watts

### Aux Input

Input Impedance: 33 k $\Omega$   
Nominal Input Level: 0 dBu  
Max. Input Level: +22 dBu

### BS 287 Dimensions & Weight

Width: 19" (483 mm) / Height: 1RU (44.5 mm)  
Depth: 140 mm / Weight: 1.5 Kg

*0 dBu defined as 775 mV rms into open circuit.*

*ASL reserves the right to alter specifications without prior notice*

## 10.0 PARTY LINE, TECHNICAL CONCEPT

User stations in an ASL intercom system are connected via one or several 'party lines'. A party line offers two way ('full duplex') communication and consists of standard microphone (multi-pair) cable. One wire is used as an audio line, one as a power line and the screen of the cable functions as earth/return. Current drive is used for signal transfer. Each station utilizes a current amplifier to amplify the microphone signal and place it on the common audio line where, due to the constant line impedance (situated in the power supply between XLR pin 3 and 1), a signal voltage is developed which can be further amplified and sent to the headphones or loudspeakers.

This principle has three advantages:

- the use of a single audio line allows several stations to talk and listen simultaneously
- due to the high bridging impedance offered by each station, the number of stations on the party line has no influence on the level of the communications signal
- power and audio to the intercom stations use the same cable

The Call signal is also sent as a current on the audio line. It develops a DC potential over the line impedance which will be sensed by each station and be interpreted as a Call signal.

## 11.0 CABLING

The intercom lines (the 'party lines') are of the shielded two-conductor microphone cable type. The intercom line connectors are of the XLR-3 type. Audio and Call signals are on XLR pin 3, DC power is on XLR pin 2. XLR pin 1 is connected to the shield of the cable which functions as the common return for audio and power. The audio signal is transferred in an unbalanced way (see 'Party Line, Technical Concept'). To avoid earth loops (hum), the possible effect of electromagnetic fields and to minimize power loss, certain rules have to be obeyed when installing the cabling of an intercom system :

### Use high quality cable

Use high quality microphone cable (shielded two conductor cable, minimum 2x 0.30 mm<sup>2</sup>). In case multi-pair microphone cable is used, it should be of high quality and each pair should consist of two conductors (minimum 2x 0.15 mm<sup>2</sup>) with separate shield and an overall shield.

### Use flexible cable

Use flexible single and multi-pair microphone cable instead of cable with solid cores, especially when the cable is subjected to bending during operation or installation.

### Cable screens to XLR pin 1

The screen of each separate microphone cable and/or the screen of each single pair in a multi-pair cable, should be connected to pin 1 of each XLR-3 connector. Do not connect these screens to the metal housing of ASL units or XLR-3 wall boxes.

### Connect metal cable trunks, wall boxes and overall multi-pair cable screens to clean earth

Metal cable trunks, metal wall boxes and overall multi-pair cable screens should be interconnected and, at the 'central earth point' in the intercom network only, be connected to a clean earth or a safety earth.

### Keep metal connection boxes and cable trunks or pipes isolated from other metal parts

Metal trunks or pipes for intercom cables and metal connection boxes should be mounted in such a way that they are isolated from any other metal housing or construction part.

### Keep cables parallel as much as possible

When two (multi channel) units in a network are connected by more than one cable, make sure that these cables are parallel to each other over the whole distance between those units. When using multi-pair cable, parallelism is ensured in the best possible way.

### Avoid closed loops

Always avoid that intercom cables are making a closed loop. So-called 'ring intercom' should not physically be cabled as a ring.

### Keep cables away from electromagnetic sources

Keep intercom cables away from high energy cables, e.g. 115/230/400V mains power or dimmer controlled feeds for spotlights. Intercom cables should cross high energy cables at an angle of 90° only. Intercom cables should never be in the same trunks as energy cables.

### Place power supply in a central position

In case of a system powered by a separate power supply: In order to diminish power losses, place the power supply as close as possible to where most power consumption occurs, in other words most user stations are placed.

### ASL powered units to a 'clean' mains outlet

Master stations or power supplies should be connected to a mains outlet with a clean earth. Other audio equipment may be connected to this mains outlet, but avoid using an outlet which also powers dimmer controlled lighting systems.

In case of more complex installations, don't hesitate to contact us. Please send us a block diagram of the planned network with a list of all user stations and their positions, and we are happy to advise you on cabling lay out.

## 12.0 EARTHING CONCEPT

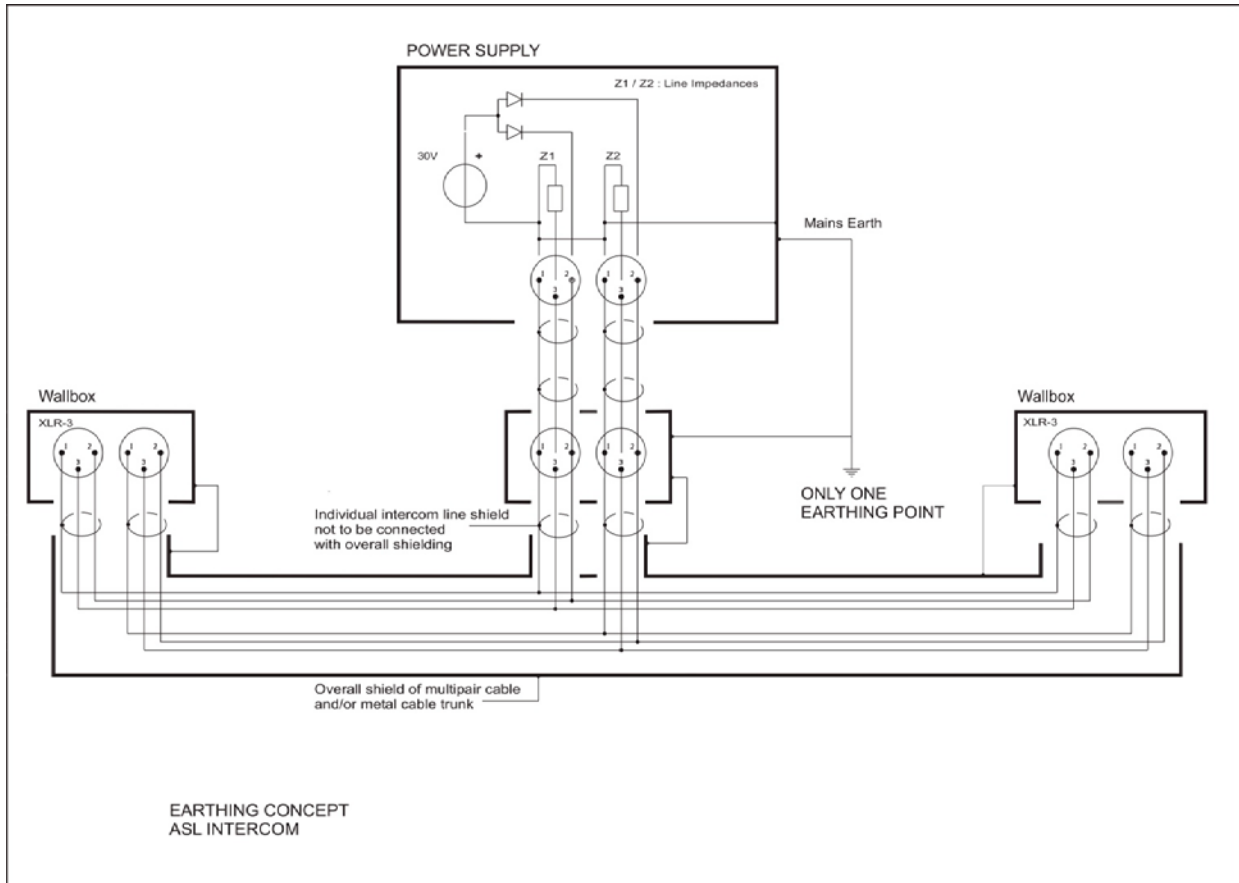

## 13.0 BS 287 BLOCK DIAGRAM

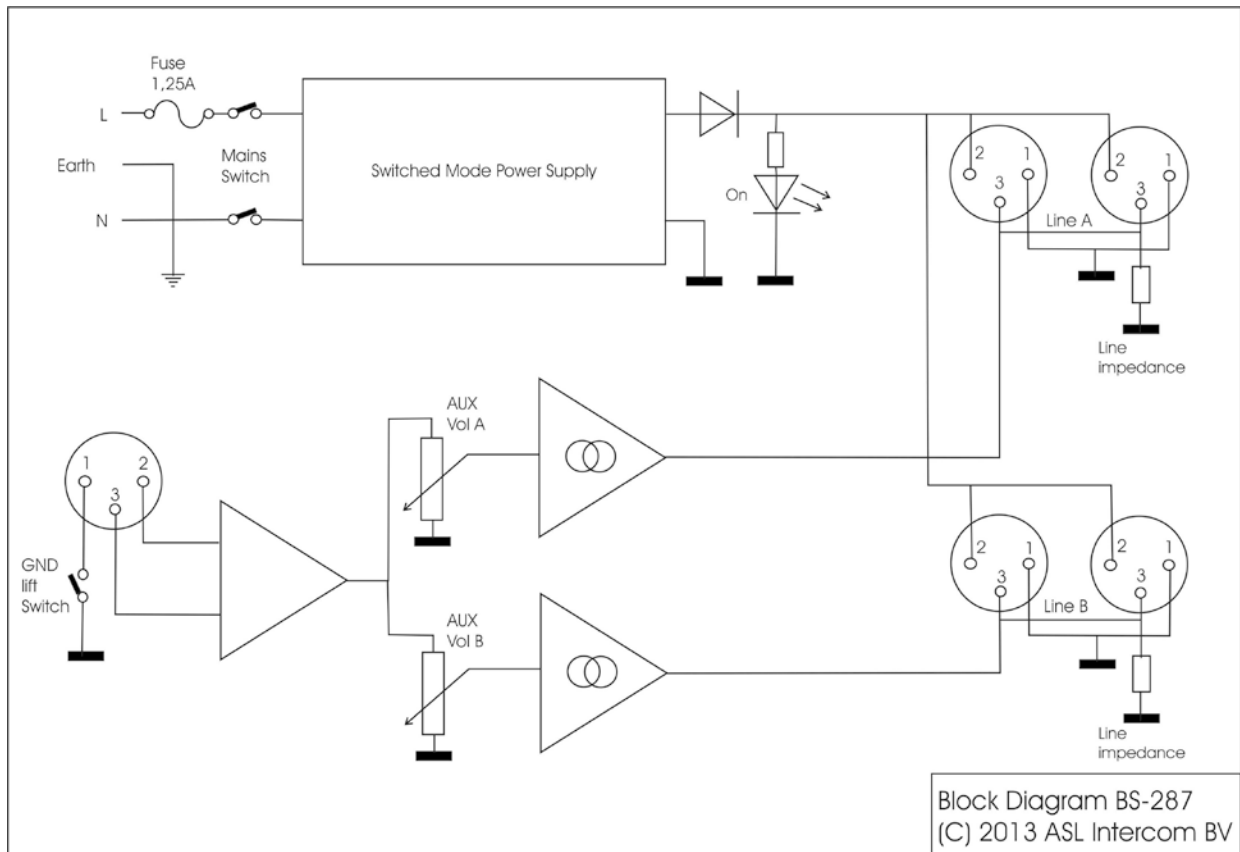

**14.0 POSSIBLE SYSTEM CONFIGURATION**

