

- EN** Installation, Operation and Maintenance Instructions
FR Instructions d'installation, d'utilisation et d'entretien
ES Instrucciones de instalación, operación y mantenimiento

Refrigerated Drawers
Tiroirs réfrigérés
Gavetas refrigeradas

ML24RD



CONTENTS

Contents:

Safety information	2
Unpacking your appliance	3
Warranty registration	3
Installing your appliance	4
Cabinet clearances	4
Leveling the appliance	4
Electrical connection	5
Installing the anti-tip device	6
Product Dimensions	8
Using your Electronic control	10
Starting your appliance	10
Sleep mode	10
Turning your appliance "ON" or "OFF"	10
Adjusting the temperature	11
Temperature mode	11
Control lock	11
Alarms	11
Door (drawer) ajar.....	11
Power failure	12
Temperature alarm	12
Vacation mode	12
Overlay drawer panel installation	13
Care and cleaning	16
Energy saving tips	16
Obtaining service	17
Troubleshooting	18
Warranty	19

Important Safety Instructions

Warnings and safety instructions appearing in this guide are not meant to cover all possible conditions and situations that may occur. Common sense, caution, and care must be exercised when installing, maintaining, or operating this appliance.

Recognize Safety Symbols, Words, and Labels.



WARNING

WARNING - You can be killed or seriously injured if you do not follow these instructions.



CAUTION

CAUTION-Hazards or unsafe practices which could result in personal injury or property / product damage.

NOTE

NOTE-Important information to help assure a problem free installation and operation.

State of California Proposition 65 Warnings:

WARNING: This product contains one or more chemicals known to the State of California to cause cancer.

WARNING: This product contains one or more chemicals known to the State of California to cause birth defects or other reproductive harm..



AGA MARVEL is committed to building a quality product in an environmentally friendly manner. Our processes are tightly controlled and closely monitored. We have achieved certifications in ISO 9001 for quality assurance, ISO 14001 for environmental management, and OHSAS 18001 for occupational health and safety from Lloyd's Register Quality Assurance.

UNPACKING YOUR APPLIANCE



WARNING

EXCESSIVE WEIGHT HAZARD

Use two or more people to move product.
Failure to do so can result in personal injury.

Remove Interior Packaging

Your appliance has been packed for shipment with all parts that could be damaged by movement securely fastened. Remove internal packing materials and any tape holding internal components in place. The owners manual is shipped inside the product in a plastic bag along with the warranty registration card, and other accessory items.

Important

Keep your carton and packaging until your appliance has been thoroughly inspected and found to be in good condition. If there is damage, the packaging will be needed as proof of damage in transit. Afterwards please dispose of all items responsibly.



CAUTION

Dispose of the plastic bags which can be a suffocation hazard.

Note to Customer

This merchandise was carefully packed and thoroughly inspected before leaving our plant. Responsibility for its safe delivery was assumed by the retailer upon acceptance of the shipment. Claims for loss or damage sustained in transit must be made to the retailer.

NOTE

DO NOT RETURN DAMAGED MERCHANDISE TO THE MANUFACTURER - FILE THE CLAIM WITH THE RETAILER.



CAUTION

If the appliance was shipped, handled, or stored in other than an upright position for any period of time, allow the appliance to sit upright for a period of at least 24 hours before plugging in. This will assure oil returns to the compressor. Plugging the appliance in immediately may cause damage to internal parts.

Warranty Registration

It is important you send in your warranty registration card immediately after taking delivery of your appliance or you can register online at www.agamarvel.com.

The following information will be required when registering your appliance.

Service Number

Serial Number

Date of Purchase

Dealer's name and address

Online registration
available at
www.agamarvel.com

The service number and serial number can be found on the serial plate which is located inside the cabinet on the bottom of the liner toward the left side. Open the bottom drawer to view it. See figure 1.

AGA MARVEL	
GREENVILLE, MI 48838	
MODEL NO.	<input type="text"/>
SERVICE NO.	<input type="text" value="XXXXXXXXXX"/>
SERIAL NO.	<input type="text" value="XXXXXXXXXX"/>
HZ <input type="text"/>	VOLTS <input type="text"/>
AMPS <input type="text"/>	R134A <input type="text"/>
oz	
TEST PRESSURE 140 PSI LOW SIDE 300 PSI HIGH SIDE	

Figure 1



CAUTION

Help Prevent Tragedies

Child entrapment and suffocation are not problems of the past. Junked or abandoned refrigerators are still dangerous - even if they sit out for "just a few days".

If you are getting rid of your old refrigerator, please follow the instructions below to help prevent accidents.

Before you throw away your old refrigerator or freezer:

- Take off the doors or remove the drawers.
- Leave the shelves in place so children may not easily climb inside.

INSTALLING YOUR APPLIANCE

Select Location

The proper location will ensure peak performance of your appliance. We recommend a location where the unit will be out of direct sunlight and away from heat sources. To ensure your product performs to specifications, the recommended installation location temperature range is from 55 to 100°F (13 to 38°C).

Cabinet Clearance

Ventilation is required from the bottom front of the appliance. Keep this area open and clear of any obstructions. Adjacent cabinets and counter top can be installed around the appliance as long as the front grille remains unobstructed.

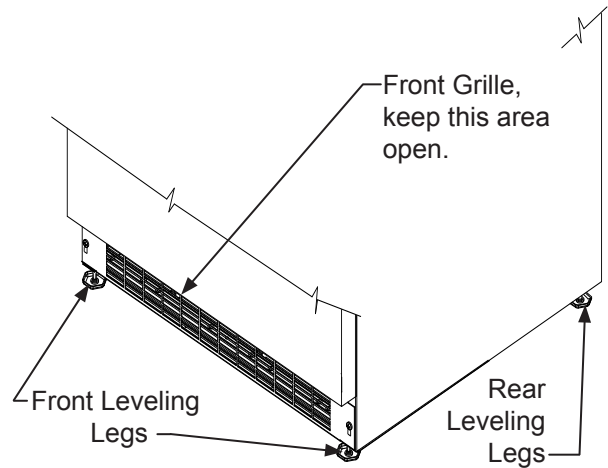

Figure 2



WARNING

An optional stacking kit, shown in Table "A", is required to stack products. Failure to use a stacking kit could result in personal injury. Contact your dealer or Aga Marvel customer service at 800-223-3900 to order.

Leveling Legs

Adjustable legs at the front and rear corners of the appliance should be set so the unit is firmly positioned on the floor and level from side to side and front to back. The overall height of your Marvel appliance may be adjusted between the minimum, 33³/₄" (85.7 cm), by turning the leveling leg in (CW ↻) and the maximum, 34³/₄" (88.3 cm) by turning the leveling leg out (CCW ↻).

To adjust the leveling legs, place the appliance on a solid surface and protect the floor beneath the legs to avoid scratching the floor. With the assistance of another person, lean the appliance back to access the front leveling legs. Raise or lower the legs to the required dimension by turning the legs. Repeat this process for the rear by tilting the appliance forward using caution. On a level surface check the appliance for levelness and adjust accordingly.

The front grille screws may be loosened and the grille adjusted to the desired height. When adjustment is complete tighten the two front grille screws. (See Figure 3).

Color	Door Swing	Kit Part Number
Stainless Steel	Left Hand	42249095
Stainless Steel	Right Hand	42249096
Black	Left Hand	42249097
Black	Right Hand	42249098
White	Left Hand	42249099
White	Right Hand	42249100

Table A



CAUTION

Front Grille

Do not obstruct the front grille. The openings within the front grille allow air to flow through the condenser heat exchanger. Restrictions to this air flow will result in increased energy usage and loss of cooling capacity. For this reason it is important this area not be obstructed and the grille openings kept clean. AGA MARVEL does not recommend the use of a custom made grille as air flow may be restricted (See Figure 2).

INSTALLING YOUR APPLIANCE

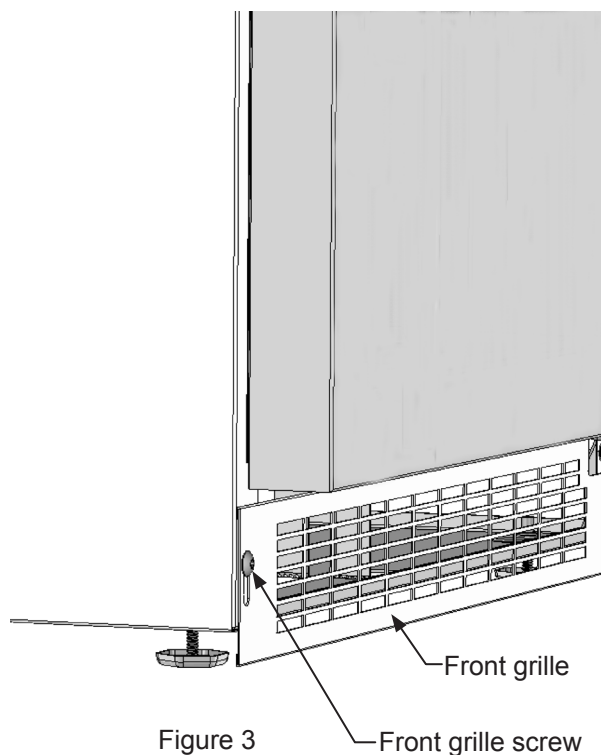

WARNING

Electrical Shock Hazard

- Do not use an extension cord with this appliance. They can be hazardous and can degrade product performance.
- This appliance should not, under any circumstances, be installed to an un-grounded electrical supply.
- Do not remove the grounding prong from the power cord.
- Do not use an adapter.
- Do not splash or spray water from a hose on the appliance. Doing so may cause an electrical shock, which may result in severe injury or death.

Electrical Connection

A grounded 115 volt, 15 amp dedicated circuit is required.

This product is factory equipped with a power supply cord that has a three-pronged, grounded plug. It must be plugged into a mating grounding type receptacle in accordance with the National Electrical Code and applicable local codes and ordinances (see Figure 4). If the circuit does not have a grounding type receptacle, it is the responsibility and obligation of the customer to provide the proper power supply. The third ground prong should not, under any circumstances, be cut or removed.

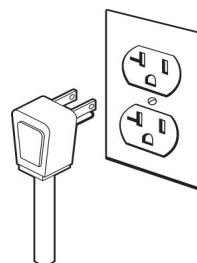





Figure 4

NOTE

Ground Fault Circuit Interrupters (GFCI) are prone to nuisance tripping which will cause the appliance to shut down. GFCI's are generally not used on circuits with power equipment that must run unattended for long periods of time, unless required to meet local building codes and ordinances.

INSTALLING THE ANTI TIP DEVICE

**WARNING**



- ALL APPLIANCES CAN TIP RESULTING IN INJURY.
- INSTALL THE ANTI-TIP BRACKET PACKED WITH THE APPLIANCE.
- FOLLOW THE INSTRUCTIONS BELOW

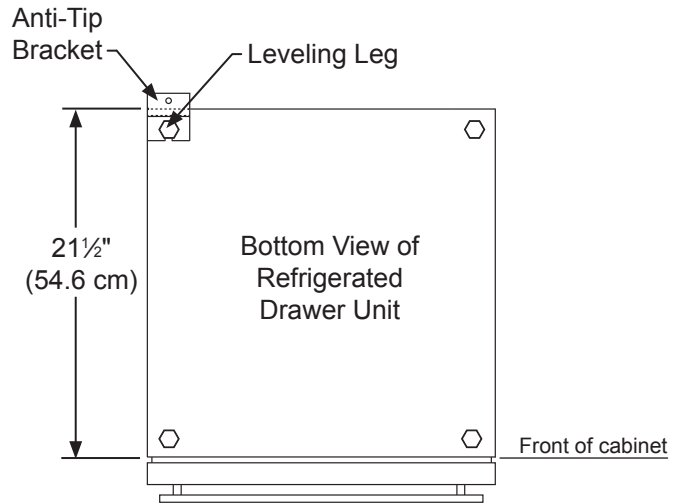

Figure 5

Anti-Tip Device

**CAUTION**

If your drawer refrigerator is not located under a counter top (free standing), you must use an anti-tip device installed as per these instructions. If the drawer refrigerator is removed from its location for any reason, make sure that the device is properly engaged when you push the drawer refrigerator back into the original location. If the device is not properly engaged, there is a risk of the drawer refrigerator tipping over, with the potential for property damage or personal injury.

NOTE

If installing on concrete floor, concrete fasteners are required, (not included with the anti-tip kit).

**CAUTION**

Any finished flooring should be protected with appropriate material to avoid damage when moving the unit.

Floor Mount Installation

The anti-tip bracket is to be located on the floor in the left or right rear corner of the refrigerator drawer as shown in Figure 5.

Step by step instructions for locating the position of the bracket:

- 1) Decide where you want to place the drawer refrigerator. Slide it into place, being careful not to damage the floor, leaving 1" (2.5 cm) of clearance from the rear wall to allow room for the anti-tip bracket.
- 2) Raise the rear leveling legs approximately $\frac{1}{4}$ " (6 mm) to allow engagement with the anti-tip bracket. Level the unit by adjusting all the leveling legs as required. Turning the leveling leg counterclockwise will raise the unit and clockwise will lower the unit.
- 3) Make sure the refrigerator is in the desired location, then mark on the floor the rear and side corner of the cabinet where the anti-tip bracket will be installed. If the installation does not allow marking the rear corner of the cabinet, then make temporary lines on the floor marking the front corner of the cabinet, excluding the drawer. Slide the refrigerator out of the way. From the temporary line extend the sidewall line back 21 $\frac{1}{2}$ " (54.6 cm) as shown in Figure 6.
- 4) Align the anti-tip bracket to the marks on the floor so the side of the bracket lines up with the side of the cabinet mark, and the "V" notches on the anti-tip bracket line up with the end of the 21 $\frac{1}{2}$ " (54.6 cm) line (Rear of cabinet line).
- 5) Fasten the anti-tip bracket to the floor using the supplied screw. (See Figure 6).
- 6) Slide the cabinet back into position, making sure the rear cabinet leveling leg slides under the anti-tip bracket engaging the slot.

INSTALLING THE ANTI TIP DEVICE



WARNING

TIP OVER HAZARD: One of the rear cabinet leveling legs must be engaged under an anti-tip bracket.

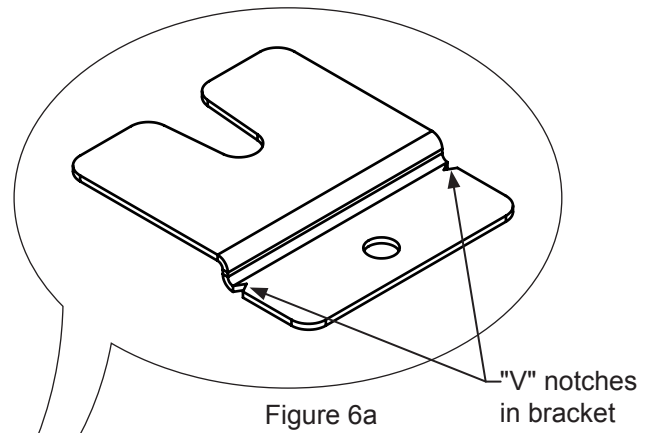
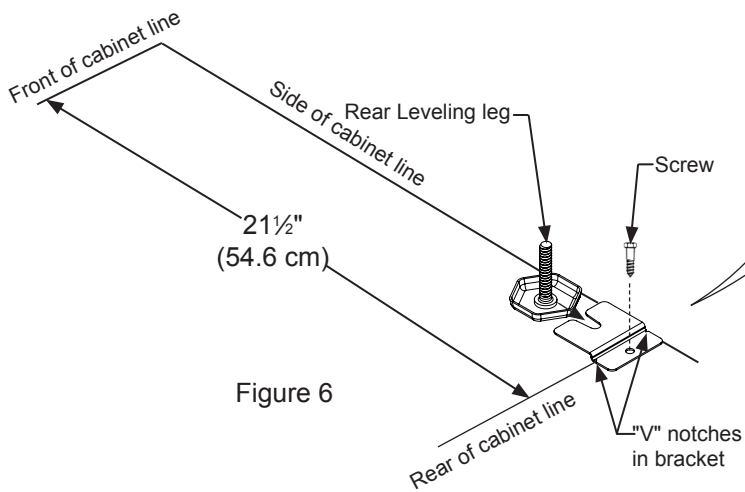

PRODUCT DIMENSIONS

MODEL	ROUGH-IN OPENING DIMENSIONS			CABINET DIMENSIONS				
	"A"	"B"	"C"	"D"	"E"	"F"	"G"	"H"
ML24RDS	24" (61 cm)	**34" to 35" (86.4 cm to 88.9 cm)	*	23 ⁷ / ₈ " (60.7 cm)	33 ³ / ₄ " to 34 ³ / ₄ " (85.7 cm to 88.3 cm)	23 ²³ / ₃₂ " (60.2 cm)	25 ² / ₃₂ " (65.2 cm)	39 ⁵ / ₃₂ " (99.5 cm)
ML24RDP	24" (61 cm)	**34" to 35" (86.4 cm to 88.9 cm)	*	23 ⁷ / ₈ " (60.7 cm)	33 ³ / ₄ " to 34 ³ / ₄ " (85.7 cm to 88.3 cm)	22 ⁷ / ₈ " (58.1 cm)	-	38 ⁵ / ₁₆ " (97.3 cm)

DRAWER STYLE
(S) Solid Drawer
(P) Solid Overlay Drawer (no handle)

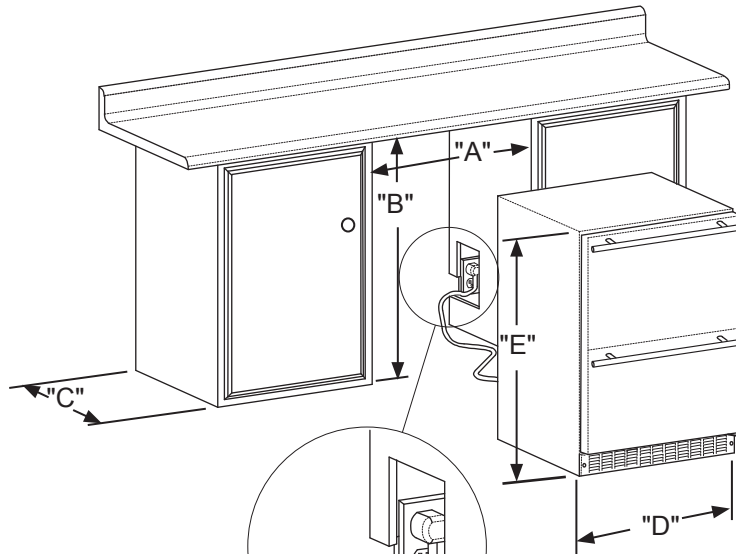

Figure 7

Figure 7a

If necessary to gain clearance inside the rough-in opening a hole can be cut through the adjacent cabinet and the power cord routed through this hole to a power outlet. Another way to increase the available opening depth is to recess the power outlet into the rear wall 1" (2.5 cm) to gain the thickness of the power cord plug.

PRODUCT DIMENSIONS

PRODUCT DATA		
MODEL	ELECTRICAL REQUIREMENTS #	PRODUCT WEIGHT
ML24RDS	115V/60Hz/15A	130 lbs (59 kg)
ML24RDP	115V/60Hz/15A	130 lbs (59 kg)

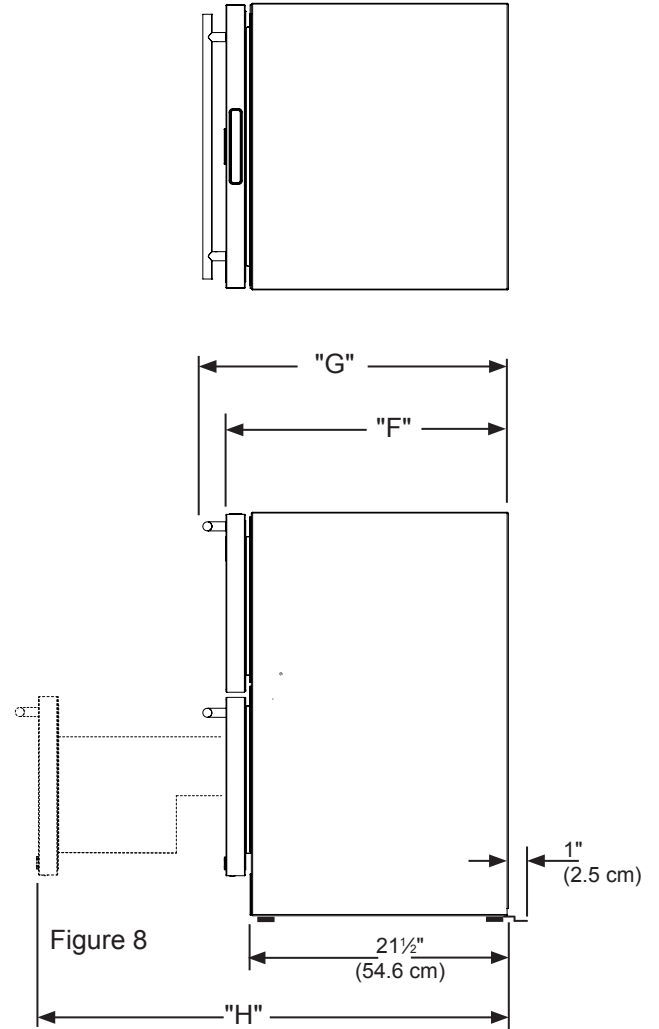
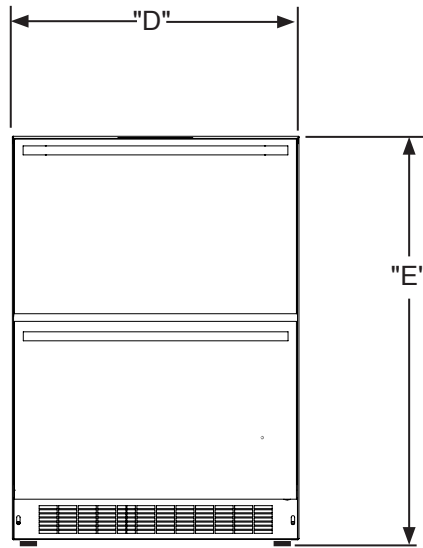

* Depth dimension of rough-in opening may vary depending on each individual installation. To recess entire drawer "F" dimension plus 1" (2.5 cm) for thickness of power cord plug is required.

** Minimum rough-in opening required is to be larger than the adjusted height of the cabinet.

A grounded 15 amp dedicated circuit is required. Follow all local building codes when installing electrical and appliance.



WARNING

Floor mount Anti-tip Bracket must be installed for freestanding applications. Not required for built in applications.

USING YOUR ELECTRONIC CONTROL

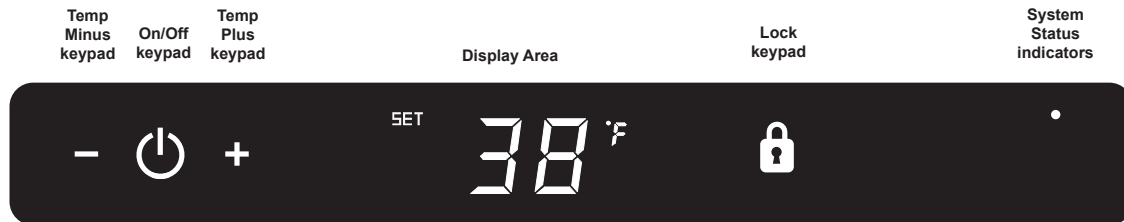

Figure 9
Electronic single zone control



To wake the display press any keypad. A confirm tone will sound, and the current storage compartment temperature will be displayed.

Starting your appliance:

Plug the appliance power cord into a 115 volt wall outlet. Your appliance is shipped from the factory in the "On" position and will begin start-up of cooling as soon as power is supplied. If the appliance does not start, confirm that the wall outlet has power, and that the control is in the "On" position, (See "Turning your appliance On and Off" below).

The control display is covered with a clear plastic film. This film may be removed by carefully lifting the film at a corner.

On initial power up, the control display will indicate a "Power Failure" alarm. This is a normal condition as the appliance was powered-up at the factory for quality inspection and then removed from power. A momentary press of the "On/Off" keypad will reset this alarm condition. (See Alarms section on page 11).

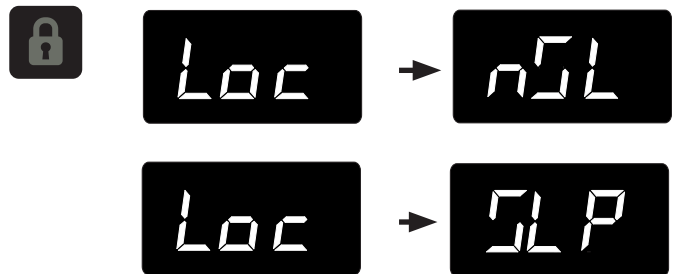

The sleep mode can be disabled if you prefer to have the display on continuously. Press and hold the "Lock" keypad until the display goes past "Loc" and reads "nSL". To enable the sleep mode, repeat the instruction, again going past "Loc" until the display reads "SLP".



Sleep mode:

If no keypads are pressed for 60 seconds, the display will enter sleep mode to conserve power. The control panel will go dark with the exception of the system status "OK" indicator which will remain enabled. Alarm conditions will wake the display, (see alarms on page 11).

To make the following changes to the control settings (turning the appliance ON/OFF, adjusting the temperature, and activating vacation mode), the control must be awake.



To turn the appliance "On", press and hold the "On/Off" keypad for 4-seconds.

USING YOUR ELECTRONIC CONTROL



Adjusting the temperature:

To set or check the set-point temperature (with the control out of sleep mode), press the "-" or "+" keypads. "SET" will be indicated on the user interface panel and the current set-point temperature will display and flash. Subsequent presses of the "-" or "+" keypads will adjust the temperature colder or warmer respectively. When you have reached your desired set-point temperature, press the "On/Off" keypad to accept, or do nothing and the "Set" mode will time-out in 10-seconds accepting the displayed temperature as the new set-point.

The available set-point temperature range for your appliance is 34°F (1.2°C) to 42°F (5.7°C). If you attempt to adjust the temperature outside of this range you will receive an audible notification.

When initially loading your product with warm contents, it may take up to 48-hours for the storage compartment temperature to stabilize.

When making temperature set-point changes, it may take up to 24-hours for the stored contents to stabilize at your new set-point temperature.

Factors that affect the storage compartment stabilized temperature:

- Changes to temperature setting.
- Room temperature changes.
- Temperature of stored contents.
 - Loading warm contents.
 - Cold content load will delay the change to a warmer set-point temperature.
 - Warm content load will delay the change to a colder set-point temperature.
- Usage, (number and duration of the drawer openings).
- Installation of the appliance in direct sunlight or next to a heat source.

Temperature mode:

The temperature mode is preset from the factory in Fahrenheit (°F) but you have the option to change it to Centigrade (°C). To change the mode, press and hold the "-" keypad, while pressing the "+" keypad, then release the "-" keypad. The temperature will now be displayed in Centigrade (°C). Repeat the procedure to change the temperature mode back to Fahrenheit (°F).



Control lock:

The control panel can be locked to avoid unintentional changes. To lock the control, press and hold the "Lock" keypad until the display reads "Loc" then release your finger from the keypad. The lock icon will flash 3-times and then continuously illuminate. When the control panel is locked, only the Lock keypad, System Status OK indicator, and the Alarm indicator are active. To un-lock the control panel, repeat this instruction until the display reads "nLc".

Alarms:

The control will alert you to conditions that could adversely affect the performance of the appliance.

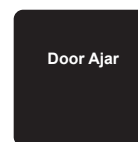

- **Door ajar** - If a drawer is open, or not closed properly, for more than 5-minutes the System Status OK indicator will turn-off, the "Door Ajar" indicator will flash, and a tone will sound every 60 seconds. Additionally, an "ALARM RESET" indicator will be displayed below the "On/Off" keypad. This alarm condition can be reset by closing the drawer or momentarily pressing the "On/Off" keypad, (i.e.-if you are cleaning the storage compartment, etc.). The alarm will recur in 5-minutes if the alarm condition persists.

USING YOUR ELECTRONIC CONTROL



- **Power failure** - If power to the appliance is interrupted the System Status indicator will turn-off and the "Power Failure" indicator will flash. Additionally, an "ALARM RESET" indicator will be displayed below the "On/Off" keypad. No audible tone will sound. This alarm condition can be reset by momentarily pressing the "On/Off" keypad. If this alarm occurs, it is recommended that you check the condition of any perishables, even if the appliance is operating normally and the temperature has recovered, as prolonged power outages could result in excessive temperature excursions which may spoil perishables.

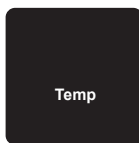

- **Temperature alarm** - If the storage compartment temperature exceeds 10°F from set-point for more than a 1-hour duration, the System Status indicator will turn off, the "Temp" indicator will flash, and an audible tone will sound every 60-seconds. Additionally, an "ALARM RESET" indicator will be displayed below the "On/Off" keypad. This alarm condition can be reset by momentarily pressing the "On/Off" keypad. If this alarm occurs it is recommended that you check the condition of your stored contents, even though the appliance is operating normally and the temperature has recovered, as prolonged temperature excursions could spoil perishables.

Vacation mode:

This operating mode can be used to save energy during high cost energy periods, or when you won't be using your appliance for an extended period of time by disabling the lights, alarm tones, and keypad entry tones. Vacation mode also serves as a Sabbath mode, disabling functions and its controls in accordance with the weekly Sabbath and religious holidays observed within the Orthodox Jewish community. When used as Sabbath mode, you may open or close a drawer at any time to access contents without concern of directly turning on or off any lights, digital read-outs, solenoids, fans, valves, compressor, icons, tones, or alarms.

When activated, the display, alarm indicators and tones, keypad touch tones, interior lights, and all options are disabled. All keypad functions are disabled, with the exception of the "On/Off" keypad which is required to exit Vacation mode. Storage compartment temperatures are monitored and controlled at the settings prior to entering Vacation mode.

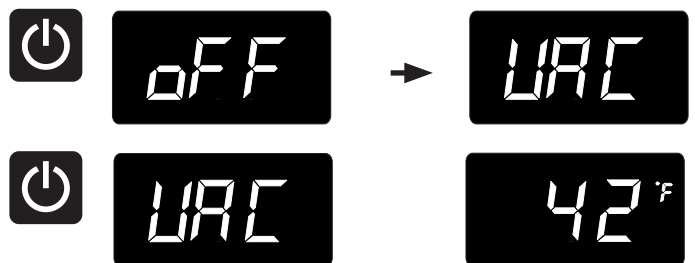

To enter Vacation Mode (with the control out of sleep mode), press and hold the "On/Off" keypad until the display goes past "OFF" and reads "VAC". The display will flash "VAC" 3-times to acknowledge your request, then will display "VAC" continuously until Vacation mode is exited. A power outage will not exit Vacation mode, exiting can only be accomplished manually. To exit Vacation mode and return to normal operation, press and hold the "On/Off" keypad until the control displays the temperature.

NOTE

Door Ajar
Temp

Multiple alarms are possible, i.e.- "Door Ajar" for a prolonged period may trigger a "Temp" alarm, in which case both "Door Ajar" and "Temp" indicators will activate.

OVERLAY DRAWER PANEL INSTALLATION



CAUTION

It is important to use the factory provided grille that came with the product to assure proper air flow is maintained through the condenser. The use of a custom grille is not recommended and will void the warranty.

Full Overlay Panel Installation Instructions Determine Wood Screw Requirements

1. A #10 pan head wood screw should be used to properly secure the overlay panel (See Figure 13). A quantity of 16 screws are supplied with the unit in the literature pack.
2. Use only pan head screws.
3. If your overlay panel is thinner than $\frac{5}{8}$ " (15.9 mm) you will need to purchase shorter screws. The longer screws will break through the front of the panel.

Step 1: Remove Drawers from unit.

1. Begin by pulling out the top drawer. (See Figure 10). Remove screws securing drawer to slides (See Figure 11). Pull drawer forward, lift up and out to clear clips in rear of drawer. Move drawer forward about 1" (2.5 cm) and set down on slides. At the right rear corner of the drawer disconnect the display wire harness (See Figure 10a). Remove the drawer from the unit by lifting up off of the slides. Repeat for bottom drawer but disregard the harness instructions as there is no wiring to the bottom drawer.
2. Remove the gasket from the drawer front. (See Figure 11). Do this by pulling the gasket out of the channel that holds it to the drawer front. This will expose the clearance holes for mounting the overlay panel. (See Figure 15).

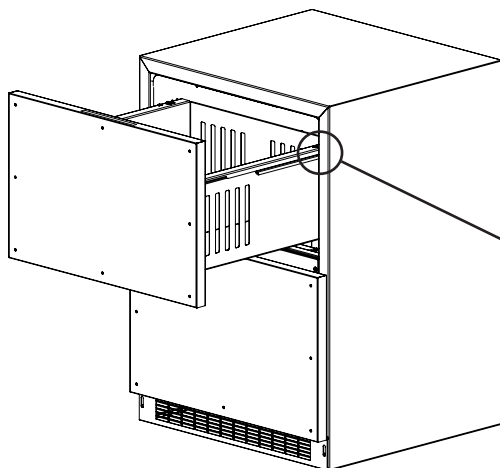

Figure 10

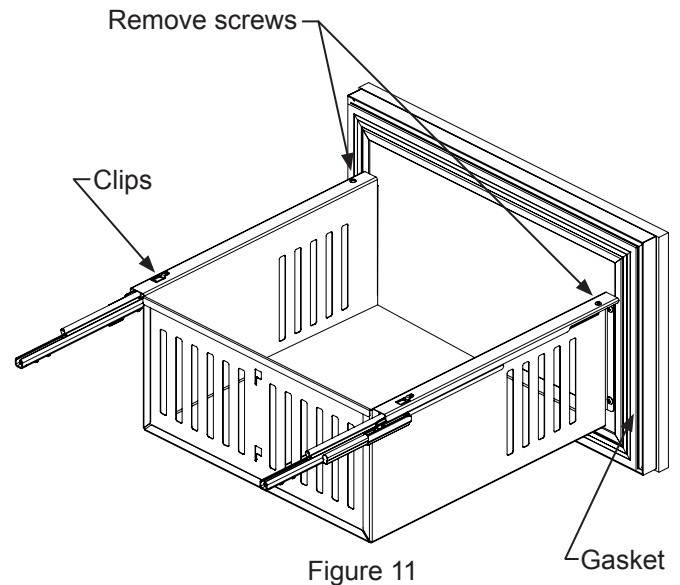

Figure 11

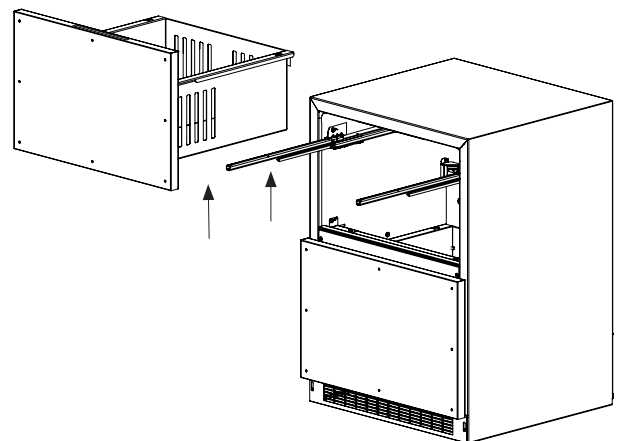

Figure 12

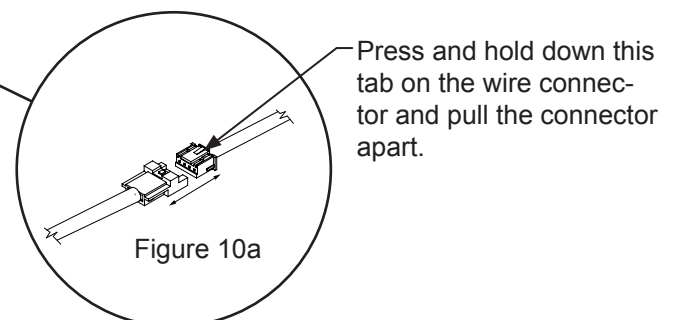

Figure 10a



WARNING

Electrocution Hazard

- Never attempt to repair or perform maintenance on the appliance until the main electrical power has been disconnected. Turning the appliance control "OFF" does not remove electrical power from the units wiring.
- Replace all parts and panels before operating.

OVERLAY DRAWER PANEL INSTALLATION

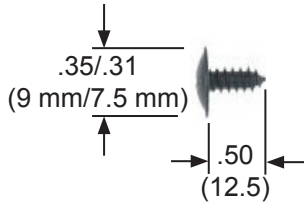

Figure 13

Step 3: Attach the Overlay Panel to the Drawer

1. Set the overlay panel on drawer front face and align edges. (See Figure 15 below). The custom overlay panel should be flush with the top of the drawer and centered on the width of the drawer. Clamp panel in position and mark pilot hole locations. Pick the required pilot hole size from "Table B" below and drill the pilot holes ensuring not to drill all the way through the overlay panel.

Table B: Pilot Hole Drill Sizes for Wood Screws

Material Type	#8 Wood Screw
Hardwood	1/8 Diameter Pilot Hole
Softwood	7/64 Diameter Pilot Hole

2. Insert wood screws through clearance holes and tighten to secure overlay panel.
3. Reinstall gasket into channel. Make sure the corners are fully inserted.

Step 2: Size the Overlay Panel

Cut the overlay panel to the dimensions shown below in Figure 14. On the top drawer only drill the 2 counter-bored holes which are clearance for screw heads on the face of the top drawer.

This is also a convenient time to locate and drill the holes for your handle. Most often the handle is to match that of the surrounding cabinetry. If your handle attaches from the back-side of the custom panel, locate the mounting holes while the panel is attached to the drawer and cabinet. After the panel is removed from the drawer, drill the mounting holes from the front, to the recommended diameter of the handle manufacturer. Counter bore the back-side of the panel so the screw heads do not interfere with the surface of the drawer.

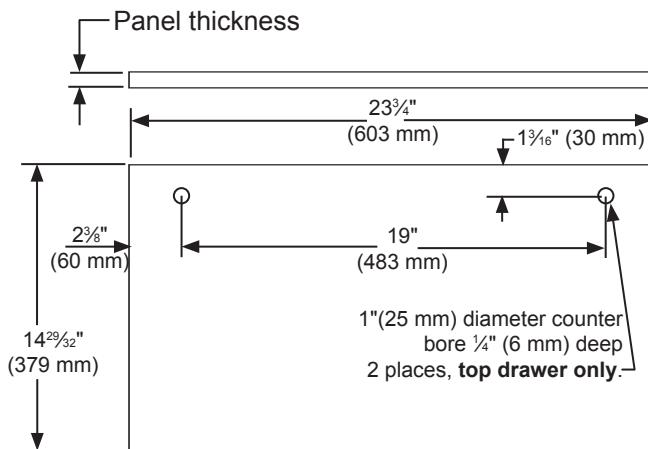
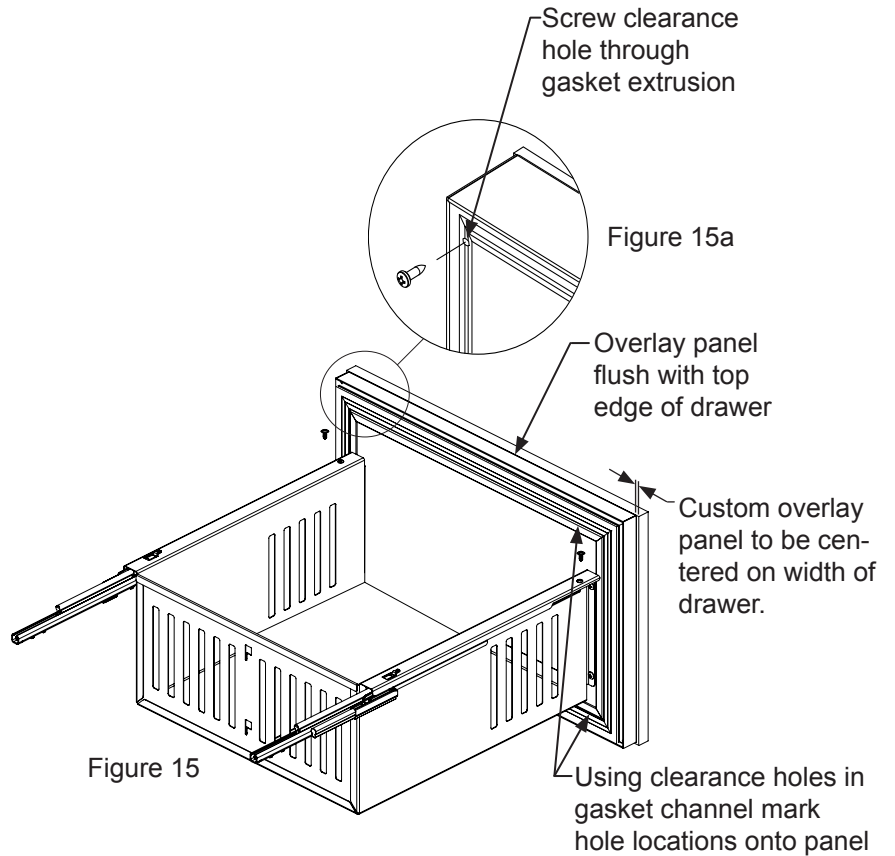

Figure 14
Face of
Overlay Panel
(This side facing interior)

OVERLAY DRAWER PANEL INSTALLATION

Step 4: Reinstall the Drawers

1. Fully extend drawer slides and place drawer on slides.
Be sure that drawer sits evenly on both slides and clips slide into place in rear of drawer.
2. Re-install wire harness at rear corner of top drawer.
3. Re-install two screws through drawer into slides.



CARE AND CLEANING AND ENERGY SAVING TIPS

Front Grille

Be sure that nothing obstructs the required air flow openings in front of the cabinet. At least once or twice a year, brush or vacuum lint and dirt from the front grille area (see page 4).



CAUTION

SHOCK HAZARD: Disconnect electrical power from the appliance before cleaning with soap and water.

Cabinet

The painted cabinet can be washed with either a mild soap and water and thoroughly rinsed with clear water. NEVER use abrasive scouring cleaners.

Interior

Wash interior compartment with mild soap and water. Do NOT use an abrasive cleaner, solvent, polish cleaner or undiluted detergent.

Care of Appliance

1. Avoid leaning on the drawer, you may bend the drawer hinges or tip the appliance.
2. Exercise caution when sweeping, vacuuming or mopping near the front of the appliance. Damage to the grille can occur.
3. Periodically clean the interior of the appliance as needed.
4. Periodically check and/or clean the front grille as needed.

In the Event of a Power Failure

If a power failure occurs, try to correct it as soon as possible. Minimize the number of drawer openings while the power is off so as not to adversely affect the appliance's temperature.

Light assembly replacement

All models use LED lamps to illuminate the interior of the appliance. This component is very reliable, but should one fail, contact a qualified service technician for replacement of the LED.

The following suggestions will minimize the cost of operating your refrigeration appliance.

1. Do not install your appliance next to a hot appliance (cooker, dishwasher, etc.), heating air duct, or other heat sources.
2. Install product out of direct sunlight.
3. Ensure the front grille vents at front of appliance beneath drawer are not obstructed and kept clean to allow ventilation for the refrigeration system to expel heat.
4. Plug your appliance into a dedicated power circuit. (Not shared with other appliances).
5. When initially loading your new product, or whenever large quantities of warm contents are placed within refrigerated storage compartment, minimize drawer openings for the next 12 hours to allow contents to pull down to compartment set temperature.
6. Maintaining a relatively full storage compartment will require less appliance run time than an empty compartment.
7. Ensure drawer closing is not obstructed by contents stored in your appliance.
8. Allow hot items to reach room temperature before placing in product.
9. Minimize drawer openings and duration of drawer openings.
10. Use the warmest temperature control set temperature that meets your personal preference and provides the proper storage for your stored contents.
11. When on vacation or away from home for extended periods, set the appliance to warmest acceptable temperature for the stored contents.
12. Set the control to the "off" position if cleaning the appliance requires the drawer to be open for an extended period of time.

OBTAINING SERVICE

If Service is Required:

- If the product is within the first year warranty period please contact your dealer or call AGA MARVEL Customer Service at 800.223.3900 for directions on how to obtain warranty coverage in your area.
- If the product is outside the first year warranty period, AGA MARVEL Customer Service can provide recommendations of service centers in your area. A listing of authorized service centers is also available at www.agamarvel.com under the service and support section.
- In all correspondence regarding service, be sure to give the service number, serial number, and proof of purchase.
- Try to have information or description of nature of the problem, how long the appliance has been running, the room temperature, and any additional information that may be helpful in quickly solving the problem.
- Table "C" is provided for recording pertinent information regarding your product for future reference.

For Your Records	
Date of Purchase	
Dealer's name	
Dealer's Address	
Dealer's City	
Dealer's State	
Dealer's Zip Code	
Appliance Serial Number	
Appliance Service Number	
Date Warranty Card Sent (Must be within 10 days of purchase).	

Table C

TROUBLESHOOTING

Before You Call for Service

If the appliance appears to be malfunctioning, read through this manual first. If the problem persists, check the troubleshooting guide below. Locate the problem in the guide and refer to the cause and its remedy before calling for service. The problem may be something very simple that can be solved without a service call. However, it may be required to contact your dealer or a qualified service technician.



WARNING

Electrocution Hazard

- Never attempt to repair or perform maintenance on the appliance until the main electrical power has been disconnected. Turning the appliance control "OFF" does not remove electrical power from the unit's wiring.
- Replace all parts and panels before operating.

Problem	Possible Cause	Remedy
Appliance not cold enough (See "Adjusting the temperature" on page 11)	• Control set too warm	• Adjust temperature colder. Allow 24 hours for temperature to stabilize.
	• Content temperature not stabilized.	• Allow temperature to stabilize for at least 24 hours.
	• Excessive usage or prolonged drawer openings.	• Airflow must not be obstructed to front grille. See "clearances" on page 4.
	• Airflow to front grille blocked.	• Adjust or replace drawer gasket.
Appliance too cold (See "Adjusting the Temperature" on page 11)	• Drawer gasket not sealing properly.	• Adjust temperature warmer. Allow 24 hours for temperature to stabilize.
	• Control set too cold	• Adjust or replace drawer gasket.
No interior light.	• Failed LED light assembly or light switch.	• Contact a qualified service technician.
Light will not go out when drawer is closed	• Drawer not activating light switch.	• Appliance not level, level appliance, (See page 4, "leveling legs")
	• Failed light switch	• Contact a qualified service technician.
Noise or Vibration	• Appliance not level	• Level appliance, see "Leveling Legs" on page 4.
	• Fan hitting tube obstruction.	• Contact a qualified service technician.
Appliance will not run.	• Appliance turned off	• Turn appliance on. See "Starting your appliance" on page 10.
	• Power cord not plugged in.	• Plug in power cord.
	• No power at outlet.	• Check house circuit.

HOUSEHOLD PRODUCT WARRANTY

Entire Product

Limited One Year Parts and Labor Warranty

AGA MARVEL warrants that it will supply all necessary parts and labor to repair or replace in the end user's home or office, any component which proves to be defective in material or workmanship, subject to the condition and exclusions stated below, for a period of one year from the date of purchase by the end user.

Additional Second Through Fifth Year

Limited Parts Only Warranty

During the four years following expiration of the one year limited warranty, AGA MARVEL will supply replacement parts for the hermetically sealed refrigeration system which consists of the compressor, condenser, drier, accumulator, bypass valve, connecting tubing and the evaporator that are proven to be defective due to workmanship or materials subject to the conditions and exclusions below.

The above warranties do not cover:

- Shipping costs of replacement parts or returned defective parts.
- Customer education or instructions on how to use the appliance.
- Any content loss due to product failure.
- Removal or installation of product.

Nor do the above warranties cover failure of this product or its components due to:

- Transportation or subsequent damages.
- Commercial use or use other than normal household or small office.
- Improper installation, misuse, abuse, accident or alteration, use of wiring not conforming to electrical codes, low or high voltages, failure to provide necessary maintenance, or other unreasonable use.

Parts or Service

Not Supplied or Designated by AGA MARVEL

The above warranties also do not apply if:

- The original bill of sale, deliver date, or serial number cannot be verified.
- Defective parts are not returned for inspection if so requested by AGA MARVEL.
- The refrigeration equipment is not in the possession of the original end use purchaser.

The warranties set forth herein are the only warranties extended by AGA MARVEL. Any implied warranties, including the implied warranty of merchantability, are limited to the duration of these express warranties. In no event shall AGA MARVEL be liable for any consequential or incidental damages or expenses resulting from breach of these or any other warranties, whether express or implied.

Some states do not allow the exclusion or limitation of consequential damages or a limitation on how long an implied warranty lasts, so the above exclusion or limitation may not apply to you. This warranty gives you specific legal rights and you may have other rights that may vary from state to state.

No person, firm, or corporation is authorized to make any other warranty or assume any other obligation for AGA MARVEL. These warranties apply only to products used in any of the fifty states of the United States and the District of Columbia.

To obtain performance of this warranty, report any defects to:

AGA MARVEL
1260 E. VanDeinse St.
Greenville MI 48838

Phone: 800.223.3900



www.agamarvel.com

AGA MARVEL

1260 E. VanDeinse St.
Greenville MI 48838

800.223.3900

41013359-EN Rev D
11/5/14

All specifications and product designs subject to change without notice. Such revisions do not entitle the buyer to corresponding changes, improvements, additions, replacements or compensation for previously purchased products.