

Model **SL-12K-A**

SCISSOR LIFT

wheel alignment model

(11000 LBS / 5000Kg Capacity)

INSTALLATION & OPERATION INSTRUCTION

(SECOND EDITION)



CE

2007. 6.

CONTENTS

Chapter 1 Introduction & Specifications -----	page 3
Chapter 2 Packing list -----	page 4
Chapter 3 Installation -----	page 5
Chapter 4 Maintenance -----	page 15
Chapter 5 Trouble shooting -----	page 16
Chapter 6 Appendix -----	page 17

INTRODUCTION

Model SL-12K-A scissor lift is used in wheel alignment, vehicle checking and maintenance for various types of cars and light trucks.

Features:

- Superior synchronization in two platforms with graceful out looking.
- The movable recesses of the front wheel turntable (optional part) and extra long rear slide plate can be fit for different models of cars.
- The pneumatic double-teeth self-locking system and the anti-explosive pipe insurance device works automatically while lowering. The sliding block is made by super-friction materials.

SPECIFICATIONS

CAPACITY:	5000Kg / 11000 LBS		
MOTOR POWER:	220V, single phase, 2.2Kw, 10A		
HYDRAULIC OIL:	10-WT hydraulic oil or Dexron III ATF oil or equals		
WORKING TEMPERATURE:	5 –40 °C		
NOISY:	≤76 db		
OVERALL LENGTH:	6320 mm	OVERALL WIDTH:	2120 mm
PLATFORM LENGTH:	5030 mm	PLATFORM WIDTH:	635 mm
MAX PLATFORM HEIGHT:	1870 mm	MIN PLATFORM HEIGHT:	180 mm
LIFTING TIME (MAX):	50 sec	LOWERING TIME (MAX):	60 sec

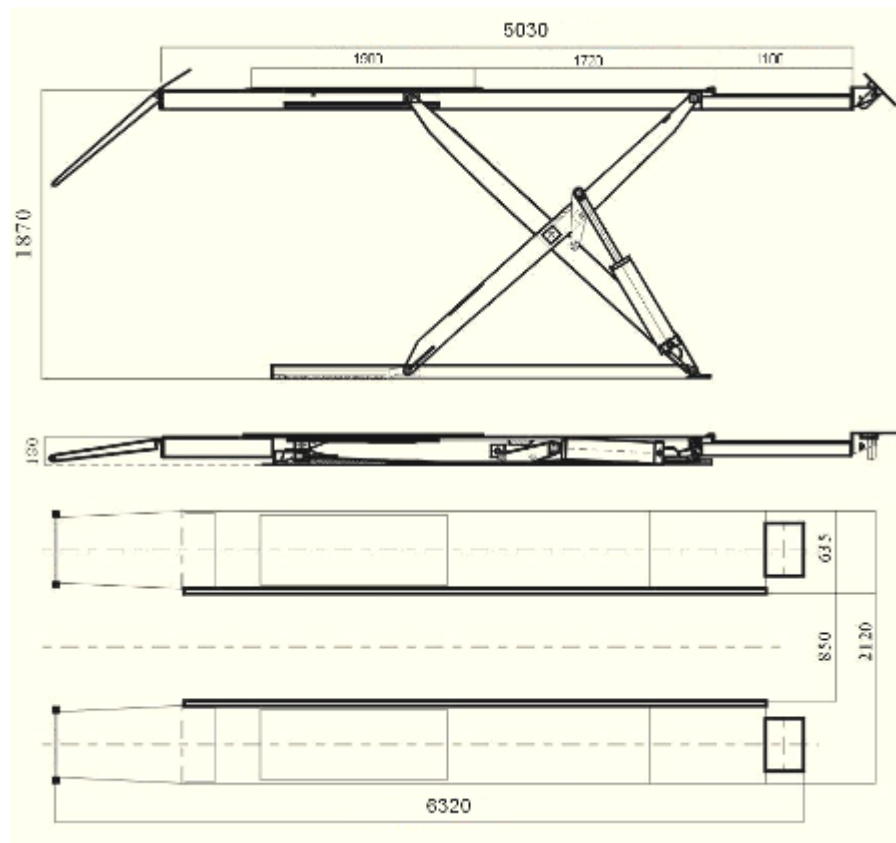

FIG. 1.

PACKING LIST

Packing number	Description	Detail information and quantity
Standard parts		
1	Oil hose and accessory	1. M16 anchor bolts * 16 sets; M18 anchor bolts * 4 sets; 2. Dia. 6*4 mm air hose * 1 set; Dia. 8*5 mm air hose * 3 meter; 3. 1.5mm wire * 5 meter. 4. Flexible steel hose * 6 meter 5. Limit switch and wire * 1 set 6. High pressure oil hose * 8 pieces. 7. User's manual 8. Dia 14mm combined seal washer * 2 pieces 9. Plastic strip * 10 pcs 10. Air hose connector dia 6, T shape, * 1 pc, 11. Air hose connector dia 6, elbow shape, * 1 pc, 12. Front stop board * 2 pcs, stop board support * 2 pcs 13. Hose cover (elbow shape) * 1 pair
2	Control cabinet	
3	Main platform	1. M16 height adjust bolts * 16 sets; 2. Height shim: 800mm * 2pcs, 150mm*2pcs.
4	Sub platform	Same as main platform above
5	Ramp	Ramp with exile * 2 pcs,
6	Hose cover	1000mm*3 pcs, 950mm*2 pcs, 750mm*2 pcs

TOOLS REQUIRED IN INSTALLATION

Rotary hammer drill or similar
 3/4" Masonry bit
 Hammer
 4 foot level
 Open-end wrench set: 7/16" – 1-1/8"
 Socket and ratchet set: 7/16" – 1-1/8"
 Hex-key / Allen wrench set
 Medium crescent wrench
 Medium pipe wrench
 Crow bar
 Chalk line
 Medium flat screwdriver
 Tape measure: 25 foot minimum
 Needle nose pliers

INSTALLATION

IMPORTANT NOTICE

These instructions must be followed to insure proper installation and operation of your lift. Failure to comply with these instructions can result in serious bodily harm and void product warranty.

Manufacturer will assume no liability for loss or damage of any kind, expressed or implied resulting from improper installation or use of this product.

PLEASE READ ENTIRE INSTRUCTION BEFORE STARTING TO ASSEMBLE THE LIFT

STEP 1: (Selecting Site) Before installing your new lift, check the following:

1. **LIFT LOCATION:** Always use architects plans when available. Check layout dimension against floor plan requirements making sure that adequate space is available(See Fig.2). The specified safety distances from walls must be 1000 mm at least. The room ceiling height must be 4000 mm at least also.
2. **FLOOR REQUIREMENTS:** The lift should be installed on a 3000 PSI concrete with little gradients. Thickness of concrete ≥ 150 mm. The leveling of whole area ≤ 10 mm.

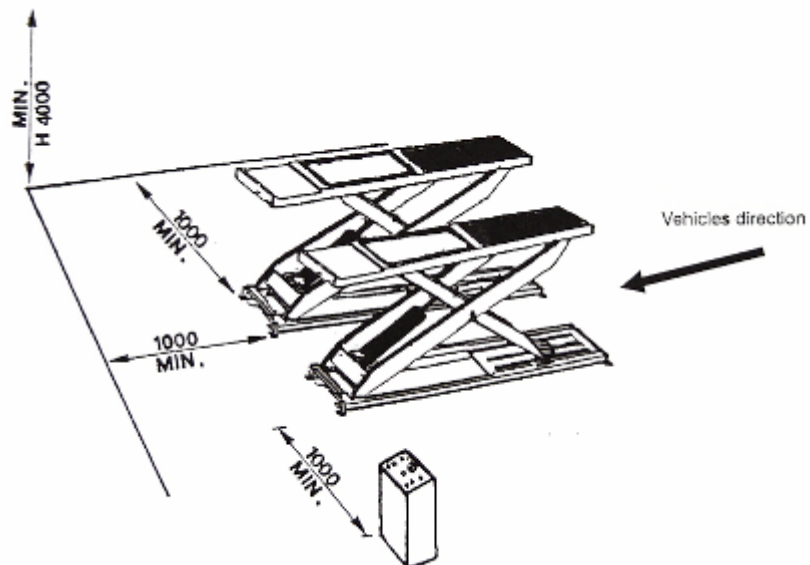

FIG. 2.

STEP 2: (Unloading and Unpacking)

1. After unloading the lift, place it near the intended installation location.
2. Remove the shipping bands and packing materials from the unit.
3. Remove the packing brackets and bolts holding the power unit. (**Do not discard bolts, they may be used in the assembly of the lift**)

STEP 3: (Site Layout)

1. Determine which side will be the approach side.
2. Now determine which side you prefer the power unit to be located on. Note that the power unit can be located on either side. It is helpful to try and locate the power unit with the driver side of the vehicle when it is loaded on the lift to save steps during operation.
3. Once a location is determined, use a carpenter's chalk line to layout a grid for the platform locations. (See Fig.1). Keep all dimensions and square within $\frac{1}{8}$ ", otherwise malfunction of the lift will occur.

- Before continuing with the installation it is helpful to get a visual look of the shop and other clearances. Also, this is a good time to drive a vehicle into the position and check for adequate clearance.

NOTE
 All models **MUST** be installed on 3000PSI concrete only confirming to the minimum requirements. New concrete must be adequately cured by at least 28 days minimum.

STEP 4: (Platform installation)

- Using forklift or crane to move the platforms to the desired location. Note: the turntable recess shall be in the front and the rolling jack wheel notch shall be inside.

Note: Put the bottom steel sheet under the frame, holes to holes.

- Check the distance between the two platforms. The platforms shall be in parallel and the diagonal of the two platforms shall be equal. (Difference less than 5 mm).

- Using forklift or crane to lift up the platform about 1000 mm as shown in Fig 3.

(Hint: Using two floor jacks to lift up the platform in two ends a little then lift the whole platform in the middle. The platform will be rested on the safety ladder)

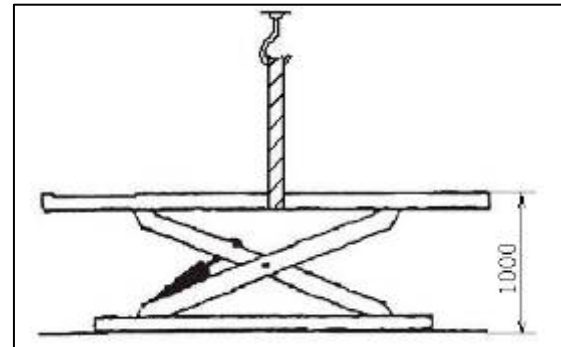

FIG. 3

- Locate the power unit to the desired position.(Fig 4 & Fig.5)



Power unit
Fig. 4

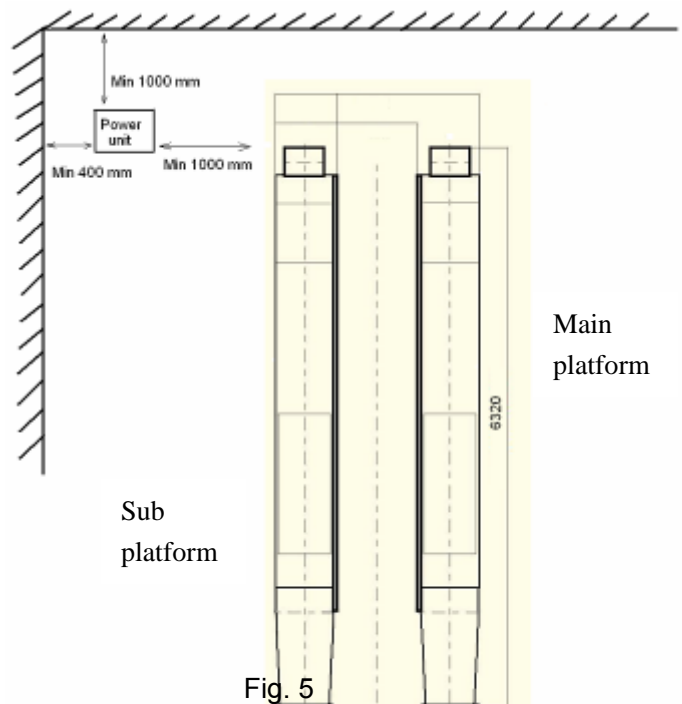
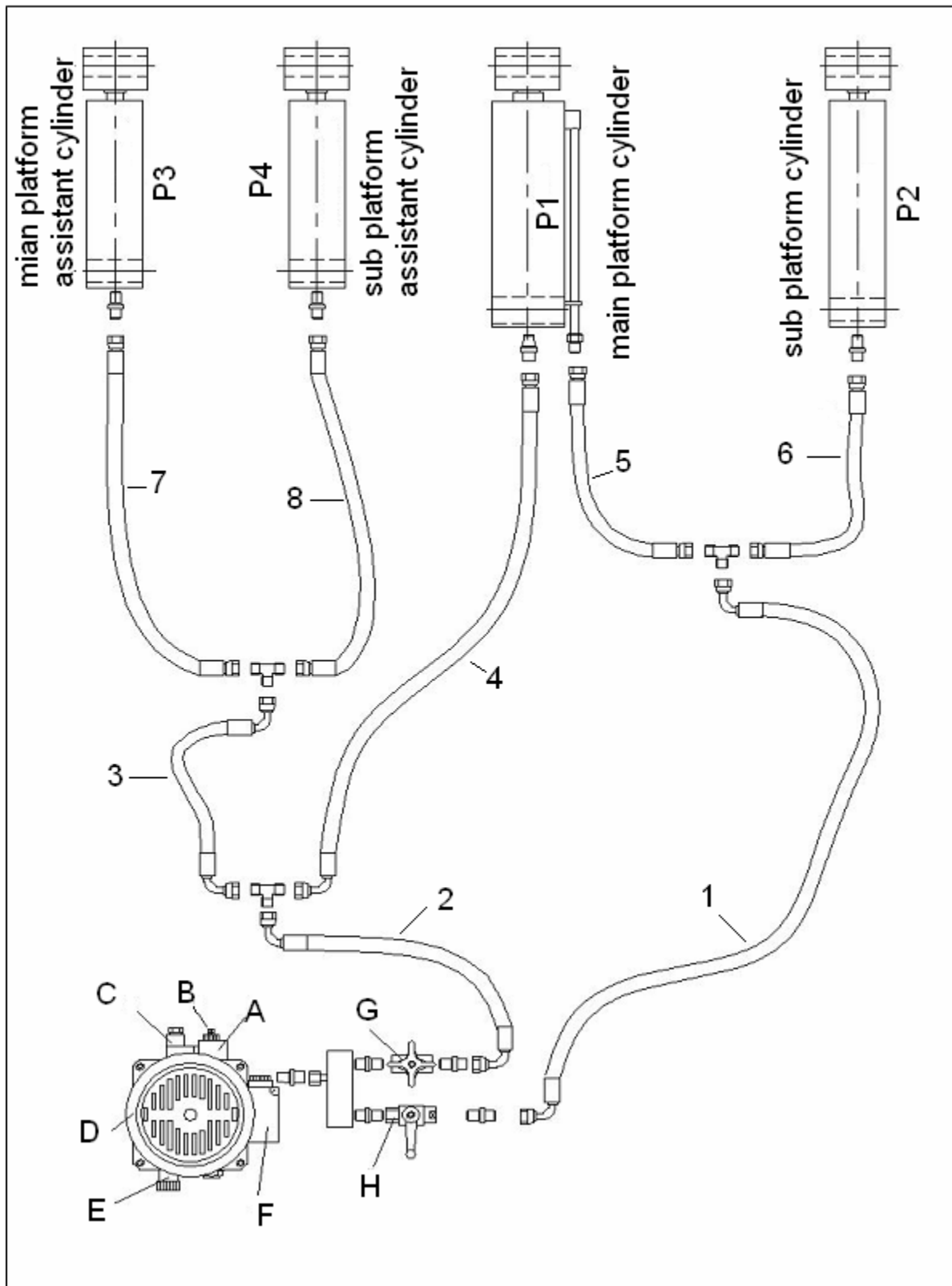

Fig. 5

5. Connecting the hydraulic hoses according to Fig. 6



Hose connection

Fig. 6

Note: Hose no. 7 and no. 8 has been connected in factory
Valve H (with handle) in this position shown is open.



Fig 7
Main cylinder connection (No. 4 and No.5).



Fig. 8
Sub cylinder connection (No. 6).

Assistant cylinder connection
(No. 7 for main assistant cylinder
No. 8 for sub assistant cylinder)
(They are all fixed by manufacturer)



Fig 9

Power unit outlet connection
(No. 1 and No. 2)



Fig. 10

6. Connecting the air hose according to Fig.11

The air hose has been connected to the safety devices on the main and sub platform already. The work in installation is to connect the hose to the power unit. (Fig 4).

Warning: the air supply shall be cut off while connecting.

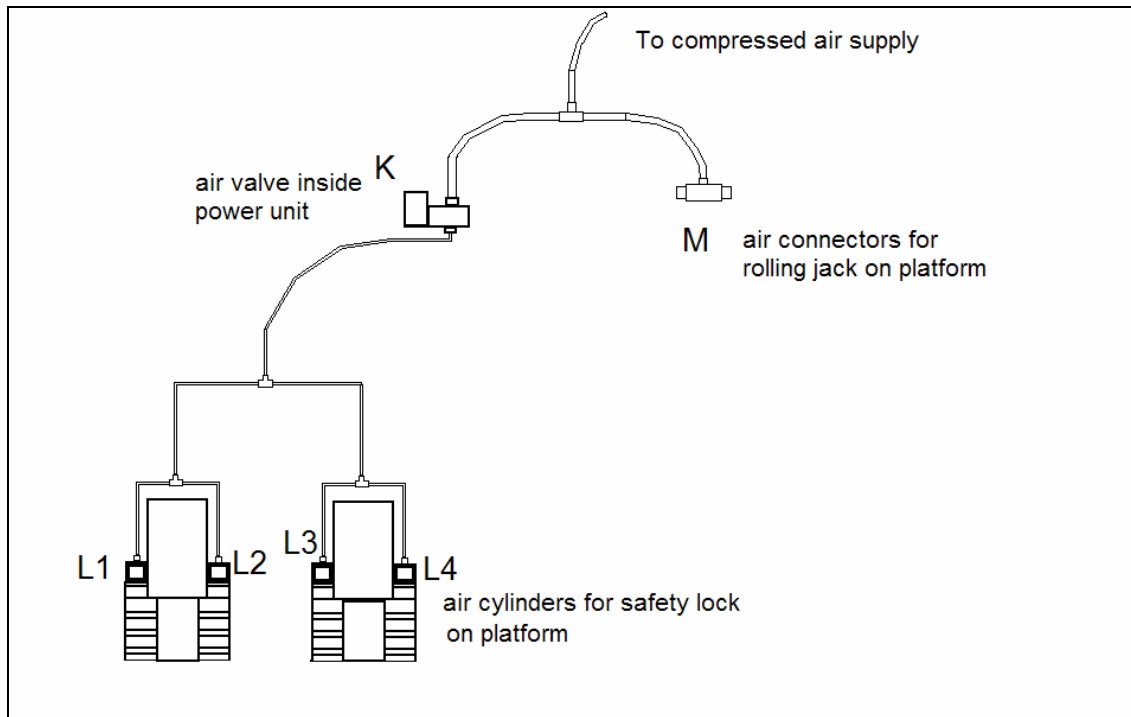

Fig. 11

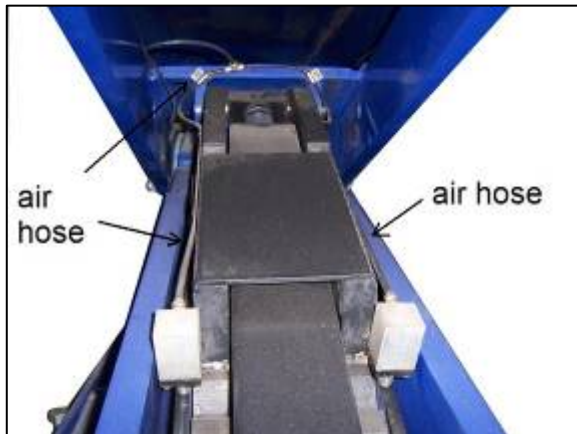
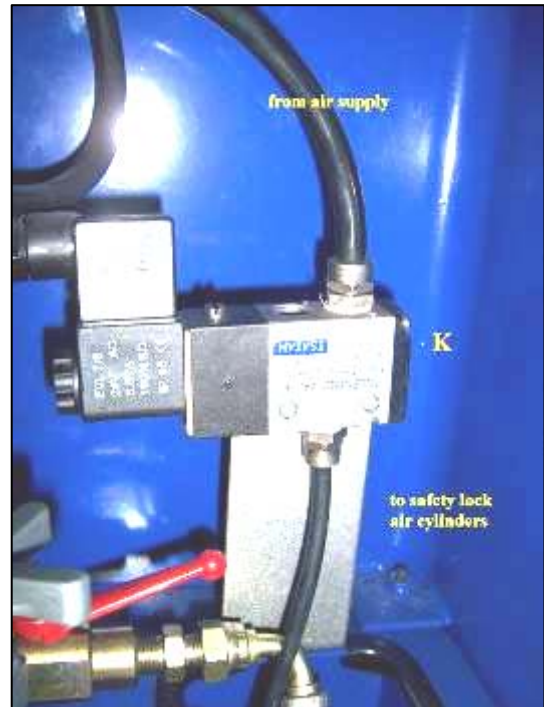

Fig. 12 (L1/L2 or L3/L4 on platforms)



3 (elec.-magnetic air valve K)



Fig. 14 (Air supply connector for rolling jack)

7. Mount the switch on the inside of the bottom frame of the main platform (Fig 15)

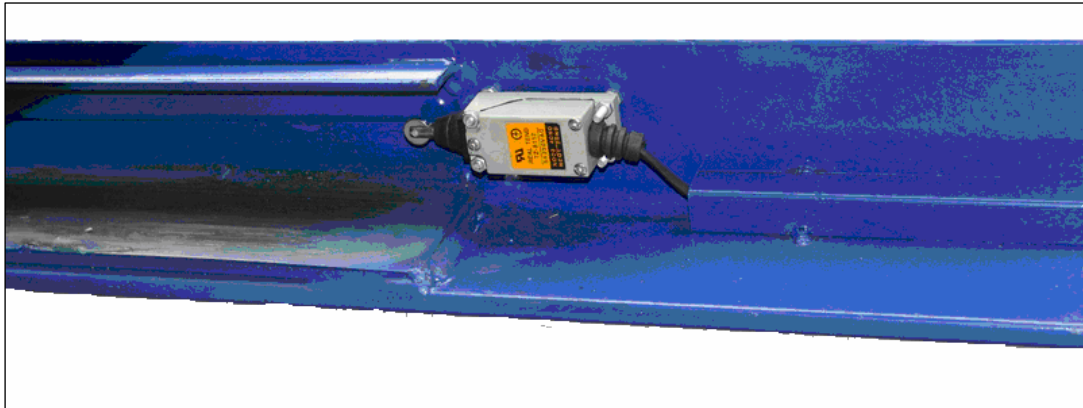

Fig. 15

8. Connecting the cables to the power unit according to Fig. 16 & 17

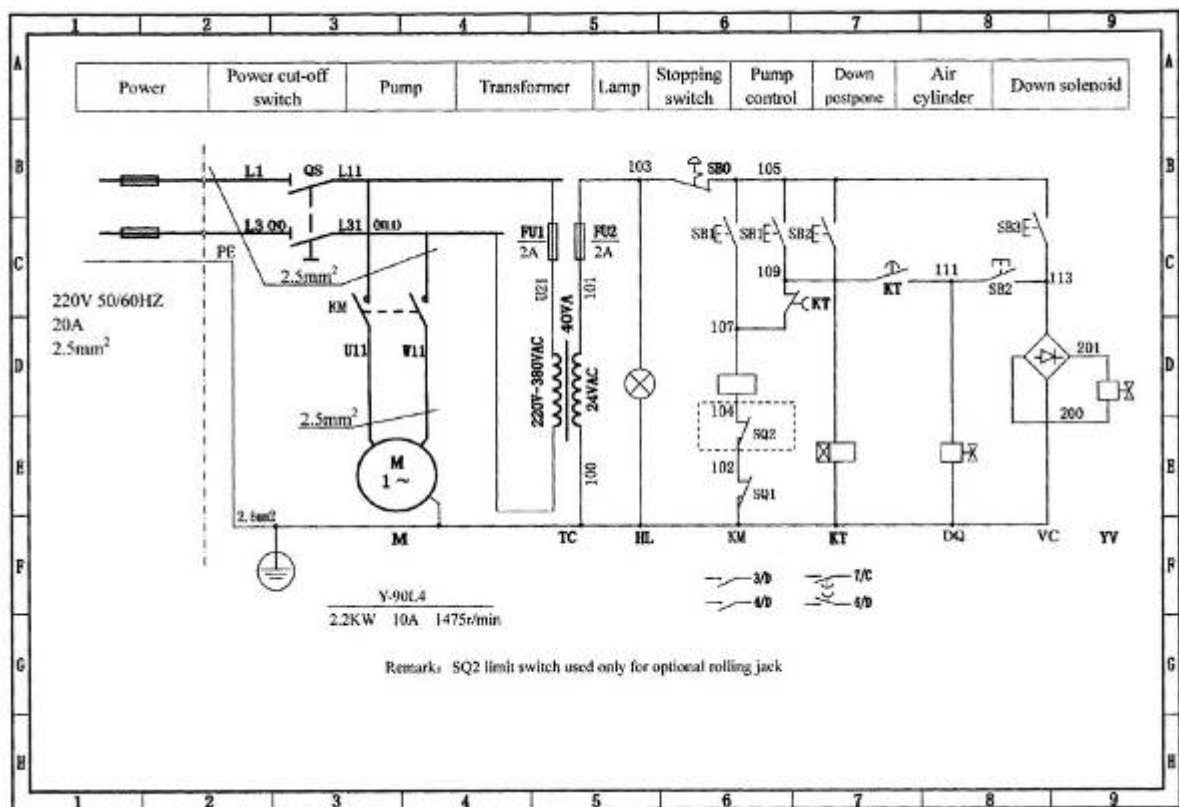

Fig.16

- QS: MAIN POWER SWITCH
- SB0: EMERGENCY BUTTON
- SB1: LIFT UP BUTTON
- SB2: LOWER DOWN BUTTON
- SB3: LOCK BUTTON
- SQ1: HEIGHT LIMIT SWITCH
- DQ: AIR VALVE (Position No.111 can be No. 109)

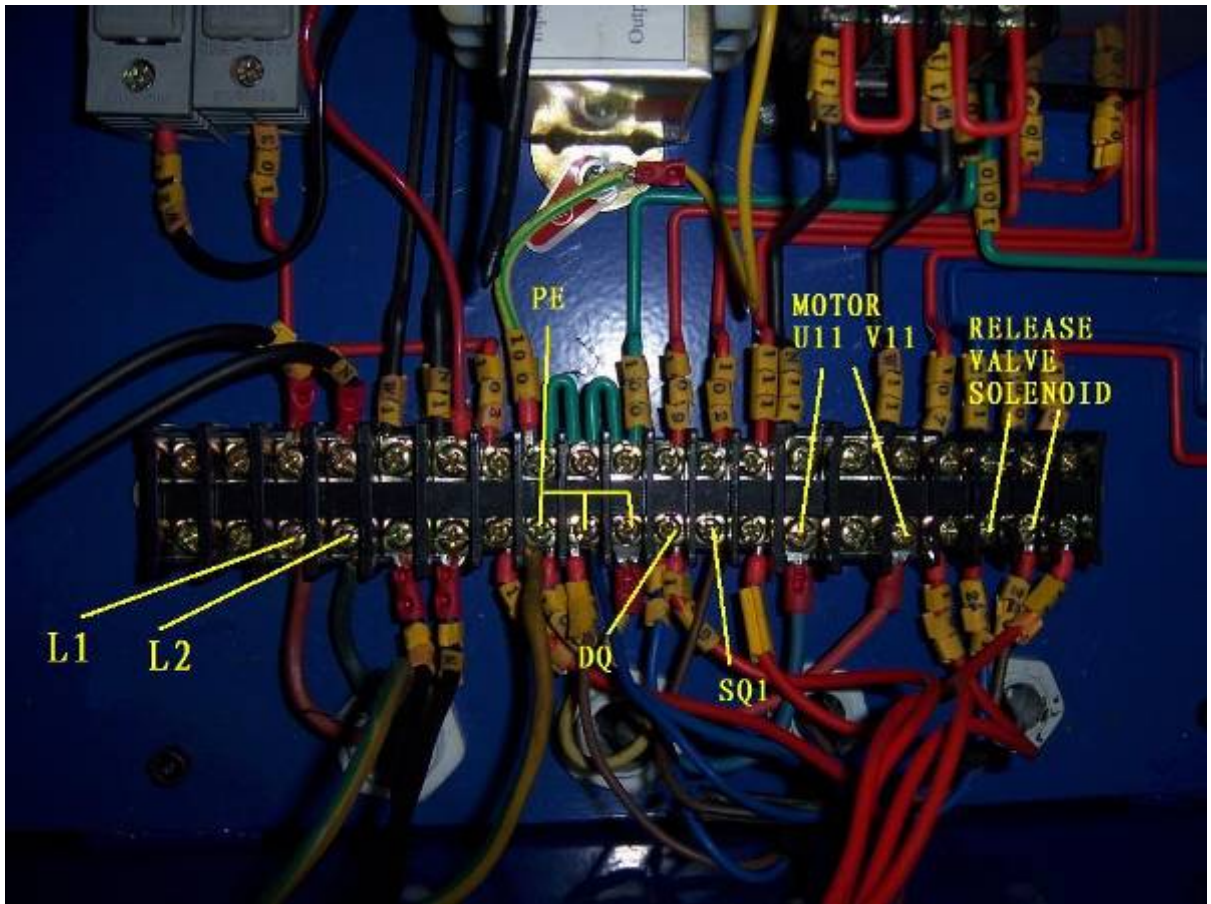

Fig. 17

WARNING: While connecting the power cable, cut off the power supply first.

STEP 5: (Platform adjustment)

1. platform longitudinal leveling



(Front end) Fig.19



(Rear end) Fig.8



Fig.20

Using the pipe level will be easy for this work. Fill the pipe with water and attach it to the front end (Fig.19) and rear end (Fig. 20) of the platform. Checking the water level, if needed, screw down the adjusting bolts to lift the platform a little then put some shims under the frame to make the platform level in whole distant. (Fig. 21). Difference ≤ 5 mm.

Note: while inserting the shims under the frame, both sides shall be considered.



Fig. 21

2. cross section

By using the level (Fig 22) or the pipe level (fig.23), it is easy to level the platform in cross section by inserting the shims under the bottom frame.

Difference ≤ 3 mm.

Note: This level work shall be done at both ends for each platform.

It is better to check the platform in longitude again after the cross leveling.



Fig. 22



Fig.23

STEP 6: (accessory mounting and anchoring)

1. Rear ramps mounting.(Fig. 24)
2. Front stops mounting. (Fig.25)
3. Hose cover mounting (Fig.26)



Fig.24

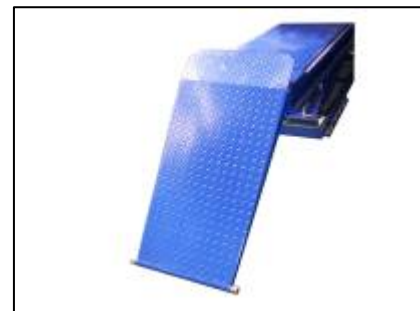

Fig.25

4. Using rotary hammer drill to dig the holes for anchors. Clean the hole then anchor it. Be sure not to move the platform during this work. (Fig.27)



Fig. 26



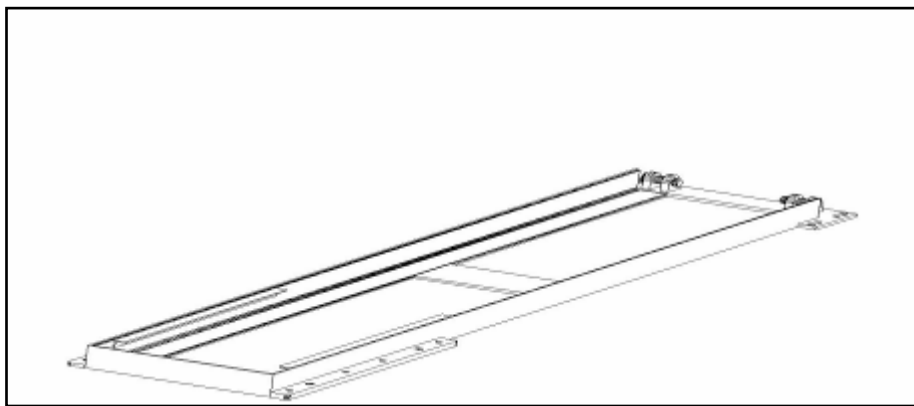

Fig.27

WARNING: Before carrying out the following steps, please check again all hoses and cables. Carefully check the power supply (220V, 1ph, 20A) and compressed air supply (6-8 bars).

STEP 7: (Platform initializing and leveling)

1. Turn on the main power switch (Fig.28) and compressed air supply valve. Open the cabinet door of the power unit on the back to find the valve “H” and “ G”.
2. Close the valve “H” by turn the handle 90 degree to be parallel to the pipe. Open the valve “G” by counter clockwise turning. (Fig. 29)
3. Press the “Lift up” button on the power unit to raise the main platform to about 1000 mm high.(Fig. 30) (f the platform is already 1000 mm high, please raise it a little more.)
4. Press the “Lower down“ button to lower the main platform to lowest position. (Fig. 31)
5. Press the “Lift up” button again to raise the main platform to 1400 mm. (Fig.32)



Fig.28



Fig. 29

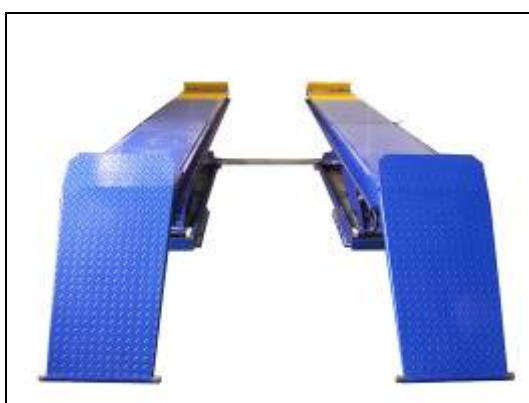

Fig. 30



Fig.31

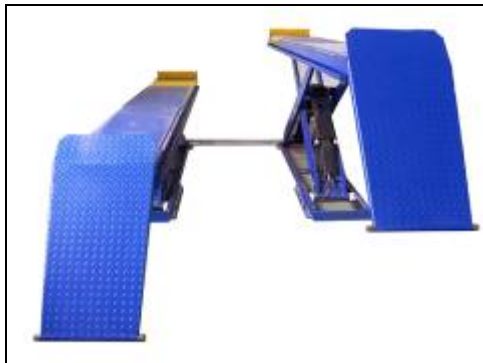
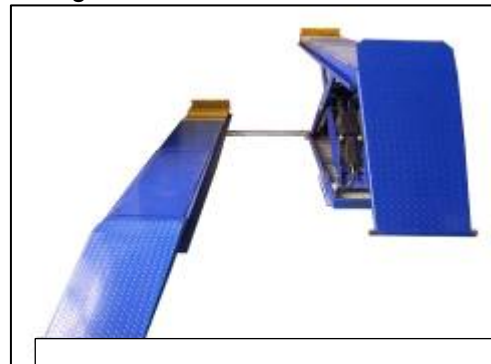

Fig. 32



Fig. 33

6. Open the valve "H". Close the valve "G" .(Fig. 33)
 7. Press the "lift up" button to raise the sub platform to about 1000 mm high.(Fig. 32)
(If the platform is already 1000 mm high, please raise it a little more.)
 8. Press the " lower down" button to lower the sub platform to the lowest position (Fig. 34)
 9. Repeat the lifting and lowering of the sub platform for 6-7 times to get the air out of the cylinders.
 10. Then lift the sub platform to the same height of the main platform. Level these two platforms using level or water pipes.(Fig. 35-36)
Difference \leq 3 mm.
 11. Close the valve "H". Open the valve "G". (Fig. 29)
 12. Press the "lift up" button to raise both platform to 1700mm high. Adjust the position of the limit switch on the bottom frame. (Fig.37) Raise up the platform to touch the limit switch to check it works.
- Note: The ceiling height shall be considered in this adjustment.



Height limit switch The lift is ready for working now.

Fig.37

MAINTENANCE

1. Daily
 - a. Check power supply cables, compressed air hoses, oil hoses before operation.
 - b. Check the voltage of the power supply and the pressure of the compressed air.
 - c. Check the parallel and leveling of the platforms.
2. Monthly

- a. Check the leveling between the platforms. If necessary, do as following steps.
 - First lift up the platforms to about 1400 mm high without loading.(Fig. 30)
 - Close the valve “G”, open the valve “ H”. (Fig.33)
 - Press the “lift up” or “lower down” button to make the sub platform same height as the main platform using level or water pipe level.(Fig 35-36)
 - Close the valve “H”, open the valve “ G”. (Fig. 29) Now the lift is ready for working.
 - b. Grease the necessary part of the lift such as sliding plate on the bottom frame, upper rolling dolly, shafts and the safety locking bars.
 - c. Check all anchor bolts on the bottom frame and tighten them up in necessary.
 - d. Chang the oil in tank after first three months or 10 hours accumulated working hours.
3. Yearly
- a. Clean the filter of the oil tank and change the oil totally with new one.
 - b. Check all parts of the lift for any possible problem.

TROUBLE SHOOTING

Fault	Possible cause	Solutions
The motor does not start although the lifting-up has been pressed.	<input type="checkbox"/> Connection of power supply cables are not correct.	Check and re-connect the cables.
	<input type="checkbox"/> The contactor (KM in Fig.16) in the circuit of the motor does not work.	If the motor starts when forcing the contactor closed down with an isolated rod, check the control circuit. If the voltage at two ends of the contactor coil is normal, replace the contactor.
	<input type="checkbox"/> The limit switch is not work.	Short-circuit terminal 10# and 0#, which are connected with the limit switch, and if the trouble disappears, check the limit switch, or replace it with a new one.
In lifting operation, the motor runs, but there is no lifting movement.	<input type="checkbox"/> The motor turns inverse.	Change the phases of the power supply cables. Or call engineer to change the connection inside the motor.
	<input type="checkbox"/> Lifting with light load is normal but not with heavy load.	The safe pressure of the over-flow valve (E in Fig 16) shall be increased by turning the knob clockwise slightly. The spool of the lowering solenoid valve (C in Fig .16) is stuck by dirt. Clean the spool.
	<input type="checkbox"/> The hydraulic oil in tank is not enough.	Add some hydraulic oil to the tank.
	<input type="checkbox"/> The valve "G" is not open.(Fig. 16)	Turn counter clockwise and open the valve "G".
When press "Lower down" button, the platform is not lowered.	<input type="checkbox"/> The safety locks are not released form the safety teeth.	First lift up the platform a little to open the safety lock then lowering it.
	<input type="checkbox"/> The safety locking pawl is not lifted.	The air pressure is not high enough to lift up the safety locking pawl. Please increase the pressure be 6-8 bar.
	<input type="checkbox"/> The solenoid air valve does not work.	If the solenoid air valve is energized, but does not open the air loop, check or replace the solenoid air valve.
	<input type="checkbox"/> The lowering solenoid valve is energized but does not work.	Check the plug and coil of the lowering solenoid valve. Check the tightness of its lock nut on the coil.
	<input type="checkbox"/> The hydraulic oil has too high viscosity or frozen, deteriorated (in Winter).	Replace with new hydraulic oil in accordance with the instruction book.
The lift lowers extremely slowly under normal loads.	The "antiknock valve" for preventing oil pipe burst is blocked.	Shut off air supply and thus lock the safety pawl of the lift Remove the "antiknock valve" from the oil supply hole at the bottom of the cylinder, then clean the "antiknock valve".
The platforms are not synchronous and not in the same height.	<input type="checkbox"/> The air in the oil cylinder is not vent completely.	Refer to STEP 7 in INSTALLATION.
	<input type="checkbox"/> Oil leakage on oil pipe or at its connections.	Tighten oil pipe connectors or replace oil seals then initialize the system and do leveling again.
	<input type="checkbox"/> The valve "H" can not be closed totally.	Replace valve "H", and then level the platforms.
Noisy lifting and lowering.	<input type="checkbox"/> Lubrication is not enough.	Lubricate all hinges and motion parts (including piston rod) with oil or grease.
	<input type="checkbox"/> The base or the lift frame is twisted.	Again level the platforms and make the bottom frames stable.

APPENDIX

1. PARTS DRAWING

