



ADLINK
TECHNOLOGY INC.

RTV Series
Multi-Channel Real-Time Video
Frame Grabber Series
User's Manual

Manual Rev. 2.00
Revision Date: October 26, 2004
Part No: 50-18001-102



Recycled Paper

Advance Technologies; Automate the World.



Copyright 2004 ADLINK TECHNOLOGY INC.

All Rights Reserved.

The information in this document is subject to change without prior notice in order to improve reliability, design, and function and does not represent a commitment on the part of the manufacturer.

In no event will the manufacturer be liable for direct, indirect, special, incidental, or consequential damages arising out of the use or inability to use the product or documentation, even if advised of the possibility of such damages.

This document contains proprietary information protected by copyright. All rights are reserved. No part of this manual may be reproduced by any mechanical, electronic, or other means in any form without prior written permission of the manufacturer.

Trademarks

Product names mentioned herein are used for identification purposes only and may be trademarks and/or registered trademarks of their respective companies.

Getting Service from ADLINK

Customer Satisfaction is top priority for ADLINK Technology Inc. Please contact us should you require any service or assistance.

ADLINK TECHNOLOGY INC.

Web Site: <http://www.adlinktech.com>
 Sales & Service: Service@adlinktech.com
 TEL: +886-2-82265877
 FAX: +886-2-82265717
 Address: 9F, No. 166, Jian Yi Road, Chungho City, Taipei, 235 Taiwan

Please email or FAX this completed service form for prompt and satisfactory service.

Company Information	
Company/Organization	
Contact Person	
E-mail Address	
Address	
Country	
TEL	FAX:
Web Site	
Product Information	
Product Model	
Environment	OS: M/B: CPU: Chipset: Bios:

Please give a detailed description of the problem(s):

Table of Contents

Table of Contents	i
List of Tables	iii
List of Figures	iv
1 Introduction	1
1.1 Features.....	1
Image Acquisition	1
I/O Lines	2
Watchdog Timer	2
Supported Software	2
1.2 Applications	3
1.3 System Requirements	3
1.4 RTV-24 Benchmarks	4
PCI-33 Platform	4
PCI-X Platform	5
2 Hardware Reference	7
2.1 RTV series	7
RTV-24 Specifications	7
RTV-E4 Extension board (Optional)	13
RTV-I4 Isolation GPIO board (Optional)	14
2.2 cRTV series	18
cRTV-24 Specifications	18
cRTV-44 Specifications	21
2.3 PMC-RTV series.....	25
PMC-RTV21 Specifications	25
PMC-RTV21G Specifications	28
3 Installation Guide	31
3.1 Hardware Installation	31
RTV Series	31
cRTV Series	32
PMC-RTV Series	35
RTV-E4 Extension board (Optional)	35
RTV-I4 Extension board (Optional)	36
3.2 Driver Installation	37

WDM Driver Installation	37
Linux Driver Installation	52
4 ViewCreator Utility	57
4.1 Overview	57
4.2 Component Description	58
4.3 Operation Theory	59
Continuous Grab	59
Video Image Configuration	59
Video Adjustments	60
Save image file	60
Tools	60
5 Function Library.....	63
5.1 List of Functions.....	63
5.2 C/C++ Programming Library	64
5.3 System Functions	65
5.4 Configuration Functions	71
5.5 Image Grabbing	81
5.6 GPIO & EEPROM Functions	86
5.7 Callback & Thread Functions.....	93
5.8 Watchdog Timer.....	99
5.9 Software Trigger	102
5.10 Frame Buffer.....	105
6 Appendix.....	111
6.1 Glossary.....	111
6.2 Standards Compliance.....	113
Warranty Policy	115

List of Tables

Table 1-1: RTV Series Acquisition Speed	1
Table 1-2: PCI-33 4CIF Benchmarks	4
Table 1-3: PCI-33 CIF Benchmarks	4
Table 1-4: PCI-33 QCIF Benchmarks	4
Table 1-5: PCI-X 4CIF Benchmarks	5
Table 1-6: PCI-X CIF Benchmarks	5
Table 1-7: PCI-X QCIF Benchmarks	5
Table 2-1: GPIO Characteristics	7
Table 2-2: RTV Video Inputs	9
Table 2-3: Channel Extension Video Input (CN2)	10
Table 2-4: Channel Extension Video Input (CN3)	10
Table 2-5: Channel Extension Video Input (CN5)	11
Table 2-6: GPIO (CN8)	11
Table 2-7: GPIO (CN9)	12
Table 2-8: Watchdog Timer	12
Table 2-9: Channel Extension Video Input (CN11)	13
Table 2-10: Relay Jumper Settings	15
Table 2-11: STRG Jumper Settings	16
Table 2-12: RTV-I4 GPIO (CN1) <--> RTV-24 GPIO (CN8)	17
Table 2-13: RTV-I4 GPIO (CN2) <--> RTV-24 GPIO (CN9)	17
Table 2-14: D-sub 25-pin Connector	18
Table 2-15: cRTV Video Inputs	20
Table 2-16: Channel Extension Video Input (CN8)	20
Table 2-17: GPIO Characteristics	21
Table 2-18: cRTV Video Inputs	23
Table 2-19: Channel Extension Video Input (CN8)	23
Table 2-20: GPIO 0 Pinout	24
Table 2-21: GPIO 1 Pinout	24
Table 2-22: GPIO Characteristics	25
Table 2-23: Video Input	27
Table 2-24: GPIO Pinout	27
Table 2-25: GPIO Characteristics	28
Table 2-26: Video Input	29
Table 2-27: GPIO Pinout	29
Table 5-1: List of Functions	63
Table 5-2: C/C++ Data Types	64
Table 5-3: Pixel Data	105

List of Figures

Figure 2-1: Trigger Signal Waveform.....	8
Figure 2-2: RTV-24 Appearance.....	8
Figure 2-3: RTV-E4 Appearance	13
Figure 2-4: RTV-I4 Appearance.....	14
Figure 2-5: Relay Address Jumpers	15
Figure 2-6: STRG Address Jumpers.....	16
Figure 2-7: cRTV-24 Appearance	19
Figure 2-8: cRTV-44 Appearance	22
Figure 2-9: PMC-RTV21 Appearance.....	26
Figure 2-10: PMC-RTV21 Video Input & GPIO.....	26
Figure 3-1: RTV-24 Installation	31
Figure 3-2: cRTV-24 (3U cPCI).....	33
Figure 3-3: cRTV-44 (6U cPCI).....	34
Figure 3-4: RTV-E4 Attachment.....	36
Figure 3-5: RTV-I4 Attachment	37
Figure 4-1: ViewCreator Main Screen.....	58
Figure 5-1: Video Frame	72

1 Introduction

The RTV series acquisition board is designed without compromise for security and video surveillance applications as a PC-based multiple channel digital video recorder.

This 32-bit/64bit, 33MHz/66MHz PCI/cPCI/PMC bus frame grabber simultaneously captures four video analog streams in real-time. It accepts standard composite color (PAL, NTSC) or monochrome video formats (CCIR, EIA).

The square-pixel and broadcast resolutions are programmable (640 x 480 or 768 x 576). Before images are transferred into the PC's memory, the resolution can be scaled down using selectable ratios.

Arbitrary cropping to regions of interest is supported. The RTV series generates bitmaps in all popular color formats such as RGB.

System integrators will benefit from a watchdog timer for fault-tolerant applications and from the easy-to-use standard connectors.

1.1 Features

Image Acquisition Acquisition Speed

NTSC	1 Camera	2 Cameras	3 Cameras	4 Cameras	8 Cameras
Fields	60	120	180	240	240
Frames	30	60	90	120	120
PAL	1 Camera	2 Cameras	3 Cameras	4 Cameras	8 Cameras
Fields	50	100	150	200	200
Frames	25	50	75	100	100

Table 1-1: RTV Series Acquisition Speed

Note: The PMC-RTV21 is capable of only up to 30 frames (60 fields) in total acquisition speed.

Color Image

The color video format is compatible with the following composite video input formats: NTSC-M, NTSC-Japan, PCL-B, PAL-D, PAL-G, PAL-H, PAL-I, PAM-M, PAL-N, and SECAM

Monochrome Image

The monochrome video acquisition is compatible with CCIR and EIA (RS-170)

Optional Scaling

Optional scaling of acquired image or portions of an image.

- ▶ Acquisition of a programmable area of interest.
- ▶ Scaling of the image (down to 1:16).
- ▶ Adjustment of hue (for NTSC signals), contrast (0 to 200%), brightness and saturation (0 to 200% for U and V signals).
- ▶ Automatic chrominance gain control.

I/O Lines

The RTV series is fitted with TTL compatible I/O lines protected against overloads and electrostatic discharges. Each line may be configured as an input or output. They can be used to trigger acquisition or report alarm signals.

Watchdog Timer

A hardware watchdog is available on the RTV-24 that is able to monitor PC application operation and will automatically reset the PC after a programmable inactivity time-out. This ensures reliable operation of remote systems.

Supported Software

WDM driver

The drivers support VC++ / VB / Delphi / C++ Builder programming under Windows NT/98/2000/XP. DLLs and reference sample programs are provided.

ViewCreator

The package will assist in initial test and functional evaluation.

AngeloLVIEW - Angelo-LVIEW is fully compatible with LabView™ 6.0 and above and it provides a full set of VIs that can be used with the Angelo RTV series (RTV-24, cRTV-24, cRTV-44 and PMC-RTV21/G). VIs for Windows 98/NT/2000/XP operation systems and LabView™ sample programs are provided for users' reference.

1.2 Applications

- ▶ PC Based Surveillance System
- ▶ Digital Video Recorder (DVR)
- ▶ Factory Monitoring System
- ▶ Machine Vision Inspection System
- ▶ Scientific Research Instrumentation
- ▶ Medical Research Instrumentation

1.3 System Requirements

The minimum system requirements for 4-CH real-time NTSC*/PAL** color image acquisition are:

- ▶ Platform: Pentium 4, 2.4GHz CPU, 256MB DDRAM above.
- ▶ VGA display: AGP 4X or above (VIA or SiS VGA chipset **NOT** recommended).
- ▶ Display setting: 800 x 600 resolution or above, 16-bit color or above.
- ▶ OS: if using Windows 2000, please upgrade to Service Pack 4.0 or above.

Note: Lower system configurations will lower acquisition performance.

Note: Please refer to section 1.4 RTV-24 Benchmark for the performance issues due to PCI bus bandwidth limitations.

* NTSC real-time color images – Provides 640 x 480 pixel image resolution at the RGB 16-bit color format. Each channel acquires 30 frames per second with 4-CH totaling up to 120 frames per second.

** PAL real-time color images – Provides 768 x 576 pixel image resolution at the RGB 16-bit color format. Each channel acquires

25 frames per second with 4-CH totaling up to 100 frames per second.

1.4 RTV-24 Benchmarks

PCI-33 Platform

- ▶ SBC: ADLINK NuPRO-842
- ▶ CPU: Intel Pentium 4, 2.4GHz
- ▶ Memory: DDR266 256MB
- ▶ PCI Bus: 32-bit, 33MHz
- ▶ VGA: AGP 4X
- ▶ OS: Windows 2000/SP4

Image Format	RGB16, 4CIF(640*480)				RGB24, 4CIF(640*480)			
Channels	1	2	3	4	1	2	3	4
Real-time*	O	O	O	O	O	O	O	X
Frame Rate (f/s)	30	30	30	30	30	30	30	-
CPU Usage (%)	27	28	44	61	20	35	60	-

Table 1-2: PCI-33 4CIF Benchmarks

Image format	RGB16, CIF (320*240)										RGB24, CIF (320*240)						
Channels	1	2	3	4	5	6	7	8	12	1	2	3	4	5	6	7	
Real-time*	O	O	O	O	O	O	O	O	X	O	O	O	O	O	O	X	
Frame Rate (f/s)	30	30	30	30	30	30	30	30	-	30	30	30	30	30	30	-	
CPU Usage (%)	6	9	13	17	23	28	31	36	-	8	11	16	25	27	31	-	

Table 1-3: PCI-33 CIF Benchmarks

Image Format	RGB16, QCIF (160*120)										RGB24, QCIF (160*120)										
Channels	1	2	3	4	5	6	7	8	12	16	1	2	3	4	5	6	7	8	12	16	
Real-time*	O	O	O	O	O	O	O	O	O	O	O	O	O	O	O	O	O	O	O	O	O
Frame Rate (f/s)	30	30	30	30	30	30	30	30	30	30	30	30	30	30	30	30	30	30	30	30	30
CPU Usage (%)	8	9	8	8	8	9	9	11	16	22	6	6	8	9	9	9	13	14	19	26	

Table 1-4: PCI-33 QCIF Benchmarks

* Real-time:

- ▶ “O” - All channel images can be captured in real-time with good image quality.
- ▶ “X” - All channel images will begin having data loss.

PCI-X Platform

- ▶ SBC: ADLINK NuPRO850
- ▶ CPU: Intel Pentium 4, Hyper Threading Disable
- ▶ Memory: DDR266 1GB
- ▶ PCI-X Bus: 32-bit, 66MHz
- ▶ VGA: AGP 8X
- ▶ OS: Windows 2000/SP4

Image Format	RGB16, 4CIF(640*480)									RGB24, 4CIF(640*480)					
Channel	1	2	3	4	5	6	7	8	9	1	2	3	4	5	6
Real-time*	O	O	O	O	O	O	O	O	X	O	O	O	O	O	X
Frame Rate (f/s)	30	30	30	30	30	30	30	30	-	30	30	30	30	30	-
CPU Usage (%)	13	14	19	23	25	28	32	35	-	9	16	22	28	28	-

Table 1-5: PCI-X 4CIF Benchmarks

Image Format	RGB16, CIF(320*240)										RGB24, CIF(320*240)										
Channels	1	2	3	4	5	6	7	8	12	16	1	2	3	4	5	6	7	8	12	13	
Real-time*	O	O	O	O	O	O	O	O	O	O	O	O	O	O	O	O	O	O	O	O	X
Frame Rate (f/s)	30	30	30	30	30	30	30	30	30	30	30	30	30	30	30	30	30	30	30	30	-
CPU Usage (%)	6	8	11	11	13	14	16	17	23	28	8	8	9	13	14	16	19	20	28	28	-

Table 1-6: PCI-X CIF Benchmarks

Image Format	RGB16, QCIF (160*120)										RGB24, QCIF (160*120)										
Channels	1	2	3	4	5	6	7	8	12	16	1	2	3	4	5	6	7	8	12	16	
Real-time*	O	O	O	O	O	O	O	O	O	O	O	O	O	O	O	O	O	O	O	O	O
Frame Rate (f/s)	30	30	30	30	30	30	30	30	30	30	30	30	30	30	30	30	30	30	30	30	30
CPU Usage (%)	5	5	5	6	6	6	6	8	9	12	5	5	6	6	6	8	9	9	13	16	16

Table 1-7: PCI-X QCIF Benchmarks

* Real-time:

- ▶ “O” - All channel images can be captured in real-time with good image quality.
- ▶ “X” - All channel images will begin having data loss.

2 Hardware Reference

2.1 RTV series

RTV-24 Specifications

Video Input

- ▶ Four composite video color digitizers
- ▶ Video input interface: Four composite BNC connectors
- ▶ Coaxial cable suggested

Channel Extension

- ▶ Expandable to up to 16 channels
- ▶ Channel extension interface:
 - ▷ 10-pin ribbon cable to on-board 10-pin header connector for channel extension, each header adds 4 video inputs channels
 - ▷ Three 10-pin header connectors on-board

General Purpose I/O Lines

- ▶ All I/Os are TTL compatible and support 4 inputs, 4 outputs, and 4 soft trigger lines
- ▶ GPIO interface:
 - ▷ Two 10-pin header connectors on-board
 - ▷ The I/O lines are internally pulled up and have the following characteristics:

Voltage	MIN	MAX
Input high voltage (5 μ A)	2.0V	5.25V
Input low voltage (-5 μ A)	0.0V	0.80V
Output high voltage (-1.0mA)	5.0V	-
Output low voltage (100.0mA)	-	0.5V

Table 2-1: GPIO Characteristics

- ▶ Watch Dog Timer
- ▶ For monitoring applications and will reset the PC after a programmable inactivity time-out.

- ▶ Interface: 2-pin header
- 4-channel software trigger output**
- ▶ 4-channels programmable trigger scale ($60\mu\text{s} - 16\text{ms}$)

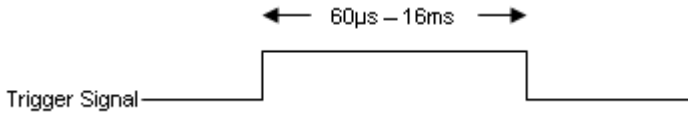

Figure 2-1: Trigger Signal Waveform

User EEPROM

- ▶ Includes 1kbit available EEPROM

Form Factor

- ▶ 32-bit, 33/66MHz PCI half-size board

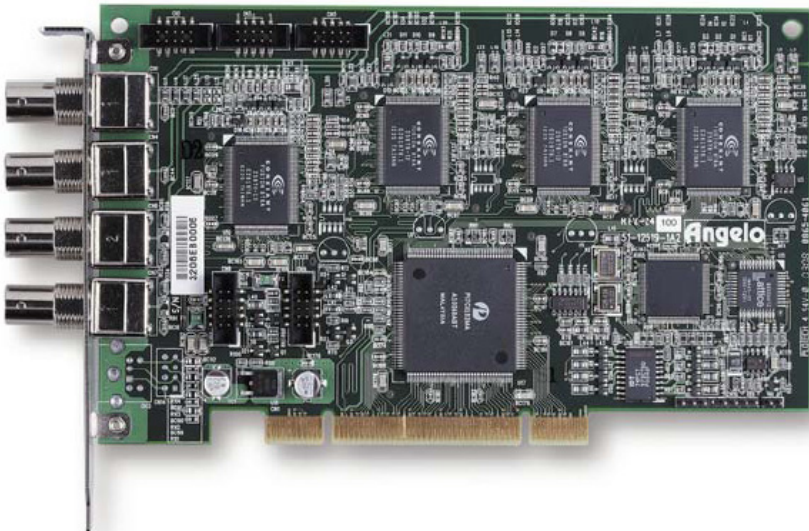

Figure 2-2: RTV-24 Appearance

RTV-24 Standard Accessories

- ▶ Watchdog reset cable
- ▶ GPIO bracket
- ▶ User Manual
- ▶ All in One CD

RTV-24 Connectors & Pin Definitions





Connector	Definition
	Video IN – CH 0
	Video IN – CH 1
	Video IN – CH 2
	Video IN – CH 3

Table 2-2: RTV Video Inputs



PIN	Function	PIN	Function
1	GND	2	CH4 video in
3	CH5 video in	4	GND
5	GND	6	CH6 video in
7	CH7 video in	8	GND
9	GND	10	GND

Table 2-3: Channel Extension Video Input (CN2)

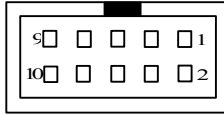
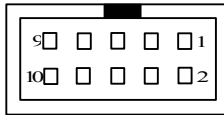

PIN	Function	PIN	Function
1	GND	2	CH8 video in
3	CH9 video in	4	GND
5	GND	6	CH10 video in
7	CH11 video in	8	GND
9	GND	10	GND

Table 2-4: Channel Extension Video Input (CN3)

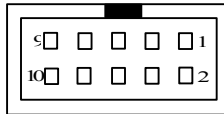

PIN	Function	PIN	Function
1	GND	2	CH12 video in
3	CH13 video in	4	GND
5	GND	6	CH14 video in
7	CH15 video in	8	GND
9	GND	10	GND

Table 2-5: Channel Extension Video Input (CN5)

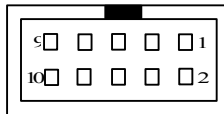

PIN	Function	PIN	Function
1	IN0 (External interrupt)	2	GND
3	OUT0	4	Software Trigger 0
5	IN1 (External interrupt)	6	Software Trigger 1
7	OUT1	8	+5V
9	GND	10	--

Table 2-6: GPIO (CN8)

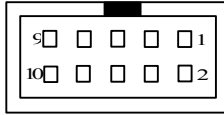

PIN	Function	PIN	Function
1	IN2 (External interrupt)	2	GND
3	OUT0	4	Software Trigger 2
5	IN3 (External interrupt)	6	Software Trigger 3
7	OUT1	8	+5V
9	GND	10	--

Table 2-7: GPIO (CN9)

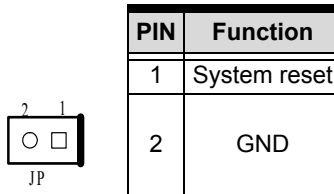

PIN	Function
1	System reset
2	GND

Table 2-8: Watchdog Timer

RTV-E4 Extension board (Optional)



Figure 2-3: RTV-E4 Appearance

RTV-E4 Connectors & Pin Definitions

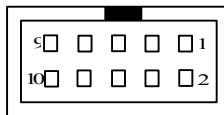

PIN	Function	PIN	Function
1	GND	2	CH4 video in
3	CH5 video in	4	GND
5	GND	6	CH6 video in
7	CH7 video in	8	GND

Table 2-9: Channel Extension Video Input (CN11)

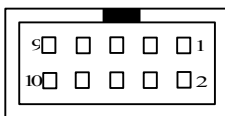

PIN	Function	PIN	Function
9	GND	10	GND

Table 2-9: Channel Extension Video Input (CN11)

RTV-I4 Isolation GPIO board (Optional)

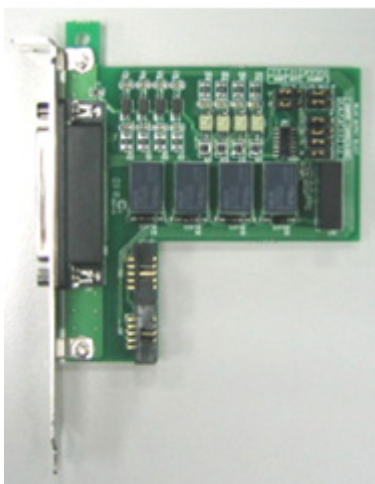

Figure 2-4: RTV-I4 Appearance

RTV-I4 Connectors & Pin Definitions

Relay output signal select:

- ▶ Relay output types: Normal open or Normal closed
- ▶ Signal names: RY1, RY2, RY3, RY4
- ▶ Jumper addresses J5, J6, J7, J8
- ▶ Type select: Normal open: 2-3, Normal close: 1-2



Normal Open	Normal Closed
	
<p>1 3</p>	<p>1 3</p>

Table 2-10: Relay Jumper Settings

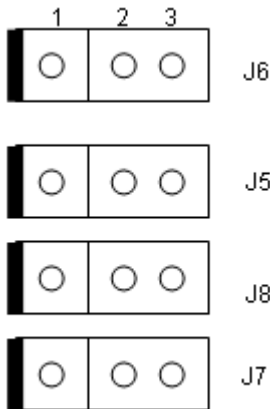

Figure 2-5: Relay Address Jumpers

Relay I/O voltage requirements

- ▶ Input: +5V to +24V
- ▶ Output: AC: 0.5A/125V, DC: 1A/30V or 0.3A/100V

STRG output signal select:

- ▶ STRG output signal types: Active high or Active low
- ▶ Signal names: STRG_OUT1, STRG_OUT2, STRG_OUT3, STRG_OUT4
- ▶ Jumper addresses: J1, J2, J3, J4
- ▶ Trigger output voltage: 0V to +5V
- ▶ Type select: Active high =>2-3, Active low =>1-2



Active High	Active Low
 1 3	 1 3

Table 2-11: STRG Jumper Settings

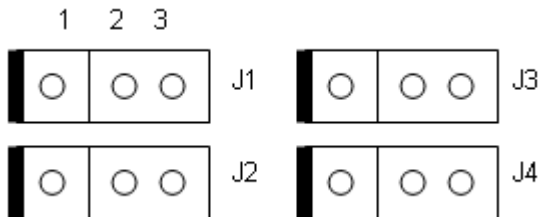
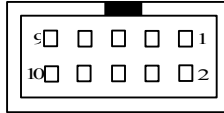

Figure 2-6: STRG Address Jumpers

2R10P Input Pin Header Definitions



PIN	Function	PIN	Function
1	GPIO Input 1	2	GND
3	GPIO Output 1	4	PORT1 STRG Output
5	GPIO Input 2	6	PORT2 STRG Output
7	GPIO Output 2	8	VCC
9	GND	10	--

Table 2-12: RTV-I4 GPIO (CN1) <--> RTV-24 GPIO (CN8)

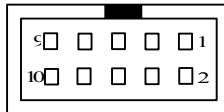

PIN	Function	PIN	Function
1	GPIO Input 3	2	GND
3	GPIO Output 3	4	PORT3 STRG Output
5	GPIO Input 4	6	PORT4 STRG Output
7	GPIO Output 4	8	VCC
9	GND	10	--

Table 2-13: RTV-I4 GPIO (CN2) <--> RTV-24 GPIO (CN9)

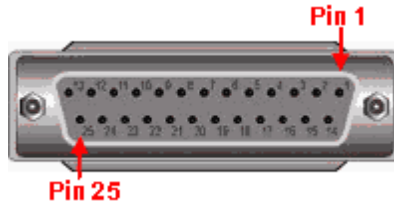

PIN	Signal	PIN	Signal
1	DI1	14	RY3_COM
2	DI1_COM	15	RY4
3	DI2	16	RY4_COM
4	DI2_COM	17	STRG_OUT1
5	DI3	18	STRG_OUT2
6	DI3_COM	19	STRG_OUT3
7	DI4	20	STRG_OUT4
8	DI4_COM	21	STRG_GND
9	RY1	22	STRG_GNG
10	RY1_COM	23	NC
11	RY2	24	NC
12	RY2_COM	25	NC
13	RY3	26	

Table 2-14: D-sub 25-pin Connector

2.2 cRTV series

cRTV-24 Specifications

Video Input

- ▶ Four composite video color digitizers
- ▶ Video input interface: Four composite BNC connectors
- ▶ Channel status report LED
- ▶ Coaxial cable recommended

Channel Extension

- ▶ Expandable to up to 8 channels
- ▶ Channel extension interface
 - ▷ 10-pin ribbon cable to on-board 10-pin header connector for channel extension, each header adds 4 video inputs channels

User EEPROM

- ▶ Includes 1kbit usable EEPROM

Form Factor

- ▶ 32/64bit, 33/66MHz, 3U Compact PCI board



Figure 2-7: cRTV-24 Appearance

cRTV-24 Standard Accessories

- ▶ User Manual
- ▶ All in One CD





Connector	Definition
	CH0 (Channel 0 BNC)
	CH1 (Channel 1 BNC)
	CH2 (Channel 2 BNC)
	CH3 (Channel 3 BNC)

Table 2-15: cRTV Video Inputs



PIN	Function	PIN	Function
1	GND	2	CH4 video in
3	CH5 video in	4	GND
5	GND	6	CH6 video in
7	CH7 video in	8	GND
9	GND	10	GND

Table 2-16: Channel Extension Video Input (CN8)

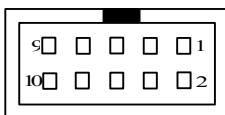
cRTV-44 Specifications

Video Input

- ▶ Four composite video color digitizers
- ▶ Video input interface: Four composite BNC connectors
- ▶ Channel status report LED
- ▶ Coaxial cable recommended

General Purpose I/O Lines

- ▶ All I/O lines are TTL compatible with 4 input, 4 output, and 4 soft trigger lines.
- ▶ GPIO interface:
 - ▷ Two 10-pin header connectors on-board
 - ▷ The I/O lines are internally pulled up and have the following characteristics:

Voltage	MIN	MAX
Input high voltage (20 μ A)	2.0V	5.25V
Input low voltage (-0.2 μ A)	0.0V	0.80V
Output high voltage (-1.0mA)	5.0V	-
Output low voltage (100.0mA)	-	0.5V

Table 2-17: GPIO Characteristics

Channel Extension

- ▶ Expandable to up to 8 channels
- ▶ Channel extend interface
 - ▷ 10-pin ribbon cable to on-board 10-pin header connector for channel extension, each header adds 4 video inputs channels.

User EEPROM

- ▶ Includes 1kbit usable EEPROM

Form Factor

- ▶ 32/64bit, 33/66MHz, 6U Compact PCI board

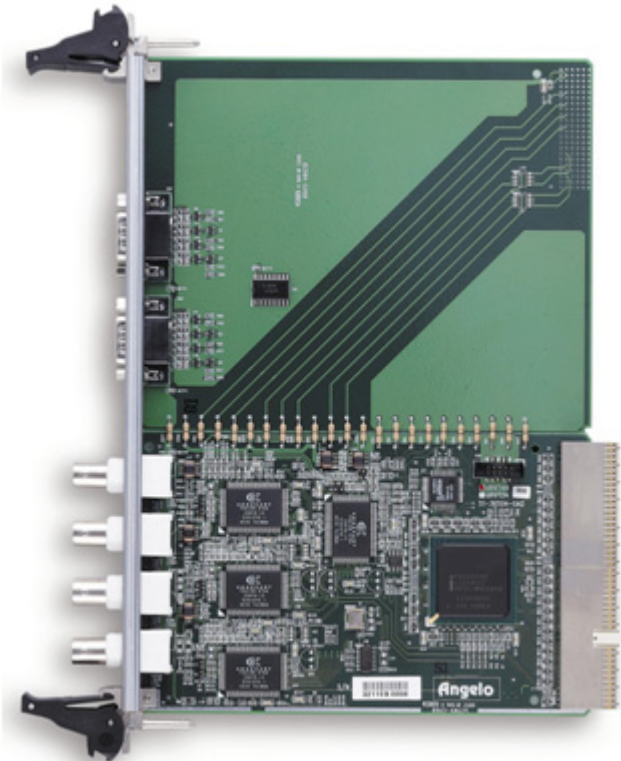

Figure 2-8: cRTV-44 Appearance

cRTV-44 Standard Accessories

- ▶ User Manual
- ▶ All in One CD





Connector	Definition
	CH0 (Channel 0 BNC)
	CH1 (Channel 1 BNC)
	CH2 (Channel 2 BNC)
	CH3 (Channel 3 BNC)

Table 2-18: cRTV Video Inputs



PIN	Function	PIN	Function
1	GND	2	CH4 video in
3	CH5 video in	4	GND
5	GND	6	CH6 video in
7	CH7 video in	8	GND
9	GND	10	GND

Table 2-19: Channel Extension Video Input (CN8)

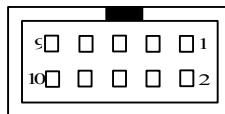
GPIO 0

- ▶ Pins IN0 and OUT0 are used by channel 0
- ▶ Pins IN1 and OUT1 are used by channel 1

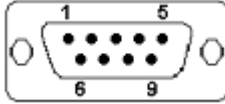

PIN	Function	PIN	Function
1	IN0 (External interrupt)	6	GND
2	OUT0	7	GND
3	IN1 (External interrupt)	8	GND
4	OUT1	9	+5V
5	GND		

Table 2-20: GPIO 0 Pinout

GPIO 1

- ▶ Pins IN2 and OUT2 are for channel 2
- ▶ Pins IN3 and OUT3 are for channel 3

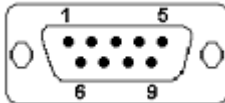

PIN	Function	PIN	Function
1	IN2 (External interrupt)	6	GND
2	OUT2	7	GND
3	IN3 (External interrupt)	8	GND
4	OUT3	9	+5V
5	GND		

Table 2-21: GPIO 1 Pinout

2.3 PMC-RTV series

PMC-RTV21 Specifications

Video Input

- ▶ Four composite video color digitizers
- ▶ Video input interface: DB-9 female connectors
- ▶ Coaxial cable recommended

General Purpose I/O Lines

- ▶ The I/O lines are TTL compatible with 1 input and 1 output
- ▶ GPIO interface:
 - ▷ One DB-9 male connector
 - ▷ The I/O lines are internally pulled up and have the following characteristics:

Voltage	MIN	MAX
Input high voltage (20 μ A)	2.0V	5.25V
Input low voltage (-0.2 μ A)	0.0V	0.80V
Output high voltage (-1.0mA)	5.0V	-
Output low voltage (100.0mA)	-	0.5V

Table 2-22: GPIO Characteristics

User EEPROM

- ▶ Includes 1kbit available EEPROM

Form Factor

- ▶ 32bit/33MHz PMC socket board



Figure 2-9: PMC-RTV21 Appearance

PMC-RTV21 Standard Accessories

- ▶ User Manual
- ▶ All in One CD

PMC-RTV21 Connectors & Pin Definition

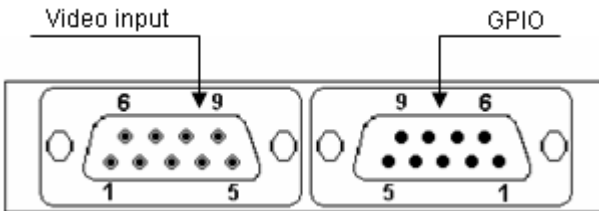
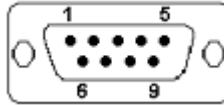
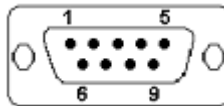

Figure 2-10: PMC-RTV21 Video Input & GPIO



PIN	Function	PIN	Function
1	GND	6	CH0 Video In
2	CH1 Video In	7	GND
3	GND	8	CH2 Video In
4	CH3 Video In	9	GND
5	--		

Table 2-23: Video Input



PIN	Function	PIN	Function
1	IN0 (External interrupt)	6	GND
2	OUT0	7	GND
3	--	8	GND
4	--	9	+5V
5	GND		

Table 2-24: GPIO Pinout

PMC-RTV21G Specifications

Video Input

- ▶ Four composite video color digitizers
- ▶ Video input interface: 10-pin header connectors
- ▶ Coaxial cable recommended

General Purpose I/O Lines

- ▶ The I/O lines are TTL compatible with 1 input and 1 output
- ▶ GPIO interface:
 - ▷ One 10-pin header connector
 - ▷ The I/O lines are internally pulled up and have the following characteristics:

Voltage	MIN	MAX
Input high voltage (20 μ A)	2.0V	5.25V
Input low voltage (-0.2mA)	0.0V	0.80V
Output high voltage (-1.0mA)	5.0V	-
Output low voltage (100.0mA)	-	0.5V

Table 2-25: GPIO Characteristics

User EEPROM

- ▶ Includes 1kbit available EEPROM

Form Factor

- ▶ 32bit/33MHz PMC socket board

PMC-RTV21G Connectors & Pin Definition

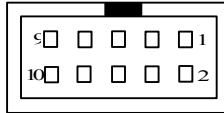

PIN	Function	PIN	Function
1	GND	2	CH0 Video In
3	CH1 Video In	4	GND
5	GND	6	CH2 Video In
7	CH3 Video In	8	GND
9	GND	10	GND

Table 2-26: Video Input

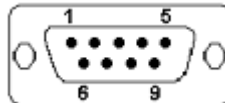

PIN	Function	PIN	Function
1	IN0 (External interrupt)	2	GND
3	OUT0	4	--
5	--	6	GND
7	--	8	+5V
9	GND	10	--

Table 2-27: GPIO Pinout

3 Installation Guide

3.1 Hardware Installation

RTV Series

Use the following steps to install the RTV series board on the PCI bus:

1. Remove the computer cover using the instructions from the computer manual.
2. Check that there is an empty PCI (32-bit) slot to accommodate the board. If there is not an empty slot, remove a PCI board from the computer to make room for the RTV-24 board and take note of the chosen slot number.
3. Remove the blank metal plate located at the back of the selected slot (if any). Keep the removed screw to fasten the RTV-24 board after installation.
4. Carefully position the RTV-24 in the selected PCI slot as illustrated below. If using a tower computer, orient the board to suit the board slots.

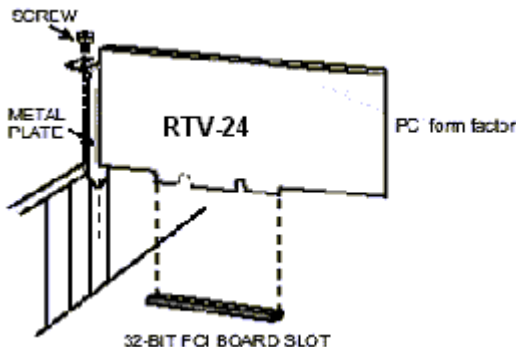

Figure 3-1: RTV-24 Installation

5. Once perfectly aligned with an empty slot, press the board firmly but carefully into the connector.

6. Anchor the board by replacing the screw.
7. Connect your video sources for image acquisition tests. For details, refer to the “ViewCreator Utility.”
8. Turn on the computer. In some cases, when the computer boots up, the “Plug and Play” feature of Windows will detect the new PCI card 8 times (4 videos and 4 audios) and you will require drivers. For details, see the “Installation Guide.”

cRTV Series

Use the following steps to install the cRTV series board onto the Compact PCI bus:

1. Remove the computer cover using the instructions from the computer manual.
2. Check that there is an empty cPCI (32-bit/64-bit) slot to accommodate the board. If is not an empty slot, remove a cPCI board to make room for the cRTV-24 (3U) / cRTV-44 (6U) board and take note of the chosen slot number.
3. Remove the blank metal plate located at the front of the selected slot (if present). Keep the removed screw to fasten the cRTV-24 (3U) / cRTV-44 (6U) board.
4. Carefully position the cRTV-24 or cRTV-44 in the selected cPCI slot as illustrated below.

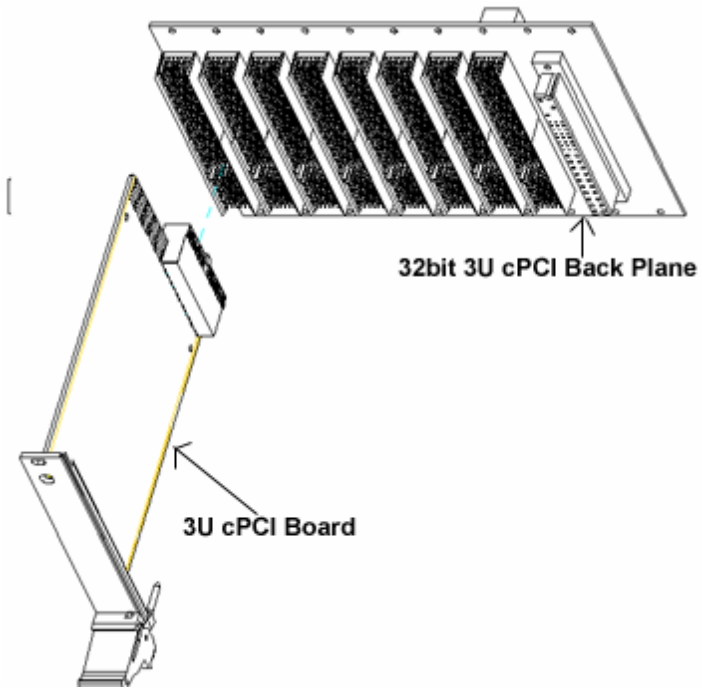

Figure 3-2: cRTV-24 (3U cPCI)

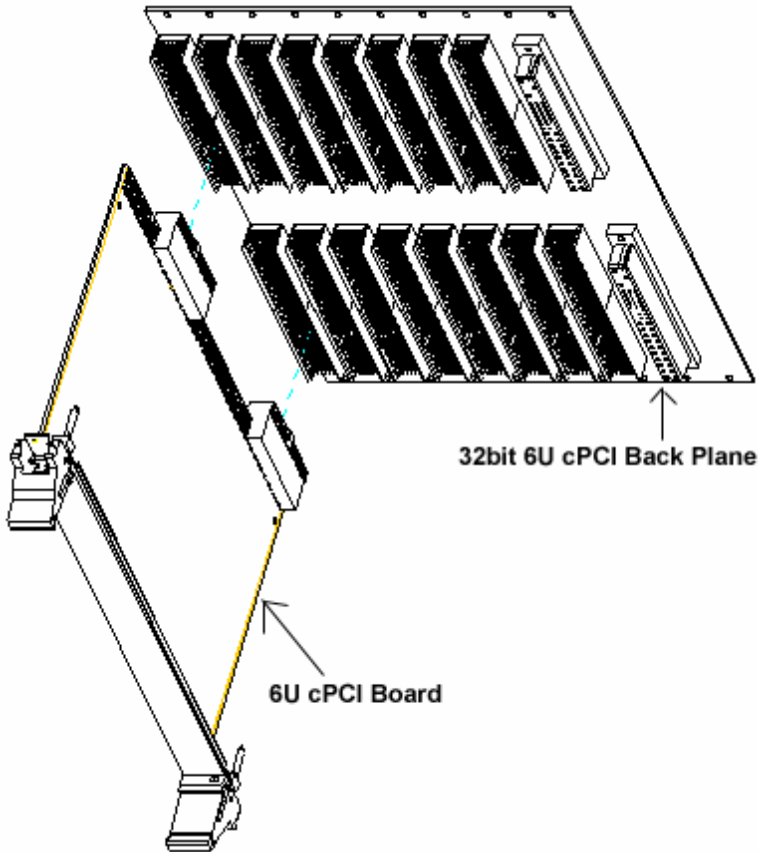

Figure 3-3: cRTV-44 (6U cPCI)

5. Carefully slide the cRTV-24 (3U)/cRTV-44 (6U) along the guide of the chosen slot to the backplane and push the board firmly but carefully into the connector, Lock the board in place by pushing the release lever outwards.
6. Anchor the board by replacing the screw.
7. Connect the video sources for image acquisition tests. For details, refer to the "ViewCreator Utility."

8. Turn on the computer. In some cases, when the computer boots up, the “Plug and Play” feature of Windows will detect the new PCI card 8 times (4 videos and 4 audios) and you will require drivers. For details, see the “Installation Guide.”

PMC-RTV Series

The PMC socket may be integrated with the cPCI CPU board or as a standalone system board for an embedded system. Use the following steps to install the PMC-RTV series board onto the PMC socket:

1. Remove the computer cover using the instructions from the computer manual.
2. Check that there is an empty PMC (32-bit) socket to accommodate the board. If there is not an empty slot, remove a PMC board from your computer to make room.
3. Carefully position PMC-RTV21 onto the PMC socket.
4. Once perfectly aligned with an empty PMC socket, press the board firmly but carefully into the connector.
5. Connect the video sources for image acquisition tests. For details, refer to the ‘ViewCreator Utility.’
6. Turn on the computer. In some cases, when the computer boots up, the “Plug and Play” feature of Windows will detect the new PCI card 8 times (1 video and 1 audio) and you will require drivers. For details, see the “Installation Guide.”

RTV-E4 Extension board (Optional)

1. For main board installation, please refer to ‘RTV series’.
2. Each RTV-E4 will attach one signal cable for connect with RTV-24 as below

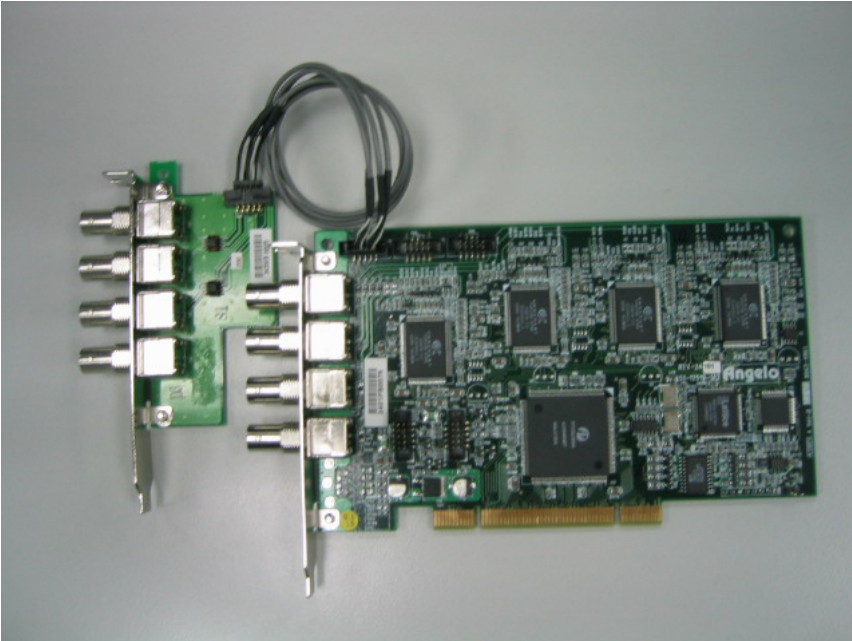

Figure 3-4: RTV-E4 Attachment

RTV-I4 Extension board (Optional)

1. For main board installation, please refer to 'RTV series'.
2. Each RTV-I4 will attach one signal cable for connect with RTV-24 as below

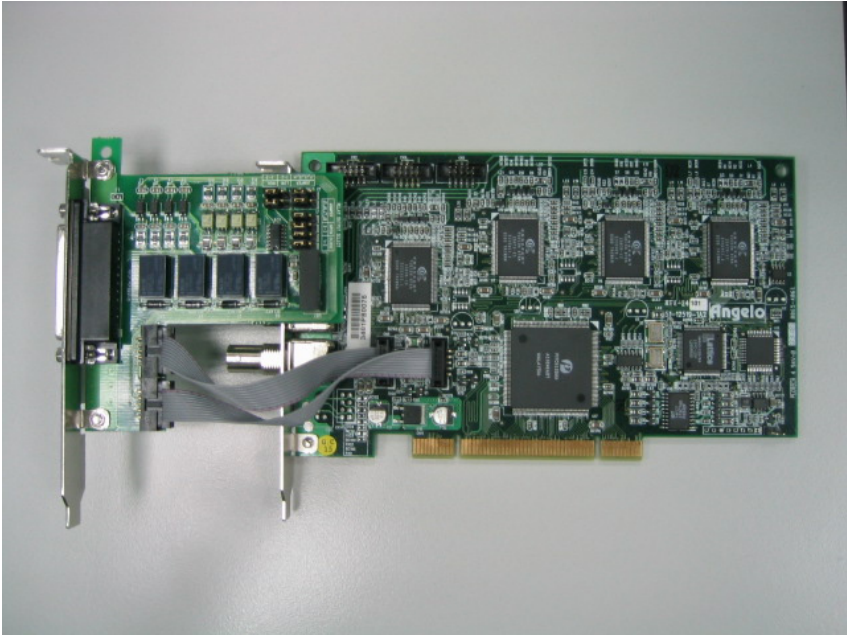

Figure 3-5: RTV-I4 Attachment

3.2 Driver Installation

WDM Driver Installation

Note: Do not plug in any Angelo series frame grabber before installing the software driver.

1. Insert the Automation All-in-one CD to CD-ROM drive and click Driver Installation

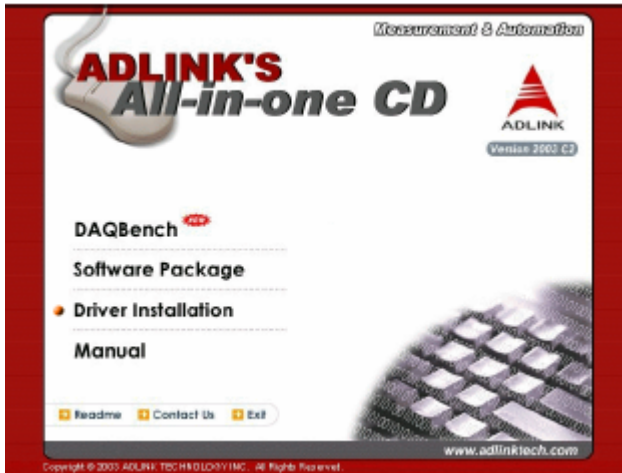

2. Select Vision



3. Click Angelo



4. Select Windows Driver for Windows 98/NT/2000/XP.



5. The driver will begin installing.

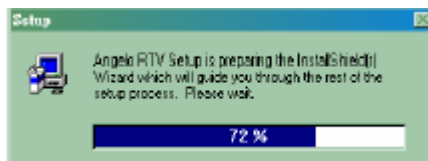

6. Click Next until driver install completely.



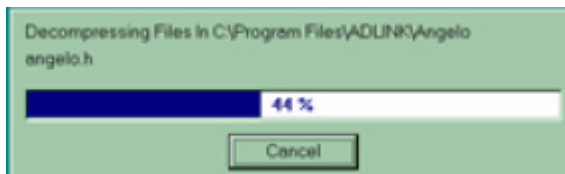
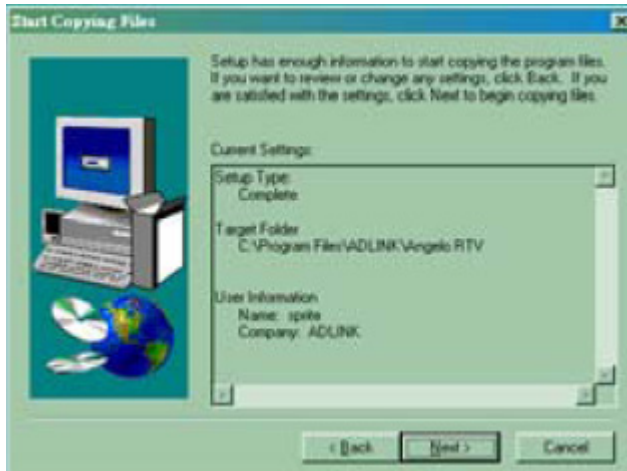

7. Click Finish and restart system.



8. The Found New Hardware Wizard window should appear after system restart. Click Next and follow the steps below to complete the new hardware wizard.





9. Click Next.

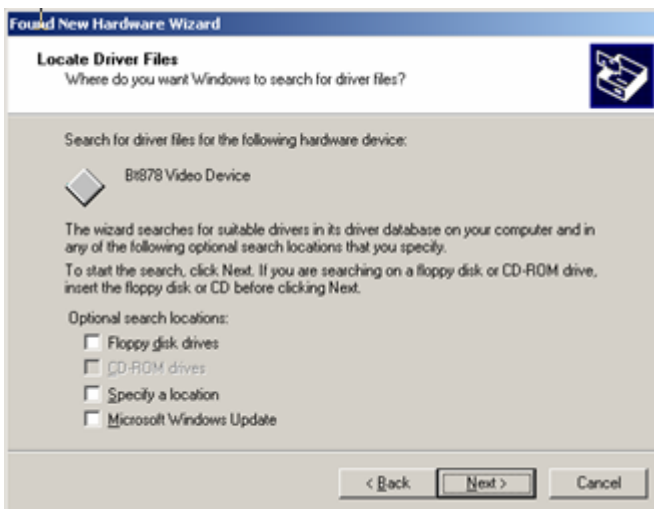

10. Click Next.

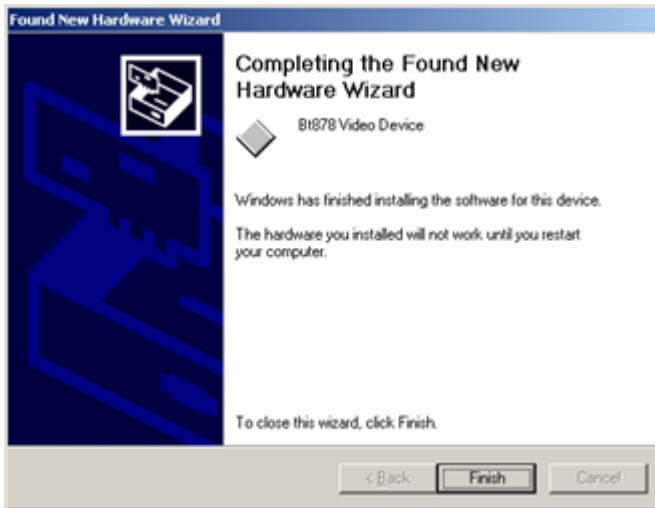

11. Click Finish.
12. Another Found New Hardware Wizard window will appear when the wizard completes. Repeat steps 8-11 until all wizards finish.
13. Go to system control panel and check multimedia devices. There should be four 'ADLINK Angelo Audio Device' and four 'ADLINK Angelo Video Device' as below.

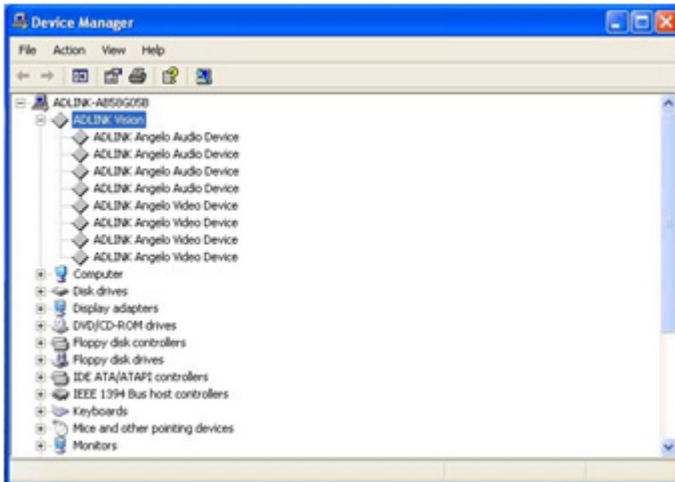

14.If you see a yellow question mark in front of the new driver name, you need to setup driver manually.

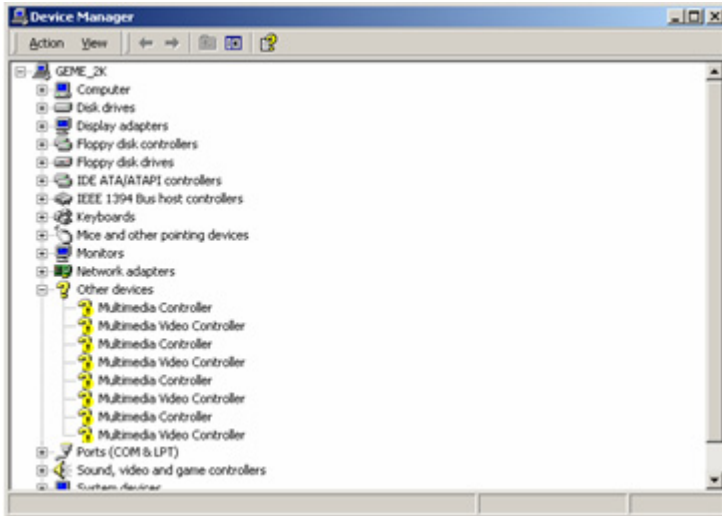

15. Right click on Multimedia Controller (which is a audio device), then select Properties from the popup menu. Follow the following steps to complete the driver re-installing.

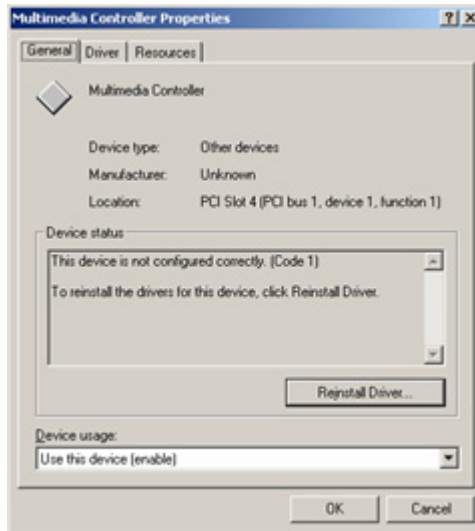

16. Click Reinstall Driver.



17. Click Next.



18. Click Next.

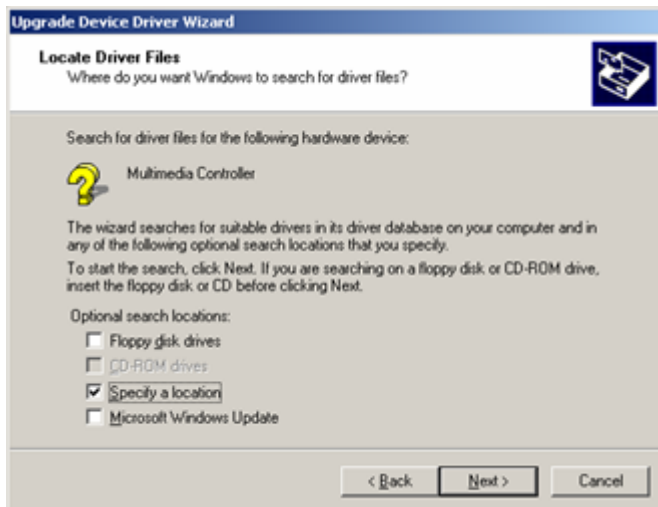

19. Check Specify a location and then click Next.



20. Input the location of driver installed in step 6, for example, 'C:\Program Files\ADLINK\Angelo.RTV\Drivers\Win2KXP'. Click OK.

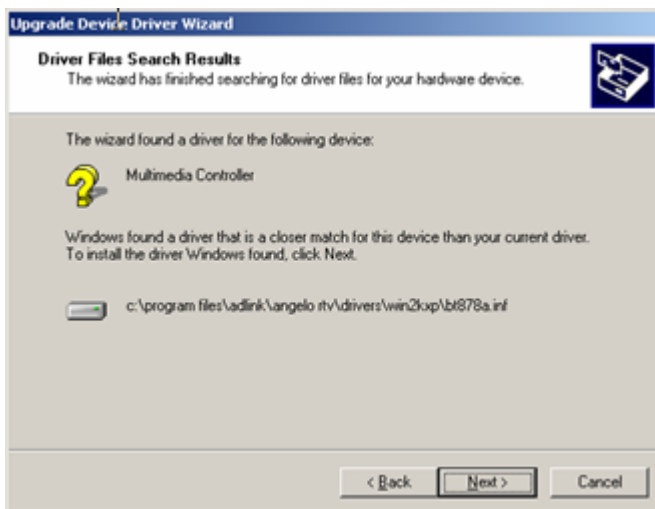

21. Click Next.



22. Click Finish to complete this wizard.

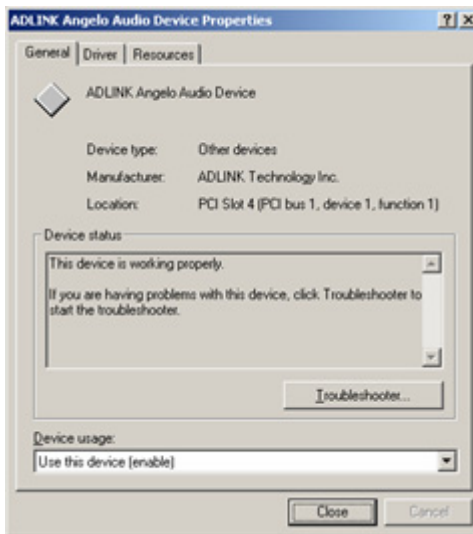

23. This device should be working properly.

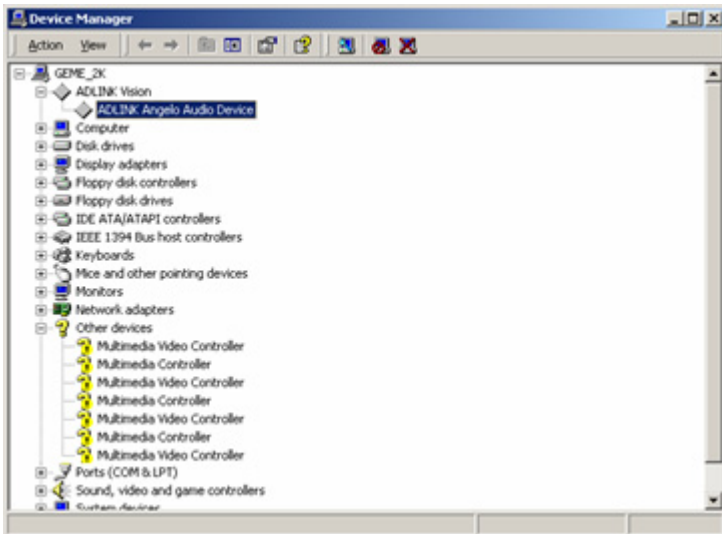

- 24. And the yellow question mark will disappear.
- 25. Repeat steps 15-24 for each of the devices to complete manual installation.

Note: If Windows prompts you to restart the computer, select No. Restart only after all devices have been installed.

- 26. For Angelo PMC-RTV21, please select GEME at the Driver Installation menu and follow the installation steps above.



Linux Driver Installation

The driver is compiled as a kernel module and works for kernel version 2.4.18 with Red Hat 7.3.

Reserve Memory

In order to reserve enough physical memory for the Angelo (Bt878) board, users need to run a command line argument and insert "mem" to boot loader configuration file to kernel (This example is for a system with 128MB RAM and wants to allocate 8MB memory for the Angelo(Bt878) board).

- ▶ If using the LILO boot loader, add `append=` to `/etc/lilo.conf` as below to reserve physical memory:

```
boot=/dev/hda
prompt
image=/boot/vmlinuz-2.4.18-3
label=linux
    initrd=/boot/initrd-2.4.18-3.img
    read-only
    root=/dev/hda9
    append="mem=120M"
```

Adding `append="mem=120M"` will configure the kernel to use 120MB physical memory, reserving the remaining 8MB for Angelo (Bt878).

Note: Be sure to manually execute `/sbin/lilo -v`

- ▶ If using the GRUB boot loader, add `mem=` to `/etc/grub.conf`.

```
default=0
timeout=10
splashimage=(hd0,1)/boot/grub/splash.xpm.gz
title Red Hat Linux (2.4.18-3)
root (hd0,1)
kernel /boot/vmlinuz-2.4.18-3 ro root=/dev/hda1
    mem=120M
```

Users can specify command line arguments to the interactive prompt at boot:

- ▶ LILO

```
LILO: linux mem=120M
```

► **GRUB**

▷ Press 'a' to modify kernel arguments.

```
root=/dev/hda1 mem=120M
```

Normally, each Angelo board video channel will require around 5MB physical memory space. If 4 channels will be used, then allocate 20MB. If 8 channels will be used, then allocate 40MB.

The GEME-V3000 and GEME-V2000 systems have one Bt878 chip on-board to provide one vision channel. The total physical memory space it needs is 5MB.

The PMC-RTV21/G board is a peripheral board for GEME systems which has one Bt878 chip, so it can provide one vision channel. The total physical memory space it needs is also 5MB.

Unpack

Decompress `angelo2.gz`:

```
tar xvzf angelo2.gz
```

This will extract the Angelo files with the following subdirectories:

```
driver/      device module and installation script
include/    header files for the library
lib/        shared library - libpci_878.so
examples/   example programs for Angelo for X-lib.
examples/example1  example program for one port
                  display with ImLib library
examples/example2  example program for one port
                  display with X-lib library
examples/example3  example program for four
                  port operations
examples/example4  example program for four
                  channel multiplexing
examples/example5  example program for image
                  geometric operations
examples/example6  example program for EEPROM
                  operations
examples/example7  example program for GPIO
                  operations
examples/example8  example program for save
                  image operations
```

```
examples/example9example program for software
trigger operations
examples/example10example program for Watch Dog
Timer operations
```

Install The Device

Before installing the Angelo (Bt878) driver module, please do the following:

1. Goto the driver sub-directory.
2. Run `Insmod -f mem_mgr.o` to insert the Angelo(Bt878) memory management module into kernel.

Because of the PCI-bus architecture, the Angelo (Bt878) board can be detected automatically. All users have to do is insert the Angelo driver modules and create nodes for the device. This can be done manually, or by running the following script:

```
<InstallDir>/angelo/driver/878.pl <no. of vision
channels>
```

- ▶ For three video channels on one card, run:
`./878.pl 3`
- ▶ For four video channels on one card, run:
`./878.pl 4`
- ▶ For eight video channels on two cards, run:
`./878.pl 8`
- ▶ To use the on-board vision channel of a GEME-V3000 or GEME-V2000 system:
`./878.pl 1`

Note: GEME-V3000 and GEME-V2000 systems have one vision channel on-board.

To use the on-board vision channel of a GEME-V3000 or GEME-V2000 system and one vision channel from the PMC-RTV21/G:

```
/878.pl 2
```

To define an installation directory (i.e. `/usr/local/angelo`), add the desired path to the end of the command:

```
./878.pl 2 /usr/local/angelo
```

Install The Library

To install the shared library, type the following command:

```
cp <InstallDir>/angelo/lib/libpci_878.so /usr/lib
```

The 878.pl script can also install the library.

Note: Automatic Driver Module Setup

To automatically setup the Angelo (Bt878) driver modules at boot, refer to the example below:

```
./878.pl 1  
cd /etc/rc3.d  
vi S99local
```

Append following two commands to the file:

```
insmod <InstallDir>/angelo/driver/mem_mgr.o  
insmod <InstallDir>/angelo/driver/p878.o
```

Now the two modules for the Angelo board(s) will be run automatically after reboot.

4 ViewCreator Utility

Once hardware installation is complete, ensure that they are configured correctly before running the ViewCreator utility. This chapter outlines how to establish a vision system and how to manually controlling Angelo series cards to verify correct operation. ViewCreator provides a simple yet powerful means to setup, configure, test, and debug the vision system.

Note: ViewCreator is only available for Windows 98/NT/2k/XP with a recommended screen resolution higher than 800x600.

4.1 Overview

- ▶ ViewCreator offers the following features:
- ▶ 32-bit operation under Windows 98/NT/2k/XP
- ▶ Angelo series cards access and configuration
- ▶ Video picture adjustments
- ▶ Image file saving (BMP or JPG)
- ▶ Direct access to general purpose I/Os
- ▶ FULL, CIF, or QCIF Image size, 2x2 or 4x4 display
- ▶ Software triggering

4.2 Component Description

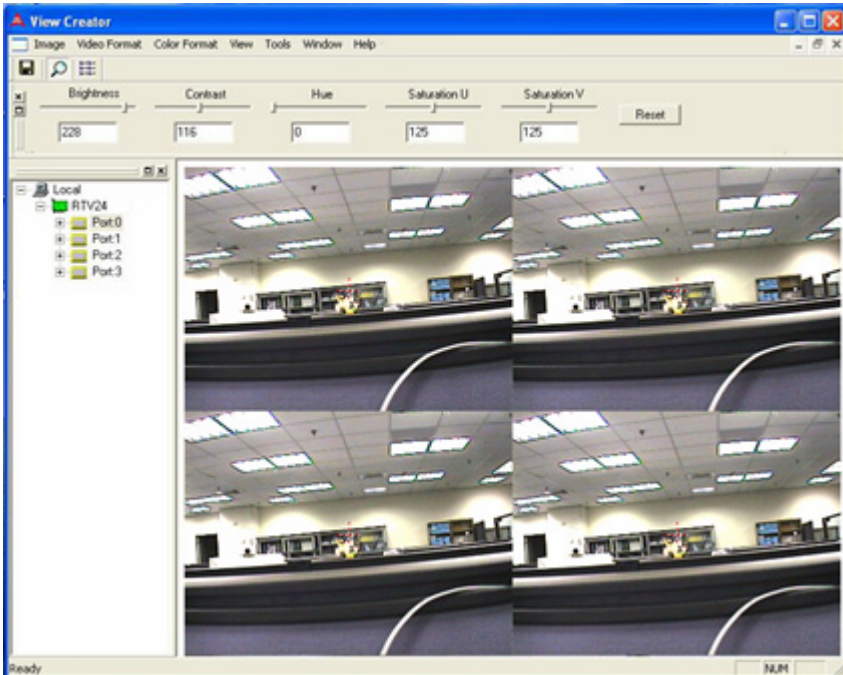

Figure 4-1: ViewCreator Main Screen

Tree Browser

The Tree Browser window lists the Angelo series cards and video ports available at the local computer.

Image View

The Image View window displays Full, CIF, and QCIF size images and image effect.

Control Panel

The control panel allows for making video adjustments including brightness, hue, contrast, etc.

4.3 Operation Theory

ViewCreator provides many functions for the RTV series card as described below.

Continuous Grab

Single Channel Display

Click a video Port icon in the Tree Browser window. A video frame will appear in the Image View window.

2x2 Channels

Click card icon in the Tree Browser window. All video ports in that card will appear in the Image View window.

All Channels

Click the Local icon in the Tree Browser window. All video ports in the system will appear in the Image View window.

Video Image Configuration

Video Format

Click Format in the menu bar to select the format of the video camera. The supported video formats are NTSC, EIA, PAL, and CCIR.

Color Format

The color format setting in ViewCreator is RGB24. The color format of the application can be changed.

Video Size

Click View in the menu bar and select the image size required. The supported video size listed below:

- ▶ FULL: 640x480 for NTSC, EIA and 768x576 for PAL, CCIR
- ▶ CIF: 320x240 for NTSC, EIA and 384x288 for PAL, CCIR
- ▶ QCF: 160x120 for NTSC, EIA and 192x144 for PAL, CCIR

Video Adjustments

Hue

Click and hold the left mouse button on the Hue slider of the Control Panel and drag the cursor to change its value. Values range from 0-255.

Contrast

Click and hold the left mouse button on the Contrast slider of the Control Panel and drag the cursor to change its value. Values range from 0-255

Brightness

Click and hold the left mouse button on the Brightness slider of the Control Panel and drag the cursor to change its value. Values range from 0-255

Save image file

This function can only be used in single channel display mode (select a video Port icon in the Tree Browser window).

JPG

Click Image in the menu bar and select Save As to bring up the Save As dialog box. Select the file location, JPG file format, enter the file name, and click the OK button.

BMP

Click Image in the menu bar and select Save As to bring up the Save As dialog box. Select the file location, BMP file format, enter the file name, and click the OK button.

Tools

GPIO & LED

Click Tool in the menu bar and select GPIO & LED item to bring up the GPIO dialog box. Select the port to access and select the digital output value. Click the write or read button to write/read to/from the digital I/O ports.

LED status is only supported with the cPCI Angelo series card.

EEPROM

Click Tool in the menu bar and select EEPROM to bring up the EEPROM dialog box. Select the card you wish to access, enter the offset and output values, and then click the Write button to write the value into the EEPROM. Enter the offset value and click the Read button to read the value from the EEPROM.

Valid offset values are between 0-127. Valid output values are 0-255. The value in the EEPROM will not be erased when the system is powered off.

Software Trigger

Click Tool in the menu bar and select Software Trigger to bring up the Trigger dialog box. Select the card to access and set the interval of the trigger pulse output. Check the ports you want to trigger simultaneously, and click the Trigger button.

The one shot pulse output voltage goes high (from 0V to 5V).

5 Function Library

This chapter describes the API for Angelo series cards. Users can use these functions to develop application programs under Visual C++, Visual Basic, C++ Builder, and Delphi.

5.1 List of Functions

Category	Section	Function
System	5.3	AngeloRTV_Initial(PortNo)
		AngeloRTV_Close(PortNo)
		AngeloRTV_Software_Reset(PortNo)
		AngeloRTV_Read_Serial(CardNo, HighByte, LowByte)
		AngeloRTV_Get_Version(DriverVersion, DLLVersion, Reserved)
Configuration	5.4	AngeloRTV_Set_Image_Config(PortNo, ConfigIndex, Value)
		AngeloRTV_Get_Image_Config(PortNo, ConfigIndex, Value)
		AngeloRTV_Set_Color_Format(PortNo, ColorFormat)
		AngeloRTV_Get_Color_Format(PortNo, ColorFormat)
		AngeloRTV_Set_Video_Format(PortNo, Value)
		AngeloRTV_Get_Video_Format(PortNo, Value)
		AngeloRTV_Set_Image_Geometric(PortNo, X_Offset, Y_Offset, X_Active, Y_Active, X_Scale, Y_Scale)
AngeloRTV_Detect_Video_Format(PortNo, FormatValue)		
Image Grabbing	5.5	AngeloRTV_Capture_Start(PortNo, CaptureNo)
		AngeloRTV_Select_Channel(PortNo, Multiplex)
		AngeloRTV_Capture_Stop (PortNo)
		AngeloRTV_Capture_Config(PortNo, Start_Field)
		AngeloRTV_Sync_Grab(PortNo, Start_Address, Width, Height, Size_Byte)
GPIO & EPROM	5.6	AngeloRTV_Set_GPIO_Sts(PortNo, Status)
		AngeloRTV_Get_GPIO_Sts(PortNo, Status)
		AngeloRTV_Set_GPIO_Int_Logic (PortNo, Logic)
		AngeloRTV_Write_EEPROM(PortNo, Offset, Value)
		AngeloRTV_Read_EEPROM(PortNo, Offset, Value)
		AngeloRTV_Set_LED_Sts (PortNo, LEDStatus)
Callback & Thread	5.7	AngeloRTV_Set_Int_Event(PortNo, hEvent)
		AngeloRTV_Set_Callback(PortNo, CallBackProc)
		AngeloRTV_Get_Int_Status(PortNo, IntStatus)
Software Trigger	5.8	AngeloRTV_Trigger_Config(PortNo, Interval)
		AngeloRTV_Trigger_Start(CardNo, Multiplex)
Frame Buffer	5.9	AngeloRTV_Get_frame(PortNo, Start_Address, Width, Height, Size_Byte)
		AngeloRTV_Save_File(PortNo, FileName, FileFormat, nQuality)
		AngeloRTV_Copy_frame(PortNo, Dest_Address, Size_Byte)

Table 5-1: List of Functions

5.2 C/C++ Programming Library

Function prototypes and common data types are defined in Angelo.h. The Angelo series library uses these data types. We suggest that these data types be used in your application programs. The following table shows the data types and their range:

Type Name	Description	Range
U8	8-bit ASCII character	0 to 255
I16	16-bit integer	-32768 to 32767
U16	16-bit unsigned integer	0 to 65535
I32	32-bit long integer	-2147483648 to 2147483647
U32	32-bit unsigned long integer	0 to 4294967295
F32	32-bit float	-3.402823E38 to 3.402823E38
F64	64-bit double float	-1.797683134862315E308 to 1.797683134862315E309
Boolean	Boolean logic	TRUE, FALSE

Table 5-2: C/C++ Data Types

5.3 System Functions

@ Name

AngeloRTV_Initial(PortNo)

Initialize the port in Angelo series card.

AngeloRTV_Close(PortNo)

Close the port in Angelo series card.

AngeloRTV_Software_Reset(PortNo)

Reset the port in Angelo series card.

AngeloRTV_Read_Serial(CardNo, HighByte, LowByte)

Read the unique 48-Bit Serial Number of Angelo Series Card (Only for RTV-24 Rev.B1 above, PCI-2100 Rev.A2 above)

AngeloRTV_Get_Version(DriverVersion, DLLVersion, Reserved)

Get the version of driver of AngeloRTV card and AngeloRTV.dll.

@ Description

AngeloRTV_Initial:

This function initializes the ports of the Angelo Series card. Each application program must call this function before any other functions can be used. If the initialization is executed successfully, it returns a value of 0.

Note: There are four ports on the RTV-24, cRTV-24, and cRTV-44 series cards, and one port on the PMC- RTV21.

AngeloRTV_Close:

Releases all resources from the ports.

AngeloRTV_Software_Reset:

Resets the port to its initial state.

AngeloRTV_Read_Serial:

This function can read a 48-bit unique ID and store in 2 Long interger.

AngeloRTV_Get_Version:

Used to get the current version of AngeloRTV card driver and AngeloRTV.dll file.

@ Syntax

C/C++ (Windows 98/NT/2000/XP/CE.NET)

```

I16 AngeloRTV_Initial(U16 PortNo)
I16 AngeloRTV_Close(U16 PortNo)
I16 AngeloRTV_Software_Reset(U16 PortNo)
U16 AngeloRTV_Read_Serial(U16 CardNo, U32* High-
    Byte, U32* LowByte);
I16 AngeloRTV_Get_Version(U32 *DriverVersion, U32
    *DLLVersion, U32 *Reserved)
  
```

Visual Basic (Windows 98/NT/2000/XP/CE.NET)

```

AngeloRTV_Initial (ByVal PortNo As Integer) As
    Integer
AngeloRTV_Close(ByVal PortNo As Integer) As Inte-
    ger
AngeloRTV_Software_Reset (ByVal PortNo As Inte-
    ger) As Integer
AngeloRTV_Read_Serial(Byval CardNo as Integer,
    ByRef HighByte As Long, ByRef LowByte As
    Long) As Integer
AngeloRTV_Get_Version (ByRef DriverVersion As
    Long, ByRef DLLVersion As Long, ByRef
    Reserved As Long) As Integer
  
```

Delphi (Windows 98/NT/2000/XP)

```

AngeloRTV_Initial(PortNo:Smallint):Smallint
AngeloRTV_Close (PortNo:Smallint):Smallint
AngeloRTV_Software_Reset (PortNo:Small-
    int):Smallint
AngeloRTV_Read_Serial(CardNo:Smallint; Var High-
    Byte: Longint; Var LowBytet:Longint):Small-
    int;
AngeloRTV_Get_Version (var DriverVersion:Longint;
    var DLLVersion:Longint; var Reserved:Long-
    int):Smallint
  
```

@ Arguments

PortNo:

Port number is the zero index of the Angelo series card. For example, if there are two RTV-24 Angelo cards (card 0, card 1) in the system, and each RTV-24 has four ports, the first port of card 0 is "0", and the first port of card 1 is "4."

HighByte:

HighByte stores the upper 16Bit of Serial No..

LowByte:

LowByte stores the lower 32Bit of Serial No.

DriverVersion:

Indicate the current version of AngeloRTV driver. This parameter is a pointer to an integer array with length 4.

DLLVersion:

Indicate the current version of AngeloRTV.dll file. This parameter is a pointer to an integer array with length 4.

@ Return Code

- ▶ 0: ERROR_NoError
- ▶ -2: ERROR_Card_Not_Exist – make sure the Angelo series card is plugged into the system, check the device manager to make sure the device is loaded, and the “PortNo” parameter is valid.
- ▶ -3: ERROR_Card_Not_Accessible – make sure the Angelo series card is plugged into the system, check the device manager to make sure the device is loaded, and the “PortNo” parameter is valid.
- ▶ -12: ERROR_CPLD_Check_Failed – Power off the computer and power on again.

@ Example

<VC/BCB >

AngeloRTV_Initial –

```
I16 Result;  
for(int PortNo= 0 ; PortNo <4;PortNo++)  
Result = AngeloRTV_Initial (PortNo);
```

AngeloRTV_Cose –

```
I16 Result;  
for(int PortNo= 0 ; PortNo <4;PortNo++)  
Result = AngeloRTV_Cose (PortNo);
```

AngeloRTV_Software_Reset–

```
I16 Result;  
for(int PortNo= 0 ; PortNo <4;PortNo++)  
Result = AngeloRTV_Software_Reset (PortNo);
```

AngeloRTV_Read_Serial–

```

int Result;
int CardNo = 0;
unsigned long HighByte = 0, LowByte = 0;
Result = AngeloRTV_Read_Serial(CardNo, &HighByte,
    &LowByte);

```

AngeloRTV_Get_Version –

```

I16 Result;
U32 DriverVersion[4] = {0}, DLLVersion[4] = {0},
    Reserved[4] = {0};
char strDriverVersion[20], strDLLVersion[20];
Result = AngeloRTV_Get_Version (DriverVersion,
    DLLVersion, Reserved);
sprintf(strDriverVersion, "%d.%d.%d.%d", Driver-
    Version[0], DriverVersion[1], DriverVer-
    sion[2], DriverVersion[3]);
sprintf(strDLLVersion, "%d.%d.%d.%d", DLLVer-
    sion[0], DLLVersion[1], DLLVersion[2],
    DLLVersion[3]);

```

< Visual Basic >

AngeloRTV_Initial –

```

Dim Result As Integer
Dim PortNo As Integer
For PortNo= 0 To 3
Result = AngeloRTV_Initial (ByVal PortNo)

```

AngeloRTV_Cose –

```

Dim Result As Integer
Dim PortNo As Integer
For PortNo= 0 To 3
Result = AngeloRTV_Close (ByVal PortNo)

```

AngeloRTV_Read_Serial–

```

Dim Result As Integer
Dim CardNo As Integer
Dim HighByte As Long, LowByte As Long
CardNo=0
HighByte=0
LowByte=0
Result = AngeloRTV_Read_Serial(CardNo, HighByte,
    LowByte)

```

AngeloRTV_Software_Reset–

```

Dim Result As Integer
Dim PortNo As Integer
For PortNo= 0 To 3
Result = AngeloRTV_Software_Reset (ByVal PortNo)

```

AngeloRTV_Get_Version –

```

Dim Result As Integer
Dim DriverVersion(3) As Long, DLLVersion(3) As
    Long, Reserved(3) As Long
Dim strDriverVersion, strDLLVersion As String
Result = AngeloRTV_Get_Version (DriverVersion(0),
    DLLVersion(0), Reserved(0))
strDriverVersion = CStr(DriverVersion(0)) + "." +
    CStr(DriverVersion(1)) + "." + CStr(Driver-
    Version(2)) + "." + CStr(DriverVersion(3))
strDLLVersion = CStr(DLLVersion(0)) + "." +
    CStr(DLLVersion(1)) + "." + CStr(DLLVer-
    sion(2)) + "." + CStr(DLLVersion(3))

```

<Delphi >

AngeloRTV_Initial –

```

var PortNo,Result:SmallInt;
for i:= 0 to 3 do
begin
Result := AngeloRTV_Initial (PortNo);
End;

```

AngeloRTV_Cose –

```

var PortNo,Result:SmallInt;
for i:= 0 to 3 do
begin
Result := AngeloRTV_Close (PortNo);
End;

```

AngeloRTV_Software_Reset–

```

var PortNo,Result:SmallInt;
for i:= 0 to 3 do
begin
Result := AngeloRTV_Software_Reset (PortNo);
End;

```

AngeloRTV_Read_Serial–

```

var
CardNo,Result:SmallInt;
HighByte, LowByte:SmallInt;
Result := AngeloRTV_Read_Serial(CardNo, HighByte,
LowByte)

```

AngeloRTV_Get_Version –

```

var
Result: Smallint;
DriverVersion: array[1..4] of Longint;
DLLVersion: array[1..4] of Longint;

```

```
Reserved: array[1..4] of Longint;  
strDriverVersion, strDLLVersion: String;  
Result := AngeloRTV_Get_Version (DriverVer-  
    sion[1], DLLVersion[1], Reserved[1]);  
strDriverVersion := IntToStr(DriverVersion[1]);  
strDriverVersion := strDriverVersion + '.' +  
    IntToStr(DriverVersion[2]);  
strDriverVersion := strDriverVersion + '.' +  
    IntToStr(DriverVersion[3]);  
strDriverVersion := strDriverVersion + '.' +  
    IntToStr(DriverVersion[4]);  
strDLLVersion := IntToStr(DLLVersion[1]);  
strDLLVersion := strDLLVersion + '.' +  
    IntToStr(DLLVersion[2]);  
strDLLVersion := strDLLVersion + '.' +  
    IntToStr(DLLVersion[3]);  
strDLLVersion := strDLLVersion + '.' +  
    IntToStr(DLLVersion[4]);
```

5.4 Configuration Functions

@ Name

AngeloRTV_Set_Image_Config(PortNo, ConfigIndex, Value)

Set the video adjustments.

AngeloRTV_Get_Image_Config(PortNo, ConfigIndex, Value)

Get the video adjustments.

AngeloRTV_Set_Color_Format(PortNo, ColorFormat)

Set the color format.

AngeloRTV_Get_Color_Format(PortNo, ColorFormat)

Get the color format.

AngeloRTV_Set_Video_Format(PortNo, Value)

Set the video format.

AngeloRTV_Get_Video_Format(PortNo, Value)

Set the video format.

AngeloRTV_Set_Image_Geometric(PortNo, X_Offset, Y_Offset, X_Active, Y_Active, X_Scale, Y_Scale)

Advanced image processing.

AngeloRTV_Detect_Video_Format(PortNo, FormatValue)

Detect the video format and if there is signal input.

@ Description

AngeloRTV_Set_Image_Config:

Adjusts the hue, contrast, Saturation and brightness of the port for the Angelo series card.

AngeloRTV_Get_Image_Config:

Retrieves the current hue, contrast, Saturation and brightness setting of the port for the Angelo series card.

AngeloRTV_Set_Color_Format:

Sets the color format of the port for the Angelo series card. Valid color formats are: gray scale, RGB.

AngeloRTV_Get_Color_Format:

Retrieves the color format of the port for the Angelo series card.

AngeloRTV_Set_Video_Format:

Sets the Video format of the port for the Angelo series card. Valid color formats are: NTSC, EIA, PAL, CCIR.

AngeloRTV_Get_Video_Format:

Retrieves the video format of the port for the Angelo series card.

AngeloRTV_Set_Image_Geometric:

This function is used for image cropping and scaling.

AngeloRTV_Detect_Video_Format:

Use the function to retrieve the video format. And if the return value of the 2nd parameter is 0 that means there is no signal input.

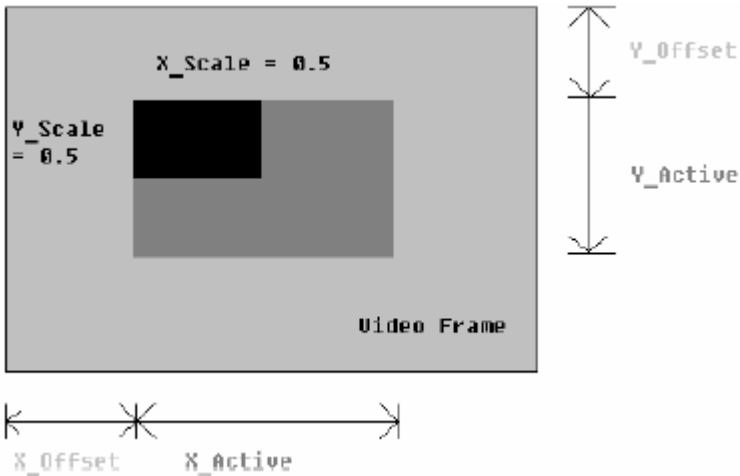

Figure 5-1: Video Frame

@ Syntax

C/C++ (Windows 98/NT/2000/XP/CE.NET)

```
I16 AngeloRTV_Set_Image_Config(U16 PortNo,U8 Con-
    figIndex , U8 Value);
```

```
I16 AngeloRTV_Get_Image_Config(U16 PortNo,U8 Con-
    figIndex , U8* Value);
```



```

I16 AngeloRTV_Set_Color_Format (U16 PortNo, U8
    ColorFormat);
I16 AngeloRTV_Get_Color_Format (U16 PortNo, U8*
    ColorFormat);
I16 AngeloRTV_Set_Video_Format (U16 PortNo, U8
    VideoFormat);
I16 AngeloRTV_Set_Video_Format (U16 PortNo, U8*
    VideoFormat);
I16 AngeloRTV_Set_Image_Geometric(U16 PortNo, U32
    X_Offset, U32 Y_Offset, U32 X_Active, U32
    Y_Active, double X_Scale, double Y_Scale);
I16 AngeloRTV_Detect_Video_Format (U16 PortNo, U8
    *FormatValue);

```

Visual Basic (Windows 98/NT/2000/XP/CE.NET)

```

AngeloRTV_Set_Image_Config(ByVal PortNo As Integer,
    ByVal ConfigIndex As Byte, ByVal Value
    As Byte) As Integer
AngeloRTV_Get_Image_Config(ByVal PortNo As Integer,
    ByVal ConfigIndex As Byte, ByRef Value
    As Byte) As Integer
AngeloRTV_Set_Color_Format (ByVal PortNo As
    Integer, ByVal ColorFormat As Byte) As Integer
AngeloRTV_Get_Color_Format (ByVal PortNo As
    Integer, ByRef ColorFormat As Byte) As Integer
AngeloRTV_Set_Video_Format (ByVal PortNo As
    Integer, ByVal VideoFormat As Byte) As Integer
AngeloRTV_Set_Video_Format (ByVal PortNo As
    Integer, ByRef VideoFormat As Byte) As Integer
AngeloRTV_Set_Image_Geometric(ByVal PortNo As
    Integer, ByVal X_Offset As Long, ByVal
    Y_Offset As Long, ByVal X_Active As Long,
    ByVal Y_Active As Long, ByVal X_Scale As
    Double, ByVal Y_Scale As Double) As Integer
AngeloRTV_Detect_Video_Format (ByVal PortNo,
    ByRef FormatValue As Byte) As Integer

```

Delphi (Windows 98/NT/2000/XP)

```

AngeloRTV_Set_Image_Config(PortNo:Smallint;Con-
    figIndex:Byte;Value:Byte): Smallint;
AngeloRTV_Get_Image_Config(PortNo:Small-

```

```
int; ConfigIndex: Byte; var Value: Byte): Smallint;  
AngeloRTV_Set_Color_Format (PortNo: Smallint; ColorFormat: Byte): Smallint;  
AngeloRTV_Get_Color_Format (PortNo: Smallint; var ColorFormat: Byte): Smallint;  
AngeloRTV_Set_Video_Format (PortNo: Smallint; VideoFormat: Byte): Smallint;  
AngeloRTV_Get_Video_Format (PortNo: Smallint; var VideoFormat: Byte): Smallint;  
AngeloRTV_Set_Image_Geometric (PortNo: Smallint; X_Offset: LongInt; Y_Offset: LongInt; X_Active: LongInt; Y_Active: LongInt; X_Scale: Double; Y_Scale: Double): Smallint;  
AngeloRTV_Detect_Video_Format (PortNo: Smallint; var FormatValue: Byte): Smallint;
```

@ Arguments

PortNo:

Port number is the zero index of the Angelo series card. For example, if there are two PCI-RTV-24 Angelo cards (card 0, card 1) in the system, and each PCI-RTV-24 has four ports, the first port of card 0 is "0", and the first port of card 1 is "4."

ConfigIndex:

- ▶ 0 for BRIGHTNESS
- ▶ 1 for HUE
- ▶ 2 for SATURATION (U)
- ▶ 3 for SATURATION (V)
- ▶ 4 for CONTRAST (LUMA)
- ▶ 5 for luma notch filter (for monochrome video, the notch filter should not be used)

Value: (0-255)

- ▶ Range Default value
- ▶ BRIGHTNESS 0 ---- 255 128
- ▶ HUE 0 ---- 255 0
- ▶ CHROMA (U) 0 ---- 255 127
- ▶ CHROMA (V) 0 ---- 255 127
- ▶ LUMA 0 ---- 255 108
- ▶ LUMA notch filter 0(Enable) or 1(Disable)

Color Format:

- ▶ RGB16 = 0,
- ▶ GRAY = 1,
- ▶ RGB15 = 2,
- ▶ RGB24 = 3,
- ▶ RGB32 = 4,
- ▶ RGB8 = 5,
- ▶ RAW8X = 6,
- ▶ YUY24:2:2= 7,

Video Format:

- ▶ Full NTSC (640*480) = 0,
- ▶ Full PAL (768*576) = 1,
- ▶ CIF NTSC (320*240) = 2,
- ▶ CIF PAL (384*288) = 3,
- ▶ QCIF NTSC (160*120) = 4,
- ▶ QCIF PAL (192*144) = 5,

Note: Please do not use Full NTSC and Full PAL format to acquire dynamic object image, because the interlaced scanning may not be able to present clear image for it.

X_Scale:

This parameter is the scaling factor applied to the Angelo sampled line to obtain pixels according to the resolution.

X_Active

This parameter value is the length of the active video line

X_Offset

This parameter value is the number of scaled pixels to skip before the start of the active video line.

Y_Scale:

This parameter is the scaling factor applied to the Angelo sampled data lines in the vertical direction. It must be the following values:

- ▶ *Y_Scale* = 1.0
- ▶ *Y_Scale* = 0.5
- ▶ *Y_Scale* = 0.25

Y_Active

This parameter value is the height (in lines) of the active video image.

Y_Offset

This parameter value is the number of lines to skip before the first line of the active video image.

FormatValue:

If the return value of this parameter is 0 that means there is no video signal input. And if the value is 1 or 2, the video format of the port is NTSC. Otherwise, if the value is 3, 4 or 5, the video format of the port is PAL.

@ Example

<VC/BCB >

AngeloRTV_Set_Image_Config –

AngeloRTV_Get_Image_Config –

```
I16 Result;
```

```
I16 PortNo = 0;
```

```
U8 ConfigIndex = 0;
```

```
U8 Value = 128;
```

```
Result = AngeloRTV_Set_Image_Config (PortNo,  
ConfigIndex, Value);
```

```
Result = AngeloRTV_Get_Image_Config (PortNo,  
ConfigIndex, &Value);
```

AngeloRTV_Set_Color_Format –

AngeloRTV_Get_Color_Format –

AngeloRTV_Set_Video_Format –

AngeloRTV_Get_Video_Format –

```
I16 Result;
```

```

I16 PortNo = 0;
U8 VideoFormat = 0;
U8 ColorFormat = 3;
Result = AngeloRTV_Set_Color_Format(PortNo, ColorFormat);
Result = AngeloRTV_Get_Color_Format(PortNo, &ColorFormat);
Result = AngeloRTV_Set_Video_Format(PortNo, VideoFormat);
Result = AngeloRTV_Get_Video_Format(PortNo, &VideoFormat);

```

AngeloRTV_Set_Image_Geometric –

```

I16 Result;
I16 PortNo = 0;
U32 X_Active = 600;
U32 Y_Active = 400;
U32 X_Offset = 40;
U32 Y_Offset = 80;
Double X_Scale = 1.0;
Double Y_Scale = 1.0;
Result = AngeloRTV_Set_Image_Geometric (PortNo, X_Offset, Y_Offset, X_Active, Y_Active, X_Scale, Y_Scale);

```

AngeloRTV_Detect_Video_Format –

```

I16 Result;
U16 PortNo;
U8 FormatValue;
PortNo = 0;
Result = AngeloRTV_Detect_Video_Format (PortNo, &FormatValue);

```

< Visual Basic >

AngeloRTV_Set_Image_Config –

AngeloRTV_Get_Image_Config –

```

Dim Result As Integer
Dim PortNo As Integer
Dim ConfigIndex As Byte
Dim Value As Byte
PortNo = 0
ConfigIndex = 0
Value = 128
Result = AngeloRTV_Set_Image_Config (ByVal PortNo, ByVal ConfigIndex, ByVal Value)

```

```
Result = AngeloRTV_Get_Image_Config (ByVal
    PortNo, ByVal ConfigIndex, ByRef Value)
AngeloRTV_Set_Color_Format -
AngeloRTV_Get_Color_Format -
AngeloRTV_Set_Video_Format -
AngeloRTV_Get_Video_Format -
Dim Result As Integer
Dim PortNo As Integer
Dim ColorFormat As Byte
Dim VideoFormat As Byte
PortNo = 0
ColorFormat = 3
VideoFormat = 0
Result = AngeloRTV_Set_Color_Format (ByVal PortNo,
    ByVal ColorFormat)
Result = AngeloRTV_Get_Color_Format (ByVal PortNo,
    ByRef ColorFormat)
Result = AngeloRTV_Set_Video_Format (ByVal PortNo,
    ByVal VideoFormat)
Result = AngeloRTV_Get_Video_Format (ByVal PortNo,
    ByRef VideoFormat)
AngeloRTV_Set_Image_Geometric -
Dim Result As Integer
Dim PortNo As Integer
Dim X_Active As Long
Dim Y_Active As Long
Dim X_Offset As Long
Dim Y_Offset As Long
Dim X_Scale As Double
Dim Y_Scale As Double
PortNo = 0
X_Active = 600
Y_Active = 400
X_Offset = 40
Y_Offset = 80
X_Scale = 1.0
Y_Scale = 1.0
Result = AngeloRTV_Set_Image_Geometric (PortNo,
    X_Offset, Y_Offset, X_Active, Y_Active,
    X_Scale, Y_Scale)
AngeloRTV_Detect_Video_Format -
Dim Result As Integer
Dim PortNo As Integer
```

```

Dim FormatValue As Byte
PortNo = 0
Result = AngeloRTV_Detect_Video_Format (ByVal
    PortNo, ByRef FormatValue)

```

<Delphi >

AngeloRTV_Set_Image_Config –

AngeloRTV_Get_Image_Config –

```

Var
Result : SmallInt;
PortNo : SmallInt;
ConfigIndex: Byte;
Value: Byte;
PortNo:=0;
ConfigIndex:=0;
Value:=0;
Result := AngeloRTV_Set_Image_Config (PortNo,Con-
    figIndex, Value);
Result := AngeloRTV_Get_Image_Config (PortNo,
    ConfigIndex, Value);

```

AngeloRTV_Set_Color_Format –

AngeloRTV_Get_Color_Format –

AngeloRTV_Set_Video_Format –

AngeloRTV_Get_Video_Format –

```

Var
Result : SmallInt;
PortNo : SmallInt;
VideoFormat: Byte;
ColorFormat: Byte;
PortNo:=0;
VideoFormat:=0;
ColorFormat:=3;
Result := AngeloRTV_Set_Color_Format(PortNo,Col-
    orFormat);
Result := AngeloRTV_Get_Color_Format(PortNo,Col-
    orFormat);
Result := AngeloRTV_Set_Video_Format(PortNo,VideoFor-
    mat);
Result := AngeloRTV_Get_Video_Format(PortNo,
    VideoFormat);

```

AngeloRTV_Set_Image_Geometric –

```

Var
Result : SmallInt;

```

```
PortNo : SmallInt;  
X_Active : LongInt;  
Y_Active : LongInt;  
X_Offset : LongInt;  
Y_Offset : LongInt;  
X_Scale : Double;  
Y_Scale : Double;  
PortNo := 0;  
X_Active := 600;  
Y_Active := 400;  
X_Offset := 40;  
Y_Offset := 80;  
X_Scale := 1.0;  
Y_Scale := 1.0;  
Result := AngeloRTV_Set_Image_Geometric(PortNo,  
    X_Offset, Y_Offset, X_Active, Y_Active,  
    X_Scale, Y_Scale);
```

AngeloRTV_Detect_Video_Format –

```
var  
Result : SmallInt;  
PortNo : SmallInt;  
FormatValue : Byte;  
PortNo := 0;  
Result := AngeloRTV_Detect_Video_Format (PortNo,  
    FormatValue);
```

5.5 Image Grabbing

@ Name

AngeloRTV_Capture_Start(PortNo, CaptureNo)

Start to grab the video image

AngeloRTV_Select_Channel(PortNo, Multiplex)

Channel extension of video signal, for advanced only

AngeloRTV_Capture_Stop(PortNo)

Stop to grab the video image

AngeloRTV_Capture_Config(PortNo, Start_Field)

Set the starting field of image

AngeloRTV_Sync_Grab(PortNo, Start_Address, Width, Height, Size_Byte)

Get an image frame with start address of memory

@ Description

AngeloRTV_Capture_Start:

Continuously captures video frames and stops when the total frame number equals the “CaptureNo” parameter. The frame update rate is 30 frames/sec. If the “CaptureNo” is 0xFFFFFFFF, the frame grabbing will not stop until the “AngeloRTV_Capture_Stop” function is called.

AngeloRTV_Capture_Stop:

Stop grabbing video frames.

AngeloRTV_Select_Channel:

Angelo series cards are capable of channel extension. This function is used to multiplex video signals for the ports. In most cases using this function should not be required because the default setting is one port is dedicated to one channel.

Note: Do not call this function if there is no channel extension board in the system.

AngeloRTV_Capture_Config:

Chooses the starting field of image.

AngeloRTV_Sync_Grab:

This is a synchronous image grabbing function to get an image frame. Retrieve the memory start address from the frame data, width, height, and size in bytes of the image.

@ Syntax

C/C++ (Windows 98/NT/2000/XP/CE.NET)

```
I16 AngeloRTV_Capture_Start (U16 PortNo, U32 CaptureNo)
I16 AngeloRTV_Select_Channel (U16 PortNo, U16 Multiplex)
I16 AngeloRTV_Capture_Stop (U16 PortNo)
I16 AngeloRTV_Capture_Config (U16 PortNo, U32 Start_Field)
I16 AngeloRTV_Sync_Grab(U16 PortNo, U32* Start_Address, U32* Width, U32* Height, U32* Size_Byte)
```

Visual Basic (Windows 98/NT/2000/XP/CE.NET)

```
AngeloRTV_Capture_Start (ByVal PortNo As Integer,
    ByVal CaptureNo As Long) As Integer
AngeloRTV_Select_Channel (ByVal PortNo As Integer,
    ByVal Multiplex As Integer) As Integer
AngeloRTV_Capture_Stop (ByVal PortNo As Integer)
    As Integer
AngeloRTV_Capture_Config (ByVal PortNo As Integer,
    ByVal Start_Field As Long) As Integer
AngeloRTV_Sync_Grab(ByVal PortNo As Integer,
    ByRef Start_Address As Long, ByRef Width as
    Long, ByRef Height As Long, ByRef Size_byte
    As Long) As Integer
```

Delphi (Windows 98/NT/2000/XP)

```
AngeloRTV_Capture_Start (PortNo:Smallint; CaptureNo:Longint):Smallint
AngeloRTV_Select_Channel (PortNo:Smallint; Multiplex:Smallint):Smallint
AngeloRTV_Capture_Stop (PortNo:Smallint):Smallint
AngeloRTV_Capture_Config (PortNo:Smallint; Start_Field:Longint):Smallint
AngeloRTV_Sync_Grab(PortNo:Smallint; var Start_Address:Pointer; var Width:Longint;
    var Height:Longint; var Size_byte:Longint):Smallint
```

@ Argument

PortNo:

Port number is the zero index of the Angelo series card. For example, if there are two PCI-RTV-24 Angelo cards (card 0, card 1) in the system, and each PCI-RTV-24 has four ports, the first port of card 0 is "0", and the first port of card 1 is "4."

CaptureNo:

Total number of frames to capture. If the "CaptureNo" is 0xFFFFFFFF, the frame grabbing will not stop until the "AngeloRTV_Capture_Stop" function is called.

Multiplex:

Indicates the multiplex channels.

- ▶ Bit 0 : Channel 0, 0 for disable ; 1 for enable.
- ▶ Bit 1 : Channel 1, 0 for disable ; 1 for enable.
- ▶ Bit 2 : Channel 2, 0 for disable ; 1 for enable.
- ▶ Bit 3 : Channel 3, 0 for disable ; 1 for enable.

For example:

- ▶ Multiplex = 1, only channel 0 is enable
- ▶ Multiplex = 2, only channel 1 is enable
- ▶ Multiplex = 15, four channels are enable

Start_Filed:

Indicates the first field of image.

- ▶ 0: first field is Odd, so the image will be Odd field + Even field.
- ▶ 1: first field is Even, so the image will be Even field + Odd field.
- ▶ 2: first field depends on the current field, so the image will be Even field + Odd field, or Odd field + Even field.

Start_Address:

Memory start address of the video frame.

Width:

Image width.

Height:

Image height.

Size_Byte:

Memory size in bytes.

@ Return Code

- ▶ 0: ERROR_NoError
- ▶ -7: ERROR_Not_Initialized – Make sure the port has been initialized by “AngeloRTV_Initial”.
- ▶ -9: ERROR_Invalid_PortNo – Please input the correct “PortNo” parameter.

@ Example

<VC/BCB >

AngeloRTV_Capture_Config –

AngeloRTV_Capture_Start –

AngeloRTV_Sync_Grab –

AngeloRTV_Capture_Stop –

```
I16 Result;  
U16 PortNo = 0;  
U32 CaptureNo = 0xFFFFFFFF;  
U32 Start_Field = 0;  
U32 StrAddr;  
U32 Width, Height, Size_Byte;  
Result = AngeloRTV_Capture_Config (PortNo,  
    Start_Field);  
Result = AngeloRTV_Capture_Start (PortNo, Cap-  
    tureNo);  
Result = AngeloRTV_Sync_Grab (PortNo, &StrAddr,  
    &Width, &Height, &Size_Byte);  
Result = AngeloRTV_Capture_Stop (PortNo);
```

< Visual Basic >

AngeloRTV_Capture_Config –

AngeloRTV_Capture_Start –

AngeloRTV_Sync_Grab –

```
AngeloRTV_Capture_Stop -  
Dim Result As Integer  
Dim PortNo As Integer  
Dim CaptureNo As Long  
Dim Start_Field As Long
```

```

Dim StrAddr As Long
Dim Width as Long, Height As Long, Size_Byte As
    Long
PortNo = 0
CaptureNo = &HFFFFFFF
Start_Field = 0
Result = AngeloRTV_Capture_Config (ByVal PortNo,
    ByVal Start_Field)
Result = AngeloRTV_Capture_Start (ByVal PortNo,
    ByVal CaptureNo)
Result = AngeloRTV_Sync_Grab (ByVal PortNo,
    StrAddr, Width, Height, Size_Byte)
Result = AngeloRTV_Capture_Stop (ByVal PortNo)

```

<Delphi >

AngeloRTV_Capture_Config –

AngeloRTV_Capture_Start –

AngeloRTV_Sync_Grab –

AngeloRTV_Capture_Stop –

```

Var
Result : SmallInt;
PortNo: SmallInt;
CaptureNo: LongInt;
Start_Field: LongInt;
StrAddr: Pointer;
Width, Height, Size_Byte: LongInt;
begin
PortNo:=0;
Start_Field :=0;
CaptureNo:= INFINITE;
Result := AngeloRTV_Capture_Config (PortNo,
    Start_Field);
Result := AngeloRTV_Capture_Start (PortNo, Cap-
    tureNo);
Result := AngeloRTV_Sync_Grab (PortNo, StrAddr,
    Width, Height, Size_Byte);
Result: = AngeloRTV_Capture_Stop (PortNo);
end;

```

5.6 GPIO & EEPROM Functions

@ Name

AngeloRTV_Set_GPIO_Sts (PortNo, Status)

Set Digital Output status.

AngeloRTV_Get_GPIO_Sts (PortNo, Status)

Get Digital Input status.

AngeloRTV_Set_GPIO_Int_Logic (PortNo, Logic)

Configure the Digital Input Interrupt condition

AngeloRTV_Write_EEPROM (PortNo, Offset, Value)

Write data into EEPROM

AngeloRTV_Read_EEPROM (PortNo, Offset, Value)

Read data from EEPROM

AngeloRTV_Set_LED_Sts (PortNo, LEDStatus)

Set LED status for cPCI RTV24 card.

@ Description

AngeloRTV_Set_GPIO_Sts:

There is one digital output channel in each port of the Angelo series card, use this function to set the digital output status.

AngeloRTV_Get_GPIO_Sts:

There is one digital input channel in each port of Angelo series card, use this function to get the digital input status.

AngeloRTV_Set_GPIO_Int_Logic:

This function used to configure the Digital Input Interrupt condition.

AngeloRTV_Write_EEPROM:

Writes data into the EEPROM. Data in EEPROM will not be lost even when powered off.

AngeloRTV_Read_EEPROM:

Reads data from the EEPROM. Data in EEPROM will not be lost even when powered off.

AngeloRTV_Set_LED_Sts:

Use the function to set LED status. The function is for cPCI RTV24 card only.

@ Syntax

C/C++ (Windows 98/NT/2000/XP/CE.NET)

```
I16 AngeloRTV_Set_GPIO_Sts(U16 PortNo,U8 Status);
I16 AngeloRTV_Get_GPIO_Sts(U16 PortNo,U8* Status);
I16 AngeloRTV_Set_GPIO_Int_Logic(U16 PortNo, U16 Logic);
I16 AngeloRTV_Write_EEPROM(U16 CardNo, U8 Offset, U8 Value);
I16 AngeloRTV_Read_EEPROM(U16 CardNo, U8 Offset, U8* Value);
I16 AngeloRTV_Set_LED_Sts (U16 PortNo, U8 LEDStatus);
```

Visual Basic (Windows 98/NT/2000/XP/CE.NET)

```
AngeloRTV_Set_GPIO_Sts (ByVal PortNo As Integer,
    ByVal Status As Byte) As Integer
AngeloRTV_Get_GPIO_Sts (ByVal PortNo As Integer,
    ByRef Status As Byte) As Integer
AngeloRTV_Set_GPIO_Int_Logic(ByVal PortNo As Integer,
    ByVal Logic As Integer) As Integer
AngeloRTV_Write_EEPROM (ByVal PortNo As Integer,
    ByVal Offset As Byte, ByVal Value As Byte)
    As Integer
AngeloRTV_Read_EEPROM (ByVal PortNo As Integer,
    ByVal Offset As Byte, ByRef Value As Byte)
    As Integer
AngeloRTV_Set_LED_Sts (ByVal PortNo As Integer,
    ByVal LEDStatus As Byte) As Integer
```

Delphi (Windows 98/NT/2000/XP)

```
AngeloRTV_Set_GPIO_Sts (PortNo:Smallint;status:Byte):Smallint;
AngeloRTV_Get_GPIO_Sts (PortNo:Smallint;var status:Byte):Smallint;
AngeloRTV_Set_GPIO_Int_Logic(PortNo:Smallint; Logic:Smallint):Smallint;
AngeloRTV_Write_EEPROM ( PortNo:Smallint;Offset:Byte;Value:Byte):Smallint;
AngeloRTV_Read_EEPROM ( PortNo:Smallint; Offset:Byte;var Value:Byte):Smallint;
```

```
AngeloRTV_Set_LED_Sts (PortNo:Smallint; LEDSta-  
tus:Byte):Smallint;
```

@ Argument

PortNo:

Port number is the zero index of the Angelo series card. For example, if there are two PCI-RTV-24 Angelo cards (card 0, card 1) in the system, and each PCI-RTV-24 has four ports, the first port of card 0 is "0", and the first port of card 1 is "4."

Status:

The digital input or digital output status

- ▶ 0 Low
- ▶ 1 High

Logic:

The digital input interrupt condition

- ▶ 0: Active Low
- ▶ 1: Active High

Offset:

The offset address of the EEPROM. This parameter is valid between 0 and 127

Value: The value in Byte data type, this parameter is valid between 0 and 255.

LEDStatus:

Use the parameter to set the LED status.

- ▶ LEDStatus = 1: High
- ▶ LEDStatus = 0: Low

@ Return Code

- ▶ 0: ERROR_NoError
- ▶ -7: ERROR_Not_Initialized – Make sure the port has been initialized by “AngeloRTV_Initial”.
- ▶ -9: ERROR_Invalid_PortNo – Please input the correct “PortNo” parameter.
- ▶ -15: ERROR_Invalid_Address – a valid offset address is between 0 and 127

@ Example

<VC/BCB >

AngeloRTV_Set_GPIO_Sts –

AngeloRTV_Get_GPIO_Sts –

```
I16 Result;  
I16 PortNo = 0;  
U8 Status = 1;  
Result = AngeloRTV_Set_GPIO_Sts (PortNo, Status);  
Result = AngeloRTV_Get_GPIO_Sts (PortNo, & Status);
```

AngeloRTV_Set_GPIO_Int_Logic –

```
I16 Result;  
U16 PortNo = 0;  
U16 Logic = 0;  
Result = AngeloRTV_Set_GPIO_Int_Logic (PortNo,  
Logic);
```

AngeloRTV_Write_EEPROM

AngeloRTV_Read_EEPROM

```
I16 Result;  
I16 PortNo = 0;  
U8 Offset = 0;  
U8 Value = 128;  
Result = AngeloRTV_Write_EEPROM (PortNo, Offset,  
Value);  
Result = AngeloRTV_Read_EEPROM (PortNo, Offset,  
&Value);
```

AngeloRTV_Set_LED_Sts –

```
I16 Result;  
U16 PortNo;  
U8 LEDStatus;  
PortNo = 0;  
LEDStatus = 1;
```

```
Result = AngeloRTV_Set_LED_Sts (PortNo, LEDSta-
tus);
```

< Visual Basic >

AngeloRTV_Set_GPIO_Sts -

AngeloRTV_Get_GPIO_Sts -

```
Dim Result As Integer
```

```
Dim PortNo As Integer
```

```
Dim Status As Byte
```

```
PortNo = 0
```

```
Status = 1
```

```
Result = AngeloRTV_Set_GPIO_Sts (ByVal PortNo,
ByVal Status)
```

```
Result = AngeloRTV_Get_GPIO_Sts (ByVal PortNo,
ByRef Status)
```

AngeloRTV_Set_GPIO_Int_Logic -

```
Dim Result As Integer
```

```
Dim PortNo As Integer
```

```
Dim Logic As Integer
```

```
PortNo = 0
```

```
Logic = 0
```

```
Result = AngeloRTV_Set_GPIO_Int_Logic (ByVal
PortNo, ByVal Logic)
```

AngeloRTV_Write_EEPROM

AngeloRTV_Read_EEPROM

```
Dim Result As Integer
```

```
Dim PortNo As Integer
```

```
Dim Offset As Byte
```

```
Dim Value As Byte
```

```
PortNo = 0
```

```
Offset = 0
```

```
Value = 128
```

```
Result = AngeloRTV_Write_EEPROM(ByVal PortNo,
ByVal Offset, ByVal Value)
```

```
Result = AngeloRTV_Read_EEPROM(ByVal PortNo,
ByVal Offset, ByRef Value)
```

AngeloRTV_Set_LED_Sts -

```
Dim Result As Integer
```

```
Dim PortNo As Integer
```

```
Dim LEDStatus As Byte
```

```
PortNo = 0
```

```
LEDStatus = 1
```

```
Result = AngeloRTV_Set_LED_Sts (ByVal PortNo,
ByVal LEDStatus)
```

<Delphi >

AngeloRTV_Set_GPIO_Sts –

AngeloRTV_Get_GPIO_Sts –

```
Var
Result : SmallInt;
PortNo : SmallInt;
Status: Byte;
PortNo:=0;
Status:=1;
Result := AngeloRTV_Set_GPIO_Sts (PortNo, Sta-
tus);
Result := AngeloRTV_Get_GPIO_Sts (PortNo, Sta-
tus);
```

AngeloRTV_Set_GPIO_Int_Logic –

```
var
Result: SmallInt;
PortNo: SmallInt;
Logic: SmallInt;
PortNo := 0;
Logic := 0;
Result := AngeloRTV_Set_GPIO_Int_Logic (PortNo,
Logic);
```

AngeloRTV_Write_EEPROM

AngeloRTV_Read_EEPROM

```
Var
Result : SmallInt;
PortNo : SmallInt;
Offset: Byte;
Value: Byte;
PortNo:=0;
Offset:=0;
Value:=128;
Result := AngeloRTV_Write_EEPROM (PortNo, Offset,
Value);
Result := AngeloRTV_Read_EEPROM (PortNo, Offset,
Value);
```

AngeloRTV_Set_LED_Sts –

```
var
Result: Smallint;
PortNo: Smallint;
LEDStatus: Byte;
PortNo := 0;
LEDStatus := 1;
```

```
Result := AngeloRTV_Set_LED_Sts (PortNo, LEDSta-  
tus);
```

5.7 Callback & Thread Functions

@ Name

AngeloRTV_Get_Int_Status (PortNo, IntStatus)

Gets the current interrupt status

AngeloRTV_Set_Int_Event (PortNo, hEvent)

Assigns the windows interrupt event

AngeloRTV_Set_Callback(PortNo, CallbackProc)

Sets the callback function when an interrupt is generated

@ Description

AngeloRTV_Get_Int_Status:

Allows users to identify what caused an interrupt signal.

- ▶ Bit 0: GPIO interrupt, when Digital input channel is changed.
- ▶ Bit 1: Channel 0 Image ready
- ▶ Bit 2: Channel 1 Image ready
- ▶ Bit 3: Channel 2 Image ready
- ▶ Bit 4: Channel 3 Image ready

Note: There are four channels in each port, the default channel is channel 0.

AngeloRTV_Set_Int_Event:

Links interrupt events. Users only have to declare the “hEvent” variable and call this function to DLL, the DLL will link the event and interrupt automatically.

AngeloRTV_Set_Callback:

Links the callback function when an interrupt is generated to host pc.

Note: There are two ways to use the synchronization mechanism, one is the callback function, and the other is the thread function.

@ Syntax

C/C++ (Windows 98/NT/2000/XP/CE.NET)

```
int AngeloRTV_Get_Int_Status(U16 PortNo, U32 *IntStatus);
```

```
I16 AngeloRTV_Set_Int_Event(U16 PortNo, HANDLE*
hEvent);
I16 AngeloRTV_Set_Callback (U16 PortNo, void (
__stdcall *CallBackProc)(U32 VideoBufferad-
dress ,U16 PortNo));
```

Visual Basic (Windows 98/NT/2000/XP/CE.NET)

```
AngeloRTV_Set_Int_Event (ByVal PortNo As Integer,
ByRef hEvent As Long) As Integer
AngeloRTV_Get_Int_Status(ByVal PortNo As Integer,
ByRef IntStatus As Long) As Integer
AngeloRTV_Set_Callback(ByVal PortNo As Integer,
ByVal CallBack As Long) As Integer
```

Delphi (Windows 98/NT/2000/XP)

```
AngeloRTV_Set_Int_Event (PortNo:Smallint;var hEv-
ent:Integer):Smallint;
AngeloRTV_Get_Int_Status (PortNo:Smallint;var
IntStatus:Longint):Smallint;
AngeloRTV_Set_Callback (PortNo:Smallint;lpCall-
BackProc:CallbackFunc):Smallint;
```

@ Argument

PortNo:

Port number is the zero index of the Angelo series card. For example, if there are two PCI-RTV-24 Angelo cards (card 0, card 1) in the system, and each PCI-RTV-24 has four ports, the first port of card 0 is "0", and the first port of card 1 is "4."

IntStatus:

Interrupt status

- ▶ Bit 0:GPIO interrupt, when Digital input channel is changed.
- ▶ Bit 1:Channel 0 Image ready
- ▶ Bit 2:Channel 1 Image ready
- ▶ Bit 3:Channel 2 Image ready
- ▶ Bit 4:Channel 3 Image ready

hEvent:

Interrupt event handle.

@ Return Code

- ▶ 0: ERROR_NoError
- ▶ -7: ERROR_Not_Initialized – Make sure the port has been initialized by “AngeloRTV_Initial”.
- ▶ -9: ERROR_Invalid_PortNo – Please input the correct “PortNo” parameter.

@ Example

< VC/BCB >

Use Thread:

```
HANDLE hEvent=NULL;
void *pThread=NULL;
U32 threadID;
U16 PortNo = 0;

DWORD nObj;
U32 Size_Byte;
U32 Status =0;
I16 ISR_ON=0;
DWORD WINAPI IntThreadProc( LPVOID lpParam )
{
    while( ISR_ON )
    {
        nObj = WaitForSingleObject(hEvent, INFI-
NITE);
        AngeloRTV_Get_Int_Status(PortNo, &Status);
        if((Status&0x01)==1)//GPIO
        {
        }
        if((Status>>1&0x01)==1)//Channel 0 of the
nPort
        {
        }
        else if((Status>>2&0x01)==1)//Channel 1 of
the nPort
        {
        }
        else if((Status>>3&0x01)==1)//Channel 2 of
the nPort
        {
        }
    }
}
```

```

else if((Status>>4&0x01)==1)//Channel 3 of
the nPort
{
}
ResetEvent(hEvent);
}
Return TRUE;
}
AngeloRTV_Set_Int_Event(PortNo,&hEvent);
pThread =CreateThread(NULL, 0, IntThreadProc, 0,
0, &threadID);

```

Use Callback Function:

```

U16 PortNo = 0;
void __stdcall MediaStreamProc( U32
VideoBufferaddress ,U16 PortNo)
{
U32 Status;
AngeloRTV_Get_Int_Status(PortNo,&Status);
if((Status&0x01)==1)//GPIO
{
}
if((Status>>1&0x01)==1)//Channel 0 of the
nPort
{
}
else if((Status>>2&0x01)==1)//Channel 1 of
the nPort
{
}
else if((Status>>3&0x01)==1)//Channel 2 of
the nPort
{
}
else if((Status>>4&0x01)==1)//Channel 3 of
the nPort
{
}
}
AngeloRTV_Set_Callback(PortNo,MediaStreamProc);

```

< Visual Basic >

Use Callback Function

```

Dim Result As Integer
Dim PortNo As Integer

```



```

Public Sub lpcallback(ByVal VideoBufferaddress As
    Long, ByVal PortNo As Integer)
Dim Status As Long
Result = AngeloRTV_Get_Int_Status(PortNo, Sta-
    tus)
End Sub
PortNo = 0
Result = AngeloRTV_Set_Callback(PortNo, AddressOf
    lpcallback)

```

<Delphi >

Use Thread

```

Var
ISR_ON : SmallInt;
Event_Angelo:Integer;
ThreadId : LongInt;
PortNo: SmallInt;
PortNo:=0;
    function ThreadFunc(Parameter: Pointer):
        Integer ;
        var
            Str_Add :Pointer;
            Size_Byte :Longint;
            intstatus : LongInt;
begin
    while(ISR_ON=1) do
        begin
            WaitForSingleOb-
                ject(Event_Angelo,INFINITE);
            ResetEvent(Event_Angelo);

            AngeloRTV_Get_Int_Status(PortNo,intstatus);
            if intstatus = 2 then //image
                ready for channel 0 of port
                begin
                    end;
                end;
        end;
    end;

    AngeloRTV_Set_Int_Event(PortNo,Event_Angelo
    );
    ISR_ON :=1;

```

```
Mythread := BeginThread(nil,0,Thread-  
Func,nil,0,ThreadId);
```

Use Callback function

```
var  
PortNo: SmallInt;  
PortNo:=0;  
procedure MyCallback(VideoBufferAddress : Long-  
Int;PortNo : SmallInt);stdcall  
var  
Str_Add :Pointer;  
Result :Smallint;  
Size_Byte :LongInt;  
intstatus :LongInt;  
begin  
AngeloRTV_Get_Int_Status(PortNo,intstatus);  
if intstatus = 2 then  
begin  
end;  
end;  
AngeloRTV_Set_Callback(Cur_Port,MyCallback);
```

5.8 Watchdog Timer

Note: This function is only available for RTV-24.

@ Name

AngeloRTV_Set_WDT(CardNo, Enable, Interval)

Sets the watch dog status(Only for PCI-RTV24)

@ Description

AngeloRTV_Set_WDT:

Enables or disables the watch dog timer in the Angelo series cards, and set the interval of timer. When users have enabled the watch dog timer and selected a 16 seconds interval, a system reset signal will be triggered if this function is not called after 16 seconds.

@ Syntax

C/C++ (Windows 98/NT/2000/XP/CE.NET)

```
U16 AngeloRTV_Set_WDT (U16 CardNo,U16 Enable,U16  
Interval)
```

Visual Basic (Windows 98/NT/2000/XP/CE.NET)

```
AngeloRTV_Set_WDT (ByVal PortNo As Integer, ByVal  
Enable As Integer, ByVal Interval As Integer) As Integer
```

Delphi (Windows 98/NT/2000/XP)

```
AngeloRTV_Set_WDT(CardNo:Smallint;enable:Small-  
int;interval:Smallint):Smallint;
```

@ Argument

CardNo:

Card number is the zero index in Angelo series card. For example, if there are two Pci-RTV-24 Angelo cards (card 0, card 1) in the system, "CardNo" of card 0 is 0, and 1 for card 1.

Enable:

Enables or disables the watch dog timer. 0 for disable, 1 for enable.

Interval:

Indicates the watch dog timer interval.

- ▶ 1: 8 seconds
- ▶ 2: 16 seconds
- ▶ 3: 32 seconds

@ Return Code

- ▶ 0 : ERROR_NoError
- ▶ -7: ERROR_Not_Initialized – Make sure the port has been initialized by “AngeloRTV_Initial”.
- ▶ -9 : ERROR_Invalid_PortNo – Please input the correct “PortNo” parameter.

@ Example

<VC/BCB >

AngeloRTV_Set_WDT

```
I16 Result;  
U16 CardNo = 0;  
U16 Enable = 1;  
U16 Interval = 1;  
Result = AngeloRTV_Set_WDT(CardNo,Enable,Inter-  
val);
```

<Visual Basic >

AngeloRTV_Set_WDT

```
Dim Result As Integer  
Dim CardNo As Integer  
Dim Enable As Integer  
Dim Interval As Integer  
CardNo = 0  
Enable = 1  
Interval = 1  
Result = AngeloRTV_Set_WDT(CardNo,Enable,Inter-  
val)
```

<Delphi >

AngeloRTV_Set_WDT

```
Var  
Result : SmallInt;  
CardNo: SmallInt;  
Enable: SmallInt;  
Interval: SmallInt;  
CardNo :=0;  
Enable:=1;
```

```
Interval:=1;  
Result := AngeloRTV_Set_WDT(CardNo,Enable,Inter-  
val);
```

5.9 Software Trigger

@ Name

AngeloRTV_Trigger_Config (PortNo,Interval)

Sets software trigger configuration(Only for PCI-RTV24, cPCI-RTV-24, cPCI-RTV44)

AngeloRTV_Trigger_Start (CardNo, Multiplex)

Generates single or multiple trigger output simultaneously(Only for PCI-RTV24, cPCI-RTV-24, cPCI-RTV44)

@ Description

AngeloRTV_Trigger_Config:

Configures the pulse output interval.

AngeloRTV_Trigger_Start:

Generates a one shot pulse output for single or multiple ports.

@ Syntax

C/C++ (Windows 98/NT/2000/XP/CE.NET)

```
I16 AngeloRTV_Trigger_Config(U16 PortNo,U16 Interval);  
I16 AngeloRTV_Trigger_Start(U16 CardNo,U16 Multiplex);
```

Visual Basic (Windows 98/NT/2000/XP/CE.NET)

```
AngeloRTV_Trigger_Config (ByVal PortNo As Integer, ByVal Interval As Integer) As Integer  
AngeloRTV_Trigger_Start (ByVal CardNo As Integer, ByVal Multiplex As Integer) As Integer
```

Delphi (Windows 98/NT/2000/XP)

```
AngeloRTV_Trigger_Config (PortNo:Smallint; Interval:Smallint):Smallint;  
AngeloRTV_Trigger_Start (CardNo:Smallint; Multiplex:Smallint):Smallint;
```

@ Argument

CardNo:

Card number is the zero index in Angelo series card. For example, if there are two Pci-RTV-24 Angelo cards (card 0, card 1) in the system, "CardNo" of card 0 is 0, and 1 for card 1.

PortNo:

Port number is the zero index of the Angelo series card. For example, if there are two PCI-RTV-24 Angelo cards (card 0, card 1) in the system, and each PCI-RTV-24 has four ports, the first port of card 0 is “0”, and the first port of card 1 is “4.”

Interval:

Indicates the trigger output interval, the valid range is from 0 to 253, the definition is as following

- ▶ 0: 16ms
- ▶ 32: 12ms
- ▶ 128: 8ms
- ▶ 253: 60μs

Multiplex:

Indicates the trigger output ports in Angelo series cards.

- ▶ Bit 0: Port 0 on each card. 0 for disable, 1 for enable.
- ▶ Bit 1: Port 1 on each card. 0 for disable, 1 for enable.
- ▶ Bit 2: Port 2 on each card. 0 for disable, 1 for enable.
- ▶ Bit 3: Port 3 on each card. 0 for disable, 1 for enable.

For example:

- ▶ Multiplex = 1, only port 0 in each Angelo series card generates a trigger output.
- ▶ Multiplex = 2, only port 1 in each Angelo series card generates a trigger output.
- ▶ Multiplex = 15, four ports in each Angelo series card generates a trigger output.

@ Return Code

- ▶ 0: ERROR_NoError
- ▶ -7: ERROR_Not_Initialized – Make sure the port has been initialized by “AngeloRTV_Initial”.
- ▶ -9: ERROR_Invalid_PortNo – Please input the correct “PortNo” parameter.

@ Example

<VC/BCB >

AngeloRTV_Trigger_Config

AngeloRTV_Trigger_Start

```
I16 Result;  
U16 CardNo = 0;  
U16 PortNo = 0;  
U16 Multiplex = 1;  
U16 Interval = 32;  
Result = AngeloRTV_Trigger_Config(PortNo, Inter-  
val);  
Result = AngeloRTV_Trigger_Start(CardNo, Multi-  
plex);
```

< Visual Basic >*AngeloRTV_Trigger_Config**AngeloRTV_Trigger_Start*

```
Dim Result As Integer  
Dim CardNo As Integer  
Dim PortNo As Integer  
Dim Multiplex As Integer  
Dim Interval As Integer  
CardNo = 0  
PortNo = 0  
Multiplex = 1  
Interval = 32  
Result = AngeloRTV_Trigger_Config (PortNo, Inter-  
val)  
Result = AngeloRTV_Trigger_Start (CardNo, Multi-  
plex)
```

< Delphi >*AngeloRTV_Trigger_Config**AngeloRTV_Trigger_Start*

```
Var  
Result : SmallInt;  
CardNo: SmallInt;  
PortNo: SmallInt;  
Multiplex: SmallInt;  
Interval: SmallInt;  
CardNo :=0;  
PortNo:=0;  
Multiplex:=1;  
Interval:=32;  
Result := AngeloRTV_Trigger_Config (PortNo, Inter-  
val);  
Result := AngeloRTV_Trigger_Start (CardNo, Multi-  
plex);
```

5.10 Frame Buffer

@ Name

AngeloRTV_Copy_frame (PortNo, Dest_Address, Size_Byte)

Copies the frame data to the user allocated destination memory (bytes).

AngeloRTV_Get_frame(PortNo, Start_Address,Width, Height, Size_Byte)

Gets the frame memory start address and size of frame (bytes).

AngeloRTV_Save_File(PortNo, FileName, FileFormat, nQuality)

Save the video frame into an image file.

@ Description

AngeloRTV_Copy_frame:

Copies frame data to memory or an array that the user has allocated. Before using this function, remember to allocate enough memory address space or array elements.

AngeloRTV_Save_File:

Saves the current video frame into an image file (TIF, BMP, or JPEG). nQuality is only used JPEGs.

AngeloRTV_Get_frame:

Retrieves the memory start address from the frame data, width, height, and size in bytes of the image. For example a FULL NTSC RGB24 video frame will occupy 900K Byte (640*480*3) memory address space.

Format	DWORD(32Bit)	Pixel Data			
		Byte 3 Bit [31:24]	Byte 2 Bit[23:16]	Byte 1 Bit[15:8]	Byte 0 Bit[7:0]
RGB32	Dw0	Appha	R	G	B
RGB24	Dw0	B1	R0	G0	B0
	Dw1	G2	B2	R1	G1
	Dw2	R3	G3	B3	R2

Table 5-3: Pixel Data

Format	DWORD(32Bit)	Pixel Data			
RGB16	Dw0	{R0[31:27], G0[26:21], B0[20:16]}	{R0[15:11], G0[10:5], B0[4:0]}		
RGB15	Dw0	{0,R0[30:26], G0[25:21], B0[20:16]}	{0,R0[14:10], G0[9:5], B0[4:0]}		
Gray Scale(Y8)	Dw0	Y3	Y2	Y1	Y0

Table 5-3: Pixel Data

@ Syntax

C/C++ (Windows 98/NT/2000/XP/CE.NET)

```

I16      AngeloRTV_Copy_Frame(U16      PortNo,U8
      *Dest_Address,U32 Size_Byte);
I16      AngeloRTV_Get_Frame(U16      PortNo,U32*
      Start_Address, U32* Width, U32* Height, U32*
      Size_Byte);
16 AngeloRTV_Save_File(U16 PortNo, char* File-
      Name,U8 FileFormat,U32 nQuality);

```

Visual Basic (Windows 98/NT/2000/XP/CE.NET)

```

AngeloRTV_Copy_Frame (ByVal PortNo As Integer,
      Dest_Address As Byte, ByVal Size_byte As
      Long) As Integer
AngeloRTV_Get_Frame (ByVal PortNo As Integer,
      ByRef Start_Address As Long, ByRef Width as
      Long, ByRef Height As Long, ByRef Size_byte
      As Long) As Integer
AngeloRTV_Save_File (ByVal PortNo As Integer,
      ByVal FileName As String, ByVal FileFormat
      As Byte, ByVal nQuality As Long) As Integer

```

Delphi (Windows 98/NT/2000/XP)

```

AngeloRTV_Copy_Frame (PortNo:Smallint;var
      Dest_Address:Byte;Size_byte:Longint):Small-
      int;
AngeloRTV_Get_Frame (PortNo:Smallint;var
      Start_Address:Pointer; var Width:Longint ,
      var Height:Longint ,var Size_byte:Long-
      int):Smallint;
AngeloRTV_Save_File (PortNo:Smallint;File-
      Name:String;FileFormat:Byte;nQuality :Long-
      Ing):Smallint;

```

@ Argument

PortNo:

Port number is the zero index of the Angelo series card. For example, if there are two PCI-RTV-24 Angelo cards (card 0, card 1) in the system, and each PCI-RTV-24 has four ports, the first port of card 0 is "0", and the first port of card 1 is "4."

Dest_Address:

User allocated destination memory address or array.

Start_Address:

Memory start address of the video frame.

Width:

Image width.

Height:

Image height.

Size_Byte:

Memory size in bytes.

FileName:

File name to save to. Remember to add the file extension name.

FileFormat:

File format to save to.

- ▶ 0: TIF
- ▶ 1: BMP
- ▶ 2: JPEG

nQuality:

This parameter is used only for the JPEG file format.

@ Return Code

- ▶ 0: ERROR_NoError
- ▶ -7: ERROR_Not_Initialized – Make sure the port has been initialized by “AngeloRTV_Initial”.
- ▶ -9: ERROR_Invalid_PortNo – Please input a correct “PortNo” parameter.

@ Example

<VC/BCB >

AngeloRTV_Copy_Frame

```

I16 Result;
U16 PortNo = 0;
U32 Size_Byte = 640*480*3;
U8* Dest_Address =NULL;
Dest_Address = (U8*)malloc(Size_Byte );
Result      =      AngeloRTV_Copy_Frame      (PortNo,
      Dest_Address, Size_Byte);

```

AngeloRTV_Get_Frame

```

I16 Result;
U16 PortNo = 0;
U32 Size_Byte,Width,Height ;
U32 StrAddr ;
Result      =      AngeloRTV_Get_Frame(PortNo,&StrAddr,
      &Width, &Height,&Size_Byte);

```

AngeloRTV_Save_File

```

I16 Result;
U16 PortNo = 0;
U8 File_Format = 2;
U32 nQuality = 25;
Result      =      AngeloRTV_Save_File(PortNo,“Image.jpg”,
      File_Format, nQuality);

```

< Visual Basic >

AngeloRTV_Copy_Frame

```

Dim Result As Integer
Dim PortNo As Integer
Dim Size_Byte As Long
Dest_Address( ) As Byte
PortNo = 0
Size_Byte =640*480*3
ReDim Dest_Address(0 To Size_Byte - 1) As Byte
Result      =      AngeloRTV_Copy_Frame      (PortNo,
      Dest_Address(0), Size_Byte);

```

AngeloRTV_Get_Frame

```

Dim Result As Integer
Dim PortNo As Integer
Dim Size_Byte As Long
Dim StrAddr As Long
Dim Width as Long,Height As Long
PortNo = 0
Result = AngeloRTV_Get_Frame( ByVal PortNo,
    Str_Add, Width, Height, Size_Byte)

```

AngeloRTV_Save_File

```

Dim Result As Integer
Dim File_Format as Byte
Dim nQuality as Long
PortNo = 0
File_Format = 2
NQuality = 25
Result = AngeloRTV_Save_File (PortNo,
    "Image.jpg", File_Format, NQuality)

```

<Delphi >

AngeloRTV_Copy_Frame

```

Var
Result : SmallInt;
PortNo: SmallInt;
Size_Byte :Longint;
Dest_Add : array of Byte;
PortNo := 0;
Size_Byte := 640*480*3;
SetLength(Dest_Add, Size_Byte);
Result := AngeloRTV_Copy_Frame (PortNo,
    Dest_Add[0], Size_Byte);

```

AngeloRTV_Get_Frame

```

Var
Result : SmallInt;
PortNo: SmallInt;
Size_Byte : LongInt;
Width :LongInt;
Height :LongInt;
Str_Add :Pointer;
PortNo:=0;
Result :=AngeloRTV_Get_Frame (PortNo,
    Str_Add,Width, Height, Size_Byte);

```

AngeloRTV_Save_File

```

Var

```

```
Result : SmallInt;  
PortNo: SmallInt;  
File_Format : Byte;  
NQuality :LongInt;  
PortNo:=0;  
File_Format:=2;  
Nquality := 25;  
Result      :=      AngeloRTV_Save_File      (PortNo,  
      'Image.jpg', File_Format, Nquality)
```

6 Appendix

6.1 Glossary

Brightness:

Attribute of a visual sensation according to which an area appears to exhibit more or less light

CCIR:

An acronym to designate a scanning system used in Europe. The CCIR system is made of two interlaced fields of 312.5 lines, for a total of 625 lines. In each field, only 287.5 lines are visible, for a total of 575 visible lines. A line lasts 64 ms, of which approximately 52 ms are conveying visible pixels.

Composite Video:

Composite video (CVS/CVBS) signal carries video picture information for color, brightness and synchronizing signals for both horizontal and vertical scans.

CIF:

CIF has 352(H) x 288(V) luminance pixels, and 176(H) x 144(V) chrominance pixels. QCIF is a similar picture format with one-quarter the size of CIF.

EIA:

An acronym to designate a scanning system used in America and Japan. The EIA system is made of two interlaced fields of 262.5 lines, for a total of 525 lines. In each field, only 242.5 lines are visible, for a total of 485 visible lines (typical value). A line lasts 63.56 ms, of which approximately 52 ms are conveying visible pixels.

Field:

For interlaced video the total picture is divided into two fields, one even and one odd, each containing one half of the total vertical information. Each field takes one sixtieth of a second (one fiftieth for PAL) to complete. Two fields make a complete frame of video.

Frame:

One frame (two fields) of video contains the full vertical interlaced information content of the picture. For NTSC this consists of 525 lines and PAL a frame is consisted of 625 lines.

Gamma:

Cathode ray tubes (CRTs) do not have a linear relationship between brightness and the input voltage applied. To compensate for this non-linearity, a pre distortion or gamma correction is applied, generally at the camera source. A value of gamma equal to 2.2 is typical, but can vary for different CRT phosphors.

Hue:

Attribution of visual sensation according to which area appears to be similar to one, or proportions of two, of the perceived colors red, yellow, green, and blue.

NTSC:

Acronym to designate a color television broadcast standard used in America and Japan. The (M) NTSC system uses 525 lines per frame (2 interlaced fields), a 29.97 frame per second update rate, and a YIQ or RGB color space. In each field, only 242.5 lines are visible, for a total of 485 visible lines (typical value). A line lasts 63.56 ms, of which approximately 52 ms are conveying visible pixels.

PAL:

Acronym to designate a color television broadcast standard used in Europe. The (B, G, H, I) PAL (or Phase Alternation Line) uses 625 lines per frame (2 interlaced fields), a 25 frame per second update rate, and the RGB color space. In each field, only 287.5 lines are visible, for a total of 575 visible lines. A line lasts 64 ms, of which approximately 52 ms are conveying visible pixels.

Saturation:

A characteristic describing color amplitude or intensity. A color of a given hue may consist of low or high saturation value, which relates to the vividness of color.

6.2 Standards Compliance



Notice for USA
Compliance Information Statement
(Declaration of Conformity Procedure)
DoC FCC Part 15

This equipment has been tested and found to comply with the limits for a Class A digital device, pursuant to Part 15 of the FCC Rules.

These limits are designed to provide reasonable protection against harmful interference in a residential installation or when the equipment is operated in a commercial environment.

This equipment generates, uses and can radiate radio frequency energy and, if not installed and used in accordance with the instructions, may cause harmful interference to radio communications. However, there is no guarantee that interference will not occur in a particular installation.

If this equipment does cause harmful interference to radio or television reception, which can be determined by turning the equipment off and on, the user is encouraged to try to correct the interference by one or more of the following measures:

- ▶ Reorient or relocate the receiving antenna.
- ▶ Increase the separation between the equipment and receiver.
- ▶ Connect the equipment into an outlet on a circuit different from that to which the receiver is connected.
- ▶ Consult the dealer or an experienced radio/TV technician for help.

**Notice for Europe**

This product is in conformity with the
Council Directive 89/336/EEC
amended by 92/31/EEC and 93/68/EEC

This equipment has been tested and found to comply with EN55022/CISPR22 and EN55024/CISPR24. To meet EC requirements, shielded cables must be used to connect a peripheral to the card. This product has been tested in a typical class B compliant host system. It is assumed that this product will also achieve compliance in any class A compliant unit.

Warranty Policy

Thank you for choosing ADLINK. To understand your rights and enjoy all the after-sales services we offer, please read the following carefully.

1. Before using ADLINK's products please read the user manual and follow the instructions exactly. When sending in damaged products for repair, please attach an RMA application form which can be downloaded from: <http://rma.adlinktech.com/policy/>.
2. All ADLINK products come with a two-year guarantee:
 - ▶ The warranty period starts from the product's shipment date from ADLINK's factory.
 - ▶ Peripherals and third-party products not manufactured by ADLINK will be covered by the original manufacturers' warranty.
 - ▶ For products containing storage devices (hard drives, flash cards, etc.), please back up your data before sending them for repair. ADLINK is not responsible for loss of data.
 - ▶ Please ensure the use of properly licensed software with our systems. ADLINK does not condone the use of pirated software and will not service systems using such software. ADLINK will not be held legally responsible for products shipped with unlicensed software installed by the user.
 - ▶ For general repairs, please do not include peripheral accessories. If peripherals need to be included, be certain to specify which items you sent on the RMA Request & Confirmation Form. ADLINK is not responsible for items not listed on the RMA Request & Confirmation Form.

3. Our repair service is not covered by ADLINK's two-year guarantee in the following situations:
 - ▶ Damage caused by not following instructions in the user's manual.
 - ▶ Damage caused by carelessness on the user's part during product transportation.
 - ▶ Damage caused by fire, earthquakes, floods, lightning, pollution, other acts of God, and/or incorrect usage of voltage transformers.
 - ▶ Damage caused by unsuitable storage environments (i.e. high temperatures, high humidity, or volatile chemicals).
 - ▶ Damage caused by leakage of battery fluid during or after change of batteries by customer/user.
 - ▶ Damage from improper repair by unauthorized technicians.
 - ▶ Products with altered and/or damaged serial numbers are not entitled to our service.
 - ▶ Other categories not protected under our warranty.
4. Customers are responsible for shipping costs to transport damaged products to our company or sales office.
5. To ensure the speed and quality of product repair, please download an RMA application form from our company website: <http://rma.adlinktech.com/policy>. Damaged products with attached RMA forms receive priority.

If you have any further questions, please email our FAE staff: service@adlinktech.com.