

Operation Manual
Thorlabs Instrumentation
Optical Power Meter

PM100A



2009

Version: 17655-D02 REV A
Date: 24.04.2009

Contents	page
1 General Information	5
1.1 Safety	6
1.2 Ordering Codes and Accessories	8
2 Getting Started	9
3 Unpacking	9
3.1 Preparation	9
3.2 Physical Overview	10
3.2.1 Front Panel	10
3.2.2 Side Panel	10
3.2.3 Rear Panel	11
3.2.4 Bottom	11
3.2.5 Display	12
4 Operating the PM100A	13
4.1 Connecting a Power Sensor	13
4.2 Controlling the PM100A	13
4.2.1 Navigating the Menu	13
4.2.2 System Settings	13
4.2.3 Power Measurement	15
4.2.3.1 Range and Scale Control	15
4.2.3.2 Wavelength Correction	15
4.2.3.3 Zeroing	16
4.2.3.4 Setting an Attenuation / Gain Factor	17
4.2.3.5 Relative Power Measurement	18
4.2.4 Display Options	18
4.2.5 Sensor Dependent Functions	19
4.2.5.1 Photodiode Sensors	19
4.2.5.2 Thermal Power Sensors	20
4.3 Analog Output	22
4.4 Tune Sound	22
4.5 Battery Charging	23
5 Measurement Considerations	24
5.1 Choosing the right Sensor	24
5.2 Reducing Noise for High Accuracy Measurements	24
5.3 Power Measurement of Pulsed Signals	25
5.4 Line width of Light Sources	25
5.5 Temperature Effects on Thermal Sensors	25
5.6 Ambient and Stray Light	26
5.7 Back Reflection	26

5.8 Beam Diameter vs. Active Sensor Area	26
5.9 Fiber Based Measurements	27
6 Computer Interface	28
6.1 PM100 Utility Software	28
6.1.1 Front Panel	29
6.1.2 Description of the Front Panel Elements:	29
6.2 Firmware Update	32
6.3 Simple LabVIEW Example using SCPI Commands	33
6.4 Using the Instrument Drivers	37
6.5 SCPI Commands	38
6.5.1 An Introduction to the SCPI language	38
6.5.2 IEEE488.2 Common Commands	41
6.5.2.1 Command summary	41
6.5.2.2 Command reference	42
6.5.2.3 PM100D specific SCPI Command Reference	43
6.6 Maintenance and Repair	53
6.7 Maintenance	53
6.8 Troubleshooting	54
7 Appendix	55
7.1 Warranty	55
7.2 Certifications and compliances	56
7.3 Technical data	57
7.4 Pin Assignment of the Sensor Connector	59
7.5 Thorlabs 'End of Life' policy (WEEE)	60
7.5.1 Waste treatment on your own responsibility	60
7.5.2 Ecological background	61
7.6 List of figures	62
7.7 Addresses	63

We aim to develop and produce the best solution for your application in the field of optical measurement technique. To help us to live up to your expectations and develop our products permanently we need your ideas and suggestions. Therefore, please let us know about possible criticism or ideas. We and our international partners are looking forward to hearing from you.

Thorlabs

This part of the instruction manual contains every specific information on the PM100A handheld optical power meter. A general description is followed by explanations of how to operate the unit manually. You will also find information about a simple remote control of the unit.

Attention

This manual contains 'WARNINGS' and 'ATTENTION' labels in this form, to indicate danger for persons or possible damage to equipment.

Please read these advises carefully!

NOTE

This manual also contains 'NOTES' and 'HINTS' written in this form.

1 General Information

The PM100A Handheld Optical Power Meter is designed to measure the optical power of laser light or other monochromatic or near monochromatic light sources and the energy of pulsed light sources.

The space-saving, battery powered design and compatibility to all Thorlabs “C-Type” Photodiode, Thermal, Pyroelectric sensors, and custom Photodiode, Thermal and Pyroelectric detectors, featured with a fast USB device interface open a wide range of applications in Manufacturing, Quality Control, Quality Assurance, and R&D for stationary and field use.

The unit combines a precise 4 digit power readout with a mechanical, mirror supported analog needle meter to perform laser tuning tasks or watching trends.

Please refer to the user manual on the data carrier supplied with the unit for detailed function description.

The provided software, including drivers and applications for LabVIEW and C makes it easy to integrate the instrument in test and measurement systems.

A rechargeable lithium polymer battery allows long intervals between the charging cycles. The unit can be recharged with the supplied AC adapter or via USB connection to a PC or laptop.

1.1 Safety

Attention

All statements regarding safety of operation and technical data in this instruction manual will only apply when the unit is operated correctly.

The power meter PM100A must not be operated in explosion endangered environments!

Sensor, photodiode and control inputs and outputs must only be connected with duly shielded connection cables.

Only with written consent from Thorlabs may changes to single components be carried out or components not supplied by Thorlabs be used.

Do not remove covers!

Refer servicing to qualified personal!

Attention

Mobile telephones, cellular phones or other radio transmitters are not to be used within the range of three meters of this unit since the electromagnetic field intensity may then exceed the maximum allowed disturbance values according to IEC 61326-1.

This product has been tested and found to comply with the limits according to IEC 61326-1 for using connection cables shorter than 3 meters (9.8 feet).

Attention

The following statement applies to the products covered in this manual, unless otherwise specified herein. The statement for other products will appear in the accompanying documentation.

Note: This equipment has been tested and found to comply with the limits for a Class B digital device, pursuant to Part 15 of the FCC Rules and meets all requirements of the Canadian Interference-Causing Equipment Standard ICES-003 for digital apparatus. These limits are designed to provide reasonable protection against harmful interference in a residential installation. This equipment generates, uses, and can radiate radio frequency energy and, if not installed and used in accordance with the instructions, may cause harmful interference to radio communications. However, there is no guarantee that interference will not occur in a particular installation. If this equipment does cause harmful interference to radio or television reception, which can be determined by turning the equipment off and on, the user is encouraged to try to correct the interference by one or more of the following measures:

- Reorient or relocate the receiving antenna.
- Increase the separation between the equipment and receiver.
- Connect the equipment into an outlet on a circuit different from that to which the receiver is connected.
- Consult the dealer or an experienced radio/T.V. technician for help.

Thorlabs GmbH is not responsible for any radio television interference caused by modifications of this equipment or the substitution or attachment of connecting cables and equipment other than those specified by Thorlabs GmbH. The correction of interference caused by such unauthorized modification, substitution or attachment will be the responsibility of the user.

The use of shielded I/O cables is required when connecting this equipment to any and all optional peripheral or host devices. Failure to do so may violate FCC and ICES rules.

1.2 Ordering Codes and Accessories

Order Code	Description
PM100A	Handheld Power Meter Console

Photodiode Power Sensors:

Order Code	Type	Detector	Aperture mm	Wavelength nm	Power W
S120C	Compact Sensor	Si	Ø 9.5	400 - 1100	50n - 50m
S120VC	Compact Sensor	UV-Si	Ø 9.5	200 - 1100	50n - 50m
S121C	Compact Sensor	Si	Ø 9.5	400 - 1100	500n - 500m
S122C	Compact Sensor	Ge	Ø 9.5	700 - 1800	50n - 40m
S130C	Slim Sensor Dual Range	Si	Ø 9.5	400 - 1100	5n - 5m 500n - 500m
S130VC	Slim Sensor Dual Range	UV-Si	Ø 9.5	200 - 1100	5n - 5m 50n - 50m
S132C	Slim Sensor Dual Range	Ge	Ø 9.5	700 - 1800 1200 - 1800	5n - 5m 500n - 500m
S140C	Integr. Sphere (1")	Si	Ø 5.0	350 - 1100	1µ - 500m
S144C	Integr. Sphere (1")	InGaAs	Ø 5.0	800 - 1700	1µ - 500m
S142C	Integr. Sphere (2")	Si	Ø 12	350 - 1100	10µ - 20
S145C	Integr. Sphere (2")	InGaAs	Ø 12	800 - 1700	1µ - 3
S145C	Integr. Sphere (2")	InGaAs	Ø 12	800 - 1700	10µ - 20
S150C	Fiber Head	Si	3.6 x 3.6	350 - 1100	100p - 5m
S151C	Fiber Head	Si	3.6 x 3.6	400 - 1100	1n - 20m
S154C	Fiber Head	InGaAs	Ø 2.0	700 - 1700	100p - 5m
S155C	Fiber Head	InGaAs	Ø 2.0	700 - 1700	1n - 20m

Thermal Power Sensors:

Order Code	Type	Aperture mm	Wavelength nm	Power W
S302C	Thermally Stabilized Thermal Absorber	Ø 12	190 - 25000	100µ - 2
S310C	Thermal Surface Absorber	Ø 20	190 - 25000	10m - 10
S314C	Thermal Surface Absorber	Ø 25	190 - 10600	10m - 60
S322C	Thermal Surface Absorber	Ø 25	190 - 10600	100m - 250
S350C	Thermal Surface Absorber Excimer Coating	Ø 40	190 - 1100 and 10600	10m - 60
S370C	Thermal Volume Absorber for high peak power lasers	Ø 25	400 - 5200	10m - 15

Please visit our homepage <http://www.thorlabs.com> for various accessories like fiber adapters, posts and post-holders, data sheets and further information.

2 Getting Started

3 Unpacking

Inspect the shipping container for damage.

If the shipping container seems to be damaged, keep it until you have inspected the contents and you have inspected the PM100A mechanically and electrically.

Verify that you have received the following items within the hard-case:

1. PM100A power meter console
2. Plug-In power supply with Interchangeable primary plug for USA, UK, Europe, and Australia
3. USB cable, type 'A' to 'mini-B'
4. Quick-start guide
5. USB memory stick with instrument drivers, user application and operation manual
6. Certificate of Calibration

3.1 Preparation

Configure the plug-in power supply with the primary plug for your local power supply.

Connect a suitable power or energy sensor.

Turn the unit on by pressing the power button in the side panel.

After switching on the unit, the graphics display will show the device status and then jump to the last measurement screen before power down.

The PM100A is immediately ready to use after turning on.

3.2 Physical Overview

3.2.1 Front Panel

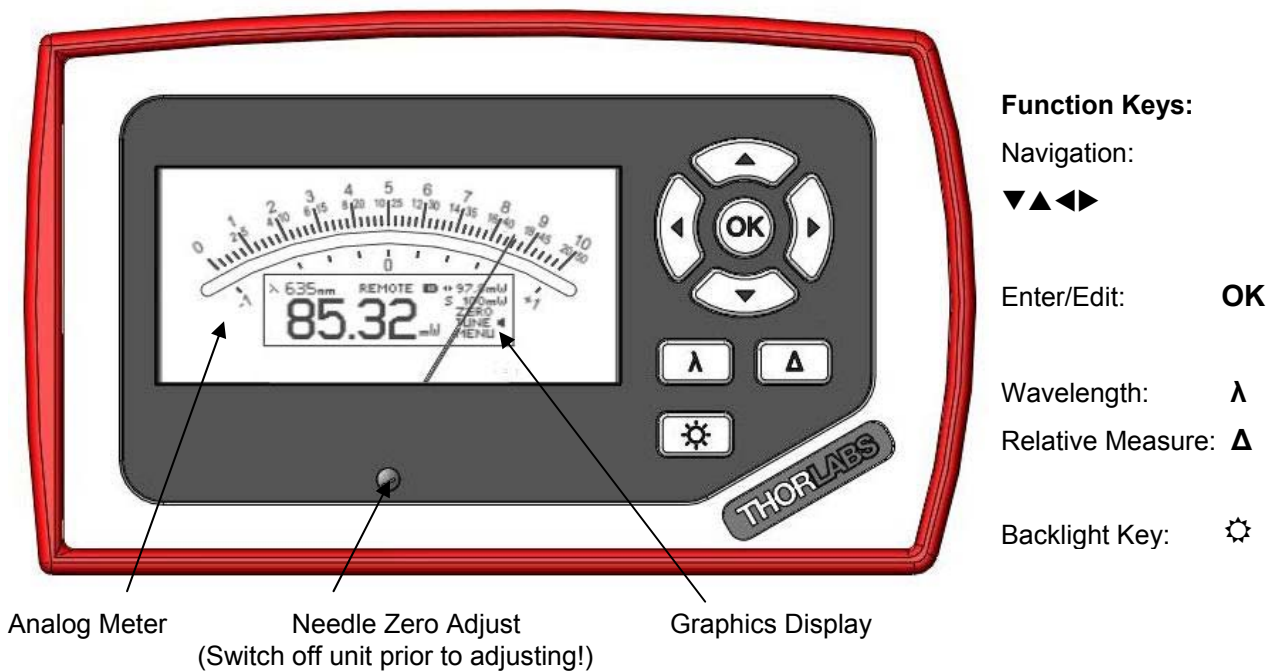

Figure 1 Physical Overview Front Panel

3.2.2 Side Panel

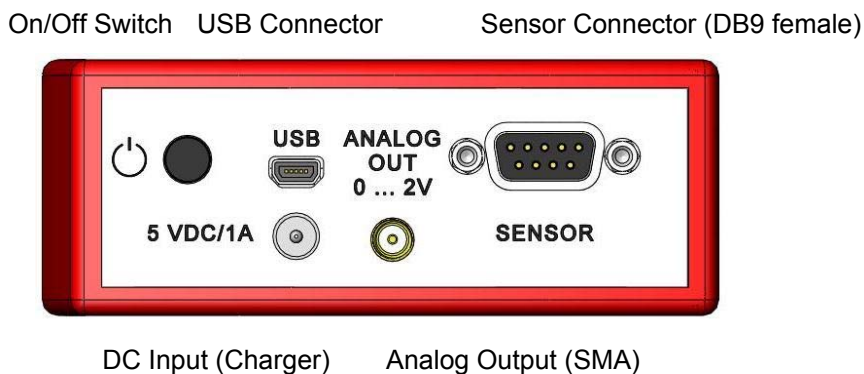

Figure 2 Physical Overview Side Panel

3.2.3 Rear Panel

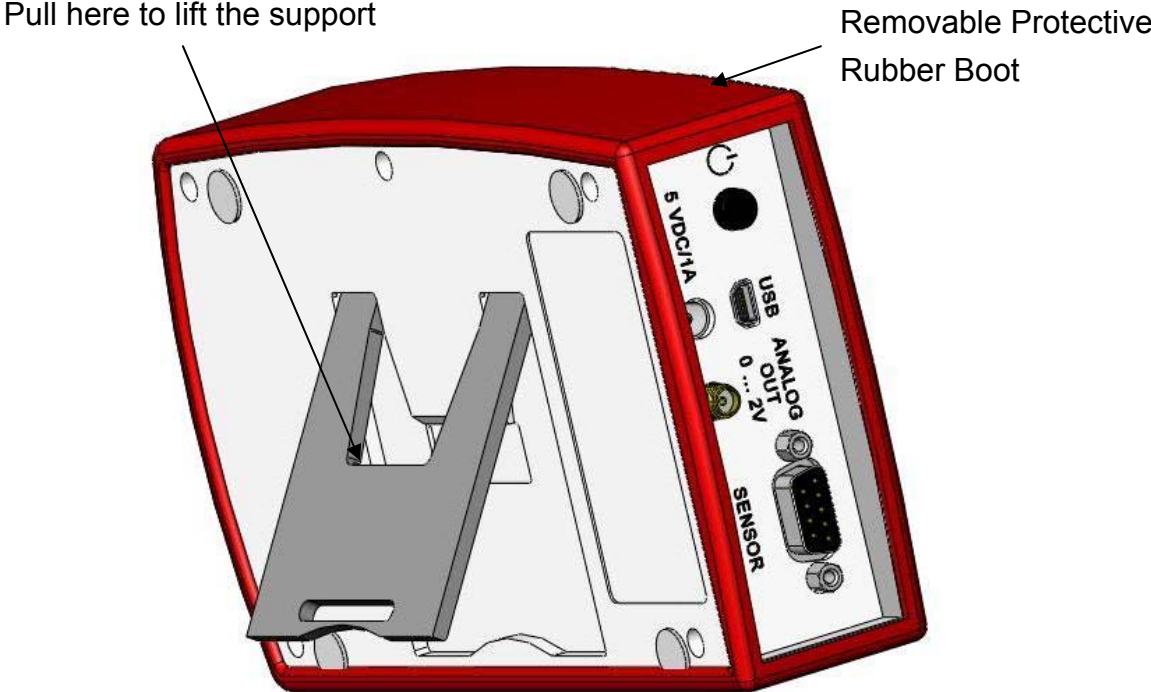

Figure 3 Rear View

3.2.4 Bottom

Mounting Thread 1/4"-20

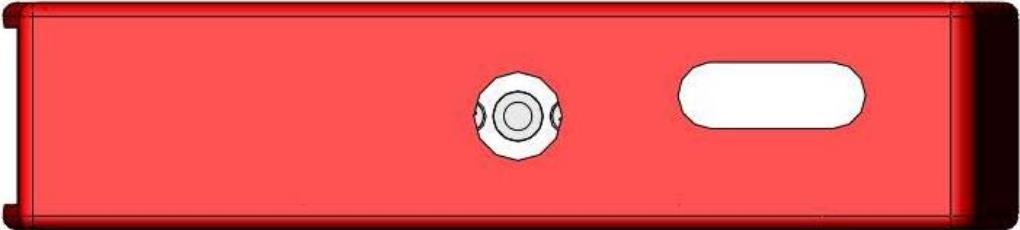

Figure 4 Physical Overview Bottom View

3.2.5 Display

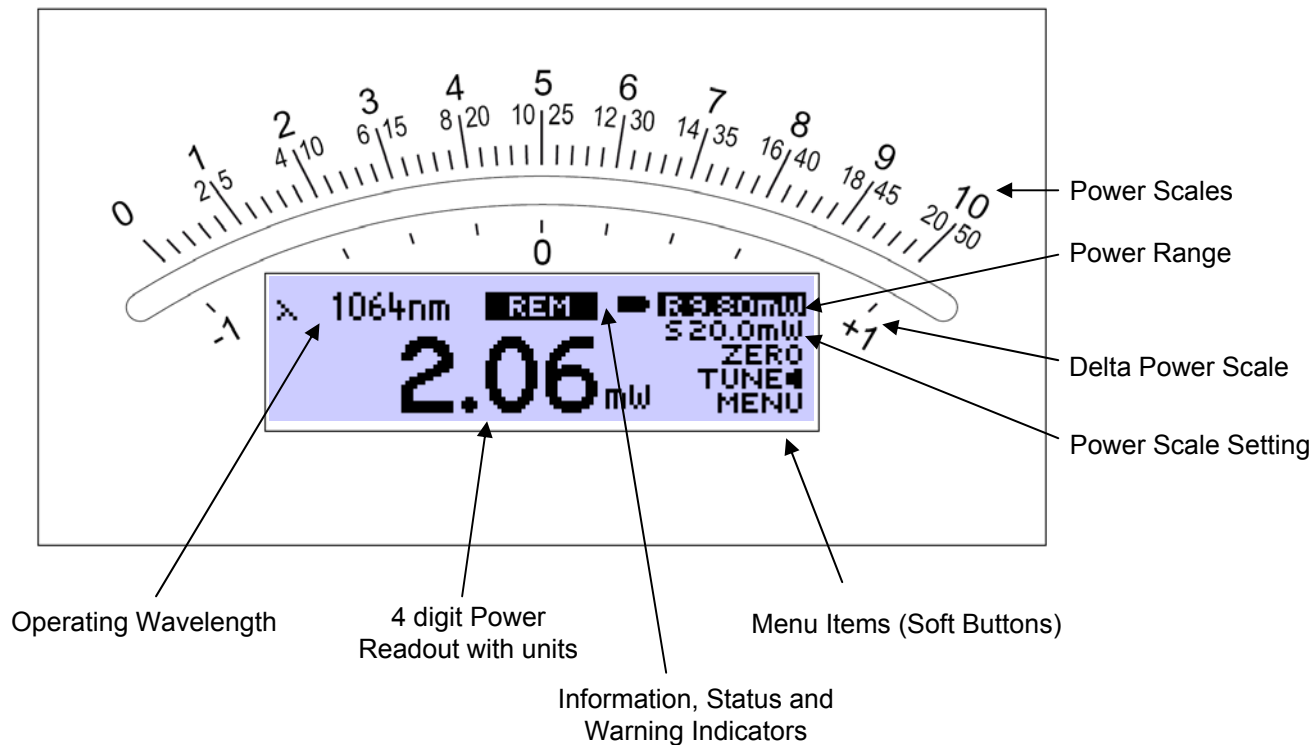

Figure 5 Display Setup

Operation Overview Standard Display:

Function Menu Item \ Key	OK	◀	▶	▲ ▼
R _ _ _ W	Auto set Meas. Range	Range Down	Range Up	Browse Menu Items
S _ _ _ W	Auto set Needle Scale	Zoom In Scale	Zoom Out Scale	
ZERO	Perform Zeroing	(No Function)		
TUNE ◀	Toggle Tune Sound	Reset Maximum Power Value		
MENU	Enter/Exit System Menu	Switch to Statistics View		

Operation Overview Statistics View:

Function Menu Item \ Key	OK	◀	▶	▲ ▼
R _ _ _ W	Auto set Meas. Range	Range Down	Range Up	Browse Menu Items
S _ _ _ W	Auto set Needle Scale	Zoom In Scale	Zoom Out Scale	
HOLD / RUN	Hold / Run Statistics	Reset Statistics Values		
TUNE ◀	Toggle Tune Sound	Reset Statistics Values		
MENU	Enter/Exit System Menu	Switch to Standard View		

4 Operating the PM100A

4.1 Connecting a Power Sensor

The PM100A supports all Thorlabs 'C-Series' photodiode and thermal sensors. These can easily be identified against older versions of Thorlabs power sensors by their red connector housing. The console will not recognize sensors from the 'A' and 'B' series. Please contact Thorlabs for the upgrade of old sensors with 'C-Series' connectors.

To plug or remove a sensor slightly press on the two bolts in the connector housing, that fix it by resilience. Sensors can be 'hot-swapped' to the console, after recognizing a new valid sensor the type and calibration data will be downloaded to the console in approximately 2 seconds, and the unit is ready to operate with the new sensor.

The PM100A also supports custom detectors, please refer to chapter 4.2.2 for the console measurement settings and chapter 7.4 for the connector pin-out.

4.2 Controlling the PM100A

4.2.1 Navigating the Menus

The measurement screens contain five menu items (soft buttons) that are arranged in a column in the right of the graphics display. These can be navigated with the up and down (▲▼) keys and controlled by the left and right (◀▶) keys and/or the enter/edit (OK) key.

The focus is always on the button in **inverse presentation**.

4.2.2 System Settings

After navigating to the bottom soft button **MENU** and confirming it with the **OK** key the system menu can be scrolled with the ▲ or ▼ keys. To perform the initial adjustments the settings can be edited or changed with the ◀ or ▶ keys on ring controls or by using all navigation keys for numeric controls.

The menu is arranged on three pages with four lines each. The items depend on the connected sensor. To leave the system menu press the **OK** key or navigate down or up to the 'EXIT' item and confirm with **OK**.

Page 1: Measurement Settings

- **Bandwidth** Sets input bandwidth to High or Low (◀▶)
(only visible with connected photodiode sensor)
- **Accelerator** Enables/disables the speed up circuit (◀▶)
(only visible with connected thermal sensors)
- **Attenuation** Includes a filter or beam splitter for the power calculation.
The input is in dB. When an attenuation is set, the value is displayed in the status indicator. (◀▶▲▼)
- **Line Filter** Sets the unit to the local line frequency 50Hz/60Hz
to avoid aliasing effects (◀▶)
- **Adapter Type** Sets the PM100A into the mode to measure photo current
or thermal voltage. Please refer to the chapters 4.2.5.1.2,
4.2.5.2.2 and 7.4 for connecting custom sensors. (◀▶)

Page 2: Console Settings

- **Interface** Shows the remote status. Press ◀ or ▶ to set the unit
back to local mode.
- **Backlight** Sets the brightness of the LCD and key backlight.
The setting range is 0 (off) – 100% (maximum). (◀▶▲▼)
- **Battery Timer** The unit automatically powers off in battery operation after
a certain time without user action. This feature can be set
to 10 or 60 minutes, or switched off; and is not active
when an external power supply (AC adapter or USB) is
connected. (◀▶)
- **Firmware Upload** Needs to be set to 'ON' before uploading a new firmware
version. The function will automatically reset to 'OFF' after
powering down. (◀▶)

Page 3: System Information

- **Console Information▶** Shows device type, serial number and calibration date.
(◀▶)
- **Sensor Information▶** Shows type and serial number of the connected
power sensor. (◀▶)
- **Tau** Sets the time constant for custom thermal sensors. (only
visible with connected custom thermal sensor) (◀▶▲▼)
- **EXIT** Aborts the system menu and switches back to the last
measurement screen. (OK)

4.2.3 Power Measurement

4.2.3.1 Range and Scale Control

4.2.3.1.1 Measurement Range Control

Navigate to the topmost menu item **R** **-.-- -W**; 6 power corresponding current or 4 power corresponding voltage ranges can be adjusted manually with the ◀ or ▶ keys. Pressing the **OK** key the unit performs a nonrecurring auto-ranging until the optimum range has been found for the currently measured power level. The range control menu item indicates the particular full range value in Watts.

A permanent auto-range mode is only available in remote operation.

4.2.3.1.2 Needle Scale Control

After setting the measurement range the unit automatically selects the needle scale, where the full power range is covered. To change the needle scale navigate to the **S** **-.-- -W** menu item. With the ◀ or ▶ keys the scale can be optimized to different end scales for best readability of the power value (zoom function). This adjustment can also be automated by pressing the **OK** key. The scale control menu item indicates the particular full scale value in Watts.

The scales end have a fixed 1 – 2 – 5 grid, therefore it is possible that the full scale range may be higher than the power range. In such a case, when the power level is exceeding the power range, the needle will deflect to the right stop and the readout value will indicate 'HIGH'.

4.2.3.2 Wavelength Correction



Most power and energy sensors show a dependent behaviour in their spectral response. For accurate measurements it is important to set the PM100A to the wavelength of the light to measure.

Pressing the **λ** key leads to a wavelength menu with 8+1 individually configurable sensor independent settings. The currently set operating wavelength is indicated by a following arrow (◀) and has focus when entering the menu. Select the desired operating wavelength by navigating with the ▲▼◀▶ keys and confirming with **OK**. The **λ** key allows to exit without changing the operating wavelength.

To preconfigure or edit a wavelength item, navigate to it and keep the **OK** key pressed until the last digit gets underlined. Set the desired wavelength with the **▲▼◀▶** keys and confirm with **OK**.

When selecting a wavelength that is not applicable for the connected sensor a warning sound will appear and the unit will keep the previous wavelength setting.

Wavelength setting in remote operation will overwrite the down to the right value.



Figure 6 Wavelength Correction

4.2.3.3 Zeroing

Confirming the **ZERO** menu item with **OK**, the unit performs an automated zero adjustment and from now on takes into account this zero level for the power readout calculation. This feature is used to zeroing thermal sensors, performing dark current adjustment on photodiode sensors or suppressing small ambient light levels. When the initial power level is too high, a failure message will appear that is prompting to cover the power sensor prior to zero adjustment.

Indicator that sensor needs to be zeroed

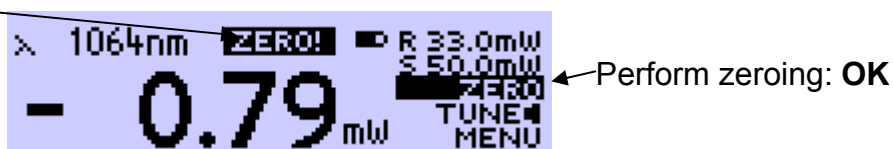

Figure 7 Zeroing

Do not hold a sensor in the hand, especially a thermal sensor, when performing a zero adjustment. Temperature effects will influence the quality of the zeroing result!

When measuring very small power levels dark current of photodiode sensors or zero voltage on thermal sensors will have an influence on the measurement result and must be compensated by the zero adjustment. An indicator that a sensor needs to be zeroed is when with covered sensor either a negative power reading or a reading much greater than zero is displayed. At negative power readings additionally a 'ZERO!' warning appears in the status display.

After performing a zero adjustment, the detected zero value will be included in all power readings. The detected zero value may influence the wavelength corrected calculated full scale power range values in the lower power ranges.

Photodiode sensors emit small current levels, even when no photons hit the active area – the so called dark current, that is temperature dependent and in the region of some nA for silicon and InGaAs sensors and up to some μA for germanium sensors. Thermopile sensors need to be zeroed when thermal differences between active area (thermal disk) and the sensor heat sink appear when no light hits the active area or when the heat sink gets hot under light exposure. The zero value will be negative when the heat sink is hotter than the active area and positive, when the active area is hotter than the heat sink. When both heat sink and active area are at room temperature a zero voltage of some μV is normal.

4.2.3.4 Setting an Attenuation / Gain Factor

To set an attenuation or gain factor that will be taken into account when calculating the displayed power, enter the system menu and navigate to the Attenuation item.

MENU \ Attenuation

When confirming this item with the **OK** key an attenuation or gain factor from 60 dB to -60 dB can be entered by the **▲▼◀▶** keys. A positive value will set an attenuation factor. Confirm the setting with **OK** and quit the menu by **◀** or **▶**.

The attenuation set value in dB will be indicated in the status display above the measurement value.

This feature can be used to display the origin laser or probe power, with having a filter or beam splitter in the system; or to enlarge the measurement range of a power or energy sensor with a calibrated filter.

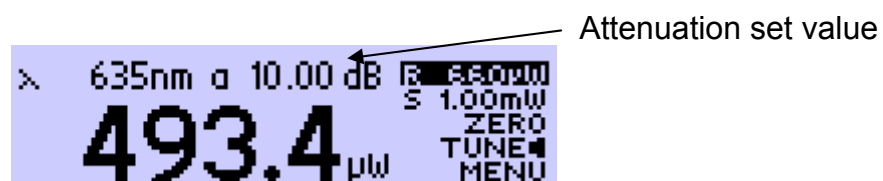

Figure 8 Attenuation

4.2.3.5 Relative Power Measurement Δ

The Δ key switches on and off the relative measurement mode. The main display will set to zero and gets signed, the offset and the absolute power value will be displayed in two sub displays in negative presentation. The analog needle will deflect to the middle position with bidirectional amplitude (0 at the scale below the mirror) and change to the next sensitive scale.

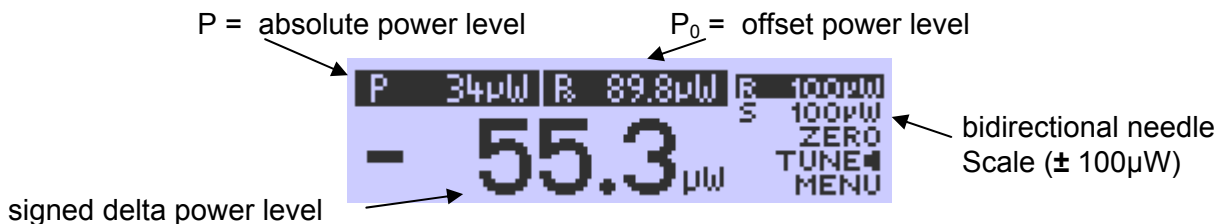

Figure 9 Relative Measurement

4.2.4 Display Options

The PM100A can toggle between the standard measurement screen and a statistics screen by navigating to the **MENU** item and pressing one of the ◀ or ▶ keys.

The statistics screen shows the actual, minimum, maximum and average power level. The **HOLD/RUN** soft button in the display menu controls this feature. When the item has focus, the **OK** button toggles between run and hold mode; in hold mode, the device samples in the background.

The ◀ or ▶ key resets all items to the actual power level and restarts sampling. Ranging during the sampling is possible, though once the actual level exceeds the measurement range, the stored and calculated values will show 'High'.

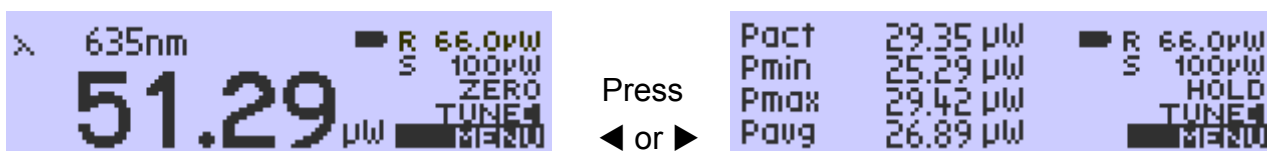

Figure 10 Display Options

4.2.5 Sensor Dependent Functions

4.2.5.1 Photodiode Sensors

The PM100A works with all Thorlabs S100C series photodiode power sensors. The sensor is ready to operate few seconds after plugging to the DB9 connector.

Attention

Refer to the sensor data sheet and pay attention to the optical damage threshold!

Exceeding these values will permanently destroy the sensor!

For the measurement of power levels from nano-watts up to 20 W Thorlabs offers photodiode sensors that show big advantages in sensitivity, stability and drift against thermal sensors. The sensors are built up in a combination of a photodiode and a neutral density filter or a photodiode in combination with an integrating sphere. They provide linearity over several decades and show a very good sensitivity at smallest power levels down to the pW range. Handling fairly small power levels the sensor size can be held small, further the response time of such sensors is very fast down to the sub-microsecond range.

Photodiodes, neutral density filters and also integrating sphere materials show a wavelength dependent behaviour and therefore each sensor is individually calibrated over the whole spectral working range in 5 or 10nm steps. Thereby the sensors spectral response data gets stored in a non-volatile memory inside the DB-9 sensor connector and downloaded to the PM100A when plugged to the unit. To perform an accurate measurement it is necessary to enter the operating wavelength of the light to measure so that the PM100A can calculate the laser power from the measured photo current and the right response value from the wavelength calibration table.

4.2.5.1.1 Bandwidth Setting (Signal Filtering)

The analogue bandwidth setting influences the power reading and the analogue output.

The bandwidth can be selected in the system menu under **MENU** \ Bandwidth.

Confirming the menu item with **OK**, the bandwidth setting will toggle between 'High' (range dependent bandwidth up to 100kHz) or 'Low' (15 Hz bandwidth).

For measuring CW or average power from pulsed sources the bandwidth should be set to 'Low'. When using the analogue output to control external equipment or

measuring peak power levels the 'High' setting is required so that the meter can follow the signal.

4.2.5.1.2 Power Measurements with Photodiodes

Common photodiodes can be used for power measurements with the PM100A. Therefore the PM100A needs to be set to the 'Photodiode' default setting in the system menu.

MENU \ Adapter Type \ Photo

To perform measurements, a photodiode and an interlock must be connected to the sensor input (see chapter 7.4 for the connector pin out); it is important to attend to the right polarity (the cathode needs to be connected to ground).

The operation is similar to photodiode power sensors with the exceptions that the response value in A/W is indicated instead of the operation wavelength and when pressing the λ key the response value (for one wavelength) can be set.



Figure 11 Photodiode Mode

4.2.5.2 Thermal Power Sensors

The PM100A is compatible to the Thorlabs S300C series thermal power sensors. The sensor will be ready to operate few seconds after plugging to the DB9 connector.

👉 Attention 👈

Refer to the sensor data sheet and pay attention to the optical damage threshold!

Exceeding these values will permanently destroy the sensor!

Thermal sensors absorb the incident laser power, whereby the developing heat gets turned into a small voltage caused by heat flow through thermocouple elements between absorbing area and sensor heat sink. Thorlabs offers with its S3xxC series thermal sensors that cover a wide range of applications. The sensors are available with different coatings. Black broad band coating as absorber does not need a

wavelength correction because the response is nearly flat from the UV to the mid-IR. Special hard coatings can withstand high power levels and show also a good spectral flatness. Further Thorlabs offers special heads for Excimer lasers with large beam diameters and short pulse lasers with coatings for very high peak power levels.

The output voltage of a thermal sensor is linear to the incident laser power, as long the thermal system is properly zeroed. The main application area for thermal sensors is the measurement of high power levels from 100mW. Thorlabs offers also a special thermally isolated thermal head with flat response and on power levels starting in the μ W range.

4.2.5.2.1 Readout acceleration

Thermal sensors show a fairly slow response. When laser power hits the active area it takes, depending on the sensor type, from some 1 up to 20 seconds until the system has settled and the power reading shows the right value.

Through special circuitry this time can be shortened to approximately 1-3 seconds by 'predicting' the final power value. The PM100A automatically uses the right adjustment of the electronics to the time constant of the thermal sensor. Nevertheless this circuitry has the disadvantage of inducing some noise to the measurement value. Therefore the acceleration circuit can be disabled / enabled in the system Menu: **MENU** \ Accelerator On/Off

4.2.5.2.2 Custom Thermal Elements

Custom thermal elements can be used for power measurements with the PM100A. Therefore the PM100A needs to be set to the 'Thermopile' default setting in the system menu:

MENU \ Adapter Type \ Thermo

To perform measurements, a thermal element and an interlock must be connected to the sensor input (see chapter 7.4 for the connector pin out). The operation is similar to thermal power sensors with following exceptions:

- The response value in V/W is indicated instead of the operation wavelength.
- When pressing the λ key the response value (for one wavelength) can be set.
- In system menu on page 3, the time constant ($\tau_0 - 63\%$) of the connected thermal sensor can be set. This time constant value adjusts the acceleration circuit for the measurement prediction.

4.3 Analog Output

The analog output provides on its SMA connector the amplified and buffered photodiode current or thermal sensor voltage.

For photodiode sensors the bandwidth setting influences the output signal; with thermal sensors the analog output shows the direct amplified and accelerated voltage response from the sensor.

The signals from the analog output are not wavelength and zero corrected!

The analog output voltage is range dependent and can be calculated to:

$$U_{\text{Analog Out}} = 2V / \text{power range value} \times \text{displayed power value}$$

The analog output voltage can range from -0.3V to +2.3V.

4.4 Tune Sound

The **TUNE** menu item switches on and off an audible tone for laser tuning support. The intermitting tone will increase its repetition rate up to a permanent sound at the maximum reached power level. When the Tune feature is activated, the maximum level is indicated instead of the operating wavelength. To reset the maximum power level to the actual level press one of the **◀** or **▶** keys.

Leaving the focus of the 'TUNE' item or pressing **OK** will stop the sound.

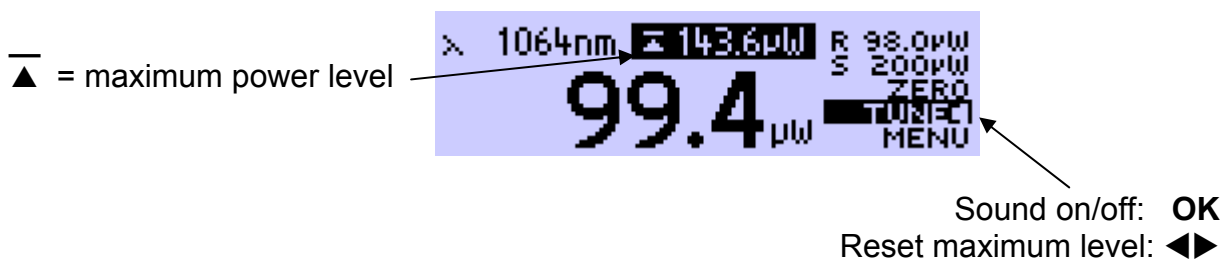

Figure 12 Tune Sound

4.5 Battery Charging

The PM100D is powered by a 1 cell LiPo⁺ battery that needs to be recharged intermittently by plugging the AC adapter or plugging the USB cable to a computer. To fully charge the battery it takes approximately 3-4 hours. A built in charging circuit automatically regulates and terminates the charging.

Following battery icons in the display header show the charging state from empty to full battery



The empty battery symbol starts blinking for one minute until the unit shuts off.

When an external power supply is plugged the symbols above change sequent until the battery is fully charged.

The following icon will appear when a wrong charger is connected or the battery gets not fully loaded after a given time of approximately four hours. This can happen when the unit is switched on, the charging is done via USB link and the computer cannot supply sufficient charging current. The symbol will disappear after 10 seconds when disconnecting the external power supply and show the actual battery charging state.



Should the 'arrow icon' permanently remain there may be a malfunction either in the battery itself or in the charging circuitry, please refer to chapter 6.3 for maintenance and repair.

The AC adapter for charging the system battery that comes with the PM100A provides a wide range power input from 100VAC to 240VAC and an output voltage from 5VDC. The mains connectors for US, Europe, UK and Australia can be switched by pressing the lever and pulling off; the new connector easily clicks into the socket.

Do not use other than the provided power supply at the DC input. Higher input voltages may damage the unit.

When charging the battery via USB link it will take longer until the battery is fully charged or it never gets completely fully charged. It depends on the connected computer what charging current can be supplied. The maximum current that can be drained via USB is limited to 500mA. Some laptop computers just can drive 100mA via USB interface.

5 Measurement Considerations

5.1 Choosing the right Sensor

The question of the right sensor depends on many factors starting with the light source to measure and the application. No sensor can cover all applications; the following table shows the main pros and contras of the different power sensor types. Of course this can only be a rough guide because within each sensor group there are special models best suitable for specific applications.

Power Sensors:

Light Source	Photodiode			Thermal		
	Si	Ge	InGaAs	BB	HTC	Volume
Diode UV - NIR	+++	+	-	++	-	-
Diode NIR	-	+	+++	++	-	-
High Power Fiber Lasers	-	-	++	++	++	-
ASE sources	-	-	++	++	-	-
fs Laser	-	+	++	++	+	-
Gas Laser	++	-	-	++	+	-
Excimer	-	-	-	-	+++	+
YAG	-	-	-	-	+	+++
LED	+	-	-	+++	+	-

5.2 Reducing Noise for High Accuracy Measurements

Main disturbing influence on each measurement is noise from grounding, the cable capacitance, temperature effects, stray and ambient light and detector noise.

- The housing of power sensors are connected to the digital ground of the meter and should be linked to earth ground (e.g. via a post); energy sensors should be mounted isolated, because the housing is connected to the meter analog ground.
- The sensor cable must handle very small current or voltage signals. Moving the cable will induce disturbances given through the cable capacitance. For measuring small power or energy levels the cable should be fixed in position.
- With photodiode sensors the bandwidth should be set to “Low” setting; with thermal sensors the acceleration circuit should be shut off.

- The detector noise is lowest with silicon or InGaAs sensors.
- For long term measurements in free space applications it is necessary to provide constant ambient light conditions, or shielding the beam.
- The temperature should be stable over the time of the measurement.

5.3 Power Measurement of Pulsed Signals

The PM100A will read the average value of a pulsed signal when the following conditions apply: For a thermal sensor pulse length, repetition rate and peak power is uncritical as long as the peak power is lower than the damage threshold of the sensor. A thermal sensor reacts very slow and will integrate the power incident on the active area of the sensor.

With a photodiode sensor that can follow short pulses in the ns range it is important that the pulse peak power is within the maximum power range of the sensor. It is also important that the power range is set that accordingly the peak power is within this range, otherwise the reading will clip at the range end and lead to a wrong average value. Further it is important to use a power range that can measure the peak value, therefore the Min-Max function is very helpful. Depending on the pulse length and repetition rate the bandwidth setting will influence the power reading. It is recommended to use the 'LOW' bandwidth setting for a stable display; when the pulse should be monitored via the analog output, the bandwidth should be set to 'HIGH'.

5.4 Line width of Light Sources

The line width of light sources can be neglected only when using a broadband thermal or pyro-electric sensor. Photodiode sensors show a strong dependency of the operating wavelength so if the line width of light sources is greater than 10nm (e.g. LED) there may be an influence on the displayed power. To achieve the best result for broadband light sources with a photodiode sensor it is necessary that the response curve is nearly linear over the line width. When entering the center wavelength of the light source as operation wavelength the PM100A will nearly show the right optical power for a symmetrical spectral response shape.

5.5 Temperature Effects on Thermal Sensors

Thermal sensors react on any temperature differences that occur between thermal disc and heat sink. Influence to the measurement result can be caused by airflow

disturbances or by heating up the heat sink through long enough exposure of the laser beam to the thermal disc.

To avoid disturbances it is recommended to shield the sensor as good as possible from airflow and to zero it properly in the operating condition. That means for short term measurements zero the cold sensor, for long term measurements zero the sensor when it is in a state of thermal stability (e.g. after 10 minutes light exposure).

5.6 Ambient and Stray Light

Ambient or stray light can strongly affect the measurement accuracy in free-space applications. A permanent background light level can be subtracted by conducting a zero adjustment. More complicated is varying ambient light like daylight or turning on/off room light. In such cases the only solution is a proper light shielding of the sensor.

5.7 Back Reflection

Photodiodes, ND filters and even black coatings of thermal sensors show a certain kind of back reflection of the incoming light. Back reflection for example to a diode or HeNe laser can distort the power stability of the laser, therefore it is recommended to slightly tilt the power meter sensor in the laser beam.

When back reflection must be avoided it is advised to use an integrating sphere based S14xC series sensor where the incoming light gets nearly completely absorbed in the sensor.

5.8 Beam Diameter vs. Active Sensor Area

Most sensors are not completely uniform in their response over the active area; except are sensors that are using an integrating sphere as filter and diffuser.

To overcome uniformity issues the incident beam should have a diameter larger than 10% sensor area.

A second topic to follow are the maximum allowed power and energy densities of the sensor. The maximum ratings are given in the sensor spec-sheet. The PM100A can display the actual power or energy density for a known beam diameter. For high power or high energy beams a good efficiency can be reached to chose a detector that is about 20% - 30% larger than the beam diameter.

5.9 Fiber Based Measurements

Laser light emits from an optical fiber in a conical shape, with an angle twice the acceptance angle of the fiber. The acceptance angle is calculated by the numerical aperture of the fiber and is defined as the inverse sine of the numerical aperture.

For typical single mode fibers the total angle of the emitted light is between 15° and 25°, for an angled connector (APC) the cone shifts by approximately 4° from the fiber axis.

This expansion of the beam has to be considered to avoid overfilling the detector and getting wrong results. On the other hand for measurements with high power fiber lasers a certain gap between fiber tip and detector surface has to be kept to decrease the power density.

Thorlabs offers fiber adapters with the most common connectors that are verified with the S12xC series optical sensors and with most thermal sensors.

For large divergence angles or fiber measurements that are critical to back-reflections it is recommended to use an integrating sphere based sensor from the S14xC series.

Another good choice for fiber based measurements are the new 'Fiber-Heads' of the S15xC series. They plug directly to the meter and go without a disturbing cable between sensor and console.

6 Computer Interface

The PM100A optical power meter has a USB 2.0 interface that allows to send commands from a host computer to the instrument. The connection between PC and PM100A is accomplished by a USB cable with a male type 'A' connector at the PC side and a type 'Mini B' connector on the instrument side.

When connecting the PM100A to the PC first time, a new hardware will be found. For proper installing the PM100A it requires a NI-VISA runtime version on the PC (available on the National Instruments website www.ni.com or from the data carrier that comes with the instrument. Allow installing and follow the dialog instructions.

6.1 PM100 Utility Software

The PM100A comes with a utility software that easily enables remotely operating the PM100A and visualizing and logging measurement data. The software is written in LabVIEW 8.5.1 and can either be installed from the data carrier as executable where LabVIEW isn't required on the PC; or can be run with LabVIEW 8.5.1 or higher.

The source code of the application is included on the data carrier and can be used to build own applications or to modify the utility program to specific requirements.

After launching the PM100 utility program it will automatically screen for connected PM100A, PM100D or PM100USB devices. Select the desired device and press o.k. In case that the connected PM100A is not yet recognized, press Rescan to perform a new search for connected PM100A devices.

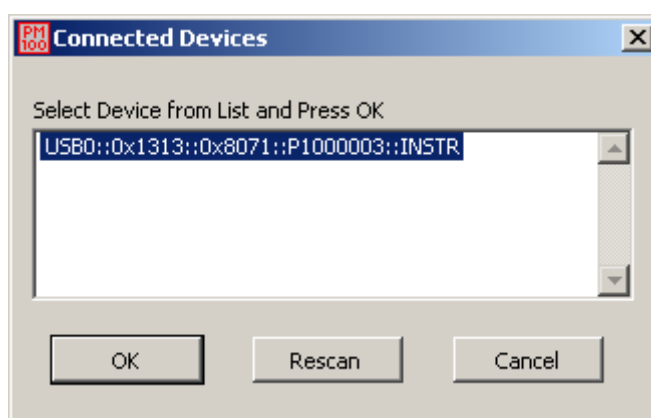

The identification string contains the following items:

- USB Port number
- Thorlabs Vendor ID = 0x1313
- Product ID = 0x8071 = PM100A
- Instrument serial number
- Measurement instrument device

6.1.1 Front Panel

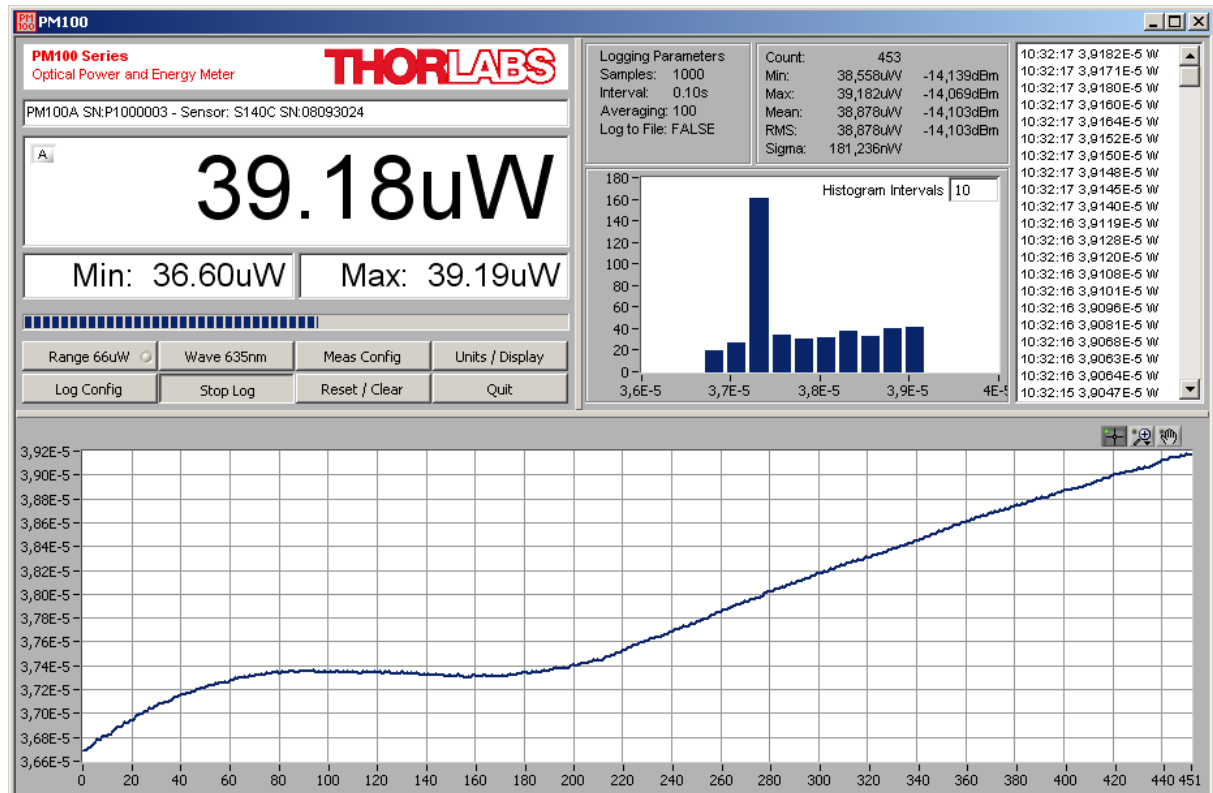

6.1.2 Description of the Front Panel Elements:

Header

This indicator shows the device setup:

- console type (PM100A, PM100D or PM100USB)
- serial number of the console
- sensor type
- sensor serial number

Main Display

The display has a configurable display resolution. Independent from the measurement range the display always has the full number of the selected digits.

To achieve best AD converter resolution it is necessary to set the measurement range according to the signal to measure.

A trigger indicator shows whether the unit is sampling data 'A' indicator or a new measurement value gets displayed 'T' indicator and green light.

Left Sub Display

The display has the following configurable items:

- no display
 - maximum value - sampling until reset
 - ratio max/min value - sampling until reset
 - power or energy density
 - alternate unit depending on connected sensor
- the possible choices depend on the connected sensor

Right Sub Display

The display has the following configurable items, the possible choices depend on the connected sensor::

- no display
- minimum value - sampling until reset
- frequency or repetition rate
- temperature
- resistance of temperature sensor

Bargraph indicator

The bargraph indicator shows the incidence or the used measurement range.

Statistics screen

Statistical values in linear and logarithmic representation

Data logging screen

Shows the logging history data

Histogram Power / Energy histogram

- displays histogram data

Chart display

Power/Energy Chart with Y auto scale and a 1000 point history length

Range button

Press to open a dialog box for setting the measurement range

The indicator in the button shows the currently used measurement range in the chosen unit. A green light indicates 'auto-ranging'

Shortcut: [Shift + F1]

Wavelength / Response button

Press this button to open a dialog box for setting the correction wavelength, or in adapter mode to enter the responsivity value in A/W or V/W.

The currently used parameter is indicated in the button label.

Shortcut: [Shift + F2]

Measurement configuration button

Depending on the connected sensor the following parameters can be set in the dialog box:

- display resolution - set number of digits
- averaging rate, a rate of 3000 averages the incoming measurement values for approx. 1 second
- photodiode bandwidth HI and LO
- acceleration circuit for thermal sensors ON and OFF
- trigger level for pyroelectric sensors
- Zeroing for photodiode and thermal sensors

Shortcut: [Shift + F3]

Units / Display button

A dialog box with the following items appears:

- configure unit of measure, depending on the connected sensor in W, J, dBm, V and A
 - configure the left sub display
 - configure the right sub display
- Shortcut: [Shift + F4]

Logging configuration button

Open dialog box to:

- set averaging rate for logging
- set interval between samples
- set number of samples
- configure logging into data file

Shortcut: Shift + F5

Start/Stop log button

- start and stop data logging

Shortcut: [Shift + F6]

Reset / Clear button

- reset min/max monitor
- clear power / energy graph
- clear power / energy histogram
- clear power / energy statistics
- clear log screen

Shortcut: [Shift + F7]

Quit button

- stops the PM100 application
- to restart press the white arrow in the tool bar

Shortcut: [Shift + F8]

6.2 Firmware Update

Firmware upgrades can be done by the user via the USB interface. Therefore install the DFU (device firmware upgrade) wizard from the distribution data carrier.

Switch on the PM100A and enable the firmware download in the system menu:

MENU \ FW Update \ ON

(This setting will be reset to 'OFF' after the unit was shut off.)

Connect the PM100A to an USB port of your PC, the PC will find a DFU device; when proceeding the DFU wizard the first time a new DFU device will be recognized, please allow installing.

After then launch the DFU wizard from the start bar. Follow the wizard instructions.



Please refer to www.thorlabs.com for the latest PM100A firmware version that can be downloaded as a *.dfu file.

Do not switch off the PM100A or disconnect the USB cable while the firmware is downloading!

6.3 Simple LabVIEW Example using SCPI Commands

This example works with PM100D, PM100A and PM100USB



PM100D Simple Example.vi

This VI shows how to communicate with a PM100A optical power meter or PM100D optical power/energy meter with SCPI commands. The following steps are demonstrated within this application:

- Initializing the instrument
- Getting system info
- Setting parameters
- Measurement configuration
- Measuring queue
- Fetching and displaying a measurement value
- Closing the application

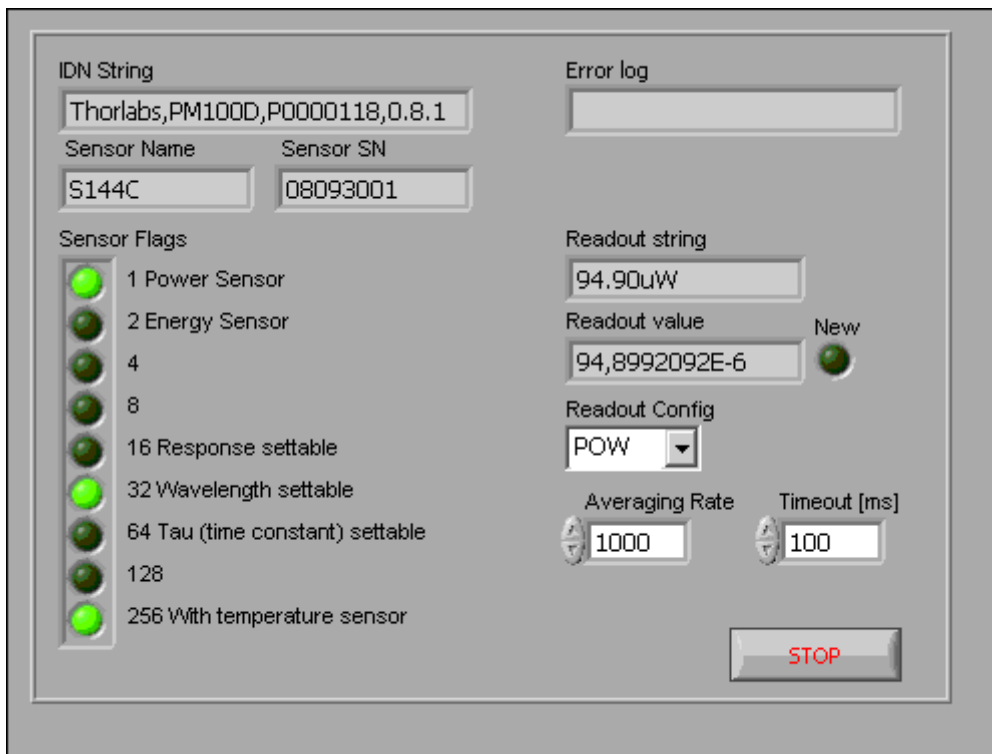

Averaging Rate

Sets the averaging rate - 3000 averages take approximately 1s for performing a new measurement value

Readout Config

Selects the measurement parameter

- POW power measurement in W
- CURR current measurement in A
- VOLT voltage measurement in V
- ENER energy measurement in J (PM100D / PM100USB only)
- FREQ frequency / repetition rate measurement in Hz (PM100D/USB)
- PDEN power density measurement in W/cm² (PM100D/USB only)
- EDEN energy density measurement in J/cm² (PM100D/USB only)

- RES thermistor resistance measurement in Ohm
- TEMP temperature measurement in °C



Stop

Stops application



Timeout [ms]

Sets a timeout value in ms that allows the instrument to sample. The timeout must be longer than it takes to perform a new measurement. This has especially to be considered when performing single shot energy measurements.



Error log

Error indicator, 'no error' is suppressed



Readout string

Formatted measurement value

- limitation to 4 significant digits
- SI notation
- '.' decimal separator
- appended unit according readout configuration



New

Indicator lights up, when a new measurement value is processed



Sensor Flags



Sensor flag bitmap:

- 1 Is power sensor
- 2 Is energy sensor
- 16 Response settable
- 32 Wavelength settable
- 64 Tau settable
- 256 Has temperature sensor



Sensor Name

Name of connected power/energy sensor



Sensor SN

Serial number of connected power/energy sensor



IDN String

Answer from instrument on *idn? command:

- manufacturer
- model number
- serial number
- firmware version



Readout value

Plain readout value in full resolution

Block diagram

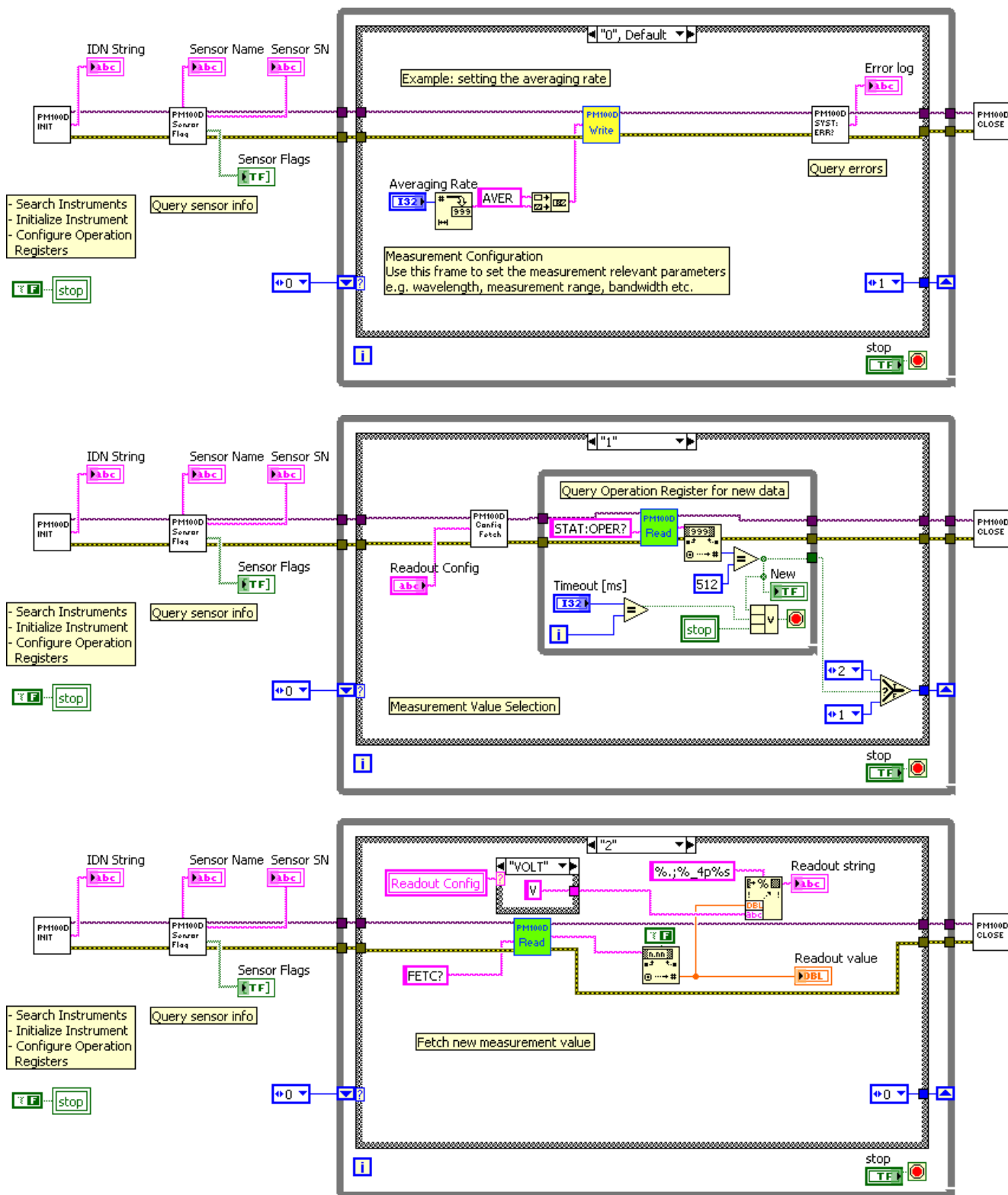



PM100D_Initialize.vi

This VI scans for connected devices, that can be selected in a dialog box.

Next steps

- setting timeout
- performing identification query
- configuring the operation register to '512'; flag gets to HI when a new measurement value is ready to fetch
- clear operation register



PM100D_Write.vi

Writes a SCPI command to the connected instrument



PM100D_Read.vi

Reads data from the connected instrument. All query commands according the SCPI command table are terminated by a question mark (?)



PM100D_SensorFlag.vi

This VI queries all relevant sensor info with SYST:SENS:IDN?

- sensor name
- sensor serial number
- calibration message
- sensor type
- sensor sub-type
- sensor flags



PM100D_ConfMeas.vi

- CONFIGure measurement; CONF:<parameter> (POW, ENER, etc.)
- ABORT measurement
- Clear operation register with STAT:OPER?
- INITiate measurement



PM100D_SYST-ERR.vi

This VI lists all errors coming from the instrument with the command SYST:ERR?

'no error' is suppressed



PM100D_Close.vi

Closes the VISA session

Sets the connected instrument in local mode (default option)

6.4 Using the Instrument Drivers

The PM100USB software package contains a set of instrument drivers that allow conveniently remote controlling the instrument in most common programming languages. The instrument drivers must be installed, please follow the setup dialog instructions.

To successfully complete the install of the PM100 USB drivers you must have Administrator privileges on the PC which you are performing the install.

Prior to connecting the PM100A with the PC, please insert the data carrier that shipped with the instrument and install the PM100 drivers. When the following message appears after the installation you have also to install NI-VISA from the distribution CD or from the National Instruments web site



After successfully installing the software connect the PM100A to a USB port of your PC. The PC will find a PM100A test and measurement device. Please follow the instructions of the dialog screens and allow the installing.

6.5 SCPI Commands

6.5.1 An Introduction to the SCPI language

SCPI (*Standard Commands for Programmable Instruments*) is an ASCII-based instrument command language designed for test and measurement instruments.

SCPI commands are based on a hierarchical structure, also known as a *tree system*. In this system, associated commands are grouped together under a common node or root, thus forming *subsystems*. A portion of the `SENSE` subsystem is shown below to illustrate the tree system.

```
[SENSe:]
CORRection
  :COLLect
  :ZERO
  [:INITiate]
  :ABORT
  :STATe?
  :MAGNitude?
  :BEAMdiameter {MINimum|MAXimum|DEFault|<numeric_value> [mm] }
  :BEAMdiameter? [{MINimum|MAXimum|DEFault}]
  :WAVelength {MINimum|MAXimum|<numeric_value> [nm] }
  :WAVelength? [{MINimum|MAXimum}]
  :POWer
    [:PDIode]
      [:RESPonse] MINimum|MAXimum|DEFault|<numeric_value> [A] }
      [:RESPonse]? [{MINimum|MAXimum|DEFault}]
    :THERmpile
      [:RESPonse] {MINimum|MAXimum|DEFault|<numeric_value> [V] }
      [:RESPonse]? [{MINimum|MAXimum|DEFault}]
```

`SENSe` is the root keyword of the command, `CORRection` is the second-level keyword, and `COLLect` and `BEAMdiameter` are third-level keywords, and so on.

A *colon* (`:`) separates a command keyword from a lower-level keyword.

Command Format

The format used to show commands in this manual is shown below:

```
CURRent[:DC]:RANGe {MINimum|MAXimum|<numeric_value> [A] }
CORRection:BEAMdiameter {MINi-
mum|MAXimum|DEFault|<numeric_value> [mm] }
```

The command syntax shows most commands (and some parameters) as a mixture of upper- and lower-case letters. The upper-case letters indicate the abbreviated spelling for the command. For shorter program lines, send the abbreviated form. For better program readability, send the long form.

For example, in the above syntax statement, `CURR` and `CURRENT` are both acceptable forms. You can use upper- or lower-case letters. Therefore, `CURRENT`, `current`, and `Current` are all acceptable. Other forms, such as `CUR` and `CURREN`, will generate an error.

Braces ({ }) enclose the parameter choices for a given command string. The braces are not sent with the command string. A *vertical bar* (|) separates multiple parameter choices for a given command string.

Triangle brackets (< >) indicate that you must specify a value for the enclosed parameter. For example, the above syntax statement shows the *range* parameter enclosed in triangle brackets. The brackets are not sent with the command string. You must specify a value for the parameter (such as "CURR:DC:RANG 50E-6").

Some parameters are enclosed in *square brackets* ([]). The brackets indicate that the parameter is optional and can be omitted. The brackets are not sent with the command string. In this example [:DC] can be omitted, so the command string can be shortened to "CURR:RANG 50E-6". If you do not specify a value for an optional parameter, the power/energy meter chooses a default value.

Command Separators

A *colon* (:) is used to separate a command keyword from a lower-level keyword. You must insert a *blank space* to separate a parameter from a command keyword. If a command requires more than one parameter, you must separate adjacent parameters using a *comma* as shown below:

```
"SYST:TIME 10, 34, 48"
```

A *semicolon* (;) is used to separate commands within the *same* subsystem, and can also minimize typing. For example, sending the following command string:

```
"CORR:BEAM 1; WAVE 1310"
```

... is the same as sending the following two commands:

```
"CORR:BEAM 1"
```

```
"CORR:WAVE 10"
```

Use a colon *and* a semicolon to link commands from *different* subsystems. For example, in the following command string, an error is generated if you do not use both the colon *and* semicolon:

```
"CORR:BEAM 1; :AVER 300"
```

Using the MIN and MAX Parameters

You can substitute MINimum or MAXimum in place of a parameter for many commands. For example, consider the following command:

```
CURRENT[:DC]:RANGE {MINimum|MAXimum|<numeric_value>[A]}
```

Instead of selecting a specific current range, you can substitute MIN to set the range to its minimum value or MAX to set the range to its maximum value.

Querying Parameter Settings

You can query the current value of most parameters by adding a *question mark* (?) to the command. For example, the following command sets the operating wavelength to 1550 nm: "CORR:WAVE 1550"

You can query the operating wavelength by executing: "CORR:WAVE?"

You can also query the minimum or maximum operating wavelength allowed as follows:

```
"CORR:WAVE? MIN"
```

```
"CORR:WAVE? MAX"
```

Caution If you send two query commands without reading the response from the first, and then attempt to read the second response, you may receive some data from

the first response followed by the complete second response. To avoid this, do not send a query command without reading the response. When you cannot avoid this situation, send a device clear before sending the second query command.

SCPI Command Terminators

A command string sent to the power/energy meter *must* terminate with a <new line> character. The IEEE-488 *EOI* (end-or-identify) message is interpreted as a <new line> character and can be used to terminate a command string in place of a <new line> character. A <carriage return>

followed by a <new line> is also accepted. Command string termination will *always* reset the current SCPI command path to the root level.

IEEE-488.2 Common Commands

The IEEE-488.2 standard defines a set of *common commands* that perform functions like reset, self-test, and status operations. Common commands always begin with an asterisk (*), are four to five characters in length, and may include one or more parameters. The command keyword is separated from the first parameter by a *blank space*. Use a *semicolon* (;) to separate multiple commands as shown below:

```
"*RST; *CLS; *ESE 32; *OPC?"
```

SCPI Parameter Types

The SCPI language defines several different data formats to be used in program messages and response messages.

Numeric Parameters Commands that require numeric parameters will accept all commonly used decimal representations of numbers including optional signs, decimal points, and scientific notation.

Special values for numeric parameters like `MINimum`, `MAXimum`, and `DEFault` are also accepted. You can also send engineering unit suffixes with numeric parameters (e.g., M, K, or u). If only specific numeric values are accepted, the power/energy meter will automatically round the input numeric parameters. The following command uses a numeric parameter:

```
POWER:REFERENCE {MINimum|MAXimum|DEFault|<numeric_value> [W]}
```

Discrete Parameters Discrete parameters are used to program settings that have a limited number of values (like W, DBM). They can have a short form and a long form just like command keywords. You can mix upper- and lower-case letters. Query responses will *always* return the short form in all upper-case letters. The following command uses discrete parameters:

```
POW:UNIT {W|DBM}
```

Boolean Parameters Boolean parameters represent a single binary condition that is either true or false. For a false condition, the power/energy meter will accept "OFF" or "0". For a true condition, the meter will accept "ON" or "1". When you query a boolean setting, the instrument will *always* return "0" or "1". The following command uses a boolean parameter:

```
CURRENT:RANGE:AUTO {OFF|0|ON|1}
```

String Parameters String parameters can contain virtually any set of ASCII characters. A string *must* begin and end with matching quotes; either with a single quote or with a double quote. You can include the quote delimiter as part of the string by typing it twice without any characters in between. The following command uses a string parameter:

```
DIAG:CALString <quoted string>
```

6.5.2 IEEE488.2 Common Commands

Common commands are device commands that are common to all devices according to the IEEE488.2 standard. These commands are designed and defined by this standard. Most of the commands are described in detail in this section. The following common commands associated with the status structure are covered in the “Status Structure” section: *CLS, *ESE, *ESE?, *ESR?, *SRE, *SRE?, *STB?

6.5.2.1 Command summary

Mnemonic	Name	Description
*CLS	Clear status	Clears all event registers and Error Queue
*ESE <NRf>	Event enable command	Program the Standard Event Enable Register
*ESE?	Event enable query	Read the Standard Event Enable Register
*ESR?	Event status register query	Read and clear the Standard Event Register
*IDN?	Identification query	Read the unit's identification string
*OPC	Operation complete command	Set the Operation Complete bit in the Standard Event Register
*OPC?	Operation complete query	Places a “1” into the output queue when all device operations have been completed
*RST	Reset command	Returns the unit to the *RST default condition
*SRE <NRf>	Service request enable command	Programs the Service Request Enable Register
*SRE?	Service request enable query	Reads the Service Request Enable Register
*STB?	Status byte query	Reads the Status Byte Register
*TST?	Self-test query	Performs the unit's self-test and returns the result.
*WAI	Wait-to-continue command	Wait until all previous commands are executed

6.5.2.2 Command reference

6.5.2.2.1 *IDN? – identification query - read identification code

The identification code includes the manufacturer, model code, serial number, and firmware revision levels and is sent in the following format:
THORLABS,MMM,SSS,X.X.X

Where: MMM is the model code
 SSS is the serial number
 X.X.X is the instrument firmware revision level

6.5.2.2.2 *OPC – operation complete - set OPC bit

6.5.2.2.3 *OPC? – operation complete query – places a “1” in output queue

When *OPC is sent, the OPC bit in the Standard Event Register will set after all pending command operations are complete. When *OPC? is sent, an ASCII “1” is placed in the Output Queue after all pending command operations are complete.

Typically, either one of these commands is sent after the INITiate command. The INITiate command is used to take the instrument out of idle in order to perform measurements. While operating within the trigger model layers, many sent commands will not execute. After all programmed operations are completed, the instrument returns to the idle state at which time all pending commands (including *OPC and/or *OPC?) are executed. After the last pending command is executed, the OPC bit and/or an ASCII “1” is placed in the Output Queue.

When *OPC is sent, the OPC bit in the Standard Event Register will set after all pending command operations are complete. When *OPC? is sent, an ASCII “1” is placed in the Output Queue after all pending command operations are complete.

6.5.2.2.4 *RST – reset – return instrument to defaults

When the *RST command is sent, the instrument performs the following operations:

- Returns the instrument to the default conditions
- Cancels all pending commands.
- Cancels response to any previously received *OPC and *OPC? commands.

6.5.2.2.5 *TST? – self-test query – run self test and read result

Use this query command to perform the instrument self-test routine. The command places the coded result in the Output Queue. A returned value of zero (0) indicates that the test passed, other values indicate that the test failed.

6.5.2.2.6 *WAI – wait-to-continue – wait until previous commands are completed

The *WAI command is a no operation command for the instrument and thus, does not need to be used. It is there for conformance to IEEE488.2.

6.5.2.3 PM100D specific SCPI Command Reference

See also SCPI Specification, Version 1999.0, May, 1999, <http://www.scpiconsortium.org> . All commands with a 'SCPI' checkmark are described in the SCPI specification.

6.5.2.3.1 SYSTem subsystem commands

Command	Description
SYSTem	Path to SYSTem subsystem. (SCPI Vol.2 §21)
:BEEPer	
[:IMMediate]	Issue an audible signal. (SCPI Vol.2 §21.2.2)
:STATe { <u>ON</u> 1 OFF 0}	Activate/deactivate the beeper. (SCPI Vol.2 §21.2.3)
:STATe?	Return the state of the the beeper (SCPI Vol.2 §21.2.3)
:ERRor	
[:NEXT]?	Returns the latest <error code, "message">. (SCPI Vol.2 §21.8.8)
:VERSion?	Query level of SCPI standard (1999.0) . (SCPI Vol.2 §21.21)
:DATE <year>,<month>,<day>	Sets the instrument's calendar. (SCPI Vol.2 §21.7)
:DATE?	Query the instrument's calendar. (SCPI Vol.2 §21.7)
:TIME <hour>,<min>,<sec>	Sets the instrument's clock. (SCPI Vol.2 §21.19)
:TIME?	Query the instrument's clock. (SCPI Vol.2 §21.19)
:LFRequency <numeric value>	Sets the instrument's line frequency setting to 50 or 60Hz. (SCPI Vol.2 §21.13)
:LFRequency?	Query the instrument's line frequency setting. (SCPI Vol.2 §21.13)

Commands for PM100D only

:SENSor															
:IDN?	<p>Query information about the connected sensor. This is a query only command. The response consists of the following fields: <name>, <sn>, <cal_msg>, <type>, <subtype>, <flags></p> <p><name>: Sensor name in string response format <sn>: Sensor serial number in string response format <cal_msg>: calibration message in string response format <type>: Sensor type in NR1 format <subtype>: Sensor subtype in NR1 format <flags>: Sensor flags as bitmap in NR1 format.</p> <table border="0" data-bbox="901 792 1369 1113"> <thead> <tr> <th style="text-align: left;"><u>Flag:</u></th> <th style="text-align: left;"><u>Dec.value:</u></th> </tr> </thead> <tbody> <tr> <td>Is power sensor</td> <td>1</td> </tr> <tr> <td>Is energy sensor</td> <td>2</td> </tr> <tr> <td>Response settable</td> <td>16</td> </tr> <tr> <td>Wavelength settable</td> <td>32</td> </tr> <tr> <td>Tau settable</td> <td>64</td> </tr> <tr> <td>Has temperature sensor</td> <td>256</td> </tr> </tbody> </table>	<u>Flag:</u>	<u>Dec.value:</u>	Is power sensor	1	Is energy sensor	2	Response settable	16	Wavelength settable	32	Tau settable	64	Has temperature sensor	256
<u>Flag:</u>	<u>Dec.value:</u>														
Is power sensor	1														
Is energy sensor	2														
Response settable	16														
Wavelength settable	32														
Tau settable	64														
Has temperature sensor	256														

6.5.2.3.2 STATus subsystem commands

Command	Description
STATus	Path to STATus subsystem. (SCPI Vol.2 §20)
:MEASurement	Path to control measurement event registers
[:EVENT]?	Read the event register
:CONDition?	Read the condition register
:PTRansition <value>	Program the positive transition filter
:PTRansition?	Read the positive transition filter
:NTRansition <value>	Program the negative transition filter
:NTRansition?	Read the negative transition filter
:ENABLE <value>	Program the enable register
:ENABLE?	Read the enable register
:AUXillary	Path to control measurement event registers
[:EVENT]?	Read the event register
:CONDition?	Read the condition register
:PTRansition <value>	Program the positive transition filter
:PTRansition?	Read the positive transition filter
:NTRansition <value>	Program the negative transition filter
:NTRansition?	Read the negative transition filter
:ENABLE <value>	Program the enable register
:ENABLE?	Read the enable register
:OPERation	Path to control operation event registers
[:EVENT]?	Read the event register
:CONDition?	Read the condition register
:PTRansition <value>	Program the positive transition filter
:PTRansition?	Read the positive transition filter
:NTRansition <value>	Program the negative transition filter
:NTRansition?	Read the negative transition filter
:ENABLE <value>	Program the enable register
:ENABLE?	Read the enable register

:QUESTionable	Path to control questionable event registers
[:EVENT]?	Read the event register
:CONDition?	Read the condition register
:PTRansition <value>	Program the positive transition filter
:PTRansition?	Read the positive transition filter
:NTRansition <value>	Program the negative transition filter
:NTRansition?	Read the negative transition filter
:ENABle <value>	Program the enable register
:ENABle?	Read the enable register
:PRESet	Return status registers to default states.

6.5.2.3.3 DISPlay subsystem commands

Command	Description
DISPlay	Path to DISPlay subsystem. (SCPI Vol.2 §8)
:BRIGHtness <value>	Set the display birghtness. (SCPI Vol.2 §8.2)
:BRIGHtness?	Return the display birghtness value. (SCPI Vol.2 §8.2)
:CONTRast <value>	Set the display contrast. (SCPI Vol.2 §8.4)
:CONTRast?	Return the display conrast value. (SCPI Vol.2 §8.4)

Commands for PM100D only

6.5.2.3.4 CALibration subsystem commands

Command	Description
CALibration	Path to CALibration subsystem. (SCPI Vol.2 §5)
:STRing?	Returns a human readable calibration string. This is a query only command. The response is formatted as string response data.

6.5.2.3.5 SENSE subsystem commands

Command	Description
[SENSE]	Path to SENSE subsystem. (SCPI Vol.2 §18)
AVERage	
[:COUNT] <value>	Sets the averaging rate (1 sample takes approx. 3ms)
[:COUNT]?	Queries the averaging rate
CORRection	
[:LOSS[:INPut[:MAGNitude]]]	Sets a user attenuation factor in dB
{MINimum MAXimum DEFault <numeric_value>}	
[:LOSS[:INPut[:MAGNitude]]]?	Queries the user attenuation factor
[{MINimum MAXimum DEFault}]	
COLLect	
ZERO	
[:INITiate]	Performs zero adjustment routine
ABORt	Aborts zero adjustment routine
STATe?	Queries the zero adjustment routine state
MAGNitude?	Queries the zero value
BEAMdiameter {MINimum MAXimum DEFault <numeric_value>[mm]}	Sets the beam diameter in mm
BEAMdiameter? [{MINimum MAXimum DEFault}]	Queries the beam diameter
WAVelength {MINimum MAXimum <numeric_value>[nm]}	Sets the operation wavelength in nm
WAVelength? [{MINimum MAXimum}]	Queries the operation wavelength

<pre> POWER [:PDIOde] [:RESPonse] {MINimum MAXimum DEFault <numeric_value>[A]} [:RESPonse]? [{MINimum MAXimum DEFault}] :THERmopile [:RESPonse] {MINimum MAXimum DEFault <numeric_value>[V]} [:RESPonse]? [{MINimum MAXimum DEFault}] ENERgy [:PYRO] [:RESPonse] {MINimum MAXimum DEFault <numeric_value>[V]} [:RESPonse]? [{MINimum MAXimum DEFault}] </pre>	<p>Sets the photodiode response value in A/W</p> <p>Queries the photodiode response value</p> <p>Sets the thermopile response value in V/W</p> <p>Queries the thermopile response value</p> <p>Sets the pyro-detector response value in V/J</p> <p>Queries the pyro-detectro response value</p>
<pre> CURRent[:DC] RANGE AUTO {OFF 0 ON 1} AUTO? [:UPPer] {MINmum MAXimum <numeric_valuje>[A]} [:UPPer]? [{MINimum MAXimum}] REFeRence {MINimum MAXimum DEFault <numeric_value>[A]} </pre>	<p>Switches the auto-ranging function on and off</p> <p>Queries the auto-ranging function state</p> <p>Sets the current range in A</p> <p>Queries the current range</p> <p>Sets a delta reference value in A</p>

<p>REFEreNce? [{MINimum MAXimum DEFault}]</p> <p>STATe {OFF 0 ON 1}</p> <p>STATe?</p>	<p>Queries the delta reference value</p> <p>Switches to delta mode</p> <p>Queries the delta mode state</p>
<p>ENERgy</p> <p>RANGE</p> <p>[:UPPer] {MINmum MAXimum <numeric_valuJe>[J]}</p> <p>[:UPPer]? [{MINimum MAXimum}]</p> <p>REFereNce {MINimum MAXimum DEFault <numeric_value>[J]}</p> <p>REFereNce? [{MINimum MAXimum DEFault}]</p> <p>STATe {OFF 0 ON 1}</p> <p>STATe?</p>	<p>Sets the energy range in J</p> <p>Queries the energy range</p> <p>Sets a delta reference value in J</p> <p>Queries the delta reference value</p> <p>Switches to delta mode</p> <p>Queries the delta mode state</p>
<p>FREQuency</p> <p>Range</p> <p>[UPPer]?</p> <p>LOWer?</p>	<p>Queries the frequency range</p>
<p>POWEr[:DC]</p> <p>RANGE</p> <p>AUTO {OFF 0 ON 1}</p> <p>AUTO?</p> <p>[:UPPer] {MINmum MAXimum <numeric_valuJe>[W]}</p> <p>[:UPPer]? [{MINimum MAXimum}]</p> <p>REFereNce {MINimum MAXimum DEFault <numeric_value>[W]}</p> <p>REFereNce? [{MINimum MAXimum DEFault}]</p> <p>STATe {OFF 0 ON 1}</p>	<p>Switches the auto-ranging function on and off</p> <p>Queries the auto-ranging function state</p> <p>Sets the current range in W</p> <p>Queries the current range</p> <p>Sets a delta reference value in W</p> <p>Queries the delta reference value</p> <p>Switches to delta mode</p>

<p>STATE?</p> <p>UNIT {W DBM}</p> <p>UNIT?</p>	<p>Queries the delta mode state</p> <p>Sets the power unit W or dBm</p> <p>Queries the power unit</p>
<p>VOLTage[:DC]</p> <p>RANGE</p> <p>AUTO {OFF 0 ON 1}</p> <p>AUTO?</p> <p>[:UPPer] {MINimum MAXimum <numeric_value>[V]}</p> <p>[:UPPer]? [{MINimum MAXimum}]</p> <p>REference {MINimum MAXimum DEFault <numeric_value>[V]}</p> <p>REference? [{MINimum MAXimum DEFault}]</p> <p>STATE {OFF 0 ON 1}</p> <p>STATE?</p>	<p>Switches the auto-ranging function on and off</p> <p>Queries the auto-ranging function state</p> <p>Sets the current range in V</p> <p>Queries the current range</p> <p>Sets a delta reference value in V</p> <p>Queries the delta reference value</p> <p>Switches to delta mode</p> <p>Queries the delta mode state</p>
<p>PEAKdetector</p> <p>[:THReshold] {MINimum MAXimum DEFault <numeric_value>}</p> <p>[:THReshold]? [{MINimum MAXimum DEFault}]</p>	<p>Sets the trigger level in % for the energy mode</p> <p>Queries the trigger level setting</p>

Commands for PM100D / PM100USB only

6.5.2.4 INPut subsystem commands

Command	Description
INPut [:PDIode] :FILTer [:LPASs] [STATe] {OFF 0 ON 1} [STATe]?	Sets the bandwidth of the photodiode input stage Queries the bandwidth of the photodiode inut stage
:THERmopile :ACCElerator [STATe] {OFF 0 ON 1} [STATe]? :TAU {MINimum MAXimum DEFault <numeric_value>[s]} :TAU? [{MINimum MAXimum DEFault}]	Sets the thermopile accelerator state Queries the thermopile accelerator state Sets thermopile time constant $\tau_{(0.63\%)}$ in s Queries the thermopile time constant $\tau_{(0.63\%)}$ in s
:ADAPter [:TYPE] {PHOTodiode THERmal PYRo} [:TYPE]?	Sets default sensor adapter type Queries default sensor adapter type

Commands for PM100D / PM100USB only

6.5.2.4.1 Measurement commands

Command	Description
INITiate[:IMMEDIATE]	Start measurement
ABORT	Abort measurement
CONFigure[:SCALar]	
[:POWER]	Configure for power measurement
:CURRent[:DC]	Configure for current measurement
:VOLTage[:DC]	Configure for voltage measurement
:ENERgy	Configure for energy measurement
:FREQuency	Configure for frequency measurement
:PDENsity	Configure for power density measurement
:EDENsity	Configure for energy density measurement
:RESistance	Configure for sensor presence resistance measurement
:TEMPerature	Configure for sensor temperature measurement
MEASure[:SCALar]	
[:POWER]	Performs a power measurement
:CURRent[:DC]	Performs a current measurement
:VOLTage[:DC]	Performs a voltage measurement
:ENERgy	Performs a energy measurement
:FREQuency	Performs a frequency measurement
:PDENsity	Performs a power density measurement
:EDENsity	Performs a energy density measurement
:RESistance	Performs a sensor presence resistance measurement
:TEMPerature	Performs a sensor temperature measurement
FETCh?	Read last measurement data (SCPI Vol.2 §3.2)
READ?	Start new measurement and read data (SCPI Vol.2 §3.3)
CONFigure?	Query the current measurement configuration.

Commands for PM100D / PM100USB only

6.6 Maintenance and Repair

6.7 Maintenance

Protect the PM100A from adverse weather conditions. The PM100A is not water resistant. Prevent the unit from shock, the analog needle meter contains sensitive mechanics that may misalign.

Attention

To avoid damage to the PM100A, do not expose it to spray, liquids or solvents!

The unit does not need a regular maintenance by the user.

If necessary the unit and the display can be cleaned with a cloth dampened with water. Use 'ESD cleaner' dampened cloth for the display glass, this prevents that the needle reacts on static influences like striking over the glass.

The PM100A does not contain any modules that could be repaired by the user himself. If a malfunction occurs, the whole unit has to be sent back to *Thorlabs*. Do not remove covers!

To guarantee the specifications given in chapter 7.3 over a long period it is recommended to have the unit calibrated by *Thorlabs* every year.

6.8 Troubleshooting

In case that your PM100A shows malfunction please check the following items:

- ◆ Unit does not work at all (no display at the front):
 - PM100A turned on?
 - Press On switch in the left side panel.
 - PM100A battery discharged / defect
 - Plug in AC Adapter
- ◆ Unit automatically switches off
 - Check auto-shutoff setting
 - Check battery charging symbol
 - Plug in AC Adapter
- ◆ Power reading is negative
 - A photodiode or thermal sensor is connected
 - Check if the unit is in relative measurement mode
 - Conduct the dark current adjustment procedure
 - A photodiode is connected
 - Check the polarity of the connected photodiode
 - A thermal element is connected
 - Check the polarity of the connected thermal element
- ◆ Mechanical needle display doesn't show zero, when unit is switched off
 - Adjust needle to zero with the screw in the front panel
 - Check that the unit is switched off prior to adjusting!
- ◆ Needle deflection doesn't map with digital read out
 - The specified accuracy for the analog meter is $\pm 3\%$ full scale, this is $1\frac{1}{2}$ division marks. This accuracy should be given for an temperature operating range between 10°C to 35°C .
 - There is a software supplied with the instrument to adjust the needle deflection to a higher accuracy ($< \pm 1\%$ f.s.) for a specific ambient temperature. Therefore connect the PM100A via USB to a PC and run the 'PM100A Needle-Wizard' software.

If you don't find the error source by means of the trouble shooting list please first contact the [Thorlabs-Hotline \(europa@thorlabs.com\)](mailto:europa@thorlabs.com) before sending the PM100D for checkup and repair to **Thorlabs** - Germany.

➔ (refer to section 7.7, 'Addresses" on page 63)

7 Appendix

7.1 Warranty

Thorlabs warrants material and production of the PM100A for a period of 24 months starting with the date of shipment. During this warranty period *Thorlabs* will see to defaults by repair or by exchange if these are entitled to warranty.

For warranty repairs or service the unit must be sent back to *Thorlabs* or to a place determined by *Thorlabs*. The customer will carry the shipping costs to *Thorlabs*, in case of warranty repairs *Thorlabs* will carry the shipping costs back to the customer.

If no warranty repair is applicable the customer also has to carry the costs for back shipment.

In case of shipment from outside EU duties, taxes etc. which should arise have to be carried by the customer.

Thorlabs warrants the hard- and software determined by *Thorlabs* for this unit to operate fault-free provided that they are handled according to our requirements. However, *Thorlabs* does not warrant a fault free and uninterrupted operation of the unit, of the soft- or firmware for special applications nor this instruction manual to be error free. *Thorlabs* is not liable for consequential damages.

Restriction of warranty

The warranty mentioned before does not cover errors and defects being the result of improper treatment, software or interface not supplied by us, modification, misuse or operation outside the defined ambient stated by us or unauthorized maintenance.

Further claims will not be consented to and will not be acknowledged. *Thorlabs* does explicitly not warrant the usability or the economical use for certain cases of application.

Thorlabs reserves the right to change this instruction manual or the technical data of the described unit without notice.

7.2 Certifications and compliances

Certifications and compliances

Category	Standards or description	
EC Declaration of Conformity – EMC	Meets intent of Directive 89/336/EEC for Electromagnetic Compatibility. Compliance was demonstrated to the following specifications as listed in the Official Journal of the European Communities:	
	EN 61326:1997 +A1:1998 +A2:2001 +A3:2003	Electrical equipment for measurement, control and laboratory use – EMC requirements: Immunity: complies with immunity test requirements for equipment intended for use in industrial locations ¹ . Emission: complies with EN 55011 Class B Limits ^{1,3} , IEC 610003-2 and IEC 61000-3-3.
	IEC 61000-4-2	Electrostatic Discharge Immunity (Performance criterion C)
	IEC 61000-4-3	Radiated RF Electromagnetic Field Immunity (Performance Criterion A) ⁵
	IEC 61000-4-4	Electrical Fast Transient / Burst Immunity (Perf. Criterion C)
	IEC 61000-4-5	Power Line Surge Immunity (Performance Criterion A)
	IEC 61000-4-6	Conducted RF Immunity (Performance Criterion A)
	IEC 61000-4-8	Power Frequency Magnetic Field Immunity (Perf. Criterion A)
	IEC 61000-4-11	Voltage Dips, Short Interruptions and Voltage Variations Immunity (Performance Criterion A / C ⁶)
	IEC 61000-3-2	AC Power Line Harmonic Emissions
	IEC 61000-3-3	Voltage Fluctuations and Flicker
FCC EMC Compliance	Emissions comply with the Class B Limits of FCC Code of Federal Regulations 47, Part 15, Subpart B ^{1,3} .	
EC Declaration of Conformity - Low Voltage	Compliance was demonstrated to the following specification as listed in the Official Journal of the European Communities: Low Voltage Directive 73/23/EEC, amended by 93/68/EEC	
	EN 61010-1:2001	Safety requirements for electrical equipment for measurement, control and laboratory use.
U.S. Nationally Recognized Testing Laboratory Listing	UL 61010-1 2 nd ed.	Safety requirements for electrical equipment for measurement, control, and laboratory use.
	ISA-82:02.01	Safety requirements for electrical equipment for measurement, control, and laboratory use.
Canadian Certification	CAN/CSA C22.2 No. 61010-1-04	Safety requirements for electrical equipment for measurement, control, and laboratory use.
Additional Compliance	IEC 61010-1:2001	Safety requirements for electrical equipment for measurement, control, and laboratory use.
Equipment Type	Test and measuring	
Safety Class	Class I equipment (as defined in IEC 60950-1:2001)	

¹ Compliance demonstrated using high-quality shielded interface cables shorter than 3 meters.

³ Emissions, which exceed the levels required by these standards, may occur when this equipment is connected to a test object.

⁵ MOD IN port capped at IEC 61000-4-3 test.

⁶ Performance Criterion C was reached at additional test levels according to EN 61326-1:2006 table 2

7.3 Technical data

General Data	
Detector Compatibility	Photodiode Sensors S100C Series Thermal Sensors S300C Series Photodiodes (max. 5mA) Thermopiles (max. 1V)
Display Type	Graphical LCD 132 x 32 pixels + Mechanical Analog Needle
Viewing Area	48.2 x 13.2 mm + 90,0 x 42,0 mm
Display Update Rate (max)	20 Hz
Display Format	Numerical, Mechanical Analog Needle
Backlight Display and Keypad	LED
Dimensions (H x W x D) Overall	183 x 109 x 40 mm ³
Options	Kickstand; 1/4-20 Post thread
Weight	<0.5 kg
Operating Temperature	0°C - +40°C
Storage Temperature	-40°C - +70°C
Current Input (Photodiode Sensors)	
Connector	DB9F, left side
Units	W
Measurement Ranges	6 decades; 50 nA - 5 mA Ranges selectable in W, sensor depending
Display Resolution	1 pA / responsivity value (A/W)
AD Converter	16 bit
Accuracy	+/-0.2% f.s. (5µA - 5mA); +/-0.5% f.s. (50nA) +/-3% f.s. Analog Meter
Bandwidth	DC - 100kHz, depending on sensor and settings
Wavelength Correction	nm (A/W)
Voltage Input (Thermopile Sensors)	
Connector	DB9F, left side
Units	W
Measurement Ranges	4 decades; 1 mV - 1V Ranges selectable in W, sensor dependent
Display Resolution	1 µV / responsivity value (V/W)
AD Converter	16 bit
Accuracy	+/-0.5% f.s. (10mV - 1V); +/-1% f.s. (1mV) +/-3% f.s. Analog Meter
Bandwidth	DC - 10Hz, depending on sensor and settings
Time Constant Correction Range	1s – 30s
Wavelength Correction	Sensor depending; nm, (V/W)
Beam Diameter Setting	N/A
Analog Outputs	
Connector	SMA, left side
Signal	amplified input signal – not corrected
Voltage Range	0 ... 2V
Accuracy	+/-3%
Bandwidth	up to 100kHz, depending on sensor and settings
Sensor Temperature Control	
Supported temperature sensor	Thermistor
Temperature measurement range	-10°C ... +80°C (displayed via interface only)

Sound	
Type	Speaker 300Hz - 5kHz
Function	Laser tuning support, console function support
Interface	
Type	USB2.0
Connector	Mini USB, left side
Power Management	
Battery	LiPo 3.7V 1300mAh
Charger / DC Input	5V/1A
Accessories	
Hardcase	✓
Instrument Drivers on USB Stick	✓
Application Software on USB Stick	✓
User Manual	✓

Current Input Photodiode Sensors

Current Range	Display Resolution	Measurement Accuracy	Analog Output Gain	Analog Output Bandwidth
5 mA	1 μ A	+/- 0.2% f.s.	4×10^2 V/A	100 kHz / 25 Hz
500 μ A	100 nA	+/- 0.2% f.s.	4×10^3 V/A	100 kHz / 25 Hz
50 μ A	10 nA	+/- 0.2% f.s.	4×10^4 V/A	100 kHz / 25 Hz
5 μ A	1 nA	+/- 0.2% f.s.	4×10^5 V/A	100 kHz / 25 Hz
500 nA	100 pA	+/- 0.2% f.s.	4×10^6 V/A	10 kHz / 25 Hz
50 nA	10 pA	+/- 0.5% f.s.	4×10^7 V/A	1 kHz / 25 Hz

Voltage Input Thermal Sensors

Voltage Range	Display Resolution	Measurement Accuracy	Analog Output Gain	Analog Output Bandwidth
1 V	100 μ V	+/- 0.5% f.s.	2×10^0	10 Hz
100 mV	10 μ V	+/- 0.5% f.s.	2×10^1	10 Hz
10 mV	1 μ V	+/- 0.5% f.s.	2×10^2	7 Hz
1 mV	0.1 μ V	+/- 1.0% f.s.	2×10^3	0.7 Hz

7.4 Pin Assignment of the Sensor Connector

The PM100A is capable to support custom made detectors. Please read carefully the following instruction prior to connecting a self made sensor.

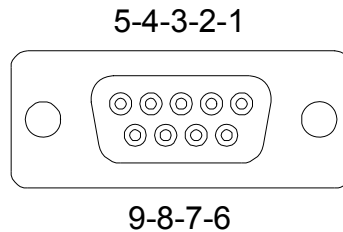

Figure 13 Pin assignment of the sensor connector jack (female)

pin connection

- | | |
|----------|--|
| 3 | photodiode ground (anode), thermal sensor ground, analog ground |
| 4 | photodiode cathode |
| 5 | n.c. |
| 8 | thermal sensor + |
| 7 | PRESENT connect this pin via a 1kΩ – 10kΩ resistor to Pin 3 (AGND) |
| 1 | +5V drive max. 50mA from this pin |
| 6 | DGND |
| 9 | n.c. |

The following described pin is uniquely used for the memory in the sensor head and may not be used. Connecting this pin may cause malfunction of the PM100D.

- | | |
|----------|--------------------|
| 2 | EEPROM Digital I/O |
|----------|--------------------|

7.5 Thorlabs 'End of Life' policy (WEEE)

As required by the WEEE (Waste Electrical and Electronic Equipment Directive) of the European Community and the corresponding national laws, Thorlabs offers all end users in the EC the possibility to return 'end of life' units without incurring disposal charges.

This offer is valid for Thorlabs electrical and electronic equipment

- sold after August 13th 2005
- marked correspondingly with the crossed out 'wheelie bin' logo (see Figure 14)
- sold to a company or institute within the EC
- currently owned by a company or institute within the EC
- still complete, not disassembled and not contaminated

As the WEEE directive applies to self contained operational electrical and electronic products, this 'end of life' take back service does not refer to other Thorlabs products, such as

- pure OEM products, that means assemblies to be built into a unit by the user (e. g. OEM laser driver cards)
- components
- mechanics and optics
- left over parts of units disassembled by the user (PCB's, housings etc.).

If you wish to return a Thorlabs unit for waste recovery, please contact Thorlabs or your nearest dealer for further information.

7.5.1 Waste treatment on your own responsibility

If you do not return an 'end of life' unit to Thorlabs, you must hand it to a company specialized in waste recovery. Do not dispose of the unit in a litter bin or at a public waste disposal site.

7.5.2 Ecological background

It is well known that WEEE pollutes the environment by releasing toxic products during decomposition. The aim of the European RoHS directive is to reduce the content of toxic substances in electronic products in the future.

The intent of the WEEE directive is to enforce the recycling of WEEE. A controlled recycling of end of life products will thereby avoid negative impacts on the environment.



Figure 14 Crossed out 'wheelie bin' symbol

7.6 List of figures

Figure 1	Physical Overview Front Panel	10
Figure 2	Physical Overview Side Panel	10
Figure 3	Rear View	11
Figure 4	Physical Overview Bottom View	11
Figure 5	Display Setup	12
Figure 6	Wavelength Correction	16
Figure 7	Zeroing	16
Figure 8	Attenuation	17
Figure 9	Relative Measurement	18
Figure 10	Display Options	18
Figure 11	Photodiode Mode	20
Figure 12	Tune Sound	22
Figure 13	Pin assignment of the sensor connector jack (female)	59
Figure 14	Crossed out 'wheelie bin' symbol	61

7.7 Addresses

Our Company is represented by several distributors and sales offices throughout the world.

Europe

Thorlabs GmbH
Hans-Boeckler-Str. 6
D-85221 Dachau
Germany

Sales and Support

Phone: +49 (0) 8131 / 5956-0
Fax: +49 (0) 8131 / 5956-99
Email: europa@thorlabs.com
Web: www.thorlabs.com

Japan

Thorlabs, Inc.
Higashi Ikebukuro Q Building 1st floor
2-23-2, Higashi Ikebukuro, Toshimaku
Tokyo 170-0013
Japan

Sales and Support

Phone: +81-3-5979-8889
Fax: +81-3-5979-7285
Email: sales@thorlabs.jp
Web: www.thorlabs.jp

USA

Thorlabs, Inc.
435 Route 206 North
Newton, NJ 07860
USA

Sales and Support

Phone: 1-973-579-7227
Fax: 1-973-300-3600
Email: sales@thorlabs.com
Email: techsupport@thorlabs.com
Web: www.thorlabs.com

Please call our hotlines, send an Email to ask for your nearest distributor or just visit our homepage

<http://www.thorlabs.com>