

# Weslo<sup>®</sup> Air Strider

Model No. WLAW55071

Serial No. \_\_\_\_\_

Write the serial number in the space above for future reference.

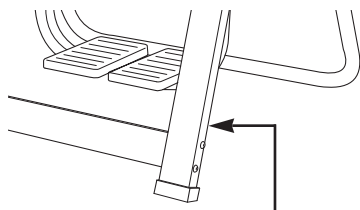

Serial Number Decal

## QUESTIONS?

As a manufacturer, we are committed to providing complete customer satisfaction. If you have questions, or find that there are missing or damaged parts, we will guarantee complete satisfaction through direct assistance from our factory.

TO AVOID UNNECESSARY DELAYS, PLEASE CALL DIRECT TO OUR TOLL-FREE CUSTOMER HOT LINE. The trained technicians on our customer hot line will provide immediate assistance, free of charge to you.

CUSTOMER HOT LINE:

**1-800-999-3756**

Mon.-Fri., 6 a.m.-6 p.m. MST



Patent Pending

## CAUTION

Read all precautions and instructions in this manual before using this equipment. Save this manual for future reference.

# USER'S MANUAL

---

# TABLE OF CONTENTS

IMPORTANT PRECAUTIONS .....	.2
BEFORE YOU BEGIN .....	.3
ASSEMBLY .....	.4
HOW TO USE THE AIR STRIDER .....	.7
STORAGE AND TROUBLE-SHOOTING .....	.8
CONDITIONING GUIDELINES .....	.9
PART LIST .....	.10
EXPLODED DRAWING .....	.11
ORDERING REPLACEMENT PARTS .....	.Back Cover
LIMITED WARRANTY .....	.Back Cover

---

## IMPORTANT PRECAUTIONS

**WARNING:** To reduce the risk of serious injury, read the following important precautions before using the AIR STRIDER.

1. It is the responsibility of the owner to ensure that all users of the AIR STRIDER are adequately informed of all warnings and precautions.
2. Read all instructions in this manual before using the AIR STRIDER.
3. Use the AIR STRIDER only as described in this manual.
4. Use the AIR STRIDER only on a level surface. Cover the floor beneath the AIR STRIDER to protect the floor or carpet.
5. Be sure that there are no persons or obstacles in front of or behind the AIR STRIDER.
6. Inspect and tighten all parts regularly. Replace any worn parts immediately.
7. Keep children and pets away from the AIR STRIDER at all times.
8. The AIR STRIDER should not be used by persons weighing more than 250 pounds.
9. Keep hands and feet away from moving parts.
10. Do not wear loose clothing that could become caught on the AIR STRIDER.
11. Always wear athletic shoes for foot protection when exercising on the AIR STRIDER.
12. When you are getting onto and off the AIR STRIDER, tighten the resistance dials, hold the handles firmly, and be sure that your body weight is centered directly over the pedals.
13. If you feel faint, dizzy, or short of breath while exercising, stop immediately and begin cooling down.
14. When folding the AIR STRIDER for storage, hold the resistance dials to prevent your hands from being pinched.
15. The AIR STRIDER is intended for home use only. Do not use the AIR STRIDER in any commercial, rental, or institutional setting.

**WARNING:** Before beginning this or any exercise program, consult your physician. This is especially important for persons over the age of 35 or persons with pre-existing health problems. Read all instructions before using. ICON assumes no responsibility for personal injury or property damage sustained by or through the use of this product.

# BEFORE YOU BEGIN

Thank you for selecting the innovative WESLO® AIR STRIDER. The AIR STRIDER blends advanced engineering with contemporary styling to provide you with a no-impact, total body workout in the convenience and privacy of your own home.

**For your benefit, read this manual carefully before using the AIR STRIDER.** If you have questions after reading the manual, call our Customer Service Department toll-free at 1-800-999-3756, Monday through Friday, 6 a.m. until 6 p.m. Mountain Time

(excluding holidays). To help us assist you, please note the product model number and serial number before calling. The model number is WLAW55071. The serial number can be found on a decal attached to the AIR STRIDER (see the front cover of this manual for the location of the decal).

Before reading further, please review the drawing below and familiarize yourself with the parts that are labeled.

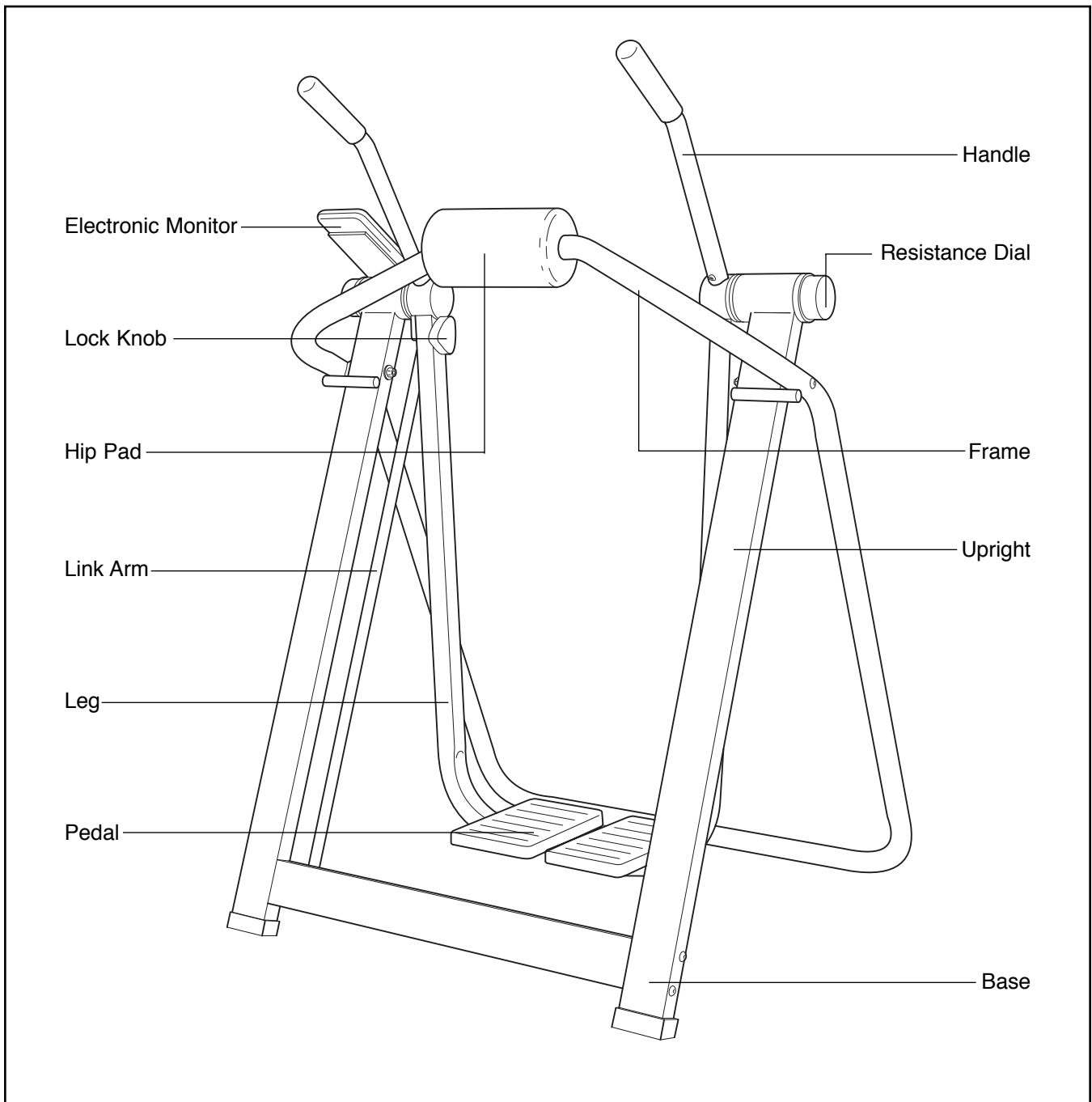

# ASSEMBLY

**Assembly requires two people.** Place all parts of the AIR STRIDER in a cleared area and remove the packing materials. Do not dispose of the packing materials until assembly is completed.

Read through all steps before beginning assembly. As you assemble the AIR STRIDER, make sure that all parts are oriented as shown in the drawings. Tighten all parts as you assemble them, unless instructed to do otherwise. Refer to the drawings below to identify the small hardware used in assembly. **Note: If a part is not found in the parts bag, check to see if it has been pre-attached.**

**Assembly requires two adjustable wrenches** , **a hammer** , **and a phillips screwdriver**  (not included).

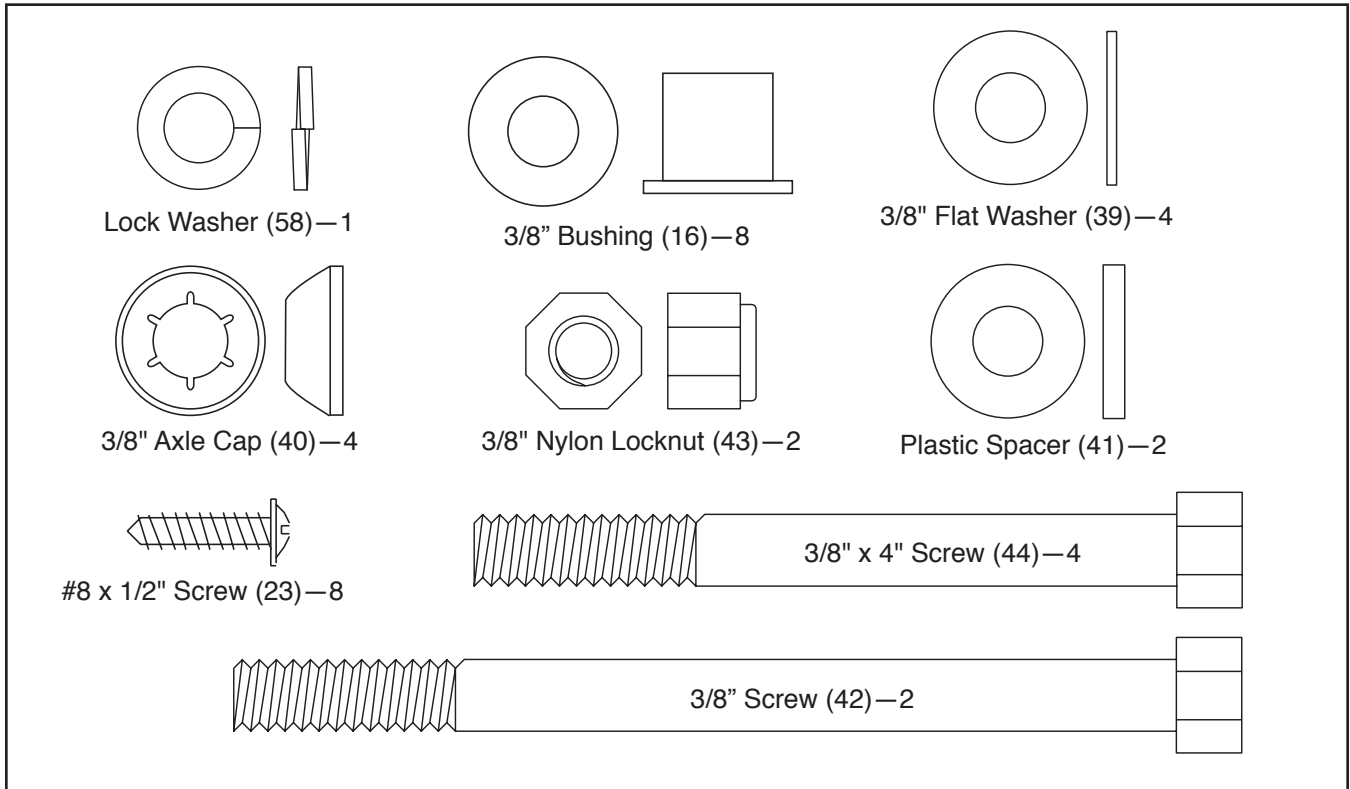

**1. Read all instructions at the top of this page before beginning assembly.**

Refer to the drawing at the right and identify the Left and Right Uprights (1, 2). Note the location of the stop rods.

Turn the Crossbar (10) so the Rocker Arm (9) is at the top. Attach the Crossbar to the Left Upright (1) with two 3/8" x 4" Screws (44) and two 3/8" Flat Washers (39). **Do not tighten the Screws yet.** Attach the Crossbar to the Right Upright (2) in the same manner.

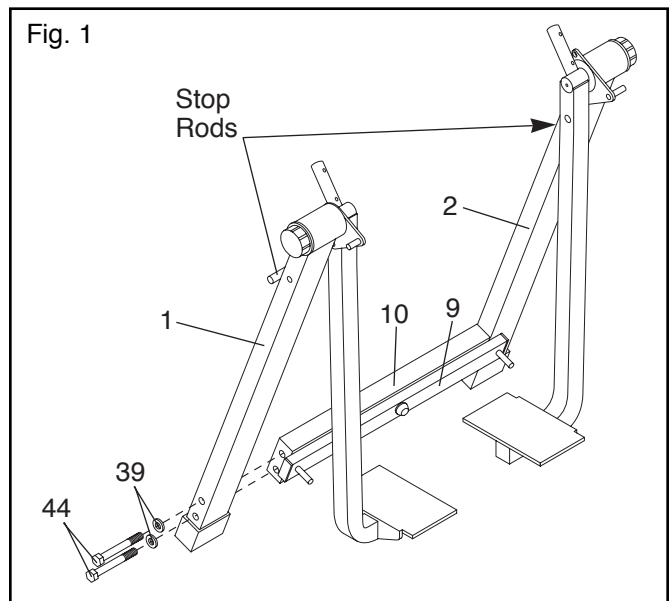

- Refer to figure 2b. Slide a Finger Guard (54) onto the pins on the Left Pivot Bracket (7). Note: The Finger Guards may already be attached.

Find the Left Link Arm (11), which is labeled with a "left" sticker. Make sure that there are two 3/8" Bushings (16) in each end of the Link Arm. Slide one end of the Link Arm onto the indicated pin on the Left Pivot Bracket (7). **Make sure that the Link Arm is turned as shown in figure 2c.** Tap a 3/8" Axle Cap (40) onto the pin. Slide the other end of the Link Arm onto the pin on the Rocker Arm (9). (Note: It may be necessary to pivot the Rocker Arm and the Left Leg [1] slightly.) Tap a 3/8" Axle Cap (40) onto the pin.

Attach the other Finger Guard and the Right Link Arm (not shown) in the same manner.

- Attach the Right Frame Section (6) to the Right Upright (2) with a 3/8" Screw (42), a Plastic Spacer (41), and a 3/8" Nylon Locknut (43). **Do not tighten the Nylon Locknut yet.**

- Slide the Hip Pad (28) onto the Left Frame Section (5).

Slide the Left and Right Frame Sections (5, 6) together. Make sure that the indicated hole is accessible. If necessary, slide the Hip Pad (28) to the side. Attach the Frame Sections with two #8 x 1/2" Screws (23). **Do not tighten the Screws yet.**

Attach the Left Frame Section (5) to the Left Upright (1) with a 3/8" Screw (42), a Plastic Spacer (41), and a 3/8" Nylon Locknut (43).

**Tighten all parts used in steps 1, 3, and 4.**

Slide the Hip Pad (28) so it is centered on the Frame Sections (5, 6).

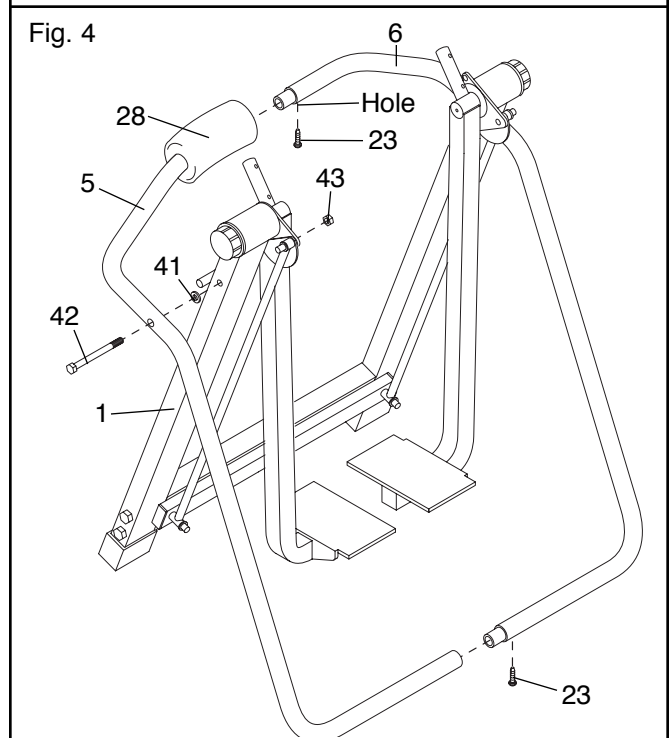
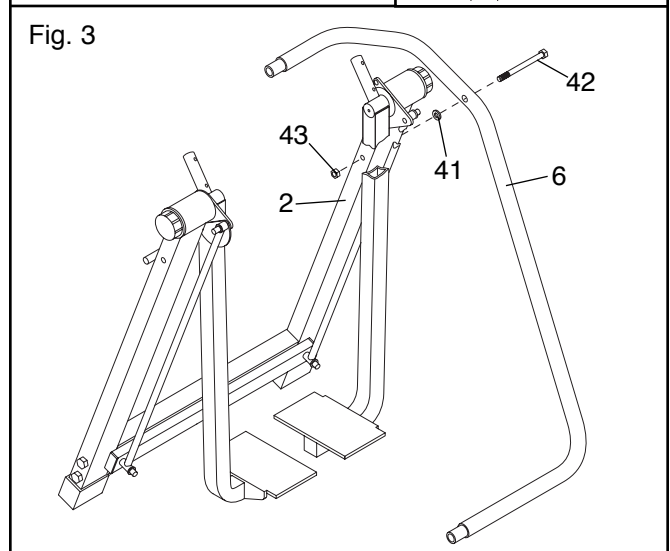
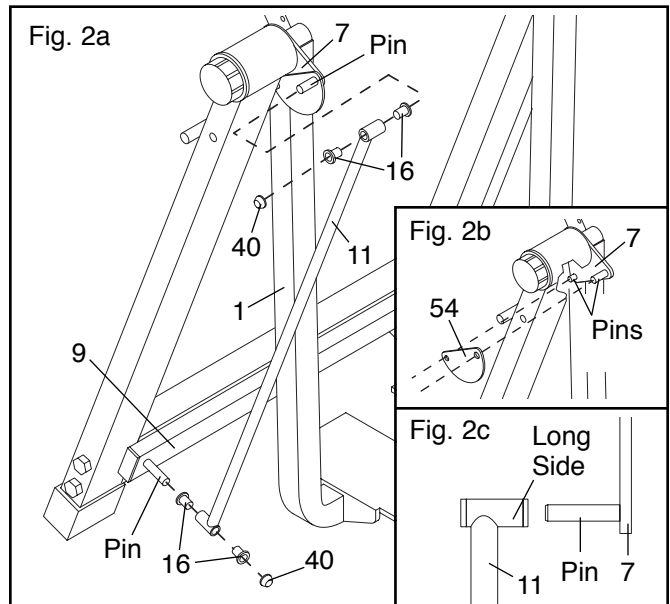

- Peel the backing off one of the Pedal Covers (27). Center the Pedal Cover on the plate on the Left Leg (1). Press the Pedal Cover firmly in place.

Attach the other Pedal Cover (27) to the plate on the Right Leg (2) in the same manner.

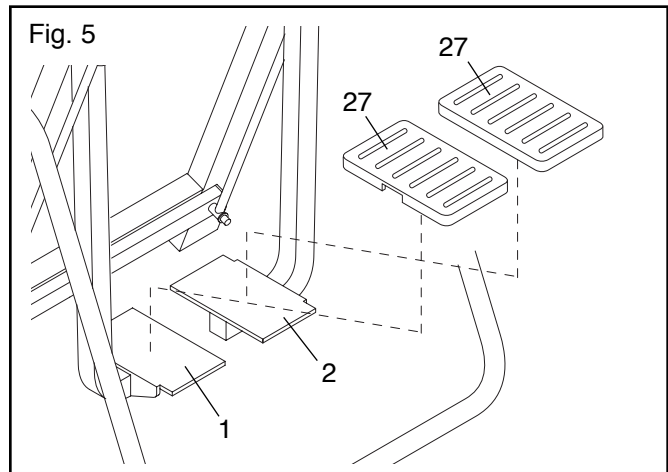

- Refer to figure 6b. The Electronic Monitor (37) requires two “AA” batteries (not included). Press the tab on the battery cover and remove the battery cover. Insert two new “AA” batteries into the Monitor. **Make sure that the batteries are turned as shown.** Replace the battery cover.

Remove the two indicated #8 x 1/2” Screws (23) from the Right Upright (2). Attach the Monitor Bracket (45) to the Right Upright with the Screws. Note: If the Electronic Monitor (37) does not operate properly, see HOW TO ADJUST THE REED SWITCH on page 8.

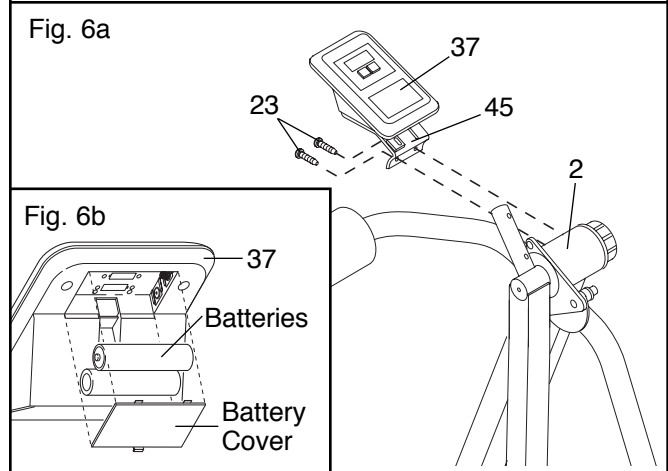

- Slide one of the Sleeves (59) onto the Left Leg (3). Position the Sleeve so that the holes in the Left Leg are visible through the slot in the Sleeve. Slide one of the Handles (13) over the Sleeve and onto the Left Leg. Attach the Handle with four #8 x 1/2” Screws (23).

Attach the other Sleeve (59) and Handle (13) to the Right Leg (4) in the same manner.

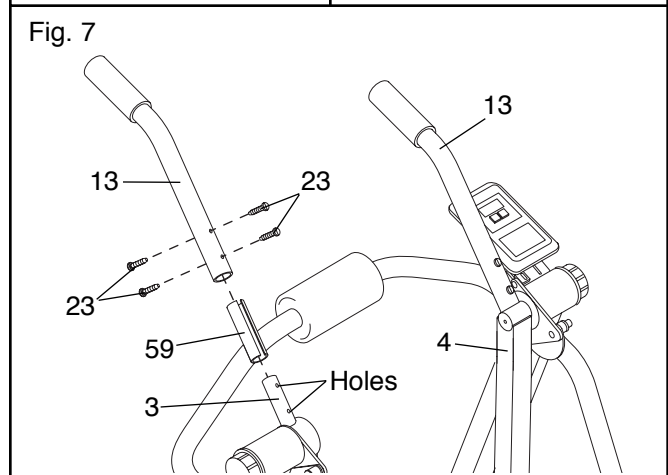

- Attach the Right Leg Cover (31) to the Right Leg (4) with a Tree Fastener (32).

Attach the Left Leg Cover (30) to the Left Leg (3) in the same manner.

Slide the Lock Washer (58) onto the Lock Knob (25). Insert the Lock Knob into the hole near the top of the Right Leg (4). Tighten the Lock Knob into the Right Pivot Bracket (8).

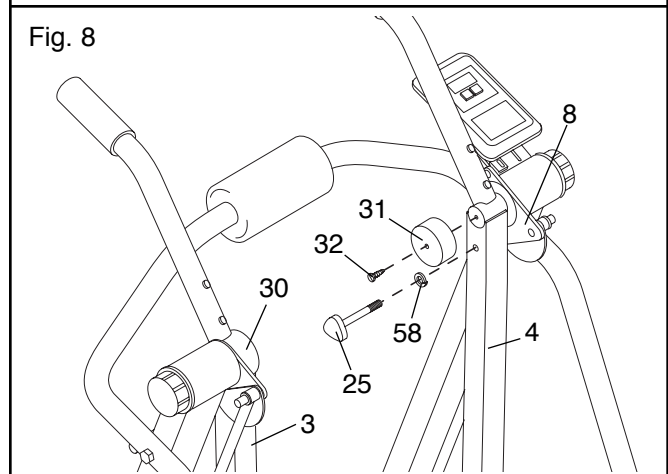

Note: Extra #8 x 1/2” Screws (23) may be included. **Before you use the AIR STRIDER, firmly retighten all of the parts used in assembly.**

# HOW TO USE THE AIR STRIDER

**CAUTION:** When you are getting onto and off the AIR STRIDER, always tighten the resistance dials, hold the handles firmly, and be sure that your body weight is centered directly over the pedals.

## EXERCISING ON THE AIR STRIDER

Make sure that the lock knob is tightened into the right leg and pivot bracket (see assembly step 8 on page 6). Tighten the resistance dials, hold the handles, and step onto the pedals. The proper form for exercising on the AIR STRIDER is similar to the motion of walking—move one leg forward as you move the other leg back.

For a full body workout, hold the handles as you walk, and move your arms and legs in motion with the handles and pedals. To vary the effect of the exercise on your muscles, change your stance on the AIR STRIDER. For example, stand erect or lean against the hip pad, change the position of your hands on the handles, or bend your legs slightly instead of keeping them straight.

For a lower body workout, rest your hands on the frame for balance as you move the pedals.

## RESISTANCE ADJUSTMENT

To vary the intensity of your workout, the resistance of the AIR STRIDER can be changed. To increase the resistance, turn the resistance dials clockwise. To decrease the resistance, turn the resistance dials counterclockwise.

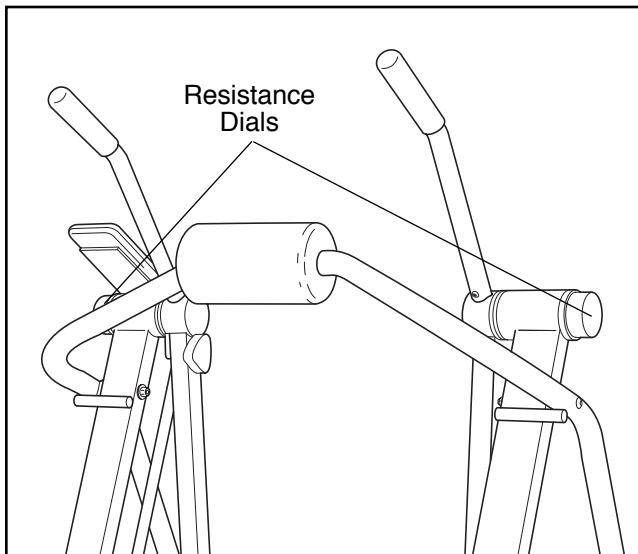

## ELECTRONIC MONITOR MODES

The simple-to-operate electronic monitor offers five different modes to provide instant exercise feedback. The five modes are described below:

**Speed**—Displays the number of repetitions you are performing per minute.

**Time**—Displays the length of time you have exercised. Note: If you stop exercising for ten seconds or longer, the time mode will pause until you resume.

**Distance**—Displays the total number of repetitions you have completed, up to “999.” The display will then reset to “0” and continue counting.

**Calories**—Displays the approximate number of Calories you have burned. Note: If the resistance is near the highest or lowest setting, the actual number of Calories you have burned will be slightly higher or lower than the number displayed.

**Scan**—Displays the speed, time, distance, and calories modes, for approximately 5 seconds each, in a repeating cycle.

## DIAGRAM OF THE ELECTRONIC MONITOR

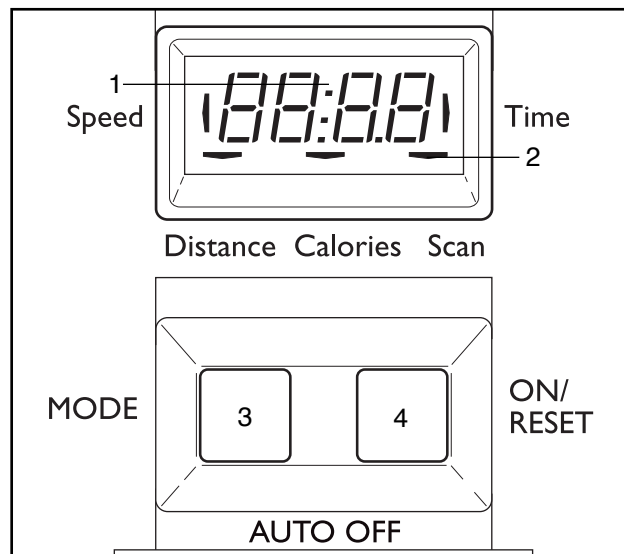

1. LCD display—Displays all modes.
2. Mode indicators—Show which mode is selected.
3. Mode button—Selects all modes.
4. On/Reset button—Turns the power on and resets all modes.

## OPERATING THE ELECTRONIC MONITOR

1. To turn on the power, press the on/reset button or simply begin exercising on the AIR STRIDER. The entire display will appear for two seconds. The electronic monitor will then be ready for operation.
2. Select one of the five modes:

**Scan mode**—When the power is turned on, the scan mode will be selected automatically. The scan mode can also be selected by repeatedly pressing the mode button. One mode indicator will show that the scan mode has been selected, and a second mode indicator will show which mode is currently displayed.

### Speed, time, distance, or calories mode—

These modes can be individually selected by repeatedly pressing the mode button. The mode indicators will show which mode has been selected. (Make sure that the scan mode is not selected.) The modes will be selected in the following order: speed, time, distance, calories, scan.

3. **The monitor has an auto-off feature to turn off the power.** If the pedals are not moved and the monitor buttons are not pressed for four minutes, the power will turn off automatically in order to conserve the batteries.

To reset the LCD display, press the on/reset button.

## STORAGE AND TROUBLE-SHOOTING

Inspect and tighten all parts of the AIR STRIDER regularly. Replace any worn parts immediately. The AIR STRIDER can be cleaned with a soft, damp cloth. Keep liquids away from the electronic monitor. Keep the monitor out of direct sunlight or the display may be damaged. Remove the batteries when storing the AIR STRIDER.

### HOW TO FOLD THE AIR STRIDER FOR STORAGE

When the AIR STRIDER is not in use, it can be folded for compact storage. To fold the AIR STRIDER, first remove the lock knob and lock washer from the right leg. Next, hold the resistance dials and fold the frame and the uprights together. **Place the AIR STRIDER in a location where it cannot fall.**

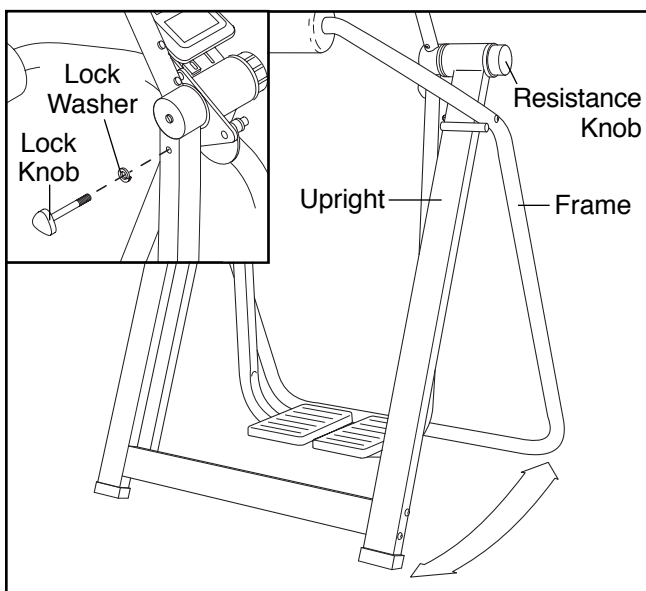

### REPLACING THE BATTERIES

If the display of the electronic monitor becomes dim, or if the monitor does not function properly, the batteries should be replaced. To replace the batteries, refer to assembly step 6 on page 6.

### HOW TO ADJUST THE REED SWITCH

If the speed and distance modes do not display correct information, the reed switch should be adjusted.

The reed switch is located below the electronic monitor (see the drawing at the right). Loosen the screw in the reed switch, move the reed switch to the side slightly, and retighten the screw. **Make sure that the reed switch does not hit the indicated magnet when the AIR STRIDER is in use.** Repeat until the speed and distance modes display correct information.

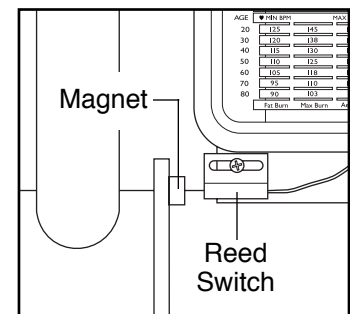



# CONDITIONING GUIDELINES

The following general guidelines will help you to plan your exercise program. Remember that proper nutrition and adequate rest are essential for successful results.

**WARNING: Before beginning this or any exercise program, consult your physician. This is especially important for individuals over the age of 35 or individuals with pre-existing health problems.**

## EXERCISE INTENSITY

Whether your goal is to burn fat or strengthen your cardiovascular system, the key to achieving the desired results is to exercise with the proper intensity. The proper intensity level can be found by using your heart rate as a guide. The chart below shows recommended heart rates for fat burning, maximum fat burning, and cardiovascular (aerobic) exercise. (This chart is also found on the console.)

HEART RATE TRAINING ZONES				
AGE	♥ MIN BPM		MAX BPM ♥	AGE
20	125	145	165	20
30	120	138	155	30
40	115	130	145	40
50	110	125	140	50
60	105	118	130	60
70	95	110	125	70
80	90	103	115	80
	Fat Burn	Max Burn	Aerobic	

To find the proper heart rate for you, first find your age on either side of the chart (ages are rounded off to the nearest ten years). Next, find the three numbers to the side of your age. The three numbers are your “training zone.” The lowest number is the recommended heart rate for fat burning; the middle number is the recommended heart rate for maximum fat burning; the highest number is the recommended heart rate for aerobic exercise.

### Fat Burning

To burn fat effectively, you must exercise at a relatively low intensity level for a sustained period of time. During the first few minutes of exercise, your body uses easily accessible carbohydrate calories for ener-

gy. Only after the first few minutes of exercise does your body begin to use stored fat calories for energy. If your goal is to burn fat, adjust your pace or the resistance until your heart rate is near the lowest number in your training zone as you exercise.

For maximum fat burning, adjust your pace or the resistance until your heart rate is near the middle number in your training zone as you exercise.

### Aerobic Exercise

If your goal is to strengthen your cardiovascular system, your exercise must be “aerobic.” Aerobic exercise is activity that requires large amounts of oxygen for prolonged periods of time. This increases the demand on the heart to pump blood to the muscles, and on the lungs to oxygenate the blood. For aerobic exercise, adjust your pace or the resistance until your heart rate is near the highest number in your training zone as you exercise.

## HOW TO MEASURE YOUR HEART RATE

To measure your heart rate, first exercise for at least four minutes. Then, stop exercising and place two fingers on your wrist as shown. Take a six-second heart-beat count, and multiply the result by 10 to find your heart rate. For example, if your six-second heart-beat count is 14, your heart rate is 140 beats per minute. (A six-second count is used because your heart rate will drop rapidly when you stop exercising.)

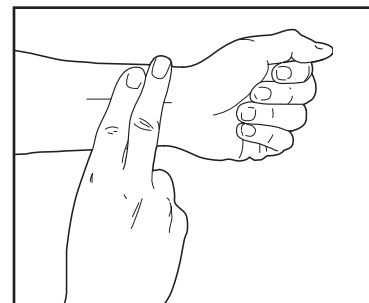

Adjust the intensity of your exercise until your heart rate is at the desired level. You can adjust the intensity of your exercise by changing your pace or by adjusting the resistance.

## WORKOUT GUIDELINES

Each workout should include the following three parts:

**A warm-up**, consisting of 5 to 10 minutes of stretching and light exercise. A proper warm-up increases the body temperature, heart rate, and circulation in preparation for strenuous exercise.

**Training zone exercise**, consisting of 20 to 30 minutes of exercising with your heart rate in your training zone.

**A cool-down**, with 5 to 10 minutes of stretching. Thorough stretching helps to offset problems caused when you stop exercising suddenly. Stretching for increased flexibility is also most effective after exercising. A proper cool-down should leave you relaxed and comfortably tired.

## EXERCISE FREQUENCY

To maintain or improve your condition, plan three workouts each week, with at least one day of rest between workouts. After a few months of regular exercise, you may complete up to five workouts each week, if desired.

Remember, the key to success is make exercise a regular and enjoyable part of your everyday life.

## PART LIST—Model No. WLAW55071

R0297A

Key No.	Qty.	Description	Key No.	Qty.	Description
1	1	Left Upright	32	2	Tree Fastener
2	1	Right Upright	33	2	Hex Bushing
3	1	Left Leg	34	2	Hub Resistance Bushing
4	1	Right Leg	35	2	Rocker Arm Endcap
5	1	Left Frame Section	36	1	Large Axle Cap
6	1	Right Frame Section	37	1	Electronic Monitor
7	1	Left Pivot Bracket	38	1	Magnet
8	1	Right Pivot Bracket	39	4	3/8" Flat Washer
9	1	Rocker Arm	40	4	3/8" Axle Cap
10	1	Crossbar	41	2	Plastic Spacer
11	1	Left Link Arm	42	2	3/8" Screw
12	1	Right Link Arm	43	2	3/8" Nylon Locknut
13	2	Handle	44	4	3/8" x 4" Screw
14	2	Resistance Dial	45	1	Monitor Bracket
15	2	Friction Disk w/Spacer Plate	46	2	Frame End Plate
16	8	3/8" Bushing	47	1	Reed Switch/Wire
17	2	Friction Cup	48	3	Console Screw
18	4	Thrust Washer	49	2	Thrust Bearing
19	6	Tension Washer	50*	1	Monitor Assembly
20	2	Snap Ring	51	2	Weld Spacer
21	2	Hub Washer (Optional)	52	1	Washer
22	2	Rubber Foot	53	1	"D" Bushing
23	16	#8 x 1/2" Screw	54	2	Finger Guard
24	2	Handgrip	55	2	Phoenix Ring
25	1	Lock Knob	56	2	1" x 1 3/4" Washer
26	1	Pivot Screw	57	2	Pushnut
27	2	Pedal Cover	58	1	Lock Washer
28	1	Hip Pad	59	2	Sleeve
29	2	Frame Endcap	#	1	User's Manual
30	1	Left Leg Cover			
31	1	Right Leg Cover			

\* Includes all parts shown in the box  
# Non-illustrated part

Note: Extra #8 x 1/2" Screws (23) may be included. Specifications are subject to change without notice. See the back cover of this manual for information about ordering replacement parts.

# EXPLODED DRAWING—Model No. WLAW55071

R0297A

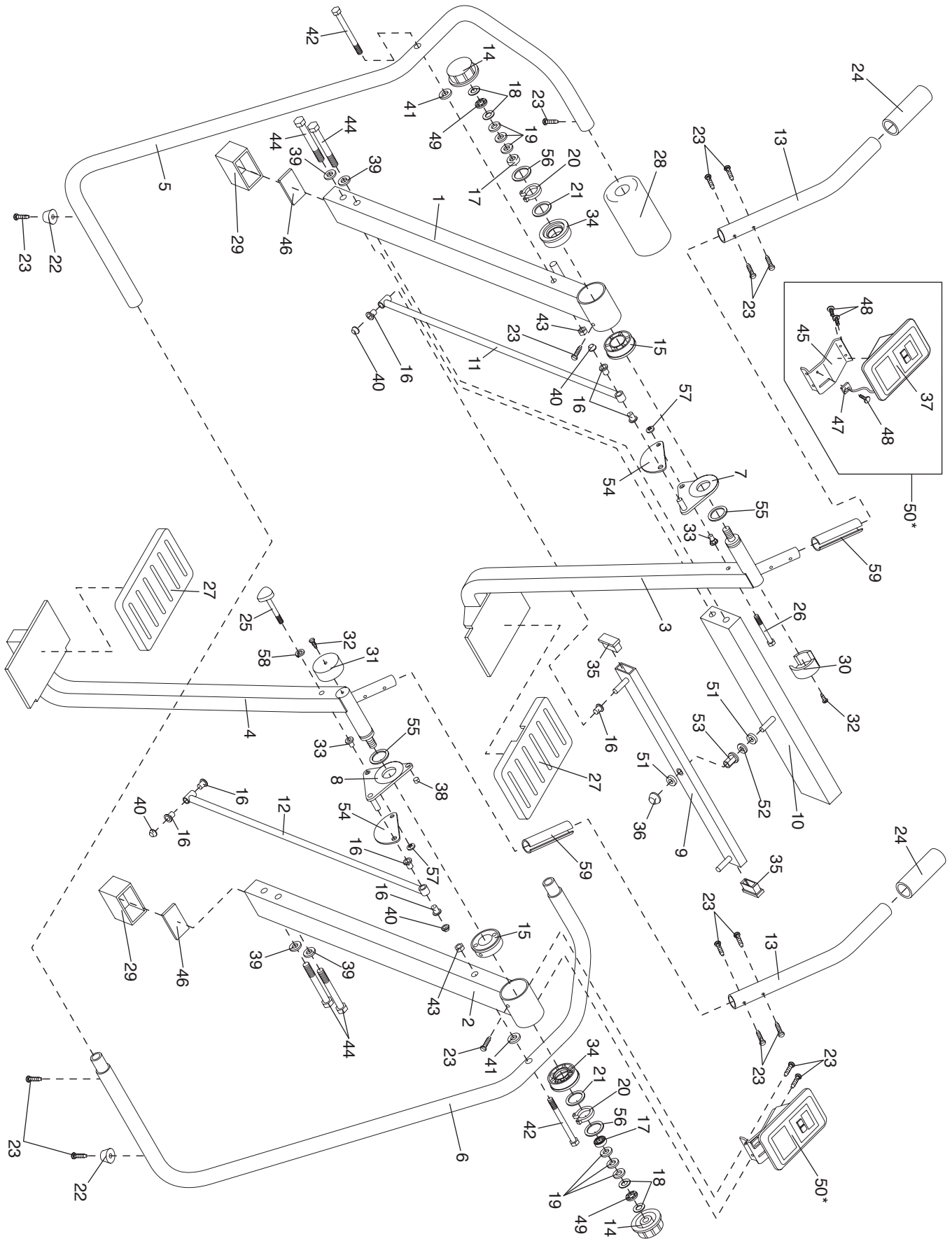

---

# HOW TO ORDER REPLACEMENT PARTS

To order replacement parts, simply call our Customer Service Department toll-free at 1-800-999-3756, Monday through Friday, 6 a.m. until 6 p.m. Mountain Time (excluding holidays). To help us assist you, please be prepared to give the following information when calling:

- The MODEL NUMBER of the product (WLAW55071).
- The NAME of the product (WESLO® AIR STRIDER).
- The SERIAL NUMBER of the product (see the front cover of this manual).
- The KEY NUMBER and DESCRIPTION of the part(s) from page 10 of this manual.

WESLO is a registered trademark of ICON Health & Fitness, Inc.

## LIMITED WARRANTY

ICON Health & Fitness, Inc. (ICON) warrants this product to be free from defects in workmanship and material, under normal use and service conditions, for a period of ninety (90) days from the date of purchase. This warranty extends only to the original purchaser. ICON's obligation under this warranty is limited to replacing or repairing, at ICON's option, the product at one of its authorized service centers. All products for which warranty claim is made must be received by ICON at one of its authorized service centers with all freight and other transportation charges prepaid, accompanied by sufficient proof of purchase. All returns must be pre-authorized by ICON. This warranty does not extend to any product or damage to a product caused by or attributable to freight damage, abuse, misuse, improper or abnormal usage or repairs not provided by an ICON authorized service center, to products used for commercial or rental purposes, or to products used as store displays. No other warranty beyond that specifically set forth above is authorized by ICON.

ICON is not responsible or liable for indirect, special or consequential damages arising out of or in connection with the use or performance of the product or damages with respect to any economic loss, loss of property, loss of revenues or profits, loss of enjoyment or use, costs of removal, installation or other consequential damages of whatsoever nature. Some states do not allow the exclusion or limitation of incidental or consequential damages. Accordingly, the above limitation may not apply to you.

The warranty extended hereunder is in lieu of any and all other warranties and any implied warranties of merchantability or fitness for a particular purpose is limited in its scope and duration to the terms set forth herein. Some states do not allow limitations on how long an implied warranty lasts. Accordingly, the above limitation may not apply to you.

This warranty gives you specific legal rights. You may also have other rights which vary from state to state.

**ICON HEALTH & FITNESS, INC., 1500 S. 1000 W., LOGAN, UT 84321-9813**