

CERTIFICATE of EU TYPE-APPROVAL

No. DK 0199.65

**FLINTAB type
5204 / 5206 / 5208 / 5218 / 5250 / 5290
DJB / DWI / RDT52A/B**

NON-AUTOMATIC WEIGHING INSTRUMENT

Issued by DELTA Danish Electronics, Light & Acoustics
EU - Notified Body No. 0199

In accordance with the requirements of the non-automatic weighing instrument regulation No. 560 of 23 June 1992 that implements, in Denmark, Council Directive 90/384/EEC.

Issued to FLINTAB S.R.L.
27, Toma Ionescu Street,
100170 Ploiesti
Romania

In respect of Non-automatic weighing instrument designated
FLINTAB type 5204 / 5206 / 5208 / 5218 / 5250 / 5290
DJB / DWI / RDT52A/B
with variants of modules.
Accuracy class III
Maximum capacity, Max : From 1kg up to 200,000kg
Verification scale interval : $e = \text{Max} / n$
Maximum number of verification scale intervals: $n = 10000$
(however dependent on environment and the composition
of the modules).
Variants of modules and conditions for the composition
of the modules are set out in the annex

DELTA
Danish Electronics,
Light & Acoustics

Venlighedsvej 4
2970 Hørsholm
Denmark

Tel. (+45) 72 19 40 00
Fax (+45) 72 19 40 01
www.delta.dk
VAT No. DK 12275110

The conformity with the essential requirements in annex 1 of the Directive is met by the application of the European Standard EN 45501: 1992.

The principal characteristics and approval conditions are set out in the descriptive annex to this certificate.

The annex comprises 34 pages.

Issued on 2005-01-28
Valid until 2015-01-28

Signatory: J. Hovgård



Descriptive annex

Contents		Page
1.	Name and type of instrument and modules	2
2.	Description of the construction and function	2
2.1	Construction	2
2.2	Function	4
3.	Technical data	8
3.1	Indicator	8
3.2	Connecting cable between the indicator and the junction box for load cells	8
3.3	Load cells	9
3.4	Load receptors	9
4.	Interfaces and peripheral equipment	9
4.1	Interfaces	9
4.2	Peripheral equipment	10
5.	Approval conditions	10
5.1	Operational modes not approved	10
5.2	Retaining of tally roll records	10
5.3	Compatibility of modules	10
6.	Special conditions for verification	11
6.1	Removable Platforms	11
6.2	Composition of modules	11
7.	Securing and location of seals and verification marks	11
7.1	Securing and sealing	11
7.2	Verification marks	12
8.	Location of CE mark of conformity and inscriptions	12
8.1	Indicator	12
8.2	Load receptors	12
9.	Pictures	14
10.	Compatibility of modules - illustrated	34

1. Name and type of instrument and modules

The weighing instrument is designated FLINTAB type 5204 or 5206 or 5208 or 5218 or 5250 or 5290 or DJB or DWI or RDT52A/B which is a system of modules consisting of an electronic indicator, connected to one or two separate load receptor(s) and peripheral equipment such as printers or other devices, as appropriate.

The instrument is a Class III, self-indicating weighing instrument with single-interval, multi-interval or multi-range.

The modules are listed in sections 3.1 to 3.4.

2. Description of the construction and function

2.1 Construction

2.1.1 Indicator

Each indicator forms part of a comprehensive family FLINTAB 5200 series, which covers various variants as described below. The indicator is specified in section 3.1.

Variants of enclosures

The indicator is available in different variants of enclosures made from either stainless steel, aluminium or plastic.

- Stainless steel box: The display and keyboard is mounted in the front lid. The rear panel contains cable glands for connecting load cells and peripherals etc.
See Figures 1, 3, 5, 6, 9, 17.
- Aluminium / plastic box: The display and keyboard is mounted in the front lid. The back side contains connectors for power, load cells, peripherals etc.
See Figures 2, 4, 7, 8, 10, 18.
- Panel mount.
See Figures 8, 10, 18.

The front panel is available in variants of displays and keyboards.

- Variant 5204:
A LED weight display of 6 digits, 7-segments, 20 mm high, with 2 LED annunciators to indicate kg or pieces and 6 LED annunciators to indicate no-motion, center of zero, Tare in use, Net, Scale platform 1 or Scale platform 2 or the sum of platforms 1+2 is displayed. The keyboard is of the flat membrane type with 8 keys.
See Figures 1, 2.
- Variant 5206:
A LCD weight display of 6 digits, 7-segments, 15/16 mm high, with annunciators to indicate kg, no-motion, battery low, center of zero, Tare in use, Net. The keyboard is of the flat membrane type with 8 keys.
See Figures 3, 4.

- Variant 5208:
A LED weight display of 6 digits, 7-segments, 10 mm high, with LED annunciators to indicate no-motion, center of zero, Tare in use, Net.
The keyboard is of the flat membrane type with 6 keys.
See Figure 5.
- Variant 5218:
A LCD character weight display of 6 digits, 14 mm high, with annunciators to indicate kg or pieces, no-motion, center of zero, Tare in use, Net, Scale platform 1 or Scale platform 2 or the sum of platforms 1+2 is displayed.
The keyboard is of the flat membrane type with 27 keys.
See Figures 6, 7.
- Variant 5250:
A LED weight display of 6 digits, 7-segments, 14 mm high, with LED annunciators to indicate No-motion, Tare in use, Net, Scale platform 1 or Scale platform 2 or the sum of platforms 1+2 is displayed.
The keyboard, 6 keys, is of the flat membrane type with tactile feedback.
See Figure 8.
- Variant 5290:
A LED weight display of 9 digits, (7-segments, 10 mm high, with LED annunciators to indicate No-motion, Center of zero, Tare in use, Net, Rate, Scale platform 1 or Scale platform 2 or the sum of platforms 1+2 is displayed) and a 2-lines by 40 character information /dialogue display.
The keyboard, 33 keys, is of the flat membrane type with accoustic feedback..
See Figures 9, 10.
- Variant RDT52A/B:
A LED weight display of 6 digits, 7-segments, 14 mm high, with LED annunciators to indicate No-motion, Tare in use, Net, Scale platform 1 or Scale platform 2 or the sum of platforms 1+2 is displayed.
The keyboard, 6 keys, is of the flat membrane type with tactile feedback.
See Figures 17, 18.

2.1.2 Weighing interfaces

- Variant DJB (Digital Junction Box):
A non self indicating 4 loadcell summing box and weighing interface in a stainless steel or a plastic box. It contains all transducer electronics to excite the strain gauges, amplify, filter and convert the analogue signal of each load cell to a digital form. Signals from the four inputs are combined to produce a corrected and adjusted weight value. It incorporates high performance A/D conversion including digital calibration with individual DIGITAL CORNER ADJUSTMENT.
See Figures 11, 12, 13, 14.

- Variant DWI (Digital Weighing Interface):
A non self indicating loadcell weighing interface in a stainless steel or a plastic box. It contains all transducer electronics to excite the strain gauge, amplify, filter and convert the analogue signal of the loadcells to a digital form. Two signal inputs are provided which can be used as two independent weigh scales in DUAL channel mode.
See Figures 15, 16.

Electronics

The standard instrument contains the following:

- a main board circuit with digital circuit, EPROM instruction memory, RAM data memory with battery backup, Real Time Clock, serial EEPROM for storage of configuration and calibration parameters, an analog loadcell signal processing circuit enclosed in an EMC shielding box and interface circuits for serial and parallel input/output.
- a display and keyboard interface board, LED or LCD type, with annunciators for center of zero, no-motion, net, memory in use, test procedure, out of range etc. The keyboards are of the flat membrane type with tactile feedback.
- an optional parallel interface for printers
- an optional serial (RS232 or 20mA loop or RS485A) communication interface
- an optional setpoint interface
- an optional digital input/output board
- an optional analog output board
- an optional analog loadcell input board
- - an optional Alibi (electronic tally roll) flash memory (see section 2.2.11)
- - an optional power supply board with 230VAC transformer.

2.1.3 Load cells

Set out in section 3.3.

2.1.4 Load receptors

Set out in section 3.4.

2.1.5 Interfaces and peripheral equipment

Set out in section 4.

2.2 Function

The FLINTAB 5200 series weight indicating instrument is a microprocessor based electronic weight indicator that requires the external connection of strain gauge load cells. The weight information appears in the digital display located on the front panel and may be transmitted to peripheral equipment for recording, data processing or displaying.

The indicator is equipped with a keyboard allowing e.g. zeroing the weight display, taring, initiating a print command and the configuration/calibration of the instrument.

The weight information and all the data typed by the user (codes, names, time and date etc.) can be transmitted to peripherals connected to the instrument.

All the types of the instrument can be connected to peripherals such as computer systems, PCs, printers, bar codes, etc.

All variants of the instrument have same analog circuits.

The primary functions provided are described below.

2.2.1 Power up

On power up the indicator performs an automatic self test and verification of all data storage components to ensure correctness of instruction, calibration and data memory.

During the self test the following are displayed:

- the software program number (refer to the User's manual) for 2 seconds
- the date of issue or the version number (refer to the User's manual) for 2 seconds
- all display segments and annunciators are illuminated for a short period of time and optionally all digits counting up.

In case of error, appropriate error messages are given.

After the test the indicator will proceed with initial zero setting. The message «ZERO» will remain in the primary weight display and/or an error message will be displayed until manual or automatic zero setting is accomplished.

2.2.2 Test function

On power up the indicator will test all memory functions and cause all display elements to illuminate so that a visual verification of their operation can be made.

2.2.3 Displayed range

The indicator displays from -2% of Max to Max+9e.

Under this range, horizontal u line appears on the down part of the display.

Over this range, horizontal inverted u line appears on the upper part of the display.

2.2.4 Zero-setting

Zero setting can only take place when the weight display is stable.

Pressing the ZERO key causes a new zero reference to be established and the ZERO annunciator (>0<) to be illuminated.

Zero-setting range and initial zero setting range are both limited to 4% of Max. from the zero point at the time of calibration.

2.2.5 Zero-tracking

The weight indicator is equipped with a zero-tracking feature which operates over a range of 4% of Max and only when the indicator is at zero and there is no motion in the weight display.

2.2.6 Keyboard functions

According to the software of the instrument the keys have various functions.

All key functions are described in the "Instruction manual" of the different types of indicators.

2.2.7 Tare

The TARE is subtractive ($T = -Max$). Tare operation is possible only if the display is stable and indicates a positive number. Only one active tare is possible at a time. When a tare device is active the annunciator NET is on. The tare value is shown on the display for a brief period of time when the "DISPLAY TARE" key is pressed.

2.2.7.1 Semiautomatic tare

A weighed value is entered as a tare by pressing the "TARE" key, when equilibrium is stable and the indication is positive and within Max. Repeated pressing causes the tare to be cleared and the new tare entered in its place.

2.2.7.2 Preset tare

It is possible to operate different kinds of Preset tare functions.

2.2.7.2.1 Keyboard tare

A keyboard tare may be entered via the "KEYBOARD TARE" key and the numeric keypad. When the keyboard tare is operative no other tare device is active and the net annunciator will be illuminated.

2.2.7.2.2 Fixed tare

Up to 250 (depend on model) preset values associated with a unique identification code can be stored in the indicator. These are entered via the numeric keypad using the "FIXED TARE" program. When the preset tare is operative no other tare device is active and the net annunciator will be illuminated. Preset tares together with their associated identification code may be displayed or printed while the weighing mode is made inactive.

2.2.7.2.3 Product tare

For models 5218 and 5290, up to 99 product associated preset tares can be stored. These are entered via the keypad using the "PRODUCT EDIT" program or from external computer via the serial peripheral interface. The "Product tare" may be entered as a tare upon initiation of a weigh order execution, when no other tare device is active. The net annunciator will be illuminated.

2.2.7.3 Full automatic tare

A full automatic tare device may be switched ON or OFF during the setup, for use in batch recipe weighing only. When the full automatic tare is operative the weighed value is entered as a tare before each weighing. Successive ingredient weighing causes the actual tare to be cleared and the new tare entered in its place.

2.2.7.4 First / second weighing tare

For the types 5218, 5290 there are suitable software with first and second weighing procedures. In these cases the tare is one of the two weighed values (first or second weight) and it is memorized

automatically; the other value is the gross weight. The net weight is calculated automatically from the two values.

2.2.8 Printing

The instrument can be connected to parallel or serial printers with the proper interface. It can be programmed to print G (gross), N (net), T (semi-automatic tare), PT (preset tare), date and time of weighing (first and second weighing), consecutive number of printing, codes, name of the company or any other message that may be required.

Printing is not possible when the indicator is not stable or the display has a negative value.

2.2.9 Setpoints

If the instrument is connected to external devices depending on weight values, the output setpoints can be programmed from the instrument's keyboard to control them.

2.2.10 Analog output

With the optional board installed the indicator gives a current output proportional to the displayed weight in the range of 0-20, or 4-20 mA, or 0-10V.

2.2.11 Alibi memory (flash)

With the option installed the indicator stores weight transactions transmitted to a non-approved peripheral instead of printing the weight. The alibi flash is internal to the instrument and no external access is possible. For each transaction a unique sequential number and the weight and parity are stored in flash memory. The alibi memory may be erased only after printout of its contents. Only gross weights are stored. If the indicator is in net mode an error will be displayed for 2 sec and no alibi storage and no weight transmissions to external equipment will occur. The capacity of the alibi is 9999 records. At each weight transaction the weight will be transmitted to a peripheral only after successful writing to the flash. When the alibi flash is full a warning (Err 55) will be displayed. Operation continues by resetting the unique identification number to 0000. If the memory is found corrupted an error message (Err 57) will be displayed. The information stored in the alibi may be displayed on the primary weight display (PWD) of the indicator or printed using the following functions.

- VIEW of the contents of each record
This is performed by Fn55 (5204, 5206, 5250) or by selecting MENU\MISC\ALIBI\VIEW (5218, 5290).
The PWD shows the last recorded alibi identification number.
Press "PRINT" key to display the corresponding weight or key in the desired identification number and press "PRINT" key to show the weight.
Press "TARE" key to return to identification nr display.
Press "ZERO" key to exit the alibi view function and return to weight display mode.
- Printout of all alibi memory
This is performed by Fn56 (5204, 5206, 5250) or by selecting MENU\MISC\ALIBI\PRINT (5218, 5290). A serial printer must have been connected to the printer port (RS232C) with 80 column paper.

2.2.12 Weight display mode

The indicator may display the weight from scale #1 or scale #2 connected to the analog inputs #1 and #2 respectively. The indicator may also display the sum of the two scales provided that the decimal point and display step of the two scales are the same.

The indication sum 1+2 is the algebraic sum of the two indications.

The displayed range, zeroing range, tare max of each scale are not affected.

Out of range is indicated if any of the two scales is out of range.

The zero and/or tare commands are software ANDed, so if one of the scales can not be zeroed or tared the command is not executed.

If any of the two scales is in motion the zero, tare, print or store commands is inhibited.

Example: $Max_1 = 40.000\text{kg}$ $Max_2 = 40.000\text{kg}$ $Max_{1+2} = 80.000\text{kg}$
 $e_1 = 10\text{kg}$ $e_2 = 10\text{kg}$ $e_{1+2} = 20\text{kg}$

3. Technical data

The weighing instrument is composed of separate modules, which are set out as follows:

3.1 Indicator

The Indicator has the following characteristics:

Accuracy class:	III
Weighing range:	Single-interval, multi-interval or multi-range
Maximum number of Verification Scale Intervals:	10000
Internal resolution:	500000 counts
Fractional factor:	$p'i = 0.5$
Minimum input-voltage per VSI:	0.4 μV
Minimum signal voltage for dead load:	-1.25 to 10 mV
Analog range:	-1.25 to 20 mV
Excitation voltage:	5 VDC switched polarity
Circuit for remote sense: cable	Remote sense using 6-wires in the load cell (5204, 5206, 5218, 5250, 5290, DWI)
Minimum input-impedance:	35 ohm (e.g. 10 load cells of 350 ohm)
Maximum input-impedance:	2000 ohm
Maximum line resistance between indicator and junction box for load cell(s), if any:	5 ohm for each wire
Mains power supply:	220/240VAC, 50/60 Hz adapter (9-15VDC)
Peripheral interface:	Set out in section 4

3.2 Connecting cable between the indicator and the junction box for load cells

3.2.1 6-wire system (5204, 5206, 5218, 5250, 5290, DWI)

Maximum cable length:	300 m / mm ²
Line:	6 wires, shielded

3.2.2 4-wire system (5208, DJB)

Maximum cable length: 12 m
Line: 4 wires, shielded

3.2.3 2-wire RS485 (RDT52A/B)

Maximum length: 1000 m
Line: 2 wires, shielded (digital serial protective interface)

3.3 Load cells

Any load cell(s) may be used for instruments under this certificate of type approval, provided the following conditions are met:

- 1) There is a respective OIML Certificate of Conformity (R60) or a test certificate (EN 45501) issued for the load cell by a Notified Body responsible for type examination under the Directive 90/384/EEC.
- 2) The certificate contains the load cell types and the necessary load cell data required for the manufacturer's declaration of compatibility of modules (WELMEC 2, Issue 4, July 2004, section 11, and any particular installation requirements). A load cell marked NH is allowed only if humidity testing to EN 45501 has been performed.
- 3) The compatibility of load cells and indicator is established by the manufacturer by means of the compatibility of modules form, contained in the above WELMEC 2 document, or the like, at the time of EC verification or declaration of EC conformity of type.
- 4) The load transmission must conform to one of the examples shown in the WELMEC 2.4 Guide for load cells.

3.4 Load receptors

Mechanical mountings are allowed provided that they comply with EN 45501 paragraph 6 or section 3.3. Mechanical platforms are allowed having any size and capacity, and the combined impedance of the load cells is within the range 35 Ohm to 2000 Ohm.

The load receptors may be equipped with appropriate load cells as specified in section 3.3.

Removable platforms shall be equipped with level indicators.

4. Interfaces and peripheral equipment

4.1 Interfaces

As an option, the indicator may be supplied with peripheral interfaces, which allow peripheral equipment to be connected. The peripheral interfaces are positioned on the same side as the load cell interface.

The indicator may have the following optional interfaces.

- Serial Communication ports RS232 C
- Serial Communication ports RS485A
- Serial Communication port 20 mA Current loop

- Parallel Communication port (centronics)
- Digital inputs - outputs (24Vdc, optoisolated)
- Analogue output 0-20 or 4-20mA or 0-10V (galvanically isolated)
- 2nd loadcell analogue input.

The ports are characterised " Protective interfaces" according to paragraph 8.4 in the Directive.

The cables to external equipment must be shielded and having the shields well connected to the cable connector's casing; in case of cable glands the cable shields must be connected to ground just after the cable inlet. The cable connectors must be fixed by screws into screw locks, which are in good contact with the metal cabinet.

4.2 Peripheral equipment

Connection between the weight indicator and peripheral equipment is allowed by screened cable.

The instrument may be supplied with any of the following peripheral equipment:

4.2.1 CITIZEN SWIFT 90 form printer

The CITIZEN SWIFT 90 is a parallel driven form printer equipped with automatic paper out detection which signals an error to the indicator if the printer runs out of paper. The printer has a combined on/off and line feed switch and may be equipped with a real time clock option for printing time and date with each weighing result.

4.2.2 Alternative printers for legal transactions

The instrument may be connected to any simple recipient printer with a CE mark of conformity (see WELMEC 2 issue 4). A printer like this may be used for legal transactions.

5. Approval conditions

5.1 Operational modes not approved

5.1.1 Operation of the instrument in such a way that the instrument becomes an automatic weighing instrument is not covered by this approval.

5.1.2 Piece counting mode is not covered by this approval.

5.2 Retaining of tally roll records

Conditions for retaining of tally roll records as documentation for legal transactions carried out using non-verified peripheral equipment are not covered by this type approval, as no common rule is adopted by the member states as yet. It is up to the national authority to decide on these conditions until a common rule is adopted.

5.3 Compatibility of modules

In case of composition of modules, WELMEC 2 (Issue 4), July 2004, section 11 shall be satisfied.

6. Special conditions for verification

6.1 Removable Platforms

For instruments liable to be tilted, section 3.9.1 of the Standard EN 45501 apply.

6.2 Composition of modules

The environmental conditions should be taken into consideration by the composition of modules for a complete weighing instrument, for example instruments with load receptors placed outdoors and having no special protection against the weather.

The composition of modules shall agree with section 5.2.

An example of a declaration of conformity for the composition of modules is shown in section 10.

7. Securing and location of seals and verification marks

7.1 Securing and sealing

(Refer to the figures 19 and 20)

Seals shall bear the verification mark of a notified body or alternative mark of the manufacturer according to ANNEX II, section 2.3 of the Directive 90/384/EEC.

7.1.1 Indicator

Access to the configuration and calibration facility is achieved by removing the internal calibration jumper "JP1" (located on the main printed circuit board next to the analog circuit) and entering a password. Sealing of the access to the jumper is accomplished with a brittle plastic sticker over one of the screws that keeps the cabinet closed.

Alternatively, the indicator may be sealed by an "Audit Trail" counter which is incremented each time access to the device specific parameters is attempted (see WELMEC 2 point 3.4).

When "JP1" is placed the word "SEALED" will be shown on the display following a software command (DJB, DWI) or by executing Fn 48 (RDT52A/B, 5204, 5206, 5208, 5250) or MENU\MISC\OIML (5218, 5290). Following this the "Audit Trail" counter is displayed. A label with an in-scribed count (all digits permanently printed and pre-end suffixed by a hyphen) is placed on the rear side of the instrument. The label is designated CAL-Nr and may not be removed without destruction.

7.1.2 Indicator - load cell connector - load receptor

Securing of the indicator, load receptor and load cell combined is done by one of the following ways:

- sealing of the load cell connector with the indicator by a lead wire seal or plastic brittle sticker (CALIBRATION VOID IF SEAL BROKEN)
- inserting the serial number of the load receptor as part of the principal inscriptions contained on the indicator identification label
- the load receptor bears the serial number of the indicator on its data plate.

7.1.3 Junction box for load cells

Access to the junction box, if any, is prevented by use of lead seals or by sealing it with brittle plastic stickers.

7.1.4 Peripheral interfaces

All peripheral interfaces are "protective"; they neither allow manipulation with weighing data or Legal Setup, nor change of the performance of the weighing instrument in any way, that would alter the legality of the weighing.

7.2 Verification marks

(Refer to figures 1-18)

7.2.1 Indicator

A green M-sticker and a sticker with verification marks may be placed on the front or top side of the indicator.

7.2.2 Remote display

A remote display shall bear a green M-sticker, if used for trade purposes.

7.2.3 Printers used for legal transactions

Printers covered by this type approval and other printers according to section 4.2 shall bear a green M-sticker, if they are used for legal transactions.

7.2.4 Non-verified peripheral equipment

If such equipment is connected to the weighing instrument, it shall bear a red M-sticker.

8. Location of CE mark of conformity and inscriptions

8.1 Indicator

8.1.1 CE mark

A sticker with the CE mark of conformity and year of production is located at the inscriptions.

8.1.2 Inscriptions

Manufacturers trademark and name and the type designation is located on the front panel.

On a single brittle plastic sticker located on the front panel:

- Max, Min, $e \pm$, accuracy class, serial no., Certificate no., model/type and manufacturer's name.
On a label located on the indicator rear housing or at the mains cable inlet:
- Electrical data

8.2 Load receptors

On a data plate:

- Manufacturers name, type, serial number, capacity.
Left to the manufacturers choice as provided in section 7.1.2:
- Serial no. of the indicator.

9. Pictures

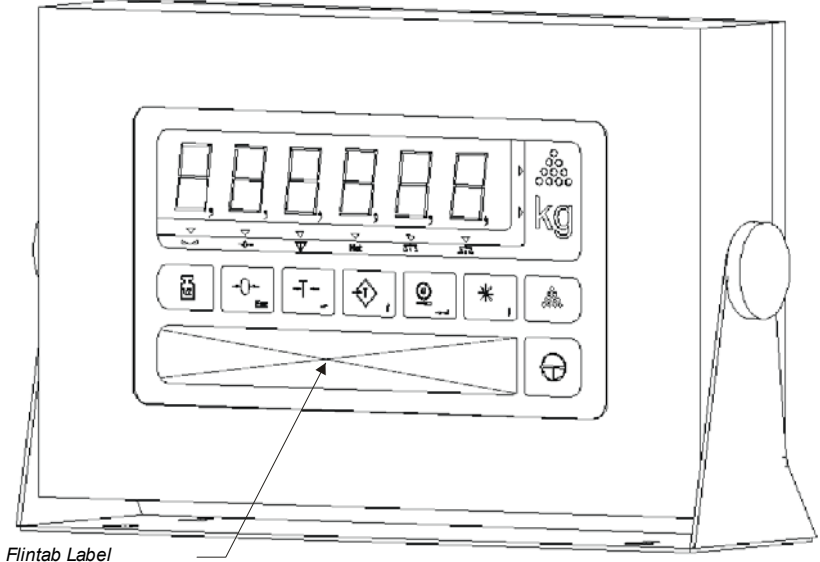

FLINTAB type 5204 Weighing Indicator	Max = 1500 / 3000 kg	DK XXXX.XX
	e = 0,5 / 1 kg	CE III
	Min = 10 kg	
	T = - Max	

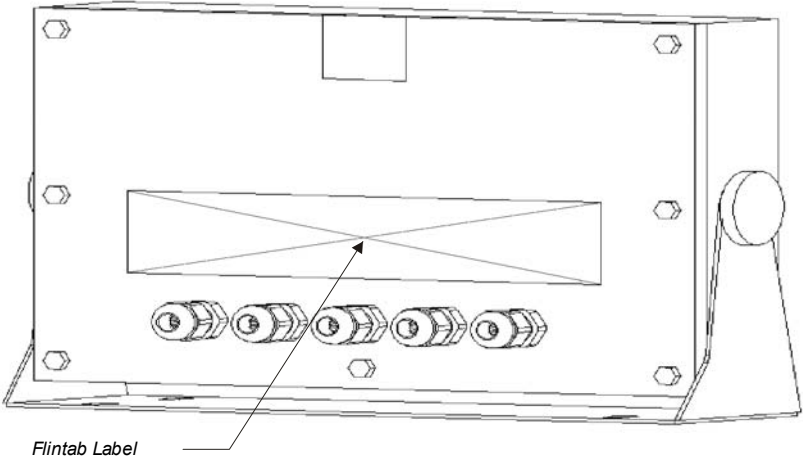

FLINTAB type 5204 Weighing Indicator	Max = 1500 / 3000 kg	DK XXXX.XX		
	e = 0,5 / 1 kg	CE III		
	Min = 10 kg			
	T = - Max S/N 00000001			
J1	J2	J3	J4	J5

Figure 1
 5204 Indicator in stainless steel enclosure

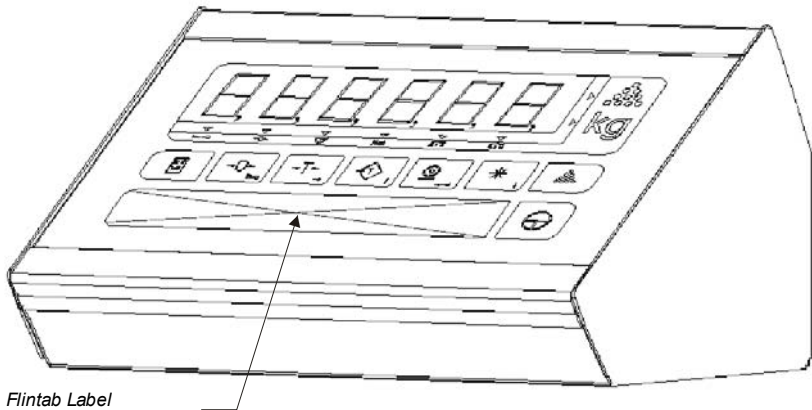

FLINTAB type 5204 Weighing Indicator	Max = 1500 / 3000 kg e = 0,5 / 1 kg Min = 10 kg T = - Max	DK XXXX.XX CE III

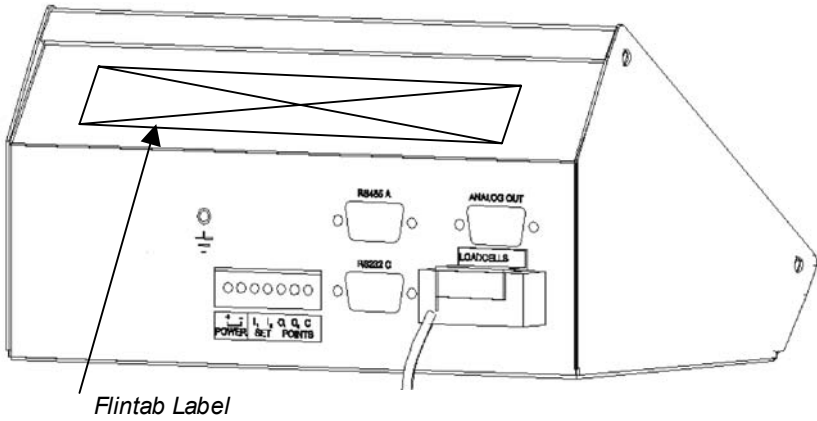

FLINTAB type 5204 Weighing Indicator	Max = 1500 / 3000 kg e = 0,5 / 1 kg Min = 10 kg T = - Max S/N 00000001	DK XXXX.XX CE III

Figure 2
 5204 Indicator in Aluminium/Plastic enclosure

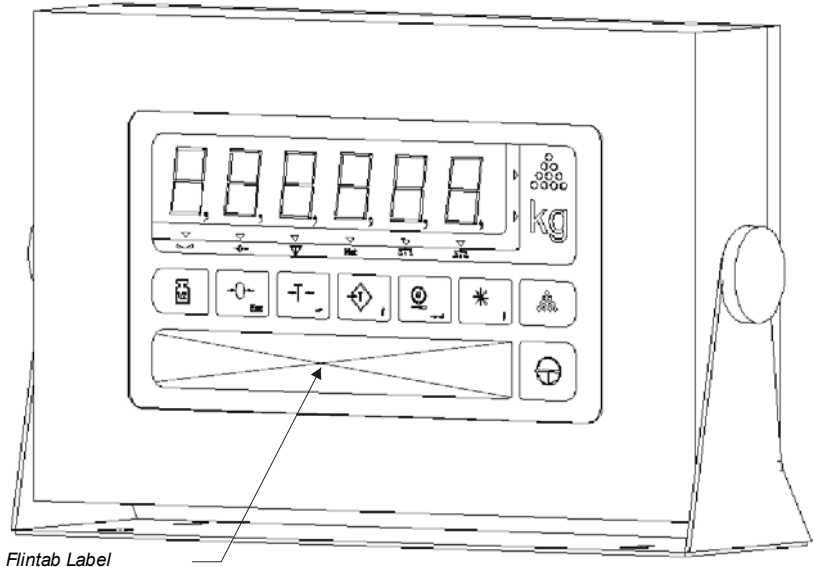

FLINTAB type 5206 Weighing Indicator	Max = 1500 / 3000 kg e = 0,5 / 1 kg Min = 10 kg T = - Max	DK XXXX.XX CE III
--	--	----------------------

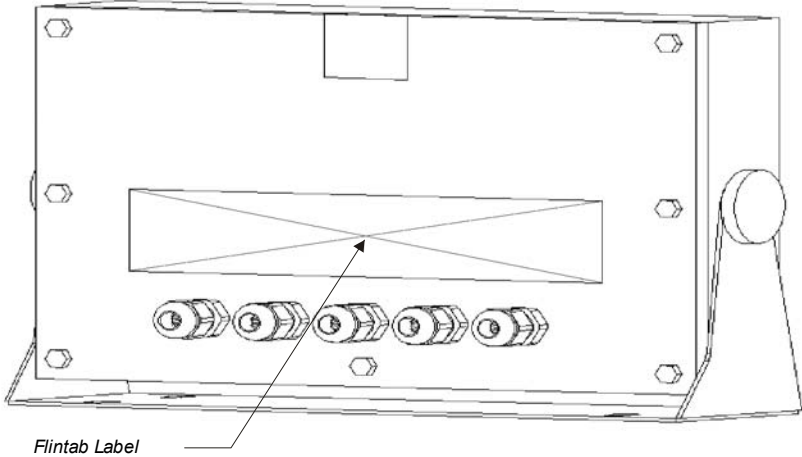

FLINTAB type 5206 Weighing Indicator	Max = 1500 / 3000 kg e = 0,5 / 1 kg Min = 10 kg T = - Max S/N 0000001	DK XXXX.XX CE III				
	<table border="1"> <tr> <td>J1</td> <td>J2</td> <td>J3</td> <td>J4</td> <td>J5</td> </tr> </table>		J1	J2	J3	J4
J1	J2	J3	J4	J5		

Figure 3
 5206 Indicator in stainless steel enclosure

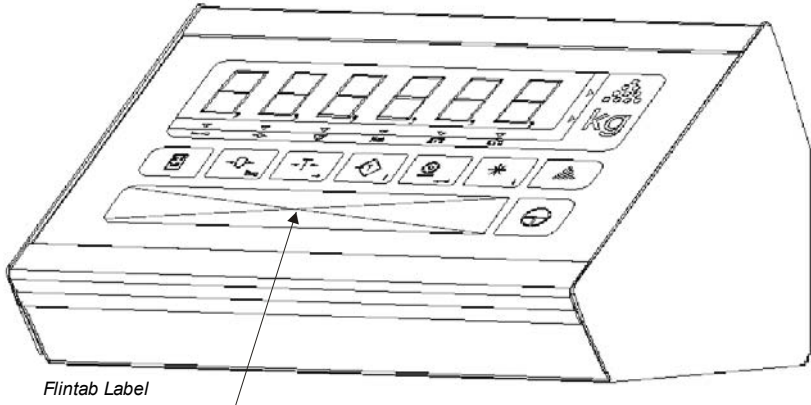

FLINTAB type 5206 Weighing Indicator	Max = 1500 / 3000 kg	DK XXXX.XX
	e = 0,5 / 1 kg	CE III
	Min = 10 kg	
	T = - Max	

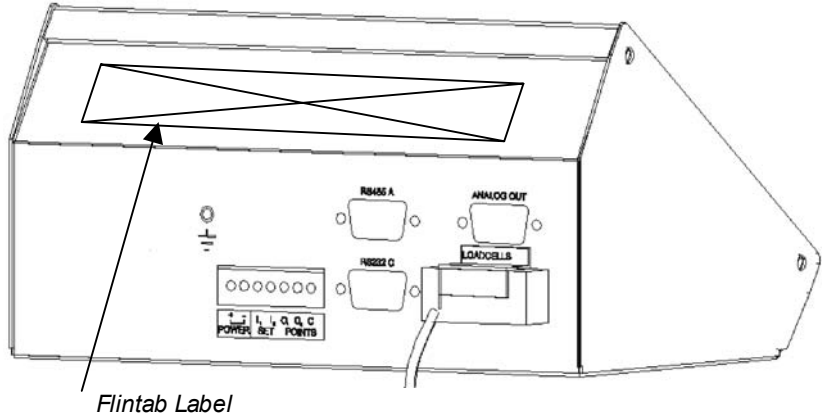

FLINTAB type 5206 Weighing Indicator	Max = 1500 / 3000 kg	DK XXXX.XX
	e = 0,5 / 1 kg	CE III
	Min = 10 kg	
	T = - Max	
	S/N 00000001	

Figure 4
 5206 Indicator in Aluminium/Plastic enclosure

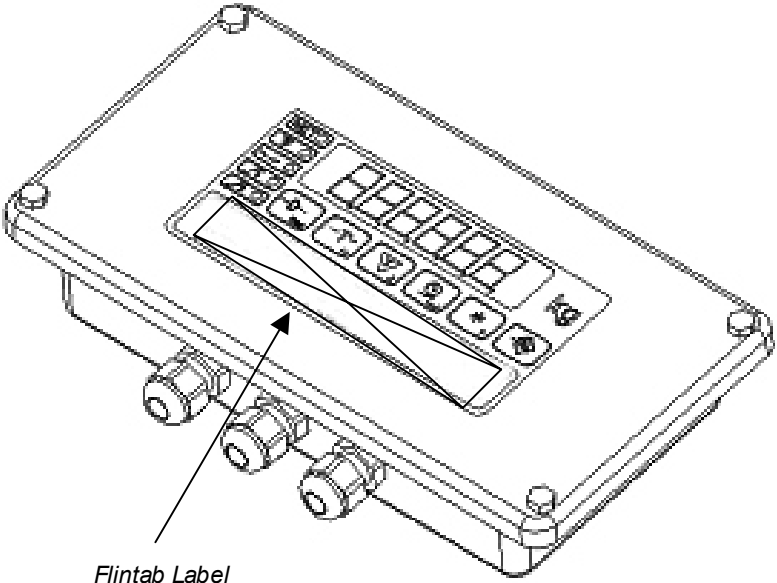

Flintab Label

FLINTAB type 5208 Weighing Indicator	Max = 1500 / 3000 kg	DK XXXX.XX
	e = 0,5 / 1 kg	CE III
	Min = 10 kg	
	T = - Max	

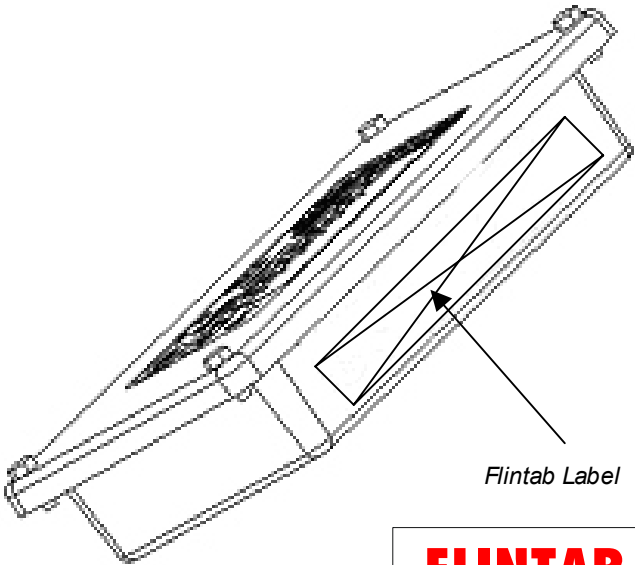

Flintab Label

FLINTAB type 5208 Weighing Indicator	Max = 1500 / 3000 kg	DK XXXX.XX
	e = 0,5 / 1 kg	CE III
	Min = 10 kg	
	T = - Max	
	S/N 00000001	

Figure 5
LD5208 Indicator in stainless steel enclosure

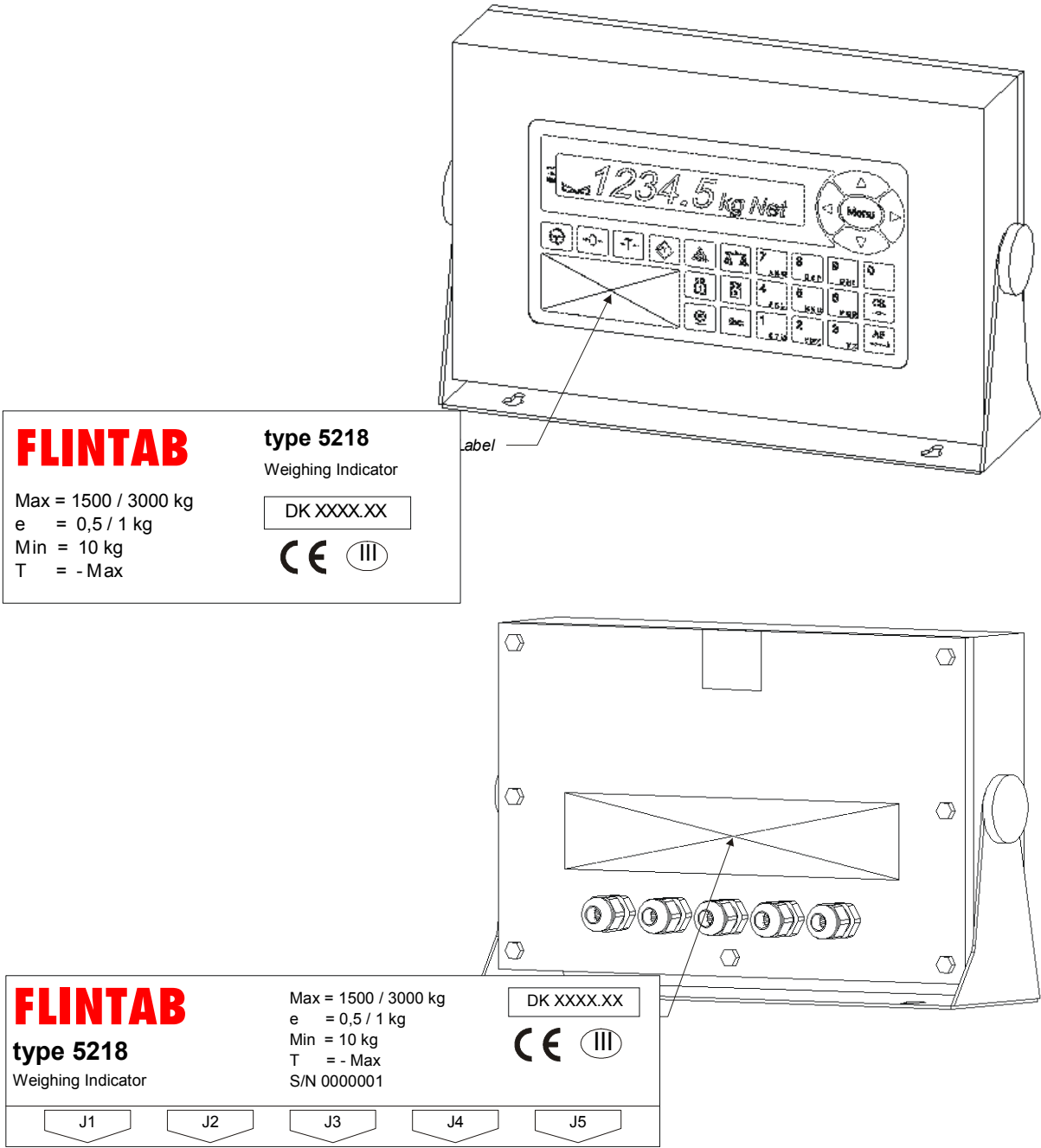

FLINTAB type 5218
 Weighing Indicator

Max = 1500 / 3000 kg
 e = 0,5 / 1 kg
 Min = 10 kg
 T = - Max

DK XXXX.XX

CE III

FLINTAB type 5218
 Weighing Indicator

Max = 1500 / 3000 kg
 e = 0,5 / 1 kg
 Min = 10 kg
 T = - Max
 S/N 0000001

DK XXXX.XX

CE III

J1 J2 J3 J4 J5

Figure 6
 5218 Indicator in stainless steel enclosure

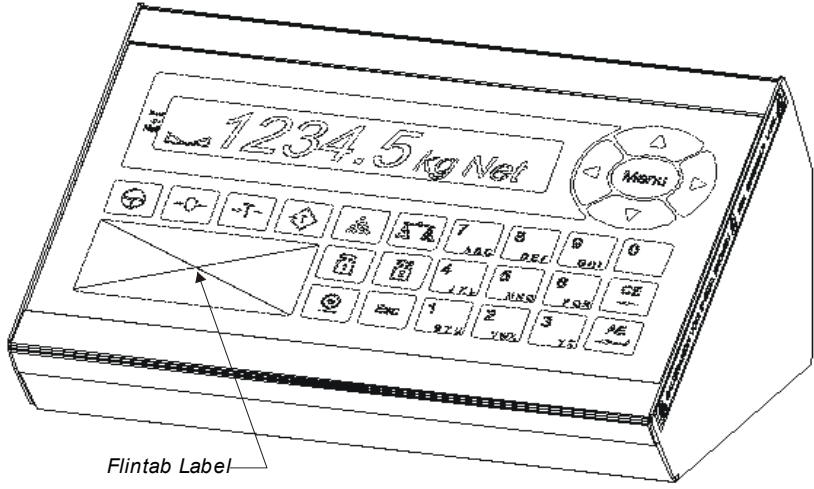

FLINTAB	type 5218
	Weighing Indicator
	DK XXXX.XX
	CE III
	Max = 1500 / 3000 kg e = 0,5 / 1 kg Min = 10 kg T = - Max

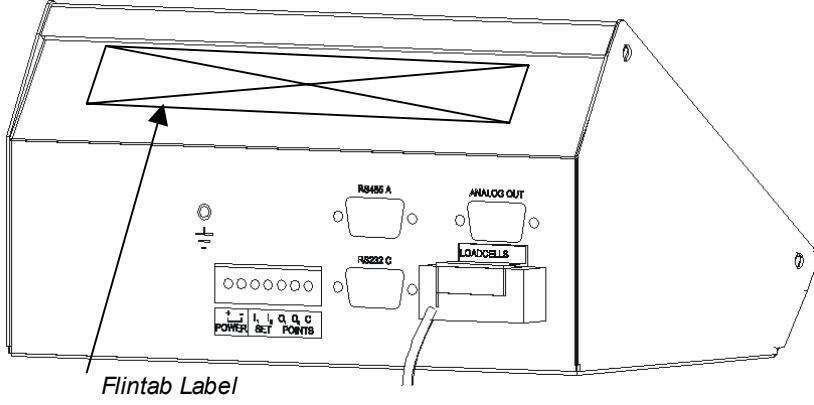

FLINTAB	Max = 1500 / 3000 kg	DK XXXX.XX
	e = 0,5 / 1 kg	
	Min = 10 kg	
	T = - Max	
	S/N 00000001	
type 5218	CE III	
Weighing Indicator		

Figure 7
 5218 Indicator in Aluminium/Plastic enclosure

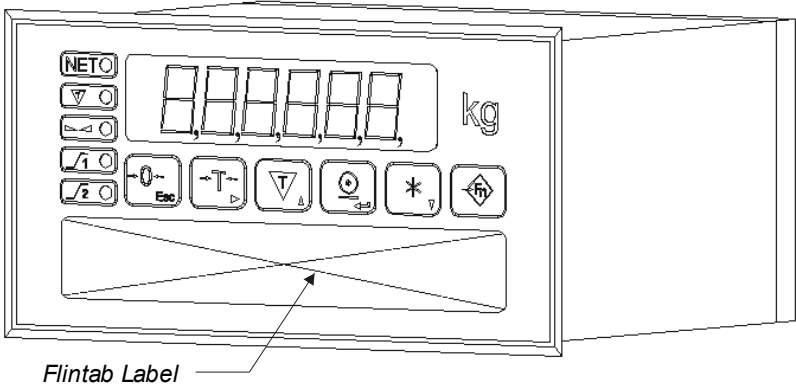

FLINTAB type 5250 Weighing Indicator	Max = 1500 / 3000 kg e = 0,5 / 1 kg Min = 10 kg T = - Max	DK XXXX.XX CE III
	(Empty space for label placement)	

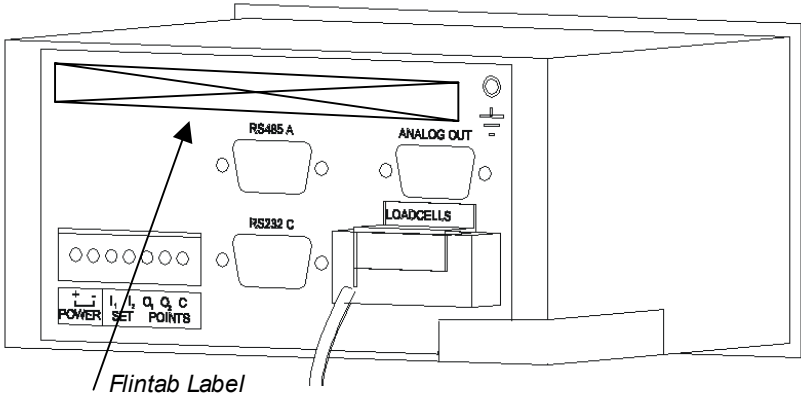

FLINTAB type 5250 Weighing Indicator	Max = 1500 / 3000 kg e = 0,5 / 1 kg Min = 10 kg T = - Max S/N 00000001	DK XXXX.XX CE III
	(Empty space for label placement)	

Figure 8
 5250 Indicator in panel mount enclosure

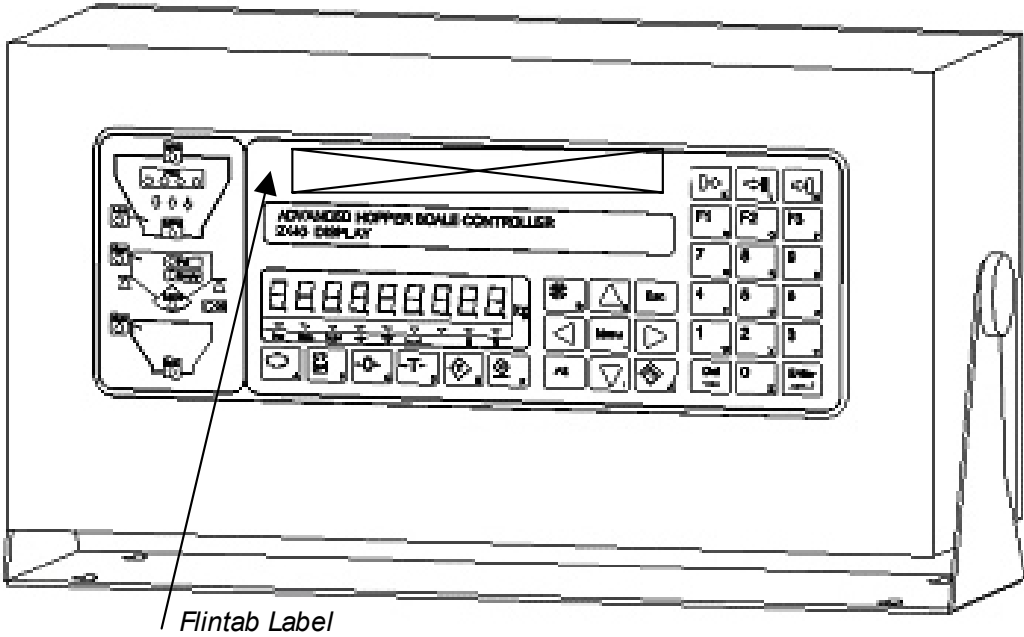

FLINTAB	type 5290	Max = 1500 / 3000 kg	Min = 10 kg	DK XXXX.XX
	Weighing Indicator	e = 0,5 / 1 kg	T = - Max	

CE III

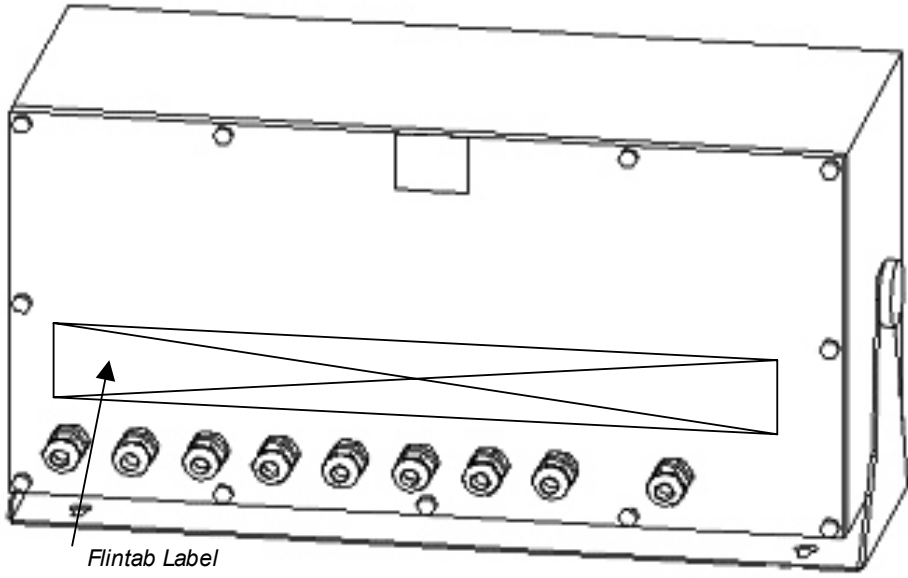

FLINTAB	type 5290	Max = 1500 / 3000 kg	Min = 10 kg	DK XXXX.XX
	Weighing Indicator	e = 0,5 / 1 kg	T = - Max S/N 000001	

CE III

J9
J8
J7
J6
J5
J4
J3
J2
J1

Figure 9
 5290 Indicator in stainless steel enclosure

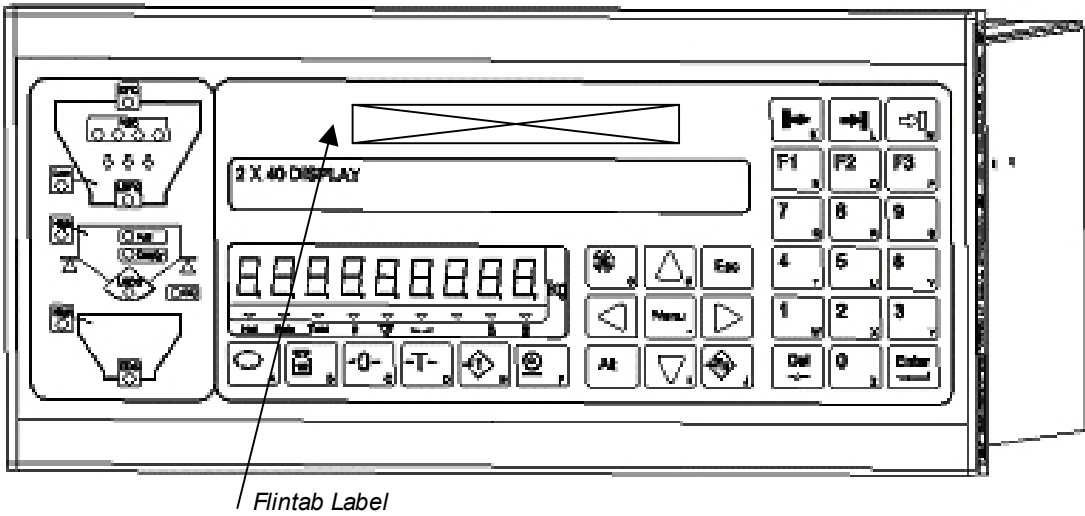

FLINTAB	type 5290	Max = 1500 / 3000 kg	Min = 10 kg	DK XXXX.XX
	Weighing Indicator	e = 0,5 / 1 kg	T = - Max	

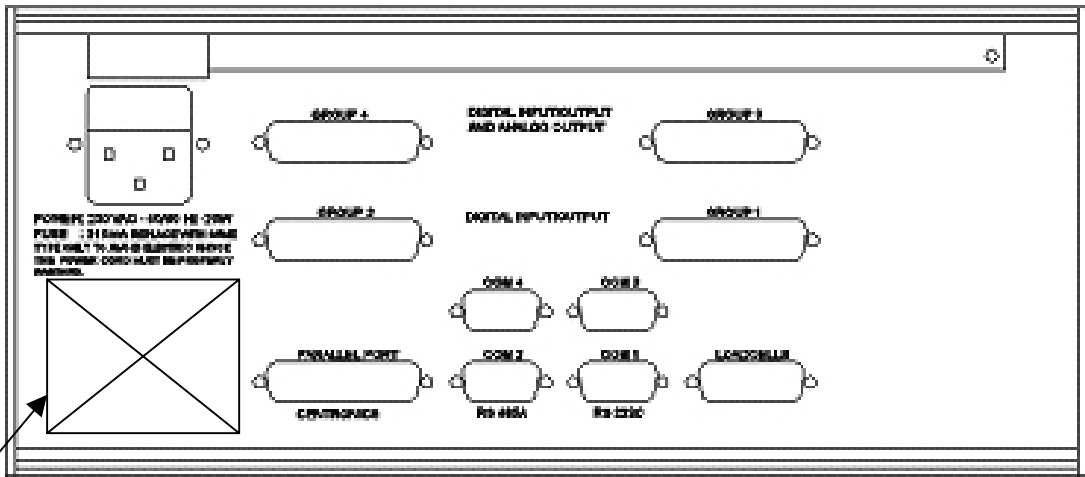

Flintab Label

Figure 10
 5290 Indicator in panel mount metal enclosure

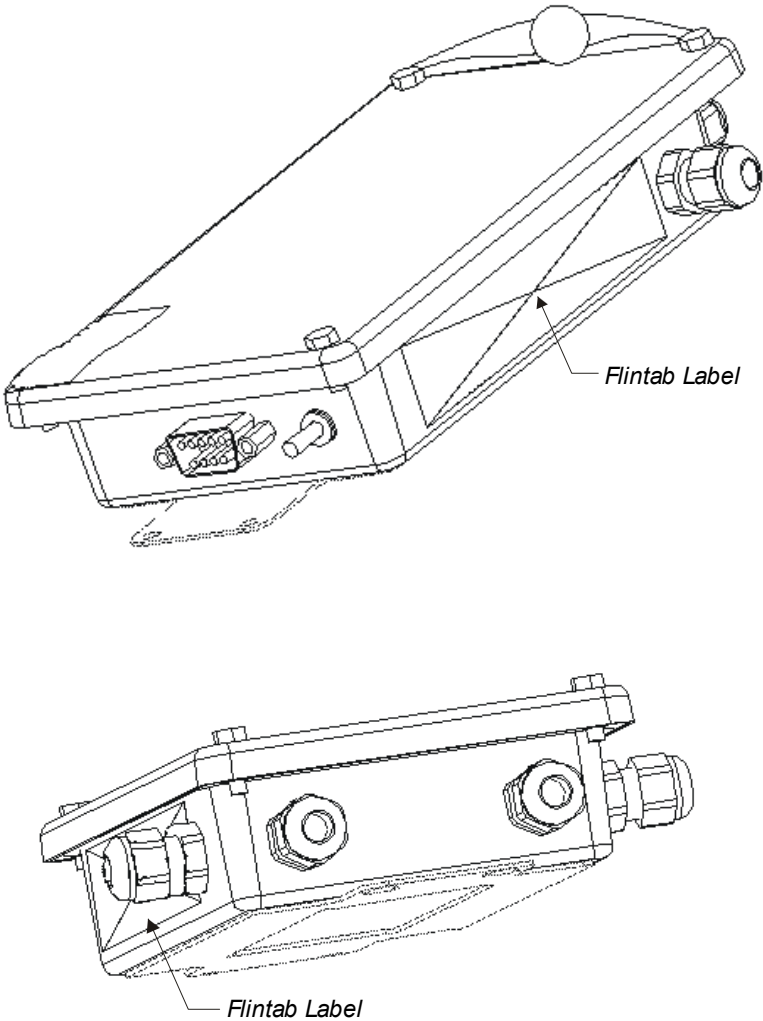

FLINTAB type DJB A/D Converter	Max = 1500 / 3000 kg	DK XXXX.XX
	e = 0,5 / 1 kg	
	Min = 10 kg	CE III
	T = - Max	
	S/N 00000001	

Figure 11
DJB A/D Converter in stainless steel/plastic enclosure (PG9+DB9 connector)

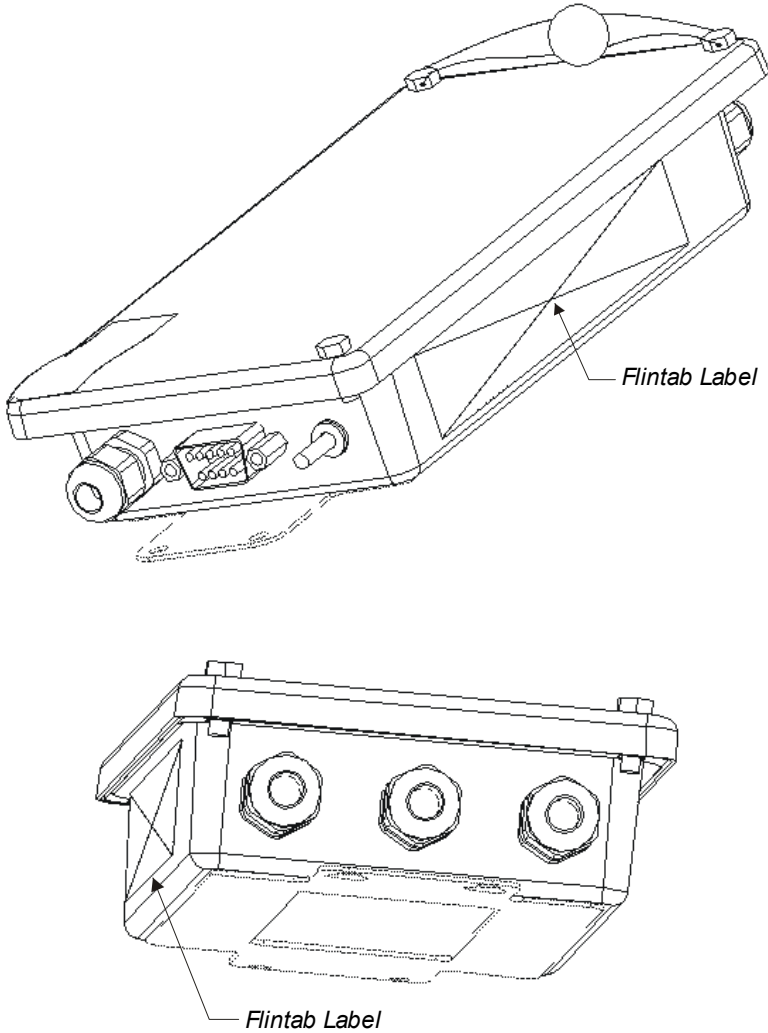

FLINTAB type DJB A/D Converter	Max = 1500 / 3000 kg	DK XXXX.XX
	e = 0,5 / 1 kg	
	Min = 10 kg	CE III
	T = - Max	
	S/N 00000001	

Figure 12
DJB A/D Converter in stainless steel/plastic enclosure (PG9+DB9 connector)

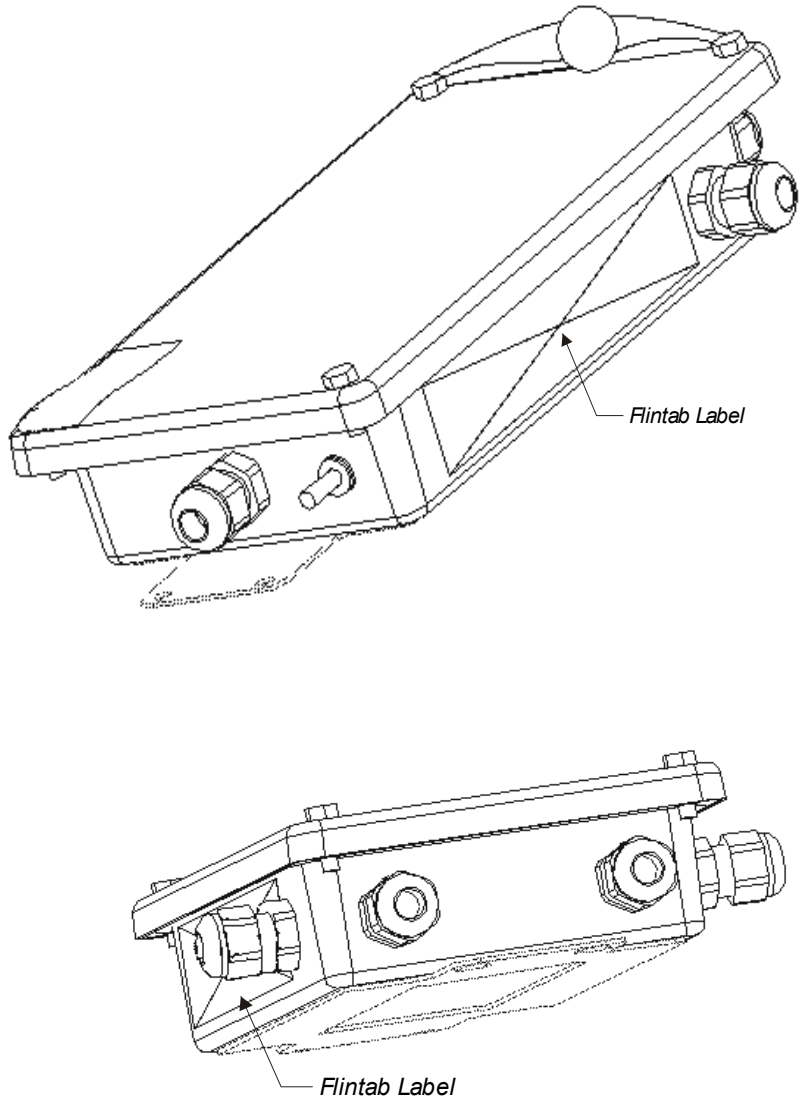

FLINTAB type DJB A/D Converter	Max = 1500 / 3000 kg	DK XXXX.XX
	e = 0,5 / 1 kg	
	Min = 10 kg	
	T = - Max	
	S/N 00000001	CE III

Figure 13
DJB A/D Converter in stainless steel/plastic enclosure (all PG9 cable glands)

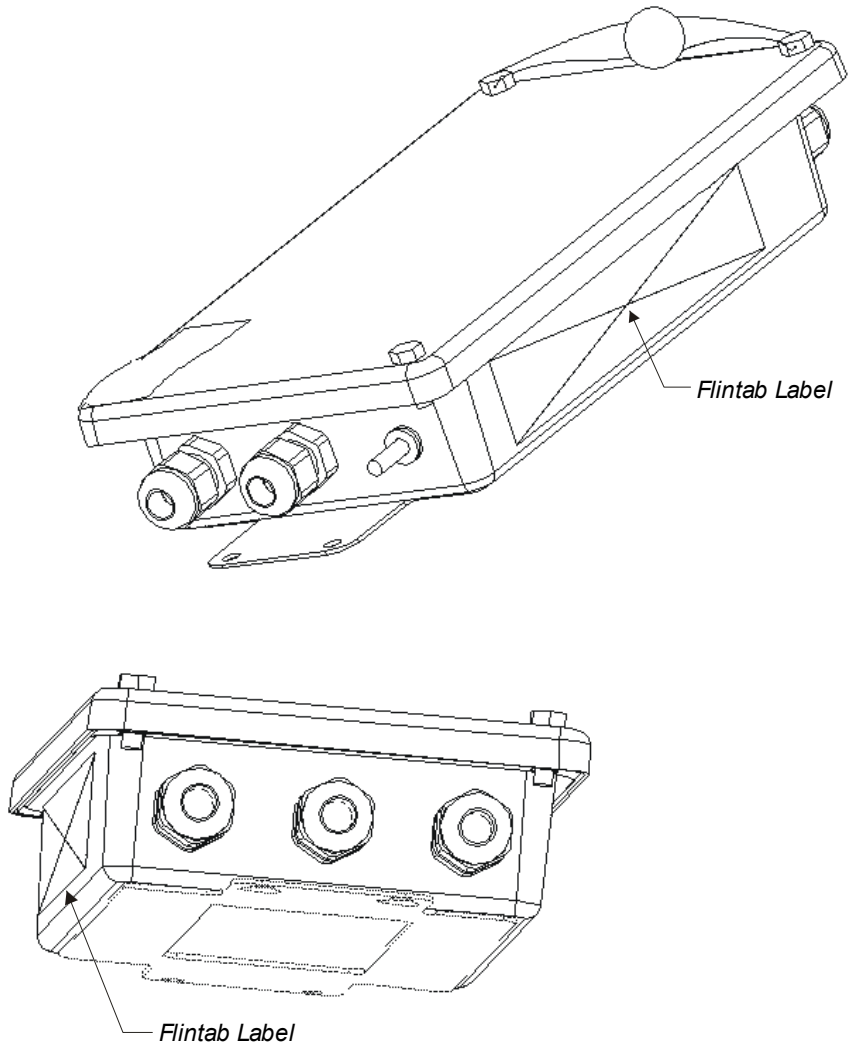

FLINTAB type DJB A/D Converter	Max = 1500 / 3000 kg	DK XXXX.XX
	e = 0,5 / 1 kg	
	Min = 10 kg	CE III
	T = - Max	
S/N 00000001		

Figure 14
DJB A/D Converter in stainless steel/plastic enclosure (all PG9 cable glands)

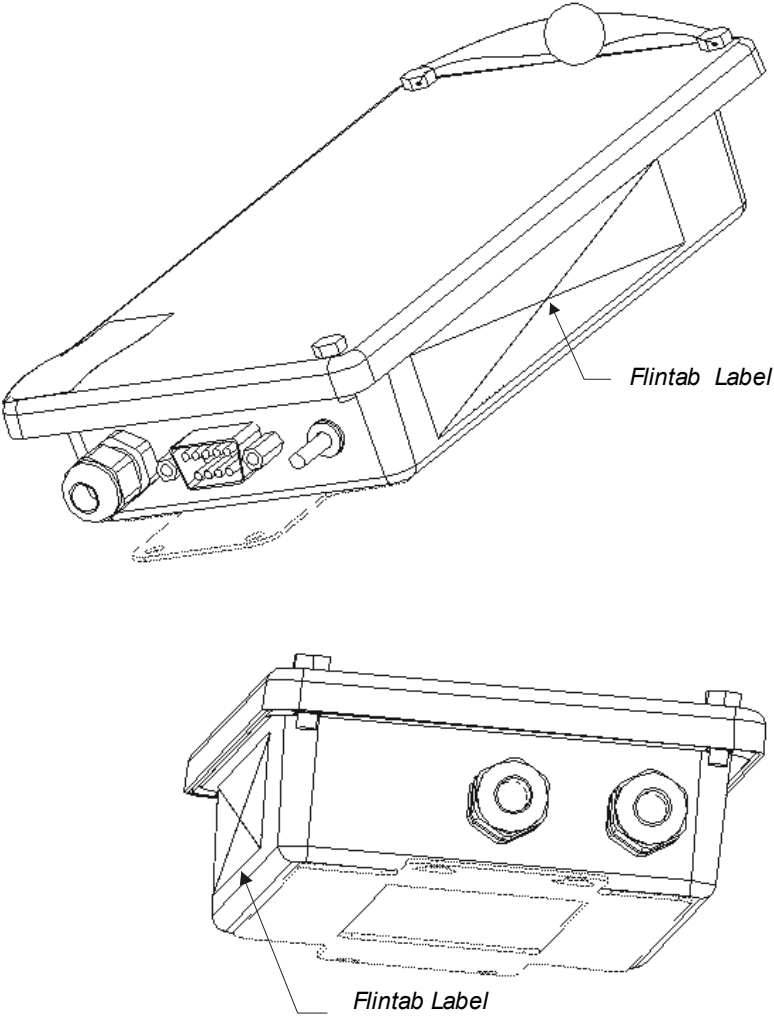

FLINTAB type DWI A/D Converter	Max = 1500 / 3000 kg	DK XXXX.XX
	e = 0,5 / 1 kg	
	Min = 10 kg	CE III
	T = - Max	
S/N 00000001		

Figure 15
DWI A/D Converter in stainless steel/plastic enclosure (PG9+DB9 connector)

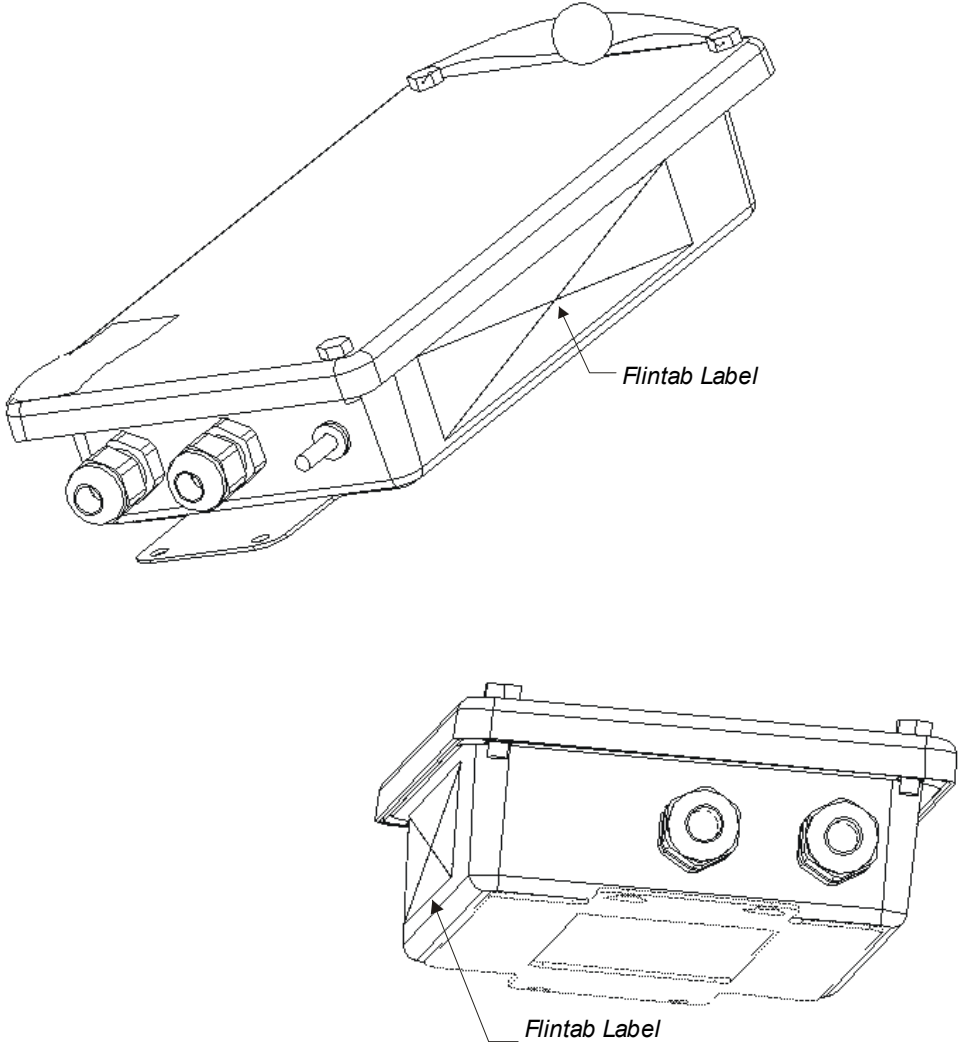

FLINTAB type DWI A/D Converter	Max = 1500 / 3000 kg	DK XXXX.XX
	e = 0,5 / 1 kg	
	Min = 10 kg	CE III
	T = - Max	
S/N 00000001		

Figure 16
DWI A/D Converter in stainless steel/plastic enclosure (all PG9 cable glands)

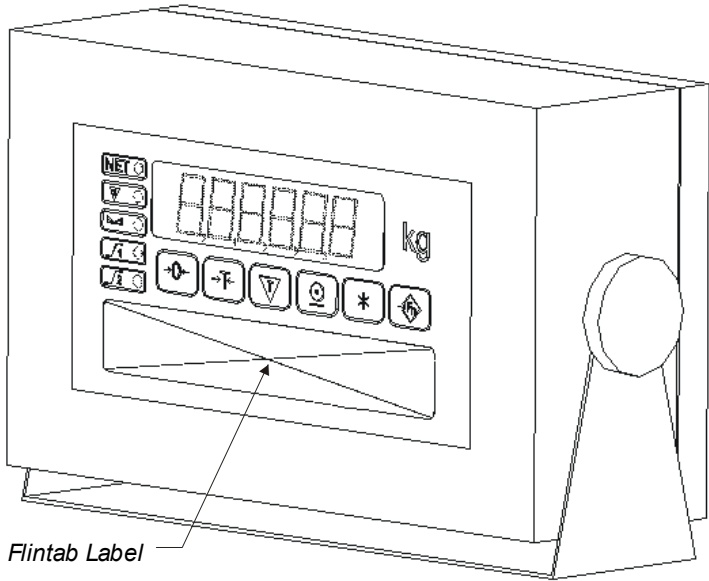

FLINTAB type RDT52A/B Display Terminal	Max = 1500 / 3000 kg e = 0,5 / 1 kg Min = 10 kg T = - Max	DK XXXX.XX CE III
	(Empty space for label content)	

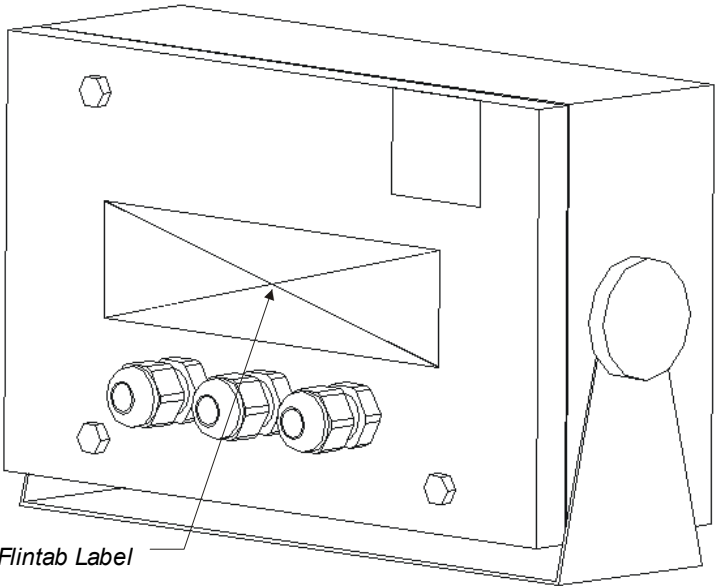

FLINTAB type RDT52A/B Display Terminal	Max = 1500 / 3000 kg e = 0,5 / 1 kg Min = 10 kg T = - Max S/N 0000001	DK XXXX.XX CE III
	(Empty space for label content)	
J3 J2 J1		

Figure 17
 RDT52A/B Display Terminal in stainless steel enclosure

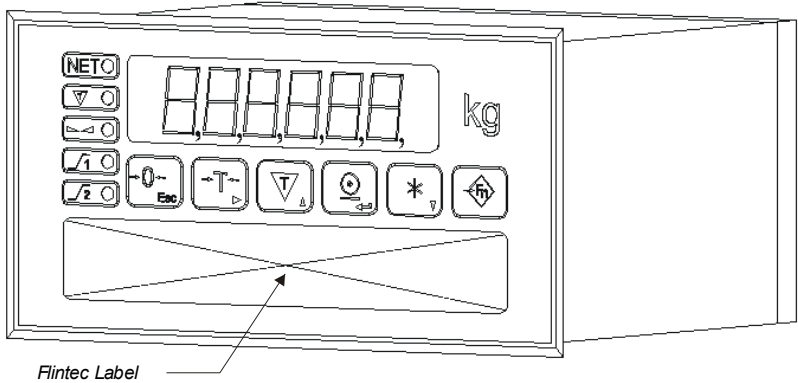

FLINTAB type RDT52A/B Display Terminal	Max = 1500 / 3000 kg	DK XXXX.XX
	e = 0,5 / 1 kg	CE III
	Min = 10 kg	
	T = - Max	

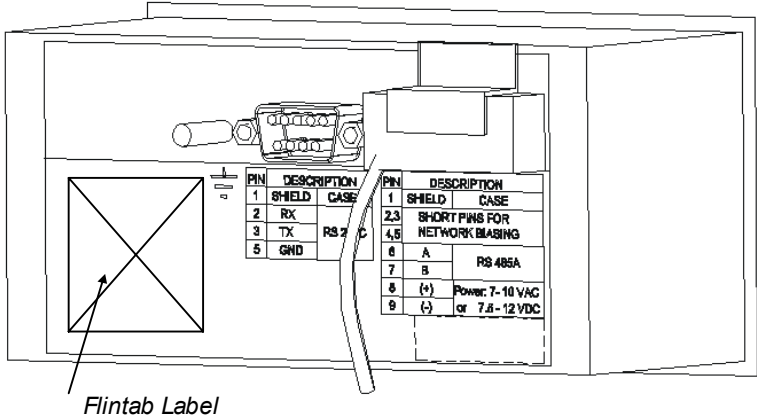

FLINTAB	type RDT52A/B
	Display Terminal
Max = 1500 / 3000 kg	DK XXXX.XX
e = 0,5 / 1 kg	CE III
Min = 10 kg	S/N 00000001
T = - Max	

Figure 18
 RDT52A/B Display Terminal in panel mount plastic enclosure

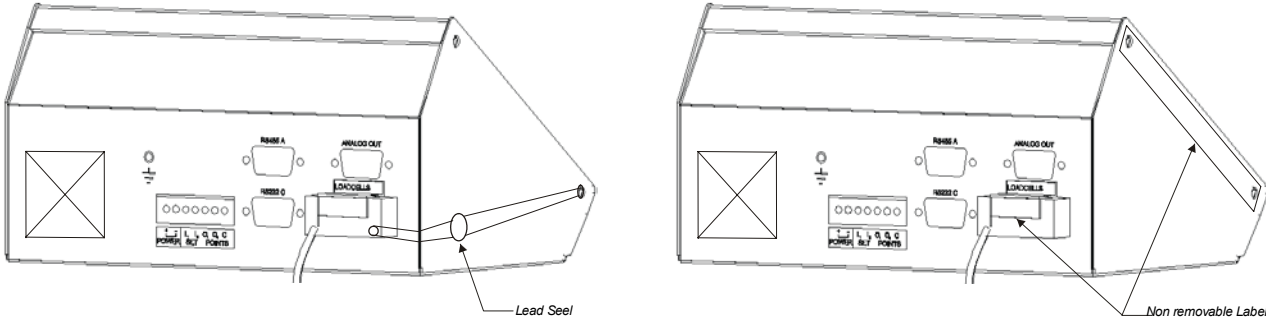

ALUMINIUM / PLASTIC ENCLOSURE

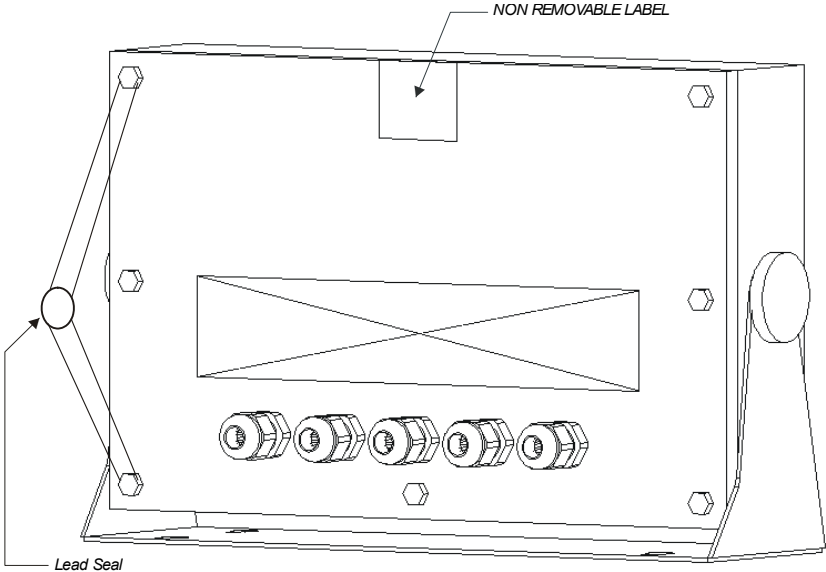

STAINLESS STEEL ENCLOSURE



Figure 19
5200 Family sealing details

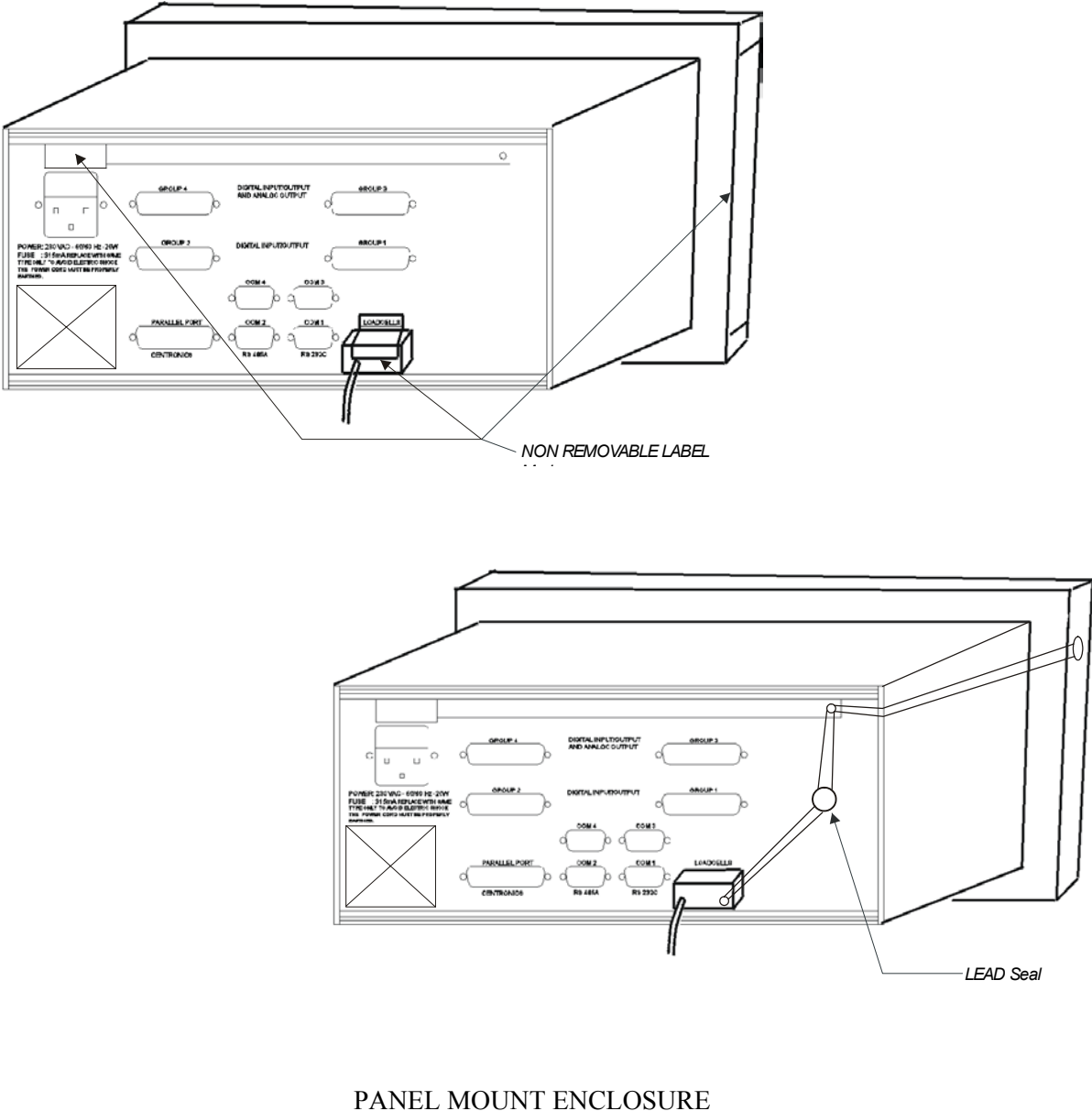

Figure 20
5200 Family sealing details

10. Compatibility of modules - illustrated

COMPATIBILITY OF MODULES		TAC: DK 0199.65	
Ref.: WELMEC 2			
Non-Automatic Weighing Instrument, single-interval.			
Certificate of EU Type-Approval N°:		TAC: DK 0199.65	
INDICATOR	A/D (Module 1)	Type: FLINTAB S.R.L.	5290
Accuracy class according to EN 45501 and OIML R76:		Class _{ind} (I, II, III or IIII)	III
Maximum number of verification scale intervals (n _{max}):		n _{ind}	10000
Fraction of maximum permissible error (mpe):		p ₁	0.5
Load cell excitation voltage:		U _{exc} [Vdc]	5
Minimum input-voltage per verification scale interval:		ΔU _{min} [μV]	0.4
Minimum load cell impedance:		R _{Lmin} [Ω]	35
Coefficient of temperature of the span error:		E _s [% / 25°C]	
Coefficient of resistance for the wires in the J-box cable:		S _X [% / Ω]	
Specific J-box cable-length to the junction box for load cells:		(L/A) _{max} [m / mm²]	300
Load cell Interface:		6-wire (remote sense)	
Additive tare, if available:		T* [% of Max]	0
Initial zero setting range:		IZSR [% of Max]	-2 / 2
Temperature range:		T _{min} / T _{max} [°C]	-10 / 40
Test report (TR), Test Certificate (TC) or OIML Certificate of Conformity:		TC: DELTA	DANAK-194883
LOAD RECEPTOR	(Module 2)	Type: Platform	
Construction:		Platform	
Fraction of mpe:		p ₂	0.5
Number of load cells:		N	4
Reduction ratio of the load transmitting device:		R = F _M / F ₁	1
Dead load of load receptor:		DL [% of Max]	10
Non uniform distribution of the load:		NUD [% of Max]	0
Correction factor:		Q = 1 + (DL + T* + IZSR* + NUD) / 100	1.12
LOAD CELL	ANALOG (Module 3)	Type: Revere Transducers	5102
Accuracy class according to OIML R60:		Class _{LC} (A, B, C or D)	C
Maximum number of load cell intervals:		n _{LC}	3000
Fraction of mpe:		p ₃	0.7
Rated output (sensitivity):		C [mV / V]	2
Input resistance of single load cell:		R _{LC} [Ω]	350
Minimum load cell verification interval: (V _{min%} = 100 / Y)		V _{min%} [% of E _{max}]	0.01
Rated capacity:		E _{max} [kg]	1134
Minimum dead load, relative:		(E _{min} / E _{max}) * 100 [%]	0
Temperature range:		T _{min} / T _{max} [°C]	-10 / 40
Test report (TR) or Test Certificate (TC/OIML) as appropriate:		NMI	TC2161
COMPLETE WEIGHING INSTRUMENT		Single-interval	
Manufacturer:		Type:	
Accuracy class according to EN 45501 and OIML R76:		Class _{WI} (I, II, III or IIII)	III
Fractions: p ₁ = p ₁ ² + p ₂ ² + p ₃ ² :		p ₁	1.0
Maximum capacity:		Max [kg]	1500
Number of verification scale intervals:		n	3000
Verification scale interval:		e [kg]	0.5
Utilisation ratio of the load cell:		α = (Max / E _{max}) * (R / N)	0.33
Input voltage (from the load cells):		Δ _u = C * U _{exc} * α * 1000 / n [μV/e]	1.10
Cross-section of each wire in the J-box cable:		A [mm²]	0.5
J-box cable-length:		L [m]	150
Temperature range to be marked on the instrument:		T _{min} / T _{max} [°C]	Not required
Peripheral Equipment subject to legal control:			

Acceptance criteria for compatibility		Passed, provided no result below is - 0	
Class _{WI}	≤ Class _{ind} & Class _{LC} (WELMEC 2: 1)	Class _{WI}	PASSED
p ₁	≤ 1 (R76: 3.5.4.1)	1 - p ₁	0.0
n	≤ n _{max} for the class (R76: 3.2)	n _{max} for the class - n	7000
n	≤ n _{ind} (WELMEC 2: 4)	n _{ind} - n	7000
n	≤ n _{LC} (R76: 4.12.2)	n _{LC} - n	0
E _{min}	≤ DL * R / N (WELMEC 2: 6d)	(DL * R / N) - E _{min}	37.5
V _{min} * √N / R	≤ e (R76: 4.12.3)	e - (V _{min} * √N / R)	0.273
or (if V _{min} is not given)		Alternative solution	
(E _{max} / n _{LC}) * (√N / R)	≤ e (WELMEC 2: 7)	e - ((E _{max} / n _{LC}) * (√N / R))	
ΔU _{min}	≤ ΔU (WELMEC 2: 8)	ΔU - ΔU _{min}	0.70
R _{Lmin}	≤ R _{LC} / N (WELMEC 2: 9)	(R _{LC} / N) - R _{Lmin}	53
L / A	≤ (L / A) _{max} ^{WI} (WELMEC 2: 10)	(L / A) _{max} ^{WI} - (L / A)	0
T _{range}	≤ T _{max} - T _{min} (R76: 3.9.2.2)	(T _{max} - T _{min}) - T _{range}	20
Q * Max * R / N	≤ E _{max} (R76: 4.12.1)	E _{max} - (Q * Max * R / N)	714.0

Signature and date: _____ Conclusion PASSED

This is an authentic document made from the program:
"Compatibility of NAWI-modules version 3.2".