



INSTALLATION AND SAFETY MANUAL

For Tigo Energy® Module Maximizer™ (MM-ES) and (MM-2ES)



Manual version 2.2 Dated 02/20/2012

Applies to the following:

All Tigo Energy Module Maximizers series (MM-ES)

Tigo Energy® Maximizer™ Management Unit (MMU)

Tigo Energy® Gateway (GTWY)

TABLE OF CONTENTS:

Safety Instructions.....	4
Identifying Parts of the Module Maximizer System.....	6
Configure the System Before Going to the Site.....	7
Install the Management Unit and Gateway.....	12
Install the Maximizers and Verify System.....	17
Troubleshooting.....	25
Warranty Information.....	29
Technical Specifications.....	32

This is manual version 2.2 Dated 02/20/2012

Please check: <https://datacenter.tigoenergy.com/main/installations.php> to make sure you have the most up-to-date version.

PRODUCT SYMBOLS



Failure to follow instructions may result in serious hardware failure, injury, or death.
Use extreme caution when performing this task.



Low Voltage Directive 2006/95/EEC



UL 1741 Safety Standards for Distributed Generation

Easy three step installation:

1



Configure the system before going to the site, section 1

2



Install the Management Unit and Gateway, section 2

3



Install the Maximizers and verify system, section 3

PLEASE READ THIS FIRST:

IMPORTANT SAFETY INSTRUCTIONS SAVE THESE INSTRUCTIONS



This manual contains important instructions for installation and maintenance of the Tigo Energy® product models MM-ES050V300W, MM-ES075V350W, MM-ES110V300W, MM-ES170V300W, MM-2ES050V300W, MU-ESW, and related Tigo Energy software applications.



Risk of electric shock, do not remove cover, disassemble, or repair. No user serviceable parts inside. Refer servicing to qualified service personnel. See warranty in the appendix for instructions on how to obtain service.



Before installing or using the Tigo Energy® Maximizer™ System, please read all instructions and warning markings on the Tigo Energy products, appropriate sections of your inverter manual, photovoltaic (PV) module installation manual, and other available safety guides.



Failure to adhere to these instructions may result in injury or death, damage to the system, and voiding the factory warranty.



To reduce risk of fire and shock hazard, install this device with strict adherence to National Electric Code (NEC) ANSI/NFPA 70 and/or local electrical codes. When the photovoltaic array is exposed to light, it supplies a DC voltage to the Tigo Energy® Module Maximizer™. The Module Maximizer starts in the “on” state and its output voltage may be as high as the PV module open circuit voltage (Voc) when connected to the module. The installer should use the same caution when handling electrical cables from a PV module with or without the Tigo Energy Module Maximizer attached.



Installation must be performed by trained professionals only. Tigo Energy does not assume liability for loss or damage resulting from improper handling, installation, or misuse of products.



Remove all metallic jewelry prior to installing the Tigo Energy Module Maximizer to reduce the risk of contacting live circuitry. Do not attempt to install in inclement weather.



Do not operate the Tigo Energy Module Maximizer if it has been physically damaged. Check existing cables and connectors, ensuring they are in good condition and appropriate in rating. Do not operate the Tigo Energy Module Maximizers with damaged or substandard wiring or connectors. Tigo Energy Module Maximizer should be mounted 3 ft. minimum above ground.



Do not connect or disconnect under load. Turning off the Inverter and/or the Tigo Energy products may not reduce this risk. Internal capacitors within the inverter can remain charged for several minutes after disconnecting all power sources. Verify capacitors have discharged by measuring voltage across inverter terminals prior to disconnecting wiring if service is required.



Service Personnel: Check the voltage of the array after activating the Tigo Energy® PV-Safe™ function on the MMU prior to performing service.



Always assume Maximizer is in on state, or may turn on when restarting.

TIGO ENERGY SUPPORT LINES:

(USA) +1.888.609.TIGO (8446)

(Europe) +800-CALL-TIGO (2255-8446)

skype: support.tigoenergy

BRING TO THE SITE:

Ethernet equipment (cable or other options to connect MMU to local router)



A laptop PC, smart phone, or internet connected device to track completion of each step in the on site installation procedures.



Installation company master user ID/password information if already established.



Installation schematic drawing.



Phillips (#1), slotted screwdrivers, and needle nose pliers.



MC4 connectors (1 male, 1 female per string)



Permanent marker or label maker.



Spool of RS-485 cable, wire stripper, crimping tool and others.



IDENTIFYING PARTS OF THE TIGO ENERGY® MAXIMIZER™ SYSTEM



*Tigo Energy®
Module Maximizer™
(MM-ES or MM-2ES)*



*Tigo Energy® Maximizer™
Management Unit (MMU)*



Gateway



Sensor Box (Optional)

1

Configure the System Before Going to the Site

1.1 SYSTEM CONFIGURATION

To ensure full functionality of the software installation tools (ex. the “Status Page”), the installer must complete this step prior to installing any of the Tigo Maximizer System hardware.



For a first-time installation create a user name and password by going to www.tigoenergy.com and selecting “login” in the upper-right hand corner. From the next page, click on the link that says “New Installer? Sign up.” A new page will appear where a new Tigo Energy Account can be created. Enter all asterisk fields with the appropriate information.

1.1.1 CREATE A NEW USER NAME

Fill in all the fields, and press “Submit” to confirm. An e-mail will be sent to the e-mail address that was entered on the previous page.

Login to e-mail account provided, select the e-mail from Tigo Energy, and click on the link provided in the e-mail to activate the Tigo Energy account. The link will return to the Tigo Energy login page, use the new user name and password to enter the site.



NOTE: The user name and password will become the Installation Company’s master login information that will be used for setting up and configuring all future sites.

Upon entering the “My Installations” page, press the “New Installation” button to create a new site. A 2-step form will request all necessary information about the site. (Fig. 1)



New Installation

1.1.2 ENTER THE SYSTEM CONFIGURATION

Have the 12 digit code from the Management Unit, and all of the Mac IDs from the Maximizers available before starting the system configuration process. Maximizer codes can be found on the outside of the box; this is not recommended if box has been opened. All identification codes are located under the barcode of the unit and can be entered manually or with a barcode scanner.

Enter the Site Name, Installation ID (which can be any number, or can be left blank and will be auto-assigned by Tigo), and 12-digit MMU identification code in the blank fields on this page. Press “Next” to save and continue. (Fig. 1)

Fill out all sections with blank fields:

- Installer Information
- Project Site Information
- System Information
- Press “Finish” to save all information.

A new page will appear stating that the form was finished and saved. Click on “Go to My Installations Page” to configure the new site. On the “My Installations” page, scroll to “pending sites” and press the “Configure” button next to the new site. This will begin the 3-part System Configuration process for the new site. (Fig. 2)

All fields in this section should be auto-populated with information from the “New Site” form. If this is a multi-gateway system, ensure that the field marked “Number of Gateways” displays the correct number of Gateways that are in the system. Once all information has been verified, press “Next” to save and continue. (Fig. 3)

Enter ID codes for all of the Maximizers in the system. This is best done with a handheld barcode scanner. Keep in mind that if a Dual Maximizer (MM-2ES) is scanned, it will populate two slots in the string, to represent the two modules that will be connected to it.

After entering a Maximizer’s ID, make sure to label the unit with the specific designation it was just assigned using a permanent marker (i.e. A1, A2... B1, B2...etc). (Fig. 4)

After saving, a new page will appear. Click “My Installations” to access the newly configured site. Once on the “My Installations” page, select the site by clicking on the site name (Fig. 5).

Questionnaire: Step 1

Site Name:*

Installation ID:

Management Unit ID:*

* required fields

[Next](#)

Fig. 1

Job ID	Site Name	Location	Inverters	Panels
4	Sacramento	Sacramento 1	Fronius IG2000	Solar Power SP200
3	Berkeley	1115 University Ave, Berkeley, CA 94701		
2	Northern Italy - String Comparison			
1	Santa Cruz	E100 Soquel Ave, Santa Cruz, CA 95062		

Pending Sites

Job ID	Site Name	Actions
20157	East Warehouse	Configure Delete

Fig. 2

System: East Warehouse
Timezone: America/Los Angeles

Management Unit
Update management unit

Management Unit ID

Number of Gateways

Inverters
Enter Inverter information here

#	Type	Strings	Panels	Label	MPPTs	Max Power
1	Kaco2000	1	8	Kaco2000	1	3000

<< Back | Next >>

Copyright © 2007-2018 Tigo Energy, Inc. All rights reserved. 430 Shiloh Hill Road, Los Gatos, CA 95032 | P: +1 408 364 8100 | F: +1 408 364 8140

Fig. 3



Fig. 4



Fig. 5

The modules will be “gray” at this time until each Maximizer is connected to its corresponding PV module and the Management Unit establishes communication to:

- 1) the internet, and
- 2) the Maximizers via the Wireless Gateway (see Step 3.1).

1.2 SETTING UP THE “SYSTEM OWNER” PASSWORD AND PERMISSIONS

Log on to <https://datacenter.tigoenergy.com/main/installations.php>. Enter the installer’s login information and select the corresponding installation site name. Select the “Admin” tab from the MaxiManager feature menu. Select the “Users” tab on the lower menu bar.

Click the “Add New User” button on the bottom left of the window. A new pop-up screen will appear.

A screenshot of the 'Add New User' form. The form has a title bar 'Add New User' and several input fields: 'Login Name:', 'Password:', 'Retype Password:', 'First Name:', 'Last Name:', and 'Email:'. Below these is a 'User Type:' dropdown menu with 'System Owner' selected. At the bottom left, there is a link 'Show Advanced Options' and at the bottom right, a 'Submit' button.

In the space provided, enter the Login Name and Password (re-enter the password in the second box) which will be used as the system owner’s log in credentials. Record this information inside the front cover of the “System Owner’s Manual”. Enter the system owner’s first name, last name and e-mail address in the space provided.

Select the user profile (e.g. System Owner) from the “User Type:” drop down menu. This will configure the new user’s access rights to the default values as recommended by Tigo Energy. Default settings provide the system owner access to the screens that will be useful without overloading them with data. To modify these access rights (provide more or less feature access) click on the “Show Advanced Options” link. The radio buttons that appear in the lower half of the screen allow

the installer to select which screens and features will be available to the system owner. “Update” access provides full visibility with editing capabilities; “Browse” access provides read-only visibility; “None” removes the entire tab or feature from view when logging on as the system owner. Press the “submit” button to complete the addition, or close the screen without saving by clicking the “X” at the bottom right of the pop-up screen.



NOTE: only one account for a system owner may be created per license.

1.3 VERIFY SYSTEM INFORMATION



Once the configuration process is completed, enter the new site and select the ‘Admin’ tab to verify that all of the information is correct on the ‘Setting’ and ‘Site Details’ sub-tabs (Fig. 6).

Most of the information in these sections will have been auto-populated during the System Configuration process. Please verify that all of the information entered is correct, and fill in any missing fields if found.

1.4 ENTERING PHOTOS AND CHANGING THE APPEARANCE OF THE SUMMARY PAGE (OPTIONAL)

While still in the “Admin” tab of the MaxiManager application, select the “Appearance” tab.

Add pictures of the site by clicking the “Add New Picture” button. A pop-up screen will appear. Press “Choose File” to select a photo file from your computer directory. Press “Add a New Picture” button once the file has been selected to confirm the addition, or click the “X” in the lower right corner of the pop-up to exit without posting a photo. Repeat for additional photos. (Fig. 6)

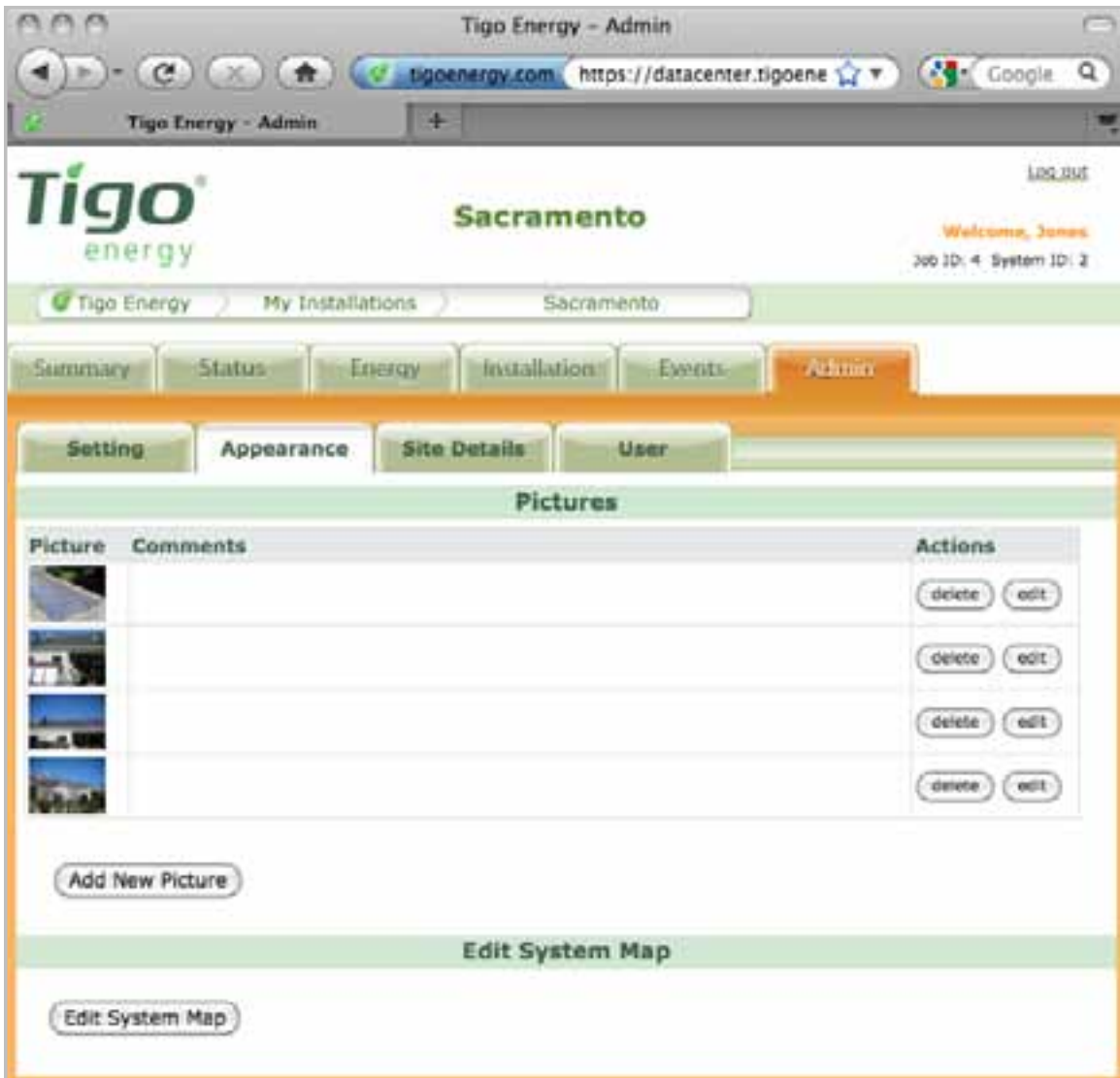

Fig. 6

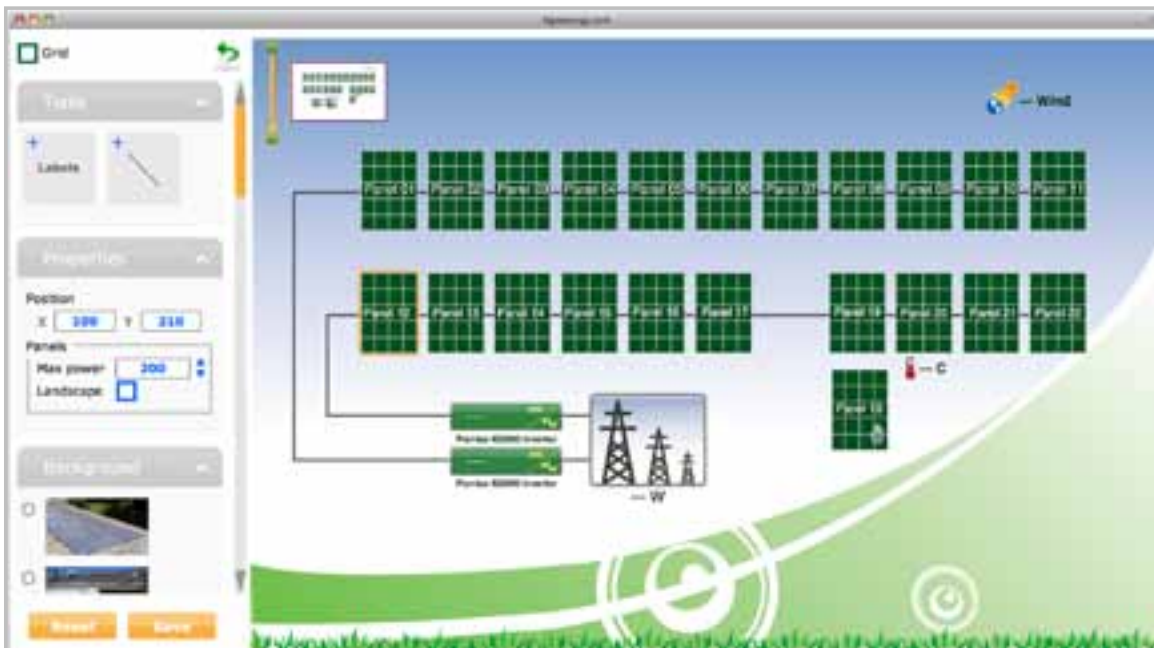

Fig. 7

To change the appearance of the “Summary” tab press the “Edit System Map” button. A pop-up screen will appear with the “Edit Tool,” which enables the installer to modify the appearance and placement of modules when they are on the “Summary Page” (Fig. 7). Modify the layout of the array by clicking and dragging modules with the cursor. To snap the modules to a grid, click the grid button in the upper left. Lines and labels can be added to the system map under the tools category. Clicking on anything in the picture will pull up the properties menu. In this menu modules can be moved and arranged in landscape orientation. A picture can be uploaded to the background of the site if the system owner chooses. This can be done under the background menu. Once all changes and additions have been made, click on the “Save” button to confirm. To view the changes that were made, select the “Summary” tab.

2

Install the Management Unit and Gateway

2.1 MANAGEMENT UNIT INSTALLATION

Ensure the AC and DC disconnect switches are in the OFF position for the inverter. Mount the Maximizer Management Unit (MMU) in a location that has access to an AC power source, a stable network connection, and proper cable connection to the Gateway.

The MMU should be mounted between 3 and 5 feet above the ground. Mounting tabs are provided for installing on unistrut or directly to a wall surface.

The power cord for the MMU is provided with the system kit and is connected to the terminal within the Maximizer Management Unit enclosure. For safety compliance, outdoor installations also require weatherproof housing be used to enclose the AC power adapter.



The Tigo Energy Maximizer Management Unit includes an external, weather-proof Ethernet port on the bottom surface. Connect an Ethernet cable (not provided) to a live port and then to the MMU. For outdoor installations, install a weatherproof cap (provided as an option) to the Ethernet port by threading the Ethernet cable through the cap, plugging in the Ethernet cable, screwing on the cap to the port, and hand tightening.



NOTE: If the array is going to be placed on a multi-roof surface, or contains more than 120 modules total, then this system requires more than one Gateway. Please contact your distributor for information on ordering additional Gateways.

The MMU is connected to the Gateway using an RS-485 cable. The cable should be a four-conductor, twisted pair, outdoor-rated wire of at least 18AWG. See Tigo Energy’s website for a list of tested cable options.

Access the MMU communications ports by pressing the latch at the bottom edge of the clear cover of the MMU and opening the enclosure. Remove the lower cover panel (which has the Tigo Energy logo) by unfastening the two screws in the bottom corners with a Phillips head screwdriver.

To install the RS-485 cable, completely remove the nut from the cable gland. Feed the cable through the nut, and the cable gland into the MMU housing. Attach the four wires to the cable connector terminal, which can be

removed from the circuit board for easier handling. Re-engage the connector into the RS-485 port on the right side. Take special care NOT to insert this in the Auxiliary RS-485 port. Note the wire colors used on the MMU connection so you can connect the other end of the wire to the Gateway with the same color configuration. Replace the nut on the cable gland and hand tighten. If four-conductor twisted pair cable is not available, then outdoor-rated Cat 5 Ethernet cable can be used instead. See Appendix B for instructions on installing Cat 5 cable.

Replace the lower cover panel, and securely fasten the two screws in the bottom corners with a Phillips head screwdriver. Close and latch the protective cover in the MMU.

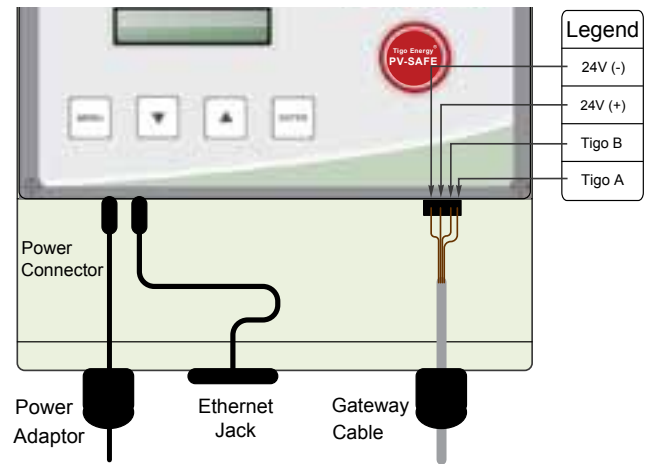

2.2 GATEWAY INSTALLATION

A Gateway is provided with the system kit to create the communications link to the Tigo Energy Module Maximizers. Install the Gateway onto the module frame in the top left corner by pushing the compression clips on the bracket onto the module metal frame and tightening the set-screw at a torque rating of 15-20 in lbs. to ensure bonding. The face of the Gateway (including the removable face and the label) should be facing out of the module frame. Confirm that the connectors are facing down. To connect the RS-485 cable to the Gateway, start by opening the cover of the Gateway. Keep the cover in a clean, safe place to prevent dirt from getting on the seal.

Insert the RS-485 cable through the left gland on the bottom of the Gateway. Tighten the cable wires into the bulkhead connector using a small screwdriver. Remove the connector from the circuit board for easier handling (Fig. 8).

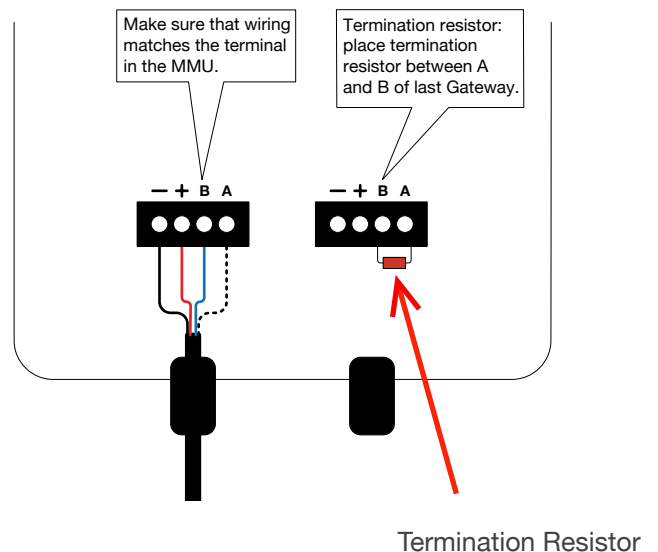

Fig. 8

Make sure that the wire connected to each terminal in the Gateway matches the connections in the Management Unit.

If the system has multiple gateways, use the second connection for the outbound cable to the second gateway. Remove the termination resistor (the small electrical component) from the right four-pin connector in order to wire the outbound RS-485 cable to the next Gateway. Only the final Gateway in the series connection should have a termination resistor.

When finished, replace the cover of the Gateway. Hand-tighten screws only.

2.2.1 GATEWAY LOCATION

The ideal location for the Gateway is underneath one of the central panels in the array so that the distance from any corner panel to the Gateway is the same. The Gateway comes pre-mounted on a bracket which can be attached to a module frame with the included clips. When attaching to a module place in the upper left hand corner with antenna pointing downward. Exact location can be optimized in Section 3.4.



NOTE: The Gateway should NOT be located where it may encounter direct exposure to sunlight or rain-fall, or be placed where the unit could be sitting in pooled water for long periods of time.

Position the Gateway at the center of the module cluster and attach to the upper left-hand corner of a PV module frame.



2.2.2 MULTIPLE GATEWAYS

In larger (those over 120 modules) or multi-surface PV projects, more than one Gateway will be required to support proper communications between the Maximizers and the MMU.

To plan the number of Gateways required for the design, partition the system into clustered blocks (up to 120 modules) or separate sub-arrays. The Module Maximizers in any block should not be more than 50 feet from the Gateway.

Place a Gateway in the physical center of each block or sub-array and connect the Gateways in series, using the second four-pin connector as the outbound cable from one Gateway to the next. Repeat this process until the final Gateway is installed.

Keep in mind that only the final Gateway in the series connection should have a termination resistor.

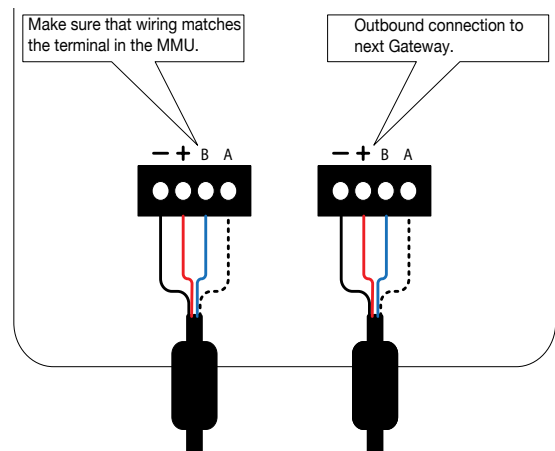

2.3 POWER ON THE MMU

IF A SENSOR BOX HAS BEEN ORDERED WITH THE SYSTEM DO NOT PROCEED BEFORE READING SECTION 2.4

Plug the MMU power cord into an AC outlet and ensure the MMU has access to the internet. Connect the MMU to the site's main AC power circuit (do not use a separate or dedicated power supply).

DO NOT INITIATE "DISCOVERY AND POWER ON" UNTIL ALL MAXIMIZERS HAVE BEEN INSTALLED.

Diagram A:
System layout showing Gateway mounted in center of arrays

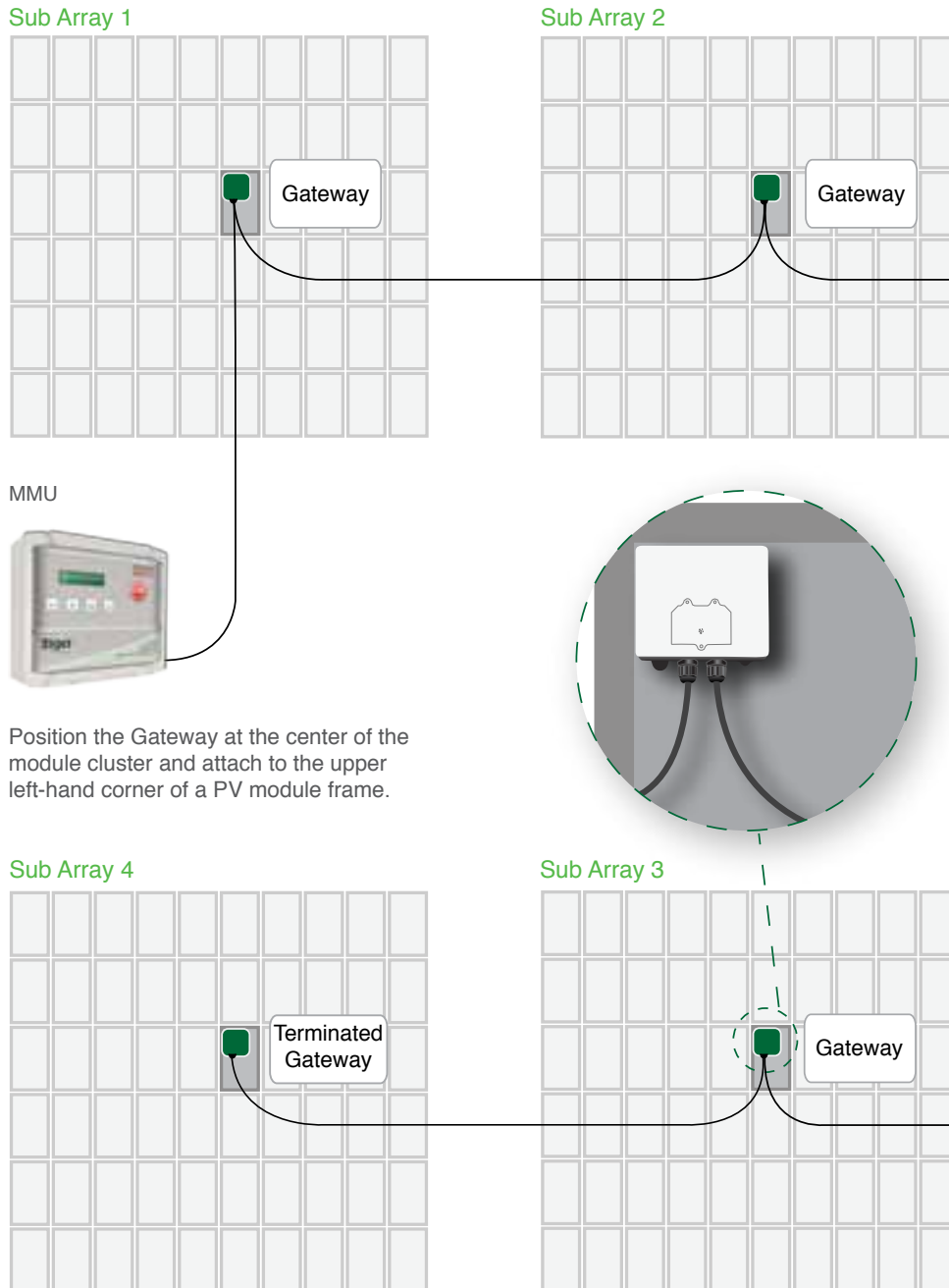

NOTE: To verify if a connection has been made to the network, the installer can perform a network test directly from the MMU (see networking troubleshooting in appendix C). If a laptop is available, select the 'Status' page to see when the MMU was last updated. If the 'Last Updated' section appears in red, then the MMU has NOT established connection to a viable network.

Once the MMU establishes connection to a network, the MMU will power up, perform configuration checks, download the latest system software if updates are available, and download the configuration data.

2.4 SENSOR INSTALLATION (OPTIONAL)



If additional sensors are required for the project for measuring light intensity, back-panel temperature, string current or voltage, these accessories may be ordered with the Tigo Energy® Maximizer™ System at the time of purchase.

The Tigo Energy sensor

accessories are powered RS-485 devices and are connected through the same RS-485 cable that connects the Gateway.

Install pyranometer, thermocouple(s) or current/voltage sensors within the array as desired. Place the Tigo Energy Sensor Box in close proximity to the sensor(s) within the array. The Sensor Box is provided with a module frame mounting bracket if frame mounting is desired and appropriate.

The sensor boxes are connected in series, identical to that of a multi-gateway system (see “Multi-Gateway Systems” for information on how to connect sensor boxes to the RS-485 chain). Be sure to install them before the final (terminated) Gateway in the circuit.

2.5 PLACEMENT OF THE CAUTION LABELS

Included with the system documentation are three labels which are essential to indicate that the PV system contains the Tigo Energy® Maximizer™ system with the PV-Safe™ feature and proper precautions are taken during the operation of the project.

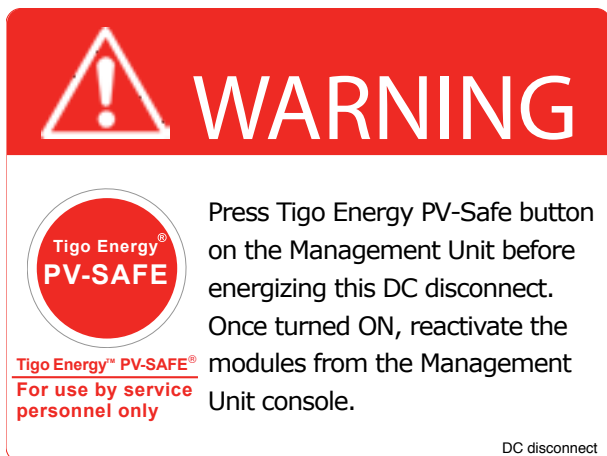

Figure 1

DC disconnect and fuse combiner box labels - contains the Tigo Energy PV-Safe logo and states (Figure 1) “⚠ WARNING Press Tigo Energy PV-Safe button on the Management Unit before energizing this DC disconnect. Once turned ON, reactivate the modules from the Management Unit console.”

Place these labels in a visible location on the front surface of the DC disconnect unit (typically found next to or integrated into the inverter) and on the front surface of the fuse combiner box (typically found adjacent to the array in multi-string projects).

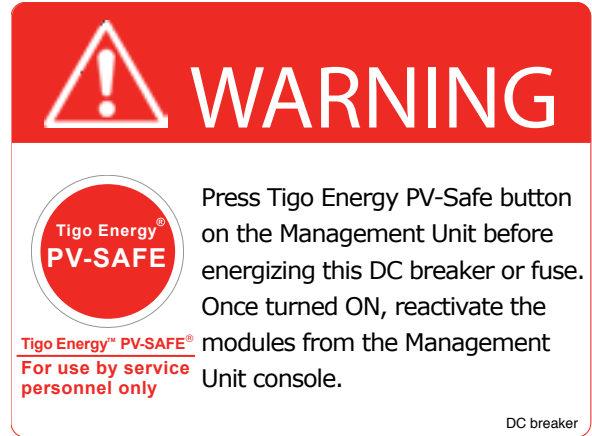

Figure 2

DC disconnect and fuse combiner box labels - contains the Tigo Energy PV-Safe logo and states (Figure 2) “⚠ WARNING Press Tigo Energy PV-Safe button on the Management Unit before energizing this DC breaker or fuse. Once turned ON, reactivate the modules from the Management Unit console.”

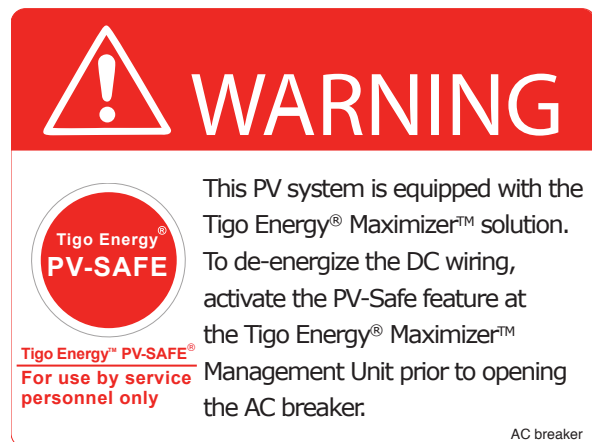



Figure 3

AC Disconnect Label-contains the Tigo Energy PV-Safe logo and states (Figure 3) “⚠ WARNING This PV system is equipped with the Tigo Energy® Maximizer™ solution. To de-energize the DC wiring, activate the PV-Safe feature at the MMU prior to opening the AC breaker.” Place this label in a visible location on the front surface of the AC Disconnect (typically found adjacent to the main circuit breaker panel).

3

Install the Maximizers and Verify System

 **NOTE:** The Tigo Energy Module Maximizers are factory configured in the “on” position and therefore may produce voltage as high as the PV module open circuit voltage (Voc). If there are two modules connected to a Maximizer MM-2ES, then the voltage can be as high as twice the module’s maximum power voltage. Please read “IMPORTANT SAFETY INSTRUCTIONS” at the beginning of this manual before starting installation.

Confirm that the PV module open circuit voltage (Voc) rating does not exceed the Tigo Energy Module Maximizer’s maximum input voltage specification. Also, confirm that the Vmp is within the range specified for the Module Maximizer. Confirm the PV module’s maximum short circuit current (isc) is within the rated current limit for the Module Maximizer (MM-ES and MM-2ES).

Note: During series connection of PV modules in reverse bias, the last Maximizer of the string may carry the highest absolute backfeed short circuit current.

Refer to the Tigo Energy module configuration tool at: www.tigoenergy.com/our_products for help.

Tigo Energy Module Maximizers are to be installed with the connectors facing downward and should be installed underneath the module, out of direct sunlight or rain. The Module Maximizers are to be mounted a minimum of three (3) feet above the ground. Failure to adhere to the installation instructions will result in voiding the warranty.

Install the Maximizer on the module frame in the top right corner by pushing the compression clips on the Maximizer bracket (included) onto the metal frame structure. The compression clips feature small barbs at the ends of the clips, which provide tension and bond the bracket to the module frame. When installing on a frame-less module or when the frame corner is inaccessible, mount the Module Maximizer directly to the rack structure. Holes are provided in the bracket to enable attachment to the mounting structure. Be sure to follow the guidelines in the previous paragraph.



Continue installing the Module Maximizers in sequential order (i.e. A1, A2, A3...etc) until the first string is complete. Repeat for additional strings (B1 ... Bn; C1 ... Cn; etc.) until PV array is complete. Note that when installing an MM-2ES, the numbers will sequence in increments of two (i.e. A1, A3, A5, etc.).



A Note on Grounding: The Tigo Energy Module Maximizer is enclosed in a polycarbonate (non-metallic) box that does not require additional grounding.

3.1 CONNECTING MAXIMIZERS TO MODULES

The installer should use the same caution when handling electrical cables from a PV module with or without the Tigo Energy Module Maximizer attached.

For each module connected to a Maximizer, plug the leads from the junction box into the input connectors (short wires) on the Maximizer.

If installing an MM-2ES, connect the second pair of short wires on the Maximizer. Note that the pairs are slightly different lengths to help avoid mis-wiring.

If there are an odd number of modules on the string, then an MM-2ES can be connected to just one PV module.



In that case, be sure to first short (connect together) the “Input B” pair of connectors, and then connect the single PV module to the “Input A” pair of connectors.

Always assume Maximizer is in on state, or may turn on when restarting.

You must complete this step before moving on.

3.2 WIRING TO ADJACENT MAXIMIZERS

Important: You must connect Maximizers to their PV modules before connecting Maximizers to each other in series. Failure to do this may damage the Maximizer.

On the first Module Maximizer of the first string, locate the positive lead (has a red sleeve next to the connector). Connect the red (+) output lead from the Module Maximizer to the extension cabling which connects to the string combiner or directly to the inverter.

FOR MM-ES: Locate the negative lead (has a blue sleeve). Connect the blue (-) output of the first Module Maximizer to the red (+) output wire of the second Module Maximizer. Connect the blue output of the second Module Maximizer to the red output lead of the third Module Maximizer.

FOR MM-2ES: Locate the negative lead (on the left most side of a properly installed Module Maximizer – has a blue sleeve). Connect the blue (-) output of the first Module Maximizer dual package to the red (+) output wire of the adjacent MM-2ES.

Connect the blue output of the second Module Maximizer to the red output lead of the third Module Maximizer. Continue these steps for all Module Maximizers. An extension cable (not included) may be necessary if two modules are not physically adjacent to one another. Connect the blue (-) output wire of the last Module Maximizer to the extension cabling which connects to the string combiner or directly to the inverter. (Fig. 9).

Mounting Configuration for MM-2ES Module Maximizer



Mounting Configuration for MM-ES Module Maximizer



Fig. 9

3.3 INITIATE DISCOVERY AND POWER ON

Once all of the Maximizers have been connected to their modules, return to the Management Unit and initiate the “Discovery and Power On” command, which will also power on the Maximizers (if they not powered on already). Access this from the MMU display by selecting “2 Control”, then “2.1 Discover/Pwr”.

The discovery process will initiate communication between the MMU and Maximizers, and verify the Maximizer IDs against the list of Maximizer IDs in the configuration file for the system. Once the discovery process has been run, the Maximizers will power on. At this point, the system can produce power, and the voltage from each Maximizer can be as high as the maximum power voltage of its PV module. The discovery process will take approximately 15 minutes for each Gateway.

The MMU screen will display the status of the system during discovery:

Message	Description
“Find Gateways...”	Searching for Gateways
“Found: X/Y”	Found X Gateways out of Y total Gateways
“Gateways: OK”	Correct number of Gateways found, and all Gateways are functional
“Channel Check...”	Verifying radio channel for Gateways
“Assign X/Y”	Assigning Maximizer X out of Y total Maximizers
“Step[X/Y]: P%”	Each step corresponds to the discovery process of a Gateway (Y total Gateways), with the percent complete indicated of each step. The percent completed will reset each time a new Maximizer is discovered
“Found X/Y”	Found X Maximizers out of Y total; still processing
“Done X/Y”	Discovery process is finished. X Maximizers were found and assigned out of Y Maximizer in configuration

If any error codes come up during the discovery process, see the list of discovery error codes in Appendix C. When finished, the MMU screen will indicate that all Maximizers have been successfully discovered and assigned (e.g.: “Done: 36/36”).



If an internet connection is available on-site, go to the Status Page once all Maximizers are connected to the panels to ensure they are all connected properly, registering voltage, and receiving a sufficient RSSI.

If installing a multi-string system, you must initiate Discovery and Power On before connecting strings in parallel.

3.4 VERIFY GATEWAY SIGNAL

Locate the MMU display to aid in placement of the Gateway. If the Gateway is placed in a location that is not ideal for stable communication with the Tigo Energy Maximizers, two messages will appear on the MMU display.



NOTE: For troubleshooting purposes, the weakest panels are sorted to appear first in the list.

You must successfully complete this step before moving on to the rest of the installation process.

The first will say “Panel Not Comm.” and will provide a count of how many Maximizers out of the total in the array are not communicating with the Gateway (e.g. Panel Not Comm. 3/14). The second will say “Panel Signal Low” and will provide a count of how many Maximizers out of the total that are already communicating with the Gateway that have weak signal strength, and thus are unable to communicate effectively with the Gateway. By paying close attention to these warning messages, the installer can locate the most ideal place for the Gateway to be able to communicate effectively with all of the Maximizers in the array.

Proactively validate the signal strength by lifting the protective cover on the MMU and selecting the “MENU” button. Select “1. STATUS”, and then “1.1. PANELS”. Finally, select “1.1.1. SIGNAL”. This part of the MMU menu will display all of the configured panels in a list with signal strength marked next to each panel. Use the up and down arrows to scroll through the list. Pressing “ENTER” will allow you to take a new reading of the PV array’s signal strength.

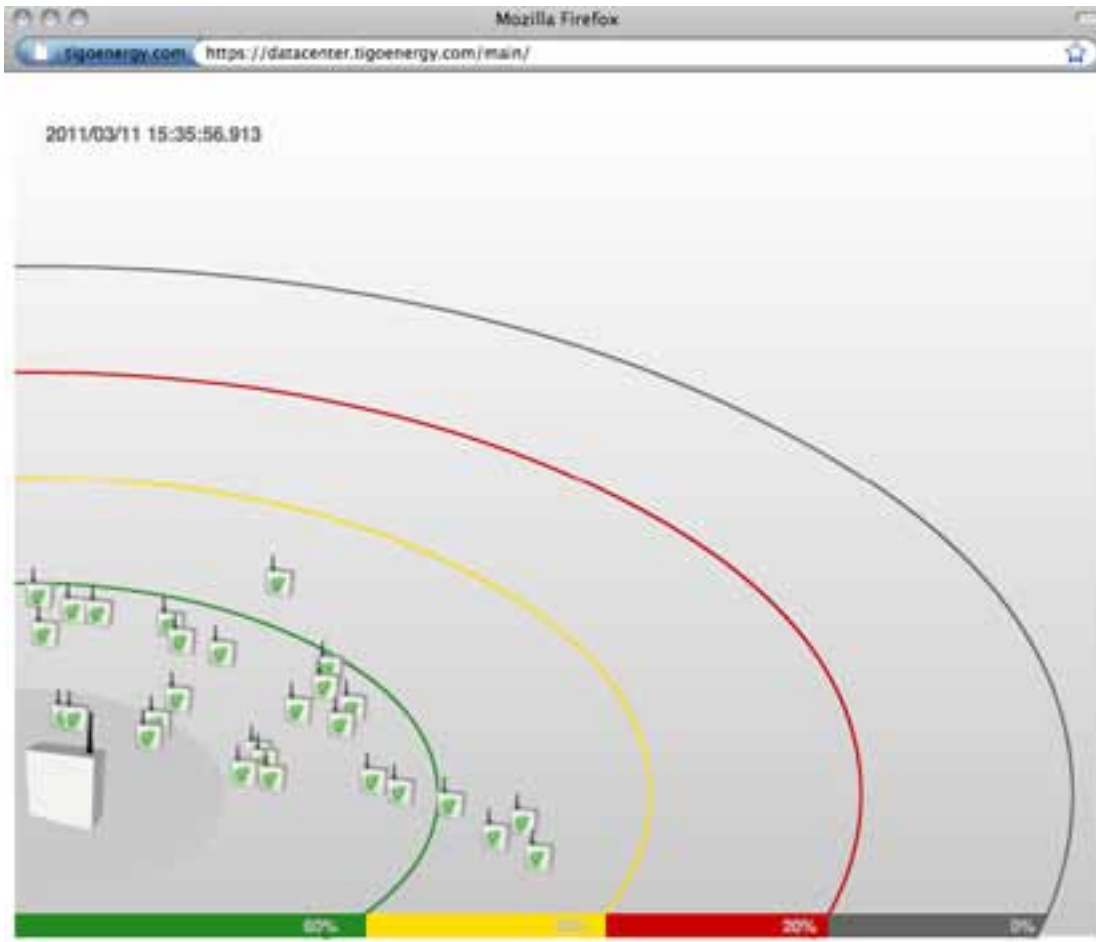

CONNECTOR LAYOUT - MM-ES

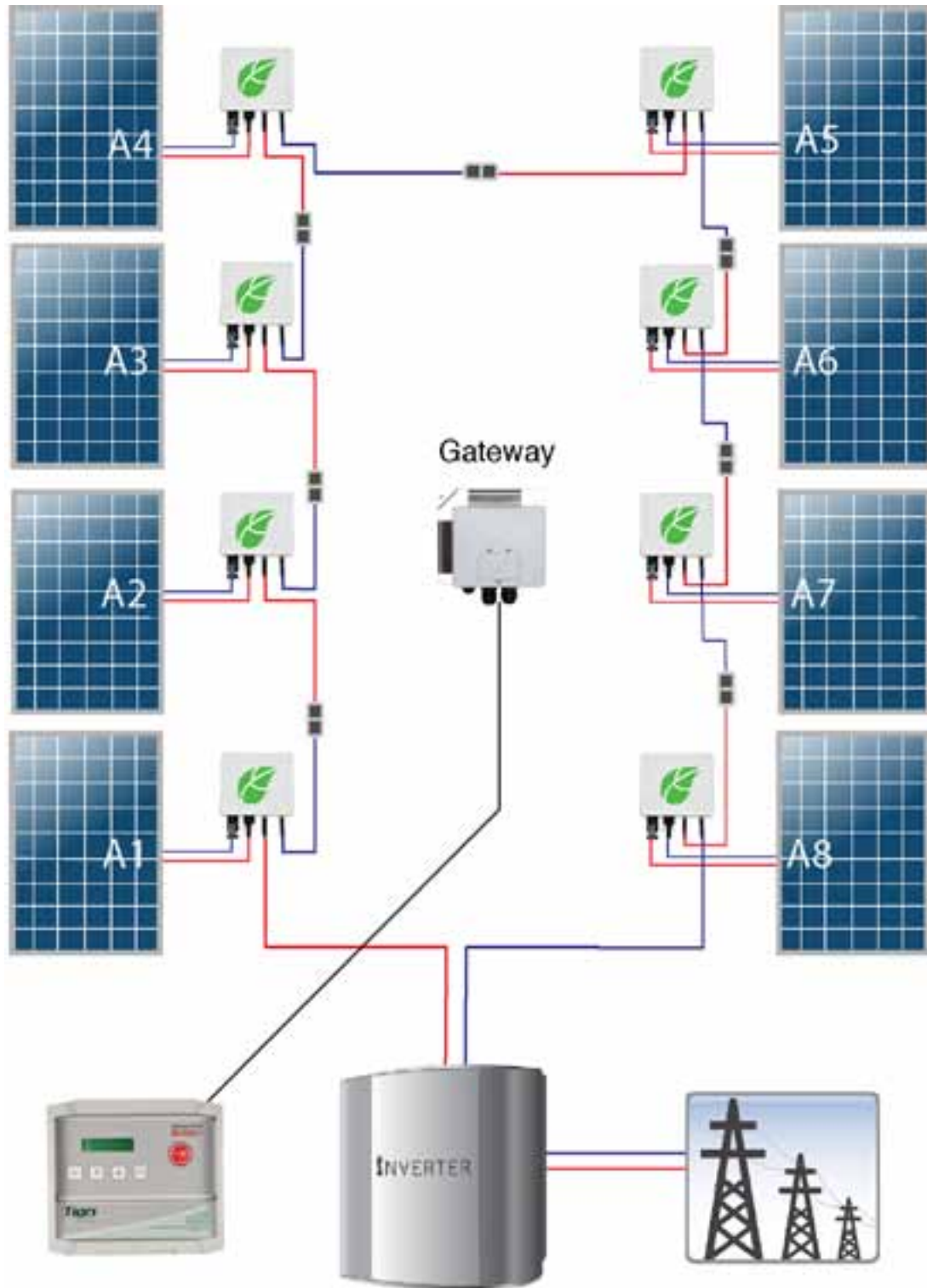

CONNECTOR LAYOUT - MM-2ES

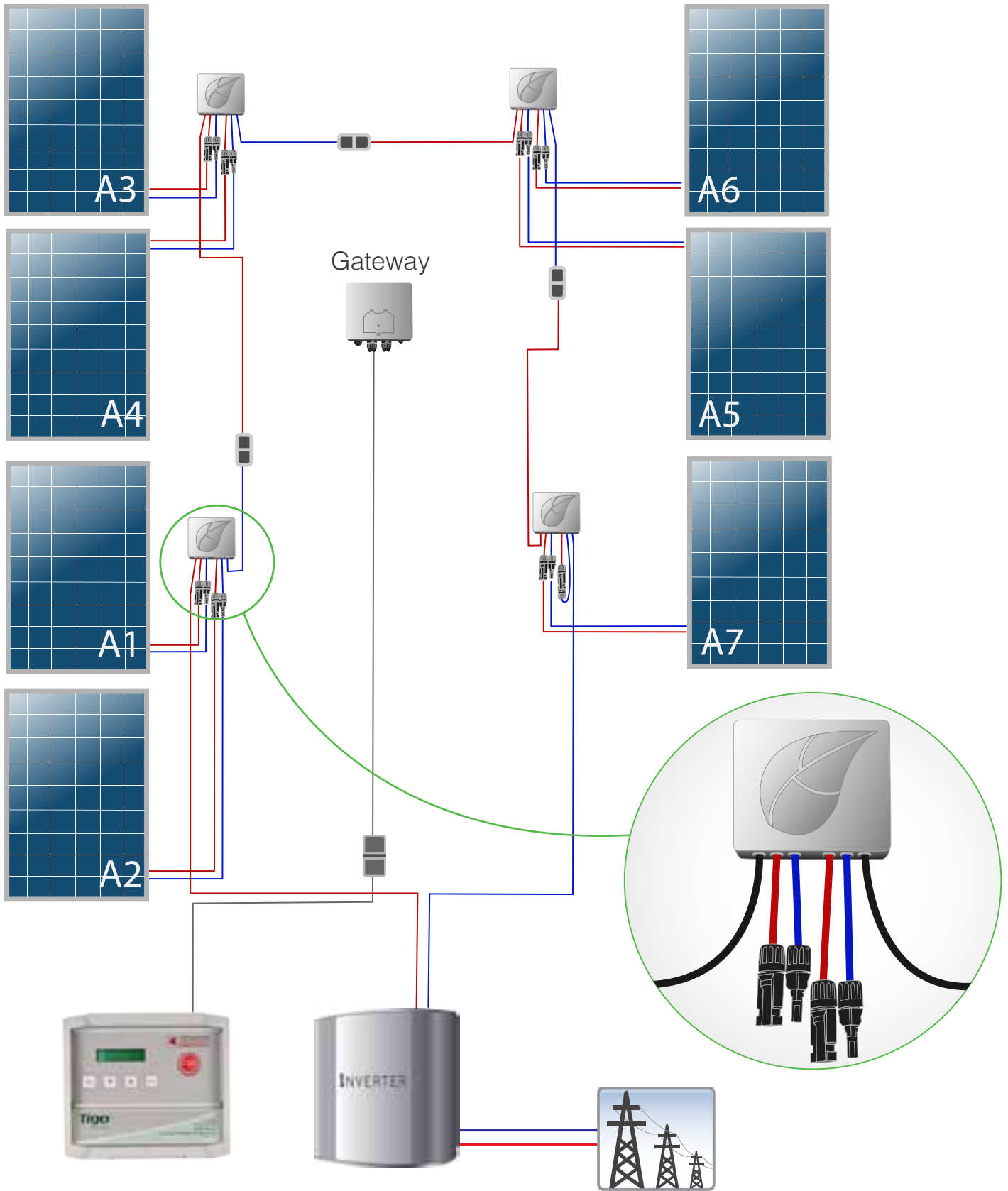

3.5 Test String Polarity, Tigo Energy® PVSafe™ Function and Power



3.5.1 STRING VOLTAGE POLARITY CHECK

As with any installation of a PV system, the installer needs to verify polarity and voltage of each string before connecting them in parallel with one another. This is still the case with a Tigo Energy system.

The MMU display can help confirm voltage readings for each of the panels in each string. Lift protective cover on the MMU and select “MENU”. Select “1. STATUS”, then select “1.1. PANELS”. Scroll down and select “1.1.2. VOLTAGE”. The display will show a list of all the configured panels in the PV array with voltages marked next to each panel. Pressing “ENTER” will refresh the screen and provide the most current voltage readings for all of the panels. Make a note of any string that has reverse polarity and/or any string that may not have full Voc voltage at this time to address after the testing the PV-Safe function next.



3.5.2 TEST PV-SAFE FUNCTION



Depress the latch to open the clear protective cover on the MMU and press the button labeled “Tigo Energy PV-Safe” on the Tigo Energy Maximizer Management Unit.

When the PV-Safe button is activated, the MMU will display “PV-SAFE PRESSED” and “Requesting ...” to indicate the command has been sent to the Maximizers. As the Maximizers are responding, the MMU display will indicate how many have successfully disconnected (e.g. “Resp: 15/48”).

Once the system successfully receives acknowledgement from all of the Module Maximizers in the array, the MMU will display “RESPONDING”.

Should the MMU not receive proper response from one or more of the Module Maximizers or communication has been lost, the display will read “NOT RESPONDING”. If this message is present, the owner or installer must assume that the system is still active and voltage is present as in a standard PV array. Refer to the Troubleshooting section for instructions on verifying the system communication is operating properly.

Please ensure safety precautions are always observed to avoid contact with solar wiring regardless of the state of PV-Safe. Tigo Energy cannot guarantee that modules are fully deactivated. The Maximizers may still be energized. The Tigo Energy PV-Safe feature is not a mechanical disconnect.

Please note that in the case that the PV-Safe feature is triggered automatically (by disconnecting the AC breaker or from a prolonged grid outage), the Maximizers will immediately shut off for safety. However, the following morning (after the Maximizers reset), they will power on and there will be voltage present on the lines, even if the inverter and MMU are inactive.



NOTE: This step should be performed at the installation and annually thereafter to ensure that the PV-Safe function is in good working order. These same steps can be used when activating the feature for system maintenance or emergency services.



3.5.3 CORRECT ANY IDENTIFIED ISSUE

At this time, if any strings have reverse polarity proceed with corrective rewiring of the strings and go back and redo this step to verify that the issue has been corrected. If the voltage is not as high as expected, this may be an indication that one or more of the Maximizers in the string is not working properly.

This can also be verified from the Summary tab on the MaxiManager web-interface. Grey panels indicate no communication. If this is the case go back to Step 3.4.1 to relocate the Gateway for better communication with all Maximizers in the array. Proceed to the next step when all Maximizers are communicating with the MMU.



3.5.4 POWER PRODUCTION CHECK

The MMU display can be used to verify power production for each panel in the PV array. Lift protective cover on the MMU and select “MENU”. Select “1. STATUS”, and then “1.1. PANELS”. Scroll down to select “1.1.3. POWER”. The display will show a list of all the configured panels in the PV array with wattage values marked next to each panel. Pressing “ENTER” will refresh the screen and display the most current power output readings for all of the panels in the array.

Since PV-Safe has been activated, you must now activate the panels: First Lift the protective cover on the MMU and select the “MENU”. Scroll down to select “2. CONTROL”. Scroll down to select “2.1. PANELS ON”. Press “ENTER” again to confirm.



APPENDIX

TIGO ENERGY® MAXIMIZER™ MANAGEMENT UNIT MENU

	COMMAND	DESCRIPTION
1. Status		
	1. Panels	Real-time status of each of the connected panels in the system.
	1. Signal	All configured solar panels are shown in a list, with signal strength displayed for each. User can press Up/Down arrows to scroll through the list; and Enter to take a new reading of signal strength. For quick identification during troubleshooting, the weakest panels are sorted to appear first in the list.
	2. Voltage	Same as Signal, but displays DC voltage of each panel.
	3. Power	Same as Signal, but displays how many watts of power each panel is producing.
	2. Date/Time	Clock read-out. Time is automatically set from the Internet connection, each time the MMU is rebooted. If the Internet connection has yet to be established, time display will likely be inaccurate.
	3. Unit ID	Shows the ID of each management unit, a 12-letter code. This will also be the MAC address of the Ethernet port (useful for network troubleshooting).
2. Control		
	1. Discovery	Initiates communication with all Maximizers, and powers them on.
	2. Panels ON	Connects power to all solar panels. Use this to turn the system back on, after having earlier hit the "PV-Safe" button to turn the system off.
	3. Push Data	Immediately attempts to make another communication to transfer data to the Tigo Energy data center, without having to wait the usual 10 minute period between communications. Useful for real-time debugging.
	4. Restart	Reboots the Maximizer Management Unit.

	COMMAND	DESCRIPTION
3. Network		
	1. Display IP	Shows the IP address of the Maximizer Management Unit, on the premise network. Very useful to determine connectivity.
	2. Test	Validates the connection to the Tigo Energy data center, without transferring data. Displays "Success" if the Internet connection is functional.
	3. Configure	Configures the MMU's wired Internet connection. This is a sequence of steps, where the operator will be asked a series of yes/no questions, and also asked to enter data if necessary. Indicating "Yes", when asked "Automatic IP?", will use DHCP - the easiest and best configuration for most connections.
	4. Set Proxy	Configures the use of a proxy server for HTTP requests when transferring data to the Tigo Energy data center. Not recommended, unless necessary to get through a corporate firewall.
	5. Set Default	Sets the management unit to a temporary static IP address of 192.168.0.15. Rarely useful, except for testing during network troubleshooting.
	6. Renew	Resets the IP address of the MMU. If "Automatic IP" is chosen, uses DHCP to request another IP address. This should be done after making any changes to the premise router configuration, or any changes to the Ethernet connection.

B

INSTALLING CAT 5 CABLE BETWEEN THE MMU AND GATEWAY

If four-conductor twisted-pair cable is not available, then the MMU-Gateway connection can be wired with Cat 5 Ethernet wire. The data feed (leads A and B on the MMU and Gateway terminal blocks) must be connected to the same twisted pair. See the table for instructions on connecting the cable:

Gateway/MMU Terminal Label	Signal	Cat 5 Cable Color(s)
A	RS485 (+)	Blue/White Stripes
B	RS485 (-)	Blue
+	+24v	Orange Green Brown
-	GND	Orange/White Stripes Green/White Stripes Brown/White Stripes

C

TROUBLESHOOTING

**WARNING:**

Servicing Instructions: “Warning - These servicing instructions are for use by qualified personnel only. To reduce the risk of electric shock, do not perform any servicing other than that specified in the operating instructions.”

**WARNING:**

The Module Maximizers contain no user-serviceable parts. Do not attempt to open the enclosure. Tampering with or opening the Module Maximizer will void the factory warranty. See warranty for instructions on obtaining service.

**WARNING:**

Troubleshooting the PV array or the Tigo Energy Module Maximizers should be completed only by qualified personnel. Disconnect maximizer from all solar panel connectors before servicing. Do not disconnect PV connectors under load.

Download the most recent version of this Installation Manual from:

<https://datacenter.tigoenergy.com/main/installations.php>

Troubleshooting the Gateway connection

The Tigo Energy Gateway has an LED light at the bottom of the unit, which shows the status of the Gateway. This is useful for troubleshooting problems with the system communications. See the table below for the meaning of each light pattern:

Color pattern	Gateway Status
No color	Not powered from MMU
Solid blue	Powered, but not communicating
Blue and yellow (blinking)	Powered and communicating with Maximizers

DISCOVERY PROCESS ERROR MESSAGES

If error messages are displayed during the discovery process, see the table below for descriptions of the problem.

Error message	Description	Corrective action
“Err#1: X/Y”	MMU has only found X Gateways (was expecting to find Y)	Check Gateway cable connections, call Tigo Energy Support if problems persist
“Err#3: XXXX” “Err#4: XXXX” “Err#6: GW_XXXX err” “Err#7: GW_XXXX err” “Err#6: GW_XXXX err” “Err#10: GW_XXXX err” “Err#11: MM pos” “Err#12: GW_XXXX err” “Err#13: GW_XXXX err”	Failed Gateway communication during discovery, cannot find Gateway XXXX	Check Gateway cable connections, call Tigo Energy Support if problems persist
“Err#5: Chnl err”	Could not find free channel for Gateway	Contact Tigo Energy Support

TROUBLESHOOTING THE NETWORK CONNECTION TO THE TIGO ENERGY® MAXIMIZER™ MANAGEMENT UNIT

To verify the integrity of the MMU network connection, start by lifting the protective cover on the MMU and press the “MENU” button – then press “ENTER”. Use the down arrow to select “3. Network”– then press “ENTER”. Scroll to “3.2. Test” – then press “ENTER”.

While the test is running, the screen will display a variety of messages to indicate the status of the network test:

Message	Description	Corrective Action
“Connecting...”	Trying to access Tigo Energy’s server	N/A
“Success.”	MMU has successfully accessed the server	N/A
“Error: checking”	MMU could not connect to the Tigo Energy server, and is diagnosing cause of problem	N/A
“Cable unplugged”	No physical cable detected	Check cable connection and re-initiate network test
“Check proxy svr”	MMU is configured to access the web via HTTPS proxy, and server is not cooperating	Verify proxy settings on MMU. Verify proxy server allows access to https://datacenter.tigoenergy.com . Re-initiate network test
“No default GW”	Missing default gateway. Either DHCP server is not replying, or static configuration entry is not present	Verify physical connection at router. Verify configuration of router allows MMU to access network. Re-initiate network test

Message	Description	Corrective Action
"Cannot ping GW"	Default gateway did not respond to ping. May not be a problem, depending on router configuration	Verify physical connection of cabling at router and re-initiate network test
"Cannot ping DNS"	Global public DNS server (8.8.8.8) is not responding. Indicates possible inability to connect to internet. May not be a problem, depending on router configuration	Check internet connection and re-initiate network test
"Cannot ping Tigo"	Cannot exchange ICMP packets with Tigo Data Center. May not be a problem, depending on router configuration	Contact Tigo Energy's Customer Support team at +1.888.609.8446 or support@tigoenergy.com

TO CHECK THE LOCAL NETWORK FOR ISSUES:

1. Check with the network administrator to make sure the network provides the IP address automatically to computers that connect to it. The MMU is configured to obtain an IP address from the network automatically through a DHCP server. If the network requires a static IP address see section below.
2. Check if the network cable is functional. If the cable is working and the MMU is connected to an active network switch through the cable, the LED should blink at the switch port connection.
3. Check the network connection with a laptop computer. Verify the network connection to the MMU by disconnecting the network cable from the MMU and connecting it to a laptop. If the laptop can access the web but the MMU cannot, contact the Tigo Energy support hotline.
2. Bring this information and locate the Tigo Energy Maximizer Management Unit. Depress the latch to open the clear protective cover on the MMU and press the "MENU" button – then press "ENTER". Scroll to "3. Network" – then press "ENTER". Scroll to "3.3. CONFIGURE"- then press "ENTER".
3. The display will read "ARE YOU SURE?" AND "Y=ENTER, N=MENU". To proceed press "ENTER". The display will read "AUTOMATIC IP?" AND "Y=ENTER, N=MENU". To proceed press "MENU". Then the display will read "IP ADDRESS:" AND "000.000.000.000". Notice the cursor is under the left most zero. Use the scroll up and down keys to change the value of the number. Use the "ENTER" key to move right and the "MENU" key to move left. When the cursor is on the right most digit, you can move to the next input screen by pressing "ENTER".

SETTING UP A STATIC IP ADDRESS

1. Contact the network administrator and obtain the following information:

Static IP address assigned to the MMU:	
Subnet Mask:	
Default gateway:	
Preferred DNS server:	
Alternate DNS server:	

4. The next entry field will read "SUBNET MASK" AND AGAIN "000.000.000.000". Use the four keys as before to move and change the number values.
5. The next entry field will read "DEFAULT GATEWAY" AND AGAIN "000.000.000.000". Use the four keys as before to move and change the number values.
6. The next entry field will read "PREFERRED DNS SERVER" AND AGAIN "000.000.000.000". Use the four keys as before to move and change the number values.
7. The next entry field will read "ALTERNATE DNS SERVER" AND AGAIN "000.000.000.000". Use the four keys as before to move and change the number values.
8. The final field will read "SAVE SETTING?" and "Y=ENTER, N=MENU". Press "ENTER" to complete the entry of a new static IP address for the MMU.

TROUBLESHOOTING – MAXIMIZER ID

If there is an error with the Maximizer IDs, these can be edited directly through the software interface. From “My Installations”, click on the project you would like to edit. Then select the “Admin” tab, and the “Site Details” sub-tab. Scroll to the bottom of this page to find a button labeled “Edit Configuration.” From the edit section, hit “Next” twice.

You will now find yourself on the Maximizer ID page, where you can edit the incorrect IDs. When you are done, click “Save” to save your changes.

TROUBLESHOOTING MODULES WHICH ARE NOT SEEN BY THE TIGO ENERGY® MAXIMIZER™ MANAGEMENT UNIT.

If the Tigo Energy® Maximanager™ Software in the “Summary” view shows the module as powered off, when it is expected to be active:

1. Check that the physical connections between the PV module and the Module Maximizer are complete and secure.
2. Refresh the web browser configuration and check to see if the panel has refreshed.
3. If the problem persists, determine if the Module Maximizer is out of communication range of the MMU. This can be determined by the performance of other Module Maximizers in close proximity.
4. If the signal strength is too low, install or reposition the Gateway.
5. Once complete, refresh the browser to check if the module is now visible and active.

Call the Tigo Energy installation support line if problems persist:

(USA) +1.888.609.TIGO (8446);
(Europe) +800-CALL-TIGO (2255-8446)

CONFORMANCE CERTIFICATION – SAFETY

The Tigo Energy Module Maximizer and Maximizer Management Unit comply with the appropriate sections of the following International Standards to maintain the CE conformity mark:

- EN60950-1:2006 Information Technology Equipment - Safety - Part1: General Requirements
- EN60529 Degrees of Protection Provided by the Enclosure (IP65)

Compliance Statement

This equipment generates, uses and can radiate radio frequency energy and, if not installed and used in accordance with the instructions, may cause harmful interference to radio communications. However, there is no guarantee that interference will not occur in a particular installation. If this equipment does cause harmful interference to radio or television reception, which can be determined by turning the equipment off and on, the user is encouraged to try to correct the interference by one or more of the following measures:

- Reorient or relocate the receiving antenna.
- Increase the separation between the equipment and the receiver.
- Connect the equipment into an outlet on a circuit different from that to which the receiver is connected.
- Consult the dealer or an experienced radio/TV technician for help.

This device complies with Part 15 of the FCC Rules. Operation is subject to the following two conditions: (1) this device may not cause harmful interference, and (2) this device must accept any interference received, including interference that may cause undesired operation.

Changes or modifications not expressly approved by the party responsible for compliance may void the user's authority to operate the equipment.

LIMITED WARRANTY

WORKMANSHIP AND MATERIALS

Tigo Energy® warrants all Equipment to be free from defects in material or workmanship under normal use and service for a period of ten (10) years from the date of installation at customer site. Furthermore, if within twenty (20) years from date of delivery to the Customer, any Tigo Energy® Module Maximizer™ exhibits a power output less than 80% of the Minimum Peak Power as specified at the date of delivery by the module vendor's data sheet, provided that such loss in power is determined by Tigo Energy (at its sole and absolute discretion) to be due to defects in material or workmanship, Tigo Energy will repair or replace the defective Tigo Energy Module Maximizer(s). During the Warranty Period, Tigo Energy will, at its option, repair or replace the defective product free of charge, provided that Tigo Energy through inspection establishes the existence of a defect that is covered by the Limited Warranty. Tigo Energy will, at its option, use new and/or reconditioned parts in repairing or replacing the Defective Product. Tigo Energy reserves the right to use parts or products of original or improved design in the repair or replacement of Defective Product. If Tigo Energy repairs or replaces a Defective Product, the Limited Warranty continues on the repaired or replacement product for the remainder of the original Warranty Period or ninety (90) days from the date of Tigo Energy's return shipment of the repaired or replacement product, whichever is later. The Limited Warranty covers both parts and labor necessary to repair the Defective Product, but does not include labor costs related to uninstalling the Defective Product or re-installing the repaired or replacement product. The Limited Warranty also covers the costs of shipping repaired or replacement product from Tigo Energy, via a non-expedited freight carrier selected by Tigo Energy. The Limited Warranty does not cover, and Tigo Energy will not be responsible for, shipping damage or damage caused by mishandling by the freight carrier and any such damage is the responsibility of the freight carrier.

LIMITATIONS AND CONDITIONS

Tigo Energy Module Maximizers are designed to withstand normal operating conditions and typical wear and tear when used for their original intent and in compliance with the installation and operating instructions supplied with the original equipment.

The Limited Warranty does not apply to, and Tigo Energy will not be responsible for, any defect in or damage to any Tigo Energy Module Maximizer: (1) that has been misused, neglected, tampered with, altered, or otherwise damaged, either internally or externally; (2) that has been improperly installed, operated, handled or used, including use under conditions for which the product was not designed, use in an unsuitable environment, or use in a manner contrary to the Tigo Energy User Manual or applicable laws or regulations; (3) that has been subjected to fire, water, generalized corrosion, biological infestations, acts of God, or input voltage that creates operating conditions beyond the maximum or minimum limits listed in the Module Maximizer specifications, including high input voltage from generators or lightning strikes; (4) that has been subjected to incidental or consequential damage caused by defects of other components of the PV system; or (5) if the original identification markings (including trademark or serial number) of such Module Maximizer have been defaced, altered, or removed. The Limited Warranty does not cover costs related to the removal, installation or troubleshooting of the customer's electrical systems. The Limited Warranty does not extend beyond the original cost of the Maximizer. In order for the warranty to be valid and prompt service obtained, customers must have Tigo Energy monitoring enabled and paid for through the time of the service request. See RMA process for easy return policies, next page.

LIMITED WARRANTY CLAIMS

To obtain repair or replacement service under this Limited Warranty, the customer must comply with the following policies and procedures:

- Customers must have Tigo Energy monitoring enabled so that Tigo Energy Authorized Representatives can view the Module Maximizers on the array over the Internet. If the product is deemed to be defective by the Tigo Energy representative, a replacement Module Maximizer will be shipped to the customer site with an RMA number and appropriate box for the customer to return the defective Module Maximizer. Customer must provide correct shipping address.
- All Defective Product must be returned with a Return Merchandise Authorization Number (RMA) provided by Tigo Energy.
- In order to complete the RMA process, customer must provide the following information:
 1. Proof-of-purchase of the Defective Product in the form of the dated purchase receipt from the original purchase of the product at point of sale to the end user, or (2) the dated dealer invoice or purchase receipt showing original equipment manufacturer (OEM) status.
 2. Model number of the Defective Product.
 3. Serial number of the Defective Product.
 4. Detailed description of the defect.
 5. The returned Defective Product must not have been disassembled or modified without the prior written authorization of Tigo Energy.



Declaration of Conformity

Tigo Energy, Inc.
420 Blossom Hill Road
Los Gatos, CA 95032

Declares that under our sole responsibility the product:

Product: Solar Module Maximizer
Product Model Type: MM-ES50 and MM2-ES

Conforms to the following Product Specifications:

EMC: EN55022, EN61000-6-2 and EN61000-6-4

The product herewith complies with the requirements of
the EMC Directive 2004/108/EC

Date and Place of issue: October 2010, Los Gatos, CA USA

Ron Hadar
President
Los Gatos, California

Danny Eizips
Director of Engineering
Los Gatos, California

TECHNICAL SPECIFICATIONS

Tigo Energy® Module Maximizer™ MM-ES50, MM-ES75, MM-ES 110, MM-ES170, MM-2ES

Electrical Specifications					
For electrical specifications refer directly to label found on the Tigo Energy Module Maximizer.					
Input Data	MM-ES50	MM-ES75	MM-ES110	MM-ES170	MM-2ES (per input)
Maximum power	300W	350W	300W	300W	300W
Maximum input DC voltage (Voc)	52V	75V	110V	170V	52V
Vmp range	16-48V	30-65V	30-89V	30-140V	16-48V
Output voltage range	0-Vmp	0-Vmp	0-Vmp	0-Vmp	0-Vmp
Maximum continuous current (Imp)	9.5A	6.5A	4.7A	2.6A	9.5A
Maximum input current (Isc)	10A	7.5A	5A	3A	10A
Reverse current mode	15A	15A	15A	15A	15A

Mechanical Specifications	
Dimensions (LxWxH)	120x104x25 mm
Weight	MM-ES - 680 g MM-2ES - 800 g
Connector	MC4 Tyco (Note when using Tyco connectors: positive lead mates with male connector keyed positive or neutral. Negative lead mates with female connector keyed positive or negative.)
Cable	PV Wire type 12 AWG, 4mm ²
Environmental Specifications	
Operating temperature range	-30° C to +70° C
Cooling	Natural Convection
Environmental rating, Protection Degree	NEMA 3R, IP65
Overvoltage Category	OVP III
UV/Anti-flammability rating	UV-F1 / UL 94-5VA

Regulatory Compliance	
North America	FCC part 15
European Union	EN 61000s UL 1741

Tigo Energy® Maximizer™ Management Unit

Electrical Specifications	
Single MMU controls up to 360 modules Single MMU connects with up to 7 Gateways Single Gateway communicates with up to 120 modules	
Communication (MMU to Data Center)	
Ethernet	802.11b/a/g;
WiFi or Cellular modem (optional accessories)	WEP and WPA security

Mechanical Specifications	
Dimensions (LxWxH)	245 x 150 x 80 mm
Weight	1177 gm
Environmental Specifications	
Operating Temperature Range	0° to +70° C
Storage Temperature Range	-40° to +70° C
Pollution Degree	Min PD3
Wet Location	No
Relative Humidity Range	5% to 95% (Noncondensing)
Climatic Conditions	Class 4K4H (per EN 50187)

Regulatory Compliance	
North America	EN 60950
Canada	ICES-003 CLASS B
European Union	Class B EN 61000

CERTIFICATE

of Conformity

EC Council Directive 2004/108/EC

Electromagnetic Compatibility



Registration No.: AE 72112663 0001

Report No.: 31160046 001

Holder: Tigo Energy
420 Blossom Hill Rd
Los Gatos CA 95032
USA

Product: Processing Machine
Maximizer

Identification: Model Designation: ES50
Serial Number: 04C05B1000004A1A

Tested acc. to: EN 55011:2007+A2
EN 61000-4-2:1995+A1+A2
EN 61000-4-3:2006+A1
EN 61000-6-1:2007
EN 61000-6-2:2005
EN 61000-6-3:2007
EN 61000-6-4:2007
FCC Part 15 Subpart B:2010



This certificate of conformity is based on an evaluation of a sample of the above mentioned product. Technical Report and documentation are at the Licence Holder's disposal. This is to certify that the tested sample is in conformity with all provisions of Annex I of Council Directive 2004/108/EC. This certificate does not imply assessment of the production of the product and does not permit the use of a TÜV Rheinland mark of conformity. The holder of the certificate is authorized to use this certificate in connection with the EC declaration of conformity according to the a.m. Directive.

Certification Body

Date 25.10.2011

Bruce Fagley

TÜV Rheinland LGA Products GmbH - Tillystraße 2 - 90431 Nürnberg

CE The CE marking may only be used if all relevant and effective EC Directives are complied with. CE





Contact Us:

+1.888.609 TIGO (8446)
customer support line (toll-free in US)

+1.888.681 TIGO (8446)
customer support fax (toll-free in US)

www.tigoenergy.com

+800-CALL-TIGO (2255-8446)
customer support line in Europe

+1.408.358.6279
fax outside the USA

support@tigoenergy.com
Skype: support.tigoenergy

420 Blossom Hill Road
Los Gatos, CA 95032

