











R023_LAVA User Manual

1. For your safety

Before using your phone, please read the following important information to eliminate or reduce any possibility of causing damage and personal injury.

	Do not use wireless phones while driving.
	Switch off wireless devices in aircraft. The signal may cause interference. Using them on aircraft is illegal.
	Do not use mobile phones where blasting is in progress. Follow any regulations and rules strictly.
	Do not use mobile phones at Petrol stations. Don't use near fuel or chemicals. Do not dispose your battery or mobile in a fire.
	Follow any regulations or rules in hospital and health care facilities. Switch phone off near medical equipment.
	All wireless devices may get interference that could affect performance.
	The repair or installation of the device should be done at Authorized service centers
	Use only approved accessories and batteries.
	Use only in normal position. Do not expose your phone to extreme high temperatures above +60°C (+140°F). Do not use anything static to clean your phone.
	Ensure the phone is turned on and in service. Enter the emergency number, then press Pick Up key. Give your location. Do not end the call until told to do so.

Improper use will invalidate the warranty! These safety instructions also apply to original accessories.

2 .Phone Overview

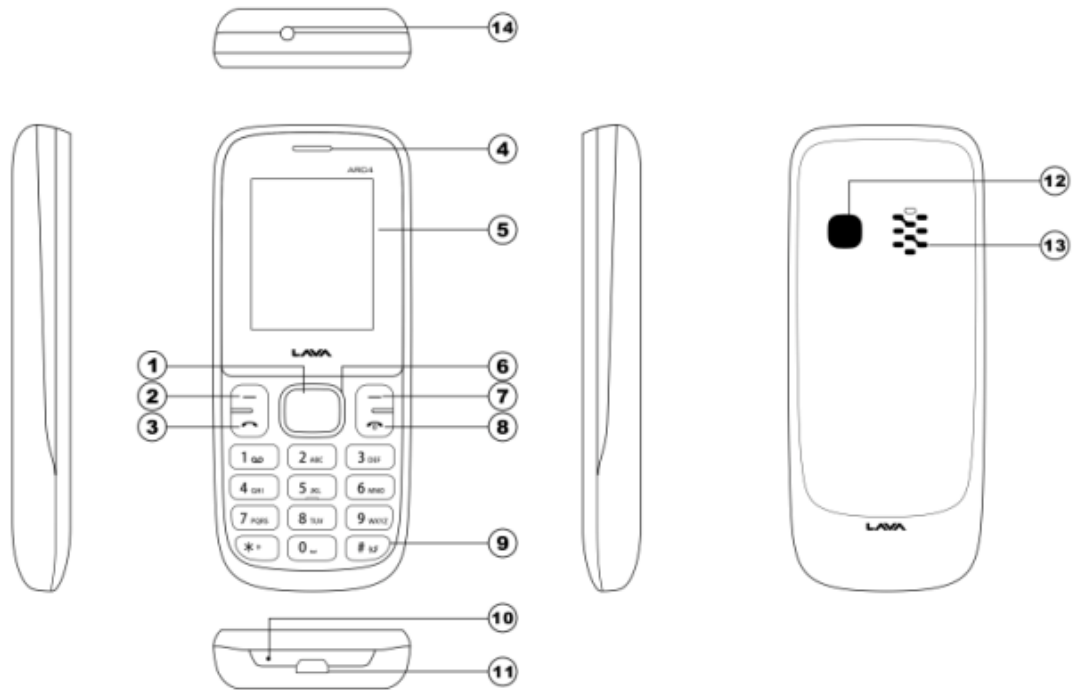

1	Center key	8	Ending/Power key
2	Left soft key	9	Keypad
3	Dial/Answer key	10	Microphone
4	Earpiece	11	Charge/Headset port
5	Display	12	Camera
6	Navigation key	13	Speaker
7	Right soft key	14	Torch

3. Getting started

3.1 Installing the SIM Cards, T-flash card and battery.

SIM card carries useful information, including your mobile phone number, PIN (Personal Identification Number), PUK (PIN Unlocking Key), IMSI (International Mobile Subscriber Identity), network information, contacts data, and short messages data.

- 1) Remove the back cover and lift the battery away.

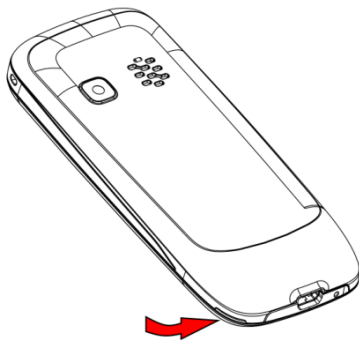

- 2) Insert the SIM card into the SIM card slot lightly with the corner cutting of the card aligning to the notch of the slot and the gold plate of the card facing downward, till the SIM card cannot be further pushed in.

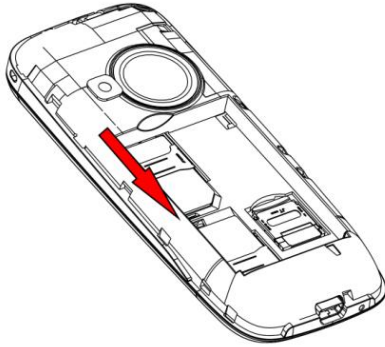

- 3) To install the T-Flash card, open its latch, place its indented side downward, insert the card into the card slot, and then close the latch.

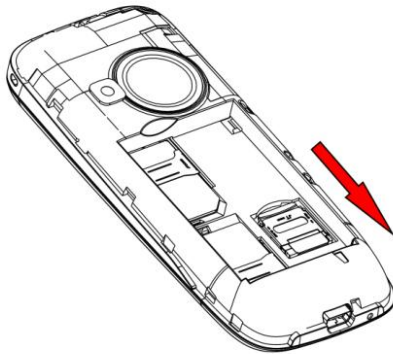

- 4) With the metallic contacts of the battery facing the metallic contacts in the battery slot, press the battery down until it locks into place, then fix its back cover

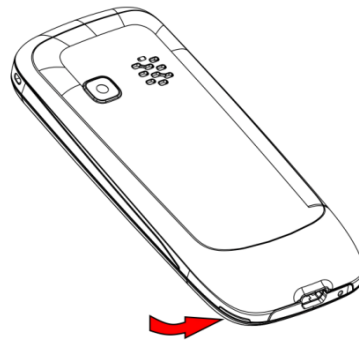
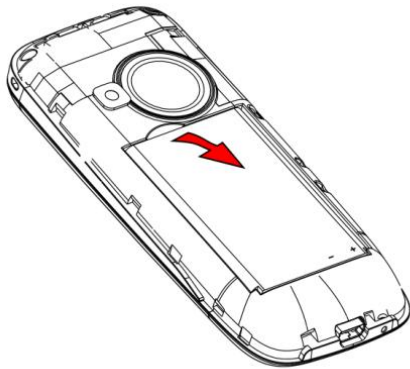

3.2 Linking to the Network

After the SIM card and the mobile phone are successfully unlocked, the mobile phone automatically searches for an available network.

4. Input methods

This mobile phone provides multiple input methods, including India, English input in both upper and lower case, and numeric input method.

- 1) Press # key to switch between input methods.
- 2) Press the * key to enter the Select symbol interface and select a symbol you want.

5. Menus introduction

5.1 File Manager

The phone supports the T-Flash card. You can use the file manager to conveniently manage various directories and files on the T-Flash card.

5.2 Phonebook

The mobile phone can store at least 500 phone numbers.

5.3 Call logs

Call history

Through this function, you can view a list of missed calls, dialed calls and received calls etc.

5.4 Messages

If the short message memory is full, a blinking message icon appears on the top of the screen.

5.5 Multimedia

Camera

Use this function to take picture.

Image viewer

Use this function to preview photos.

Video recorder

Use this function to record video files.

Video player

Use this function to play video files.

Sound recorder

Use this function to record audio files.

FM radio

You can use your phone to listen to FM radio stations once the original Headset is plugged into the connector.

5.6 Organizer

Torch

Select on or off as you per needed. Long press Right soft key to switch on or off in the standby interface.

Calendar

Once you enter this menu, there is a monthly-view calendar for you to view the date; you can go to any day you want.

Alarm

You can activate one, or multiple as needed. For each alarm clock, the ringing date and the ringing time can be set.

World clock

This function allows you to check the standard time in different areas of the world.

Bluetooth

With Bluetooth, you can make a wireless connection to other compatible devices, such as mobile phones, computers, headsets and car kits. You can use the Bluetooth to send images, video clips, music, sound clips and notes, and transfer files from your compatible pc.

Calculator

The calculator can add, subtract, multiply and divide.

Services

STK service is the tool kit of SIM card. This phone supports the service function .The specific items are depended by SIM card and network. Service menu will be auto added to

the phone menu when supported by network and SIM card.

Shortcuts

You can edit shortcut and add shortcut.

5.7 Settings

User profile

The mobile phone has multiple user profiles to suit current environment.

Dual SIM settings

Dual-SIM refers to two SIM card slots, and the two cards can standby at the same time or set one of them to display on the idle screen.

Phone Settings

- 1) **Time & date:** set the date format, the time format, and detail time of the location.
- 2) **Language:** Select the display language for the mobile phone.
- 3) **Pref. input method:** Select preferred input method as needed.
- 4) **Display:** You can set wallpaper, show date and time through this function.
- 5) **Dedicated key:** Customize the shortcut functions of the Up, Down, Left, and Right direction keys.
- 6) **Auto update time**
- 7) **Flight mode:** You can select to turn on normal mode or flight mode.
- 8) **Misc. settings:** LCD backlight setting.

Network selection

Set Network selection mode to Automatic or Manual. Automatic is recommended. When Network selection mode is set to Automatic, the mobile phone will prefer the network where the SIM card is registered. When Network selection mode is set to Manual, you need to select the network operator's network where the SIM card is registered.

Security settings

- 1) **SIM PIN security :** PIN code is the personal identification number for SIM card. If never be modified, the initial password set by network operator should be 1234. If activated the power-on PIN code, then you have to input the PIN password each time you switch the phone on. You can modify the PIN code to prevent your SIM card being used by others.
- 2) **Phone security :** Secured by phone password, the phone will be protected from other unauthorized users. After activated this function, you should input password each time you switch the phone on. The defaulted password is 4321.

Call settings

SIM1 /SIM2 call settings

Here you can do the settings for various functions related to SIM1 and SIM2 calling.

Restore Factory Settings

Use this function to restore factory settings. The preset password is 4321.

5.9 Audio player

Use this function to play audio files.

6. Addendum

Common fault diagnosis

Fault phenomenon	possible reasons
Cannot turn on	The battery is charged with electricity. Battery is correct
Wrong SIM Card	SIM card smudgy, clean the SIM card. Reinstall the SIM card.
	SIM card has been damaged, replace the SIM card.

Reception bad	Check on the screen of the signal strength indicator, and this is the number of symbols in this for 5 case said the strong signal, 2 case said the weak signal
Phone can't dial	you may set the hide the machine number, but your network operator does not provide this service; may have a strong interference environment around signal; may you activate the call barring function; may you activate the line 2, but your network operator does not provide this service ;
Battery can't charge	may have excessive discharge battery, charger needed to connect after a period of time to charge; battery performance have been worse;
Unable to connect to the network	signal is too weak, or around the radio interference SIM card is installed correctly, whether contact undesirable or SIM card has been damaged? Such as the SIM card is damaged, please you consultation network service operators
Photographs too dark	brightness set low; environment light around a dark;
Photographs too vague	Shooting in a state of motion object ; Press the shutter moment cell phone has a slight shaking ; Dark
Photographs have distortion	May be the foreground subject distance lens too close
Can't enter service menu	May be your SIM card does not support services

7. SAR (Specific Absorption Rate) Information

The highest SAR value for this mobile phone is 1.6 W/Kg, in accordance with the requirements of the ICNIRP, which recommended that the limit for exposure to radio waves is 1.6 watts/kilogram(W/kg) averaged over 1 gram of tissue. For more information, please visit our website (www.lavamobiles.com) to query.

Safety precautions:

- Use a wireless hands-free system (Headphone, headset) with a low power Bluetooth emitter
- Make sure the cell phone has a low SAR
- Keep your calls short or send a text message (SMS) instead. This advice applies especially to children, adolescents and pregnant women

- Use cell phone when the signal quality is good
- People having active medical implants should preferably keep the cell phone at least 15cm away from the implant

8. E-waste Disposal Mechanism

'E-waste' means waste electrical and electronic equipment (WEEE). In other words E-waste is a popular, informal name for electronic products nearing the end of their "useful life". For more details about e-waste please refer e-waste rules, 2011 www.moef.nic.in

9. Do's and Don'ts for disposal e-waste

Do's:

- Ensure that an Authorised Person repairs your Lava products
- Call Our Local Authorised Collection Centers to Dispose Lava products
- Always drop your used electronic products, batteries or any accessories thereof after the end of their life at nearest Authorised Collection Point or Collection Center.
- Separate the packaging material according to responsible waste disposal options and sorting for recycling.
- Always remove the battery from the product, when you do not intend to use the product anymore it in future.

Don'ts:

- Do not Dismantle your Lava Product on your own
- Do not give your e-waste to Kabbadi Wala / Scrap Dealer/ Rag Pickers.
- Do not dispose-off the e-waste in landfills
- Never dump E-waste in garbage bins.
- Do not dispose of your product at municipal waste bins or rooms.
- Do not throw used batteries into household waste.
-

Consequences of improper handling and disposal of E-Waste

- Improper disposal of waste prevents natural resources from being re-used.
- Some waste contains hazardous chemicals and if not disposed of properly may release toxins into the soil and water, and also releases greenhouse gases into the environment
- If e-waste is not properly disposed of, it can threat to the health and well-being of humans and animals and it also has adverse effect on the environment.
- Placing of batteries or devices on or in heating devices, such as microwave, ovens, stoves, or radiators and improper disposal of batteries may lead to explosion.
- If the battery terminals are in contact with metal objects, it may cause a fire.

For more details on how to dispose of your Lava products at the end of life, Please refer the list of our Services Centers on Pan India basis on our website www.lavamobiles.com or please view this link for the details of Service Centers

<http://www.lavamobiles.com/support-services>.

10. Troubleshooting

Service Center number

No.:+919560394002

Kindly note please send area code of place through SMS to this No. and in return you will get address of service center nearest to you by SMS

5 Lava warranty certificate

Limited warranty:

LAVA international Ltd. (LAVA) provides limited warranty for your mobile phone and original accessories delivered with your mobile phone (hereinafter referred to as “product”)

The warranty period for the transceiver is one (1) year and for battery, charger and headset is six (6) months from the date of purchase.

LAVA Warranty

Subject to the conditions of this Limited Warranty, LAVA warrants a product to be free from defects in design, material and workmanship at the time of its original purchase by you, and for a subsequent period of one (1) year for transceiver and six (6) months for battery & charger.

You shall have coverage or benefits under this warranty in the event that any of the following conditions are applicable:

- The product has been subjected to abnormal use or conditions, improper storage, exposure to 1.excessive moisture or dampness, exposure to excessive temperature, unauthorized modification, unauthorized repair (including but not limited to use of unauthorized spare parts in repairs),abuse, accidents, Acts of God, spills of food or liquids, improper installation
- You have not notified Lava of the defect in the product during the applicable warranty period.
- The product serial no. code or the accessories date code has been removed, defaced or altered.
- The product has been used with or connected to an accessory (i) Not supplied by Lava or its affiliates, (ii) Not fit for use with the product or (iii) Used otherwise than in manner intended.
- The seals of the product’s battery enclosure have been broken or shown evidence of tempering or the product’s battery has been used in equipment other than that for which it

has been specified usable by LAVA.

- All plastic surfaces and all other externally exposed part that is scratched or damaged due to normal use.

To get maximum of your new product, we recommend you to:

- Read the guidelines for safe and efficient use as mentioned in the manual.
- Read the terms and conditions of your Lava warranty in the manual.
- Keep your original receipt; you will need it for warranty services if asked to produce.
- Present this Lava Warranty Certificate along with original proof of purchase whenever you require any warranty services.

In case Lava product needs service, please visit the nearest Lava service centers given in the service guide. Please visit our Website www.lavamobiles.com for updated list of Authorized Service Centers near to your location.

Important note: for your warranty to be valid, all information on the warranty certificate has to be completed including the stamp from the authorized distributor/retailer.

All warranty information, product features and specifications are subject to change without notice.

IMEI No.
Dealers Stamp
Date of purchase
Model No.