

RabbitCore RCM2200

C-Programmable Module with Ethernet

Getting Started Manual

019-0096 • 050305-G

RabbitCore RCM2200 Getting Started Manual

Part Number 019-0096 • 050305-G • Printed in U.S.A.

©2001–2005 Z-World Inc. • All rights reserved.

Z-World reserves the right to make changes and improvements to its products without providing notice.

Trademarks

Rabbit and Rabbit 2000 are registered trademarks of Rabbit Semiconductor.

RabbitCore is a trademark of Rabbit Semiconductor.

Z-World is a registered trademark of Z-World Inc.

Dynamic C is a registered trademark of Z-World Inc.

Z-World, Inc.

2900 Spafford Street
Davis, California 95616-6800
USA

Telephone: (530) 757-3737
Fax: (530) 757-3792

www.zworld.com

Rabbit Semiconductor

2932 Spafford Street
Davis, California 95616-6800
USA

Telephone: (530) 757-8400
Fax: (530) 757-8402

www.rabbitsemiconductor.com

TABLE OF CONTENTS

Chapter 1. Introduction & Overview	1
1.1 RCM2200 Description	1
1.1.1 Physical & Electrical Specifications	2
1.2 Development Software	3
1.3 How to Use This Manual	3
1.3.1 Additional Product Information	3
1.3.2 Additional Reference Information	3
1.3.3 Using Online Documentation	4
Chapter 2. Getting Started	5
2.1 Development Kit Contents	5
2.2 Prototyping Board	6
2.2.1 Prototyping Board Features	7
2.2.2 Prototyping Board Expansion	8
2.3 Connections	9
2.3.1 Attach Module to Prototyping Board	9
2.3.2 Connect Programming Cable	10
2.3.3 Connect Power	11
2.4 Run a Sample Program	12
2.4.1 Troubleshooting	12
2.5 Where Do I Go From Here?	13
2.5.1 Technical Support	13
Chapter 3. Software Installation & Overview	15
3.1 An Overview of Dynamic C	15
3.2 Installing Dynamic C	17
3.3 Sample Programs	18
3.3.1 Getting to Know the RCM2200	19
3.3.2 Serial Communication	21
3.3.3 Other Sample Programs	22
3.3.4 Sample Program Descriptions	23
3.4 Upgrading Dynamic C	26
3.4.1 Add-On Modules	26

Chapter 4. Using the TCP/IP Features	27
4.1 TCP/IP Connections	27
4.2 Running TCP/IP Sample Programs	29
4.3 IP Addresses Explained.....	31
4.4 How IP Addresses are Used	32
4.5 Dynamically Assigned Internet Addresses	33
4.6 Placing Your Device on the Internet	34
4.7 How to Set IP Addresses in the Sample Programs.....	35
4.8 How to Set Up Your Computer for Direct Connect	36
4.9 Run the PINGME.C Sample Programs	37
4.10 Running More Sample Programs With Direct Connect	37
4.11 Where Do I Go From Here?	38
Notice to Users	39
Index	41
Schematics	43

1. INTRODUCTION & OVERVIEW

The RCM2200 is an advanced module that incorporates the powerful Rabbit 2000® microprocessor, flash memory, SRAM, digital I/O ports, and a 10/100-compatible Ethernet port with a 10Base-T interface, all on a PCB just half the size of a business card.

Throughout this manual, the term RCM2200 refers to the complete series of RCM2200 RabbitCore modules unless other production models are referred to specifically.

1.1 RCM2200 Description

The RCM2200 is a small-footprint module designed for use on a motherboard that supplies power and interface to real-world I/O devices. Its two 26-pin connection headers provide 26 parallel user I/O lines, shared with three serial ports, along with data, address and control lines. A fourth serial port and three additional I/O lines are available on the programming header.

A fully-enabled slave port permits glueless master-slave interface with another Rabbit-based system. The slave port may also be used with non-Rabbit systems, although additional logic may be required.

The RCM2200 is equipped with a 10/100-compatible Ethernet port with a 10Base-T interface, 256K flash memory and 128K static RAM.

There are four production models in the RCM2200 series. Their standard features are summarized in Table 1.

Table 1. RCM2200 Versions

Feature	RCM2200	RCM2210	RCM2250	RCM2260
Microprocessor	Rabbit 2000 running at 22.1 MHz			
Flash Memory	256K	256K	512K	512K
Static RAM	128K	128K	512K	512K
RJ-45 Ethernet Connector, Filter Capacitors, and LEDs	Yes	No	Yes	No
Serial Ports	4, high-speed, CMOS-compatible; 2 configurable as clocked ports; 1 clocked port dedicated to programming port use.			

In addition, a variant of the RCM2200 is available. The RCM2300 omits the Ethernet connectivity but offers a much smaller footprint, one-half the size of the RCM2200.

Another RabbitCore module can be used to reprogram an RCM2200. This reprogramming (and debugging) can be done via the Internet using Z-World’s RabbitLink network programming gateway.

1.1.1 Physical & Electrical Specifications

Table 2 lists the basic specifications for the RCM2200.

Table 2. RCM2200 Specifications

Specification	Data
Power Supply	4.75 – 5.25 V DC (134 mA at 22.1 MHz clock speed)
Size	2.3” x 1.6” x 0.86” (59 mm x 41 mm x 22 mm)
Environmental	–40°C to 70°C, 5–95% humidity, noncondensing

NOTE: For complete product specifications, see Appendix A in the *RabbitCore RCM2200 User’s Manual*.

The RCM2200 modules have two 26-pin headers to which cables can be connected, or which can be plugged into matching sockets on a production device. The pinouts for these connectors are shown in Figure 1 below.

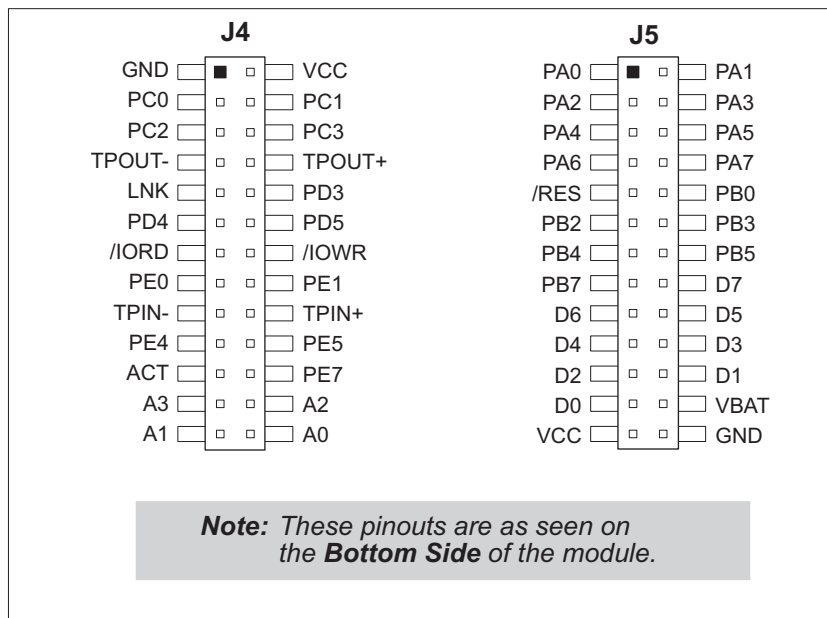

Figure 1. RCM2200 Connector Pinout

1.2 Development Software

The RCM2200 module uses the Dynamic C development environment for rapid creation and debugging of runtime applications. Dynamic C provides a complete development environment with integrated editor, compiler and source-level debugger. It interfaces directly with the target system, eliminating the need for complex and unreliable in-circuit emulators.

Dynamic C must be installed on a Windows workstation with at least one free serial (COM) port for communication with the target system. See Chapter 3., “Software Installation & Overview.” for complete information on installing Dynamic C.

NOTE: The RCM2200 module requires Dynamic C v7.04 or later for development. A compatible version is included on the Development Kit CD-ROM.

1.3 How to Use This Manual

This *Getting Started* manual is intended to give users a quick but solid start with the RCM2200 module. It does not contain detailed information on the module hardware capabilities, the Dynamic C development environment, or the TCP/IP software support for the integrated Ethernet port. Most users will want more detailed information on some or all of these topics in order to put the RCM2200 module to effective use.

1.3.1 Additional Product Information

Detailed information about the RCM2200 will be found in the *RabbitCore RCM2200 User's Manual*, provided on the accompanying CD-ROM in both HTML and Adobe PDF format.

Some advanced users may choose to skip the rest of this introductory manual and proceed directly with the detailed hardware and software information in the User's manual.

TIP: We recommend that anyone not thoroughly familiar with Z-World controllers at least read through the rest of this manual to gain the necessary familiarity to make use of the more advanced information.

1.3.2 Additional Reference Information

In addition to the product-specific information contained in the *RabbitCore RCM2200 User's Manual*, several higher-level reference manuals are provided in HTML and PDF form on the accompanying CD-ROM. Advanced users will find these references valuable in developing systems based on the RCM2200 module:

- *Dynamic C User's Manual*
- *Dynamic C Function Reference Manual*
- *An Introduction to TCP/IP*
- *Dynamic C TCP/IP User's Manual*
- *Rabbit 2000 Microprocessor User's Manual*

1.3.3 Using Online Documentation

We provide the bulk of our user and reference documentation in two electronic formats, HTML and Adobe PDF. We do this for several reasons.

We believe that providing all users with our complete library of product and reference manuals is a useful convenience. However, printed manuals are expensive to print, stock and ship. Rather than include and charge for manuals that every user may not want, or provide only product-specific manuals, we choose to provide our complete documentation and reference library in electronic form with every development kit and with our Dynamic C development environment.

NOTE: The most current version of Adobe Acrobat Reader can always be downloaded from Adobe's web site at <http://www.adobe.com>. We recommend that you use version 4.0 or later.

Providing this documentation in electronic form saves an enormous amount of paper by not printing copies of manuals that users don't need.

Finding Online Documents

The online documentation is installed along with Dynamic C, and an icon for the documentation menu is placed on the workstation's desktop. Double-click this icon to reach the menu. If the icon is missing, create a new desktop icon that points to **default.htm** in the **docs** folder, found in the Dynamic C installation folder.

The latest versions of all documents are always available for free, unregistered download from our web sites as well.

Printing Electronic Manuals

We recognize that many users prefer printed manuals for some uses. Users can easily print all or parts of those manuals provided in electronic form. The following guidelines may be helpful:

- Print from the Adobe PDF versions of the files, not the HTML versions.
- If your printer supports duplex printing, print pages double-sided.
- If you do not have a suitable printer or do not want to print the manual yourself, most retail copy shops (e.g. Kinkos, AlphaGraphics, etc.) will print the manual from the PDF file and bind it for a reasonable charge—about what we would have to charge for a printed and bound manual.

2. GETTING STARTED

This chapter describes the RCM2200 hardware in more detail, and explains how to set up and use the accompanying Prototyping Board.

NOTE: This chapter (and this manual) assume that you have the RCM2200 Development Kit. If you purchased an RCM2200 module by itself, you will have to adapt the information in this chapter and elsewhere to your test and development setup.

2.1 Development Kit Contents

The RCM2200 Development Kit contains the following items:

- RCM2200 module with 10/100-compatible Ethernet port, 256K flash memory, and 128K SRAM.
- RCM2200 Prototyping Board.
- Wall transformer power supply, 12 V DC, 1 A. (Included only with Development Kits sold for the North American market. Overseas users will have to substitute a power supply compatible with local mains power.)
- 10-pin header to DE9 programming cable with integrated level-matching circuitry.
- *Dynamic C* CD-ROM, with complete product documentation on disk.
- This *Getting Started* manual.
- *Rabbit 2000 Processor Easy Reference* poster.
- Registration card.

2.2 Prototyping Board

The Prototyping Board included in the Development Kit makes it easy to connect an RCM2200 module to a power supply and a PC workstation for development. It also provides some basic I/O peripherals (switches and LEDs), as well as a prototyping area for more advanced hardware development.

For the most basic level of evaluation and development, the Prototyping Board can be used without modification.

As you progress to more sophisticated experimentation and hardware development, modifications and additions can be made to the board without modifying or damaging the RCM2200 module itself.

The Prototyping Board is shown below in Figure 2, with its main features identified.

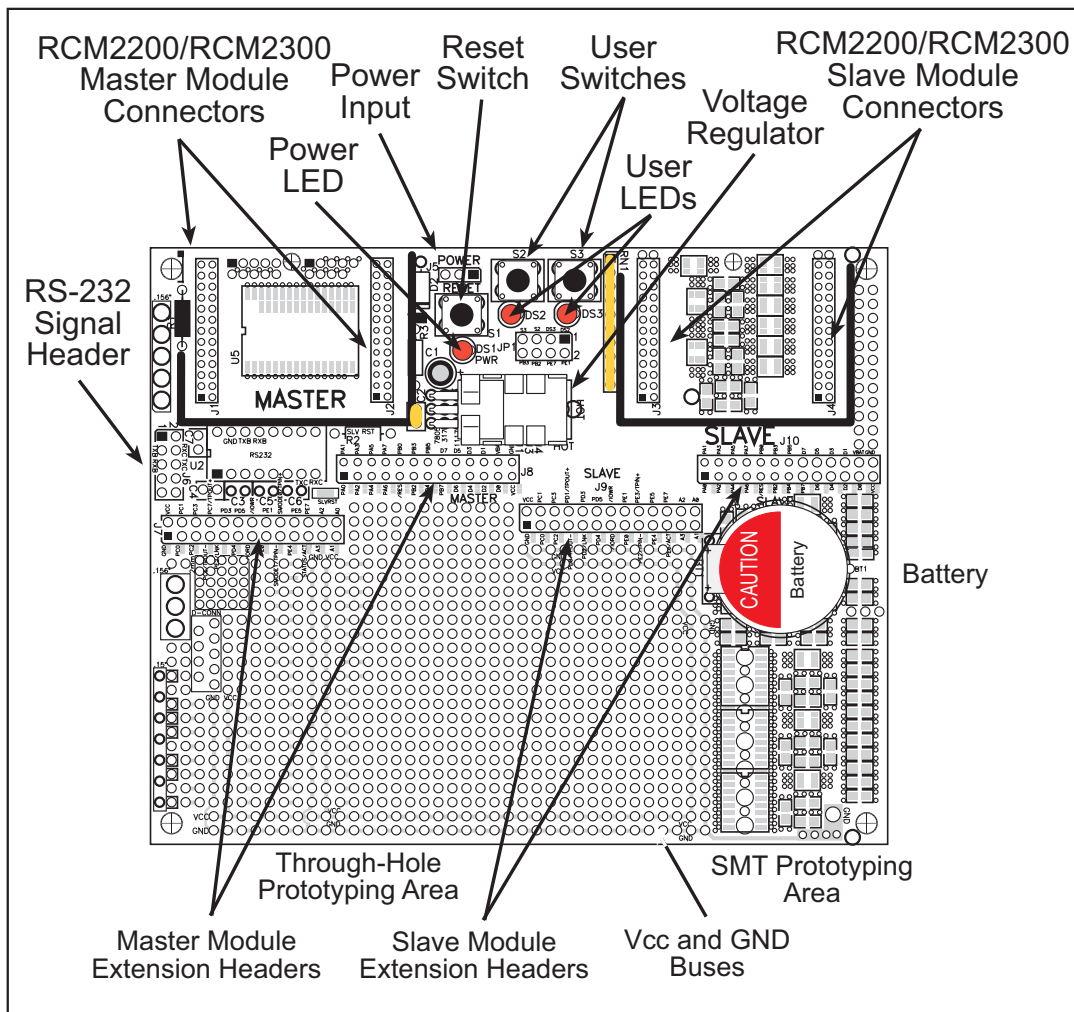

Figure 2. RCM2200/RCM2300 Prototyping Board

2.2.1 Prototyping Board Features

- **Power Connection**—A 3-pin header is provided for connection to the power supply. Note that it is symmetrical, with both outer pins connected to ground and the center pin connected to the raw V+ input. The cable of the wall transformer provided with the North American version of the development kit ends in a connector that is correctly connected in either orientation.

Users providing their own power supply should ensure that it delivers 8–24 V DC at not less than 500 mA. The voltage regulator will get warm while in use. (Lower supply voltages will reduce thermal dissipation from the device.)

- **Regulated Power Supply**—The raw DC voltage provided at the POWER IN jack is routed to a 5 V linear voltage regulator, which provides stable power to the RCM2200 module and the Prototyping Board. A Shottky diode protects the power supply against damage from reversed raw power connections.
- **Power LED**—The power LED lights whenever power is connected to the Prototyping Board.
- **Reset Switch**—A momentary-contact, normally open switch is connected directly to the RCM2200's **/RES** pin. Pressing the switch forces a hardware reset of the system.
- **I/O Switches and LEDs**—Two momentary-contact, normally open switches are connected to the PB2 and PB3 pins of the master RCM2200 module and may be read as inputs by sample applications.

Two LEDs are connected to the PE1 and PE7 pins of the master module, and may be driven as output indicators by sample applications.

The LEDs and switches are connected through JP1, which has traces shorting adjacent pads together. These traces may be cut to disconnect the LEDs, and an 8-pin header soldered into JP1 to permit their selective reconnection with jumpers. See Figure 3 for details.

- **Expansion Areas**—The Prototyping Board is provided with several unpopulated areas for expansion of I/O and interfacing capabilities. See the next section for details.
- **Prototyping Area**—A generous prototyping area has been provided for the installation of through-hole components. Vcc (5 V DC) and Ground buses run around the edge of this area. An area for surface-mount devices is provided to the right of the through-hole area. (Note that there are SMT device pads on both top and bottom of the Prototyping Board.) Each SMT pad is connected to a hole designed to accept a 30 AWG solid wire.
- **Slave Module Connectors**—A second set of connectors is pre-wired to permit installation of a second, slave RCM2200 or RCM2300 module. This capability is reserved for future use, although the schematics in this manual contain all of the details an experienced developer will need to implement a master-slave system.

2.2.2 Prototyping Board Expansion

The Prototyping Board comes with several unpopulated areas, which may be filled with components to suit the user's development needs. After you have experimented with the sample programs in Section 3.3, you may wish to expand the board's capabilities for further experimentation and development. Refer to the Prototyping Board schematic (090–0122) for details as necessary.

- **Module Extension Headers**—The complete pin sets of both the Master and Slave RabbitCore modules are duplicated at these two sets of headers. Developers can solder wires directly into the appropriate holes, or, for more flexible development, 26-pin header strips can be soldered into place. See Figure 1 for the header pinouts.
- **RS-232**—Two 2-wire or one 4-wire RS-232 serial port can be added to the Prototyping Board by installing a driver IC and four capacitors. The Maxim MAX232CPE driver chip or a similar device is recommended for the U2. Refer to the Prototyping Board schematic for additional details.

A 10-pin 0.1-inch spacing header strip can be installed at J6 to permit connection of a ribbon cable leading to a standard DE-9 serial connector.

All RS-232 port components mount to the underside of the Prototyping Board, between the Master module connectors.

NOTE: The RS-232 chip, capacitors and header strip are available from electronics distributors such as Digi-Key.

- **Prototyping Board Component Header**—Four I/O pins from the module are hard-wired to the Prototyping Board LEDs and switches.

To disconnect these devices and permit the pins to be used for other purposes, cut the traces between the pin rows of JP1. Use a knife or similar tool to cut or break the traces crossing JP1 in the area between the silk-screened arrows, as indicated in Figure 3.

Use jumpers across the positions on JP1 if you need to reconnect any of the devices later on.

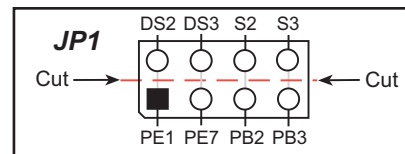

Figure 3. Prototyping Board Header JP1 (located on BOTTOM SIDE of board)

2.3 Connections

There are four steps to connecting the Prototyping Board for use with Dynamic C and the sample programs:

1. Attach the RCM2200 module to the Prototyping Board.
2. Connect the programming cable between the RCM2200 module and the workstation PC.
3. Connect the power supply to the Prototyping Board.

2.3.1 Attach Module to Prototyping Board

Turn the RCM2200 module so that the Ethernet connector end of the module extends off the Prototyping Board, as shown in Figure 4 below. Align the pins from headers J4 and J5 on the bottom side of the RCM2200 with header sockets J1 and J2 on the Prototyping Board.

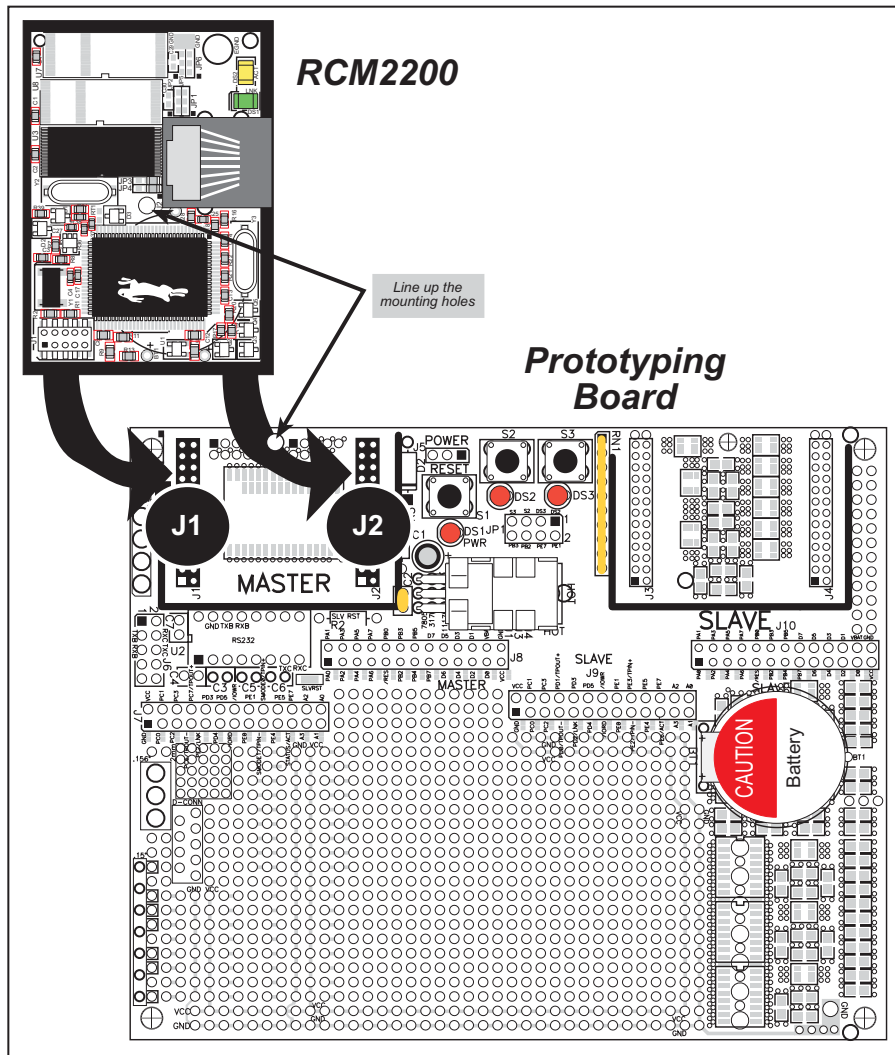

Figure 4. Installing the RCM2200 on the Prototyping Board

Although you can install a single module into either the **MASTER** or the **SLAVE** position on the Prototyping Board, all the Prototyping Board features (switches, LEDs, serial port drivers, etc.) are connected to the **MASTER** position. We recommend you install the module in the **MASTER** position.

NOTE: It is important that you line up the pins on headers J4 and J5 of the RCM2200 exactly with the corresponding pins of header sockets J1 and J2 on the Prototyping Board. The header pins may become bent or damaged if the pin alignment is offset, and the module will not work. Permanent electrical damage to the module may also result if a misaligned module is powered up.

Press the module's pins firmly into the Prototyping Board headers.

2.3.2 Connect Programming Cable

The programming cable connects the RCM2200 module to the PC running Dynamic C to download programs and to monitor the RCM2200 for debugging.

Connect the 10-pin connector of the programming cable labeled **PROG** to header J1 on the RCM2200 module as shown in Figure 5. Be sure to orient the marked (usually red) edge of the cable towards pin 1 of the connector. (Do not use the **DIAG** connector, which is used for a normal serial connection.)

Connect the other end of the programming cable to a COM port on your PC. Make a note of the port to which you connect the cable, as Dynamic C needs to have this parameter configured when it is installed.

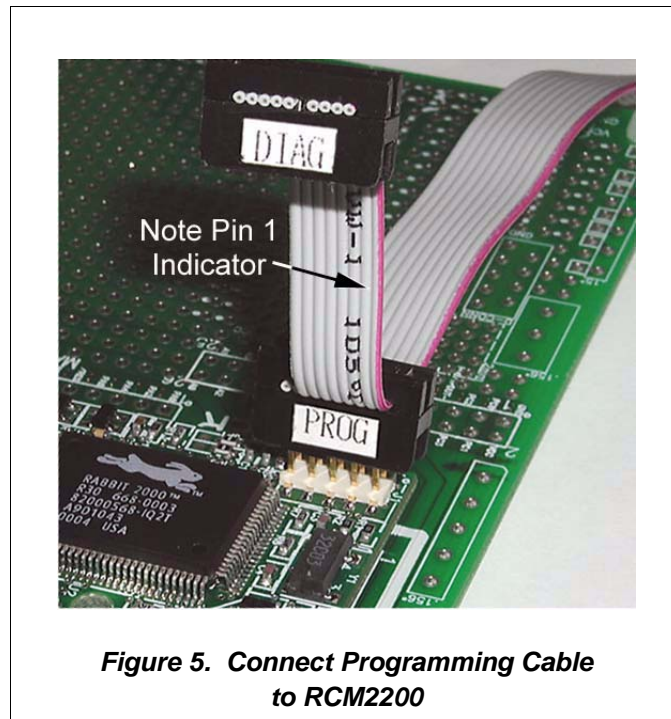

NOTE: COM 1 is the default port used by Dynamic C.

NOTE: Some PCs now come equipped only with a USB port. It may be possible to use an RS-232/USB converter with the programming cable supplied with your RCM2200 module. An RS-232/USB converter is available through the Z-World Web store.

2.3.3 Connect Power

When all other connections have been made, you can connect power to the RCM2200 Prototyping Board.

Hook the connector from the wall transformer to header J5 on the Prototyping Board as shown in Figure 6 below. The connector may be attached either way as long as it is not offset to one side.

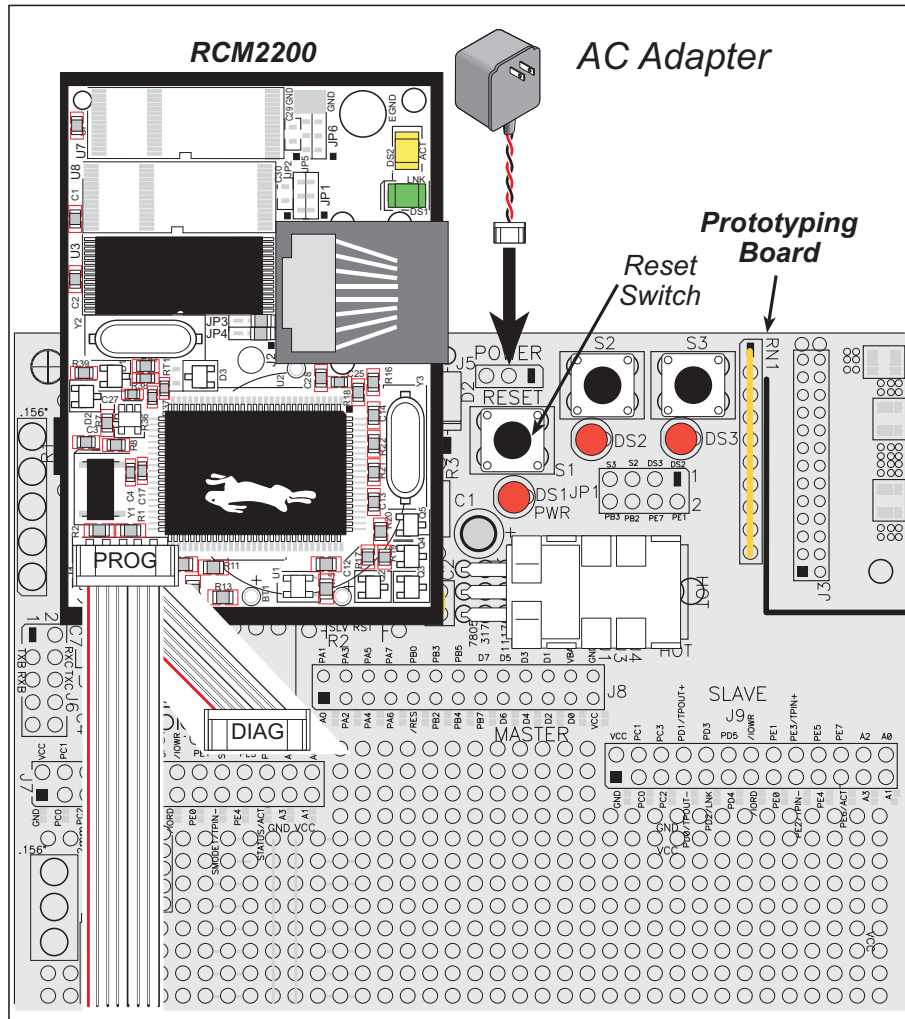

Figure 6. Power Supply Connections

Plug in the wall transformer. The power LED on the Prototyping Board should light up. The RCM2200 and the Prototyping Board are now ready to be used.

NOTE: A **RESET** button is provided on the Prototyping Board to allow hardware reset without disconnecting power.

To power down the Prototyping Board, unplug the power connector from J5. You should disconnect power before making any circuit adjustments in the prototyping area, changing any connections to the board, or removing the RabbitCore module from the board.

2.4 Run a Sample Program

If you already have Dynamic C installed, you are now ready to test your programming connections by running a sample program.

If you are using a USB port to connect your computer to the RCM2200 module, choose **Options > Project Options** and select “Use USB to Serial Converter” under the **Communications** tab.

Find the file **PONG.C**, which is in the Dynamic C **SAMPLES** folder. To run the program, open it with the **File** menu (if it is not still open), then compile and run it by pressing **F9** or by selecting **Run** in the **Run** menu. The **STDIO** window will open and will display a small square bouncing around in a box.

2.4.1 Troubleshooting

If a program compiles and loads, but then loses target communication before you can begin debugging, it is possible that your PC cannot handle the default debugging baud rate. Try lowering the debugging baud rate as follows.

- Locate the **Serial Options** dialog in the Dynamic C **Options > Project Options > Communications** menu. Choose a lower debug baud rate.

If there are any other problems:

- Check to make sure you are using the **PROG** connector, not the **DIAG** connector, on the programming cable.
- Check both ends of the programming cable to ensure that they are firmly plugged into the PC and the programming port on the RCM2200.
- Ensure that the RCM2200 module is firmly and correctly installed in its connectors on the Prototyping Board.
- Select a different COM port within Dynamic C. From the **Options** menu, select **Project Options**, then select **Communications**. Select another COM port from the list, then click OK. Press **<Ctrl-Y>** to force Dynamic C to recompile the BIOS. If Dynamic C still reports it is unable to locate the target system, repeat the above steps until you locate the active COM port.

2.5 Where Do I Go From Here?

If everything appears to be working, we recommend the following sequence of action:

1. Run all of the sample programs described in Chapter 3 to get a basic familiarity with Dynamic C and the RCM2200 module's capabilities.
2. For further development, refer to the *RabbitCore RCM2200 User's Manual* for details of the module's hardware and software components.

A documentation icon should have been installed on your workstation's desktop; click on it to reach the documentation menu. You can create a new desktop icon that points to **default.htm** in the **docs** folder in the Dynamic C installation folder.

3. For advanced development topics, refer to the *Dynamic C User's Manual* and the *Dynamic C TCP/IP User's Manual*, also in the online documentation set.

2.5.1 Technical Support

NOTE: If you purchased your RCM2200 through a distributor or through a Z-World or Rabbit Semiconductor partner, contact the distributor or Z-World partner first for technical support.

If there are any problems at this point:

- Use the Dynamic C **Help** menu to get further assistance with Dynamic C.
- Check the Z-World/Rabbit Semiconductor Technical Bulletin Board at www.zworld.com/support/bb/.
- Use the Technical Support e-mail form at www.zworld.com/support/questionSubmit.shtml.

3. SOFTWARE INSTALLATION & OVERVIEW

To develop and debug programs for the RCM2200 (and for all other Z-World and Rabbit Semiconductor hardware), you must install and use Dynamic C. Dynamic C is an integrated development system for writing embedded software. It runs on an IBM-compatible PC and is designed for use with Z-World single-board computers and other single-board computers based on the Rabbit microprocessor. This chapter takes you through the installation of Dynamic C, and then provides a tour of the sample programs for the RCM2200.

3.1 An Overview of Dynamic C

Dynamic C has been in use worldwide since 1989. It is specially designed for programming embedded systems, and features quick compile and interactive debugging. A complete reference guide to Dynamic C is contained in the *Dynamic C User's Manual*.

You have a choice of doing your software development in the flash memory or in the SRAM included on the RCM2200. The flash memory and SRAM options are selected with the **Options > Project Options > Compiler** menu.

The advantage of working in RAM is to save wear on the flash memory, which is limited to about 100,000 write cycles. The disadvantage is that the code and data might not both fit in RAM.

NOTE: An application can be developed in RAM, but cannot run standalone from RAM after the programming cable is disconnected. All standalone applications can only run from flash memory.

NOTE: Do not depend on the flash memory sector size or type. Due to the volatility of the flash memory market, the RCM2200 and Dynamic C were designed to accommodate flash devices with various sector sizes.

Developing software with Dynamic C is simple. Users can write, compile, and test C and assembly code without leaving the Dynamic C development environment. Debugging occurs while the application runs on the target. Alternatively, users can compile a program to an image file for later loading. Dynamic C runs on PCs under Windows 95, 98, 2000, NT, Me, and XP. Programs can be downloaded at baud rates of up to 460,800 bps after the program compiles.

Dynamic C has a number of standard features.

- Full-feature source and/or assembly-level debugger, no in-circuit emulator required.
- Royalty-free TCP/IP stack with source code and most common protocols.
- Hundreds of functions in source-code libraries and sample programs:
 - ▶ Exceptionally fast support for floating-point arithmetic and transcendental functions.
 - ▶ RS-232 and RS-485 serial communication.
 - ▶ Analog and digital I/O drivers.
 - ▶ I²C, SPI, GPS, file system.
 - ▶ LCD display and keypad drivers.
- Powerful language extensions for cooperative or preemptive multitasking
- Loader utility program to load binary images into Z-World targets in the absence of Dynamic C.
- Provision for customers to create their own source code libraries and augment on-line help by creating “function description” block comments using a special format for library functions.
- Standard debugging features:
 - ▶ Breakpoints—Set breakpoints that can disable interrupts.
 - ▶ Single-stepping—Step into or over functions at a source or machine code level, μ C/OS-II aware.
 - ▶ Code disassembly—The disassembly window displays addresses, opcodes, mnemonics, and machine cycle times. Switch between debugging at machine-code level and source-code level by simply opening or closing the disassembly window.
 - ▶ Watch expressions—Watch expressions are compiled when defined, so complex expressions including function calls may be placed into watch expressions. Watch expressions can be updated with or without stopping program execution.
 - ▶ Register window—All processor registers and flags are displayed. The contents of general registers may be modified in the window by the user.
 - ▶ Stack window—shows the contents of the top of the stack.
 - ▶ Hex memory dump—displays the contents of memory at any address.
 - ▶ **STDIO** window—`printf` outputs to this window and keyboard input on the host PC can be detected for debugging purposes. `printf` output may also be sent to a serial port or file.

3.2 Installing Dynamic C

Insert the Dynamic C CD from the Development Kit in your PC's CD-ROM drive. If the installation does not auto-start, run the `setup.exe` program in the root directory of the Dynamic C CD. Install any Dynamic C modules after you install Dynamic C.

Dynamic C has two components that can be installed together or separately. One component is Dynamic C itself, with the development environment, support files and libraries. The other component is the documentation library in HTML and PDF formats, which may be left uninstalled to save hard drive space or installed elsewhere (on a separate or network drive, for example).

The installation type is selected in the installation menu shown above. The options are:

- **Typical Installation** — Both Dynamic C and the documentation library will be installed in the specified folder (default).
- **Compact Installation** — Only Dynamic C will be installed.
- **Custom Installation** — You will be allowed to choose which components are installed. This choice is useful to install or reinstall just the documentation.

3.3 Sample Programs

To help familiarize you with the RCM2200 modules, several sample Dynamic C programs have been included. Loading, executing and studying these programs will give you a solid hands-on overview of the RCM2200's capabilities, as well as a quick start with Dynamic C as an application development tool. These programs are intended to serve as tutorials, but then can also be used as starting points or building blocks for your own applications.

NOTE: It is assumed in this section that you have at least an elementary grasp of ANSI C. If you do not, see the introductory pages of the *Dynamic C User's Manual* for a suggested reading list.

Each sample program has comments that describe the purpose and function of the program.

Before running any of these sample program, make sure that your RCM2200 is connected to the Prototyping Board and to your PC as described in Section 2.3, "Connections."

To run a sample program, open it with the **File** menu (if it is not already open), then compile and run it by pressing **F9** or by selecting **Run** in the **Run** menu.

More complete information on Dynamic C is provided in the *Dynamic C User's Manual*.

3.3.1 Getting to Know the RCM2200

The following sample programs can be found in the `SAMPLES\RCM2200` folder.

- **EXTSRAM.C**—demonstrates the setup and simple addressing to an external SRAM. This program first maps the external SRAM to the I/O Bank 7 register with a maximum of 15 wait states, chip select strobe (PE7), and allows writes. The first 256 bytes of SRAM are cleared and read back. Values are then written to the same area and are read back. The Dynamic C **STDIO** window will indicate if writes and reads did not occur

Connect an external SRAM as shown below before you run this sample program.

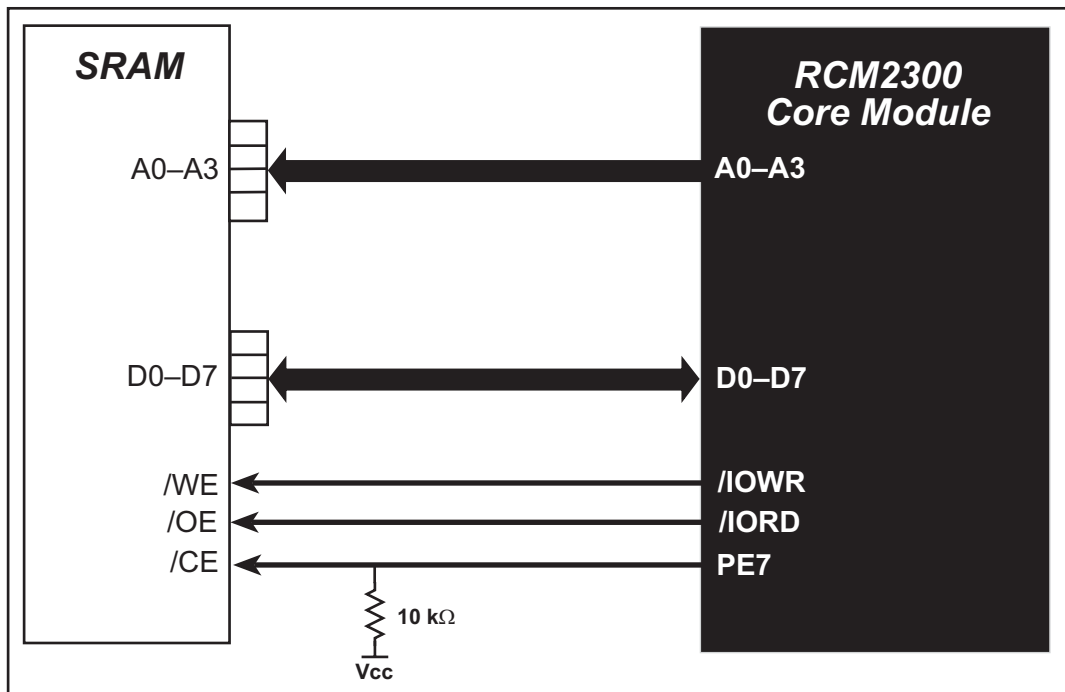

- **FLASHLED.C**—repeatedly flashes LED DS3 on the Prototyping Board on and off. LED DS3 is controlled by Parallel Port E bit 7 (PE7). LED DS2 will remain on continuously.
- **FLASHLEDS.C**—demonstrates the use of coding with assembly instructions, cofunctions, and costatements to flash LEDs DS2 and DS3 on the Prototyping Board on and off. LEDs DS2 and DS3 are controlled by Parallel Port E bit 1 (PE1) and Parallel Port E bit 7 (PE7). Once you have compiled this program and it is running, LEDs DS2 and DS3 will flash on/off at different rates.
- **TOGGLELED.C**—demonstrates the use of costatements to detect switch presses using the press-and-release method of debouncing. As soon as the sample program starts running, LED DS2 on the Prototyping Board (which is controlled by PE1) starts flashing once per second. Press switch S3 on the Prototyping Board (which is connected to PB3) to toggle LED DS3 on the Prototyping Board (which is controlled by PE7) on and off. The pushbutton switch is debounced by the software.

- **KEYLCD.C**—demonstrates a simple setup for a 2 × 6 keypad and a 2 × 20 LCD.

Connect the keypad to Parallel Ports B, C, and D.

- PB0—Keypad Col 0
- PC1—Keypad Col 1
- PB2—Keypad Col 2
- PB3—Keypad Col 3
- PB4—Keypad Col 4
- PB5—Keypad Col 5
- PD3—Keypad Row 0
- PD4—Keypad Row 1

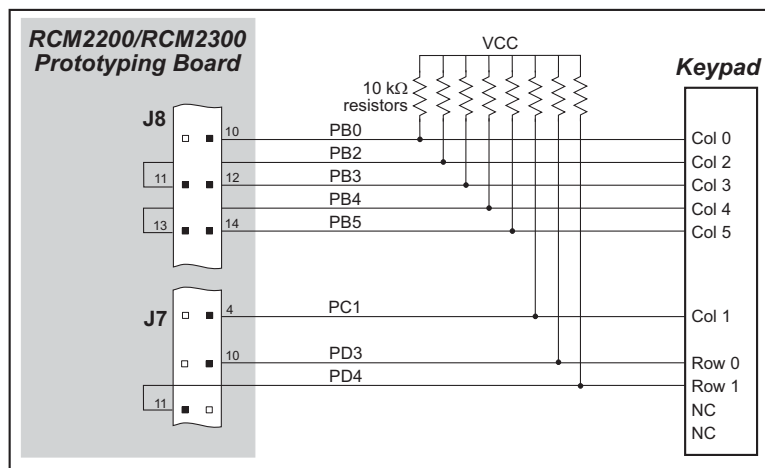

Connect the LCD to Parallel Port A.

- PA0—backlight (if connected)
- PA1—LCD /CS
- PA2—LCD RS (High = Control, Low = Data) / LCD Contrast 0
- PA3—LCD /WR / LCD Contrast 1
- PA4—LCD D4 / LCD Contrast 2
- PA5—LCD D5 / LCD Contrast 3
- PA6—LCD D6 / LCD Contrast 4
- PA7—LCD D7 / LCD Contrast 5

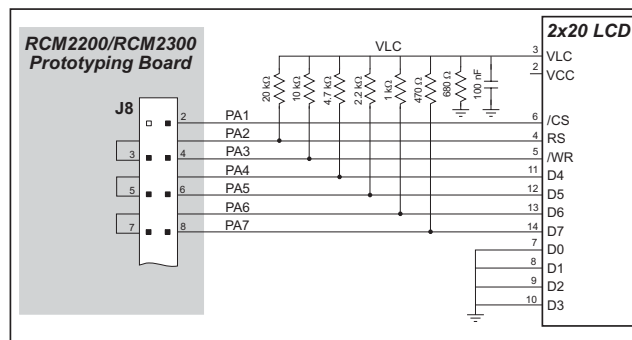

Once the connections have been made and the sample program is running, the LCD will display two rows of 6 dots, each dot representing the corresponding key. When a key is pressed, the corresponding dot will become an asterisk.

3.3.2 Serial Communication

The following sample programs can be found in the **SAMPLES\RCM2200** folder.

One sample programs, **PUTS.C** is available to illustrate RS-232 communication. To run this sample program, you will have to add an RS-232 transceiver such as the MAX232 at location U2 and five 100 nF capacitors at C3–C7 on the Prototyping Board. Also install a 2 × 5 IDC header with a pitch of 0.1" at J6 to interface the RS-232 signals. The diagram shows the connections.

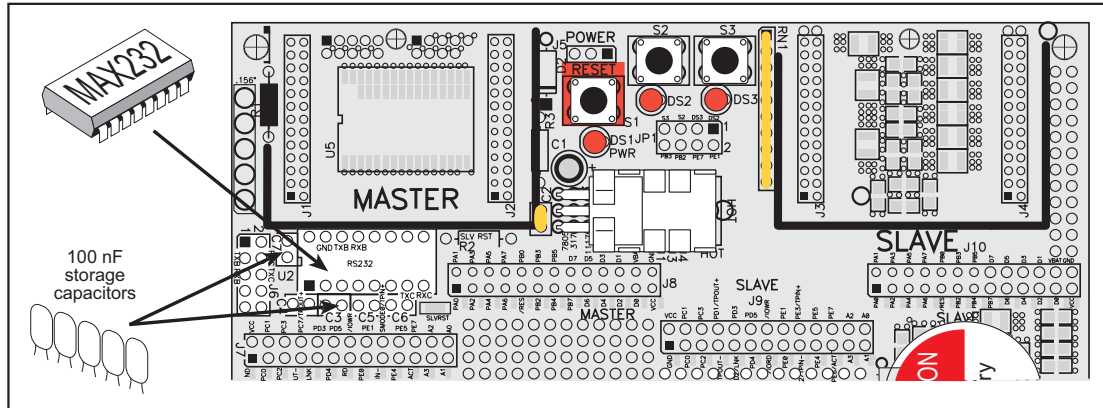

Once the sample program is running, you may use a 10-pin header to DE9 cable (for example, Z-World part number 540-0009) to connect header J6 to your PC COM port (you will have to disconnect the programming cable from both the RCM2200 and the PC if you only have one PC COM port, then press the **RESET** button on the Prototyping Board). Line up the colored edge of the cable with pin 1 on header J6 as shown in the diagram (pin 1 is indicated by a small square on the Prototyping Board silkscreen).

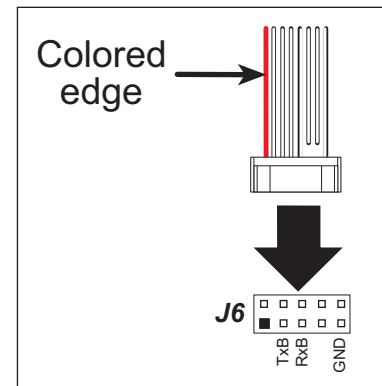

This program writes a null terminated string over Serial Port B. Use a serial utility such as HyperTerminal or Tera Term to view the string. Use the following configuration for your serial utility.

- Bits per second: 19200
- Data bits: 8
- Parity: None
- Stop bits: 1
- Flow control: None

Two sample programs, **MASTER.C** and **SLAVE.C**, are available to illustrate RS-485 master/slave communication. To run these sample programs, you will need a second Rabbit-based system with RS-485, and you will also have to add an RS-485 transceiver such as the SP483E and bias resistors to the Prototyping Board.

The diagram shows the connections. You will have to connect PC0 and PC1 (Serial Port D) on the Prototyping Board to the RS-485 transceiver, and you will connect PD3 to the RS-485 transceiver to enable or disable the RS-485 transmitter.

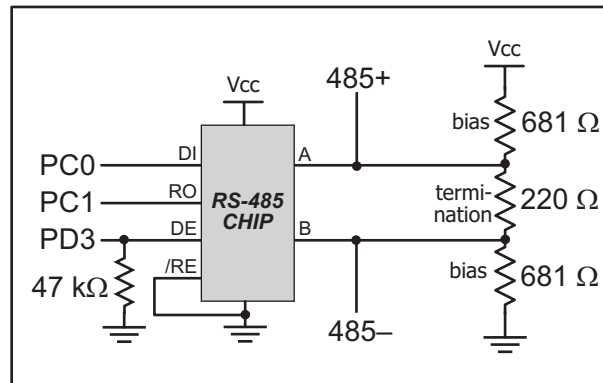

The RS-485 connections between the slave and master devices are as follows.

- RS485+ to RS485+
- RS485- to RS485-
- GND to GND
- **MASTER.C**—This program demonstrates a simple RS-485 transmission of lower case letters to a slave RCM2200. The slave will send back converted upper case letters back to the master RCM2200 and display them in the **STDIO** window. Use **SLAVE.C** to program the slave RCM2200—reset the slave before you run **MASTER.C** on the master.
- **SLAVE.C**—This program demonstrates a simple RS-485 transmission of lower case letters to a master RCM2200. The slave will send back converted upper case letters back to the master RCM2200 and display them in the **STDIO** window. Compile and run this program on the slave before you use **MASTER.C** to program the master.

3.3.3 Other Sample Programs

Section 4.2 covers how to run the TCP/IP sample programs, which are then described in detail.

3.3.4 Sample Program Descriptions

3.3.4.1 FLASHLED.C

This program is about as simple as a Dynamic C application can get—the equivalent of the traditional “Hello, world!” program found in most basic programming tutorials. If you are familiar with ANSI C, you should have no trouble reading through the source code and understanding it.

The only new element in this sample application should be Dynamic C’s handling of the Rabbit microprocessor’s parallel ports. The program:

4. Initializes the pins of Port A as outputs.
5. Sets all of the pins of Port A high, turning off the attached LEDs.
6. Starts an endless loop with a `for (; ;)` expression, and within that loop:
 - Writes a bit to turn bit 1 off, lighting LED DS3;
 - Waits through a delay loop;
 - Writes a bit to turn bit 1 on, turning off the LED;
 - Waits through a second delay loop;

These steps repeat as long as the program is allowed to run.

You can change the flash rate of the LED by adjusting the loop values in the two `for` expressions. The first loop controls the LED’s “off” time; the second loop controls its “on” time.

NOTE: Since the variable `j` is defined as type `int`, the range for `j` must be between 0 and 32767. To permit larger values and thus longer delays, change the declaration of `j` to `unsigned int` or `long`.

More Information

See the section on primitive data types, and the entries for the library functions `WrPortI ()` and `BitWrPortI ()` in the *Dynamic C User’s Manual*.

3.3.4.2 FLASHLEDS.C

In addition to Dynamic C's implementation of C-language programming for embedded systems, it supports assembly-language programming for very efficient processor-level control of the module hardware and program flow. This application is similar to **FLASHLED.C** and **TOGGLELED.C**, but uses assembly language for the low-level port control within *cofunctions*, another powerful multitasking tool.

Dynamic C permits the use of assembly language statements within C code. This program creates three functions using assembly language statements, then creates a C cofunction to call two of them. That cofunction is then called within **main()**.

Within each of the C-like functions, the **#asm** and **#endasm** directives are used to indicate the beginning and end of the assembly language statements.

In the function **initialize_ports()**, port A is initialized to be all outputs while bit 0 of port E is initialized to be an output.

In the function **ledon()**, a 0 is written to the port A bit corresponding to the desired LED (0, which equals DS3, or 1 which equals DS4), turning that LED on. The **ledoff()** function works exactly the same way except that a 1 is written to the bit, turning the selected LED off.

Finally, in the cofunction **flashled()**, the LED to be flashed, the on time in milliseconds, and the off time in milliseconds are passed as arguments. This function uses an endless **for(;;)** loop to call the **ledon()** and **ledoff()** functions, separated by calls to the wait function **DelayMs()**. This sequence will make the indicated LED flash on and off.

As is proper in C program design, the contents of **main()** are almost trivial. The program first calls **initialize_ports()**, then begins an endless **for(;;)** loop. Within this loop, the program:

1. Calls the library function **hitwd()**, which resets the microprocessor's watchdog timer. (If the watchdog timer is not reset every so often, it will force a hard reset of the system. The purpose is to keep an intermittent program or hardware fault from locking up the system. Normally, this function is taken care of by the virtual driver, but it is called explicitly here).
2. Sets up a costatement which calls two instances of the **flashled()** function, one for each LED. Note that one LED is flashed one second on, one-half second (500 ms) off, while the other is flashed in the reverse pattern.

Note also the **wfd** keyword in the costatement. This keyword (an abbreviation for **wait-fordone**, which can also be used) must be used when calling cofunctions. For a complete explanation, see Section 5 and 6 in the *Dynamic C User's Manual*.

More Information

See the entries for the **hitwd()** and **DelayMs()** functions in the *Dynamic C User's Manual*, as well as those for the directives **#asm** and **#endasm**. For a complete explana-

tion of how Dynamic C handles multitasking with costatements and cofunctions, see Chapter 5, “Multitasking with Dynamic C,” and Chapter 6, “The Virtual Driver,” in the *Dynamic C User’s Manual*.

3.3.4.3 TOGGLELED.C

One of Dynamic C’s unique and powerful aspects is its ability to efficiently multitask using *cofunctions* and *costatements*. This simple application demonstrates how these program elements work.

This sample program uses two costatements to set up and manage the two tasks. Costatements must be contained in a loop that will “tap” each of them at regular intervals. This program:

1. Initializes the pins of Port A as outputs.
2. Sets all the pins of Port A high, turning off the attached LEDs.
3. Sets the toggled LED status variable `vswitch` to 0 (LED off).
4. Starts an endless loop using a `while (1)` expression, and within that loop:
 - Executes a costatement that flashes LED DS3;
 - Executes a costatement that checks the state of switch S2 and toggles the state of `vswitch` if it is pressed;
 - Turns LED DS2 on or off, according to the state of `vswitch`.

These steps repeat as long as the program is allowed to run.

The first costatement is a compressed version of `FLASHLED.c`, with slightly different flash timing. It also uses the library function `DelayMs ()` to deliver more accurate timing than the simple delay loops of the previous program.

The second costatement does more than check the status of S2. Switch contacts often “bounce” open and closed several times when the switch is actuated, and each bounce can be interpreted by fast digital logic as an independent press. To clean up this input, the code in the second costatement “debounces” the switch signal by waiting 50 milliseconds and checking the state of the switch again. If it is detected as being closed both times, the program considers it a valid switch press and toggles `vswitch`.

Unlike most C statements, the two costatements are not executed in their entirety on each iteration of the `while (1)` loop. Instead, the list of statements within each costatement is initiated on the first loop, and then executed one “slice” at a time on each successive iteration. This mode of operation is known as a *state machine*, a powerful concept that permits a single processor to efficiently handle a number of independent tasks.

The ability of Dynamic C to manage state machine programs enables you to create very powerful and efficient embedded systems with much greater ease than other programming methods.

More Information

See the entries for the `DelayMs ()` function, as well as Section 5, “Multitasking with Dynamic C,” in the *Dynamic C User’s Manual*.

3.4 Upgrading Dynamic C

Dynamic C patches that focus on bug fixes are available from time to time. Check the Web sites

- www.zworld.com/support/

or

- www.rabbitsemiconductor.com/support/

for the latest patches, workarounds, and bug fixes.

3.4.1 Add-On Modules

Dynamic C installations are designed for use with the board they are included with, and are included at no charge as part of our low-cost kits. Z-World offers add-on Dynamic C modules for purchase, including the popular μ C/OS-II real-time operating system, as well as PPP, Advanced Encryption Standard (AES), and other select libraries.

In addition to the Web-based technical support included at no extra charge, a one-year telephone-based technical support module is also available for purchase.

4. USING THE TCP/IP FEATURES

4.1 TCP/IP Connections

Programming and development can be done with the RCM2200 RabbitCore modules without connecting the Ethernet port to a network. However, if you will be running the sample programs that use the Ethernet capability or will be doing Ethernet-enabled development, you should connect the RCM2200 module's Ethernet port at this time.

Before proceeding you will need to have the following items.

- If you don't have Ethernet access, you will need at least a 10Base-T Ethernet card (available from your favorite computer supplier) installed in a PC.
- Two RJ-45 straight through Ethernet cables and a hub, or an RJ-45 crossover Ethernet cable.

The Ethernet cables and Ethernet hub are available from Z-World in a TCP/IP tool kit. More information is available at www.zworld.com.

1. Connect the AC adapter and the programming cable as shown in Chapter 2, "Getting Started."
2. Ethernet Connections

There are four options for connecting the RCM2200 module to a network for development and runtime purposes. The first two options permit total freedom in selecting network addresses and use of the "network," as no action can interfere with other users. We recommend one of these options for initial development.

- **No LAN** — The simplest alternative for desktop development. Connect the RCM2200's Ethernet port directly to the PC's network interface card using an RJ-45 *crossover cable*. A crossover cable is a special cable that flips some connections between the two connectors and permits direct connection of two client systems. A standard RJ-45 network cable will not work for this purpose.
- **Micro-LAN** — Another simple alternative for desktop development. Use a small Ethernet 10Base-T hub and connect both the PC's network interface card and the RCM2200's Ethernet port to it, using standard network cables.

The following options require more care in address selection and testing actions, as conflicts with other users, servers and systems can occur:

- **LAN** — Connect the RCM2200's Ethernet port to an existing LAN, preferably one to which the development PC is already connected. You will need to obtain IP addressing information from your network administrator.
- **WAN** — The RCM2200 is capable of direct connection to the Internet and other Wide Area Networks, but exceptional care should be used with IP address settings and all network-related programming and development. We recommend that development and debugging be done on a local network before connecting a RabbitCore system to the Internet.

TIP: Checking and debugging the initial setup on a micro-LAN is recommended before connecting the system to a LAN or WAN.

The PC running Dynamic C through the serial port on the RCM2200 does not need to be the PC with the Ethernet card.

3. Apply Power

Plug in the AC adapter. The RCM2200 is now ready to be used.

4.2 Running TCP/IP Sample Programs

We have provided a number of sample programs demonstrating various uses of TCP/IP for networking embedded systems. These programs require that the user connect his PC and the RCM2200 board together on the same network. This network can be a local private network (preferred for initial experimentation and debugging), or a connection via the Internet.

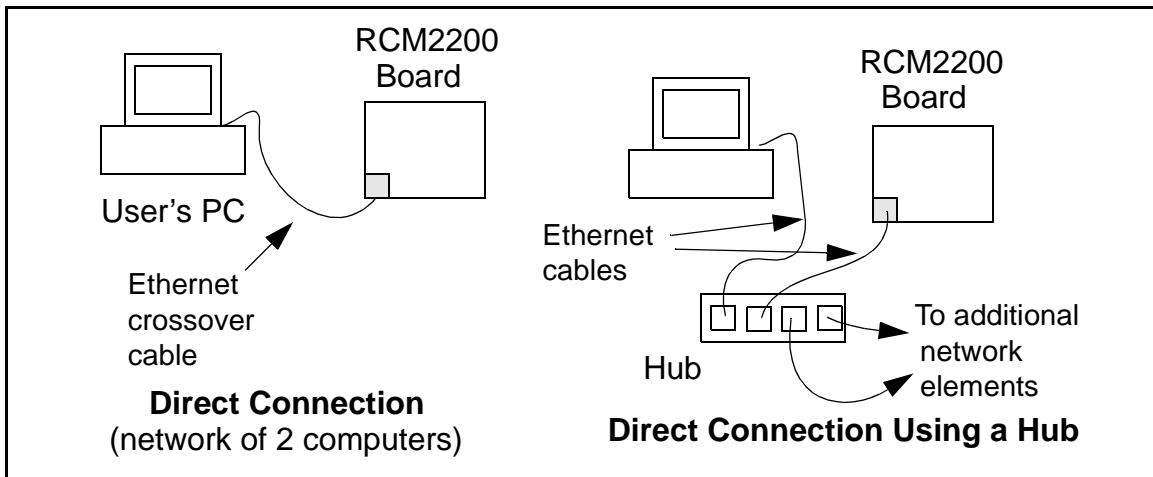

Obtaining IP addresses to interact over an existing, operating, network can involve a number of complications, and must usually be done with cooperation from your ISP and/or network systems administrator (if your company has one). For this reason, it is suggested that the user begin instead by using a direct connection between a PC and the RCM2200 board using an Ethernet crossover cable or a simple arrangement with a hub. (A crossover cable should not be confused with regular straight through cables.) The hub and a wide variety of cables can also be purchased from a local computer store.

In order to set up this direct connection, the user will have to use a PC without networking, or disconnect a PC from the corporate network, or install a second Ethernet adapter and set up a separate private network attached to the second Ethernet adapter. Disconnecting your PC from the corporate network may be easy or nearly impossible, depending on how it is set up. Mobile PCs, such as laptops, are designed to be connected and disconnected, and will present the least problem. If your PC boots from the network or is dependent on the network for some or all of its disks, then it probably should not be disconnected. If a second Ethernet adapter is used, be aware that Windows TCP/IP will send messages to one adapter or the other, depending on the IP address and the binding order in Microsoft products. Thus you should have different ranges of IP addresses on your private network from those used on the corporate network. If both networks service the same IP address, then Windows may send a packet intended for your private network to the corporate network. A similar situation will take place if you use a dial-up line to send a packet to the Internet. Windows may try to send it via the local Ethernet network if it is also valid for that network.

The following IP addresses are set aside for local networks and are not allowed on the Internet: 10.0.0.0 to 10.255.255.255, 172.16.0.0 to 172.31.255.255, and 192.168.0.0 to 192.168.255.255.

The RCM2200 board uses a 10Base-T type of Ethernet connection, which is the most common scheme. The RJ-45 connectors are similar to U.S. style telephone connectors, except they are larger and have 8 contacts.

An alternative to the direct connection using a crossover cable is a direct connection using a hub. The hub relays packets received on any port to all of the ports on the hub. Hubs are low in cost and are readily available. The RCM2200 board uses 10 Mbps Ethernet, so the hub or Ethernet adapter must be either a 10 Mbps unit or a 10/100 unit that adapts to either 10 or 100 Mbps.

In a corporate setting where the Internet is brought in via a high-speed line, there are typically machines between the outside Internet and the internal network. These machines include a combination of proxy servers and firewalls that filter and multiplex Internet traffic. In the configuration below, the RCM2200 board could be given a fixed address so any of the computers on the local network would be able to contact it. It may be possible to configure the firewall or proxy server to allow hosts on the Internet to directly contact the controller, but it would probably be easier to place the controller directly on the external network outside of the firewall. This avoids some of the configuration complications by sacrificing some security.

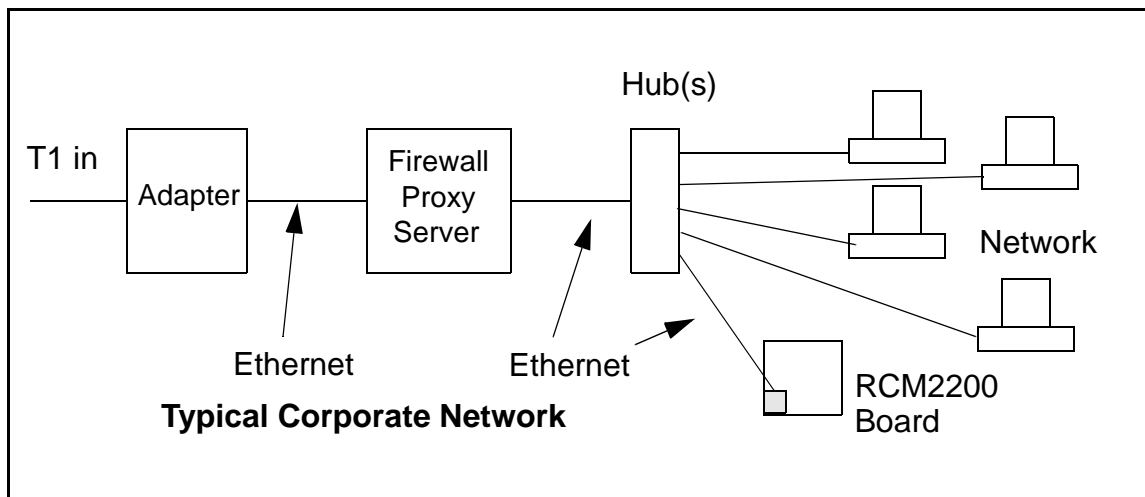

If your system administrator can give you an Ethernet cable along with its IP address, the netmask and the gateway address, then you may be able to run the sample programs without having to setup a direct connection between your computer and the RCM2200 board. You will also need the IP address of the nameserver, the name or IP address of your mail server, and your domain name for some of the sample programs.

4.3 IP Addresses Explained

IP (Internet Protocol) addresses are expressed as 4 decimal numbers separated by periods, for example:

216.103.126.155

10.1.1.6

Each decimal number must be between 0 and 255. The total IP address is a 32-bit number consisting of the 4 bytes expressed as shown above. A local network uses a group of adjacent IP addresses. There are always 2^N IP addresses in a local network. The netmask (also called subnet mask) determines how many IP addresses belong to the local network. The netmask is also a 32-bit address expressed in the same form as the IP address. An example netmask is:

255.255.255.0

This netmask has 8 zero bits in the least significant portion, and this means that 2^8 addresses are a part of the local network. Applied to the IP address above (216.103.126.155), this netmask would indicate that the following IP addresses belong to the local network:

216.103.126.0

216.103.126.1

216.103.126.2

etc.

216.103.126.254

216.103.126.255

The lowest and highest address are reserved for special purposes. The lowest address (216.103.126.0) is used to identify the local network. The highest address (216.103.126.255) is used as a broadcast address. Usually one other address is used for the address of the gateway out of the network. This leaves $256 - 3 = 253$ available IP addresses for the example given.

4.4 How IP Addresses are Used

The actual hardware connection via an Ethernet uses Ethernet adapter addresses (also called MAC addresses.) These are 48-bit addresses and are unique for every Ethernet adapter manufactured. In order to send a packet to another computer, given the IP address of the other computer, it is first determined if the packet needs to be sent directly to the other computer or to the gateway. In either case, there is an IP address on the local network to which the packet must be sent. A table is maintained to allow the protocol driver to determine the MAC address corresponding to a particular IP address. If the table is empty, the MAC address is determined by sending an Ethernet broadcast packet to all devices on the local network asking the device with the desired IP address to answer with its MAC address. In this way, the table entry can be filled in. If no device answers, then the device is nonexistent or inoperative, and the packet cannot be sent.

IP addresses are arbitrary and can be allocated as desired provided that they don't conflict with other IP addresses. However, if they are to be used with the Internet, then they must be numbers that are assigned to your connection by proper authorities, generally by delegation via your service provider.

4.5 Dynamically Assigned Internet Addresses

In many instances, there are no fixed IP addresses. This is the case when, for example, you are assigned an IP address dynamically by your dial-up Internet service provider (ISP) or when you have a device that provides your IP addresses using the Dynamic Host Configuration Protocol (DHCP). The RCM2200 can use such IP addresses to send and receive packets on the Internet, but you must take into account that this IP address may only be valid for the duration of the call or for a period of time, and could be a private IP address that is not directly accessible to others on the Internet. These private address can be used to perform some Internet tasks such as sending e-mail or browsing the Web, but usually cannot be used to participate in conversations that originate elsewhere on the Internet. If you want to find out this dynamically assigned IP address, under Windows XP you can run the `ipconfig` program while you are connected and look at the interface used to connect to the Internet.

Many networks use private IP addresses that are assigned using DHCP. When your computer comes up, and periodically after that, it requests its networking information from a DHCP server. The DHCP server may try to give you the same address each time, but a fixed IP address is usually not guaranteed.

If you are not concerned about accessing the RCM2200 from the Internet, you can place the RCM2200 on the internal network using a private address assigned either statically or through DHCP.

4.6 Placing Your Device on the Internet

In many corporate settings, users are isolated from the Internet by a firewall and/or a proxy server. These devices attempt to secure the company from unauthorized network traffic, and usually work by disallowing traffic that did not originate from inside the network. If you want users on the Internet to communicate with your RCM2200, you have several options. You can either place the RCM2200 directly on the Internet with a real Internet address or place it behind the firewall. If you place the RCM2200 behind the firewall, you need to configure the firewall to translate and forward packets from the Internet to the RCM2200.

4.7 How to Set IP Addresses in the Sample Programs

We have provided a number of sample programs demonstrating various uses of TCP/IP for networking embedded systems. These programs require that you connect your PC and the Coyote together on the same network. This network can be a local private network (preferred for initial experimentation and debugging), or a connection via the Internet.

With the introduction of Dynamic C 7.30 we have taken steps to make it easier to run many of our sample programs. You will see a `TCPCONFIG` macro. This macro tells Dynamic C to select your configuration from a list of default configurations. You will have three choices when you encounter a sample program with the `TCPCONFIG` macro.

1. You can replace the `TCPCONFIG` macro with individual `MY_IP_ADDRESS`, `MY_NETMASK`, `MY_GATEWAY`, and `MY_NAMESERVER` macros in each program.
2. You can leave `TCPCONFIG` at the usual default of 1, which will set the IP configurations to `10.10.6.100`, the netmask to `255.255.255.0`, and the nameserver and gateway to `10.10.6.1`. If you would like to change the default values, for example, to use an IP address of `10.1.1.2` for the Coyote board, and `10.1.1.1` for your PC, you can edit the values in the section that directly follows the “General Configuration” comment in the `TCP_CONFIG.LIB` library. You will find this library in the `LIB\TCPIP` directory.
3. You can create a `CUSTOM_CONFIG.LIB` library and use a `TCPCONFIG` value greater than 100. Instructions for doing this are at the beginning of the `TCP_CONFIG.LIB` library in the `LIB\TCPIP` directory.

There are some other “standard” configurations for `TCPCONFIG` that let you select different features such as DHCP. Their values are documented at the top of the `TCP_CONFIG.LIB` library in the `LIB\TCPIP` directory. More information is available in the *Dynamic C TCP/IP User's Manual*.

IP Addresses Before Dynamic C 7.30

Most of the sample programs use macros to define the IP address assigned to the board and the IP address of the gateway, if there is a gateway. Instead of the `TCPCONFIG` macro, you will see a `MY_IP_ADDRESS` macro and other macros.

```
#define MY_IP_ADDRESS "10.10.6.170"  
#define MY_NETMASK "255.255.255.0"  
#define MY_GATEWAY "10.10.6.1"  
#define MY_NAMESERVER "10.10.6.1"
```

In order to do a direct connection, the following IP addresses can be used for the Coyote:

```
#define MY_IP_ADDRESS "10.1.1.2"  
#define MY_NETMASK "255.255.255.0"  
// #define MY_GATEWAY "10.10.6.1"  
// #define MY_NAMESERVER "10.10.6.1"
```

In this case, the gateway and nameserver are not used, and are commented out. The IP address of the board is defined to be `10.1.1.2`. The IP address of your PC can be defined as `10.1.1.1`.

4.8 How to Set Up Your Computer for Direct Connect

Follow these instructions to set up your PC or notebook. Check with your administrator if you are unable to change the settings as described here since you may need administrator privileges. The instructions are specifically for Windows 2000, but the interface is similar for other versions of Windows.

TIP: If you are using a PC that is already on a network, you will disconnect the PC from that network to run these sample programs. Write down the existing settings before changing them to facilitate restoring them when you are finished with the sample programs and reconnect your PC to the network.

1. Go to the control panel (**Start > Settings > Control Panel**), and then double-click the Network icon.
2. Select the network interface card used for the Ethernet interface you intend to use (e.g., **TCP/IP Xircom Credit Card Network Adapter**) and click on the “Properties” button. Depending on which version of Windows your PC is running, you may have to select the “Local Area Connection” first, and then click on the “Properties” button to bring up the Ethernet interface dialog. Then “Configure” your interface card for a “10Base-T Half-Duplex” or an “Auto-Negotiation” connection on the “Advanced” tab.

NOTE: Your network interface card will likely have a different name.

3. Now select the **IP Address** tab, and check **Specify an IP Address**, or select TCP/IP and click on “Properties” to assign an IP address to your computer (this will disable “obtain an IP address automatically”):

IP Address : 10.10.6.101

Netmask : 255.255.255.0

Default gateway : 10.10.6.1

4. Click **<OK>** or **<Close>** to exit the various dialog boxes.

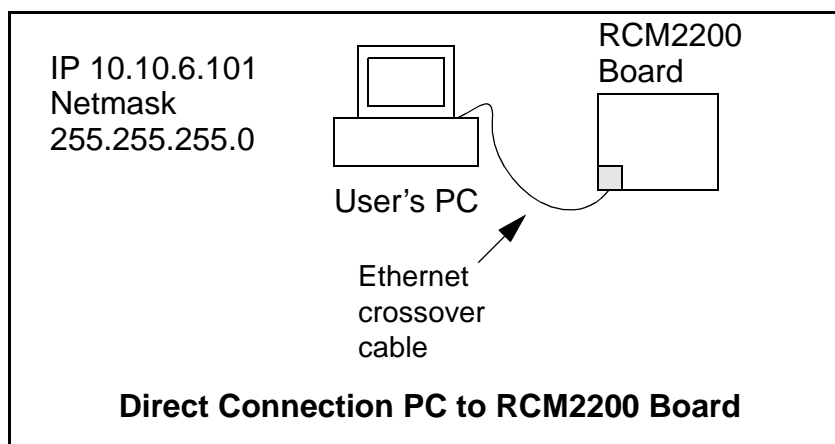

4.9 Run the PINGME.C Sample Programs

Connect the crossover cable from your computer's Ethernet port to the RCM2200 board's RJ-45 Ethernet connector. Open this sample program from the **SAMPLES\TCPIP\ICMP** folder, compile the program, and start it running under Dynamic C. When the program starts running, the green **LNK** light on the RCM2200 board should be on to indicate an Ethernet connection is made. (Note: If the **LNK** light does not light, you may not have a crossover cable, or if you are using a hub perhaps the power is off on the hub.)

The next step is to ping the board from your PC. This can be done by bringing up the MS-DOS window and running the pingme program:

```
ping 10.10.6.100
```

or by **Start > Run**

and typing the entry

```
ping 10.10.6.100
```

Notice that the red **ACT** light flashes on the RCM2200 board while the ping is taking place, and indicates the transfer of data. The ping routine will ping the board four times and write a summary message on the screen describing the operation.

4.10 Running More Sample Programs With Direct Connect

The sample programs discussed here are in the Dynamic C **SAMPLES\RCM2200** folder.

- **CONSOLE.C**—Demonstrates the features of **ZCONSOLE.LIB** command-oriented console library. This program is also run in conjunction with **SERDCLIENT.C** or **SPCLIENT.C**.
- **ETHCORE1.C**—Creates two “devices” (lights) and two “buttons” in the Web browser to toggle them. Users can change the status of the lights. If the RCM2200 is plugged into the **MASTER** slot on the Prototyping Board, the lights on the Prototyping Board will track the ones in the Web browser. As long as you have not modified the **TCPCONFIG 1** macro in the sample program, enter the following server address in your Web browser to bring up the Web page served by the sample program.

```
http://10.10.6.100
```

Otherwise use the TCP/IP settings you entered in the **TCP_CONFIG.LIB** library.

- **MYECHO.C**—Operates RCM2200 as a basic server. When a client connects, echoes back any data sent by the client.
- **SERDCLIENT.C**—Demonstrates the ability of a Rabbit-based target board to update files on the Web server of the RCM2200 board it is connected to via Serial Port D. This program is run in conjunction with **CONSOLE.C**.
- **SPCLIENT.C**—Demonstrates the ability of a Rabbit-based target board to update files on the Web server of the RCM2200 board it is connected to via the slave port. This program is run in conjunction with **CONSOLE.C**.

4.11 Where Do I Go From Here?

NOTE: If you purchased your RCM2200 through a distributor or through a Z-World or Rabbit Semiconductor partner, contact the distributor or Z-World partner first for technical support.

If there are any problems at this point:

- Use the Dynamic C **Help** menu to get further assistance with Dynamic C.
- Check the Z-World/Rabbit Semiconductor Technical Bulletin Board at www.zworld.com/support/bb/.
- Use the Technical Support e-mail form at www.zworld.com/support/questionSubmit.shtml.

If the sample programs ran fine, you are now ready to go on.

Additional sample programs are described in the *Dynamic C TCP/IP User's Manual*.

Please refer to the *Dynamic C TCP/IP User's Manual* to develop your own applications. *An Introduction to TCP/IP* provides background information on TCP/IP, and is available on the CD and on [Z-World's Web site](#).



NOTICE TO USERS

Z-WORLD PRODUCTS ARE NOT AUTHORIZED FOR USE AS CRITICAL COMPONENTS IN LIFE-SUPPORT DEVICES OR SYSTEMS UNLESS A SPECIFIC WRITTEN AGREEMENT REGARDING SUCH INTENDED USE IS ENTERED INTO BETWEEN THE CUSTOMER AND Z-WORLD PRIOR TO USE. Life-support devices or systems are devices or systems intended for surgical implantation into the body or to sustain life, and whose failure to perform, when properly used in accordance with instructions for use provided in the labeling and user's manual, can be reasonably expected to result in significant injury.

No complex software or hardware system is perfect. Bugs are always present in a system of any size. In order to prevent danger to life or property, it is the responsibility of the system designer to incorporate redundant protective mechanisms appropriate to the risk involved.

All Z-World products are 100 percent functionally tested. Additional testing may include visual quality control inspections or mechanical defects analyzer inspections. Specifications are based on characterization of tested sample units rather than testing over temperature and voltage of each unit. Z-World products may qualify components to operate within a range of parameters that is different from the manufacturer's recommended range. This strategy is believed to be more economical and effective. Additional testing or burn-in of an individual unit is available by special arrangement.

INDEX

A

additional information
 online documentation 4
 references 3

C

C language 15

D

Development Kit 5
Dynamic C 3, 15
 add-on modules 26
 installing 17
 sample programs 18
 standard features 16
 debugging 16
 telephone-based technical
 support 26
 upgrades and patches 26
 USB port settings 12

E

Ethernet cables 27
Ethernet connections 27, 30
 10Base-T 30
 10Base-T Ethernet card 27
 additional resources 38
 Ethernet cables 30
 Ethernet hub 27
 IP addresses 29, 31
 steps 27, 28

F

features
 Prototyping Board 6, 7
 RCM2200 1

H

hardware connections
 install RCM2200 on Prototyp-
 ing Board 9
 power supply 11
 programming cable 10
 hardware reset 11

I

IP addresses 31
 how to set 35
 how to set PC IP address ... 36

J

JP1
 Prototyping Board 8

P

pinout
 RCM2200 2
power supply
 connections 11
programming cable
 RCM2200 connections 10
Prototyping Board 6
 expansion area 8
 features 6, 7
 mounting RCM2200 9
 optional header JP1 8
 power supply connections . 11

R

RCM2200
 mounting on Prototyping
 Board 9
 reset 11
 running TCP/IP sample pro-
 grams 29

S

sample programs 18
 getting to know the RCM2200
 EXTSRAM.C 19
 FLASHLED.C 19, 23
 FLASHLEDS.C 19, 24
 KEYLCD.C 20
 TOGGLELED.C 19, 25
 how to set IP address 35
 PONG.C 12
 serial communication
 MASTER.C 22
 PUTS.C 21
 SLAVE.C 22
 TCP/IP 29
 CONSOLE.C 37
 ETHCORE1.C 37
 MYECHO.C 37
 PINGME.C 37
 running TCP/IP sample
 programs 29
 SERDCLIENT.C 37
 SPCLIENT.C 37

software
 sample programs 18
specifications
 physical and electrical 2

T

technical support 13

U

USB/serial port converter 10
 Dynamic C settings 12



SCHEMATICS

090-0120 RCM2200 Schematic

www.rabbitsemiconductor.com/documentation/schemat/090-0120.pdf

090-0122 RCM2200 Prototyping Board Schematic

www.rabbitsemiconductor.com/documentation/schemat/090-0122.pdf

090-0128 Programming Cable Schematic

www.rabbitsemiconductor.com/documentation/schemat/090-0128.pdf

The schematics included with the printed manual were the latest revisions available at the time the manual was last revised. The online versions of the manual contain links to the latest revised schematic on the Web site. You may also use the URL information provided above to access the latest schematics directly.

