

3G/HD/SD-SDI/ASI Fibre Optic Link



User Manual

Revision History:

Revision	Date	By	Change Description	Applicable to:
00	19/06/2013	AL	Original Issue.	Units fitted with firmware version ≥ Dxx463xS1V3

Table of Contents:

Section	Page
Revision History	2
Operational Safety	4
General Description	5
Technical Specifications	6
Configuration	7
User DIP switch settings	7
DDT-4630	7
DDR-4630	7
Installation	8
Signal Connections	8
DDT-4630	8
DDR-4630	9
Optical Connections	9
Alarm Connections	9
DDT-4630	9
DDR-4630	9
Front and rear layouts	10
Operation	11
Figure 1: Attenuation versus wavelength	12
Front Panel LED Indicators	12
SD only, HD/SD only modes	12
SNMP – What Is It?	13
DDT-4630 & DDR-4630 SNMP Functions	15
DDT-4630	15
DDR-4630	17
Maintenance & Storage	19
Warranty & Service	19

This instruction book applies to units fitted with firmware version \geq Dxx463xS1V3.

WARNING

Operation of electronic equipment involves the use of voltages and currents that may be dangerous to human life. Note that under certain conditions dangerous potentials may exist in some circuits when power controls are in the **OFF** position. Maintenance personnel should observe all safety regulations.

Do not make any adjustments inside equipment with power **ON** unless proper precautions are observed. All internal adjustments should only be made by suitably qualified personnel. All operational adjustments are available externally without the need for removing covers or use of extender cards.

Optical Safety

The light emitted from the LASER diode used in this system is invisible and may be harmful to the human eye. Avoid looking directly into the fibre optic cable or connectors or into the collimated beam along their axis when the device is in operation. Operating the LASER diode outside of its maximum ratings may cause device failure or a safety hazard.

DANGER

Invisible LASER radiation-
Avoid direct exposure to beam

Peak power	2 mW
Wavelength	1270–1610nm

Class 1 LASER Product

BLOCK DIAGRAM DDT-4630 & DDR-4630 SIGNAL PATH

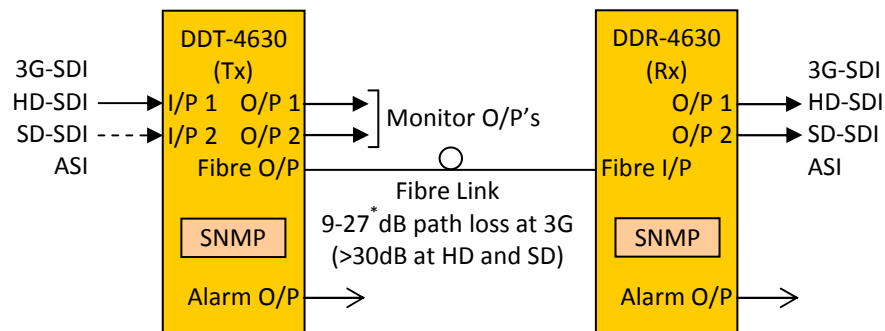

NOTE: * Fitted with APD detector. 3-18 dB when fitted with PIN detector.

The IRT DDT-4630 and DDR-4630 are transmit and receive modules designed principally for use as a serial data fibre optic transmission link for 3G-SDI, HD-SDI or SD-SDI applications conforming to SMPTE standards 424M, 292M and 259M-C using 9/125 μm single mode fibre. This enables the use of space saving fibre optic cable for reliable transmission of digital video signals over lengths greater than can be achieved with coaxial cable.

In addition, the link may be used for ASI transport streams for use with MPEG compressed video streams or other 270 Mb/s type data.

The transmitter features automatic input cable equalisation. The unit can be configured with lasers of various wavelengths.

LED indicators are provided for digital signal presence, DC power and LASER failure.

A link selectable “keep link alive” signal is available to maintain optical link operation when no electrical input is present.

Two inputs are provided with automatic changeover to input 2 on loss of input 1 for input signal redundancy.

The receiver uses a choice of either a PIN photodiode or APD detector with signal conditioning and reclocking circuits. The data rate is automatically set to match the 3G-SDI, HD-SDI or SD-SDI rates dependent on the actual input data rate to the transmitter.

Two serial digital outputs are provided. LED indicators are provided for digital signal presence, signal type, optical loss and power.

Relay contact outputs are also provided for external use of alarm signals on both modules.

SNMP (Simple Network Management Protocol) is available for remote monitoring when used in conjunction with an IRT frame fitted with SNMP capability.

Standard features:

- Transports 3G-SDI, HD-SDI, SD-SDI or ASI signal rates.
- Path lengths up to 30 dB¹ optical path loss using 9/125 μm single mode fibre.
- Automatic changeover switching of input for signal redundancy on Tx.
- LED indicators and external alarm contacts.
- Fibre, video and alarm connections at rear.
- Remote monitoring via SNMP.

NOTE: 1 27dB path loss at 3G. Typically >30dB at HD and SD. Fitted with APD detector.

TECHNICAL SPECIFICATIONS

DDT-4630:

Input serial data signal	2.97 Gb/s (3G-SDI) to SMPTE 424M; 1.485 Gb/s (HD-SDI) to SMPTE 292M; 270 Mb/s (SD-SDI) to SMPTE 259M-C and DVB-ASI.
Input impedance	75 Ω.
Input return loss	> 15 dB 5 MHz to 1.5 GHz; > 10 dB 1.5 GHz to 2.97 GHz.
Automatic cable compensation	> 100 m at 2.97 Gb/s (3G-SDI) with Belden 1694A (typ. 110m); > 100 m at 1.485 Gb/s (HD-SDI) with Belden 1694A (typ. 160m); > 250 m at 270 Mb/s (SD-SDI/ASI) with Belden 8281 (typ. >300m).
Input connector	2 x BNC on rear panel, with I/P 1 taking priority & I/P 2 automatically switching in on loss of I/P 1.
Output connector	2 x BNC on rear panel, monitor outputs.

DDR-4630:

Number of outputs	2 data reclocked, AC coupled.
Output level	800 mV ± 10%.
Output impedance	75 Ω.
Output return loss	> 15 dB 5 MHz to 1.5 GHz; > 10 dB 1.5 GHz to 2.97 GHz.
Output rise and fall time	< 135 ps at 2.97 Gb/s and 1.485 Gb/s; > 0.4 ns and < 1.5 ns at 270 Mb/s.
Intrinsic jitter	< 0.3 UI at 2.97 Gb/s reclocked; < 0.2 UI at 1.485 Gb/s reclocked; < 0.1 UI at 270 Mb/s reclocked.
Output connector	2 x BNC on rear assembly.

Optical:

DDT-4630 optical output	0 dBm +4.5/-0 dB CWDM DFB laser.
DDR-4630 optical input	APD detector, -9 to -27 dBm input level at 3G-SDI, typically < -30 dBm at HD/SD-SDI. PIN detector, -3 to -18 dBm input level at 3G-SDI, typically < -20 dBm at HD/SD-SDI.
Available wavelengths	CWDM DFB laser - 1270nm, 1290nm, 1310nm (standard), 1330nm, 1350nm, 1410nm, 1430nm, 1450nm, 1470nm, 1490nm, 1510nm, 1530nm, 1550nm, 1570nm, 1590nm & 1610nm.
Optical path loss²	9 to 27 dB at 3G-SDI, typically >30 dB at HD/SD-SDI, APD detector; 3 to 18 dB at 3G-SDI, typically >20 dB at HD/SD-SDI, PIN detector. (Optical path loss = Laser O/P power – Detector I/P power)
Optical fibre	Designed for use with 9/125 µm single mode fibre.
Optical connector	1 x SC/PC (standard) on rear – direct connection to main card.

Power Requirements:

Voltage	28 Vac CT (14-0-14) or ±16 Vdc.
Power consumption	DDT-4630 <5.0 VA, DDR-4630 <5.0 VA.

Other:

Temperature range	0 - 50° C ambient.
Mechanical	For mounting in IRT 19" rack chassis with input, output and power connections on the rear panel.
Finish	Grey, black lettering & red IRT logo.
Front panel	
Rear assembly	Detachable silk-screened PCB with direct mount connectors to Eurocard and external signals.
Dimensions	6 HP x 3 U x 220 mm IRT Eurocard.

NOTE: 2 Typical values based using DFB laser. Optical attenuator required for DDR-4630 when detector input is greater than -3dBm for PIN detector and -9dBm for APD detector.

CONFIGURATION

User DIP switch settings:



DDT-4630:

Tx Input Rate	DIP Switch	
	SW1-1	SW1-2
3G/HD/SD (Auto detect)	OFF	OFF
SD only	ON	OFF
HD and SD only	OFF	ON
Bypass Reclocker	ON	ON

- SW1-3 OFF** BNC outputs (OUT 1 and OUT 2) monitor the signal (IN1 or IN2) being fed to the optical output.
- ON** BNC outputs (OUT 1 and OUT 2) monitor the signal inputs (IN1 and IN2).
OUT 1 = IN 1 and OUT 2 = IN 2.
- SW1-4** Not used.
- SW1-5 OFF** Enable Laser - laser is always enabled: 'keep link alive' signal when no input signal is present.
- ON** Auto Laser – laser is enabled only when an input signal is present.
- SW1-6 OFF** Enable automatic input changeover on loss of primary input (IN 1) to Tx. (IN 1 takes priority over IN 2).
- ON** Disable automatic input changeover.
- SW1-7 OFF** DIP switch control.
- ON** SNMP control.
- SW1-8 OFF** Enable major and minor SNMP alarms to the frame Agent (CDM card)³.
- ON** Disable major and minor SNMP alarms to the frame Agent (CDM card)³.

DDR-4630:

Rx Output Rate	DIP Switch	
	SW1-1	SW1-2
3G/HD/SD (Auto detect)	OFF	OFF
SD only	ON	OFF
HD and SD only	OFF	ON
Bypass Reclocker	ON	ON

- SW1-3** Not used.
- SW1-4** Not used.
- SW1-5** Not used.
- SW1-6** Not used.
- SW1-7 OFF** DIP switch control.
- ON** SNMP control.
- SW1-8 OFF** Enable major and minor SNMP alarms to the frame Agent (CDM card)³.
- ON** Disable major and minor SNMP alarms to the frame Agent (CDM card)³.

NOTE: 3 When using TRAPS via SNMP, depending on how system is set up, in order to avoid double reporting of alarms via the DDT-4630 or DDR-4630 card and the CDM card (SNMP Agent) of the frame, major and minor SNMP alarms that are reported to the CDM card of the frame can be disabled.

INSTALLATION

Pre-installation:

Handling:

This equipment may contain or be connected to static sensitive devices and proper static free handling precautions should be observed.

Where individual circuit cards are stored, they should be placed in antistatic bags. Proper antistatic procedures should be followed when inserting or removing cards from these bags.

Power:

AC mains supply: Ensure that operating voltage of unit and local supply voltage match and that correct rating fuse is installed for local supply.

DC supply: Ensure that the correct polarity is observed and that DC supply voltage is maintained within the operating range specified.

Earthing:

The earth path is dependent on the type of frame selected. In every case particular care should be taken to ensure that the frame is connected to earth for safety reasons. See frame manual for details.

Signal earth: For safety reasons a connection is made between signal earth and chassis earth. No attempt should be made to break this connection.

Installation in frame or chassis:

See details in separate manual for selected frame type.

Signal Connections:

DDT-4630:

The default setting of the DDT-4630 is to automatically operate at either **2.97 Gb/s 3G-SDI**, **1.485 Gb/s HD-SDI** or **270 Mb/s SD-SDI / ASI** signals and do not require any adjustment prior to use, with the exception of DIP switch options described in the *Configuration* section of this manual that also allow SD only, HD/SD only or reclocker bypass modes of operation.

The serial digital signal connections are made to the BNC connectors on the rear panel. IN 1 is the primary input to the DTR-4630. With DIP switch SW1-6 OFF, IN 2 becomes the secondary input and will switch in automatically on loss of a valid input to IN1. Upon restoration of a valid signal to the IN 1 port, the optical transmitter automatically restores back to the signal on the IN 1 port. With SW1-6 ON, automatic changeover is disabled and although IN 2 is still monitored it is essentially ignored as far as the laser output is concerned.

With DIP switch SW1-3 OFF, the OUT 1 and OUT 2 BNC connectors act as monitor ports for the transmitter output. It will monitor either the IN 1 or IN 2 input depending on which input is actually feeding the optical laser.

With DIP switch SW1-3 ON, the OUT 1 and OUT 2 BNC connectors act as respective monitor ports for both the IN 1 and IN 2 inputs. OUT 1 monitors the IN 1 port and OUT 2 monitors the IN 2 port.

DDT-4630 & DDR-4630

DDR-4630:

The default setting of the DDR-4630 is to automatically operate at either **2.97 Gb/s 3G-SDI**, **1.485 Gb/s HD-SDI** or **270 Mb/s SD-SDI / ASI** signals and do not require any adjustment prior to use, with the exception of DIP switch options described in the *Configuration* section of this manual that also allow SD only, HD/SD only or reclocker bypass modes of operation.

The serial digital signal connections are made to the BNC connectors on the rear panel. Two identical signal outputs, OUT 1 and OUT 2, are provided. BNC connectors IN 1 and IN 2 are not used.

Optical Connections:

Optical connections are made to the panel adapter mounted on a bracket at the rear of the module. Care must be taken to provide a clean surface on the optical connectors and in inserting the plug on the external fibre to prevent damage to the alignment ferrule of the panel adapter. Type of fibre used must be single mode type.

Note that for path lengths ≤ 9 dB for APD detectors, or ≤ 3 dB for PIN detectors, an optical attenuator must be used to avoid over driving the DDR-4630 detector.

Alarm Connections:

The external alarm contact connections are made to the 4 pin phoenix style connector on the rear assembly. On an alarm condition relay contacts go open circuit, that is switch open with respect to ground.

The connections being:



The alarms reported are designated as either Major or Minor.

DDT-4630:

A Major alarm is designated as a laser fail alarm.

A Minor alarm is designated as an input is missing, invalid or not enabled⁴. Note that if automatic changeover mode is disabled, the alarm condition for IN 2 is ignored regardless of its state.

DDR-4630:

A Major alarm is designated as an optical input fail to the detector.

A Minor alarm is designated as the signal output is missing, invalid or not enabled⁴; OR the optic input level has been deemed to be approaching , or has gone below, its threshold limit⁵.

- NOTE:**
- 4 It is possible, via SNMP, to disable signal channel on both the DDT-4630 and DDR-4630.
 - 5 This is reported as an 'opticalLow' condition via SNMP. Note that if a received electrical signal is present in this situation, it may be possible that the signal may contain errors if the optical signal level has actually gone below its minimum reliable input level before the output is muted, whence an 'opticalFail' situation would be reported. Therefore accuracy of the received electrical signal should be confirmed if a Minor alarm, or opticalLow, condition is reported by the DDR-4630.

DDT-4630 & DDR-4630

Front & rear panel connector diagrams:

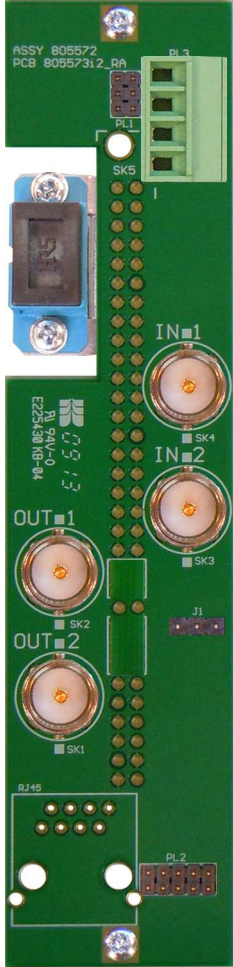
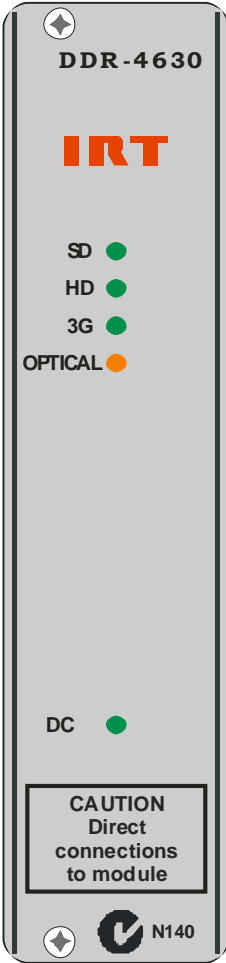
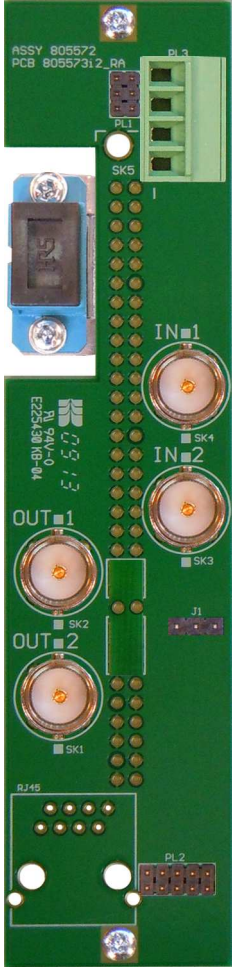
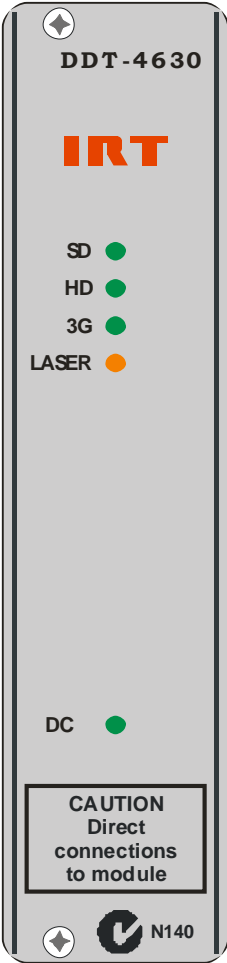

DDR-4630:
* IN 1 & IN 2 BNC connectors not used.

OPERATION

The DDT-4630 and DDR-4630 is a single channel 3G/HD/SD-SDI/ASI optical link. Both the DDT-4630 and DDR-4630 cards are fully operable with previous IRT single channel 3G, HD or SD fibre links.

The default settings of both the DDT-4630 and DDR-4630 are automatically set to operate at either **2.97 Gb/s 3G-SDI**, **1.485 Gb/s HD-SDI** or **270 Mb/s SD-SDI (or ASI)** and do not require any adjustments prior to use. However, either DIP switch or SNMP settings allow the unit to be set for SD only, SD/HD only or reclocker bypass modes.

A 2.97 Gb/s 3G-SDI signal, 1.485 Gb/s HD-SDI signal or a 270 Mb/s type of signal, such as ASI or SDI, is connected to a 75 Ω BNC connector (IN 1) of the rear assembly of the DDT-4630 fibre optic transmitter. Front panel LEDs indicates the presence and data rate of a valid input signal.

A second input (IN 2) can be automatically switched to the optical output (if enabled) on loss of a valid input signal to IN 1. On resumption of a valid signal to IN 1 the optical transmitter automatically switches back to the IN 1 input.

If the laser is set for permanent operation, on loss of an input signal, a 54MHz oscillator is switched into the optical output so that the optical receiver still recognizes the optical link as being valid. This 54MHz signal does not affect the signal reclocking detect circuitry of the receiver section, which is used in signal presence/alarm indication on detection or absence of a valid 3G, HD or SD signal.

Single mode optical cable is directly connected to the module at the rear of the unit. Likewise the fibre connection at the far end of the fibre optic cable is directly connected to the rear of the receiver.

The system will operate with an optical path loss from 9dB to a maximum of 27dB (for 3G-SDI signals. Typically >30dB for HD/SD-SDI signals) when fitted with an APD detector, and from 3dB to a maximum of 18dB when fitted with a PIN detector. An orange LED indicator on the front panel (LASER in the case of the DDT-4630 and OPTICAL in the case of the DDR-4630), and a relay alarm accessible by the rear assembly, indicates when a laser failure has occurred in the case of the DDT-4630, or the optical path loss is approaching, or has exceeded, the maximum allowed in the case of the DDR-4630. For path lengths <9dB optical loss when using an APD detector, or <3dB optical loss when using a PIN detector, an optical attenuator is required. The length of fibre that this corresponds to depends on the fibre loss characteristics at the relevant wavelength of the laser module chosen. For example, if the fibre loss characteristic of the chosen fibre is 0.2dB per kilometre at 1550 nm, say, then the maximum distance that can be run is 135 km (27dB/0.2dBkm), although connector losses, such as through patch lead connectors etc., should also be taken into consideration when calculating maximum distances. Actual attenuation versus wavelength characteristics depends upon optic fibre manufacturer's own specifications. Also a few dB headroom is recommended to allow for the effects of laser aging over time.

The output of the DDR-4630 receiver is the same signal that was originally inputted to the opposite DDT-4630 transmitter. Front panel green LEDs indicate the presence of a valid locked 3G-SDI, HD-SDI, or an SD-SDI type of output signal.

In the reclocker bypass mode rates other than the 3G/HD/SD-SDI rates can be sent and received. If the data rate does not match that of 3G-SDI, HD-SDI or SD-SDI all front panel signal data rate LED's will flash to indicate that an unknown data rate has been detected. Likewise an 'unknownPresent' data rate is reported via SNMP.

Through the use of SNMP (see separate section of manual) it is possible to remotely monitor and control various functions not available via the local DIP switch control. Such as, for example, it is possible to disable the channel on either or both the DDT-4630 and DDR-4630 locking out an end user's functionality should this be desired. When a signal (Tx or Rx) has been disabled, should an electrical signal be present, the corresponding data rate LED will flash - not to be confused with situation as described in *Front Panel LED Indicators* section below.

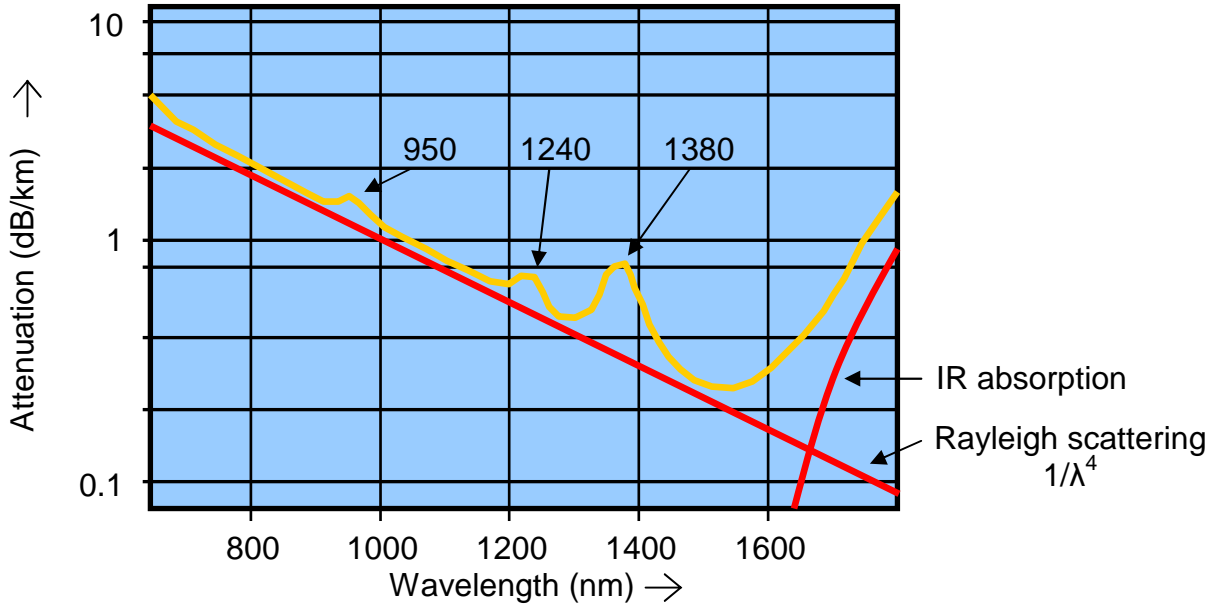
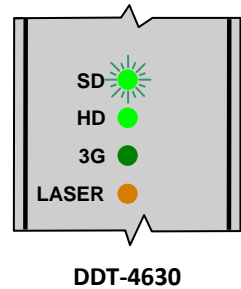

Figure 1: Attenuation versus wavelength.
Attenuation in the fibre is due to Absorption and Scattering.

Front Panel LED Indicators:

If the Tx or Rx input signal rate does not match the set rate, or the secondary input rate is not the same as the primary input rate, even though its rate is compatible with the set rate, the corresponding LED will flash.

In this example the DDT-4630 transmitter has been set for either HD/SD only or 3G/HD/SD operation. The primary input (IN 1) is being fed with an HD source. The secondary input (IN 2), even though its rate is within the Tx set rate, will flash as its rate is different to the primary input's rate. On loss of primary input the secondary will still take control and stop flashing as its rate is still within the set Tx rate.



If both primary and secondary inputs were HD-SDI and 3G-SDI signals, for example, and the Tx data rate was set for SD only operation, then both the HD and 3G LEDs will alternatively flash.

Laser failure on the DDT-4630 is indicated by an orange illuminated LASER LED. In the above example there is no laser failure as indicated by the non-illuminated LASER LED.

Optical Low, or optical input failure, on the DDR-4630 is indicated by an orange illuminated OPTICAL LED. In this example the OPTICAL LED is illuminated, but so is the HD signal LED. This indicates that an HD signal is being received even though the OPTICAL alarm LED is illuminated, thus the OPTICAL alarm LED is indicating that the optical signal level is low, or approaching the minimum signal strength allowed before signal failure takes place, whence the receiver output will be muted. Note however that it is still possible for the optical signal strength to be low and still allow an errored data signal to be received before signal muting takes place. This is because the optical alarm threshold is set for the 3G rate, which has a lower optical path loss than the HD and SD rates. If operating at signal paths close to the recommended maximum specified threshold, signal analysis should be performed to check the accuracy of the received signal if the OPTICAL LED is illuminated.

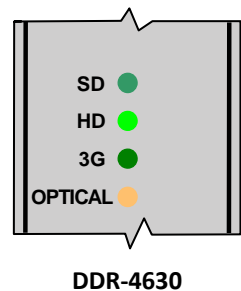

SD only, HD/SD only modes:

Note that it is possible to set the units to operate as an SD rate only or HD/SD rate only mode by use of the DIP switch configuration controls. However in situations where it is desired that the end user does not have control over the intended setup, it is possible to set the unit to the desired rate via SNMP control and to lock it to SNMP only control so that the end user cannot override the setup parameters by use of the DIP switches. This is intended for situations where a link has been leased to a customer who is only paying for a certain data rate path such as SD only or HD/SD only as opposed to the full 3G rate.

SNMP

What Is It?

SNMP stands for Simple Network Management Protocol. It is an application layer protocol for managing IP (Internet Protocol) based systems. SNMP enables system administrators to manage system performance, and to find and solve system problems. SNMP runs over UDP (User Datagram Protocol), which in turn runs over IP.

Three types of SNMP exist: SNMP version 1 (SNMPv1), SNMP version 2 (SNMPv2) and SNMP version 3 (SNMPv3). It is not the intention here to discuss the differences between various versions, only to bring attention to the fact that IRT Electronics modules, fitted with SNMP capability, use SNMPv1.

An SNMP managed network consists of three key components: Network Management Systems (*NMS*), *agents*, and *managed devices*.

An *NMS* is the console through which the network administrator performs network management functions, such as monitoring status (e.g. alarm states) and remote controlling, of a set of managed devices. One or more *NMS*'s must exist on any managed network. Generally the *NMS* is a computer running third party SNMP control software. There are a number of third party SNMP software applications currently available on the market.

An *NMS* polls, or communicates with, an *agent*. An *agent* is a network management software module that resides in a *managed device*. An *agent* has local knowledge of management information and translates that information into a form compatible with SNMP. The *agent*, therefore, acts as an interface between the *NMS* and the managed devices. The *NMS* sends a request message, and control commands for the managed devices, to the *agent*, which in turn sends a response message, containing information about the *managed devices*, back to the *NMS*.

A *managed device* contains an SNMP *agent* and resides on a managed network. *Managed devices* collect and store management information and make this information available to *NMS*'s using SNMP.

Managed device agent variables are organised in a tree structure known as a Management Information Base (*MIB*). Within the *MIB* are parameters pertaining to the *managed device*. An Object Identifier (OID) number within the *MIB* defines the managed device type. This is a unique number specific to the model of *managed device*. Other information relating to the device is also stored, information such as alarm states, controllable settings, etc. The *MIB* tree is organised in such a way that there will be no two *MIB* files with conflicting placements.

Normally an *NMS* polls an *agent* for information relating to the *MIB* in a managed device to be sent back to the *NMS*. When certain conditions are met within the *MIB*, such as major alarm conditions, for example, the *agent* automatically sends what is known as a *trap* to the *NMS* without any prompting from the *NMS*. This allows automatic notification of a predetermined event.

SNMP Block Diagram

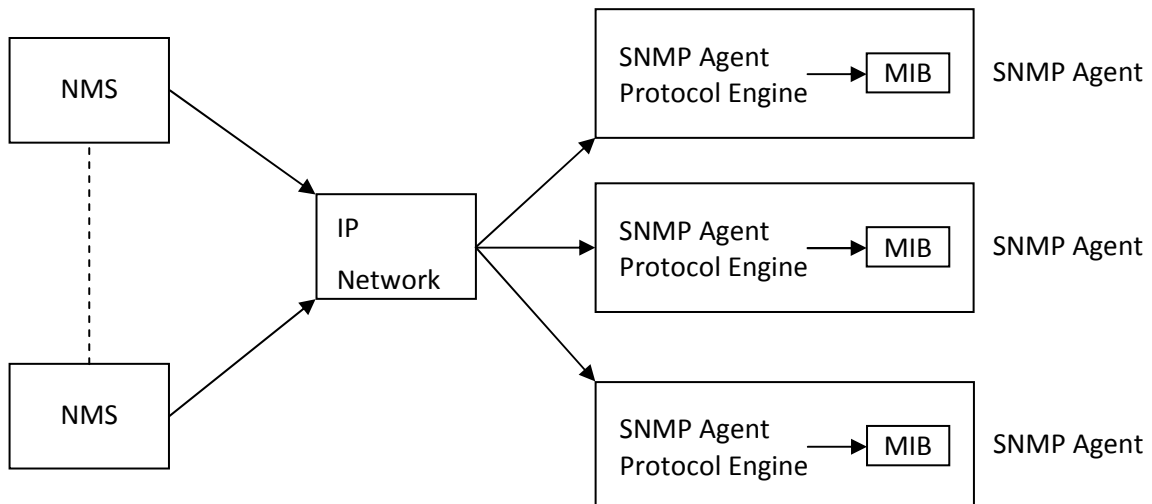

DDT-4630 & DDR-4630

SNMP with IRT Products:

IRT Electronics currently employs SNMPv1 with its SNMP capable frames. The frame acts as an *agent* when fitted with a CDM-xxxx module. This module has its own designated slot next to the power supply so as to not affect the number of modules that the frame will take. Communication between the *NMS*, the frame and its loaded modules are via this CDM-xxxx module. Note that the *NMS* software is third party and not supplied by IRT Electronics.

Ethernet connection for SNMP operation is via an RJ45 connector on the rear of the frame, below the mains inlet. Ethernet rate runs at either 10 baseT or 100 baseT.

Frame parameters, such as Name, Address and Location, are set via an RS232 interface, a D9 connector on the rear of the frame below the mains inlet. A software terminal emulator, such as Tera Term or HyperTerminal, is used for setting and reading the parameters of the frame.

IRT modules that are SNMP compatible may need an optional plug-in SNMP module with a program relevant to the module that it is plugged into. Depending on the module, besides the module identification, parameters such as alarm states, inputs and controls etc. are communicated to the CDM-xxxx *agent* via a data bus on the rear of the frame. Thus the CDM-xxxx collects information on what is loaded within the frame, what positions they occupy, and their current status for communication to the *NMS* when the *NMS* sends a request for information.

In the event of a major alarm from any of the SNMP compatible modules, or power supplies, a *trap* is automatically sent by the CDM-xxxx *agent* to the *NMS* without any prompting by the *NMS*. This alerts the operator to any fault conditions that may exist that need immediate attention.

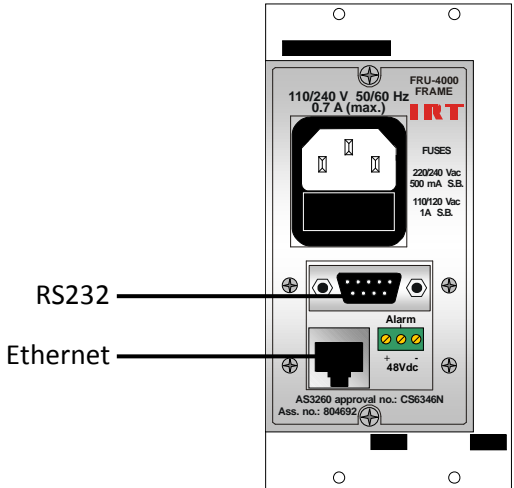

IRT SNMP Connections

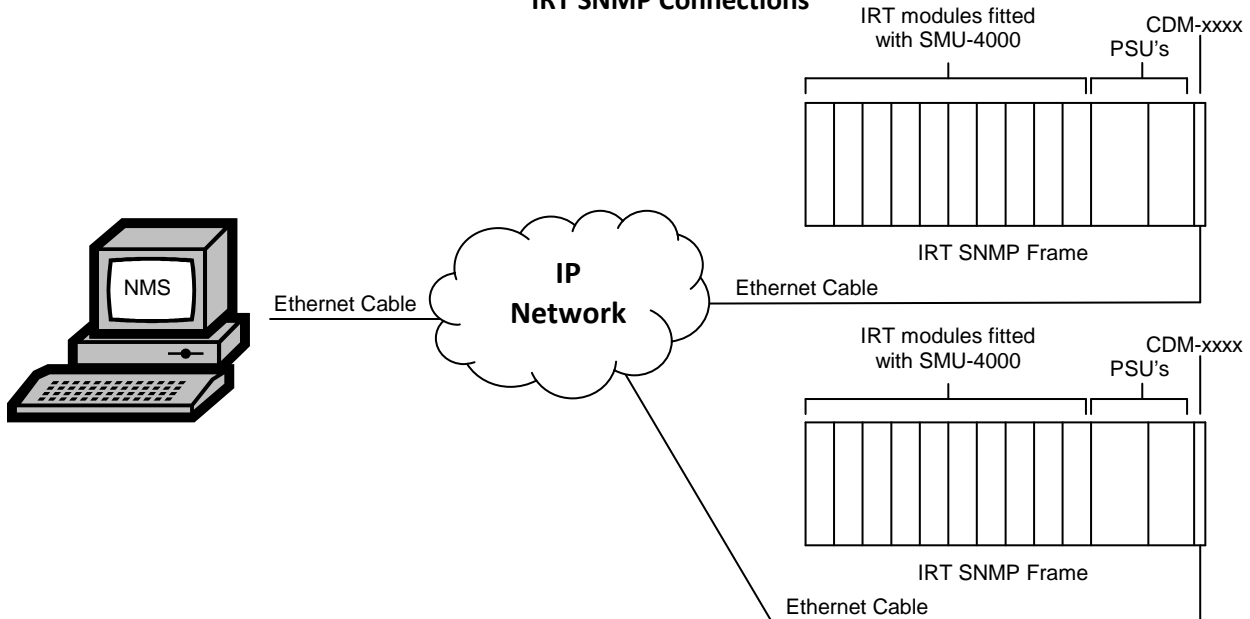

IRT SNMP Setup

DDT-4630 & DDR-4630

DDT-4630 & DDR-4630 SNMP Functions:

When installed in an IRT frame fitted with SNMP capability, the DDT-4630 and DDR-4630 can be interrogated by an SNMP Network Management System (NMS). The DDT-4630 and DDR-4630 belong to a series of fibre products that share a common framework and object identifier number (OID), when doing an SNMP 'walk' via the NMS the reported identifier in the slot position list is reported as being **irtDxx463x** where the 'x' signifies a wildcard character, in this case a 'D', 'T', 'R' and 'O' as in the DDT-4630 & DDR-4630 product numbers. The specific product type and details are revealed when expanding this identifier.

The following SNMP functions are capable of being monitored by an NMS, for SNMP control DIP switch SW1-7 must be set to ON:

DDT-4630:

sysDescr	- A description of the unit: Optical Transmitter
sysObjectID	- Object identifier: irtDDT4630
sysUpTime	- A indication of how long the unit has been running since its last power on or reset in Days, Hours, Minutes and Seconds.
sysName	- A 16 character writable system name. Default set name: DDT-4630
irt463xType	- An indication of the device type: (3) ddt4630-Transmitter
alarms	- An indication of the alarm type: (1) noAlarm: No alarms present. (2) urgent-1: Optical laser is faulty. (7) nonUrgent-1: Input signal IN 1 is absent or invalid. (8) nonUrgent-2: Input signal IN 2 is absent or invalid. Not applicable if automatic changeover mode is disabled. (9) nonUrgent-1-2: Both nonUrgent-1 and nonUrgent-2 alarms are present.
ctrlMode	- The current configuration setting's source as determined by DIP switch SW1-7 position: (1) pcbSwitches: Configuration set locally via on-board DIP switches (SW1-7 = OFF). (2) remoteSNMP: Configuration set remotely via SNMP (SW1-7 = ON). (3) lockToRemoteSNMP: Lock module to SNMP control – overrides SW1-7 position. Note that SW1-7 must be initially ON to be able to set to Lock to SNMP mode. To release send either a (1) or (2).
autoChangeOver	- Enable or Disable Automatic Changeover to switch Tx optical output from primary (In 1) to secondary (IN 2) input on loss of valid primary input (if secondary input is both present and valid): (1) disabled: Automatic Changeover mode disabled. (2) enabled: Automatic Changeover mode enabled. (3) na: Not applicable (as reported by DDR-4630). Setting this parameter has the same effect as disabled.
channelInfoTable	- Information and control of the DDT-4630 in table form.
channelInfoEntry	- Table data entry.
channelDesignator	- An indication of the channel designator: (3) ch-Tx: Primary signal input (IN 1) and Optical Transmitter settings column designator. (2) ch-2: Secondary signal input (IN 2) column designator.
inputStatus	- An indication of the signal rate present: (1) unknownPresent: Signal rate is not one of the 3G/HD/SD-SDI/ASI rates. (2) sdiSD-ASI-Present: Signal is either an SD-SDI or ASI signal, or at 270 Mb/s rate. (3) sdiHD-Present: Signal is either an HD-SDI signal, or at 1.485 Gb/s rate. (4) sdi3G- Present: Signal is either an 3G-SDI signal, or at 2.97 Gb/s rate. (5) notPresent: No signal is present.

DDT-4630 & DDR-4630

dataRateSet	- Control of the signal data rate setting: <ol style="list-style-type: none">(1) sdi3G-HD-SD-ASI: Reclocker set to 3G-SDI, HD-SDI or SD-SDI/ASI rates.(2) sdiHD-SD-ASI-only: Reclocker set to HD-SDI (1.485 Gb/s) and SD-SDI/ASI (270 Mb/s) rates only.(3) sdiSD-ASI-only: Reclocker set to SD-SDI/ASI (270 Mb/s) rate only.(4) bypassed: Reclocker bypassed to allow other signal rates through.(5) na: Not Applicable. If selected defaults to 3G/HD/SD-SDI/ASI rate setting.
channelEnable	- An indication and control of how and whether the channel is enabled: <ol style="list-style-type: none">(1) notEnabled: The electrical input signals are not enabled.(2) enabledActive: Electrical signal is both Enabled and Active. Relates to IN 1.(3) enabledMuted: Electrical signal is Enabled, but the output is Muted when no signal is present or the wrong data rate has been applied.(4) enabledChangedOver: Reported if <i>autoChangeOver</i> is enabled and signal on IN 1 is absent or invalid with a valid signal on IN 2 indicating that IN 2 is being transmitted.(5) na: Not Applicable. If selected defaults to current applicable <i>enabled</i> setting.
channelAlias	- A 16 character maximum Alias (name) for the input signals can be read and set.
blankLine	- A line spacing within the table to make reading the table easier.
channelKeepAlive	- A substitution of a 54 MHz signal in place of no input signal to keep the optical link active at the receiver end: <ol style="list-style-type: none">(1) on: Keep Alive signal active.(2) off: Keep Alive signal not active.(3) na: Not Applicable. If selected defaults to <i>Off</i> state.
chanPresTrapEnable	- Enable or Disable Traps to be sent when the electrical signal condition changes: <ol style="list-style-type: none">(1) notEnabled: No Traps sent on change of electrical signal presence.(2) enabled: Traps automatically sent on change of electrical signal presence.(3) na: Not Applicable. If selected defaults to <i>notEnabled</i> setting.
opticalStatus	- An indication of how the SFP optical component is functioning: <ol style="list-style-type: none">(1) opticalGood: DDT-4630 laser is present.(3) opticalFail: DDT-4630 laser has failed or is not present. No electrical signal present or signal is not at one of the settable 3G/HD/SD-SDI rates.
waveLength	- An indication DDT-4630 laser wavelength.
detectorType	- Applicable to the DDR-4630 only. See explanation for DDR-4630 SNMP function. <ol style="list-style-type: none">(3) na: Not Applicable.
opticalTrapEnable	- Enable or Disable Traps to be sent when the optical signal condition changes: <ol style="list-style-type: none">(1) notEnabled: No Traps sent on change of optical signal presence.(2) enabled: Traps automatically sent on change of optical signal presence.(3) na: Not Applicable. If selected defaults to <i>notEnabled</i> setting.
fpgaVersion	- An indication of the firmware version of the microcontroller in the format 'x.y', where x is the major revision number and y the minor.
reset	- Unit reset control: <ol style="list-style-type: none">(1) normal: when queried reset control returns a 'normal' state.(2) reset: system reset causes 'sysUpTime' counter to reset.

DDT-4630 & DDR-4630

DDR-4630:

- sysDescr** - A description of the unit:
Optical Receiver
- sysObjectID** - Object identifier:
irtDDR4630
- sysUpTime** - A indication of how long the unit has been running since its last power on or reset in
Days, Hours, Minutes and Seconds.
- sysName** - A 16 character writable system name. Default set name:
DDR-4630
- irt463xType** - An indication of the device type:
(4) ddr4630-Receiver
- alarms** - An indication of the alarm type:
(1) noAlarm: No alarms present.
(2) urgent-1: Optical input is absent.
(3) nonUrgent-1: Optical input is low or received electrical signal is absent or invalid.
- ctrlMode** - The current configuration setting's source as determined by DIP switch SW1-7 position:
(1) pcbSwitches: Configuration set locally via on-board DIP switches (SW1-7 = OFF).
(2) remoteSNMP: Configuration set remotely via SNMP (SW1-7 = ON).
(3) lockToRemoteSNMP: Lock module to SNMP control – overrides SW1-7 position.
Note that SW1-7 must be initially ON to be able to set to Lock to SNMP mode.
To release send either a (1) or (2).
- autoChangeOver** - Applicable to DDT-4630 only. See explanation for DDT-4630 SNMP function.
(3) na: Not applicable. Setting this parameter has the same effect as disabled.
- channelInfoTable** - Information and control of the DDT-4630 in table form.
 - channelInfoEntry** - Table data entry.
 - channelDesignator** - An indication of the channel designator:
(4) ch-Rx: Optical Receiver settings column designator.
 - inputStatus** - An indication of the signal rate present within the received optical signal:
(1) unknownPresent: Signal rate is not one of the 3G/HD/SD-SDI/ASI rates.
(2) sdiSD-ASI-Present: Signal is either an SD-SDI or ASI signal, or at 270 Mb/s rate.
(3) sdiHD-Present: Signal is either an HD-SDI signal, or at 1.485 Gb/s rate.
(4) sdi3G-Present: Signal is either an 3G-SDI signal, or at 2.97 Gb/s rate.
(5) notPresent: No signal is present.
 - dataRateSet** - Control of the signal data rate setting:
(1) sdi3G-HD-SD-ASI: Reclocker set to 3G-SDI, HD-SDI or SD-SDI/ASI rates.
(2) sdiHD-SD-ASI-only: Reclocker set to HD-SDI (1.485 Gb/s) and SD-SDI/ASI (270 Mb/s) rates only.
(3) sdiSD-ASI-only: Reclocker set to SD-SDI/ASI (270 Mb/s) rate only.
(4) bypassed: Reclocker bypassed to allow other signal rates through.
(5) na: Not Applicable. If selected defaults to 3G/HD/SD-SDI/ASI rate setting.
 - channelEnable** - An indication and control of how and whether the channel is enabled:
(1) notEnabled: The electrical output signal is not enabled.
(2) enabledActive: Electrical signal is both Enabled and Active.
(3) enabledMuted: Electrical signal is Enabled, but the output is Muted when no signal is present or the wrong data rate has been applied.
(4) enabledChangedOver: Not Applicable. If selected defaults to current applicable *enabled* setting.
(5) na: Not Applicable. If selected defaults to current applicable *enabled* setting.
- channelAlias** - A 16 character maximum Alias (name) for the input signals can be read and set.
- blankLine** - A line spacing within the table to make reading the table easier.
- channelKeepAlive** - Applicable to DDT-4630 only. See explanation for DDT-4630 SNMP function.
(3) na: Not Applicable.

DDT-4630 & DDR-4630

- chanPresTrapEnable** - Enable or Disable Traps to be sent when the electrical signal condition changes:
- (1) notEnabled: No Traps sent on change of electrical signal presence.
 - (2) enabled: Traps automatically sent on change of electrical signal presence.
 - (3) na: Not Applicable. If selected defaults to *notEnabled* setting.
- opticalStatus** - An indication of how the SFP optical component is functioning:
- (1) opticalGood: DDR-4630 optical input level is good.
 - (2) opticalLow: DDR-4630 optical input level has gone below its minimum input threshold AND electrical signal presence is also reported (may or may not contain signal errors).
 - (3) opticalFail: DDR-4630 optical input level has gone below its minimum input threshold AND no electrical signal is present.
- waveLength** - Applicable to DDT-4630 only. DDR-4630 always reports:
- (16) wideband: Indicates that it is a wideband receiver.
- detectorType** - An indication of the detector type (PIN or APD) fitted to the DDR-4630.
- (1) pin: PIN detector fitted. Suitable for path losses up to 18dB⁶ at 3G-SDI rate.
 - (2) apd: APD detector fitted. Suitable for path losses up to 27dB⁷ at 3G-SDI rate.
- opticalTrapEnable** - Enable or Disable Traps to be sent when the optical signal condition changes:
- (1) notEnabled: No Traps sent on change of optical signal presence.
 - (2) enabled: Traps automatically sent on change of optical signal presence.
 - (3) na: Not Applicable. If selected defaults to *notEnabled* setting.
- fpgaVersion** - An indication of the firmware version of the microcontroller in the format 'x.y', where x is the major revision number and y the minor.
- reset** - Unit reset control:
- (1) normal: when queried reset control returns a 'normal' state.
 - (2) reset: system reset causes 'sysUpTime' counter to reset.

- NOTE:** 6 Typically > 20dB at HD/SD-SDI rates. Optical attenuator required for optical input levels \geq -3dBm.
- 7 Typically > 30dB at HD/SD-SDI rates. Optical attenuator required for optical input levels \geq -9dBm.

MAINTENANCE & STORAGE

Maintenance:

No regular maintenance is required.

Care however should be taken to ensure that all connectors are kept clean and free from contamination of any kind. This is especially important in fibre optic equipment where cleanliness of optical connections is critical to performance.

Storage:

If the equipment is not to be used for an extended period, it is recommended the whole unit be placed in a sealed plastic bag to prevent dust contamination. In areas of high humidity a suitably sized bag of silica gel should be included to deter corrosion.

Where individual circuit cards are stored, they should be placed in antistatic bags. Proper antistatic procedures should be followed when inserting or removing cards from these bags.

WARRANTY & SERVICE

Equipment is covered by a limited warranty period of three years from date of first delivery unless contrary conditions apply under a particular contract of supply. For situations when “**No Fault Found**” for repairs, a minimum charge of 1 hour’s labour, at IRT’s current labour charge rate, will apply, whether the equipment is within the warranty period or not.

Equipment warranty is limited to faults attributable to defects in original design or manufacture. Warranty on components shall be extended by IRT only to the extent obtainable from the component supplier.

Equipment return:

Before arranging service, ensure that the fault is in the unit to be serviced and not in associated equipment. If possible, confirm this by substitution.

Before returning equipment contact should be made with IRT or your local agent to determine whether the equipment can be serviced in the field or should be returned for repair.

The equipment should be properly packed for return observing antistatic procedures.

The following information should accompany the unit to be returned:

1. A fault report should be included indicating the nature of the fault
2. The operating conditions under which the fault initially occurred.
3. Any additional information, which may be of assistance in fault location and remedy.
4. A contact name and telephone and fax numbers.
5. Details of payment method for items not covered by warranty.
6. Full return address.
7. For situations when “**No Fault Found**” for repairs, a minimum charge of 1 hour’s labour will apply, whether the equipment is within the warranty period or not. Contact IRT for current hourly rate.

Please note that all freight charges are the responsibility of the customer.

The equipment should be returned **to the agent who originally supplied the equipment** or, where this is not possible, to IRT directly. Details of IRT’s direct address can be found at IRT Electronics’ website.

Web address: www.irtelectronics.com

Email: sales@irtelectronics.com