

Technical Manual

MC 36 A

Code Nr. 99 97 5007

Ausgabe 06 01 M5007 GB

Nr.: 606181



Big Dutchman International GmbH · Calveslage · Auf der Lage 2 · 49377 Vechta

Rufnr. 04447/801-0 · Fax 04447/801-237

Thank you very much for your confidence!

We want to congratulate you on your Big Dutchman

MC 36 A computer

and we are convinced that you will be satisfied with it.



EC Declaration of Conformity

We declare that the design and model of the machine described above being placed on the market by ourselves complies with the relevant health and safety requirements of the EC Directive.

Guarantee Declaration

This machine is guaranteed in accordance with the **Big Dutchman** International GmbH General Conditions of Sale for customers resident in Germany and the **Big Dutchman** International GmbH International Conditions of Sale for customers not resident in Germany.

Note

In order to ensure that your new equipment will always work properly and efficiently and to ensure your personal safety, we would ask you the following:

Please read through this User Manual thoroughly and take particular note of the warning and safety instructions before starting up the machine for the first time.

Programme Version:

The product described in this manual is computer based, and most functions are realised by software. This manual corresponds to:

SOFTWARE VERSION 4.1

It was released in March 2001.

Produkt and documentation revision:

BIG DUTCHMAN reserve our rights to change this document and the product herein described without further notice. BIG DUTCHMAN cannot guarantee that you will receive information about changes of the product or the manual. In case of doubt, please contact BIG DUTCHMAN.

Latest date of change appears from the front-page. The date is only changed on the pages included in the revision.

NOTE

- All rights reserved. No part of this manual may be reproduced in any manner whatsoever without the expressed written permission of BIG DUTCHMAN in each case.
- The contents of this manual are subject to change without notice.
- BIG DUTCHMAN has made reasonable efforts to ensure the accuracy of the information contained herein.
Should any mistakes or unprecise information occur, BIG DUTCHMAN would appreciate being notified hereof.
- Irrespective of the above, BIG DUTCHMAN shall not have any liability with respect to loss or damage caused or alleged to be caused by reliance on any information contained herein

Copyright 2001 by BIG DUTCHMAN

IMPORTANT

NOTES CONCERNING THE ALARM SYSTEM

Where climatic control is used in livestock buildings, break-downs, malfunctions or faulty settings may cause substantial damage and financial losses. It is therefore most ***important to install a separate, independent alarm system***, which monitors the house concurrently with climatic control. Please note that the product liability clause of BIG DUTCHMAN A/S's general terms and conditions of sale and delivery specify that an alarm system ***must be installed***.

We want to draw your attention to EU-directive No. 998 of 14/12-1993 concerning minimum requirements for domestic animals which specifies that an alarm system must be installed in any house which is mechanically ventilated. In addition to this, there must be a suitable emergency system.

Contents

1. INTRODUCTION	7
2. INSTALLATION	8
2.1 Introduction	8
2.1.1 Description of MultiStep® - Ventilation	8
2.1.2 Unpacking	8
2.2 Mechanical Installation	9
2.2.1 Opening of MC 36 A	9
2.2.2 Mounting of MC 36 A	9
2.2.3 Mounting of climate sensors	10
2.2.4 Electric Charts	11
2.2.4.1 Standard Wiring Diagram. Systems without Emergency Opening	11
2.2.4.2 Standard Wiring Diagram. System with ON/OFF Emergency Opening	11
2.2.4.3 Standard Wiring Diagram. Systems with Temperature Controlled Emergency Opening	12
2.2.4.4 Wiring Diagram. Winch Motors	13
2.2.4.5 Wiring Diagram. Fans, Heat, Cooling, 24-Hour Clock and Water Meter	14
2.2.4.6 Wiring Diagram. MultiStep®	15
2.3 Electrical Installation	16
2.3.1 Setting of Mains Voltage	16
2.3.1.1 Standard Wiring Diagram. Connection of Mains Voltage, Temperature Sensors and Alarm	17
2.3.1.2 Standard Wiring Diagram. Connection of Mains Voltage, Temperature Sensors, Alarm and Emergency Opening	18
2.3.1.3 Standard Wiring Diagram. Connection of Mains Voltage, Temperature Sensors, Alarm, MC 78T A Temperature Controlled Emergency Opening	19
2.3.2 Connection of Mains Voltage	20
2.3.3 Setting of the computer	20
2.3.4 Menu Survey Installation	22
2.3.5 Connection of the Individual Components	23
2.3.6 Fans	23
2.3.6.1 Wiring Diagram. Connection of Fans to Internal Speed Controller	23
2.3.6.2 Wiring Diagram. Connection of two Sequentially Controlled Fans to Internal Speed Controller. With more than one Fan an Auxiliary Contact is used	23
2.3.6.3 Wiring Diagram. Connection of Fan to Internal Speed Controller	23
2.3.6.4 Wiring Diagram. Connection of two Sequentially Controlled Fans to Internal Speed Controller	24
2.3.6.5 Wiring Diagram. Connection of MC 37 External Speed Controller	24
2.3.6.6 Wiring Diagram. Connection of MC 23U External Speed Controller	25
2.3.7 Humidity Sensor	25
2.3.7.1 Wiring Diagram. Connection of DOL 14 Humidity Sensor	25
2.3.8 Winch Motors	26
2.3.8.1 Wiring Diagram. Connection of 2 pcs. CL 75A 3D 24V R Decentralised Winch Motor for Air Inlet	26
2.3.8.2 Wiring Diagram. Connection of CL 75A 24V R Winch Motor for Air Inlet	27
2.3.8.3 Wiring Diagram. Connection of CL 75A 230V Winch Motor for Air Inlet	27
2.3.8.4 Wiring Diagram. Connection of CL 20 Winch Motors for Air Inlet	28
2.3.8.5 Wiring Diagram. Connection of CL 74A V Winch Motor for Air Outlet	29
2.3.8.6 Wiring Diagram. Connection of CL 74A MultiStep® Winch Motors for air Outlet	30
2.3.8.7 Wiring Diagram. Connection of MultiStep® Gable Fan for Air Outlet	31
2.3.9 Heat	31
2.3.9.1 Wiring Diagram. Connection of 0-10V Analog Heat 1 and 2	31
2.3.9.2 Wiring Diagram. Connection of Heat 1 (Relay)	32
2.3.9.3 Wiring Diagram. Connection of Heat 1 (Relay)	32
2.3.10 Special Connections	33
2.3.10.1 Wiring Diagram. Connection of Extra Ventilation with 230V Fan	33
2.3.10.2 Wiring Diagram. Connection of Extra Ventilation with 400V Fan	33
2.3.10.3 Wiring Diagram. Connection of Internal Cooling/Humidification/Soaking	34
2.3.10.4 Wiring Diagram. Connection of External Cooling	34
2.3.10.5 Wiring Diagram. Connection of 24-Hour Clock	34
2.3.10.6 Wiring Diagram. Connection of Belimo GM 24-SR Winch Motors for Air Outlet	35
2.3.10.7 Wiring Diagram. Connection of DOL 90 Water Meter	35
2.3.10.8 Wiring Diagram. Connection of Relay for Free Range	36
2.3.11 Emergency Ventilation	37
2.3.11.1 Wiring Diagram. Connection of CL 74A 24V Winch Motor for Emergency Air Intake	37
2.3.11.2 Wiring Diagram. Connection of CL 75A 24V Winch Motor for Emergency Air Intake	37
2.3.11.3 Wiring Diagram. Connection of Solenoid Valve 230V for Emergency Air Intake	37

2.4.2	Menu Survey, Adjustment of the System	38
2.4	Adjustment of the System	38
2.4.1	The Control Key and its Functions	38
2.4.3	Sub Menu "Adjustment of the System"	39
2.4.4	Setting of Date and Time	39
2.4.5	Setting of Production Form	40
2.4.6	Kind of Animal	40
2.4.7	Adjustment of MultiStep® Output	41
2.4.8	Fan Adjustment	42
2.4.9	Setting of 24-Hour Clock	42
2.4.10	Setting of Water Meter	42
2.4.11	Adjustment of Winch Potentiometer 1	43
2.4.12	Adjustment of Winch Potentiometer 1B	43
2.4.13	Adjustment of Winch Potentiometer 2	43
2.4.14	Adjustment of Winch Potentiometer 2B	43
2.4.15	Flap Opening Reduction	44
2.3.16	Temperature	44
2.4.17	Ventilation type of adjustment	44
2.4.18	Access Code	45
2.4.19	New Access Code	45
2.5	Testing	46
2.5.1	Check of House Temperature and Humidity Sensors	46
2.5.2	Check of Outdoor Temperature Sensor	46
2.5.3	Check of Alarm	46
2.5.4	Check of MC 78M A Emergency Opening Unit	47
2.5.5	Check of MC 78T A Temperature Controlled Emergency Opening	47
2.5.6	Manual Control	47
2.5.7	Control of Flap 1 and possibly Flap 1B (AIR INLET)	48
2.5.8	Check of Shutter 2 and Possibly 2B (Air Output)	49
2.5.9	Check of "Fan 1" and possibly „Fan 2“	49
2.5.10	Check of Emergency Switch AUT. / MAN.	50
2.5.11	Check of Fan (External Stepless Speed Controller, e.g. MC 23U or MC 37)	50
2.5.12	Check of Free Range	50
2.5.13	Check of MS-1 (MultiStep®-1)	51
2.5.14	Check of MS-2 (MultiStep®-2)	51
2.5.15	Check of MS-3 (MultiStep®-3)	51
2.5.16	Check of MS-4 (MultiStep®-4)	51
2.5.17	Check of MS-5 (MultiStep®-5)	51
2.5.18	Check of MS-6 (MultiStep®-6)	51
2.5.19	Check of Extra Vent. (Ventilation)	52
2.5.20	Check of Cooling Relay	52
2.5.21	Check of Humidification Relay	52
2.5.22	Check of Soaking Relay	52
2.5.23	Check of Heating-1	52
2.5.24	Check of Heating-2	52
2.5.25	Check of 24-Hour Clock	53
2.5.26	Termination of Test of Components	53
2.6	Spare Parts and Accessories	54
2.7	Technical Data	55
3.	SERVICE	56
3.1	Menu Survey/Service	56
3.1.1	Control Key Functions	57
3.1.2	Sub Menu "Service"	57
3.2	Automatic/Manual Control	58
3.3	Adjustment of Negative Pressure	58
3.3.1	Example, Adjustment of Negative Pressure	58
3.4	Adjustment of Stepless 1 Unit	60
3.4.1	Example	60
3.5	Adjustment of Stepless 2 unit	61

- 3.6 Winter Compensation 61
- 3.7 MultiStep® correction 61
- 3.8 Control Parameters 62
 - 3.8.1 Ventilation 62
 - 3.8.2 Cycle Timer 62
 - 3.8.4 Heating 63
 - 3.8.5 Analog Heating 1 63
 - 3.8.6 Analog Heating 2 63
 - 3.8.7 Comfort temperature 63
 - 3.8.8 Humidity Control 63
 - 3.8.9 Cooling 64
 - 3.8.10 Humidification 64
- 3.9 Memory 64
 - 3.9.1 Operation Log 64
 - 3.9.2 Present Set-Up 64
- 3.10 Servicing 65
 - 3.10.1 Maintenance 65
 - 3.10.2 Hints on Errors 65
 - 3.10.3 Temperature sensor control table 65

1. INTRODUCTION

This manual describes installation and setting up of the Euro Matic MC 36 A climate computer.

The MC 36 A climate computer has been developed to give complete climatic control of all types of livestock buildings where it can monitor and control the environment.

MC 36 A consists of a basic unit into which optional equipment can be installed, if required. The MC 36 A has been designed to accept an Euro Matic data module to allow the connection of a number of individual MC 36 A computers to one PC. Facility is included for the connection of external emergency opening using the MC 78 A.

Thanks to the high flexibility nature of the MC 36 A, the most productive climate control settings can be achieved at all times.

For your convenience, a copy of Section 2 of this user's guide is printed on a card. It should be inserted behind the opening panel of MC 36 A so it is always available.

BIG DUTCHMAN congratulate you on your choice of a
MC 36 A CLIMATE COMPUTER

2. INSTALLATION

2.1 Introduction

The installation section describes MultiStep® - ventilation, installation, setting and testing of MC 36 A climate computers.

2.1.1 Description of MultiStep® - Ventilation

BIG DUTCHMAN has developed MultiStep®, a method to control a number of outlet units stepwise, however with stepless exhaust. The computer controls one or two outlet unit(s) steplessly from 0-100%, while the rest of the outlet units are connected stepwise as required. Thus power savings of 40-70% are obtained.

Each outlet unit is equipped with a CL 74A swivel shutter motor to open and close the swivel shutter.

CL 74A V is used for the stepless outlet unit(s). The internal speed controller of MC 34H A adjusts the fan revolutions. The fan must always be single phase otherwise an external MC 23U must be used.

CL 74A ON/OFF is used for the outlet units in step 1 to 6. When the flaps open, the fans start via a built-in contact. These fans will then run in minimum. The fans could be single phase or three phase. If three phase is used, the CL 74A ON/OFF winch motors should be equipped with contactors controlled by a built-in contact. Furthermore, the system can work with air controlled flaps (gable fans).

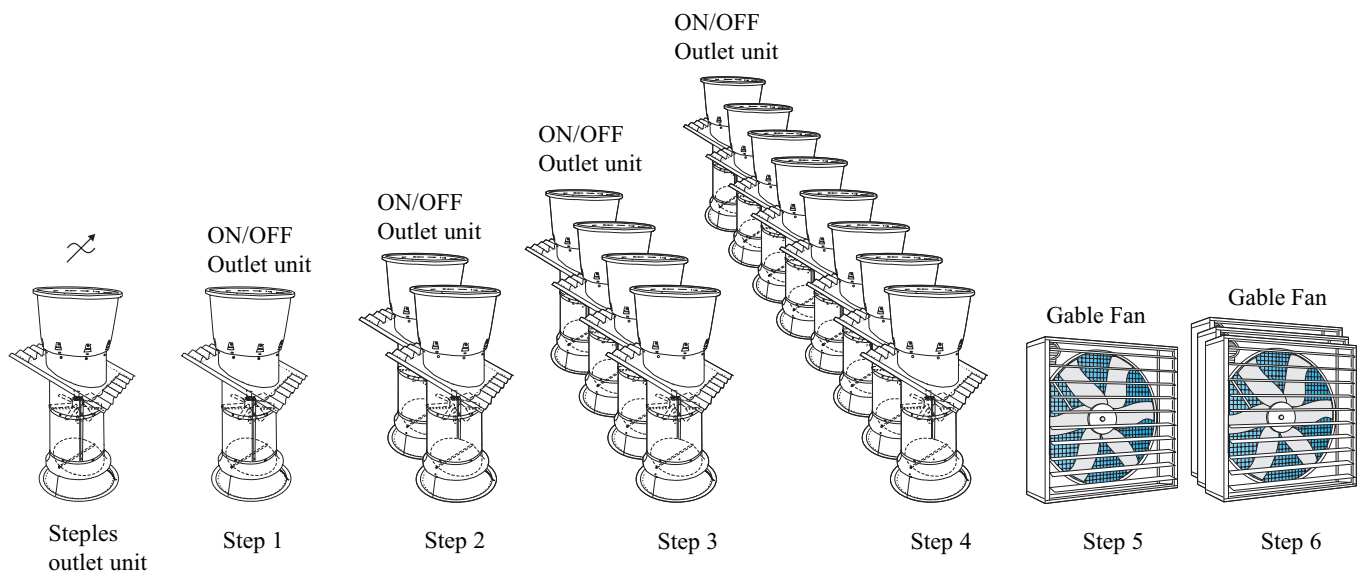

Figure 2.1.1-1 Example of MultiStep® exhaust

2.1.2 Unpacking

The MC 36 A climate computer lies at the bottom of the box. Up top you will find bags holding the manual and the folded user's guide, mounting screws/plugs, sensors and any accessory modules to be used together with this particular control unit. On the outside of the packaging there is a check list specifying the accessories enclosed.

2.2 Mechanical Installation

The mechanical installation section deals with installation of MC 36 A, installation of climate sensors and installation of accessory modules, if any.

2.2.1 Opening of MC 36 A

- 1) Open the lower cover plate by lifting at the bottom.
- 2) Remove the protective plate behind the cover plate. Loosen the screws but do not remove them.
- 3) Loosen the 2 screws in the control panel. Place the tilted panel on top of the computer during the electrical installation. Be careful, as the panel screws may fall off.
- 4) The lower cover plate can be removed during the electrical installation by removing one of the screws.
- 5) Having completed the electrical installation slide the folded User's Guide into the cover plate.

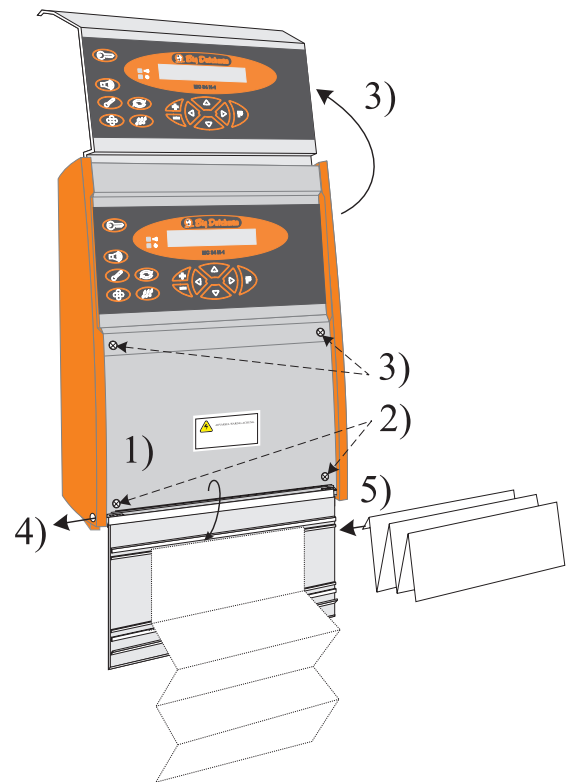

Figure 2.2.1-1 – Opening of MC 36 A

2.2.2 Mounting of MC 36 A

Hold the MC 36 A up against the wall making sure that the display is at the daily operator's eye level.

Mark the location of the two mounting screws through the rear holes in the MC 36 A.

Align the marks horizontally.

Bit dimension 8 mm.

Rubber washers are for sealing under the screw heads.

Remember to leave sufficient space around the MC 36 A to allow for AUT/MAN operation of the emergency switches and for the control panel to be placed on top of the cabinet.

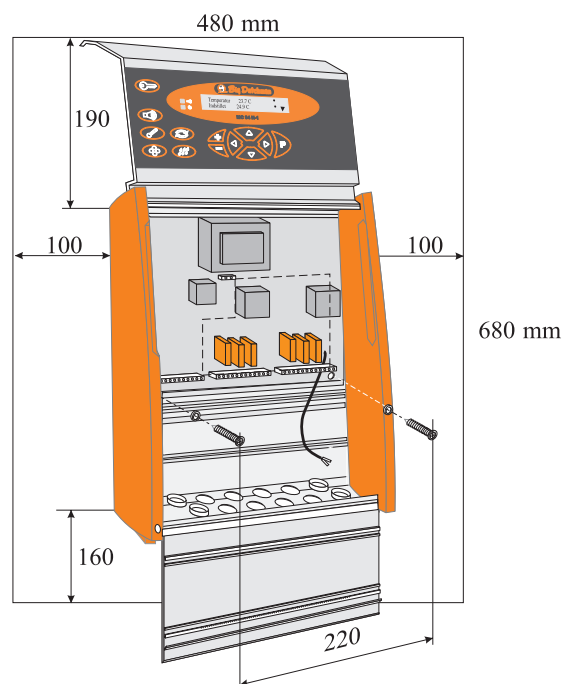

Figure 2.2.2-1 - Mounting of MC 36 A